

SECTION A-A
SCALE: 4:1

spec ref	-	dr	Hai-Ling Liu	2015/02/08	projection	MM	size	A2	scale	3:1
tolerance std	ASME Y14.5	eng	Hai-Ling Liu	2016/01/17			ecn no	ELX-DG-23038-1	rel level	Released
TOLERANCES UNLESS OTHERWISE SPECIFIED		chr	Terris Liu	2016/01/18			product family	HPCE		rel level
surface	✓	appr	Pai-Ming Zheng	2016/01/18			title	HPCE CTB VERT HEADER	dwg no	10133481
ASME Y14.5	linear	0.X	±0.5	0.XX	±0.25	0.XXX	±0.10	angular	0°	±2°
		www.fci.com	cat. no.	-		Product - Customer Drw	sheet 1 of 4	rev	B	

CONTACT TYPE	TOP LAYER DESCRIPTION	TABLE 1 (HPCE / SOLDER TAILS) PLATED THROUGH-HOLE REQUIREMENTS				
		DRILLED HOLE DIAMETER	COPPER THICKNESS	TIN-LEAD THICKNESS	TIN THICKNESS	FINISHED HOLE DIAMETER
POWER & SIGNAL	TIN-LEAD	1.10-1.16 (1.15 DRILL)	0.025 - 0.050	0.005 - 0.015	--	0.94 - 1.10
	IMMERSION TIN	1.10-1.16 (1.15 DRILL)	0.025 - 0.050	--	0.9 - 1.5um	0.94 - 1.10
	COPPER (SEE NOTE 8)	1.10-1.16 (1.15 DRILL)	0.025 - 0.050	--	--	0.94 - 1.10

CONTACT TYPE	TOP LAYER DESCRIPTION	TABLE 2 (HPCE / PRESS-FIT TAILS) PLATED THROUGH-HOLE REQUIREMENTS				
		DRILLED HOLE DIAMETER	COPPER THICKNESS	TIN-LEAD THICKNESS	TIN THICKNESS	FINISHED HOLE DIAMETER
POWER	TIN-LEAD	8.10-8.60 (0.85 DRILL)	0.025 - 0.050	0.005 - 0.015	--	0.65 - 0.80
	IMMERSION TIN	8.10-8.60 (0.85 DRILL)	0.025 - 0.050	--	0.9 - 1.5um	0.70 - 0.80
	COPPER (SEE NOTE 8)	8.10-8.60 (0.85 DRILL)	0.025 - 0.050	--	--	0.70 - 0.80

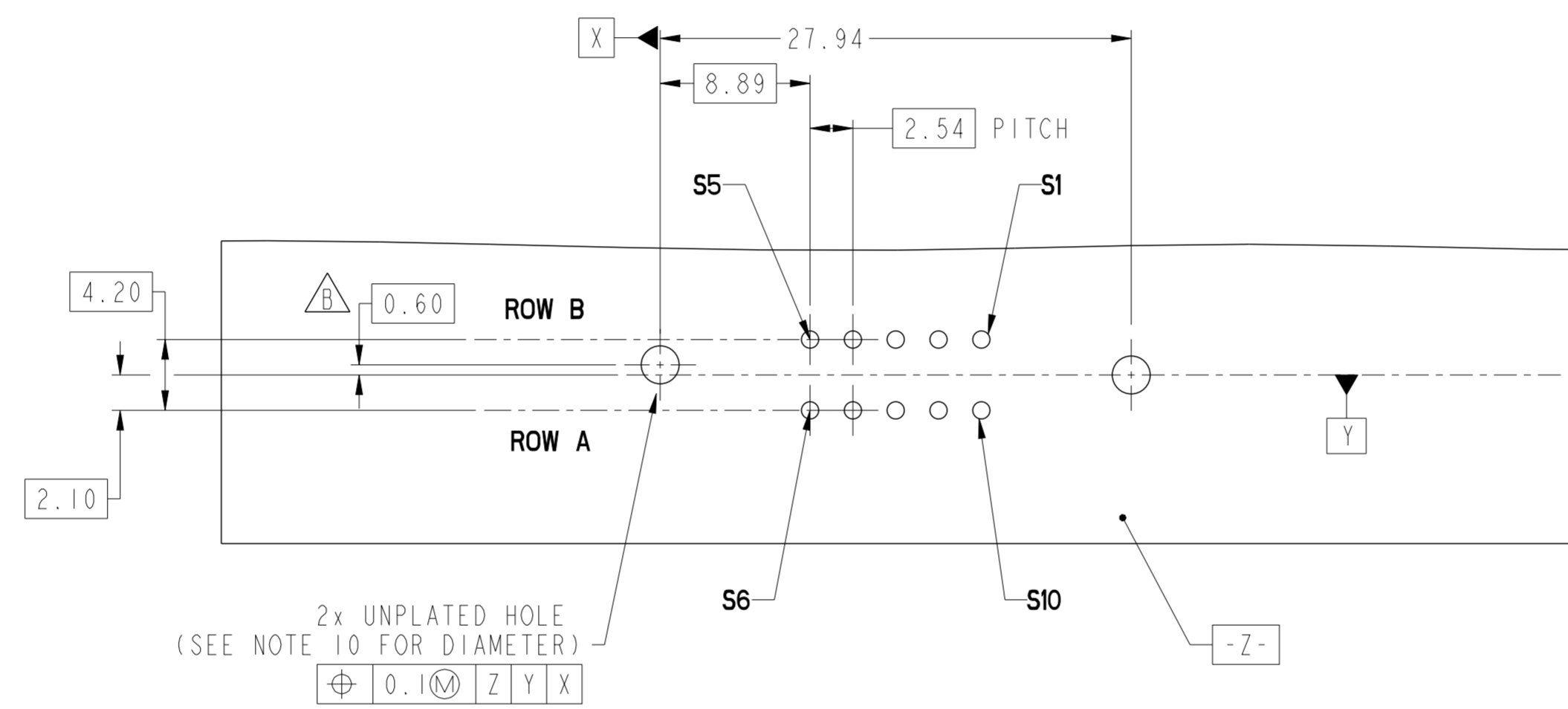

RECOMMENDED PCB LAYOUT
VIEW FROM CONNECTOR SIDE

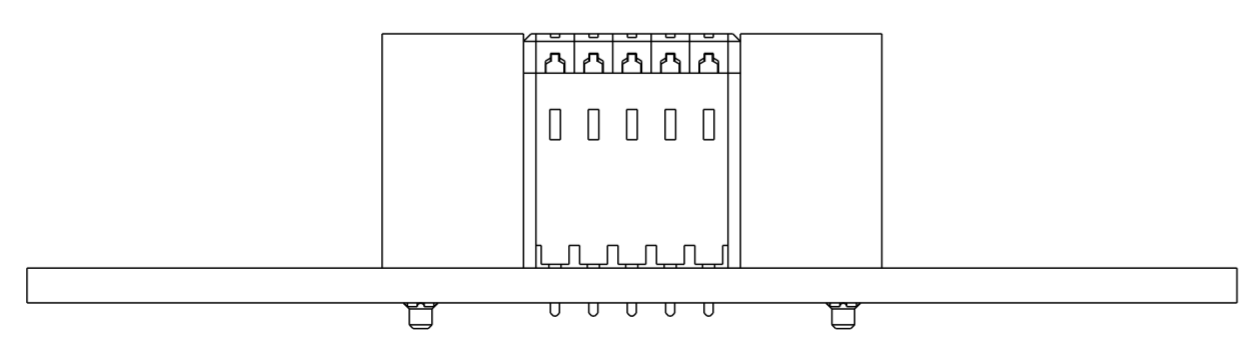

SCALE 2:1

dr	Hai-Ling Liu	2015/02/08	projection	MM	size	A2	scale	3:1	
eng	Hai-Ling Liu	2016/01/17			ecn no.	ELX-DG-23038-1	rel level	Released	
chr	Terris Liu	2016/01/18			product family	HPCE			
appr	Pei-Ming Zheng	2016/01/18			title	HPCE CTB VERT HEADER	dwg no.	10133481	
www.fci.com			cat. no.		Product - Customer Drw		sheet 2 of 4	rev	B

PRODUCT PART NUMBER

10133481-□□□□□□ LF

BASE PART NUMBER

TAIL TYPE
A: STB
B: PF

CONTACT AREA PLATING
UNDERPLATED 50u"(1.27um) MIN. NICKEL
1: 100u"(2.5um) MIN. Ag
2: 30u"(0.760um) MIN. GXT

FIRST MATE LAST BREAK PIN POSITION
000: ALL PINS ARE LONG PINS SEE TABLE

DIM "A", TAIL LENGTH FOR STB TAIL
1: 2.60±0.25mm (PCB THK 1.57±0.13mm)
2: 3.25±0.25mm (PCB THK 2.36±0.13mm)
DIM "A", TAIL LENGTH FOR PF TAIL
2: 3.04±0.25mm((PCB THK 1.57±0.13mm)

NOTES:

1. CONNECTOR MATERIALS:
HOUSING: HIGH TEMPERATURE THERMAL PLASTIC, BLACK UL 94V-0 COMPLIANT
CONTACTS: HIGH PERFORMANCE COPPER ALLOY.
2. CONTACT FINISH REF. GS-12-1031 SECTION 5.2
3. PRODUCT SPECIFICATION: GS-12-1031
4. APPLICATION SPECIFICATION: GS-20-0369
5. PRODUCT MARKING ON HOUSING IN AREA SHOWN MEET FCI SPECIFICATION GS-24-007.
6. PACKAGING MEETS FCI SPECIFICATION GS-14-2272.
7. HOUSING COMPONENT WILL WITHSTAND EXPOSURE TO 260°C PEAK TEMPERATURE FOR 60 SECONDS IN A CONVECTION, INFRA-RED, OR VAPOR PHASE REFLOW OVEN.
8. COPPER PLATING THICKNESS IN CENTER OF VIA-HOLE CAN BE NO MORE THAN 0.003 LESS THAN OTHER AREAS.
9. ALL HOLE SIZES ARE FINISHED HOLE SIZES.
10. MOUNTING HOLES ARE UNPLATED
Ø2.25±0.05 FOR SOLDER TAILS
Ø2.40±0.1 FOR PRESS-FIT TAILS

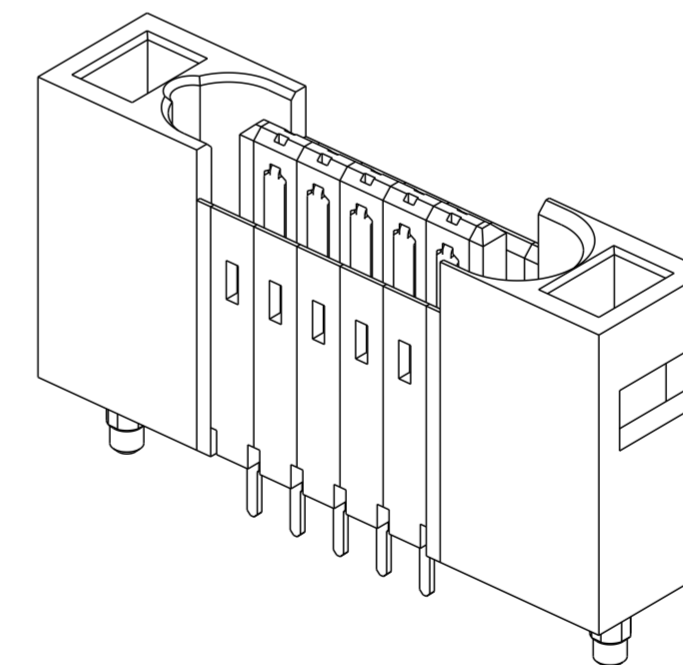

dr	Hai-Ling Liu	2015/02/08		MM	size	A2	scale	3:1	
eng	Hai-Ling Liu	2016/01/17			ecn no	ELX-DG-23038-1			
chr	Terris Liu	2016/01/18			rel level	Released			
appr	Pei-Ming Zheng	2016/01/18			product family	HPCE			
		title	HPCE CTB VERT HEADER		dwg no	10133481		rev	B
www.fci.com		cat. no.	-		Product - Customer Drw		sheet 3 of 4		

000	END MODULE	SIGNAL CONTACT					END MODULE	
			5	4	3	2		1
		ROW A	S3/S9	S3/S9	S3/S9	S3/S9		S3/S9
		ROW B	S3/S9	S3/S9	S3/S9	S3/S9		S3/S9
S3 FOR STB TAIL, S9 FOR PF TAIL								

	ROW#	S#	DIM "B"±0.25	DIM "A"±0.25
SIGNAL CONTACT	ROW A	S1	8.73	3.25
		S2	7.46	3.25
		S3	8.73	2.60
		S4	7.46	2.60
		S9	8.73	3.04
		S10	7.46	3.04
	ROW B	S1	8.73	3.25
		S2	7.46	3.25
		S3	8.73	2.60
		S4	7.46	2.60
	S9	8.73	3.04	
	S10	7.46	3.04	

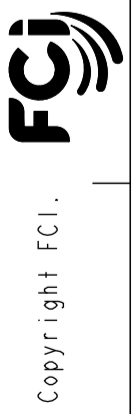

dr	Hai-Ling Liu	2015/02/08	projection	MM	size	A2	scale	3:1	
eng	Hai-Ling Liu	2016/01/17			ecn no	ELX-DG-23038-1			
chr	Terris Liu	2016/01/18			product family	HPCE	rel level	Released	
appr	Pai-Ming Zheng	2016/01/18			title	HPCE CTB VERT HEADER		rev	B
www.fci.com		cat. no.			dwg no	10133481		sheet 4 of 4	



Компания «ЭлектроПласт» предлагает заключение долгосрочных отношений при поставках импортных электронных компонентов на взаимовыгодных условиях!

Наши преимущества:

- Оперативные поставки широкого спектра электронных компонентов отечественного и импортного производства напрямую от производителей и с крупнейших мировых складов;
- Поставка более 17-ти миллионов наименований электронных компонентов;
- Поставка сложных, дефицитных, либо снятых с производства позиций;
- Оперативные сроки поставки под заказ (от 5 рабочих дней);
- Экспресс доставка в любую точку России;
- Техническая поддержка проекта, помощь в подборе аналогов, поставка прототипов;
- Система менеджмента качества сертифицирована по Международному стандарту ISO 9001;
- Лицензия ФСБ на осуществление работ с использованием сведений, составляющих государственную тайну;
- Поставка специализированных компонентов (Xilinx, Altera, Analog Devices, Intersil, Interpoint, Microsemi, Aeroflex, Peregrine, Syfer, Eurofarad, Texas Instrument, Miteq, Cobham, E2V, MA-COM, Hittite, Mini-Circuits, General Dynamics и др.);

Помимо этого, одним из направлений компании «ЭлектроПласт» является направление «Источники питания». Мы предлагаем Вам помощь Конструкторского отдела:

- Подбор оптимального решения, техническое обоснование при выборе компонента;
- Подбор аналогов;
- Консультации по применению компонента;
- Поставка образцов и прототипов;
- Техническая поддержка проекта;
- Защита от снятия компонента с производства.



Как с нами связаться

Телефон: 8 (812) 309 58 32 (многоканальный)

Факс: 8 (812) 320-02-42

Электронная почта: org@eplast1.ru

Адрес: 198099, г. Санкт-Петербург, ул. Калинина, дом 2, корпус 4, литера А.