

110V LED Controller with Spread Spectrum Frequency Modulation

DESCRIPTION

Demonstration Circuit 1827A features a 110V LED controller with spread spectrum frequency modulation - the [LT[®]3795](#). Unlike most boosts, the circuit disconnects the output to protect against shorts or other fault conditions when the input voltage exceeds the output. The input voltage range for normal operation is from 8V to 60V. OVLO becomes active for inputs above 63V and the maximum input voltage is 110V. The LED current is 400mA and the switching frequency is 250kHz. The efficiency is 92% when the input is 12V and the LED voltage is at 87V which is the maximum LED voltage.

Spread spectrum switching is available to simplify conducted emissions compliance. There is a 47nF capacitor from the RAMP pin to ground to set the rate at which frequency modulation occurs, but resistor R20 shorting the RAMP pin capacitor must be removed to activate spread spectrum.

OVLO and EN/UVLO are both set using resistor dividers. EN/UVLO is set so the circuit will UVLO when the input voltage falls below 6V and will turn on when the input voltage rises above 7.5V.

Current sense resistors program LED current and input regulation current and also determine the monitoring voltages that indicate output and input current. The LED current is set by RS2. ISMON provides a 2.5V/1A voltage that is used to monitor the LED current. Input current regulation occurs at 4A and is set by RS3. IVINCOMP provides a 300mV/1A voltage that is used to monitor the input current. Capacitor C11 on the IVINCOMP pin provides compensation for the input current regulation loop. CTRL1 and CTRL2 are analog dimming inputs that allow external voltages to reduce the LED current from the programmed maximum. CTRL1 and CTRL2 are pulled up to the V_{REF} pin by 100k resistors. SHORTLED and OPENLED are open-collector status flag outputs that are pulled up to the INTV_{CC} pin voltage.

The circuit requires application of an external voltage to the PWM terminal for operation. The external voltage can be a DC level or an appropriate pwm dimming signal. A

common frequency for PWM dimming is 100Hz. The high-side PMOS FET that is used for pwm dimming also disconnects the output to protect against shorts.

The soft-start pin (SS) is configured so the circuit will hiccup when a fault occurs and will not latch off. The demo circuit also supports the adjustment capability of the LT3795 for switching frequency and feedback loop compensation.

The FB pin is programmed using a resistor divider to limit the output voltage in case there is no LED string on the output. When an open LED transient occurs either at start up or because the LED string opens, the peak output voltage may overshoot to 100V but FB will regulate the settled output voltage to 95V.

The demo circuit uses ceramic input and output capacitors. An aluminum electrolytic capacitor can be easily added to the input if it is necessary for stability during conducted emissions testing. The 120V switching MOSFET allows 110V on the input. FB programming inhibits switching at high output voltages so the 100V rating of the rectifier is not exceeded.

The demo circuit is designed to be easily reconfigured to buck mode, buck-boost mode and SEPIC topologies. There are example schematics in the data sheet. Consult the factory for assistance.

Maximum input and output voltages of 110V, spread spectrum switching, fault protection and full monitoring make the LT3795 attractive for high voltage and high power LED circuits, battery chargers and voltage regulators that require an accurate current limit. DC1827A uses the LT3795EFE which is packaged in a thermally enhanced 28-lead TSSOP. The LT3795 data sheet must be read in conjunction with this demo manual to properly use or modify DC1827A.

Design files for this circuit board are available at <http://www.linear.com/demo/DC1827A>

LT, LT, LTC, LTM, Linear Technology and the Linear logo are registered trademarks of Linear Technology Corporation. All other trademarks are the property of their respective owners.

PERFORMANCE SUMMARY Specifications are at T_A = 25°C

PARAMETER	CONDITIONS	MIN	TYP	MAX	UNITS
Minimum Input, V _{PVIN}	V _{LED} = 87V, I _{LED} ≤ 400mA			8	V
Maximum Input – Switching, V _{PVIN}	V _{LED} = 87V, I _{LED} ≤ 400mA	60			V
Maximum Input – Not Switching, V _{PVIN}	V _{OVLO} ≥ 1.25V	110			V
Maximum LED Voltage, V _{LED}		87			V
LED Current, I _{LED}	RS2 = 0.62Ω		400		mA
Input EN Voltage, V _{PVIN(EN)}	V _{PVIN} Rising R1 = 499k, R2 = 115k, R3 = 12.4k		7.5		V
Input UVLO Voltage, V _{PVIN(UVLO)}	V _{PVIN} Falling R1 = 499k, R2 = 115k, R3 = 12.4k		6		V
Input OVLO Turn-Off Voltage, V _{PVIN(OVLO_TURN-OFF)}	V _{PVIN} Rising R1 = 499k, R2 = 115k, R3 = 12.4k		63.1		V
Input OVLO Turn-On Voltage, V _{PVIN(OVLO_TURN-ON)}	V _{PVIN} Falling R1 = 499k, R2 = 115k, R3 = 12.4k		62.1		V
Efficiency	V _{PVIN} = 12V, V _{LED} = 87V, I _{LED} = 400mA V _{PVIN} = 24V, V _{LED} = 87V, I _{LED} = 400mA V _{PVIN} = 48V, V _{LED} = 87V, I _{LED} = 400mA		92 91 92		% % %
Switching Frequency	R5 = 31.6k		250		kHz
Input Current Limit	RS3 = 0.015Ω		4		A

QUICK START PROCEDURE

It is easy to set up DC1827A to evaluate the performance of the LT3795. Follow the procedure below:

NOTE: PWM must be pulled high to work. If PWM is not used, connect the PWM terminal to a 2V to 5V DC source or connect the PWM pin to V_{REF} on the PCB using R18.

1. Connect a string of LEDs with a forward voltage of 87V or less, but greater than the PV_{IN} voltage, to the LED+ and GND terminals on the PCB as shown in Figure 1.
2. Connect the EN/UVLO terminal to GND.
3. With the power off, connect the input power supply to the PVIN and GND terminals within the voltage range specified on the PCB. Make sure that the input power supply voltage does not exceed the forward voltage of the LED string. OVLO becomes active to inhibit switching for an input voltage greater than 63V.
4. Connect an input to the PWM terminal. If PWM is not used, connect PWM to a 2V to 5V DC source or to V_{REF} on the PCB using resistor R18. PWM must be pulled high to work. For PWM dimming, connect a 100Hz or higher PWM signal to the PWM terminal.
5. Turn the PVIN power supply on.
6. Release the EN/UVLO to GND connection.
7. Observe the LED string running at the programmed LED current; or, observe the reduction of brightness in the LED string with PWM dimming.

QUICK START PROCEDURE

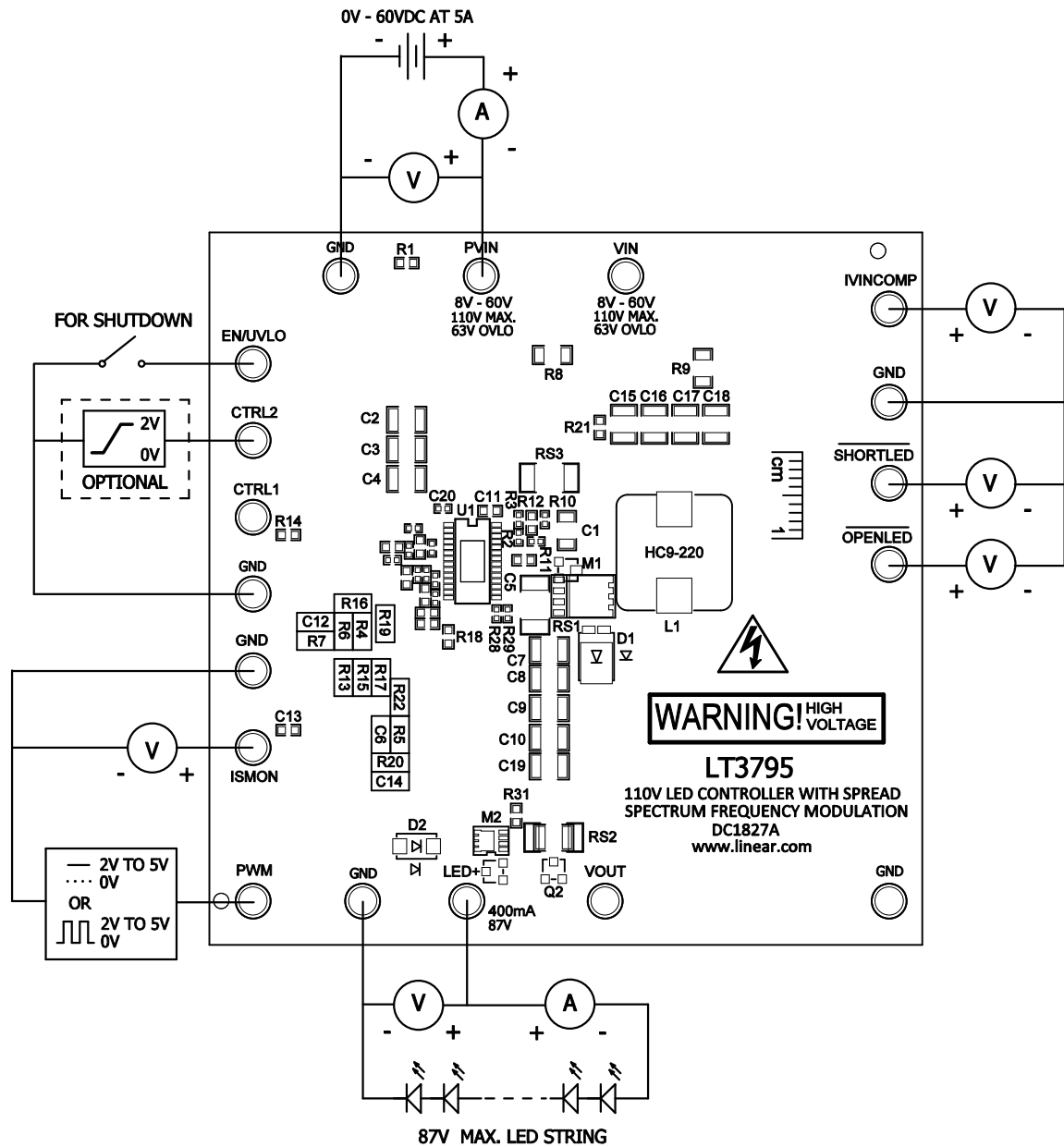
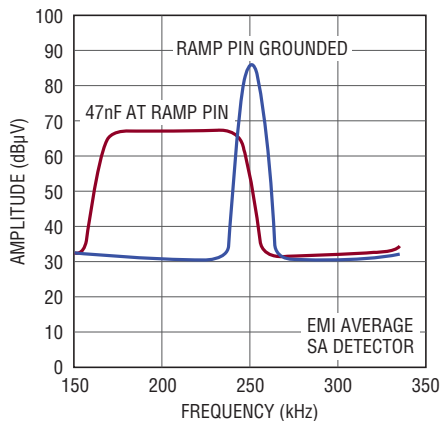

Figure 1. Proper Measurement Equipment Setup for DC1827A

QUICK START PROCEDURE



DC1827A F02

Figure 2. Conducted Emissions without Spread Spectrum (RAMP Pin Grounded) and the Improvement that Occurs with Spread Spectrum Switching (47nF at RAMP Pin)

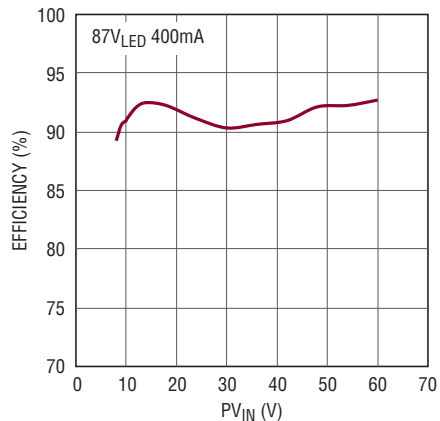

DC1827A F03

Figure 3. DC1827A Efficiency with 87V_{LED} at 400mA

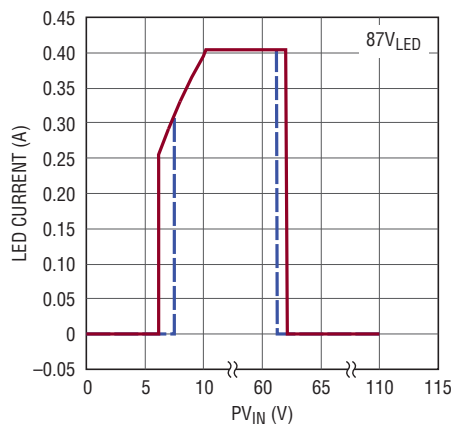

DC1827A F04

Figure 4. The LED String is 87V. This Output Current vs Input Voltage Graph Shows the Wide Input Voltage Range and the Input Voltages at Which UVLO, Turn-On and OVLO Occur. Input Current Limit Occurs When V_{IN} Is 10V or Less.

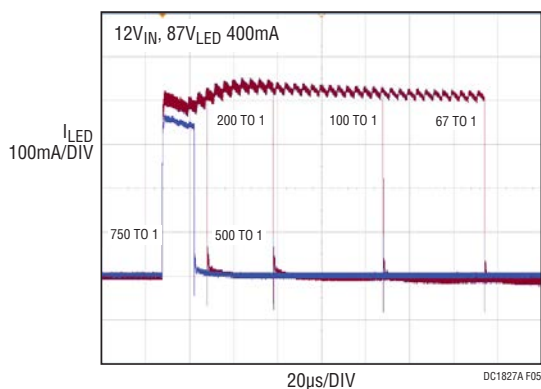

DC1827A F05

Figure 5. LED Current During PWM Dimming at 100Hz

PARTS LIST

ITEM	QTY	REFERENCE	PART DESCRIPTION	MANUFACTURER/PART NUMBER
Required Circuit Components				
1	1	C1	Cap., X7R 1 μ F 100V 20% 1206	AVX 12061C105MAT2A
2	7	C2, C3, C4, C7, C8, C9	Cap., X7R 2.2 μ F 100V 10% 1210	Murata GRM32ER72A225KA35L
		C10		
3	1	C5	Cap., X5R 4.7 μ F 10V 10% 0603	AVX 0603ZD475KAT2A
4	1	C6	Cap., X7R 0.1 μ F 25V 10% 0603	AVX 06033C104KAT2A
5	1	C12	Cap., X7R 0.01 μ F 10V 10% 0603	AVX 0603ZC103KAT1A
6	1	D1	Schottky Diode 5A POWERDI5	Diodes Inc. PDS5100-13
7	1	L1	Inductor, 22 μ H HC9-SERIES	Cooper Bussmann HC9-220-R
8	1	M1	Mosfet N-Channel, 120V/44A Super SO8	Infineon BSC190N12NS3G
9	1	M2	Mosfet P-Channel, 150V PowerPak 1212-8	Vishay Siliconix Si7115DN-T1-E3
10	1	RS1	Res., LRC 0.015 0.5W 1% 2010	IRC LRC-LR2010LF-01-R015-F
11	1	RS2	Res., LRC 0.620 0.5W 1% 2010	SEI CSRN2010FKR620
12	1	R4	Res., Chip 1.00M 0.06W 1% 0603	NIC NRC06F1004TRF
13	1	R5	Res., Chip 31.6k 0.06W 1% 0402	Vishay CRCW040231K6FKED
14	1	R6	Res., Chip 13.3k 0.06W 1% 0402	Vishay CRCW040213K3FKED
15	1	R7	Res., Chip 10k 0.06W 5% 0402	Vishay CRCW040210K0JNED
16	1	U1	I.C., LED Driver TSSOP28-FE/EB	Linear Tech. Corp. LT3795EFE
Optional Demo Circuit Components				
1	1	C13	Cap., X5R 0.1 μ F 25V 10% 0603	AVX 06033C104KAT2A
2	1	C11	Cap., X7R 0.01 μ F 10V 10% 0603	AVX 0603ZC103KAT1A
3	1	C14	Cap., X7R 0.047 μ F 16V 10% 0603	AVX 0603YC473KAT1A
4	0	C15, C16, C17, C18, C19	Cap., 1210	
5	0	C20	Cap., 0402	
6	0	C21	Cap., 12.5mm Dia.	
7	1	D2	Ultra Fast Rect., 150V/1A SMA	Fairchild Semi. ES1C
8	0	M3	Mosfet N-Channel SOT23	
9	0	Q1,Q2	Trans., PNP SOT23	Zetex FMMT593
10	1	RS3	Res., LRC 0.015 0.5W 1% 2010	IRC LRC-LR2010LF-01-R015-F
11	1	R1	Res., Chip 499k 0.06W 1% 0603	Vishay CRCW0603499KFKEA
12	1	R2	Res., Chip 115k 0.06W 1% 0402	Vishay CRCW0402115KFKED
13	1	R3	Res., Chip 12.4k 0.06W 1% 0402	Vishay CRCW040212K4FKED
14	1	R8	Res./Jumper, Chip 0 Ω 1/4W 1A 1206	Vishay CRCW12060000Z0EA
15	0	R9	Res., 1206	
16	0	R10, R15, R19, R22	Res., 0402	
17	1	R11	Res./Jumper, Chip 0 Ω 1/16W 1A 0402	Vishay CRCW04020000Z0ED
18	0	R12, R13, R14, R18, R21, R23, R24, R25, R26, R27, R30, R31, R32	Res., 0603	
19	4	R16, R17, R28, R29	Res., Chip 100k 0.06W 5% 0402	Vishay CRCW0402100KJNED
20	1	R20	Res./Jumper, Chip 0 Ω 1/16W 1A 0603	Vishay CRCW06030000Z0EA

DEMO MANUAL DC1827A

PARTS LIST

ITEM	QTY	REFERENCE	PART DESCRIPTION	MANUFACTURER/PART NUMBER
Hardware				
1	18	E1, E2, E3, E4, E5, E6, E7, E8, E9, E10, E11, E12, E13, E14, E15, E16, E17, E18	Turret, Testpoint	Mill Max 2501-2-00-80-00-00-07-0

SCHEMATIC DIAGRAM

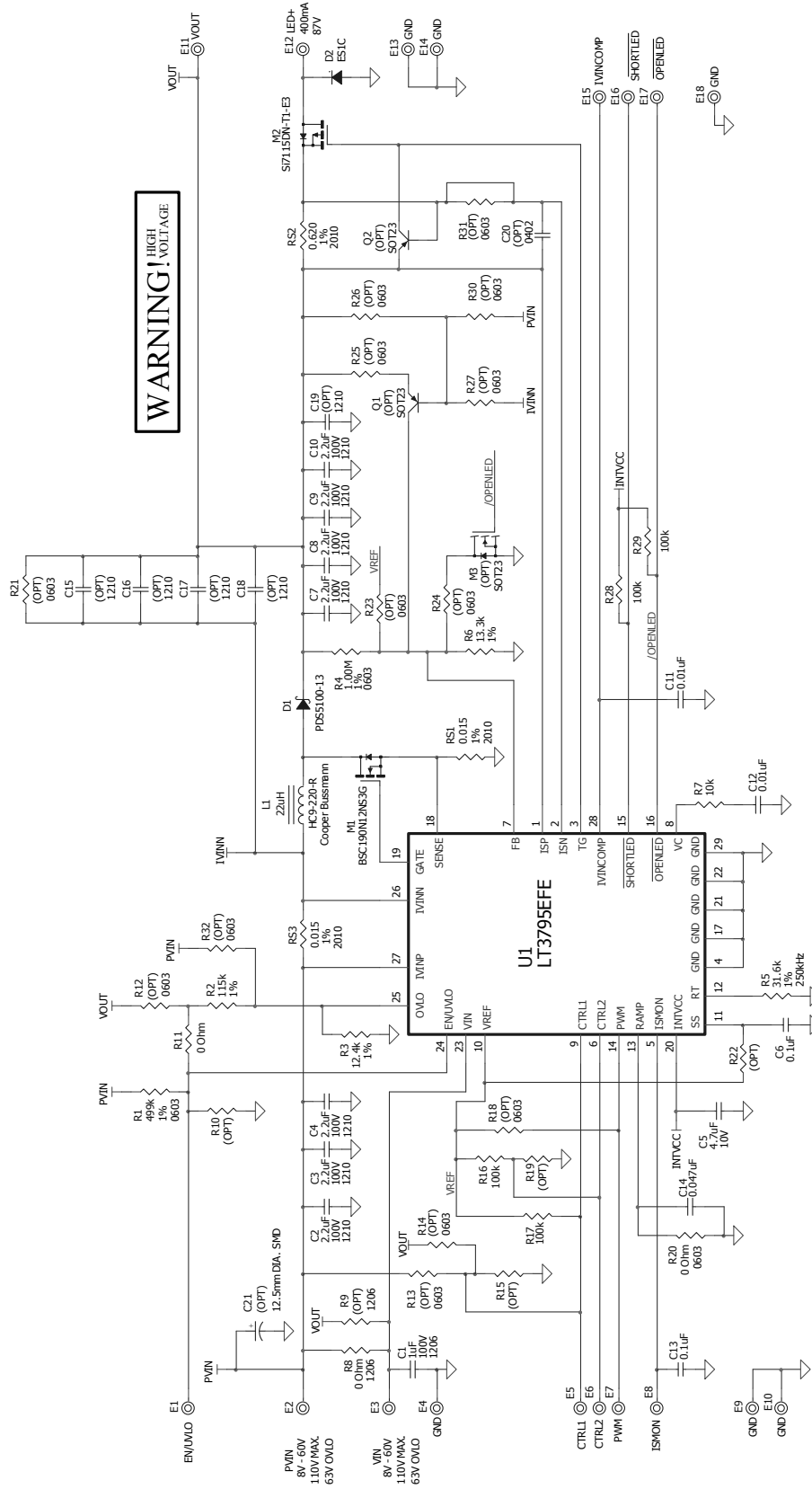

DEMO MANUAL DC1827A

DEMONSTRATION BOARD IMPORTANT NOTICE

Linear Technology Corporation (LTC) provides the enclosed product(s) under the following **AS IS** conditions:

This demonstration board (DEMO BOARD) kit being sold or provided by Linear Technology is intended for use for **ENGINEERING DEVELOPMENT OR EVALUATION PURPOSES ONLY** and is not provided by LTC for commercial use. As such, the DEMO BOARD herein may not be complete in terms of required design-, marketing-, and/or manufacturing-related protective considerations, including but not limited to product safety measures typically found in finished commercial goods. As a prototype, this product does not fall within the scope of the European Union directive on electromagnetic compatibility and therefore may or may not meet the technical requirements of the directive, or other regulations.

If this evaluation kit does not meet the specifications recited in the DEMO BOARD manual the kit may be returned within 30 days from the date of delivery for a full refund. **THE FOREGOING WARRANTY IS THE EXCLUSIVE WARRANTY MADE BY THE SELLER TO BUYER AND IS IN LIEU OF ALL OTHER WARRANTIES, EXPRESSED, IMPLIED, OR STATUTORY, INCLUDING ANY WARRANTY OF MERCHANTABILITY OR FITNESS FOR ANY PARTICULAR PURPOSE. EXCEPT TO THE EXTENT OF THIS INDEMNITY, NEITHER PARTY SHALL BE LIABLE TO THE OTHER FOR ANY INDIRECT, SPECIAL, INCIDENTAL, OR CONSEQUENTIAL DAMAGES.**

The user assumes all responsibility and liability for proper and safe handling of the goods. Further, the user releases LTC from all claims arising from the handling or use of the goods. Due to the open construction of the product, it is the user's responsibility to take any and all appropriate precautions with regard to electrostatic discharge. Also be aware that the products herein may not be regulatory compliant or agency certified (FCC, UL, CE, etc.).

No License is granted under any patent right or other intellectual property whatsoever. **LTC assumes no liability for applications assistance, customer product design, software performance, or infringement of patents or any other intellectual property rights of any kind.**

LTC currently services a variety of customers for products around the world, and therefore this transaction **is not exclusive**.

Please read the DEMO BOARD manual prior to handling the product. Persons handling this product must have electronics training and observe good laboratory practice standards. **Common sense is encouraged.**

This notice contains important safety information about temperatures and voltages. For further safety concerns, please contact a LTC application engineer.

Mailing Address:

Linear Technology
1630 McCarthy Blvd.
Milpitas, CA 95035

Copyright © 2004, Linear Technology Corporation



Компания «ЭлектроПласт» предлагает заключение долгосрочных отношений при поставках импортных электронных компонентов на взаимовыгодных условиях!

Наши преимущества:

- Оперативные поставки широкого спектра электронных компонентов отечественного и импортного производства напрямую от производителей и с крупнейших мировых складов;
- Поставка более 17-ти миллионов наименований электронных компонентов;
- Поставка сложных, дефицитных, либо снятых с производства позиций;
- Оперативные сроки поставки под заказ (от 5 рабочих дней);
- Экспресс доставка в любую точку России;
- Техническая поддержка проекта, помощь в подборе аналогов, поставка прототипов;
- Система менеджмента качества сертифицирована по Международному стандарту ISO 9001;
- Лицензия ФСБ на осуществление работ с использованием сведений, составляющих государственную тайну;
- Поставка специализированных компонентов (Xilinx, Altera, Analog Devices, Intersil, Interpoint, Microsemi, Aeroflex, Peregrine, Syfer, Eurofarad, Texas Instrument, Miteq, Cobham, E2V, MA-COM, Hittite, Mini-Circuits, General Dynamics и др.);

Помимо этого, одним из направлений компании «ЭлектроПласт» является направление «Источники питания». Мы предлагаем Вам помощь Конструкторского отдела:

- Подбор оптимального решения, техническое обоснование при выборе компонента;
- Подбор аналогов;
- Консультации по применению компонента;
- Поставка образцов и прототипов;
- Техническая поддержка проекта;
- Защита от снятия компонента с производства.



Как с нами связаться

Телефон: 8 (812) 309 58 32 (многоканальный)

Факс: 8 (812) 320-02-42

Электронная почта: org@eplast1.ru

Адрес: 198099, г. Санкт-Петербург, ул. Калинина, дом 2, корпус 4, литера А.