

FEATURES

- Ranges from 1 to 30 "H₂O and 2.5 to 75 mbar differential or gage
- Precision temperature compensated
- Calibrated offset and span
- Extremely low position sensitivity
- Excellent long term stability
- Ratiometric output or internal supply regulation

SERVICE

Non-corrosive, non-ionic working fluids such as clean dry air, dry gases and the like.

The media wetted materials are:

- silicon diaphragm
- glass filled nylon
- RTV
- ceramic (Al₂O₃)



EQUIVALENT CIRCUIT



SPECIFICATIONS

Maximum ratings (for all devices)

Supply voltage V_s	4.9 to 5.1 V (DC...C4)
	7 to 30 V (DC...R4, DC...R5)
Lead temperature (soldering 5 sec.)	315 °C
Maximum load current	
Source	2 mA
Sink	20 μ A

Environmental specifications (for all devices)

Temperature range	
Compensated	0 to 50°C
Operating	-25 to +85°C
Storage	-40 to +125°C
Humidity limits (non-condensing)	0 to 95 %RH

CAUTION Applications requiring supply voltages greater than 20 V on power-up must have a 10 Ohm resistor installed between pin 1 of the sensor and the positiv (+) lead of the power supply.

If the sensor is subjected to a supply voltage of >20 V without ramp up, a current spike may occur causing the operational amplifier and/or the ASIC to fail.

Do not operate above 30 V max. Due to internal component ratings, the maximum safe operating voltage specification is 30 V.

PRESSURE SENSOR CHARACTERISTICS

Part no.	Pressure ranges	Proof pressure ¹	Burst pressure ²
DC001N...	1 "H ₂ O	100 "H ₂ O	200 "H ₂ O
DC002N...	2 "H ₂ O	100 "H ₂ O	200 "H ₂ O
DC2R5N...	2.5 "H ₂ O	100 "H ₂ O	200 "H ₂ O
DC005N...	5 "H ₂ O	150 "H ₂ O	300 "H ₂ O
DC010N...	10 "H ₂ O	150 "H ₂ O	300 "H ₂ O
DC020N...	20 "H ₂ O	300 "H ₂ O	450 "H ₂ O
DC030N...	30 "H ₂ O	450 "H ₂ O	600 "H ₂ O
DC2R5B...	2.5 mbar	250 mbar	500 mbar
DC005B...	5 mbar	250 mbar	500 mbar
DC010B...	10 mbar	375 mbar	750 mbar
DC025B...	25 mbar	375 mbar	750 mbar
DC050B...	50 mbar	750 mbar	1125 mbar
DC075B...	75 mbar	1125 mbar	1500 mbar

Notes

- ¹ Proof pressure is the maximum pressure which may be applied without causing durable shifts of the electrical parameters of the sensing element.
- ² Burst pressure is the maximum pressure which may be applied without causing damage to the sensing element or leaks from the housing.

DC...C4 PERFORMANCE CHARACTERISTICS

0.25...4.25 V ratiometric output version ($V_S = 5.0$ V, $T_A = 25^\circ\text{C}$, pressure applied to port 2)

Characteristics		Min.	Typ.	Max.	Unit
Zero pressure offset	DC...G...		0.25		V
	DC...D...		2.25		
Full scale span ³	DC...G...		4.0		
	DC...D...		±2.0		
Total accuracy (0 - 50 °C) ⁴	DC001N... DC2R5B...		±2.0	±3.0	%FSO
	DC002N..., DC2R5N... DC005B...		±1.5	±2.5	
	all others		±1.0	±2.0	
Offset position sensitivity (±1 g)	DC001N... to DC2R5N... DC2R5B..., DC005B...			±10	mV
	DC005N...			±5	
	DC010B...				
	all others			±1	

DC...R4 PERFORMANCE CHARACTERISTICS

0.25...4.25 V regulated output version ($V_S = 15.0$ V, $T_A = 25^\circ\text{C}$, pressure applied to port 2)

Characteristics		Min.	Typ.	Max.	Unit
Zero pressure offset	DC...G...		0.25		V
	DC...D...		2.25		
Full scale span ³	DC...G...		4.0		
	DC...D...		±2.0		
Total accuracy (0 - 50 °C) ⁴	DC001N... DC2R5B...		±2.0	±3.0	%FSO
	DC002N..., DC2R5N... DC005B...		±1.5	±2.5	
	all others		±1.0	±2.0	
Offset position sensitivity (±1 g)	DC001N... to DC2R5N... DC2R5B..., DC005B...			±10	mV
	DC005N...			±5	
	DC010B...				
	all others			±1	

Notes:

³ Full scale span is the algebraic difference between the output voltage at full-scale pressure and the output at zero pressure.

⁴ Total accuracy includes non-linearity, hysteresis, repeatability, zero offset and span error, thermal effect on zero offset and span. Non-linearity refers to the **Best Straight Line** fit measured for offset pressure, full-scale pressure and ½ full-scale pressure.

DC...R5 PERFORMANCE CHARACTERISTICS

1...6 V regulated output version ($V_s = 15.0\text{ V}$, $T_A = 25^\circ\text{C}$, pressure applied to port 2)

Characteristics	Min.	Typ.	Max.	Unit
Zero pressure offset	DC...G..	1		V
	DC...D..	3.5		
Full scale span ³	DC...G..	5.0		V
	DC...D..	±2.5		
Total accuracy (0 - 50 °C) ⁴	DC001N... DC2R5B...		±2.0	%FSO
	DC002N..., DC2R5N... DC005B...		±1.5	
	all others		±1.0	
Offset position sensitivity (±1 g)	DC001N... to DC2R5N... DC2R5B..., DC005B...			mV
	DC005N... DC010B...		±10	
	all others		±5	
			±1	

Notes:

³ Full scale span is the algebraic difference between the output voltage at full-scale pressure and the output at zero pressure.

⁴ Total accuracy includes non-linearity, hysteresis, repeatability, zero offset and span error, thermal effect on zero offset and span. Non-linearity refers to the **Best Straight Line** fit measured for offset pressure, full-scale pressure and ½ full-scale pressure.

ELECTRICAL CONNECTION

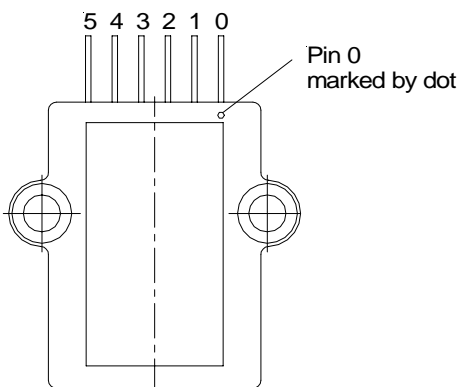

Pin no.	Output version		
	DC...C4 (4 Pin) 0.25..4.25 V ratiometric	DC...R4 (6 Pin) 0.25..4.25 V regulated	DC...R5 (6 Pin) 1..6 V regulated
0	no pin	N / C	N / C
1	+Vs	+Vs	+Vs
2	GND	GND	GND
3	Vout	Vout	Vout
4	I / C*	I / C*	I / C*
5	no pin	N / C	N / C

* Do not use for any reason

Note: The polarity indicated is for pressure applied to port 2

OUTLINE DRAWING

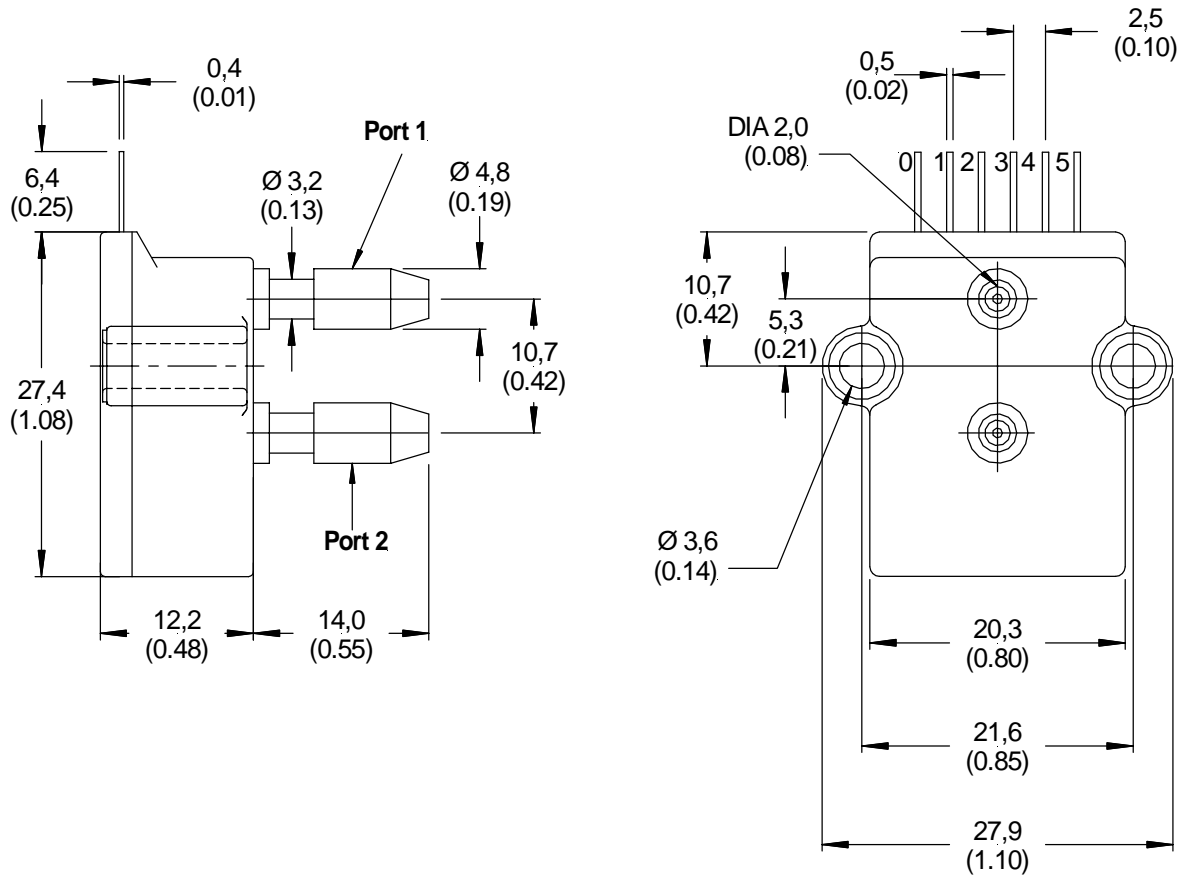

mass: approx. 10 g

dimensions mm (inches)

ORDERING INFORMATION

Pressure range	Output		
	0.25...4.25 V ratiometric	0.25...4.25 V regulated	1...6 V regulated
Differential/Gage			
0 to 1 "H ₂ O	DC001NGC4	DC001NGR4	DC001NGR5
0 to 2 "H ₂ O	DC002NGC4	DC002NGR4	--- ⁶
0 to 2.5 "H ₂ O	--- ⁶	--- ⁶	--- ⁶
0 to 5 "H ₂ O	DC005NGC4	DC005NGR4	DC005NGR5
0 to 10 "H ₂ O	DC010NGC4	--- ⁶	DC010NGR5
0 to 20 "H ₂ O	DC020NGC4	--- ⁶	--- ⁵
0 to 30 "H ₂ O	DC030NGC4	DC030NGR4	DC030NGR5
Differential (Pressure/vacuum)			
0 to ±1 "H ₂ O	DC001NDC4	DC001NDR4	DC001NDR5
0 to ±2 "H ₂ O	DC002NDC4	DC002NDR4	DC002NDR5
0 to ±2.5 "H ₂ O	DC2R5NDC4	DC2R5NDR4	DC2R5NDR5
0 to ±5 "H ₂ O	DC005NDC4	DC005NDR4	DC005NDR5
0 to ±10 "H ₂ O	DC010NDC4	DC010NDR4	DC010NDR5
0 to ±20 "H ₂ O	DC020NDC4	DC020NDR4	DC020NDR5
0 to ±30 "H ₂ O	DC030NDC4	DC030NDR4	DC030NDR5
Differential/Gage			
0 to 2.5 mbar	--- ⁶	--- ⁶	--- ⁶
0 to 5 mbar	--- ⁶	--- ⁶	--- ⁶
0 to 10 mbar	--- ⁶	--- ⁶	--- ⁶
0 to 25 mbar	DC025BGC4	--- ⁶	--- ⁶
0 to 50 mbar	DC050BGC4	--- ⁶	--- ⁶
0 to 75 mbar	--- ⁶	--- ⁶	--- ⁶
Differential (Pressure/vacuum)			
0 to ±2.5 mbar	DC2R5BDC4	--- ⁶	DC2R5BDR5
0 to ±5 mbar	DC005BDC4	--- ⁶	--- ⁶
0 to ±10 mbar	DC010BDC4	DC010BDR4	DC010BDR5
0 to ±25 mbar	DC025BDC4	DC025BDR4	DC025BDR5
0 to ±50 mbar	DC050BDC4	DC050BDR4	DC050BDR5
0 to ±75 mbar	DC075BDC4	DC075BDR4	DC075BDR5

Note

⁶ These devices are available on special request. Minimum order quantity may apply.

Sensortech reserves the right to make changes to any products herein. Sensortech does not assume any liability arising out of the application or use of any product or circuit described herein, neither does it convey any license under its patent rights nor the rights of others.



Компания «ЭлектроПласт» предлагает заключение долгосрочных отношений при поставках импортных электронных компонентов на взаимовыгодных условиях!

Наши преимущества:

- Оперативные поставки широкого спектра электронных компонентов отечественного и импортного производства напрямую от производителей и с крупнейших мировых складов;
- Поставка более 17-ти миллионов наименований электронных компонентов;
- Поставка сложных, дефицитных, либо снятых с производства позиций;
- Оперативные сроки поставки под заказ (от 5 рабочих дней);
- Экспресс доставка в любую точку России;
- Техническая поддержка проекта, помощь в подборе аналогов, поставка прототипов;
- Система менеджмента качества сертифицирована по Международному стандарту ISO 9001;
- Лицензия ФСБ на осуществление работ с использованием сведений, составляющих государственную тайну;
- Поставка специализированных компонентов (Xilinx, Altera, Analog Devices, Intersil, Interpoint, Microsemi, Aeroflex, Peregrine, Syfer, Eurofarad, Texas Instrument, Miteq, Cobham, E2V, MA-COM, Hittite, Mini-Circuits, General Dynamics и др.);

Помимо этого, одним из направлений компании «ЭлектроПласт» является направление «Источники питания». Мы предлагаем Вам помощь Конструкторского отдела:

- Подбор оптимального решения, техническое обоснование при выборе компонента;
- Подбор аналогов;
- Консультации по применению компонента;
- Поставка образцов и прототипов;
- Техническая поддержка проекта;
- Защита от снятия компонента с производства.



Как с нами связаться

Телефон: 8 (812) 309 58 32 (многоканальный)

Факс: 8 (812) 320-02-42

Электронная почта: org@eplast1.ru

Адрес: 198099, г. Санкт-Петербург, ул. Калинина, дом 2, корпус 4, литера А.