

## DESCRIPTION

Demonstration circuit 1223A-B facilitates communication between PC-based user interface software and Linear Technology SMBus/I<sup>2</sup>C demonstration boards. DC1223A-B connects to the computer via USB. It receives power from the USB and isolates the computer ground from the SMBus/I<sup>2</sup>C demonstration board. DC1223A-B adds to DC1223A, the SMBus monitoring feature. The DC1223A-B can be used in three ways, depending on the software available for the demonstration board under evaluation (DBUE):

### QuikEval Mode

QuikEval<sup>®</sup> mode is the easiest way to communicate with a Linear Technology SMBus/I<sup>2</sup>C demonstration board. However this is limited to newer battery charger demo boards like the DC1259A. QuikEval application-specific user interfaces are available at <http://www.linear.com/designtools/software/>. Figure 2 shows an example of an application-specific user interface for the DC1259A demo board.

### General User Interface Mode

General user interface mode is for demo boards that do not offer customized software. The general user interface is PC-based, and graphical, but not application specific. It can send out discrete commands to any SMBus/I<sup>2</sup>C device (see Figure 2 and Appendix A), supporting nine different SMBus command protocols: Send Byte, Receive Byte,

Write Byte, Read Byte, Write Word, Read Word, Block Write, Block Read and Block Write-Read Process calls. It also supports additional command protocols for PMBus: Extended Read Byte, Extended Write Byte, Extended Read Word, Extended Write Word and Group Send. It can also monitor the SMBus traffic of an existing communication between a master and a slave. Contact the Linear Technology sales department for the latest general user interface software.

### DC410 Emulation Mode (Windows XP Only)

A number of Linear Technology demonstration boards offer software for use with the DC410 Serial Port-to-SMBus Interface Board, e.g. DC285 (LTC1695), DC182 (LT1786F), DC286 (LTC1960), DC486 (LTC1760), DC496 (LTC4008), and DC512 (LTC4100). For these boards, the DC1223A-B can be used to replace DC410. These demo boards have application-specific user interface programs but they are not part of the QuikEval software program. These application-specific programs are available from Linear Technology sales department.

**Note:** This is not a standard mode of operation. Please see detailed Instructions in Appendix B to replace DC410 with DC1223A-B .

**Design files for this circuit board are available at <http://www.linear.com/demo/DC1223A-B>**

LT, LT, LTC, LTM, Linear Technology and the Linear logo are registered trademarks and QuikEval is a trademark of Linear Technology Corporation. All other trademarks are the property of their respective owners.

## QUICK START PROCEDURE (QuikEval MODE)

Demonstration circuit 1223A-B is easy to set up to evaluate the performance of Linear Technology SMBus/I<sup>2</sup>C demonstration boards DC1223A-B. Refer to Figure 1 for proper measurement equipment setup and follow the procedure below.

**Note:** The DC1223A-B is powered from the Host PC via USB.

1. Download the QuikEval software from <http://www.linear.com/designtools/software/>. Follow the installation instructions carefully.
2. When prompted to plug in the demo board, first connect the USB cable to the DC1223A-B and then connect the Demonstration Board Under Evaluation (DBUE) to the DC1223A-B. Power up the DBUE as recommended in its Quick Start Guide.

3. Check to see if there are already pull-up resistors on the DBUE. If yes, set jumpers JP1 and JP2 on DC1223A-B to Open.
4. Check to make sure jumper JP4 is on "Direct". JP4 should only be on "VCP" if it is doing RS232 emulation for replacing DC410. See Appendix B for this feature.
5. The "Found New Hardware Wizard" window may pop up. If it does then choose the "Recommended" Installation.

**NOTE:** If Windows cannot find the device driver, then select "Install from a list or specific location(Advanced)". Enter the installation path as "C:\Program Files\LTC\QuikEval\driver".

The associated software for the DBUE should pop up.

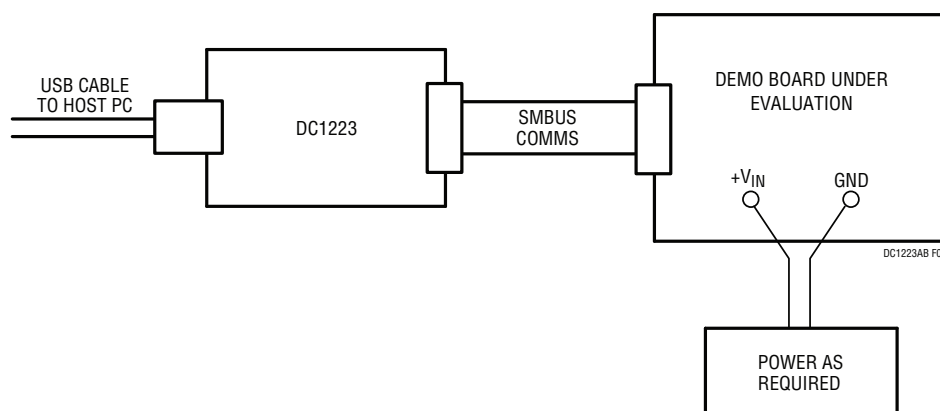

Figure 1. Typical Equipment Setup

# QUICK START PROCEDURE (QuikEval MODE)

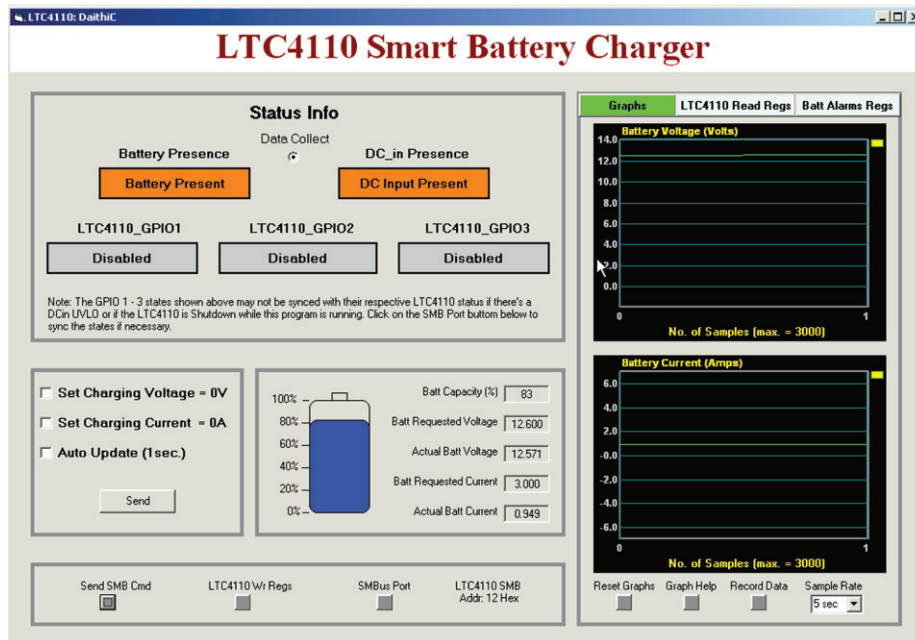

Figure 2. DC1259A Application-Specific User Interface Program (QuikEval)

## APPENDIX A: USING DC1223A-B'S GENERAL USER INTERFACE

1. Make sure you have the latest version of DC1223AB.zip. Do not connect the USB cable to the PC yet. Install the DC1223A-B.msi software if not already done. <http://www.linear.com/designtools/software/>.

**Note:** For Windows Vista users, please follow the instructions available in the DC1223A-B.zip folder. Read the “Installing DC1223AB\_Vista.htm” file.

2. **Move JP4 of DC1223A-B to Direct if it is not already done. This is very important!**
3. Download the QuikEval software from <http://www.linear.com/designtools/software/>. Follow the installation instructions carefully.
4. When prompted to plug in the demo board, first connect the USB cable to the DC1223A-B and then connect the Demonstration Board Under Evaluation (DBUE) to the DC1223A-B. Power up the DBUE as recommended in its Quick Start Guide.
5. Connect the hardware the same way as shown in Figure 6.

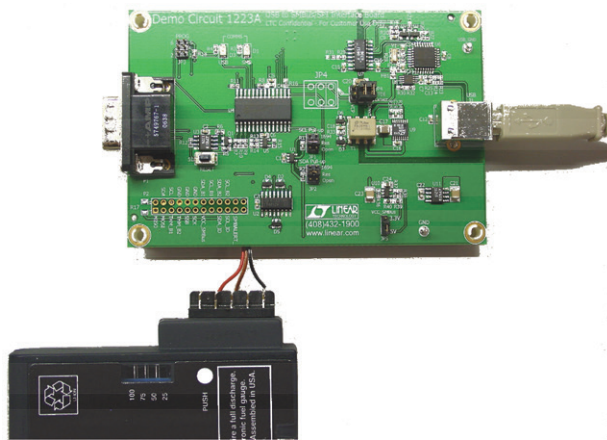

Figure 3. SCL, SDA, GND Connections to Any SMBus Device

**Note:** It is not necessary to use a DC486. Any SMBus device with SCL, SDA, GND can be connected to DC1223A-B via the P2 connector. For example you can use a smart battery as a SMBus device as shown in Figure 6. Smart battery is a master/slave device.

6. Launch DC1223A-B\_Monitor.exe.
7. A General User Interface window appears as shown in Figure 4. Input the slave address and the commands to talk to the smart battery or LTC1760. 16HEX is the slave address of the smart battery. A 16HEX device command is the AlarmWarning() command sent to the battery. The read word result is 00C0HEX, meaning no alarms raised except that the battery is currently discharging. For more information about the meaning of device command 16HEX go to View → SBS → SBS Table.
8. To go into SMBus Monitor mode, go to Tools → Monitor. You will see the windows in Figure 5. For more detail instructions go to Help → Help Topics.

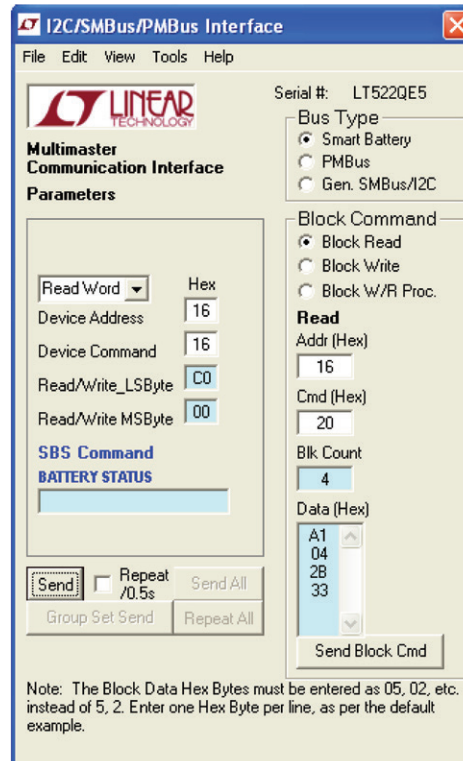

Figure 4. General User Interface for SMBus Communication

**APPENDIX A: USING DC1223A-B'S GENERAL USER INTERFACE**

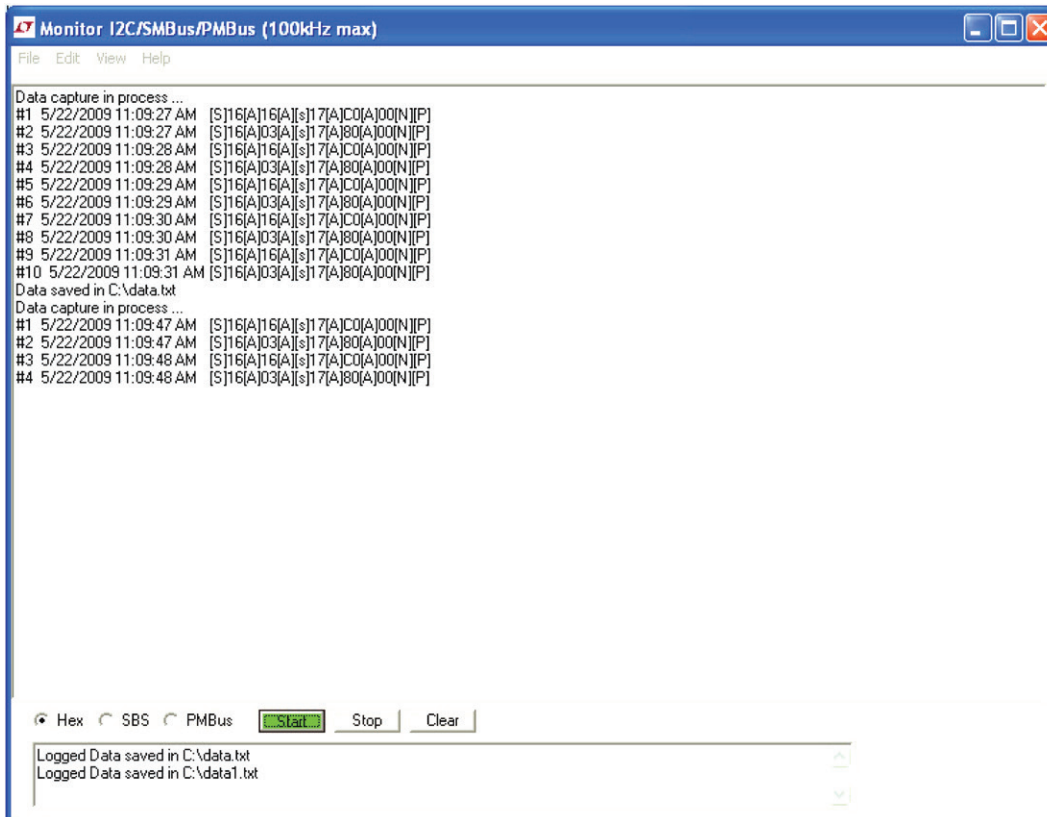

Figure 5. General User Interface SMBus Monitor Mode

## APPENDIX B: DC410 EMULATION MODE (WINDOWS XP ONLY)

A number of older battery charger demonstration boards, including the DC286 (LTC1960), DC486 (LTC1760), DC496 (LTC4008) and DC512 (LTC4100) used the DC410 to send SMBus commands to/from a PC via a serial RS232 com port. The software developed for this configuration was based on Labview. This software is provided when you order these older demo boards.

Please contact Linear Technology Applications if you need a copy. However, as RS232 is disappearing, and is being replaced by USB, the DC1223A-B replaces the DC410. The DC1223A-B can be used to emulate a RS232 com port for backwards compatibility with the existing application-specific Labview software.

**Note:** If you don't want to use the legacy Labview software which requires RS232 emulation, you can alternatively use a General User Interface(GUI) software developed to communicate using DC1223A-B which does not require RS232 emulation (use USB directly). However you will be missing the user friendly interface specific to a particular device, for example the LTC1760, LTC4100 or LTC1960 available in the legacy Labview program. Instead the GUI requires you to input the parameters yourself. For the GUI program, skip the below instructions and go to the Appendix A.

So the new configuration is a DC486 (for example) and a DC1223A-B. The same Labview software can still be used. However, you need to follow these steps as it involved RS232 emulation.

### Installing Software to Emulate DC410 (RS232)

1. Connect the hardware as shown in Figure 6. Do not connect the USB port to the computer yet.
2. DC1223A-B jumper positions should be:

JP5 on "5V"

JP4 on "VCP" (Virtual Com Port)

**Note:** This is a very important step. When you change the jumper to JP4, you are telling the FTDI chip to emulate a RS232 port. If JP4 is on "Direct", the FTDI chip will communicate directly as a USB.

3. Install DC1223A-B.msi, but don't run it. If you need a copy of the software please go to <http://www.linear.com/designtools/software/>.

**Note:** For Windows Vista users, please follow the instructions available in the DC1223A-B.zip folder. Read the "Installing DC1223AB\_Vista.htm" file.

4. Download the QuikEval software from <http://www.linear.com/designtools/software/>. Follow the installation instructions carefully.
5. When prompted to plug in the demo board, first connect the USB cable to the DC1223A-B and then connect the Demonstration Board Under Evaluation (DBUE) to the DC1223A-B. Power up the DBUE as recommended in its Quick Start Guide.
6. Go to the computer's device manager by choosing (Start → Control Panel → System → Hardware tab Device Manager). Look at the ports (COM and LPT).

Notice the USB Serial Port (COM4). This tells you that a Virtual Com Port now exists (the USB emulated a RS232 com port) so that you can continue using the legacy Labview program. See Figure 8.

7. If the RS232 com port emulated is higher than 4, please change it to any number between 1 and 4 by right clicking on ports (COM & LPT), select the Port Settings tab and select Advanced. Change the Com port number to a number from 1 to 4. See Figure 9.
8. Launch the software for the demo board under evaluation (e.g., DC486) and when prompted to enter the RS232 com port, use the number you obtained from step 8. If you need a copy of the software please contact Linear Technology Sales Department. For DC486, you will need dc486v2.exe. See Figure 10.

**APPENDIX B: DC410 EMULATION MODE (WINDOWS XP ONLY)**

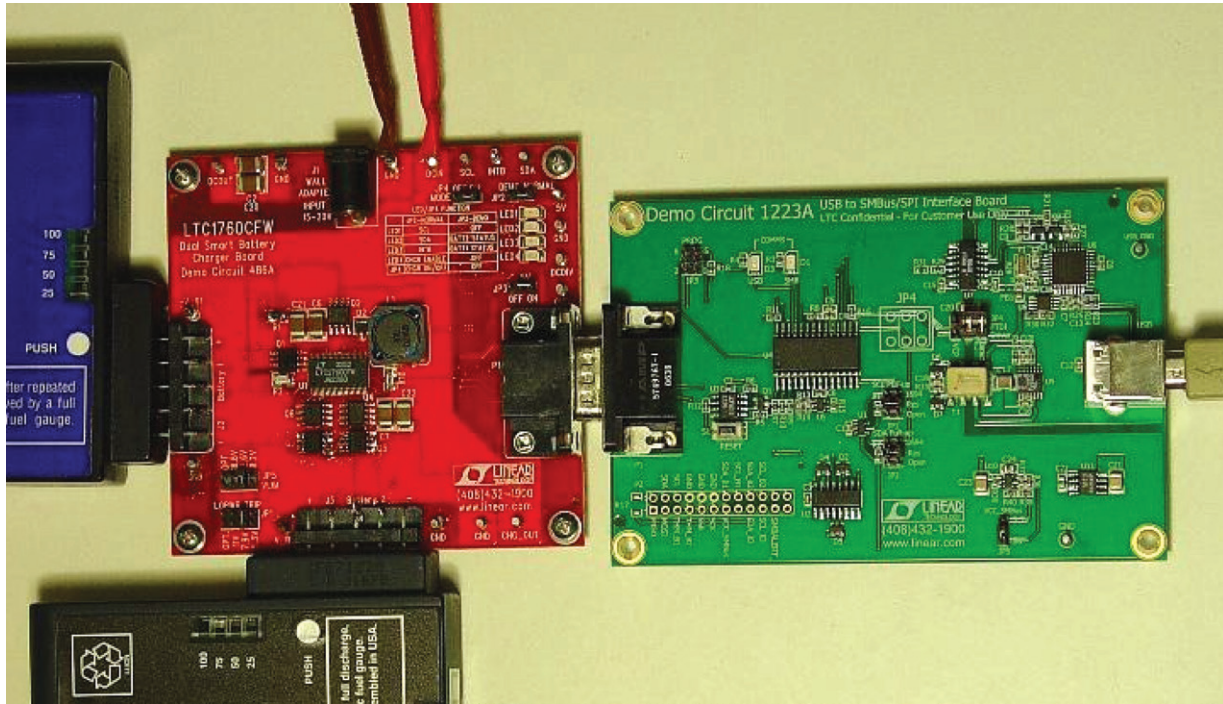

Figure 6. Hardware Setup Between a DC1223A-B and a DC486 (Can Be DC512, DC486, DC286, Etc.). JP4 Should Be on VCP.

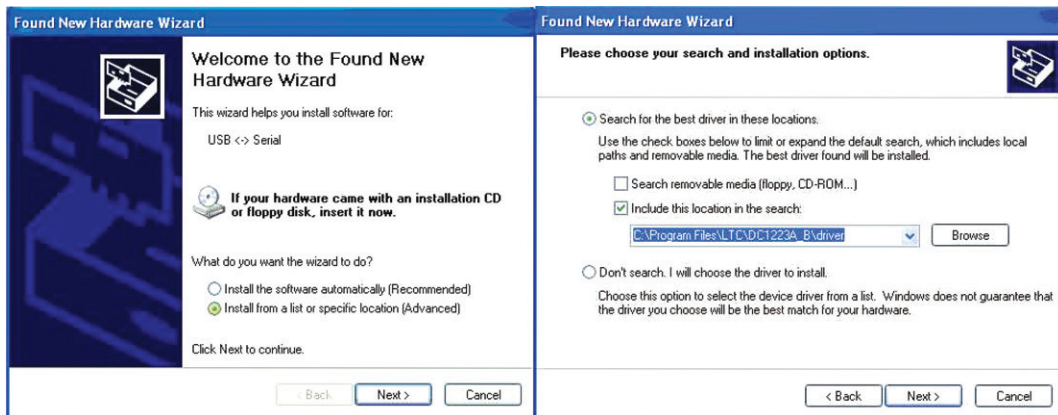

Figure 7. Driver Installation

## APPENDIX B: DC410 EMULATION MODE (WINDOWS XP ONLY)

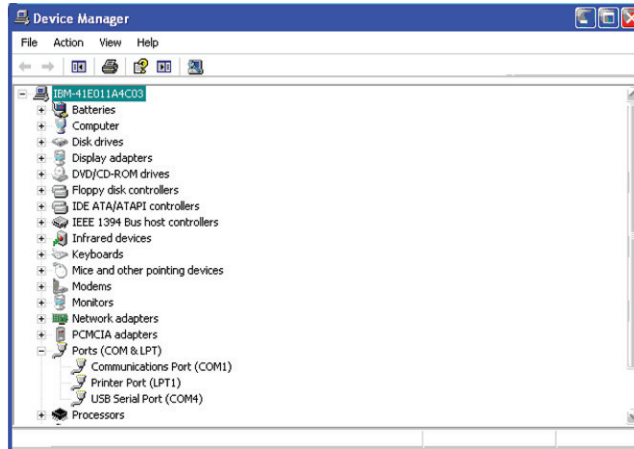

Figure 8. Device Manager

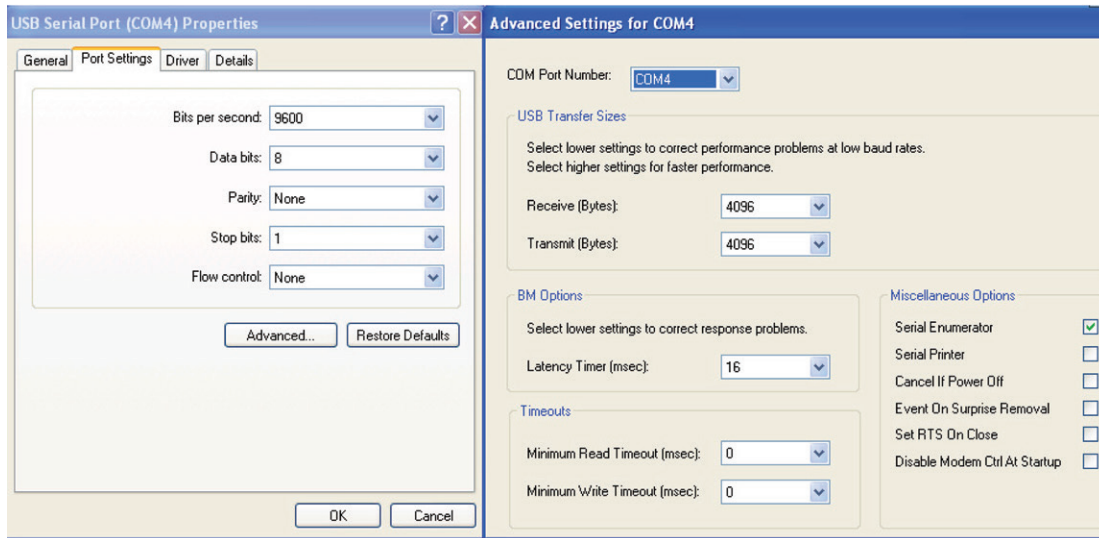

Figure 9. Change the COM Port that USB is Emulating



**APPENDIX B: DC410 EMULATION MODE (WINDOWS XP ONLY)**

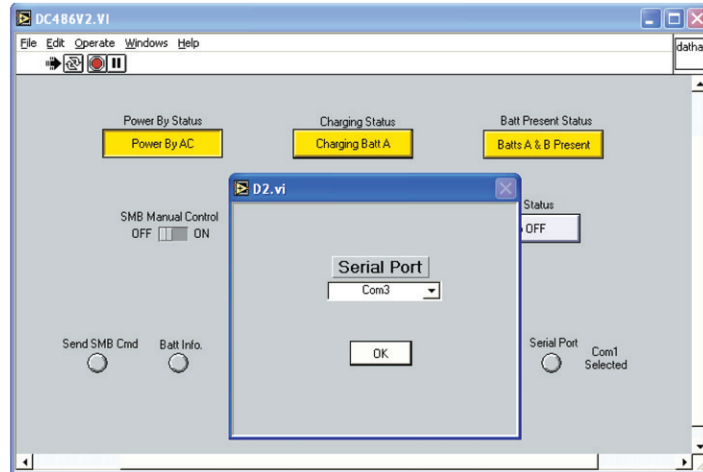

Figure 10. Launch DC486 Software and Select the COM Port Emulated in Step 8

# DEMO MANUAL DC1223A-B

## APPENDIX C: SCHEMATICS AND BILL OF MATERIALS

ITEM	QTY	REFERENCE	PART DESCRIPTION	MANUFACTURER/PART NUMBER
1	15	C1-C3, C5-C11, C13-C16, C18	CAP., X7R 0.1 $\mu$ F 16V 10%	AVX 0603YC104KAT2A
2	1	C4	CAP., X5R 1 $\mu$ F 16V 10%	TAIYO YUDEN EMK107BJ105KA-T
3	1	C12	CAP., X7R 0.01 $\mu$ F 25V 10%	AVX 06033C103KAT2A
4	1	C17	CAP., X5R 100 $\mu$ F 6.3V 20%	TAIYO YUDEN JMK325BJ107MM-T
5	1	C19	CAP., NPO 330pF 25V 5%	AVX 06033A331JAT2A
6	1	C20	CAP., X7R 2200pF 1kV 20%	AVX 1206AC222MAT2A
7	2	C21, C23	CAP., X5R 22 $\mu$ F 25V 20%	AVX 12103D226MAT2A
8	2	C22, C24	CAP., X5R 10 $\mu$ F 10V 10%	TAIYO YUDEN LMK212BJ106KG-T
9	2	D1, D3	LED, GRN	PANASONIC LN1351CTR
10	3	D2, D4, D5	SCHOTTKY (COMM-ANODE) DIODE	DIODE INC. BAT54A-7-F
11	2	D6, D7	SCHOTTKY DIODE, DUAL SOT23	DIODES INC. BAT54S-7-F
12	2	E1, E2	TURRET, TESTPOINT	MILL MAX 2308-2-00-80-00-00-07-0
13	1	FB1	FERRITE BEAD, PBF	STEWART MI0805K400R-10
14	3	JP1-JP3	HEADERS, DBL. ROW 2 $\times$ 3 2mm CTRS.	SAMTEC, TMM-103-02-L-D
15	1	JP4	HEADERS SQ. POST, DBL. ROW 2 $\times$ 3, 0.1mm CTRS.	SAMTEC, TSW-103-07-L-D
16	1	JP5	HEADERS, 1 $\times$ 3, 2mm CTRS.	SAMTEC TMM-103-02-L-S
17	1	J1	USB CONN, TYPE B RECEPTACLE	MILL-MAX 897-43-004-90-000000
18	1	P1	CONN, DB15-M 2mm	AMP INC. 574-9767-1
19	1	P2	HEADERS, DBL. ROW 0.1mm CTRS.	SAMTEC TSW-112-07-L-D
20	1	Q1	XSTR. NPN 40V 350mW SMD SOT23	DIODES INC. MMBT3904-7-F
21	2	Q2,Q3	MOSFET, N-CH. 60V 115mA SOT23	DIODES INC. 2N7002-7-F
22	3	R1, R2, R8	RES., CHIP, 15k, 0.1W, 5%, 0603	YAGEO, RC0603JR-0715KL
23	2	R3,R4	RES., CHIP, 750 $\Omega$ , 0.1W, 5%, 0603	YAGEO, RC0603JR-07750RL
24	11	R5, R6, R9, R10, R12, R16, R19, R32-R34, R36	RES., CHIP, 10k, 0.1W, 5%, 0603	PANASONIC ERJ3GEYJ103V
25	2	R7, R37	RES., CHIP, 49.9k, 1/16W, 1%, 0603	YAGEO, RC0603FR-0749K9L
26	1	R11	RES., CHIP, 5.1k, 0.1W, 5%, 0603	PANASONIC ERJ-3GEYJ512V
27	1	R13	RES., CHIP, 5.11k, 1/16W, 1%, 0603	NIC COMP. CORP., NRC06F5111TRF
28	1	R14	RES., CHIP, 80.6 $\Omega$ , 1/16W, 1%, 0603	YAGEO, RC0603FR-0780R6L
29	3	R15, R26, R29	RES/JUMPER, CHIP, 0, 1 AMP, 0603	YAGEO, RC0603FR-070RL
30	0	R17 (OPT)	RES/JUMPER, CHIP, 0, 1 AMP, 1206	YAGEO, RC1206FR-070RL
31	2	R18, R25	RES., CHIP, 1.5k, 0.1W, 5%, 0603	YAGEO, RC0603JR-071K5L
32	1	R20	RES., CHIP, 100k, 0.1W, 5%, 0603	VISHAY, CRCW0603100KJNEA
33	2	R21, R28	RES., CHIP, 1M $\Omega$ , 0.1W, 5%, 0603	YAGEO, RC0603JR-071ML
34	1	R22	RES., CHIP, 470 $\Omega$ , 0.1W, 5%, 0603	YAGEO, RC0603JR-07470RL
35	2	R23, R24	RES., CHIP, 27 $\Omega$ , 0.1W, 5%, 0603	YAGEO, RC0603JR-0727RL
36	0	R27, R31 (OPT)	RES/JUMPER, CHIP, 0, 1A	YAGEO, RC0603FR-070RL
37	1	R30	RES., CHIP, 2.2k, 0.1W, 5%, 0603	YAGEO, RC0603JR-072K2L
38	1	R35	RES., CHIP, 16.9k, 0.1W, 1%, 0603	VISHAY, CRCW060316K9FKEA
39	1	R38	RES., CHIP, 26.7k, 0.1W, 1%, 0603	YAGEO, RC0603FR-0726K7L

**APPENDIX C: SCHEMATICS AND BILL OF MATERIALS**

ITEM	QTY	REFERENCE	PART DESCRIPTION	MANUFACTURER/PART NUMBER
40	1	R39	RES., CHIP, 102k, 0.1W, 1%, 0603	YAGEO, RC0603FR-07102KL
41	1	R40	RES., CHIP, 41.2k, 0.1W, 1%, 0603	YAGEO, RC0603FR-0741K2L
42	1	S1	SWITCH, EVQPJS05K	PANASONIC EVQPJS05K
43	1	T1	TRANSFORMER, 2.5:1:1	PULSE PA0510NLT
44	1	U1	I.C., SMBUS ACCELERATOR	LINEAR TECH. CORP. LTC1694CS5
45	1	U2	I.C., ANALOG MULTIPLEXER	TEXAS INST. SN74LV4052ADRE4
46	1	U3	I.C., 3-SUPPLY MONITOR	LINEAR TECH. CORP. LTC1326CS8
47	1	U4	I.C., MICROCONTROLLER, (#FW410V3) PROGRAM	MICROCHIP, PIC16F76-I/SO
48	1	U5	I.C., LOW PWR. RESISTOR SET OSC.	LINEAR TECH. CORP. LTC1799CS5
49	1	U6	I.C., SERIAL DATA TRANSFER	FUTURE TECH. DEVICES INT'L FT232BL(PBF)
50	1	U7	I.C., ISOLATOR NARROW BODY	AVAGO TECH. HCPL-091J-000E (PBF)
51	1	U8	I.C., EEPROM	MICROCHIP 93C46B-I/MS
52	1	U9	I.C., DC/DC XFMR DRIVER	LINEAR TECH. CORP. LT3439EFE
53	1	U10	I.C., LDO REGULATOR	LINEAR TECH. CORP. LT1761ES5-SD
54	1	U11	I.C., LOW DROPOUT W/SHUTDOWN	LINEAR TECH. CORP. LT1121CS8-5
55	3	XJP1 - XJP2, XJP5	SHUNT, 2mm CTRS.	SAMTEC 2SN-BK-G
56	1	XJP4	SHUNT, 2 x 2, 0.1mm CTRS.	SAMTEC MNT-102-BK-G
57	1	Y1	CER. RESONATOR, 6MHZ	MURATA CSTCR6M00G15L**-R0
58	4	MTG 4 CORNERS	STAND-OFF, NYLON, 0.25 TALL	KEYSTONE, 8831 (SNAP ON)
59	1		CABLE A-B MALE DBL SHIELD 2M	ASSMANN ELECTRONICS AK672
60	1		MINIGRABBER TEST CLIP PATCH CORD, BLACK	POMONA 3781-12-0
61	1		MINIGRABBER TEST CLIP PATCH CORD, BLUE	POMONA 3781-12-6
62	1		MINIGRABBER TEST CLIP PATCH CORD, WHITE	POMONA 3781-12-9
63	1		FAB, 1223A_REV2.PCB	DEMO CIRCUIT 1223A-B
64	1		STENCIL: ST-1223A-REVO	STENCIL 1223A

# DEMO MANUAL DC1223A-B

## APPENDIX C: SCHEMATICS AND BILL OF MATERIALS

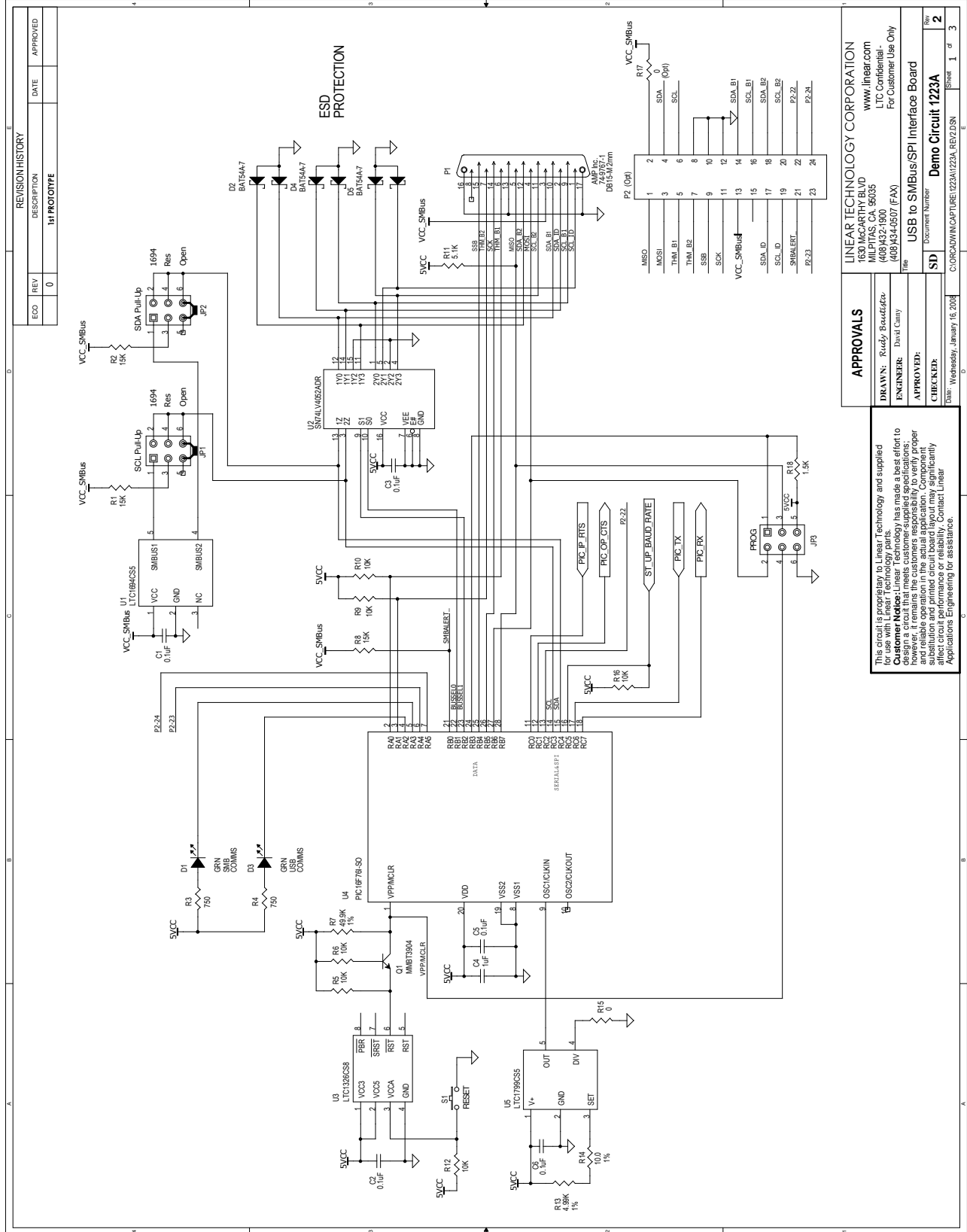

REVISION HISTORY		
ECO	REV	DESCRIPTION
	0	1st PROTOTYPE

APPROVALS	
DRAWN BY: <i>Stacy Bazzaz</i>	DATE: <i>Wednesday, January 16, 2008</i>
ENGINEER: <i>David Camy</i>	
APPROVED:	
CHECKED:	

This circuit is proprietary to Linear Technology and supplied for use with Linear Technology parts. Applications Engineering has made a best effort to design a circuit that meets customer supplied specifications; however, it remains the customer's responsibility to verify proper operation of the circuit. Components are not guaranteed to be available in the quantities specified and are not guaranteed to be available in the quantities specified. Contact Linear Applications Engineering for assistance.

LINEAR TECHNOLOGY CORPORATION	
100 N. Lincoln Ave.	www.linear.com
Milpitas, CA 95035	(408)432-1900
	(408)434-6507 (FAX)
	For Customer Use Only
File: <b>USB to SMBus/SPI Interface Board</b>	
Doc: <b>SD</b>	Document Number: <b>SD</b>
Title: <b>Demo Circuit 1223A</b>	
C:\CORAD\ADMIN\CAPTURE\1223A\1223A-REV2.DSN	
Sheet: <b>1</b>	of: <b>3</b>



## APPENDIX C: SCHEMATICS AND BILL OF MATERIALS

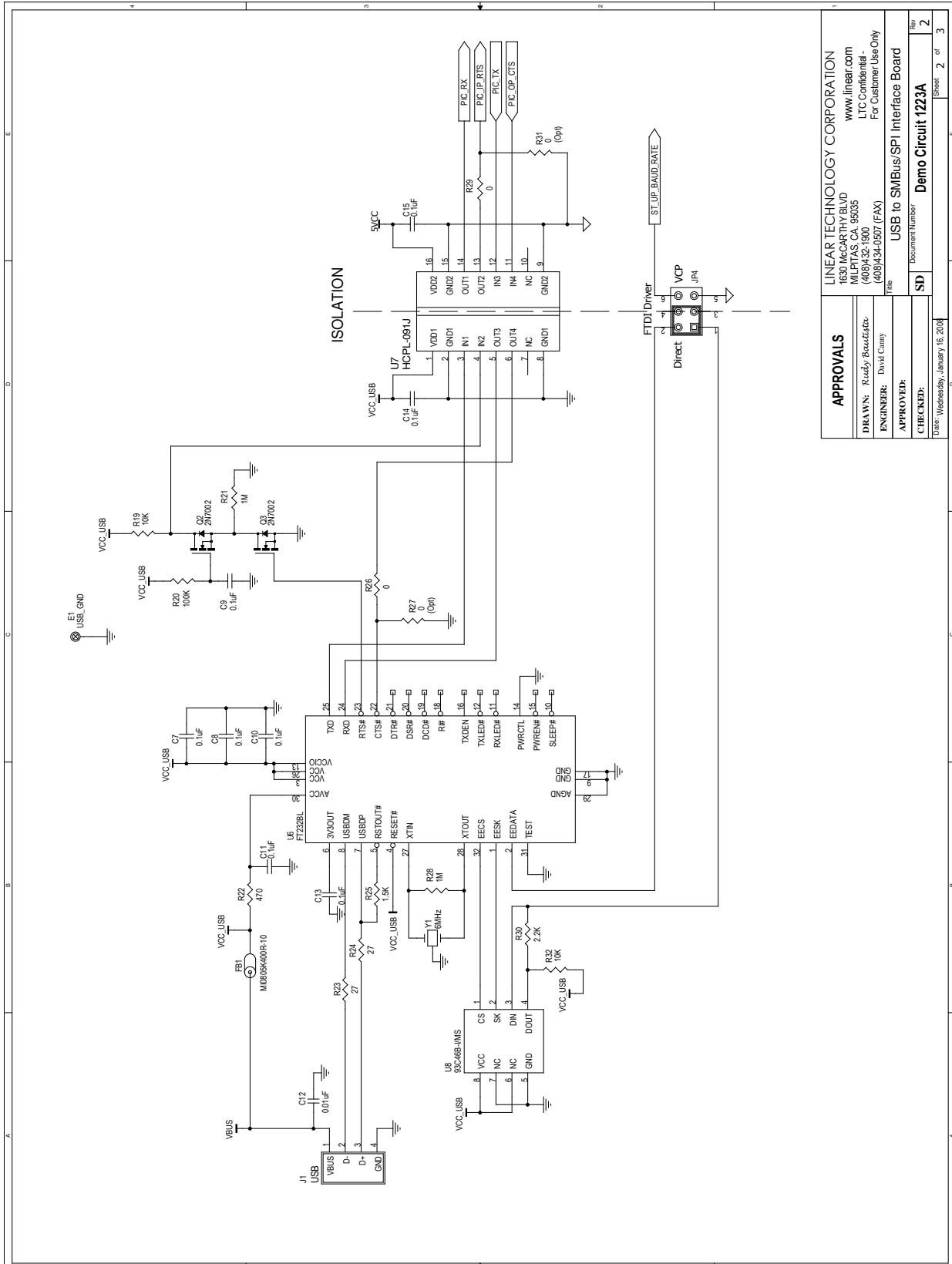

APPROVALS	
DRAWN: Rudy Baedera	www.linear.com
ENGINEER: David Cuny	MILPITAS, CA, 95035
APPROVED:	LTC Confidential - For Customer Use Only
CHECKED:	File: USB to SMBus/SPI Interface Board
Date: Wednesday, January 16, 2008	Document Number: <b>DC1223A</b>
	Sheet 2 of 3

## APPENDIX C: SCHEMATICS AND BILL OF MATERIALS

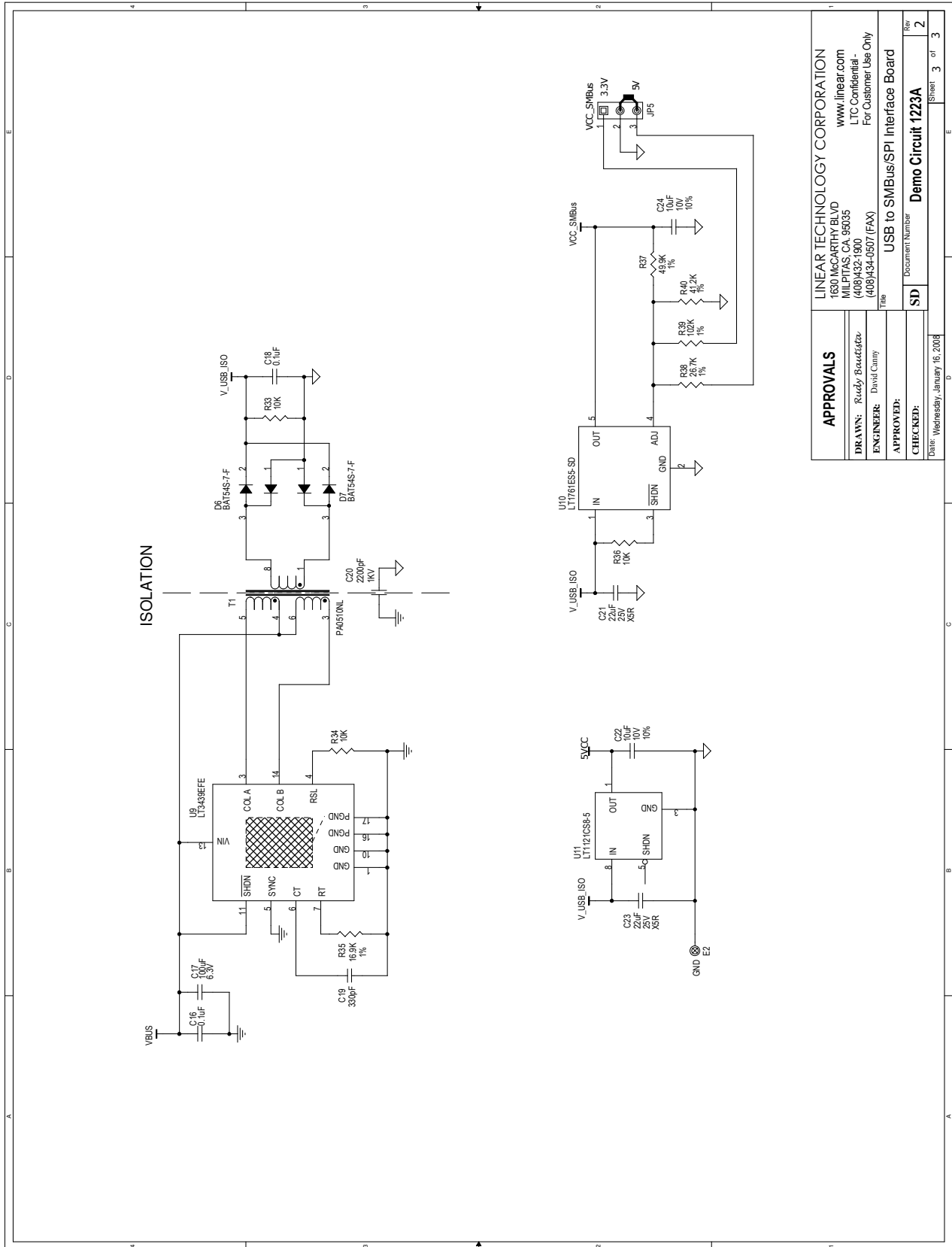

APPENDIX C: SCHEMATICS AND BILL OF MATERIALS

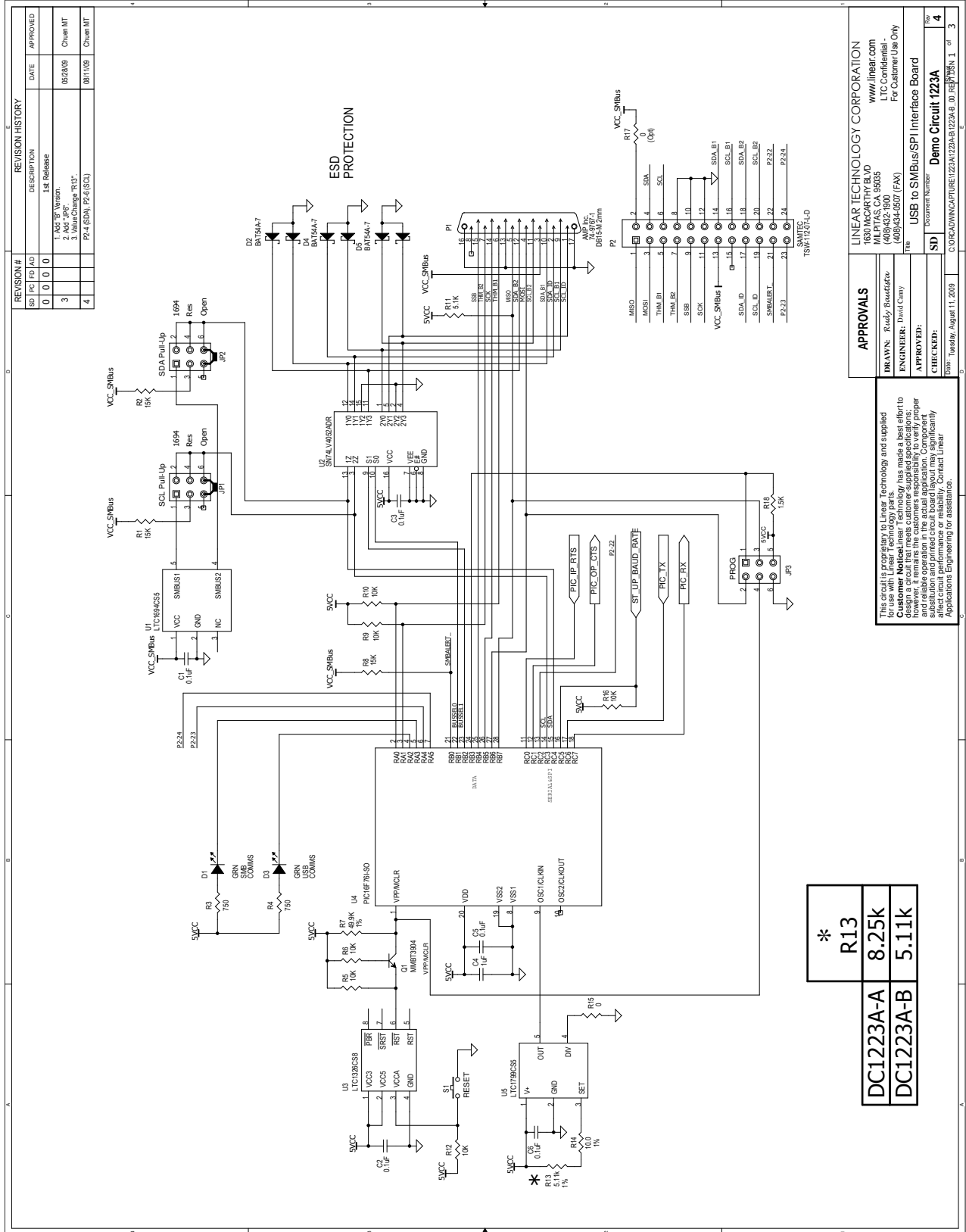

REVISION #		REVISION HISTORY		DATE		APPROVED	
SD	PC	FD	AD	DESCRIPTION			
0	0	0	0	1st Release			
3				1. Add 'B' Revision. 2. Add 'JPG'.			Chun MT
4				3. Value Change 'R13'.			Chun MT
				P24 (SDA), P28 (SCL)			08/11/09

APPROVALS		LINEAR TECHNOLOGY CORPORATION	
DRAWN:	Rudy Rowcliffe	1830 MCCARTHY BLVD	www.linear.com
ENGINEER:	David Cully	MILPITAS, CA 95035	LTC Confidential
APPROVED:		(408) 632-7900	For Customer Use Only
CHECKED:		Fax: (408) 645-5207 (FAX)	
Doc Number:	USB to SMBus/SPI Interface Board	Account Number:	Demo Circuit 1223A
SD		Rev	4
Date:	Tuesday, August 11, 2009	Doc Ref ID:	001223A-B-00-REF ID: A6N_1

This circuit is proprietary to Linear Technology and supplied for use with Linear Technology parts.  
**Customer Notice:** Linear Technology has made a best effort to ensure the accuracy of the information provided in this document; however, it remains the customer's responsibility to verify proper and reliable operation in the actual application. Component values are shown for illustrative purposes only and do not necessarily affect circuit performance or reliability. Contact Linear Applications Engineering for assistance.

## APPENDIX C: SCHEMATICS AND BILL OF MATERIALS

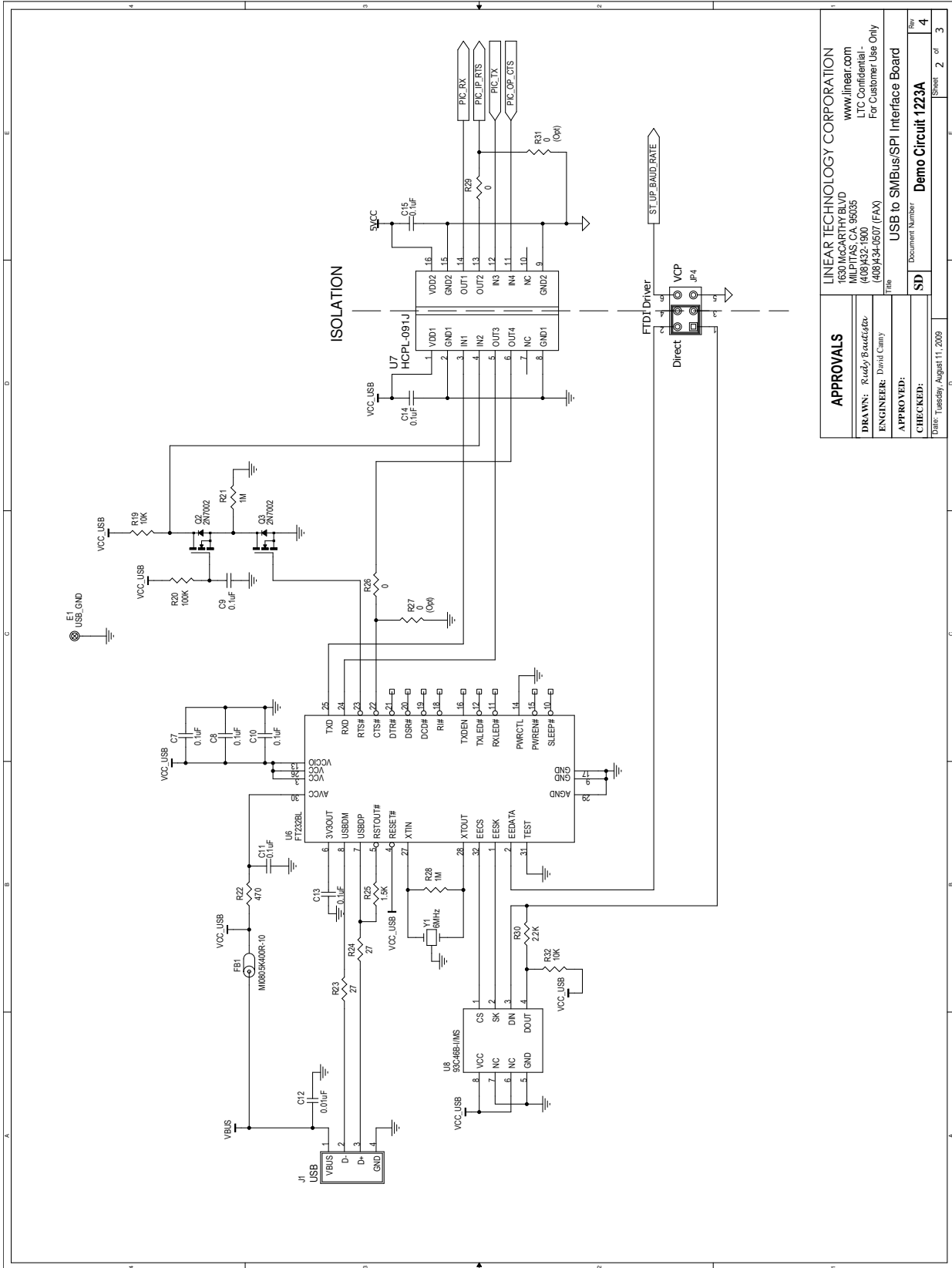

<b>APPROVALS</b>		<b>LINEAR TECHNOLOGY CORPORATION</b>	
DRAWN: Rudy Brackley	1630 MCCARTHY BLVD MILLPITAS, CA 95035 www.linear.com LTC Confidential For Customer Use Only		
APPROVED: David Camy	Title: <b>USB to SMBus/SPI Interface Board</b>		
CHECKED: SD	Document Number:	4	Rev: 4
Date: Tuesday, August 11, 2009	Sheet:	2	of 3



APPENDIX C: SCHEMATICS AND BILL OF MATERIALS

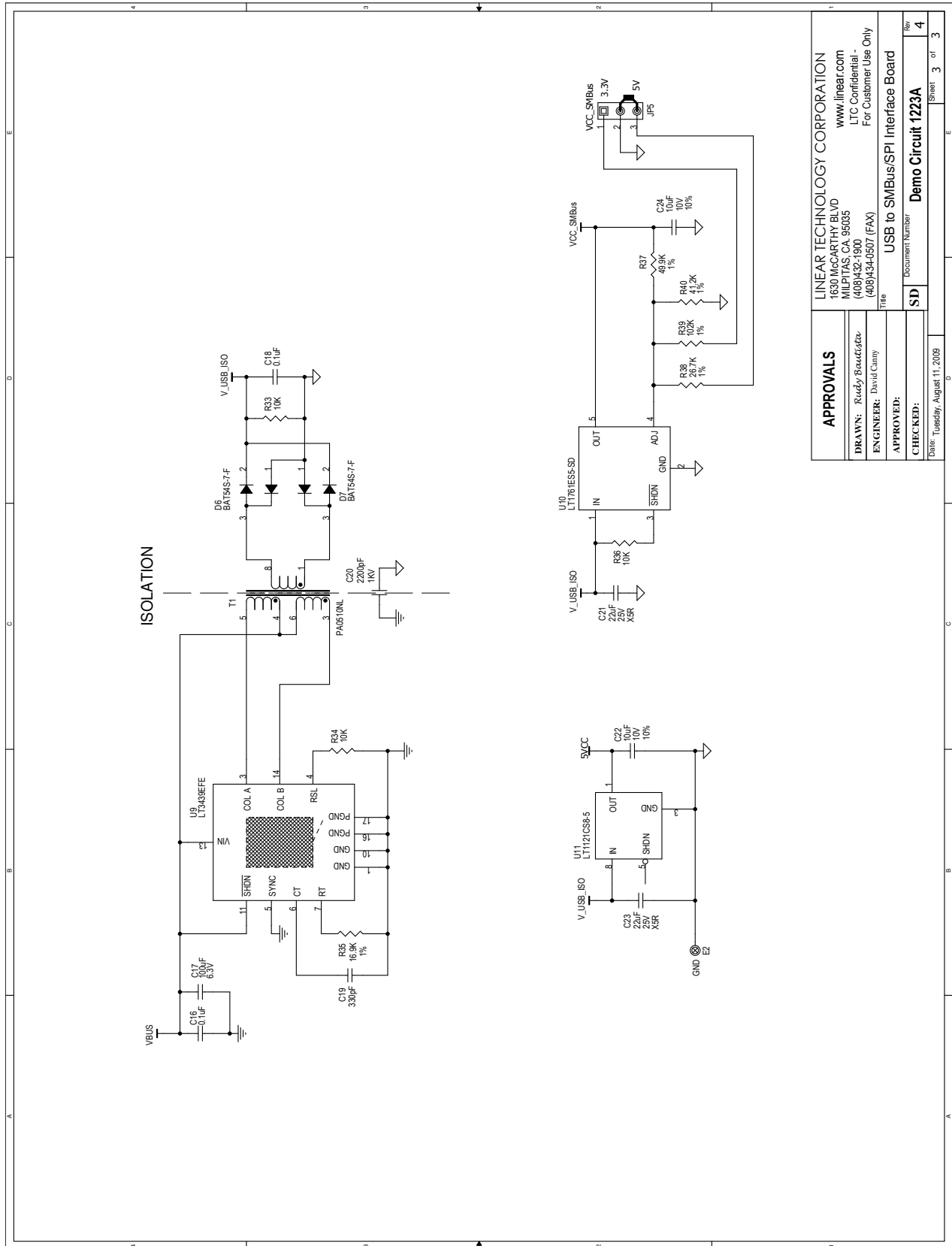

<b>APPROVALS</b>		LINEAR TECHNOLOGY CORPORATION 1630 MCCARTHY BLVD MILPITAS, CA 95035 www.linear.com	
DRAWN: Rudy Beaudette		LTC Confidential - For Customer Use Only	
ENGINEER: David Campy		Title: USB to SMBus/SPI Interface Board	
APPROVED:		Document Number: <b>DC1223A</b>	
CHECKED: Tuesday, August 11, 2009		Rev: <b>4</b>	
		Sheet: <b>3</b> of <b>3</b>	



Information furnished by Linear Technology Corporation is believed to be accurate and reliable. However, no responsibility is assumed for its use. Linear Technology Corporation makes no representation that the interconnection of its circuits as described herein will not infringe on existing patent rights.

# DEMO MANUAL DC1223A-B

---

## DEMONSTRATION BOARD IMPORTANT NOTICE

Linear Technology Corporation (LTC) provides the enclosed product(s) under the following **AS IS** conditions:

This demonstration board (DEMO BOARD) kit being sold or provided by Linear Technology is intended for use for **ENGINEERING DEVELOPMENT OR EVALUATION PURPOSES ONLY** and is not provided by LTC for commercial use. As such, the DEMO BOARD herein may not be complete in terms of required design-, marketing-, and/or manufacturing-related protective considerations, including but not limited to product safety measures typically found in finished commercial goods. As a prototype, this product does not fall within the scope of the European Union directive on electromagnetic compatibility and therefore may or may not meet the technical requirements of the directive, or other regulations.

If this evaluation kit does not meet the specifications recited in the DEMO BOARD manual the kit may be returned within 30 days from the date of delivery for a full refund. **THE FOREGOING WARRANTY IS THE EXCLUSIVE WARRANTY MADE BY THE SELLER TO BUYER AND IS IN LIEU OF ALL OTHER WARRANTIES, EXPRESSED, IMPLIED, OR STATUTORY, INCLUDING ANY WARRANTY OF MERCHANTABILITY OR FITNESS FOR ANY PARTICULAR PURPOSE. EXCEPT TO THE EXTENT OF THIS INDEMNITY, NEITHER PARTY SHALL BE LIABLE TO THE OTHER FOR ANY INDIRECT, SPECIAL, INCIDENTAL, OR CONSEQUENTIAL DAMAGES.**

The user assumes all responsibility and liability for proper and safe handling of the goods. Further, the user releases LTC from all claims arising from the handling or use of the goods. Due to the open construction of the product, it is the user's responsibility to take any and all appropriate precautions with regard to electrostatic discharge. Also be aware that the products herein may not be regulatory compliant or agency certified (FCC, UL, CE, etc.).

No License is granted under any patent right or other intellectual property whatsoever. **LTC assumes no liability for applications assistance, customer product design, software performance, or infringement of patents or any other intellectual property rights of any kind.**

LTC currently services a variety of customers for products around the world, and therefore this transaction **is not exclusive**.

**Please read the DEMO BOARD manual prior to handling the product.** Persons handling this product must have electronics training and observe good laboratory practice standards. **Common sense is encouraged.**

This notice contains important safety information about temperatures and voltages. For further safety concerns, please contact a LTC application engineer.

Mailing Address:

Linear Technology  
1630 McCarthy Blvd.  
Milpitas, CA 95035

Copyright © 2004, Linear Technology Corporation



Компания «ЭлектроПласт» предлагает заключение долгосрочных отношений при поставках импортных электронных компонентов на взаимовыгодных условиях!

Наши преимущества:

- Оперативные поставки широкого спектра электронных компонентов отечественного и импортного производства напрямую от производителей и с крупнейших мировых складов;
- Поставка более 17-ти миллионов наименований электронных компонентов;
- Поставка сложных, дефицитных, либо снятых с производства позиций;
- Оперативные сроки поставки под заказ (от 5 рабочих дней);
- Экспресс доставка в любую точку России;
- Техническая поддержка проекта, помощь в подборе аналогов, поставка прототипов;
- Система менеджмента качества сертифицирована по Международному стандарту ISO 9001;
- Лицензия ФСБ на осуществление работ с использованием сведений, составляющих государственную тайну;
- Поставка специализированных компонентов (Xilinx, Altera, Analog Devices, Intersil, Interpoint, Microsemi, Aeroflex, Peregrine, Syfer, Eurofarad, Texas Instrument, Miteq, Cobham, E2V, MA-COM, Hittite, Mini-Circuits, General Dynamics и др.);

Помимо этого, одним из направлений компании «ЭлектроПласт» является направление «Источники питания». Мы предлагаем Вам помощь Конструкторского отдела:

- Подбор оптимального решения, техническое обоснование при выборе компонента;
- Подбор аналогов;
- Консультации по применению компонента;
- Поставка образцов и прототипов;
- Техническая поддержка проекта;
- Защита от снятия компонента с производства.



#### Как с нами связаться

**Телефон:** 8 (812) 309 58 32 (многоканальный)

**Факс:** 8 (812) 320-02-42

**Электронная почта:** [org@eplast1.ru](mailto:org@eplast1.ru)

**Адрес:** 198099, г. Санкт-Петербург, ул. Калинина, дом 2, корпус 4, литера А.