

Product Specification

SFP+ Bail and Latch Assembly

PRODUCT FEATURES

- US patent # 7,351,090
- Bail and latch for SFP+ applications
- Various Bail Color options:
 - Black
 - Blue
 - White
 - Orange
 - Beige
 - Red
 - Brown
 - Green
 - Grey

These parts are designed to provide the latching and release mechanism for pluggable SFP+ modules.

Advanced Optical Components, a division of Finisar Corp., offers the bail and the latch as piece parts for external sale to module manufacturers for use within their particular modules. The bail is available in various colors.

This datasheet provides the mechanical dimensions of the bail and the latch, the material information for the bail and the latch as well as interface directions.

PRODUCT SELECTION

Part Number	Description
FTA-BL-SFP+/BLK	BAIL, LF, SFP+, SHEET METAL BASED, BLACK
FTA-BL-SFP+/BLU	BAIL, LF, SFP+, SHEET METAL BASED, BLUE
FTA-BL-SFP+/BGE	BAIL, LF, SFP+, SHEET METAL BASED, BEIGE
FTA-BL-SFP+/ORG	BAIL, LF, SFP+, SHEET METAL BASED, ORANGE
FTA-BL-SFP+/WHT	BAIL, LF, SFP+, SHEET METAL BASED, WHITE
FTA-BL-SFP+/RED	BAIL, LF, SFP+, SHEET METAL BASED, RED
FTA-BL-SFP+/BRW	BAIL, LF, SFP+, SHEET METAL BASED, BROWN
FTA-BL-SFP+/GRN	BAIL, LF, SFP+, SHEET METAL BASED, GREEN
FTA-BL-SFP+/GRY	BAIL, LF, SFP+, SHEET METAL BASED, GREY
FTA-BL-SFP+/YLO	BAIL, LF, SFP+, SHEET METAL BASED, YELLOW
FTA-LT-SFP+	LATCH, SFP+

SFP+ Bail Assembly



SFP+ Latch Assembly



- NOTE: UNLESS OTHERWISE SPECIFIED
 1. MATERIAL: ZINC ALLOY NO.3 PER ASTM B84-88.
 2. FINISH:
 2.1 N PLATE
 2.2 CU UNDERPLATE REQUIRED OVER BASE MATERIAL.
 2.3 ALL DIMENSIONS APPLY AFTER PLATING. PLATING THICKNESS INSPECTION POINTS ARE IDENTIFIED WITH A TRIANGLE.
 3. ALL INTERNAL RADIUS SHALL BE 0.13mm MAX. CORNER RADIUS SHALL BE 0.13mm MAX.
 4. MAX DRAFT SHALL BE 1°. ALL DRAFT SHALL BE APPLIED SUCH THAT THE LIMITS OF SIZE NOTED ARE HELD AT THE SURFACES INDICATED.
 5. GATES AND EJECTORS:
 6.1 EJECTOR MARKS SHALL NOT CAUSE ANY FEATURE TO BE OUT OF ITS SPECIFIED LIMITS OF SIZE OR LOCATION.
 6.2 STA INTERSECTING LINE FLASH AND GATE VESTIGE TO BE 0.05mm HIGH MAX.
 7. CRITICAL SURFACE DIMENSIONS OR PARAMETERS.
 8.1 CRITICAL TO FUNCTION DIMENSIONS ARE IDENTIFIED WITH AN INSPECTION BUBBLE.

UNLESS OTHERWISE SPECIFIED:
 DIMENSIONS ARE IN MILLIMETERS
 TOLERANCES ARE:
 .XX ± .2
 .XXX ± .10
 .XXXX ± .050
 .XXXXX ± .0250
 ANGLES ± 1 DEG.

SFP+ Shell Geometr

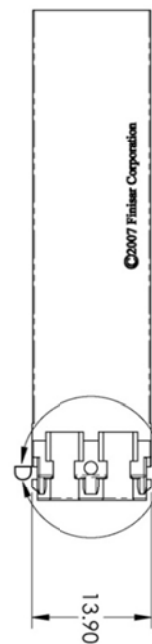
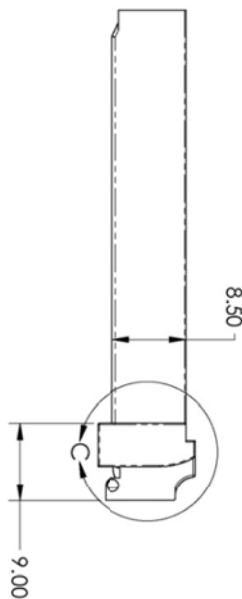
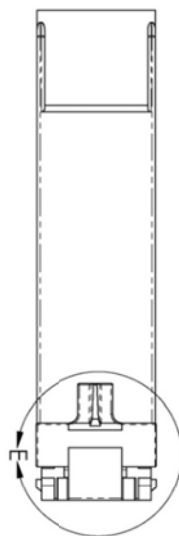
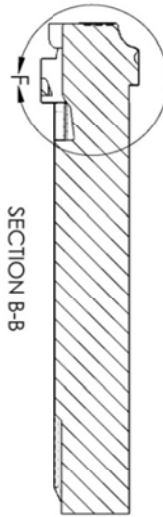

- NOTE: UNLESS OTHERWISE SPECIFIED
 1. MATERIAL: ZINC ALLOY (NO.3 PER ASTM B86-88).
 2. FINISH:
 2.1. Ni PLATE
 2.2. CU UNDERPLATE REQUIRED OVER BASE MATERIAL.
 2.3. ALL DIMENSIONS APPLY AFTER PLATING. PLATING THICKNESS INSPECTION POINTS ARE IDENTIFIED WITH A TRIANGLE.
 3. ALL INTERNAL RADII SHALL BE 0.13mm MAX. CORNER RADII SHALL BE 0.13mm MAX.
 4. MAX DRAFT SHALL BE 1°. ALL DRAFT SHALL BE APPLIED SUCH THAT THE LIMITS OF SIZE NOTED ARE HELD AT THE SURFACES INDICATED.
 6. GATES AND EJECTORS:
 6.1 EJECTOR MARKS SHALL NOT CAUSE ANY FEATURE TO BE OUT OF ITS SPECIFIED LIMITS OF SIZE OR LOCATION.
 6.2 STANDING PARTING LINE FLASH AND GATE VESTAGE TO BE 0.05mm HIGH MAX.
 7. CRITICAL INTERFACE DIMENSIONS OR PARAMETERS.
 8.1 CRITICAL TO FUNCTION DIMENSIONS ARE IDENTIFIED WITH AN INSPECTION BUBBLE.

SFP+ Bail Shell Geometry

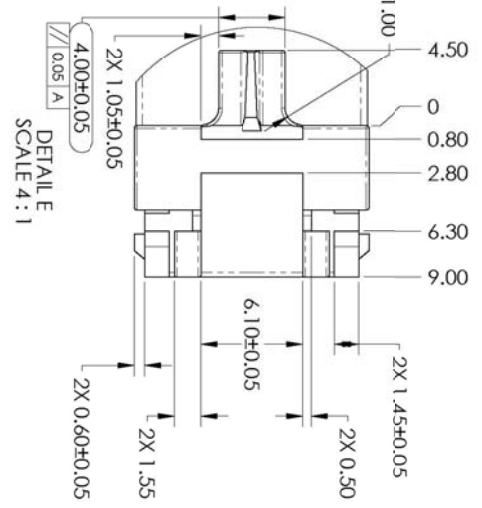
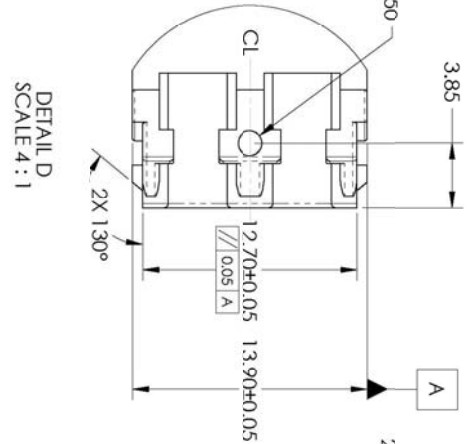
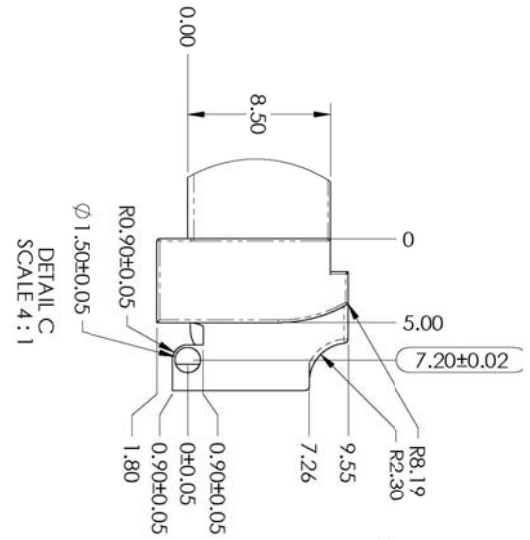
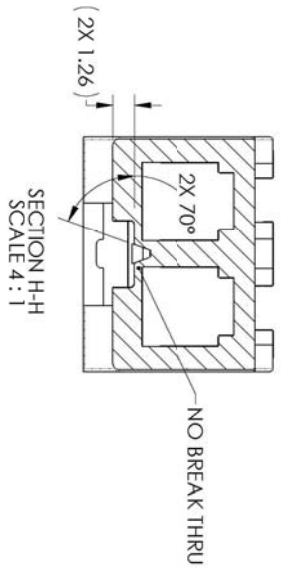
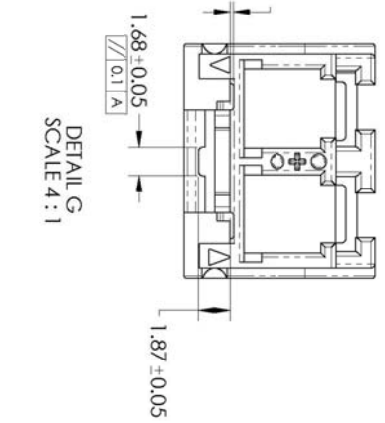

SFP+ BAIL – SHEET METAL



SFP+ BAIL – PAINT TRANSFER DECAL

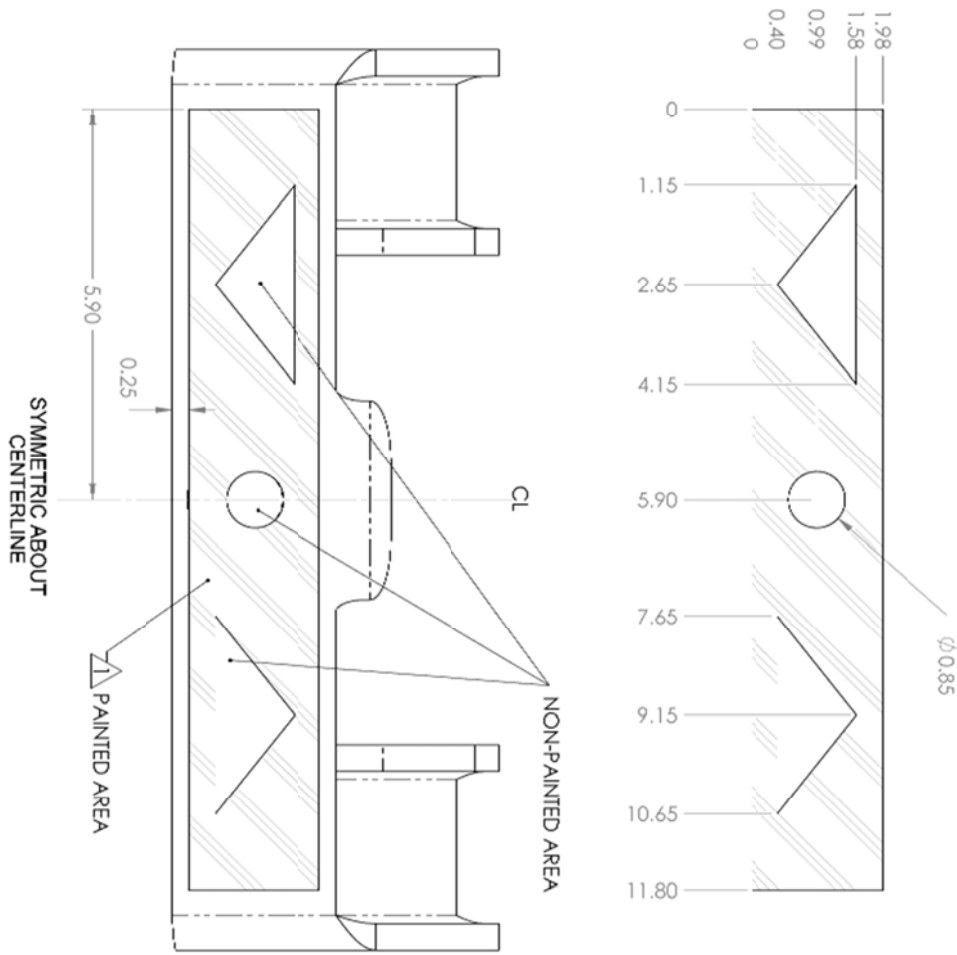

NOTES:
 /A SURFACE MUST BE FREE FROM SCRATCHES, DERRIS, AND OTHER CONTAMINANTS.

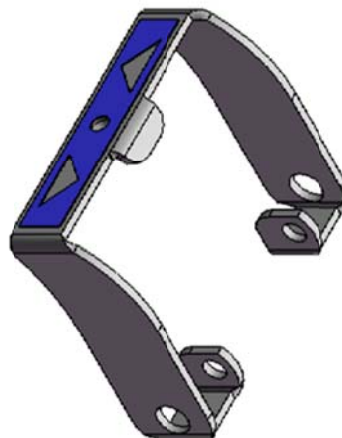

Assembly Instructions



Revision History

Revision	Date	Description
N	4/13/2013	• Finisar Datasheet format

XII. For More Information

Finisar Corporation
1389 Moffett Park Drive
Sunnyvale, CA 94089-1133
Tel. 1-408-548-1000
Fax 1-408-541-6138
sales@finisar.com
www.finisar.com



Компания «ЭлектроПласт» предлагает заключение долгосрочных отношений при поставках импортных электронных компонентов на взаимовыгодных условиях!

Наши преимущества:

- Оперативные поставки широкого спектра электронных компонентов отечественного и импортного производства напрямую от производителей и с крупнейших мировых складов;
- Поставка более 17-ти миллионов наименований электронных компонентов;
- Поставка сложных, дефицитных, либо снятых с производства позиций;
- Оперативные сроки поставки под заказ (от 5 рабочих дней);
- Экспресс доставка в любую точку России;
- Техническая поддержка проекта, помощь в подборе аналогов, поставка прототипов;
- Система менеджмента качества сертифицирована по Международному стандарту ISO 9001;
- Лицензия ФСБ на осуществление работ с использованием сведений, составляющих государственную тайну;
- Поставка специализированных компонентов (Xilinx, Altera, Analog Devices, Intersil, Interpoint, Microsemi, Aeroflex, Peregrine, Syfer, Eurofarad, Texas Instrument, Miteq, Cobham, E2V, MA-COM, Hittite, Mini-Circuits, General Dynamics и др.);

Помимо этого, одним из направлений компании «ЭлектроПласт» является направление «Источники питания». Мы предлагаем Вам помощь Конструкторского отдела:

- Подбор оптимального решения, техническое обоснование при выборе компонента;
- Подбор аналогов;
- Консультации по применению компонента;
- Поставка образцов и прототипов;
- Техническая поддержка проекта;
- Защита от снятия компонента с производства.



Как с нами связаться

Телефон: 8 (812) 309 58 32 (многоканальный)

Факс: 8 (812) 320-02-42

Электронная почта: org@eplast1.ru

Адрес: 198099, г. Санкт-Петербург, ул. Калинина, дом 2, корпус 4, литера А.