

ZXSC400

LED DRIVER BOOST CONVERTER

DESCRIPTION

The ZXSC400 is a voltage mode boost converter in the SOT23-6 package. Its low feedback voltage allows the current in a chain of LEDs to be set and accurately monitored with a single resistor giving minimal losses. Its excellent load and line regulation means that for the full supply range from lithium-ion cells, the LED current will typically change by less than 1%. Using high efficiency Zetex switching transistors with ratings of 20V and higher allow many LEDs to be chained in series for the best LED current matching possible.

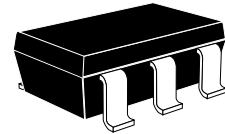

SOT23-6

FEATURES

- 1.8V to 8V supply range
- Typical output regulation of $\pm 1\%$
- Over 80% typical efficiency
- 4.5 μ A typical shutdown current
- Series connection for ultimate LED current matching

APPLICATIONS

- White LED backlighting for colour LCD panels
- General LED backlighting
- High performance white LED flashlights
- General LED driving from batteries

PINOUT

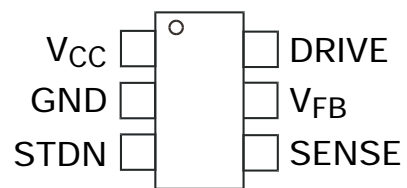

Top View

ORDERING INFORMATION

DEVICE	REEL SIZE	TAPE WIDTH	QUANTITY PER REEL
ZXSC400E6TA	7"	8mm	3000 units

DEVICE MARKING

- C400

ZXSC400

ABSOLUTE MAXIMUM RATINGS

V _{CC}	-0.3V to +10V
DRIVE	-0.3V to V _{CC} + 0.3V
EOR	-0.3V to V _{CC} + 0.3V
STDN	-0.3V to The lower of (+5.0V) or (V _{CC} + 0.3V)
SENSE	-0.3V to The lower of (+5.0V) or (V _{CC} + 0.3V)
Operating Temp.	-40°C to +85°C
Storage Temp.	-55°C to +125°C
Power Dissipation	450mW

ELECTRICAL CHARACTERISTICS

Test Conditions V_{CC} = 3V, T = -40°C to 85°C unless otherwise stated.

Symbol	Parameter	Conditions	Limits			Units
			Min	Typ	Max	
Supply parameters						
V _{IN}	V _{CC} Range		1.8		8	V
I _q ¹	Quiescent Current	V _{CC} = 8V			220	μA
I _{STDN}	Shutdown Current			4.5		μA
Eff ¹	Efficiency	30mA > I _{LED} > 10mA		80		%
Acc _{REF}	Reference tolerance	1.8V < V _{CC} < 8V	-3.0		3.0	%
TCO _{REF}	Reference Temp Co			0.005		%/°C
T _{DRIVE}	Discharge pulse width	1.8V < V _{CC} < 8V		1.7		μs
F _{OSC}	Operating Frequency				200	kHz
Input parameters						
V _{SENSE}	Sense voltage		22	28	34	mV
I _{SENSE}	Sense input current	V _{FB} = 0V, V _{SENSE} = 0V	-1	-7	-15	μA
V _{FB}	Feedback voltage		291	300	309	mV
I _{FB} ²	Feedback input current	V _{FB} = 0V, V _{SENSE} = 0V	-1.2		-4.5	μA
V _{IH}	Shutdown high voltage		1.5		V _{CC}	V
V _{IL}	Shutdown low voltage		0		0.55	V
dV _{LN}	Line voltage regulation			0.5		%/V
Output parameters						
I _{OUT} ³	Output current	V _{in} > 2V, V _{out} = 10.5V	50			mA
I _{DRIVE}	Transistor drive current	V _{drive} = 0.7V	2	3.5	5	mA
V _{DRIVE}	Transistor voltage drive	1.8V < V _{CC} < 8V	0		V _{CC} -0.4	V
C _{DRIVE}	Mosfet gate drive cpbty			300		pF
dILD ⁴	Load current regulation				0.1	mA/V

Note

¹ Excluding gate/base drive current.

² I_{FB} is typically half these values at 300mV.

³ System not device spec, including recommended transistors. 10.5V represents 3 white LEDs.

⁴ Change in LED current with changing supply voltage (LED V_F x number of series LEDs).



ISSUE 1 - JANUARY 2003

ZXSC400

TYPICAL CHARACTERISTICS

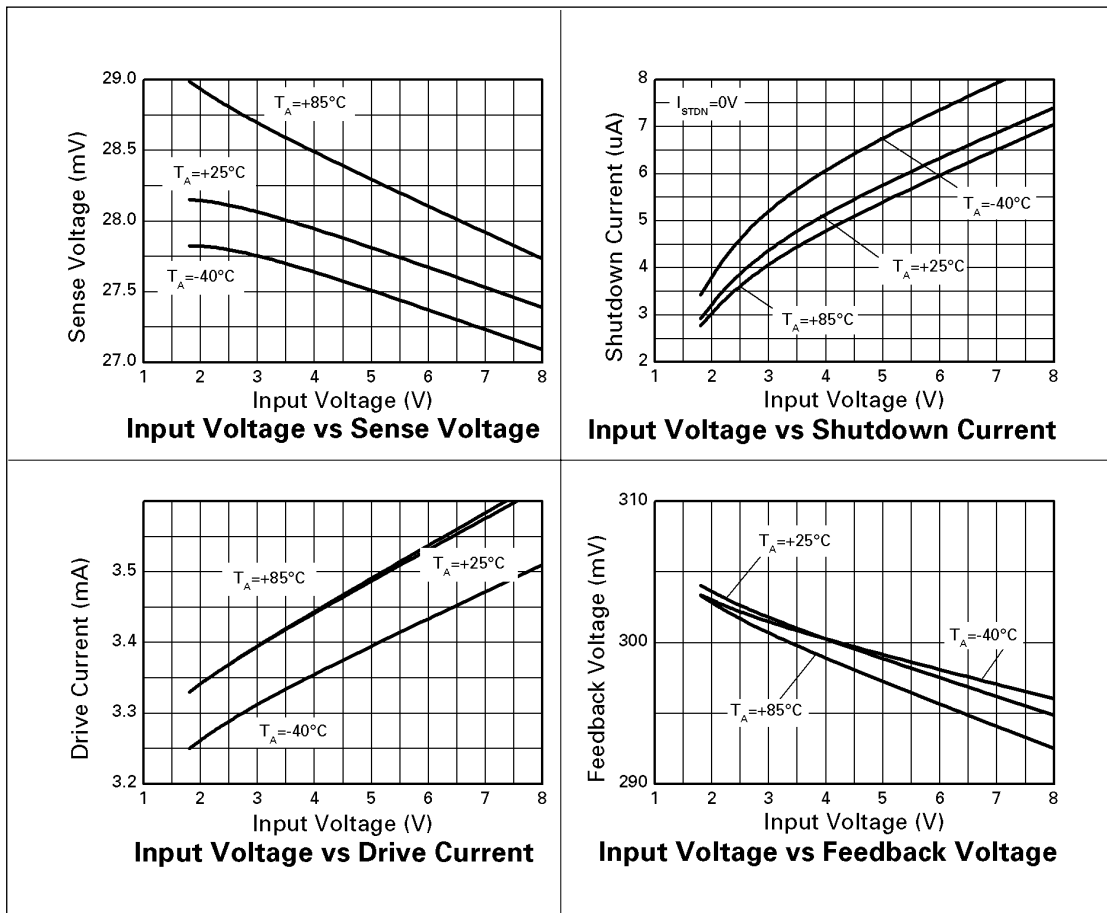

ZXSC400

DESIGN INFORMATION

IC operation description

Bandgap Reference

All threshold voltages and internal currents are derived from a temperature compensated bandgap reference circuit with a reference voltage of 1.22V nominal.

Dynamic Drive Output

Depending on the input signal, the output is either "LOW" or "HIGH". In the high state a 2.5mA current source (max drive voltage = $V_{CC}-0.4V$) drives the base or gate of the external transistor. In order to operate the external switching transistor at optimum efficiency, both output states are initiated with a short transient current in order to quickly discharge the base or the gate of the switching transistor.

Switching Circuit

The switching circuit consists of two comparators, Comp1 and Comp2, a gate U1, a monostable and the drive output. Normally the DRIVE output is "HIGH"; the external switching transistor is turned on. Current ramps up in the inductor, the switching transistor and external current sensing resistor. This voltage is sensed by comparator, Comp2, at input I_{SENSE} . Once the current sense voltage across the sensing resistor exceeds 30mV, comparator Comp2 through gate U1 triggers a re-triggerable monostable and turns off the output drive stage for 2 μ s. The inductor discharges to the load of the application. After 2 μ s a new charge cycle begins, thus ramping the output voltage. When the output voltage reaches the nominal value and FB gets an input voltage of more than 300mV, the monostable is forced "on" from Comp1 through gate U1, until the feedback voltage falls below 300mV. The above action continues to maintain regulation.

Block diagram

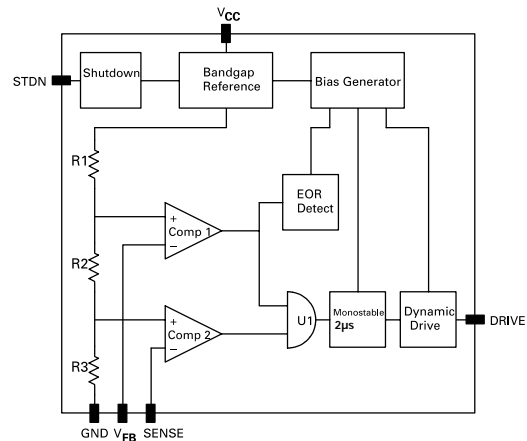

Pin functions

Pin No.	Name	Description
1	V_{CC}	Supply voltage, 1.8V to 8V.
2	GND	Ground
3	STDN	Shutdown
4	SENSE	Inductor current sense input. Internal threshold voltage set to 30mV. Connect external sense resistor
5	V_{FB}	Reference voltage. Internal threshold set to 300mV. Connect external resistor to program LED current
6	DRIVE	Drive output for external switching transistor. Connect to base or gate of external switching transistor.

ZXSC400

APPLICATIONS INFORMATION

Switching transistor selection

The choice of switching transistor has a major impact on the converter efficiency. For optimum performance, a bipolar transistor with low $V_{CE(SAT)}$ and high gain is required. The V_{CEO} of the switching transistor is also an important parameter as this sees the full output voltage when the transistor is switched off. Zetex SuperSOT™ transistors are an ideal choice for this application.

Schottky diode selection

As with the switching transistor, the Schottky rectifier diode has a major impact on the converter efficiency. A Schottky diode with a low forward voltage and fast recovery time should be used for this application.

The diode should be selected so that the maximum forward current rating is greater or equal to the maximum peak current in the inductor, and the maximum reverse voltage is greater or equal to the output voltage. The Zetex ZHCS Series meet these needs.

Combination devices

To minimise the external component count Zetex recommends the ZX3CDBS1M832 combination of NPN transistor and Schottky diode in a 3mm x 2mm MLP package. This device is recommended for use in applications using 1 to 4 white LEDs.

The IC is also capable of driving MOSFETs. Zetex recommends the ZXMNS3BM832 combination of low threshold voltage N-Channel MOSFET and Schottky diode in a 3mm x 2mm MLP package. This device is recommended for use in applications using 1 to 8 white LEDs.

Capacitor Selection

A small value, low ESR ceramic capacitor is required to filter the output, typically 1 μ F to 4.7 μ F.

Generally an input capacitor is not required, but a small ceramic capacitor may be added to aid EMC, typically 1 μ F to 4.7 μ F.

Inductor Selection

The inductor value must be chosen to satisfy performance, cost and size requirements of the overall solution.

Inductor selection has a significant impact on the converter performance. For applications where efficiency is critical, an inductor with a series resistance of 250m Ω or less should be used.

A list of recommended inductors is listed in the table below:

Part No.	Manufacture	L	I _{PK} (A)	R _{DC} (Ω)
CMD4D11-100MC	Sumida	10 μ H	0.5	0.457
CMD4D11-220MC	Sumida	22 μ H	0.4	0.676
LPO2506OB-103	Coilcraft	10 μ H	1.0	0.24
ST2006103	Standex Electronics Inc	10 μ H	0.6	0.1

ZXSC400

Peak current definition

In general, the I_{PK} value must be chosen to ensure that the switching transistor, Q1, is in full saturation with maximum output power conditions, assuming worst-case input voltage and transistor gain under all operating temperature extremes.

Once I_{PK} is decided the value of R_{SENSE} can be determined by:

$$R_{SENSE} = \frac{V_{SENSE}}{I_{PK}}$$

Sense Resistor

A low value sense resistor is required to set the peak current. Power in this resistor is negligible due to the low sense voltage threshold, V_{ISENSE} . At the bottom of the page there is a table of recommended sense resistors.

Output power calculation

By making the above assumptions for inductance and peak current the output power can be determined by:

$$P_{OUT} = I_{AV} \times V_{IN} \times \eta \text{ (Watts)}$$

where

$$I_{AV} = \frac{I_{PK}}{2} \times \frac{(T_{ON} + T_{DIS})}{(T_{ON} + T_{OFF})}$$

and

$$T_{ON} = \frac{I_{PK} \times L}{V_{IN}}$$

and

$$T_{DIS} = \frac{I_{PK} \times L}{(V_{LED} - V_{IN})}$$

and

$$T_{OFF} \cong 1.7\mu\text{s (internally set by ZXSC400)}$$

and

$$\eta = \text{efficiency e.g. } 100\% = 1$$

Operating frequency can be derived by:

$$F = \frac{1}{T_{ON} + T_{OFF}}$$

Programming LED current

Once the required output power is determined, the LED current can be programmed by adding a single resistor in the LED chain. The resistor value is determined by the following:

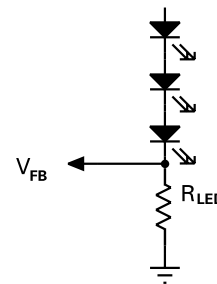

$$I_{LED} = \frac{V_{FB}}{R_{LED}}$$

Where $V_{FB} = 300\text{mV}$

R_{LED} selection table

I_{LED}	R_{LED}
40mA	7.5Ω
30mA	10Ω
20mA	15Ω
15mA	20Ω
10mA	30Ω

Shutdown Control

The ZXSC400 offers a shutdown mode that consumes a standby current of less than $5\mu\text{A}$. When the voltage at the S_{TDN} pin between 1V and 8V (and also open circuit), the ZXSC400 is enabled and the driver is in normal operation. When the voltage at the $STDN$ pin is 0.7V or lower, the ZXSC400 is disabled and the driver is in shutdown mode. The $SHDN$ input is a high impedance current source of $1\mu\text{A}$ typ. The driving device can be an open collector or an open drain or a logic output with a "High" voltage of 5V max. The device shutdown current depends of the supply voltage, see typical characteristics graph

Manufacture	Series	$R_{DC}(\Omega)$ Range	Size	Tolerance	URL
Cyntec	RL1220	0.022 - 10	0805	±5%	www.cyntec.com
IRC	LR1206	0.010 - 1.0	1206	±5%	www.irctt.com



ISSUE 1 - JANUARY 2003

ZXSC400

Open-circuit protection

For applications where the LED chain might go open-circuit a Zener diode can be connected across the LED chain preventing over-voltage and possible damage to the main switching transistor. The Zener diodes should be selected by ensuring its voltage rating is higher than the combined forward voltage of the LED chain. Under open circuit conditions the current in the Zener diode defines the output current as:

$$I_z = \frac{V_{FB}}{R_z}$$

The circuit example below give an open circuit output current of 300µA.

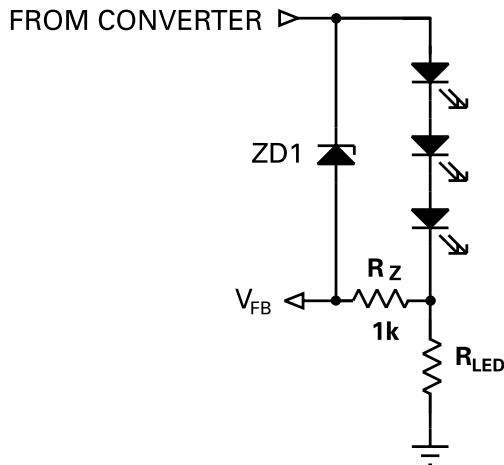

Dimming Control using the shutdown pin

The first method uses the shutdown pin. By injecting a PWM waveform on this pin and varying the duty cycle, LED current and hence LED brightness can be adjusted.

To implement this method of brightness control on the ZXSC400, apply PWM signal with amplitude of between 0.7V and Vcc at a frequency of 120Hz or above (to eliminate LED flicker). The LED current and hence LED brightness is linearly proportional to the duty cycle ratio, so for brightness control adjust duty cycle ratio as necessary. For example, a 10% duty cycle equates to 10% of full LED brightness.

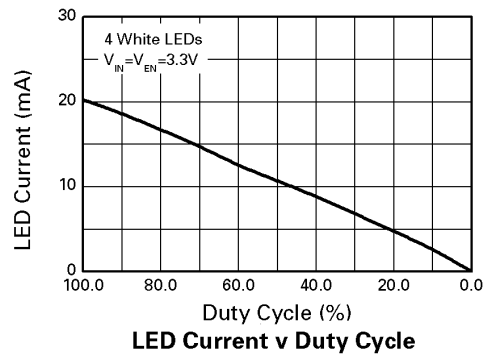

Dimming Control

There are four types of dimming control that can be implemented for the ZXSC400.

ZXSC400

Dimming Control using a DC voltage

For applications where the shutdown pin is not available a DC voltage can be used to control dimming. By adding resistors R2 and R3 and applying a DC voltage, the LED current can be adjusted from 100% to 0%. As the DC voltage increases, the voltage drop across R2 increases and the voltage drop across R1 decreases, thus reducing the current through the LEDs. Selection of R2 and R3 should ensure that the current from the DC voltage is much less than the LED current and much larger than the feedback current. The component values in the diagram below represent 0% to 100% dimming control from a 0 to 2V DC voltage.

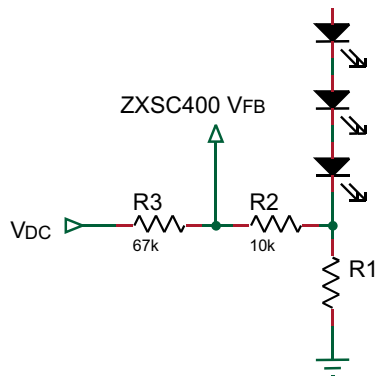

Dimming Control using a filtered PWM signal

The filtered PWM signal can be considered as an adjustable DC voltage by applying a RC filter. The values shown in the diagram below are configured to give 0% to 100% dimming for a 1kHz to 100kHz PWM signal with a 2V amplitude. e.g. a 50% duty cycle will give 50% dimming.

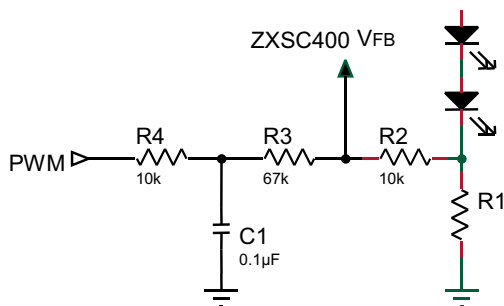

Dimming Control using a logic signal

For applications where the LED current needs to be adjusted in discrete steps a logic signal can be applied as shown in the diagram below. When Q1 is 'off', R1 sets the minimum LED current. When Q1 is 'on', R2 sets the LED current that will be added to the minimum LED current. The formula for selecting values for R1 and R2 are given below:

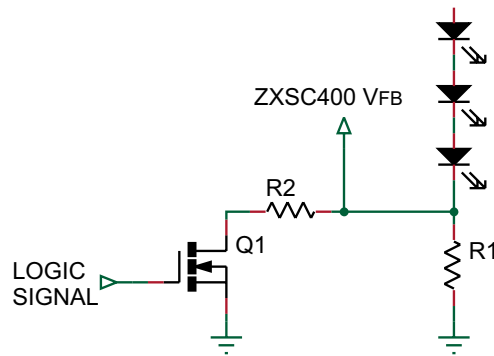

MOSFET 'off'

$$I_{LED(MIN)} = \frac{V_{FB}}{R_{LEB}}$$

MOSFET 'on'

$$I_{LED(MAX)} = \frac{V_{FLB}}{R_{LEB}} + I_{LED(MIN)}$$

Where $V_{FB} = 300mV$

ZXSC400

Layout considerations

Layout is critical for the circuit to function in the most efficient manner in terms of electrical efficiency, thermal considerations and noise.

For 'step-up converters' there are four main current loops, the input loop, power-switch loop, rectifier loop and output loop. The supply charging the input capacitor forms the input loop. The power-switch loop is defined when Q1 is 'on', current flows from the input through the inductor, Q1, R_{SENSE} and to ground. When Q1 is 'off', the energy stored in the inductor is transferred to the output capacitor and load via D1, forming the rectifier loop. The output loop is formed by the output capacitor supplying the load when Q1 is switched back off.

To optimise for best performance each of these loops kept separate from each other and interconnected with short, thick traces thus minimising parasitic inductance, capacitance and resistance. Also the R_{SENSE} resistor should be connected, with minimum trace length, between emitter lead of Q1 and ground, again minimising stray parasitics.

ZXSC400

REFERENCE DESIGNS

Li - Ion to 2 LED converter

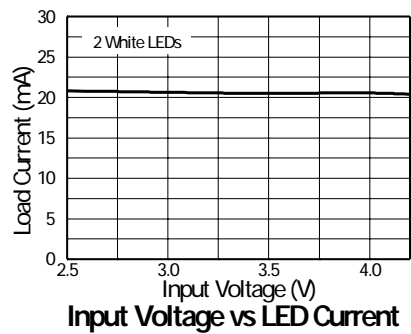
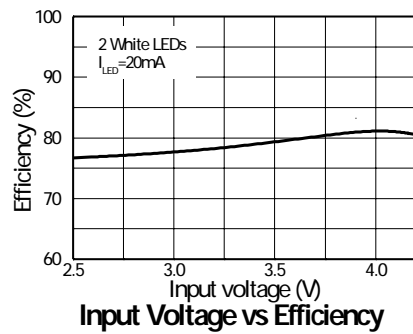
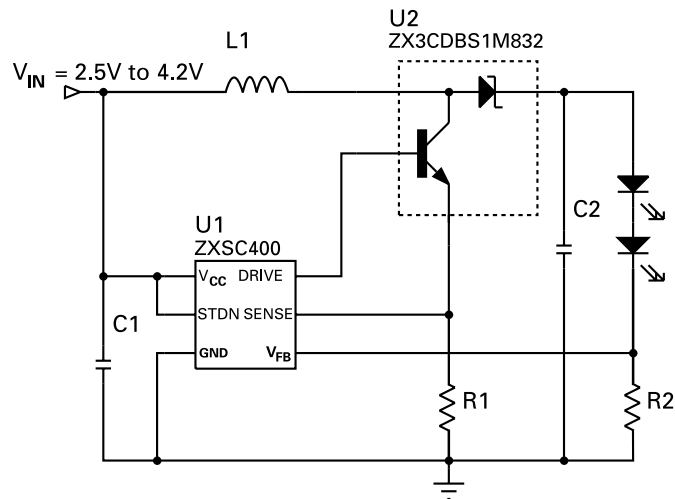

Bill of Materials

Ref	Value	Part Number	Manufacture	Comments
U1		ZXSC400	Zetex	LED driver IC
U2		ZX3CDBS1M832	Zetex	NPN + Schottky dual
L1	10 μ H	CMD4D11-100MC	Sumida	1mm height profile
R1	100m Ω	LR1206 / RL1220	IRC / Cyntec	1206 / 0805 size
R2	15 Ω	Generic	Generic	0603 size
C1	2.2 μ F/6V3	GRM Series	Murata	0805 size
C2	2.2 μ F/16V	GRM Series	Murata	1206 size
LED		NSCW215	Nichia	White SMT LED



ISSUE 1 - JANUARY 2003

ZXSC400

Li - Ion to 3 LED converter

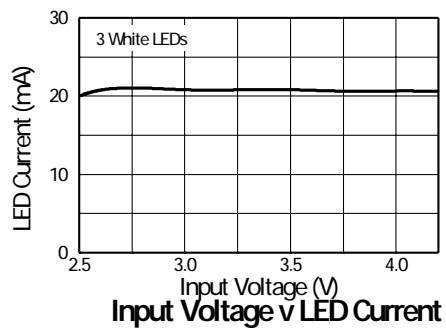
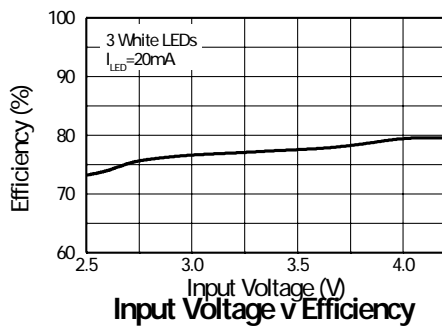
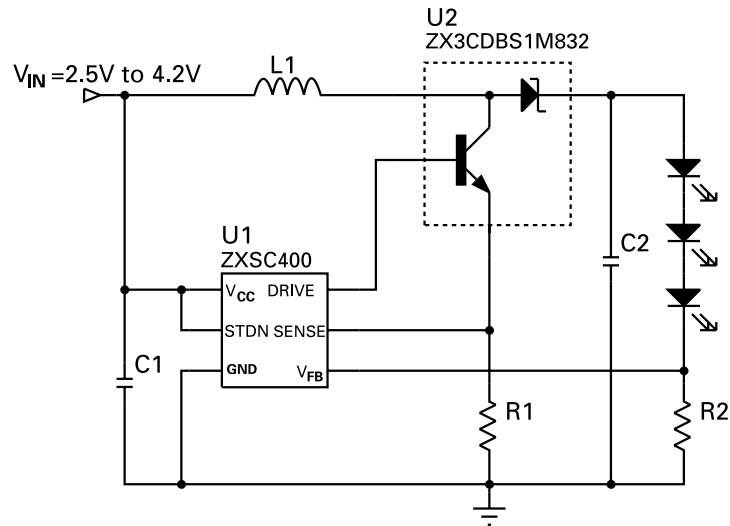

Bill of Materials

Ref	Value	Part Number	Manufacture	Comments
U1		ZXSC400	Zetex	LED driver IC
U2		ZX3CDBS1M832	Zetex	NPN + Schottky dual
L1	10 μ H	CMD4D11-100MC	Sumida	1mm height profile
R1	68m Ω	LR1206 / RL1220	IRC / Cyntec	1206 / 0805 size
R2	15 Ω	Generic	Generic	0603 size
C1	2.2 μ F/6V3	GRM Series	Murata	0805 size
C2	2.2 μ F/16V	GRM Series	Murata	1206 size
LED		NSCW215	Nichia	White SMT LED

ISSUE 1 - JANUARY 2003



ZXSC400

Li - Ion to 4 LED converter

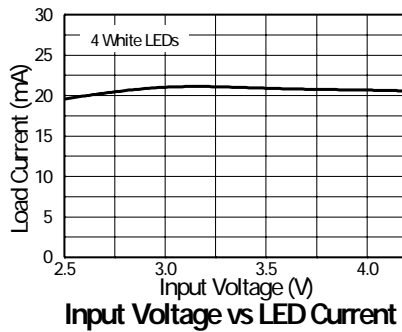
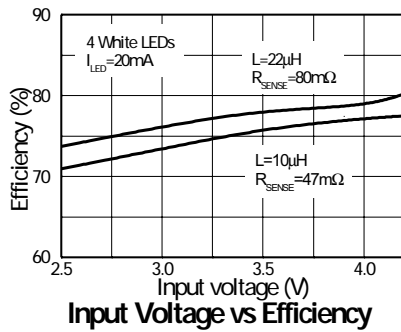
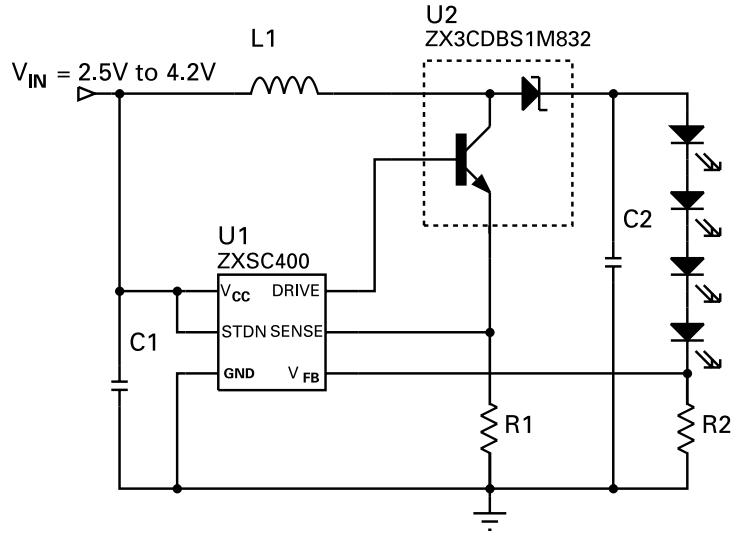

Bill of Materials

Ref	Value	Part Number	Manufacture	Comments
U1		ZXSC400	Zetex	LED driver IC
U2		ZX3CDBS1M832	Zetex	NPN + Schottky dual
L1	10 μH	CMD4D11-100MC	Sumida	1mm height profile
R1	47m Ω	LR1206 / RL1220	IRC / Cyntec	1206 / 0805 size
R2	15 Ω	Generic	Generic	0603 size
C1	2.2 $\mu\text{F}/6\text{V}3$	GRM Series	Murata	0805 size
C2	2.2 $\mu\text{F}/16\text{V}$	GRM Series	Murata	1206 size
LED		NSCW215	Nichia	White SMT LED

ZXSC400

Li - Ion to 6 LED converter

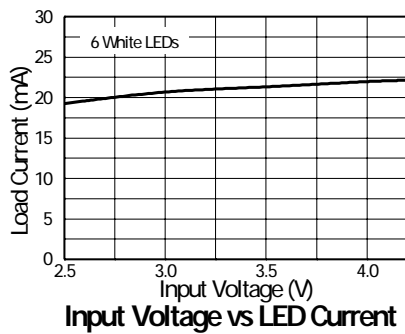
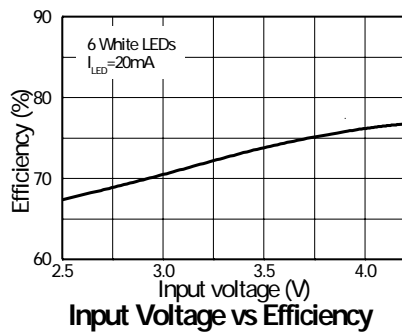
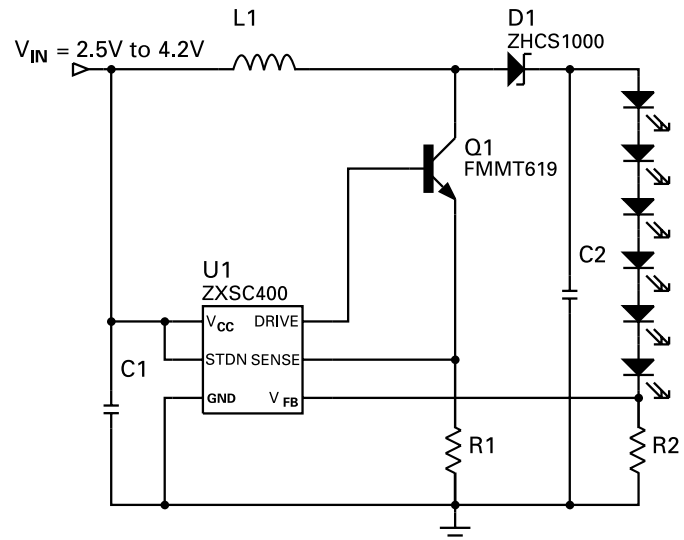

Bill of Materials

Ref	Value	Part Number	Manufacture	Comments
U1		ZXSC400	Zetex	LED driver IC
Q1		FMMT619	Zetex	40V NPN
D1		ZHCS1000	Zetex	1A Schottky diode
L1	22 μ H	CMD4D11-220MC	Sumida	1mm height profile
R1	47m Ω	LR1206 / RL1220	IRC / Cyntec	1206 / 0805 size
R2	15 Ω	Generic	Generic	0603 size
C1	2.2 μ F/6V3	GRM Series	Murata	0805 size
C2	2.2 μ F/25V	GRM Series	Murata	1206 size
LED		NSCW215	Nichia	White SMT LED

ISSUE 1 - JANUARY 2003



ZXSC400

Li - Ion to 8 LED converter

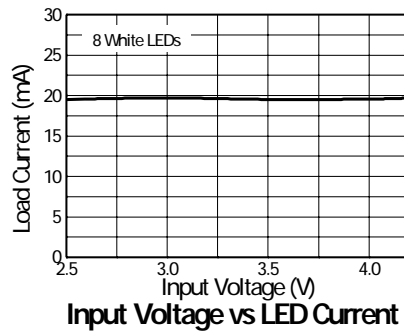
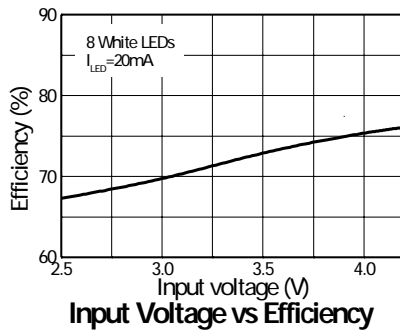
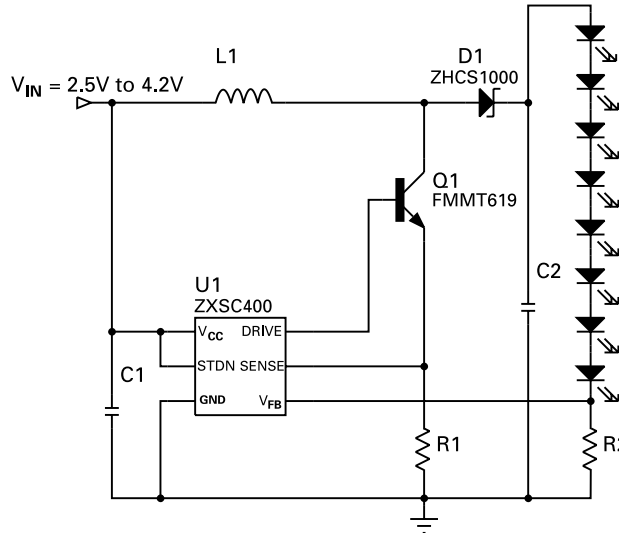

Bill of Materials

Ref	Value	Part Number	Manufacture	Comments
U1		ZXSC400	Zetex	LED driver IC
Q1		FM6T619	Zetex	40V NPN
D1		ZHCS1000	Zetex	1A Schottky diode
L1 or	22 μ H	CDRH4D28-220 D01608C-223	Sumida Coilcraft	0.7A, 0.235 Ω 0.7A, 0.37 Ω
R1	33m Ω	LR1206 / RL1220	IRC / Cynotec	1206 / 0805 size
R2	15 Ω	Generic	Generic	0603 size
C1	2.2 μ F/6V3	GRM Series	Murata	0805 size
C2	2.2 μ F/35V	GRM Series	Murata	1206 size
LED		NSCW215	Nichia	White SMT LED



ISSUE 1 - JANUARY 2003

ZXSC400

Notes

ISSUE 1 - JANUARY 2003

ZXSC400

PACKAGE OUTLINE

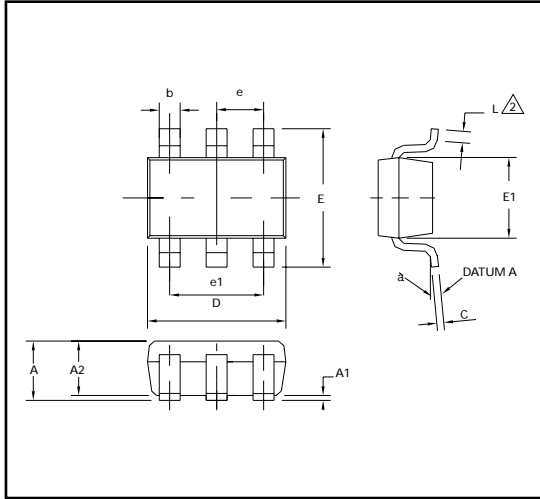

PAD LAYOUT DETAILS

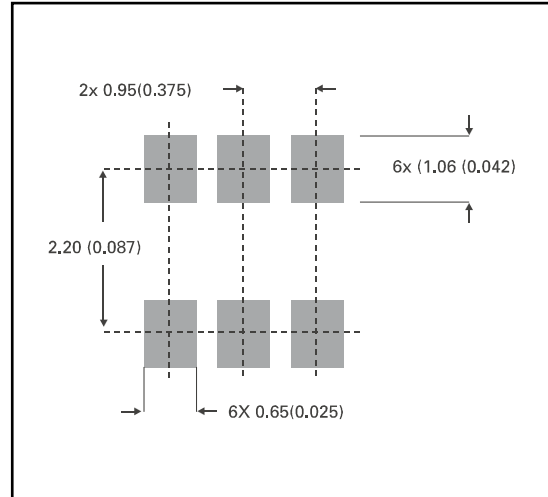

CONTROLLING DIMENSIONS IN MILLIMETRES APPROX CONVERSIONS INCHES.

PACKAGE DIMENSIONS

DIM	Millimetres		Inches		DIM	Millimetres		Inches	
	Min	Max	Min	Max		Min	Max	Min	Max
A	0.90	1.45	0.35	0.057	E	2.60	3.00	0.102	0.118
A1	0.00	0.15	0	0.006	E1	1.50	1.75	0.059	0.069
A2	0.90	1.30	0.035	0.051	L	0.10	0.60	0.004	0.002
b	0.35	0.50	0.014	0.019	e	0.95 REF		0.037 REF	
C	0.09	0.20	0.0035	0.008	e1	1.90 REF		0.074 REF	
D	2.80	3.00	0.110	0.118	L	0°	10°	0°	10°

© Zetex plc 2003

Europe

Zetex plc
Fields New Road
Chadderton
Oldham, OL9 8NP
United Kingdom
Telephone: (44) 161 622 4422
Fax: (44) 161 622 4420
uk.sales@zetex.com

Zetex GmbH
Streitfeldstraße 19
D-81673 München
Germany
Telefon: (49) 89 45 49 49 0
Fax: (49) 89 45 49 49 49
europe.sales@zetex.com

Americas

Zetex Inc
700 Veterans Memorial Hwy
Hauppauge, NY11788
USA
Telephone: (631) 360 2222
Fax: (631) 360 8222
usa.sales@zetex.com

Asia Pacific

Zetex (Asia) Ltd
3701-04 Metroplaza, Tower 1
Hing Fong Road
Kwai Fong
Hong Kong
Telephone: (852) 26100 611
Fax: (852) 24250 494
asia.sales@zetex.com

These offices are supported by agents and distributors in major countries world-wide.

This publication is issued to provide outline information only which (unless agreed by the Company in writing) may not be used, applied or reproduced for any purpose or form part of any order or contract or be regarded as a representation relating to the products or services concerned. The Company reserves the right to alter without notice the specification, design, price or conditions of supply of any product or service.

For the latest product information, log on to www.zetex.com



ISSUE 1 - JANUARY 2003



Компания «ЭлектроПласт» предлагает заключение долгосрочных отношений при поставках импортных электронных компонентов на взаимовыгодных условиях!

Наши преимущества:

- Оперативные поставки широкого спектра электронных компонентов отечественного и импортного производства напрямую от производителей и с крупнейших мировых складов;
- Поставка более 17-ти миллионов наименований электронных компонентов;
- Поставка сложных, дефицитных, либо снятых с производства позиций;
- Оперативные сроки поставки под заказ (от 5 рабочих дней);
- Экспресс доставка в любую точку России;
- Техническая поддержка проекта, помощь в подборе аналогов, поставка прототипов;
- Система менеджмента качества сертифицирована по Международному стандарту ISO 9001;
- Лицензия ФСБ на осуществление работ с использованием сведений, составляющих государственную тайну;
- Поставка специализированных компонентов (Xilinx, Altera, Analog Devices, Intersil, Interpoint, Microsemi, Aeroflex, Peregrine, Syfer, Eurofarad, Texas Instrument, Miteq, Cobham, E2V, MA-COM, Hittite, Mini-Circuits, General Dynamics и др.);

Помимо этого, одним из направлений компании «ЭлектроПласт» является направление «Источники питания». Мы предлагаем Вам помощь Конструкторского отдела:

- Подбор оптимального решения, техническое обоснование при выборе компонента;
- Подбор аналогов;
- Консультации по применению компонента;
- Поставка образцов и прототипов;
- Техническая поддержка проекта;
- Защита от снятия компонента с производства.



Как с нами связаться

Телефон: 8 (812) 309 58 32 (многоканальный)

Факс: 8 (812) 320-02-42

Электронная почта: org@eplast1.ru

Адрес: 198099, г. Санкт-Петербург, ул. Калинина, дом 2, корпус 4, литера А.