

Power Resistor for Mounting onto a Heatsink Thick Film Technology



FEATURES

- LPS high power: 1100 W
- Wide resistance range: 1 Ω to 1.3 kΩ E24 series
- Non inductive
- Easy mounting
- Low thermal radiation of the case
- Material categorization: For definitions of compliance please see www.vishay.com/doc?99912

RoHS
COMPLIANT

DIMENSIONS in millimeters

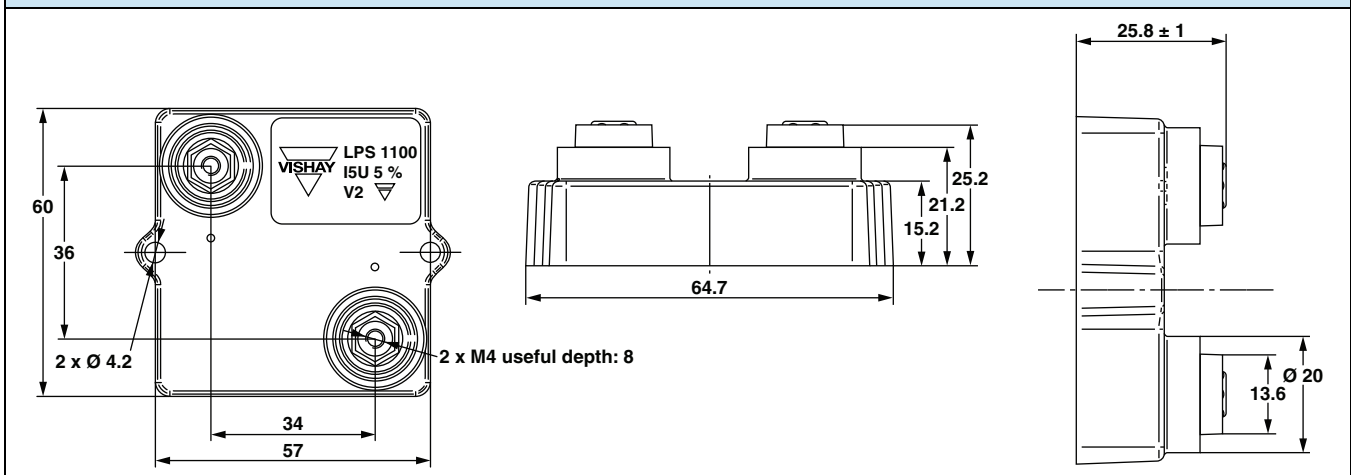

Notes

- Tolerances unless stated: ± 0.2 mm
- Power dissipation is 1100 W by using a water cooled heatsink at $T_{\text{water}} = 15$ °C of $R_{\text{th}} = 0.059$ °C/W (25 °C to the nearest point of the resistor onto heatsink) and R_{th} contact estimated at 0.07 °C/W.

STANDARD ELECTRICAL SPECIFICATIONS

MODEL	RESISTANCE RANGE Ω	RATED POWER $P_{25^\circ\text{C}}$ W	TOLERANCE ± %	TEMPERATURE COEFFICIENT ± ppm/°C
LPS 1100	1 to 1.3K	1100	1, 2, 5, 10	150

MECHANICAL SPECIFICATIONS

Mechanical Protection	Insulated case and resin for potting UL 94 V-0
Resistive Element	Thick film
End Connections	Screws M4
Tightening Torque Connections	2 Nm
Tightening Torque Heatsink	2 Nm
Maximum Torque	2.5 Nm
Weight	79 g ± 10 %

ENVIRONMENTAL SPECIFICATIONS

Temperature Range	- 55 °C to + 200 °C
Climatic Category	55/200/56

TECHNICAL SPECIFICATIONS

Power Rating and Thermal Resistance	1100 W at + 25 °C On heatsink $R_{\text{th(j-c)}}$: 0.039 °C/W
Temperature Coefficient (- 55 °C to + 200 °C), IEC 60115-1	$R \leq 1 \Omega$: ± 500 ppm/°C $1 \Omega < R \leq 10 \Omega$: ± 300 ppm/°C $10 \Omega < R$: ± 150 ppm/°C
Dielectric Strength IEC 60115-1, 1 min, 10 mA max.	7 kV _{RMS} or 12 kV _{RMS}
Insulation	$\geq 10^4$ MΩ
Inductance	≤ 0.1 μH

PERFORMANCE		
TESTS	CONDITIONS	REQUIREMENTS
Momentary Overload	IEC 60115-1: 2 x P _r /10 s for heatsink with R _{th(h-a)} ≥ 0.26 °C/W (maximum power: 700 W) 1.6 x P _r /1 s for heatsink with 0.26 °C/W > R _{th(h-a)} ≥ 0.059 °C/W (maximum power: 1800 W)	± (0.25 % + 0.05 Ω)
Rapid Temperature Change	AEC-Q200 conditions: IEC 60115-1/IEC 60068-2-14, Test Na 50 cycles (- 55 °C to + 200 °C)	± (0.5 % + 0.05 Ω) for all the ohmic values
	1000 cycles (- 55 °C to + 200 °C)	± (5 % + 0.05 Ω) for R < 38 Ω ± (0.5 % + 0.05 Ω) for R ≥ 38 Ω
Load Life	AEC-Q200 conditions: IEC 60115-1 2000 h (90/30) P _r	± (5 % + 0.05 Ω) for R < 38 Ω ± (0.5 % + 0.05 Ω) for R ≥ 38 Ω
Humidity (Steady State)	AEC-Q200 conditions: IEC 60115-1, 1000 h RH 85 %/85 °C	± (0.5 % + 0.05 Ω)
Mechanical Shock	AEC-Q200 conditions: MIL-STD-202 method 213 condition D (100 g's/6 ms 3.75 m/s)	± (1 % + 0.05 Ω)
Vibration	AEC-Q200 conditions: MIL-STD-202 method 204 condition D (5 g, 20 min 10/2000 Hz)	± (1 % + 0.05 Ω)
Climatic Sequence	AEC-Q200 conditions: IEC 60115-1 (55/200/56)	± (1 % + 0.05 Ω)

RECOMMENDATIONS FOR MOUNTING ONTO A HEATSINK

- Surfaces in contact must be carefully cleaned.
- The heatsink must have an acceptable flatness: From 0.05 mm to 0.1 mm/100 mm.
- Roughness of the heatsink must be around 6.3 μm. In order to improve thermal conductivity, surfaces in contact (ceramic, heatsink) should be coated with a silicone grease (type SI 340 from Blue Star Silicones). Thermal film (type Q-pad II from Berquist) is also possible, easier and faster to install than grease but with a lower efficiency for the power dissipation.
- The fastening of the resistor to the heatsink is under pressure control of two screws tightened at 2 Nm for full power availability.

Tightening Torque on Heatsink	LPS 1100
	2 Nm

- The following accessories are supplied with each product:
 - 2 screws CHC M4 x 25 class 8.8 and 2 M4 contact lock washers for heatsink mounting
 - 2 screws TH M4 x 6/6 and 2 M4 contact lock washers for connections. 2 off CHC M4 x 16/16 class 8

CHOICE OF THE HEATSINK AND THE THERMAL INTERFACE

The user must choose the heatsink according to the working conditions of the component (power, room temperature). Maximum working temperature must not exceed 200 °C. The dissipated power is simply calculated by the following ratio:

$$P = \frac{\Delta T}{[R_{th(j-c)}] + [R_{th(c-h)}] + [R_{th(h-a)}]}$$

P: Expressed in W

ΔT: Difference between maximum working temperature and room temperature or fluid cooling temperature.

R_{th(j-c)}: Thermal resistance value measured between resistive layer and outer side of the resistor. It is the thermal resistance of the component: 0.039 °C/W.

R_{th(c-h)}: Thermal resistance value measured between outer side of the resistor and upper side of the heatsink. This is the thermal resistance of the interface (grease, thermal pad), and the quality of the fastening device.

R_{th(h-a)}: Thermal resistance of the heatsink.

Example:

R_{th(c-h)} + R_{th(h-a)} for LPS 1100 power dissipation 850 W at + 18 °C fluid temperature.

$$\Delta T \leq 200 \text{ °C} - 18 \text{ °C} = 182 \text{ °C}$$

$$R_{th(j-c)} + R_{TH(c-h)} + R_{TH(h-a)} = \frac{\Delta T}{P} = \frac{182}{850} = 0.214 \text{ °C/W}$$

$$R_{th(j-c)} = 0.039 \text{ °C/W}$$

$$R_{th(c-h)} + R_{th(h-a)} = 0.214 \text{ °C/W} - 0.039 \text{ °C/W} = 0.175 \text{ °C/W}$$

	CONFIG. 1: WATER COOLING HEATSINK CP15 AND THERMAL GREASE SI340	CONFIG. 2: AIR COOLING HEATSINK P207/250 AND THERMAL GREASE SI340	CONFIG. 3: WATER COOLING HEATSINK CP15 AND THERMAL PAD Q-PAD II	CONFIG. 4: AIR COOLING HEATSINK P207/250 AND THERMAL PAD Q-PAD II
Power Dissipation (W)	1100	350	650	285
T° Resistive Element (°C)	200	200	200	200
R _{th(j-c)} max. (°C/W)	0.039	0.039	0.039	0.039
R _{th(c-h)} typ. (°C/W)	0.070	0.201	0.187	0.315
R _{th(h-a)} max. (°C/W)	0.059	0.260	0.059	0.260
Fluid T° (°C)	15 (water)	25 (air)	15 (water)	25 (air)

Note

- Configuration 1: Water cooling heatsink (CP15 from Lytron (304 mm x 95.3 mm x 8 mm) with water flow rate 4LPM and thermal grease Si340 from BlueStar Silicones
- Configuration 2: Air cooling heatsink P207/250 from Semikron (250 mm x 200 mm x 72 mm) and thermal grease Si340 from BlueStar Silicones
- Configuration 3: Water cooling heatsink (CP15 from Lytron (304 mm x 95.3 mm x 8 mm) with water flow rate 4LPM and thermal pad Q-pad II from Berquist
- Configuration 4: Air cooling heatsink P207/250 from Semikron (250 mm x 200 mm x 72 mm) and thermal pad Q-pad II from Berquist

OVERLOAD

In any case the applied voltage must be lower than $U_1 = 6600$ V.

Short time overload: $2 \times Pr/10$ s for heatsink with $R_{th(h-a)} \geq 0.26$ °C/W (maximum power: 700 W) and $1.6 \times Pr/1$ s for heatsink with 0.26 °C/W $> R_{th(h-a)} \geq 0.059$ °C/W (maximum power: 1800 W).

Accidental overload: The values indicated on the following graph are applicable to resistors in air or mounted onto a heatsink.

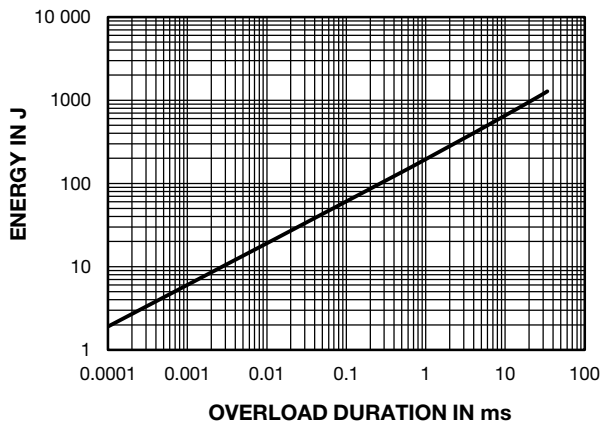
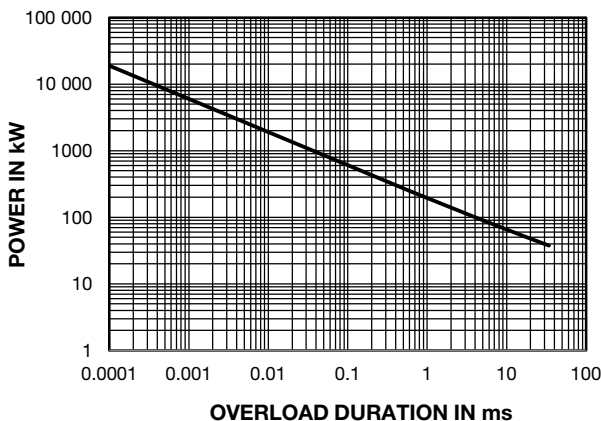
ENERGY CURVE

POWER CURVE

MARKING

Series, style, ohmic value (in Ω), tolerance (in %), manufacturing date, Vishay Sfernice trademark.

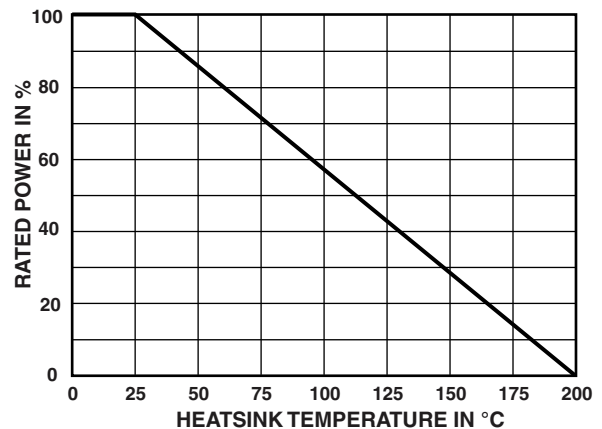
POWER RATING

The temperature of the case should be maintained within the limit specified in the following figure. To optimize the thermal conduction, contacting surfaces should be coated with silicone grease or thermal film, and heatsink mounting screws tightened to 2 Nm.

PACKAGING

Box of 15 units



ORDERING INFORMATION						
LPS	1100	1 kΩ	± 1 %	xxx	BO15	e
MODEL	STYLE	RESISTANCE VALUE	TOLERANCE	CUSTOM DESIGN	PACKAGING	LEAD (Pb)-FREE
			± 1 % ± 2 % ± 5 % ± 10 %	Optional on request: special TCR, shape, etc.		

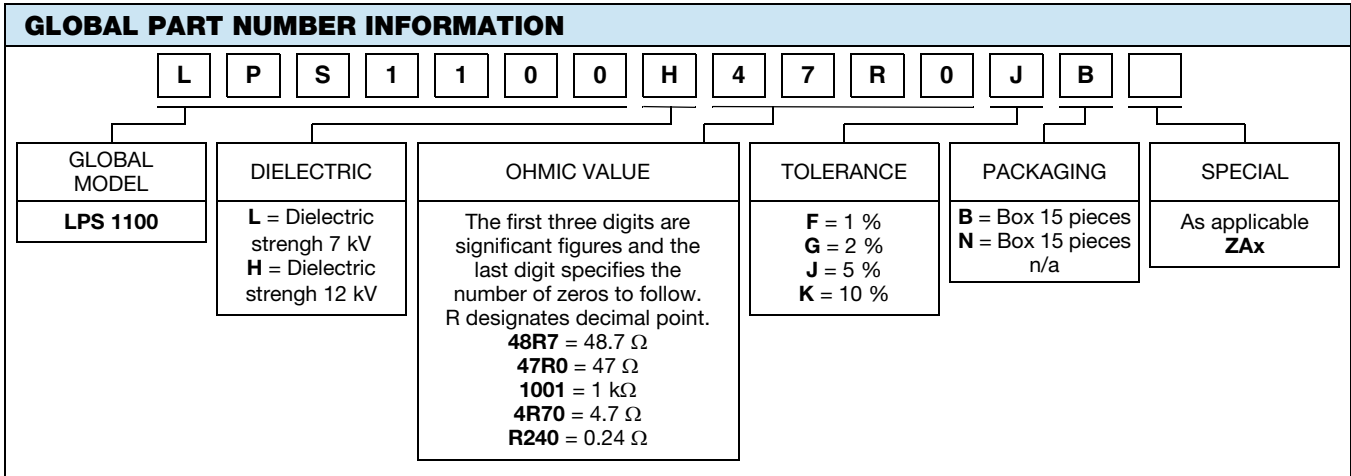



Disclaimer

ALL PRODUCT, PRODUCT SPECIFICATIONS AND DATA ARE SUBJECT TO CHANGE WITHOUT NOTICE TO IMPROVE RELIABILITY, FUNCTION OR DESIGN OR OTHERWISE.

Vishay Intertechnology, Inc., its affiliates, agents, and employees, and all persons acting on its or their behalf (collectively, "Vishay"), disclaim any and all liability for any errors, inaccuracies or incompleteness contained in any datasheet or in any other disclosure relating to any product.

Vishay makes no warranty, representation or guarantee regarding the suitability of the products for any particular purpose or the continuing production of any product. To the maximum extent permitted by applicable law, Vishay disclaims (i) any and all liability arising out of the application or use of any product, (ii) any and all liability, including without limitation special, consequential or incidental damages, and (iii) any and all implied warranties, including warranties of fitness for particular purpose, non-infringement and merchantability.

Statements regarding the suitability of products for certain types of applications are based on Vishay's knowledge of typical requirements that are often placed on Vishay products in generic applications. Such statements are not binding statements about the suitability of products for a particular application. It is the customer's responsibility to validate that a particular product with the properties described in the product specification is suitable for use in a particular application. Parameters provided in datasheets and/or specifications may vary in different applications and performance may vary over time. All operating parameters, including typical parameters, must be validated for each customer application by the customer's technical experts. Product specifications do not expand or otherwise modify Vishay's terms and conditions of purchase, including but not limited to the warranty expressed therein.

Except as expressly indicated in writing, Vishay products are not designed for use in medical, life-saving, or life-sustaining applications or for any other application in which the failure of the Vishay product could result in personal injury or death. Customers using or selling Vishay products not expressly indicated for use in such applications do so at their own risk. Please contact authorized Vishay personnel to obtain written terms and conditions regarding products designed for such applications.

No license, express or implied, by estoppel or otherwise, to any intellectual property rights is granted by this document or by any conduct of Vishay. Product names and markings noted herein may be trademarks of their respective owners.

Material Category Policy

Vishay Intertechnology, Inc. hereby certifies that all its products that are identified as RoHS-Compliant fulfill the definitions and restrictions defined under Directive 2011/65/EU of The European Parliament and of the Council of June 8, 2011 on the restriction of the use of certain hazardous substances in electrical and electronic equipment (EEE) - recast, unless otherwise specified as non-compliant.

Please note that some Vishay documentation may still make reference to RoHS Directive 2002/95/EC. We confirm that all the products identified as being compliant to Directive 2002/95/EC conform to Directive 2011/65/EU.

Vishay Intertechnology, Inc. hereby certifies that all its products that are identified as Halogen-Free follow Halogen-Free requirements as per JEDEC JS709A standards. Please note that some Vishay documentation may still make reference to the IEC 61249-2-21 definition. We confirm that all the products identified as being compliant to IEC 61249-2-21 conform to JEDEC JS709A standards.



Компания «ЭлектроПласт» предлагает заключение долгосрочных отношений при поставках импортных электронных компонентов на взаимовыгодных условиях!

Наши преимущества:

- Оперативные поставки широкого спектра электронных компонентов отечественного и импортного производства напрямую от производителей и с крупнейших мировых складов;
- Поставка более 17-ти миллионов наименований электронных компонентов;
- Поставка сложных, дефицитных, либо снятых с производства позиций;
- Оперативные сроки поставки под заказ (от 5 рабочих дней);
- Экспресс доставка в любую точку России;
- Техническая поддержка проекта, помощь в подборе аналогов, поставка прототипов;
- Система менеджмента качества сертифицирована по Международному стандарту ISO 9001;
- Лицензия ФСБ на осуществление работ с использованием сведений, составляющих государственную тайну;
- Поставка специализированных компонентов (Xilinx, Altera, Analog Devices, Intersil, Interpoint, Microsemi, Aeroflex, Peregrine, Syfer, Eurofarad, Texas Instrument, Miteq, Cobham, E2V, MA-COM, Hittite, Mini-Circuits, General Dynamics и др.);

Помимо этого, одним из направлений компании «ЭлектроПласт» является направление «Источники питания». Мы предлагаем Вам помощь Конструкторского отдела:

- Подбор оптимального решения, техническое обоснование при выборе компонента;
- Подбор аналогов;
- Консультации по применению компонента;
- Поставка образцов и прототипов;
- Техническая поддержка проекта;
- Защита от снятия компонента с производства.



Как с нами связаться

Телефон: 8 (812) 309 58 32 (многоканальный)

Факс: 8 (812) 320-02-42

Электронная почта: org@eplast1.ru

Адрес: 198099, г. Санкт-Петербург, ул. Калинина, дом 2, корпус 4, литера А.