



LEOPARD IMAGING INC

LI-XAVIER-KIT-IMX577M12-X Data Sheet

Key Features

- Compatible with Nvidia® Jetson AGX Xavier™ Developer Kit
- MIPI CSI-2 interface
- Support up to six cameras
- Two adapter board options
 - LI-JXAV-MIPI-ADPT-4CAM
 - LI-JXAV-MIPI-ADPT-6CAM-FP
- Sony Diagonal 7.857 mm (Type 1/2.3) CMOS Image Sensor IMX577
- Active pixels: 4056H x 3040V
- Color camera
- Length of the I-PEX cable: 300mm
- Support multiple length cables
- Connector Part#: 20525-030E-02C
- Provide customization services
- Part#:
 - (1 cam) [LI-XAVIER-KIT-IMX577M12](#)
 - (2 cam) [LI-XAVIER-KIT-IMX577M12-D](#)
 - (3 cam) [LI-XAVIER-KIT-IMX577M12-T](#)
 - (4 cam) [LI-XAVIER-KIT-IMX577M12-Q](#)
 - (6 cam) [LI-XAVIER-KIT-IMX577M12-H](#)

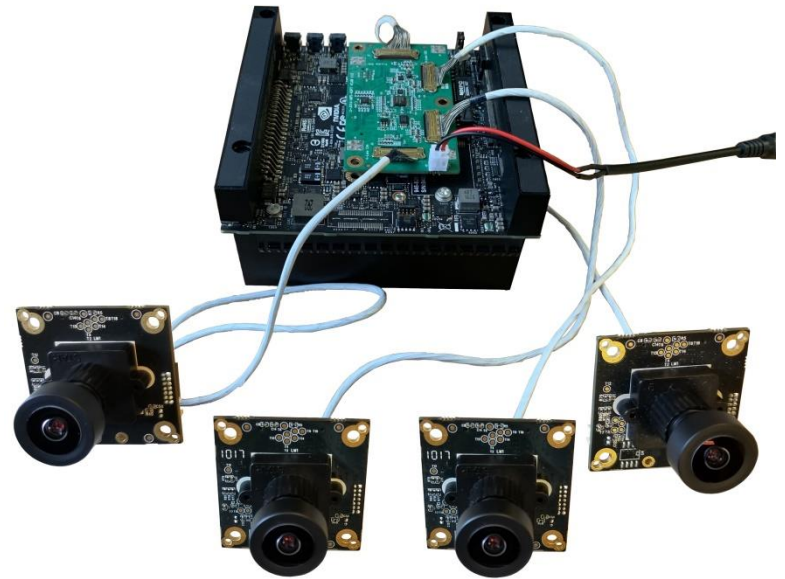

Lens Spec

- Model: SYD1201A
- Focal length: 3.7 mm
- Aperture, F/#: 2.8 +/- 5%
- Built in 650nm IR cut filter
- FOV (D/H/V): 100° / 86° / 69°
- TV Distortion: -1.0 %
- M12 x P0.5

Applications

- Industrial Applications
- Intelligent Transportation System (ITS) Cameras

BOM

Nvidia AGX Xavier Developer Kit not included

#	Items	QTY
1	LI-JXAV-MIPI-ADPT-4CAM or LI-JXAV-MIPI-ADPT-6CAM-FP	1
2	LI-IMX577-MIPI-M12	1, 2, 3, 4 or 6
3	FAW-1233-03 cable	1, 2, 3, 4 or 6



Leopard Imaging Inc.

48820 Kato Rd, Suite 100B, Fremont, CA 94538, USA
 Phone: +1-408-263-0988
 Fax: +1-408-217-1960
 Email: sales@leopardimaging.com
 Website: www.leopardimaging.com

LI-XAVIER-KIT-IMX577M12

BOM

#	Items	QTY
1	LI-JXAV-MIPI-ADPT-4CAM	1
2	LI-IMX577-MIPI-M12	1
3	FAW-1233-03 cable	1

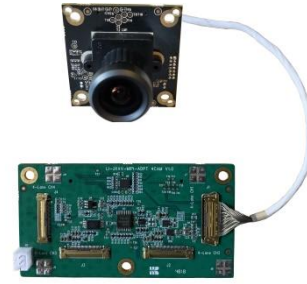

LI-XAVIER-KIT-IMX577M12-D

BOM

#	Items	QTY
1	LI-JXAV-MIPI-ADPT-4CAM	1
2	LI-IMX577-MIPI-M12	2
3	FAW-1233-03 cable	2



LI-XAVIER-KIT-IMX577M12-T

BOM

#	Items	QTY
1	LI-JXAV-MIPI-ADPT-4CAM	1
2	LI-IMX577-MIPI-M12	3
3	FAW-1233-03 cable	3

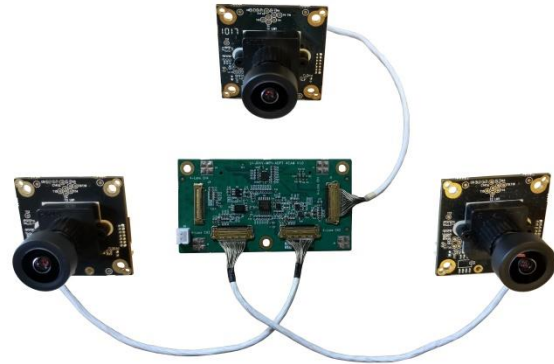

LI-XAVIER-KIT-IMX577M12-Q

BOM

#	Items	QTY
1	LI-JXAV-MIPI-ADPT-4CAM	1
2	LI-IMX577-MIPI-M12	4
3	FAW-1233-03 cable	4

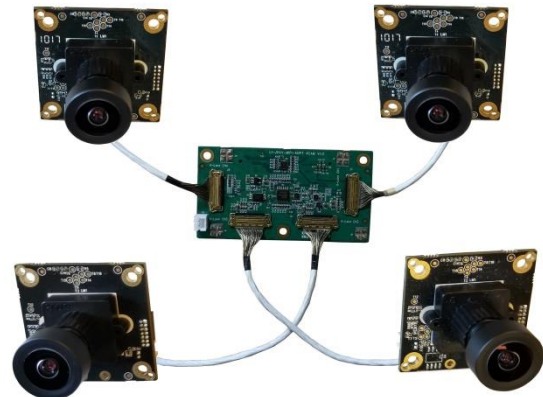

Leopard Imaging Inc.

48820 Kato Rd, Suite 100B, Fremont, CA 94538, USA
Phone: +1-408-263-0988
Fax: +1-408-217-1960
Email: sales@leopardimaging.com
Website: www.leopardimaging.com

LI-XAVIER-KIT-IMX577M12-H

BOM

#	Items	QTY
1	LI-JXAV-MIPI-ADPT-6CAM-FP	1
2	LI-IMX577-MIPI-M12	6
3	FAW-1233-03 cable	6

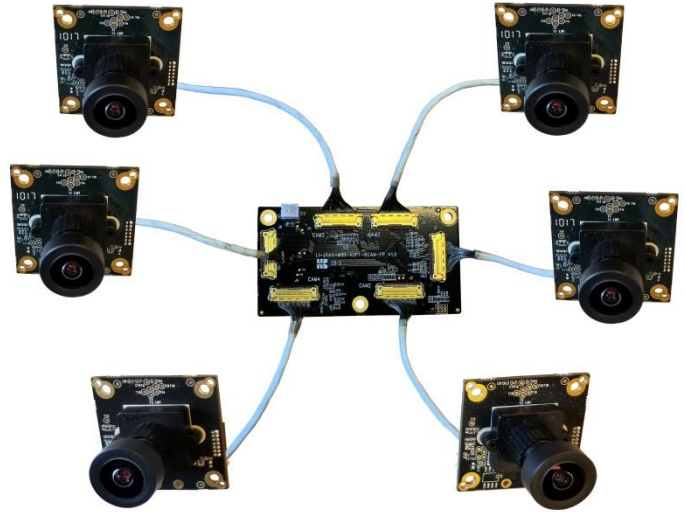

LI-XAVIER-KIT-IMX577M12-6CAM-Q

BOM

#	Items	QTY
1	LI-JXAV-MIPI-ADPT-6CAM-FP	1
2	LI-IMX577-MIPI-M12	4
3	FAW-1233-03 cable	4

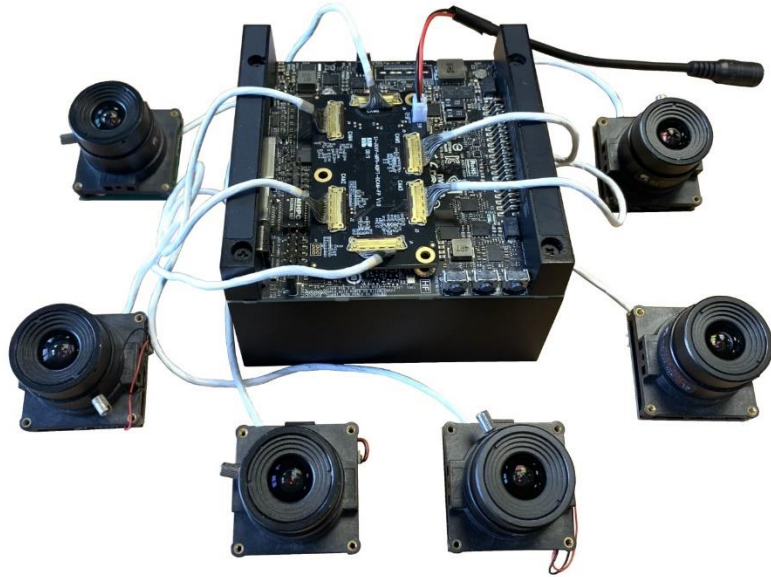
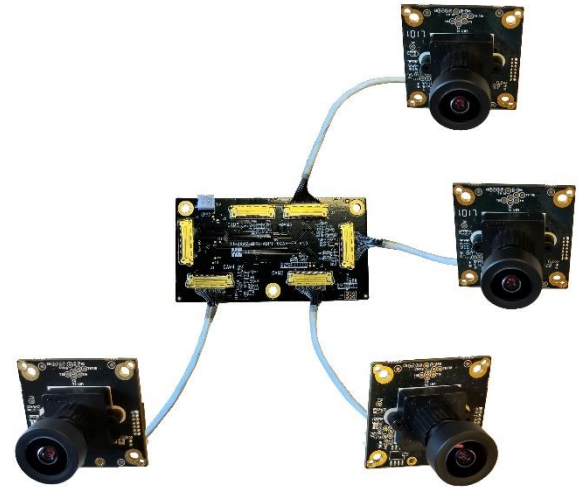

Leopard Imaging Inc.

48820 Kato Rd, Suite 100B, Fremont, CA 94538, USA
Phone: +1-408-263-0988
Fax: +1-408-217-1960
Email: sales@leopardimaging.com
Website: www.leopardimaging.com

Dimensions

LI-IMX577-MIPI-M12

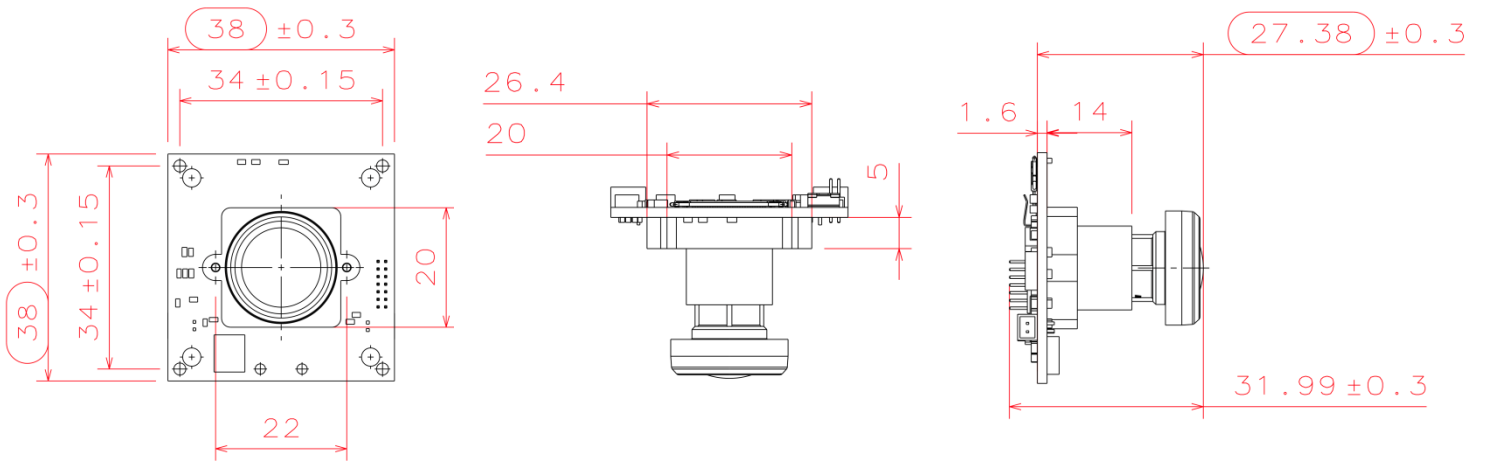

LI-JXAV-MIPI-ADPT-4CAM

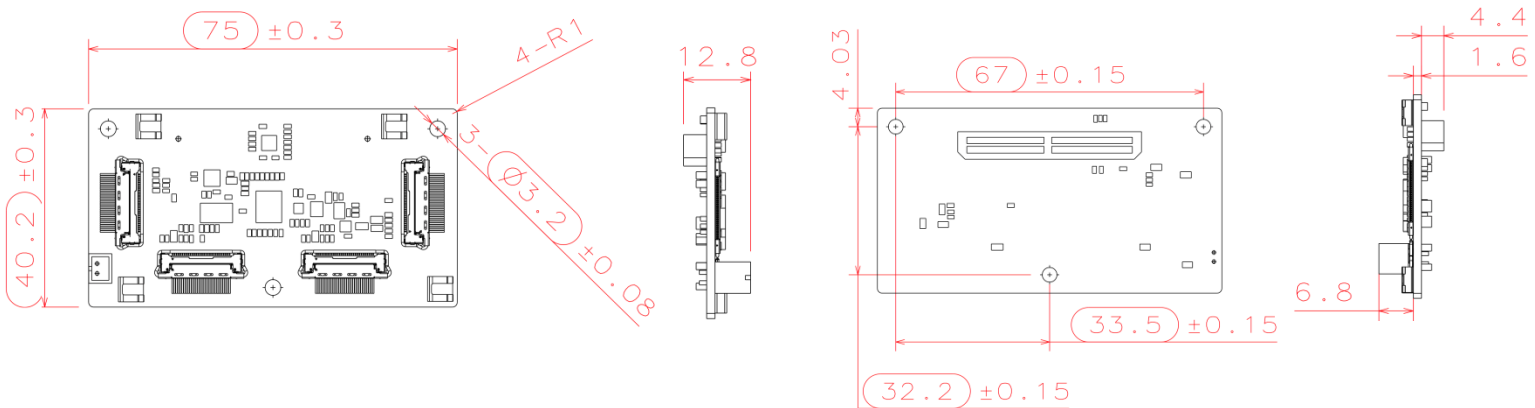

FAW-1233-03

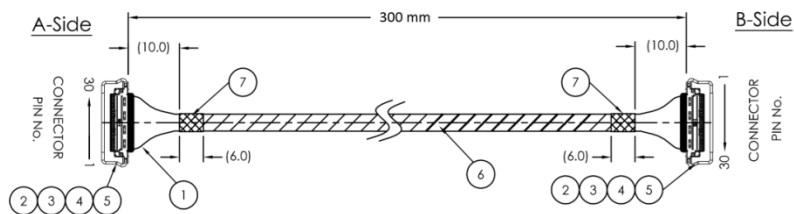

Leopard Imaging Inc.

48820 Kato Rd, Suite 100B, Fremont, CA 94538, USA
 Phone: +1-408-263-0988
 Fax: +1-408-217-1960
 Email: sales@leopardimaging.com
 Website: www.leopardimaging.com

LI-JXAV-MIPI-ADPT-4CAM

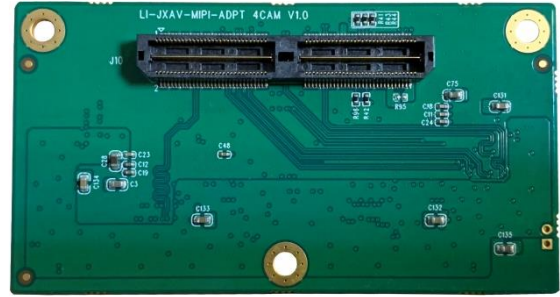

Interfaces

Interface J1

- Part#: 20525-030E-02C
- Number of Positions: 30
- Pitch: 0.4mm
- Mating I-PEX cable: FAW-1233-03 (300mm)

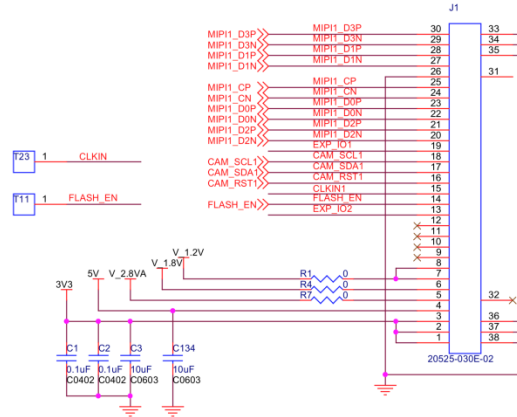

Interface J2

- Part#: 20525-030E-02C
- Number of Positions: 30
- Pitch: 0.4mm
- Mating I-PEX cable: FAW-1233-03 (300mm)

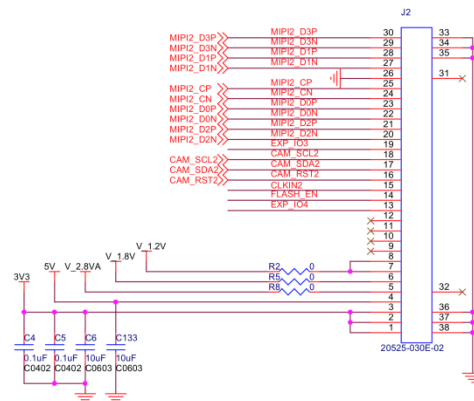

Interface J3

- Part#: 20525-030E-02C
- Number of Positions: 30
- Pitch: 0.4mm
- Mating I-PEX cable: FAW-1233-03 (300mm)

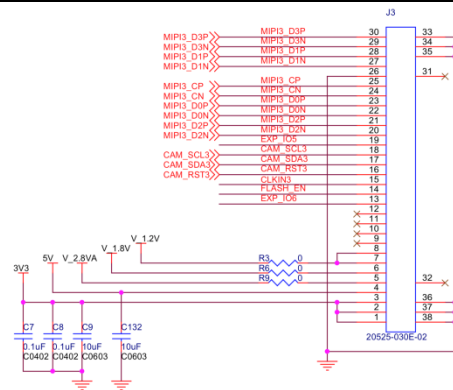

Leopard Imaging Inc.

48820 Kato Rd, Suite 100B, Fremont, CA 94538, USA
 Phone: +1-408-263-0988
 Fax: +1-408-217-1960
 Email: sales@leopardimaging.com
 Website: www.leopardimaging.com

Interface J4

- Part#: 20525-030E-02C
- Number of Positions: 30
- Pitch: 0.4mm
- Mating I-PEX cable: FAW-1233-03 (300mm)

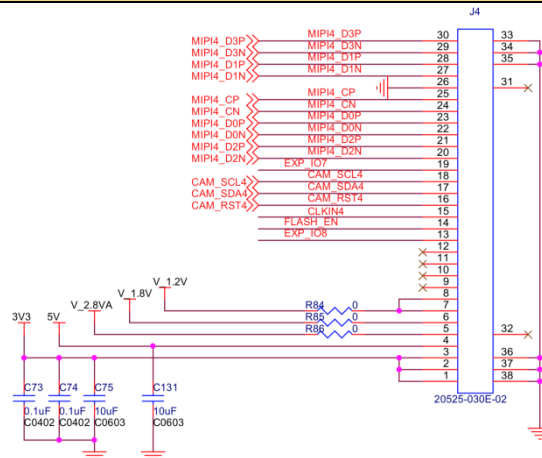

Interface J5

- Part#: 0894000220
- Number of Positions: 2
- Pitch: 2mm

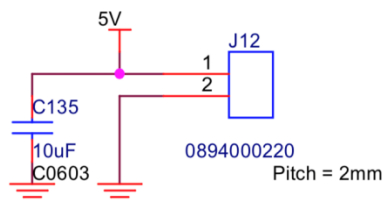

Interface J10

- Part#: QTH-060-01-L-D-A
- Number of Positions: 120
- Number of Rows: 2
- Pitch: 0.5 mm

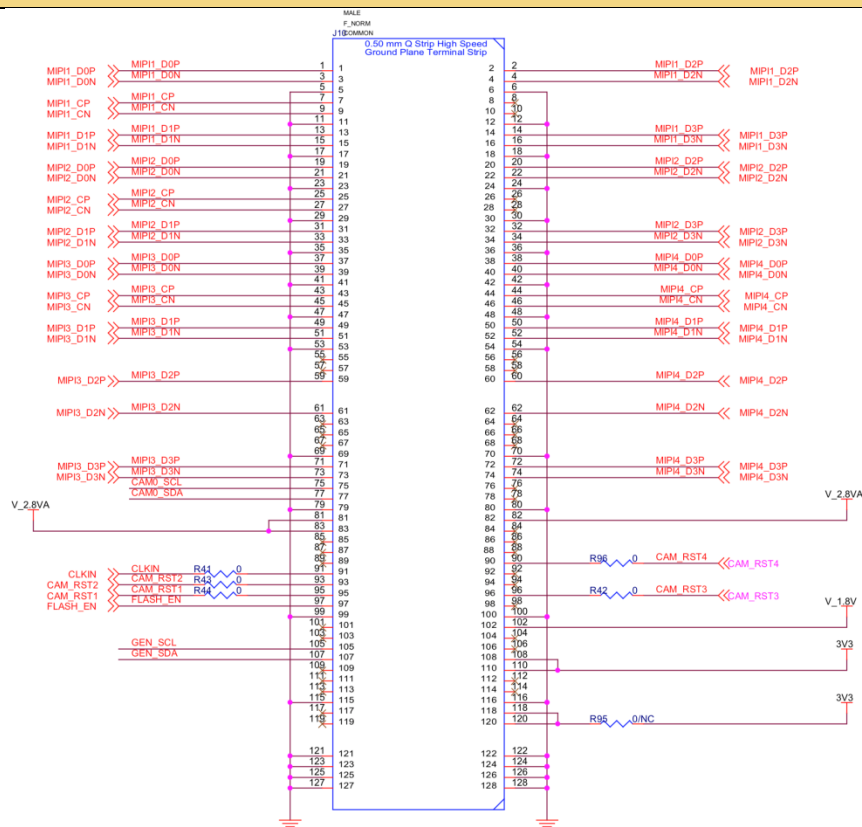

Leopard Imaging Inc.

48820 Kato Rd, Suite 100B, Fremont, CA 94538, USA
 Phone: +1-408-263-0988
 Fax: +1-408-217-1960
 Email: sales@leopardimaging.com
 Website: www.leopardimaging.com

LI-JXAV-MIPI-ADPT-6CAM-FP

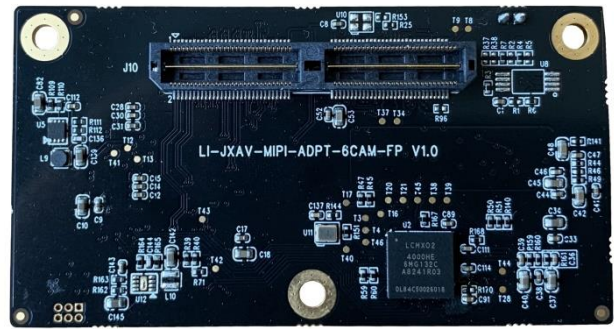
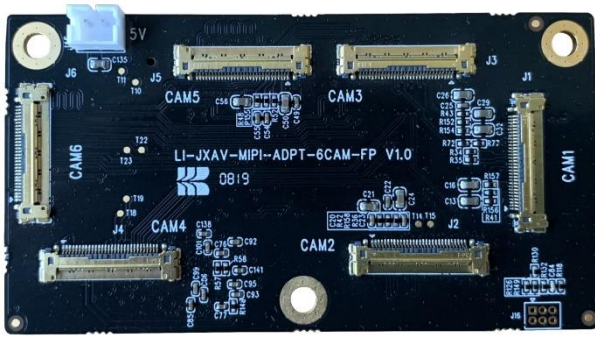

Interfaces

Interface J1 (camera channel 1)

- Part#: 20525-030E-02C
- Number of Positions: 30
- Pitch: 0.4mm
- Mating I-PEX cable: FAW-1233-xx

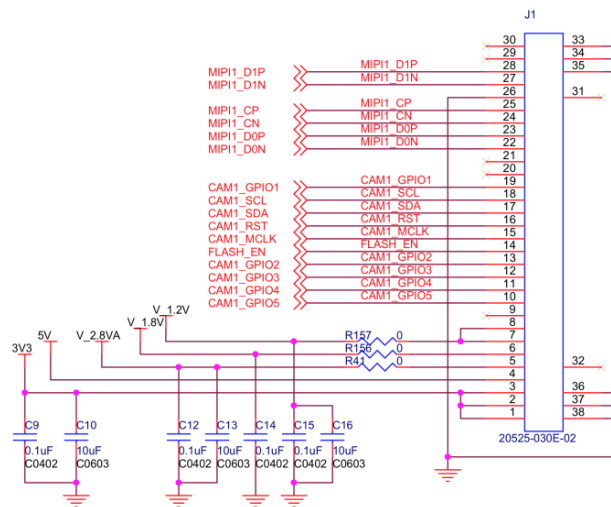

Interface J2 (camera channel 2)

- Part#: 20525-030E-02C
- Number of Positions: 30
- Pitch: 0.4mm
- Mating I-PEX cable: FAW-1233-xx

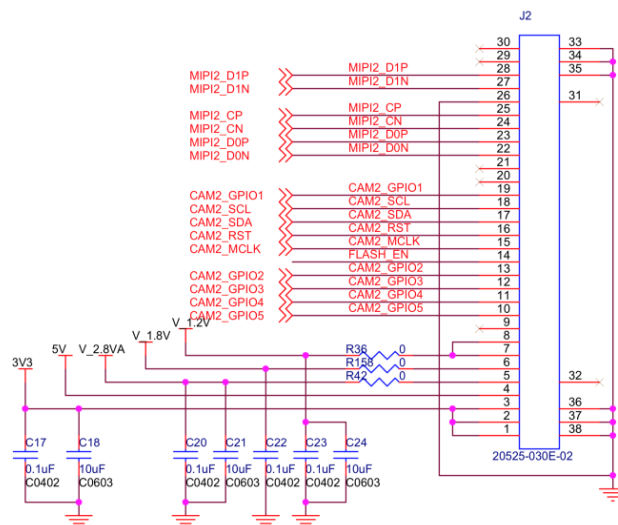

Leopard Imaging Inc.

48820 Kato Rd, Suite 100B, Fremont, CA 94538, USA
 Phone: +1-408-263-0988
 Fax: +1-408-217-1960
 Email: sales@leopardimaging.com
 Website: www.leopardimaging.com

Interface J3 (camera channel 3)

- Part#: 20525-030E-02C
- Number of Positions: 30
- Pitch: 0.4mm
- Mating I-PEX cable: FAW-1233-xx

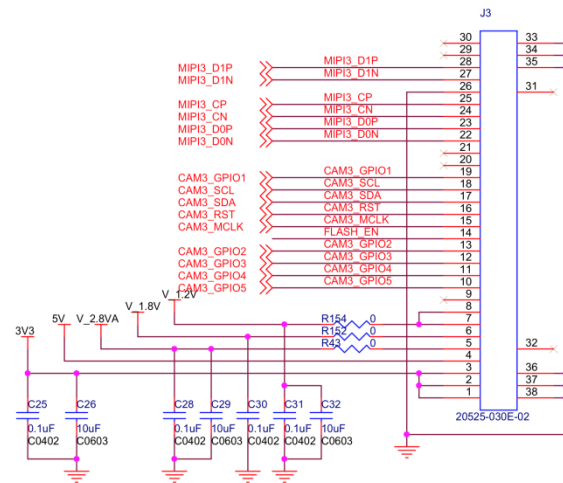

Interface J4 (camera channel 4)

- Part#: 20525-030E-02C
- Number of Positions: 30
- Pitch: 0.4mm
- Mating I-PEX cable: FAW-1233-xx

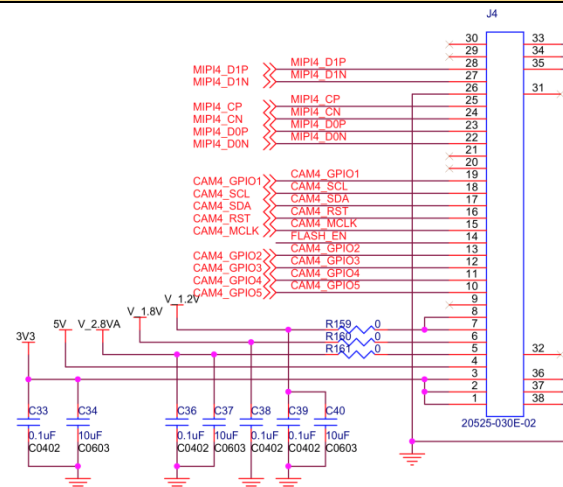

Interface J5 (camera channel 5)

- Part#: 20525-030E-02C
- Number of Positions: 30
- Pitch: 0.4mm
- Mating I-PEX cable: FAW-1233-xx

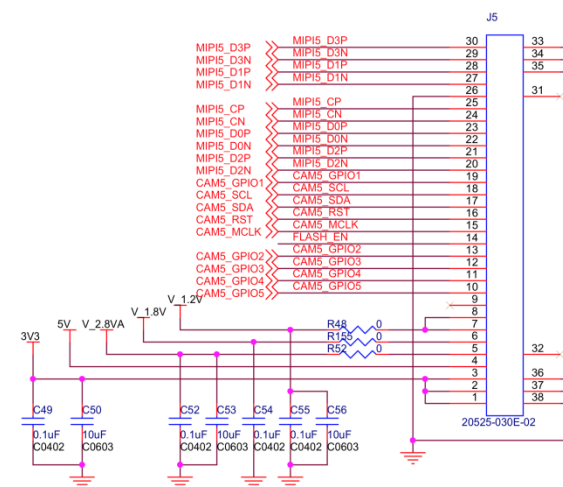

Leopard Imaging Inc.

48820 Kato Rd, Suite 100B, Fremont, CA 94538, USA
 Phone: +1-408-263-0988
 Fax: +1-408-217-1960
 Email: sales@leopardimaging.com
 Website: www.leopardimaging.com

Interface J6 (camera channel 6)

- Part#: 20525-030E-02C
- Number of Positions: 30
- Pitch: 0.4mm
- Mating I-PEX cable:
FAW-1233-xx

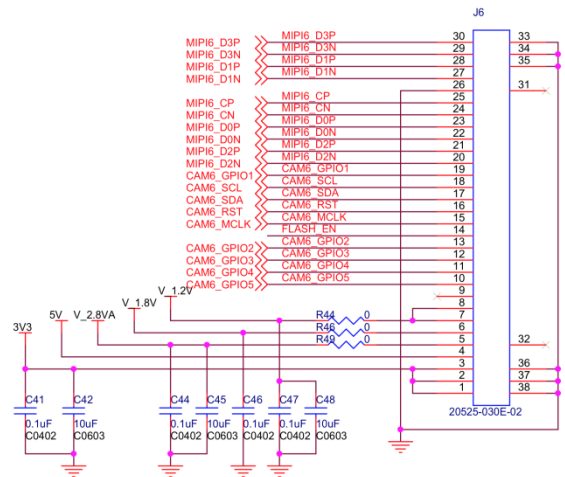

Interface J16 (FPGA programming interface)

- Part#: 20021311-00006T4LF
- Number of Positions: 6
- Pitch: 0.050" (1.27mm)
- Number of Rows: 2

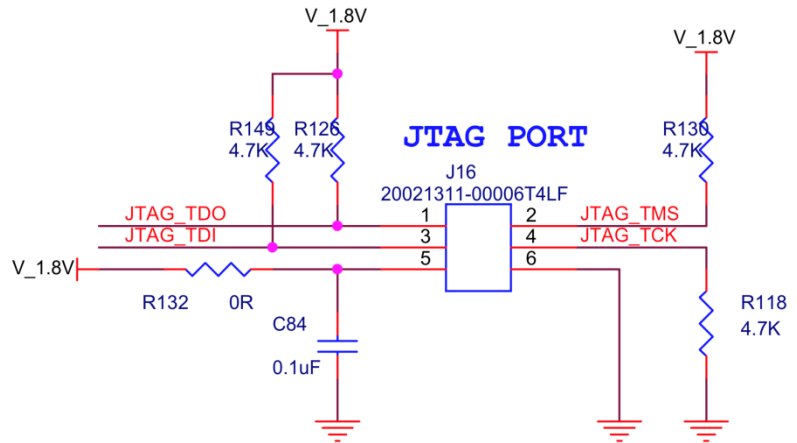

Interface J15 (External power input interface)

- Part#: 0894000220
- Number of Positions: 2
- Pitch: 2 mm

External Input Power

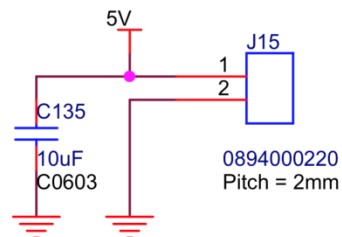

Leopard Imaging Inc.

48820 Kato Rd, Suite 100B, Fremont, CA 94538, USA
 Phone: +1-408-263-0988
 Fax: +1-408-217-1960
 Email: sales@leopardimaging.com
 Website: www.leopardimaging.com

Interface J10 (To Xavier)

- Part#: QTH-060-01-L-D-A
- Number of Positions: 120
- Number of Rows: 2
- Pitch: 0.5 mm

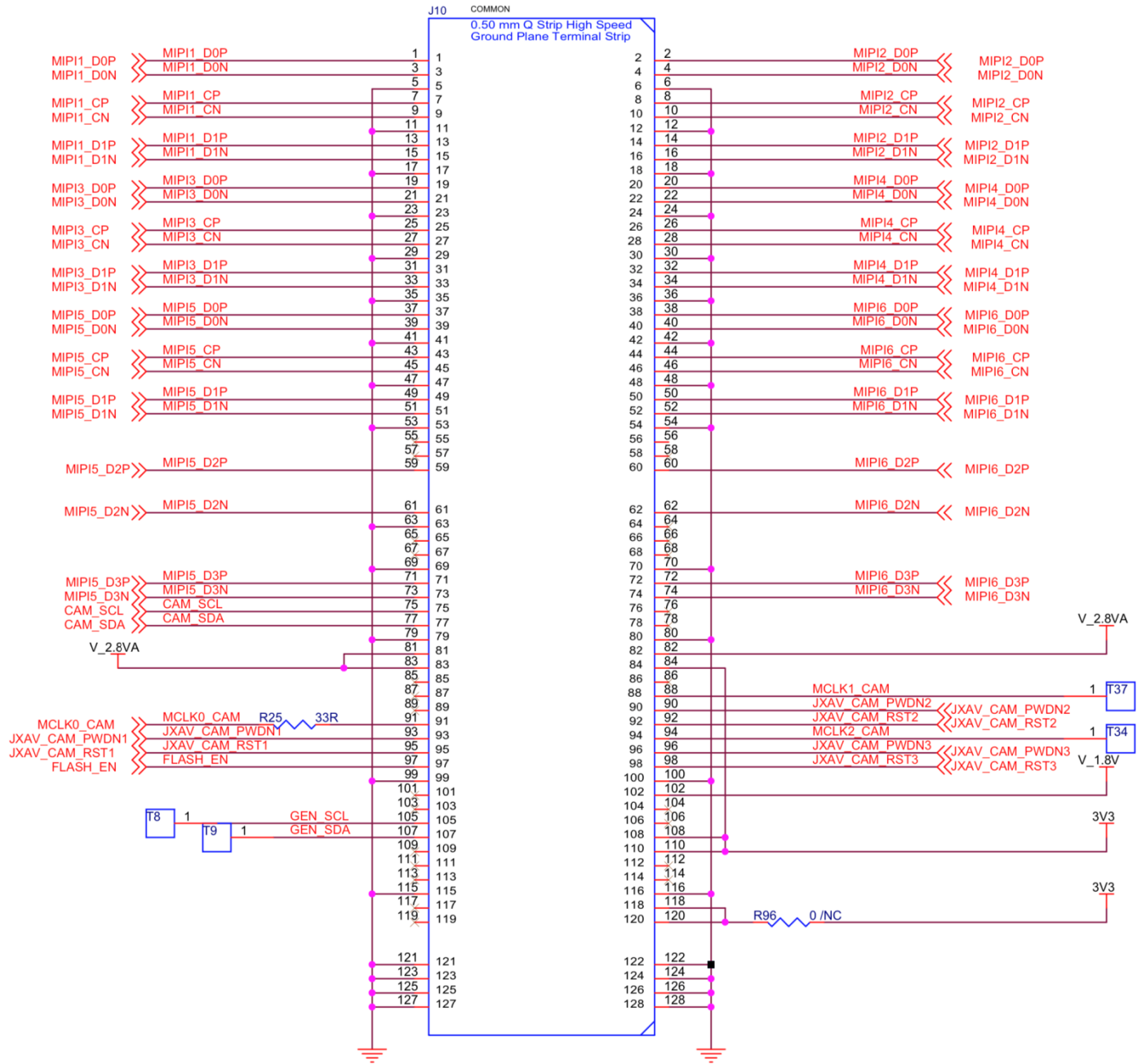

Leopard Imaging Inc.

48820 Kato Rd, Suite 100B, Fremont, CA 94538, USA
 Phone: +1-408-263-0988
 Fax: +1-408-217-1960
 Email: sales@leopardimaging.com
 Website: www.leopardimaging.com

LI-IMX577-MIPI-M12

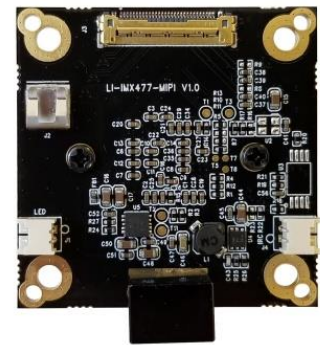

Camera Spec	
Image Sensor	Sony Diagonal 7.857 mm (Type 1/2.3) CMOS Image Sensor IMX577
Optical format	1/2.3"
Number of active pixels	4056 (H) x 3040 (V)
Pixel size	1.55um (H) x 1.55um (V)
Color or Mono	Color
Interface	MIPI interface
Lens mount	M12
Weight	14 g
Interfaces	
Interface J3:	<ul style="list-style-type: none"> Part#: 20525-030E-02C Number of Positions: 30 Pitch: 0.4mm Mating I-PEX cable: FAW-1233-03 (300mm)
Interface J4:	<ul style="list-style-type: none"> Part#: 1734829-2 Number of Positions: 2 Pitch: 1.25mm
Interface J1:	<ul style="list-style-type: none"> Part#: 1734829-2 Number of Positions: 2 Pitch: 1.25mm



Leopard Imaging Inc.

48820 Kato Rd, Suite 100B, Fremont, CA 94538, USA
 Phone: +1-408-263-0988
 Fax: +1-408-217-1960
 Email: sales@leopardimaging.com
 Website: www.leopardimaging.com

Absolute Maximum Ratings

Item	Symbol	Ratings	Unit	notes
Supply voltage (analog)	V _{ANA}	-0.3 to +3.3	V	refer to V _{SS} level
Supply voltage (digital)	V _{DIG}	-0.3 to +1.8	V	
Supply voltage (interface)	V _{IF}	-0.3 to +3.3	V	
Input voltage (digital)	V _I	-0.3 to +3.3	V	
Output voltage (digital)	V _O	-0.3 to +3.3	V	
Guaranteed operating temperature	T _{OPR}	-20 to +75	°C	
Guaranteed storage temperature	T _{STG}	-30 to +80	°C	
Guaranteed performance temperature	T _{SPEC}	-20 to +60	°C	

Recommended Operating Conditions

Item	Symbol	Ratings	Unit	notes
Supply voltage (analog)	V _{ANA} ^{*1}	2.8 ± 0.1	V	refer to V _{SS} level
Supply voltage (digital)	V _{DIG} ^{*2}	1.05 ± 0.1	V	
Supply voltage (interface)	V _{IF} ^{*3}	1.8 ± 0.1	V	

- ^{*1} V_{ANA}: V_{DDSUB}, V_{DDHAN}, V_{DDHCM1} to 2, V_{DDHSN1} to 4 (2.8 V power supply)
^{*2} V_{DIG}: V_{DDLSC1} to 4, V_{DDLGN1} to 2, V_{DDLPL1} to 2, V_{DDLIF} (1.05 V power supply)
^{*3} V_{IF}: V_{DDMIO1} to 2, V_{DDMIF} (1.8 V power supply)

Spectral Sensitivity Characteristics

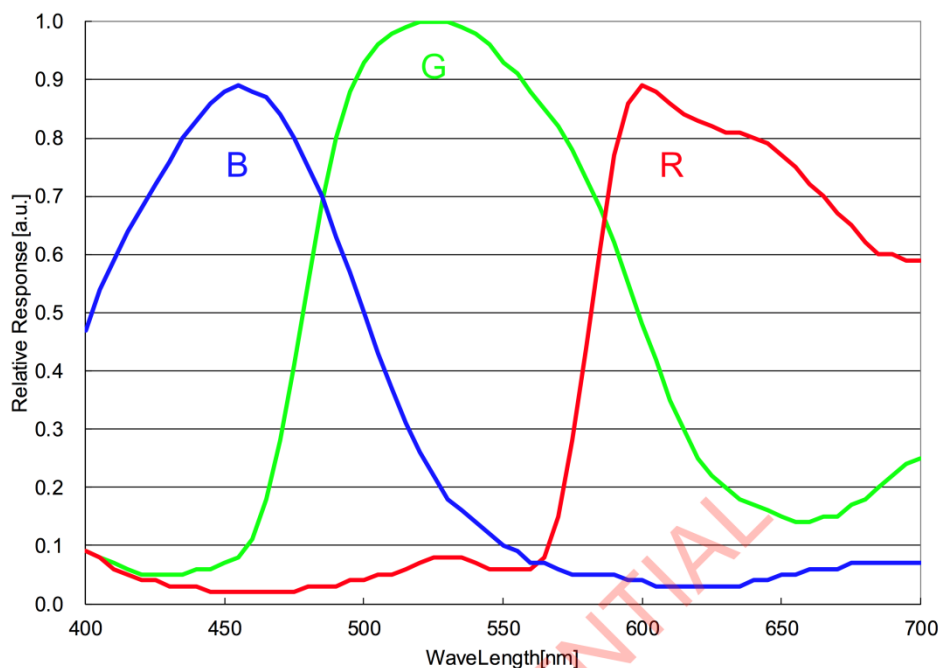

DC Characteristics

Item	Pins	Symbol	Conditions	Min.	Typ.	Max.	Unit
Supply voltage	V _{DD} SUB, V _{DD} HCM1 to 2, V _{DD} HSN1 to 4, V _{DD} HAN	V _{ANA}		2.7	2.8	2.9	V
	V _{DD} LCN1 to 2, V _{DD} LSC1 to 4, V _{DD} LIF, V _{DD} LPL1 to 2	V _{DIG}		0.95	1.05	1.15	V
	V _{DD} MIO1 to 2, V _{DD} MIF	V _{IF}		1.7	1.8	1.9	V
Digital input voltage	SDA,	V _{IH}		0.7 V _{IF}		2.9	V
	SCL	V _{IL}		- 0.3		0.3 V _{IF}	V
Digital input voltage	XCLR, INCK, GYINT,	V _{IH}		0.65 V _{IF}		V _{IF} + 0.3	V
	SDI, SLASEL	V _{IL}		- 0.3		0.35 V _{IF}	V
Digital output voltage	SDA	V _{OH}		V _{IF} - 0.4			V
		V _{OL}				0.4	V
Digital output voltage	GPO, SDO, SCSB, FSTROBE	V _{OH}		V _{IF} - 0.4			V
		V _{OL}				0.4	V



AC Characteristics

Master Clock Square Waveform Input Diagram

Input specifications are shown below when square-wave signal is input directly into the external pin INCK.

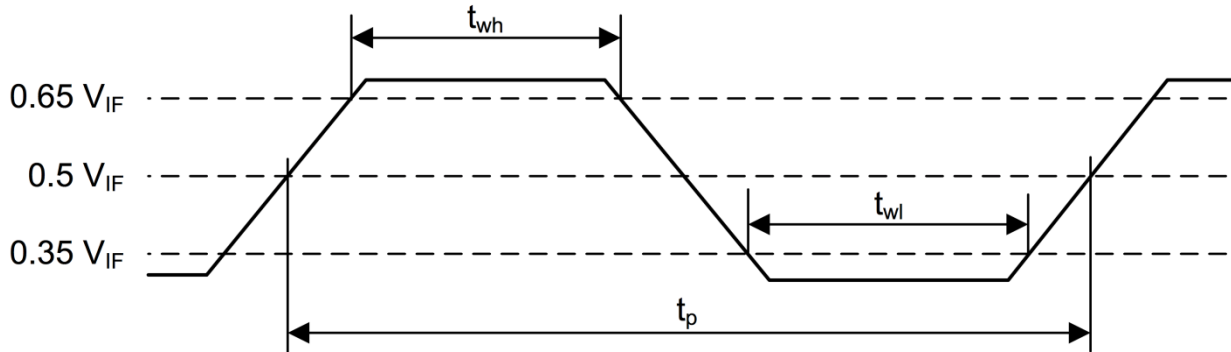

Master Clock Square Waveform Input Characteristics

PARAMETER	Symbol	Min.	Typ.	Max.	Unit
INCK clock frequency	f_{SCK}	6		27	MHz
INCK clock period	t_p	37.0		166.7	ns
INCK low level width	t_{wl}	$0.4 t_p$		$0.6 t_p$	ns
INCK high level width	t_{wh}	$0.4 t_p$		$0.6 t_p$	ns
INCK jitter	T_{jitter}			600	ps



2-wire serial communication block characteristics

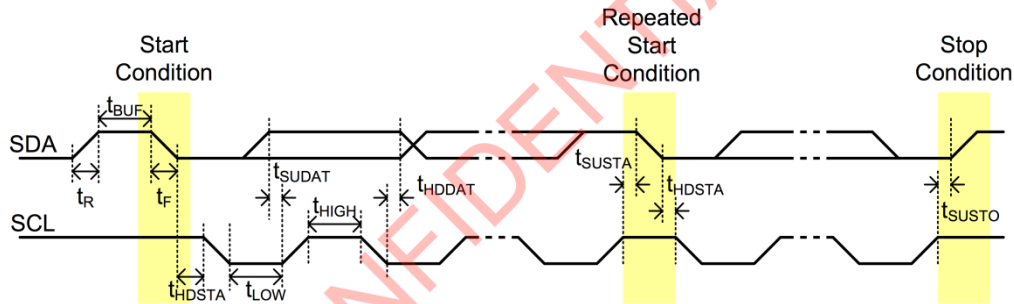

2-wire serial communication block specification

Parameter	Symbol	Conditions	Min. (Fast-mode Plus)	Max. (Fast-mode Plus)	Unit
Low level input voltage	V_{IL}		-0.5	0.3 V_{IF}	V
High level input voltage	V_{IH}		0.7 V_{IF}	2.9	V
Low level output voltage	V_{OL1}	$V_{IF} > 2$ V, Sink 3 mA	0	0.4	V
	V_{OL2}	$V_{IF} < 2$ V, Sink 3 mA	0	0.2 V_{IF}	V
Output fall time	t_{of}	Load 10 pF – 400 pF, 0.7 $V_{IF} \rightarrow$ 0.3 V_{IF}		250 (120)	ns
Input current	I_I	0.1 $V_{IF} \rightarrow$ 0.9 V_{IF}	-10	10	μ A
SDA I/O capacitance	$C_{I/O}$			10	pF
SCL Input capacitance	C_I			10	pF

2-wire serial communication block AC specification

Parameter	Symbol	Min. (Fast-mode Plus)	Max. (Fast-mode Plus)	Unit
SCL clock frequency	f_{SCL}	0	400 (1000)	kHz
Rise time (SDA and SCL)	t_R	—	300 (120)	ns
Fall time (SDA and SCL)	t_F	—	300 (120)	ns
Hold time (start condition)	t_{HDSTA}	0.6 (0.26)	—	μ s
Setup time (rep.-start condition)	t_{SUSTA}	0.6 (0.26)	—	μ s
Setup time (stop condition)	t_{SUSTO}	0.6 (0.26)	—	μ s
Data setup time	t_{SUDAT}	100 (50)	—	ns
Data hold time	t_{HDDAT}	0	—	μ s
Bus free time between Stop and Start condition	t_{BUF}	1.3 (0.5)	—	μ s
Low period of the SCL clock	t_{LOW}	1.3 (0.5)	—	μ s
High period of the SCL clock	t_{HIGH}	0.6 (0.26)	—	μ s

Note) Fast-mode Plus supports only available with INCK \geq 8.0 MHz



Leopard Imaging Inc.

48820 Kato Rd, Suite 100B, Fremont, CA 94538, USA
 Phone: +1-408-263-0988
 Fax: +1-408-217-1960
 Email: sales@leopardimaging.com
 Website: www.leopardimaging.com

Power-on Sequence

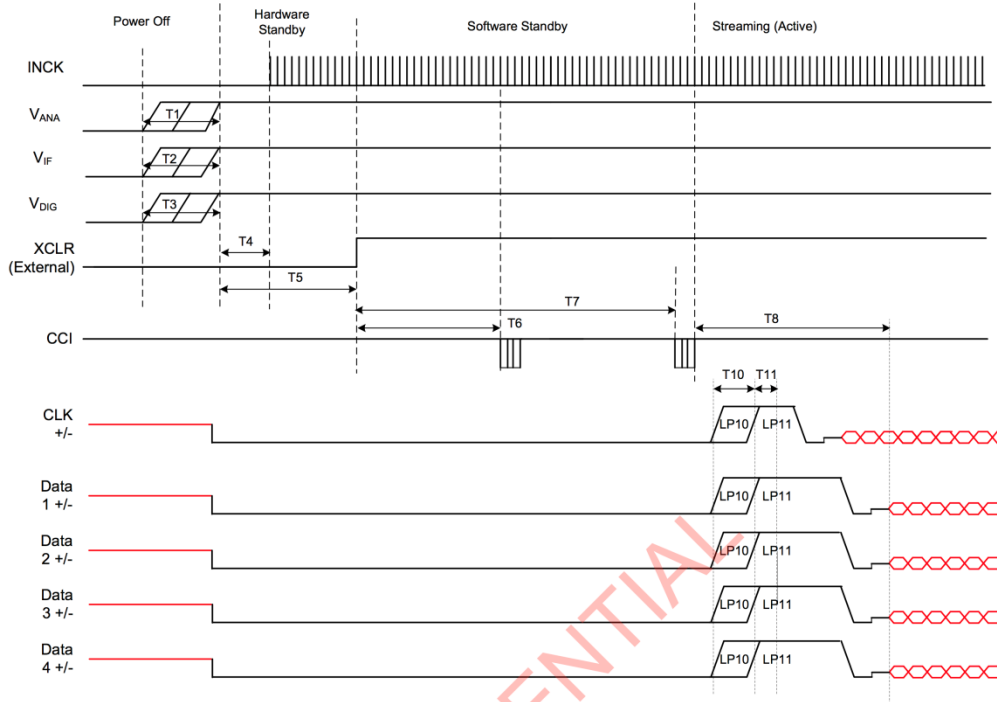

Item	Label	Min.	Max.	Unit	Comment
V _{ANA} rising – V _{ANA} ON	T1	V _{ANA} and V _{IF} and V _{DIG} may rise in any order.		µs	Slew rate of V _{ANA} , V _{IF} and V _{DIG} (0 % - 100 %): Max. 50 mV/µs
V _{IF} rising – V _{IF} ON	T2			µs	
V _{DIG} rising – V _{DIG} ON	T3			µs	
V _{ANA} and V _{IF} and V _{DIG} rising - INCK start	T4	0		µs	Presence of INCK during Power off is acceptable
V _{ANA} and V _{IF} and V _{DIG} rising - XCLR rising	T5	0		ms	After T1, T2 and T3
INCK start and XCLR rising till CCI Read version ID register wait time	T6	0.6		ms	
INCK start and XCLR rising till Send Streaming Command wait time (To complete reading all parameters from NVM)	T7	8		ms	
Start of first streaming from Sending Streaming Command.	T8		4.0 ms + The delay of the coarse integration time value		
D-PHY power up	T10	1	1.1	ms	
D-PHY init.	T11	100	110	µs	

Note) XCLR needs to be Low until all power supplies complete power-on



Leopard Imaging Inc.

48820 Kato Rd, Suite 100B, Fremont, CA 94538, USA
 Phone: +1-408-263-0988
 Fax: +1-408-217-1960
 Email: sales@leopardimaging.com
 Website: www.leopardimaging.com

Power-off Sequence

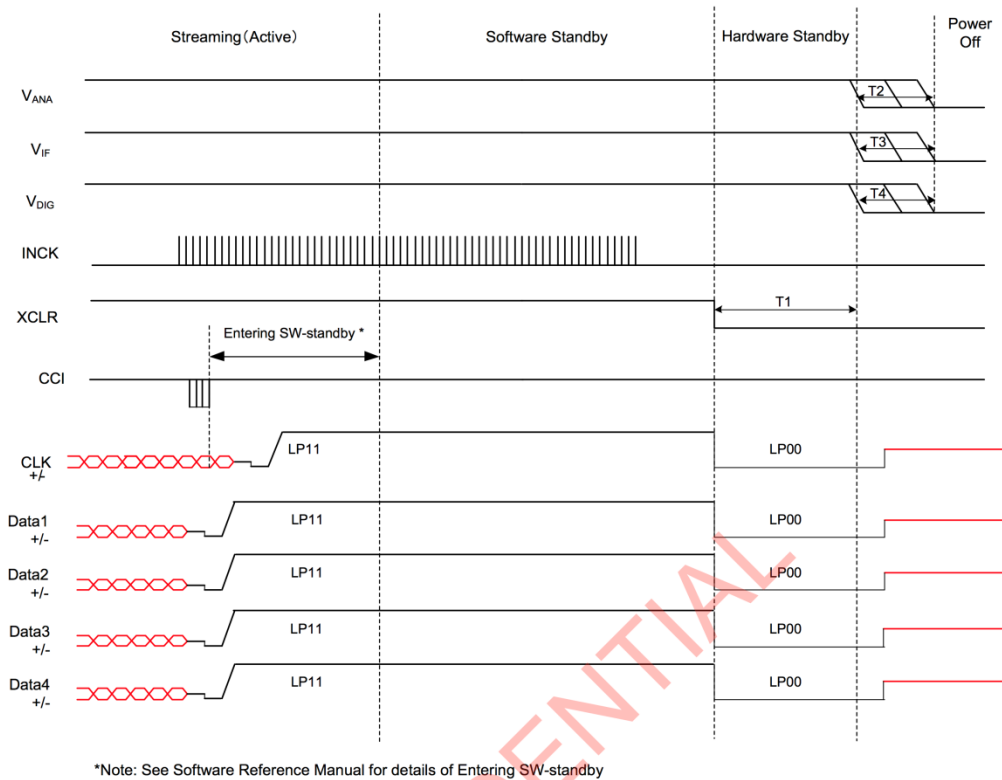

Item	Label	Min.	Max.	Unit	Comment
XCLR Neg-edge - V _{ANA} (V _{IF} or V _{DIG}) fall	T1	0		µs	Presence of INCK during Power Off is acceptable.
Sequence free of V _{ANA} falling and V _{IF} falling and V _{DIG} falling	T2,T3,T4	V _{ANA} and V _{IF} and V _{DIG} may fall in any order.		µs	



Revision History

Revision	Description	Release Date
1.0	First Release	23. Mar. 2019
1.1	Add LI-JXAV-MIPI-ADPT-6CAM-FP board	25. Jun. 2019
1.2	Add LI-XAVIER-KIT-IMX577M12-6CAM-Q	21. May. 2019



Leopard Imaging Inc.

48820 Kato Rd, Suite 100B, Fremont, CA 94538, USA
Phone: +1-408-263-0988
Fax: +1-408-217-1960
Email: sales@leopardimaging.com
Website: www.leopardimaging.com



Компания «ЭлектроПласт» предлагает заключение долгосрочных отношений при поставках импортных электронных компонентов на взаимовыгодных условиях!

Наши преимущества:

- Оперативные поставки широкого спектра электронных компонентов отечественного и импортного производства напрямую от производителей и с крупнейших мировых складов;
- Поставка более 17-ти миллионов наименований электронных компонентов;
- Поставка сложных, дефицитных, либо снятых с производства позиций;
- Оперативные сроки поставки под заказ (от 5 рабочих дней);
- Экспресс доставка в любую точку России;
- Техническая поддержка проекта, помощь в подборе аналогов, поставка прототипов;
- Система менеджмента качества сертифицирована по Международному стандарту ISO 9001;
- Лицензия ФСБ на осуществление работ с использованием сведений, составляющих государственную тайну;
- Поставка специализированных компонентов (Xilinx, Altera, Analog Devices, Intersil, Interpoint, Microsemi, Aeroflex, Peregrine, Syfer, Eurofarad, Texas Instrument, Miteq, Cobham, E2V, MA-COM, Hittite, Mini-Circuits, General Dynamics и др.);

Помимо этого, одним из направлений компании «ЭлектроПласт» является направление «Источники питания». Мы предлагаем Вам помощь Конструкторского отдела:

- Подбор оптимального решения, техническое обоснование при выборе компонента;
- Подбор аналогов;
- Консультации по применению компонента;
- Поставка образцов и прототипов;
- Техническая поддержка проекта;
- Защита от снятия компонента с производства.



Как с нами связаться

Телефон: 8 (812) 309 58 32 (многоканальный)

Факс: 8 (812) 320-02-42

Электронная почта: org@eplast1.ru

Адрес: 198099, г. Санкт-Петербург, ул. Калинина, дом 2, корпус 4, литера А.