

Common mode filter with ESD protection for high speed serial interface

Datasheet - production data

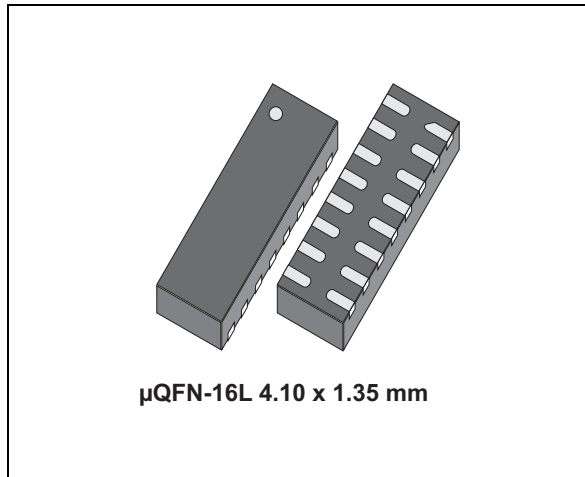
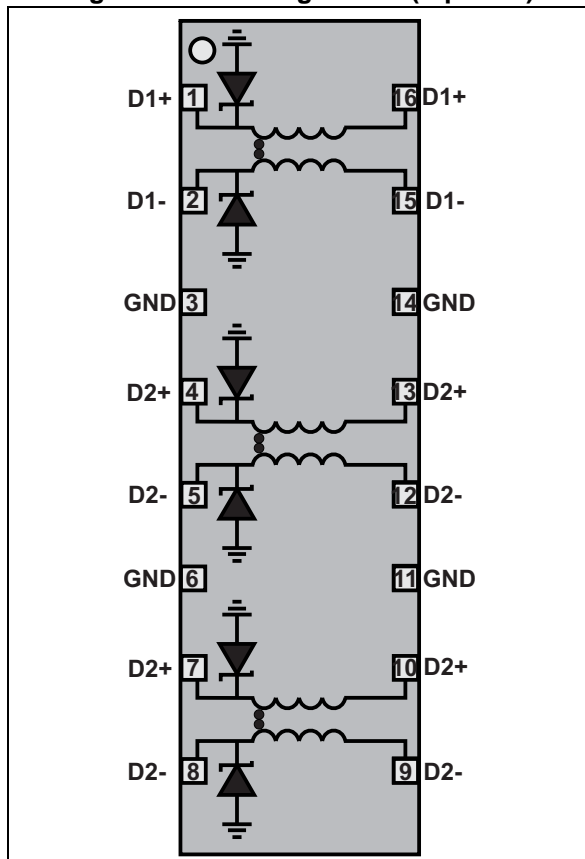

Figure 1. Pin configuration (top view)



Features

- Very large differential bandwidth to comply with HDMI Full HD, MIPI, USB2.0, USB3.0, Display Port and other high speed serial interfaces
- Provides -20 dB attenuation at 700 MHz in LTE bands
- High common mode attenuation: -25 dB between 800 MHz - 900 MHz
- Very low PCB space consumption
- Thin package: 0.55 mm max.
- Lead-free package
- High reduction of parasitic elements through integration.

Complies with the following standards:

- IEC 61000-4-2 level 4:
 - ±15 kV (air discharge)
 - ±8 kV (contact discharge)

Applications

- Mobile phones
- Notebook, laptop
- Portable devices
- PND

Description

This device is a highly integrated common mode filter designed to suppress EMI/RFI common mode noise on high speed differential serial buses like HDMI Full HD, MIPI, Display Port and other high speed serial interfaces. The device has a very large differential bandwidth to comply with these standards. The device can protect and filter 3 differential lanes.

1 Characteristics

Table 1. Absolute maximum ratings ($T_{amb} = 25\text{ °C}$)

Symbol	Parameter		Value	Unit
V_{PP}	Peak pulse voltage	IEC 61000-4-2		
		Contact discharge (connector side)	8	kV
		Air discharge (connector side)	16	
I_{DC}	Maximum DC current		100	mA
T_{op}	Operating temperature range		-40 to +85	°C
T_j	Maximum junction temperature		125	°C
T_{stg}	Storage temperature range		- 55 to +150	°C

Figure 2. Electrical characteristics (definitions)

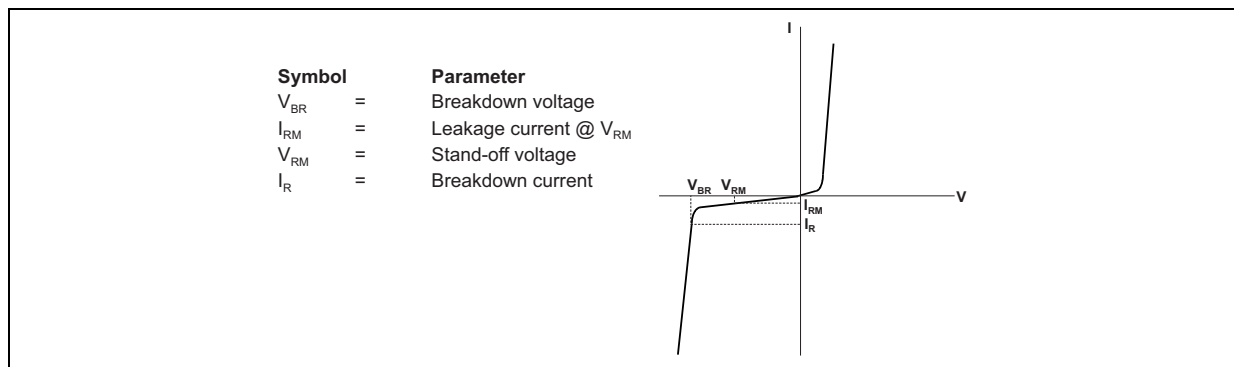

Table 2. Electrical characteristics ($T_{amb} = 25\text{ °C}$)

Symbol	Test conditions	Min.	Typ.	Max.	Unit
V_{BR}	$I_R = 1\text{ mA}$	6			V
I_{RM}	$V_{RM} = 3\text{ V per line}$			100	nA
R_{DC}	DC serial resistance		5		Ω

Table 3. Pin description

Pin number	Description	Pin number	Description	Pin number	Description	Pin number	Description
1	D1+ to connector	5	D2- to connector	9	D3- to IC	13	D2+ to IC
2	D1- to connector	6	GND	10	D3+ to IC	14	GND
3	GND	7	D3+ to connector	11	GND	15	D1- to IC
4	D2+ to connector	8	D3- to connector	12	D2- to IC	16	D1+ to IC

Figure 3. Differential attenuation versus frequency ($Z_{0\text{ diff}} = 100 \Omega$)

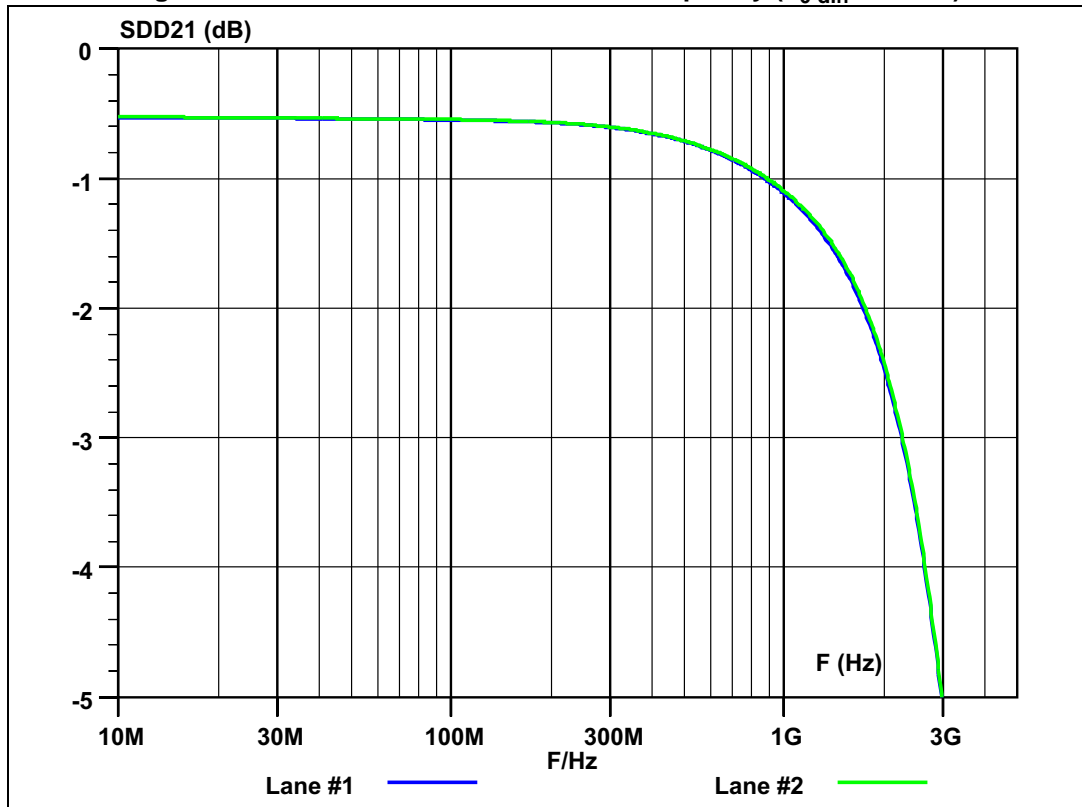

Figure 4. Common mode attenuation versus frequency ($Z_{0\text{ com}} = 50 \Omega$)

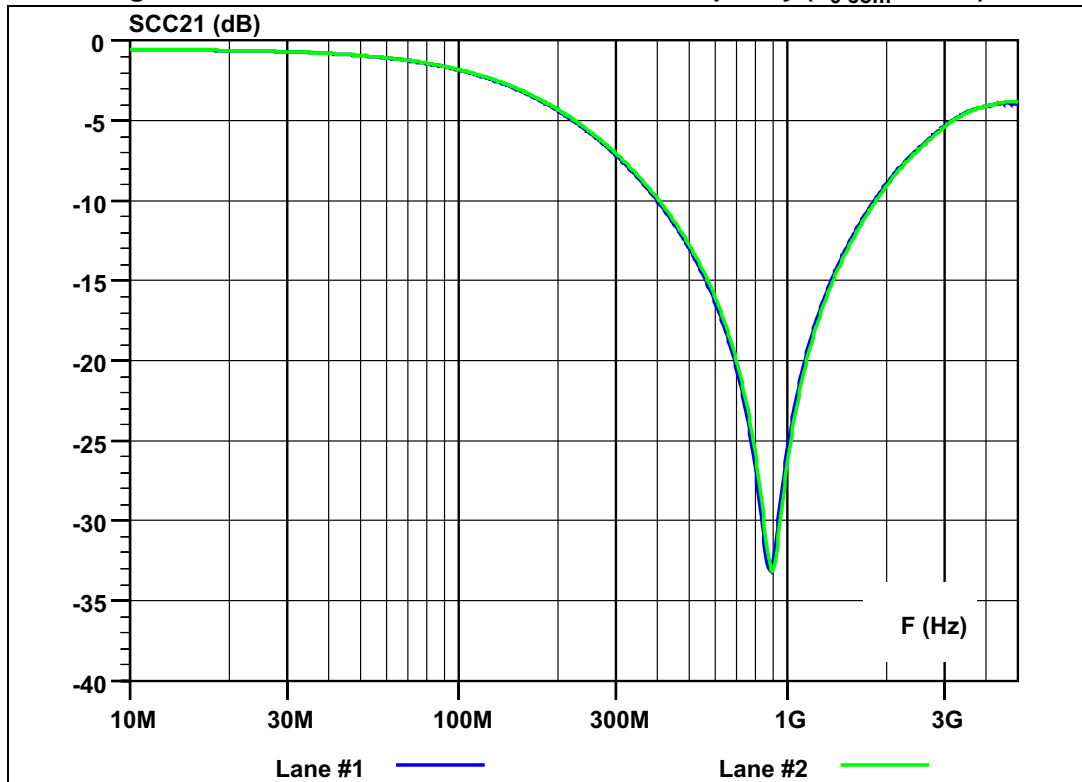

Figure 5. Differential (Z_{DD21}) and common mode (Z_{CC21}) impedance versus frequency

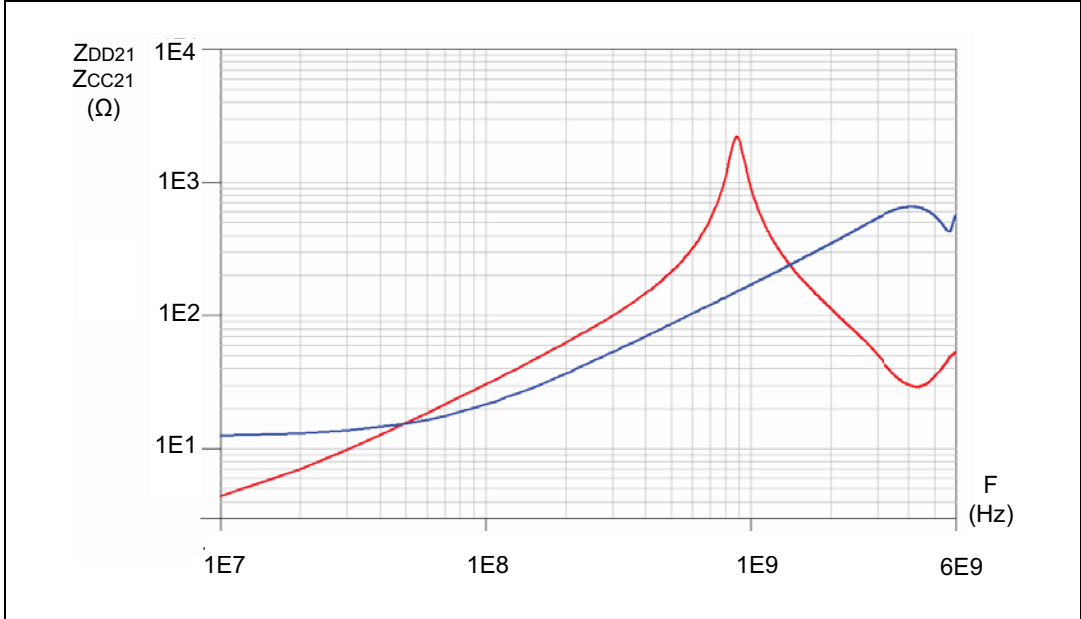

Figure 6. ESD response to IEC61000-4-2 (+8 kV contact discharge)

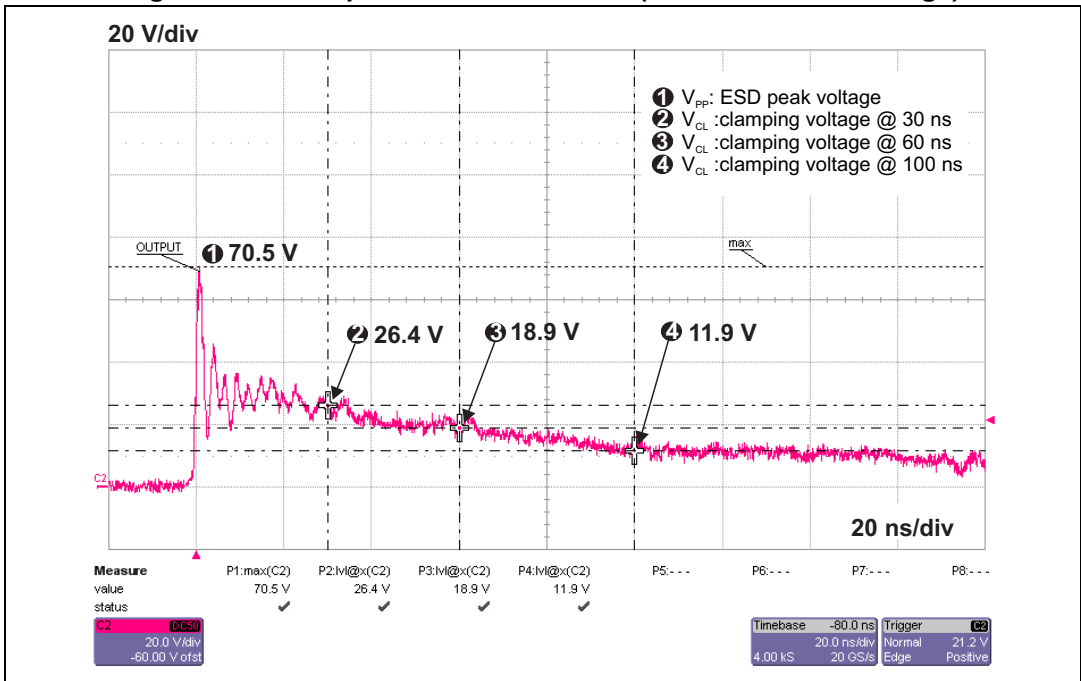

Figure 7. ESD response to IEC61000-4-2 (-8 kV contact discharge)

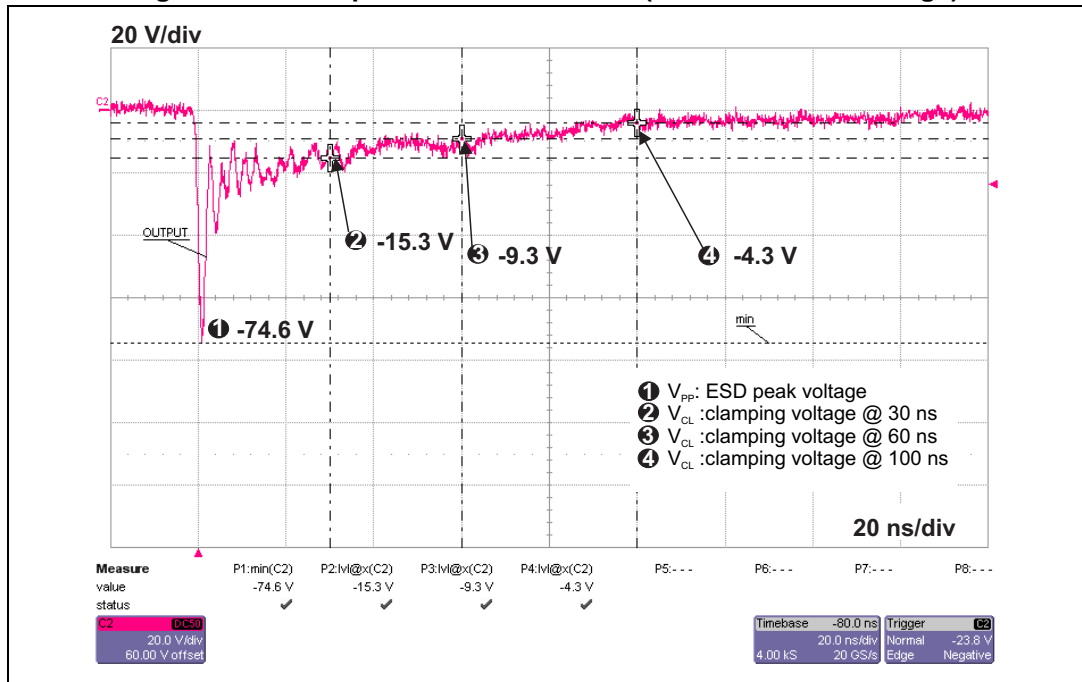

Figure 8. USB2.0 480 Mbps eye diagram without device

Figure 9. USB2.0 480 Mbps eye diagram with device

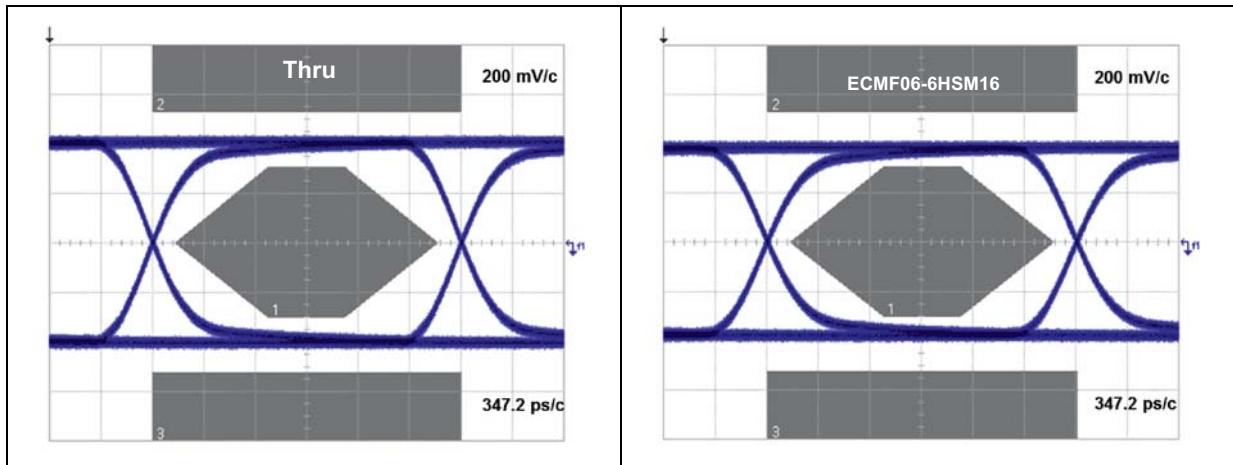

Figure 10. USB3.0 5 Gbps eye diagram without device

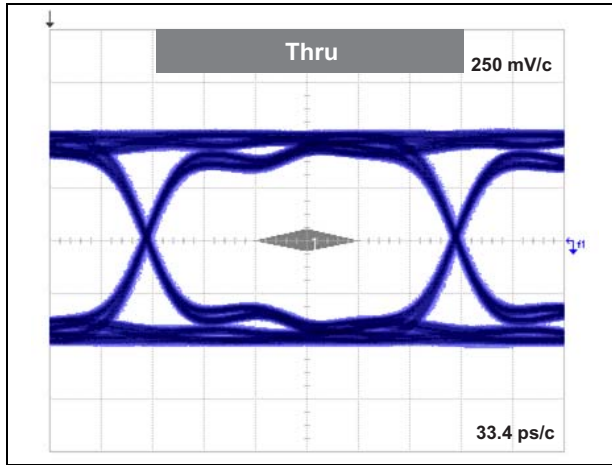

Figure 11. USB3.0 5 Gbps eye diagram with device

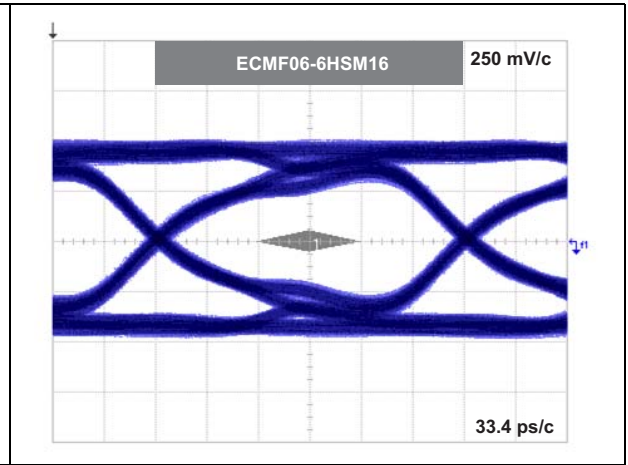

Figure 12. HDMI 3.35 Gbps eye diagram without device

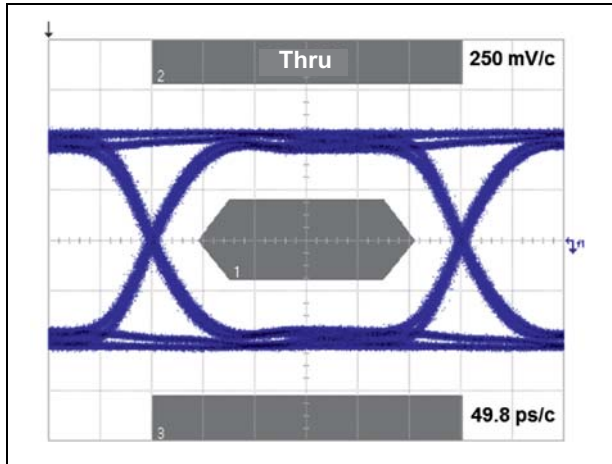

Figure 13. HDMI 3.35 Gbps eye diagram with device

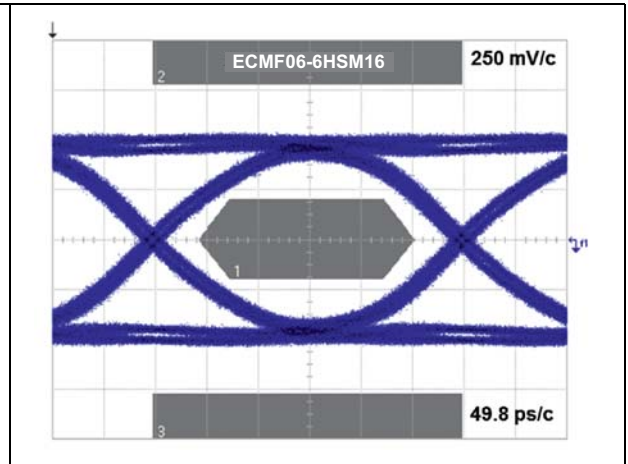
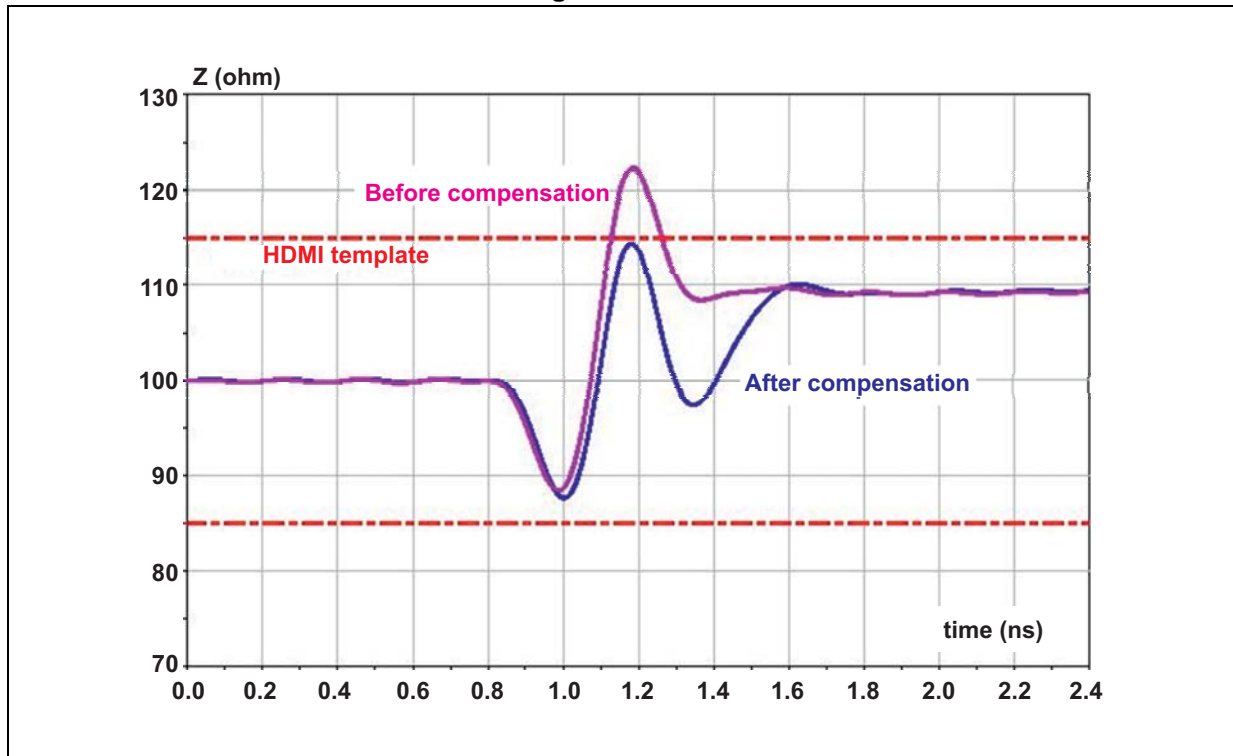
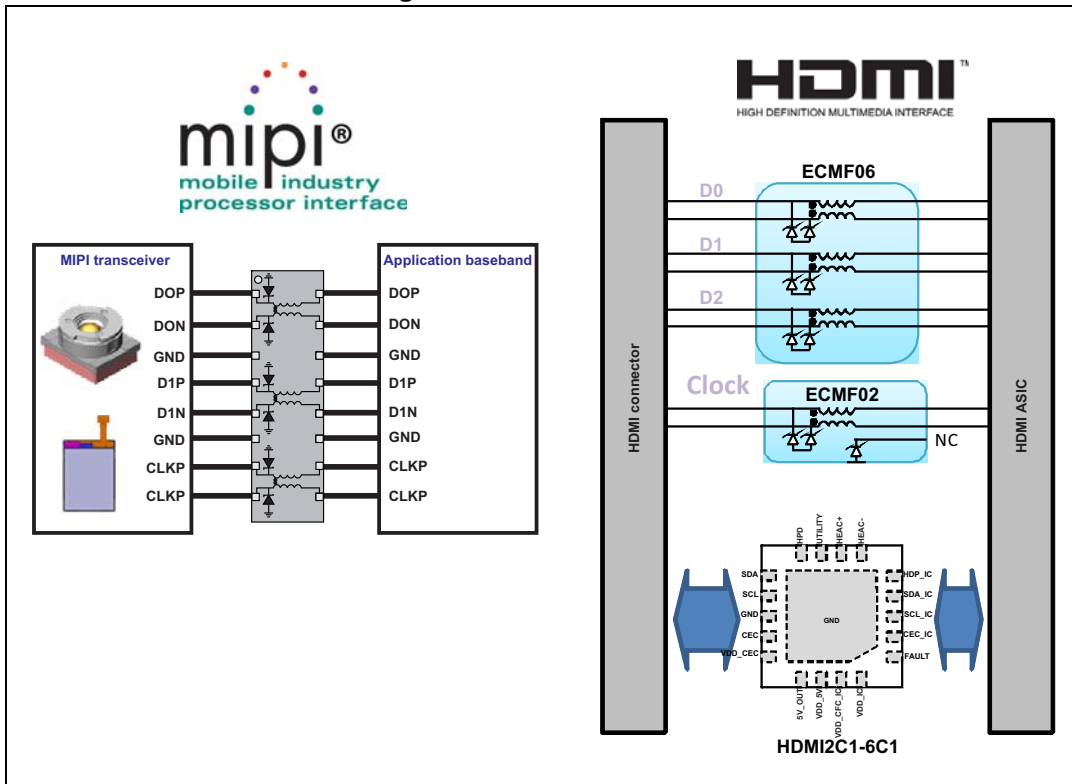

Figure 14. TDR



2 Application information

Figure 15. HDMI schematic



More application information available in following AN:

- Application Note AN4356: "Antenna desense on handheld equipment"
- Application Note AN4511: "Common Mode filters"
- Application Note AN4540: "MHL link filtering and protection"

3 PCB layout recommendations

Figure 16. PCB layout recommendations

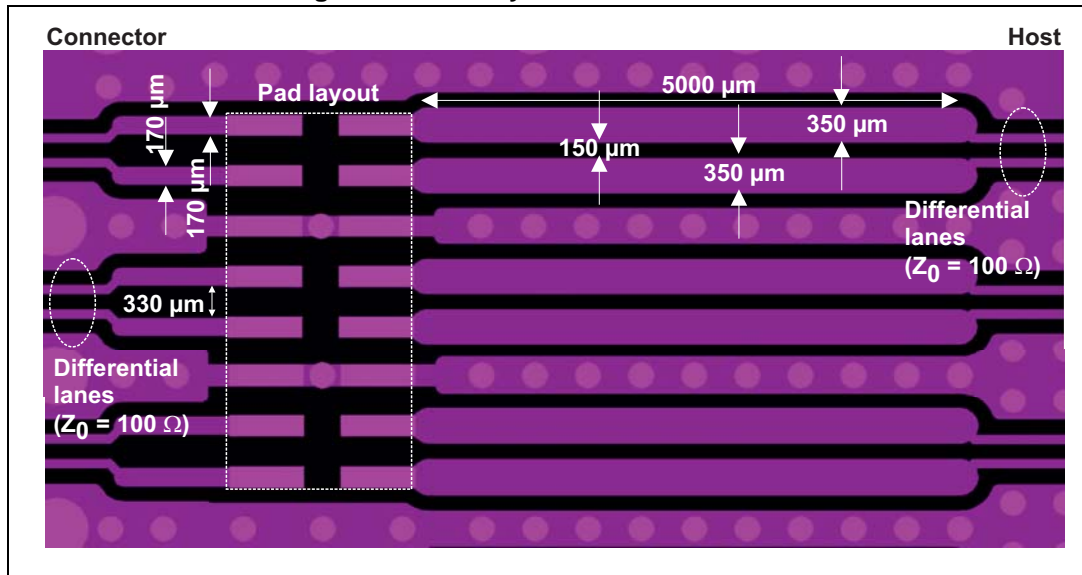
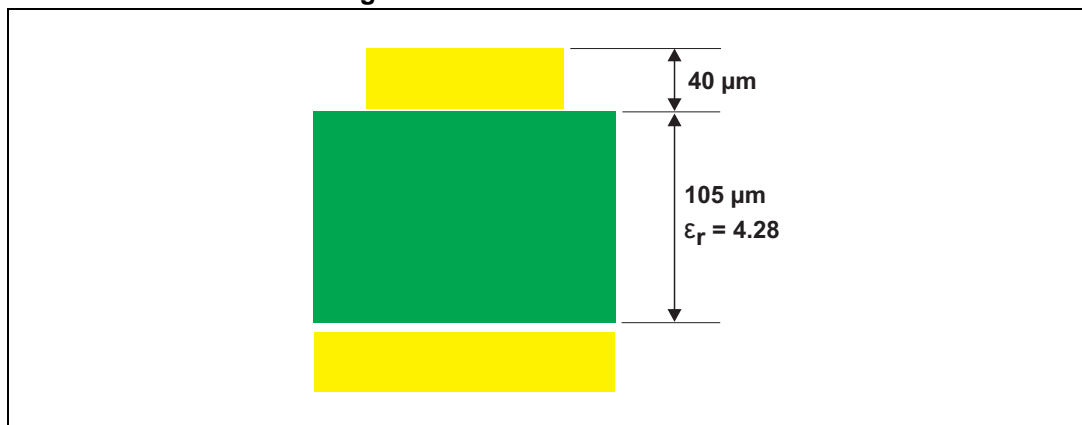

Figure 17. PCB stack dimensions



4 Package information

- Epoxy meets UL94, V0
- Lead-free package

In order to meet environmental requirements, ST offers these devices in different grades of ECOPACK® packages, depending on their level of environmental compliance. ECOPACK® specifications, grade definitions and product status are available at: www.st.com. ECOPACK® is an ST trademark.

Figure 18. μQFN-16L dimension definitions

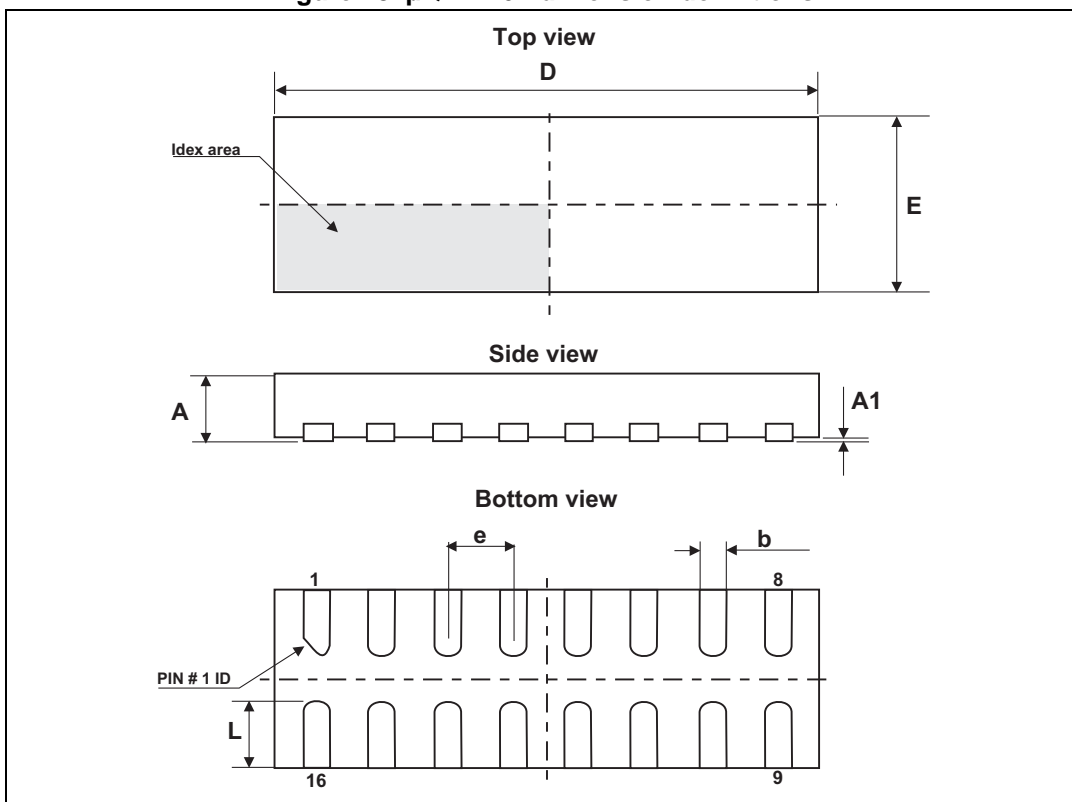

Table 4. μQFN-16L dimension values

Ref.	Dimensions					
	Millimeters			Inches		
	Min.	Typ.	Max.	Min.	Typ.	Max.
A	0.45	0.50	0.55	0.018	0.020	0.022
A1	0.00	0.02	0.05	0.00	0.0008	0.002
b	0.15	0.20	0.25	0.006	0.008	0.010
D		4.10			0.161	
E		1.35			0.053	
e		0.50			0.020	
L	0.40	0.50	0.60	0.016	0.020	0.024

Figure 19. Footprint

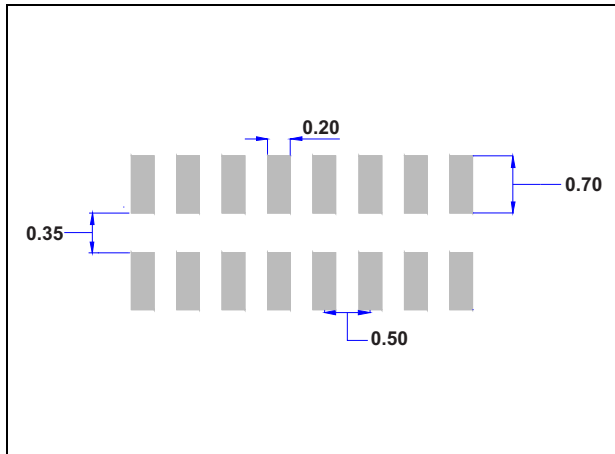

Figure 20. Marking

Dot : Pin 1 Identification
 X X= Marking
 WW= DataCode (week)
 Y=Data code(Year)
 P=Assembly plant

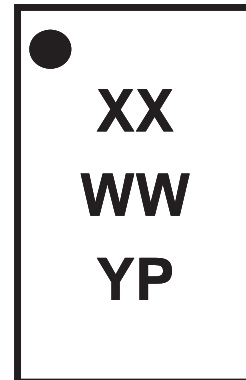
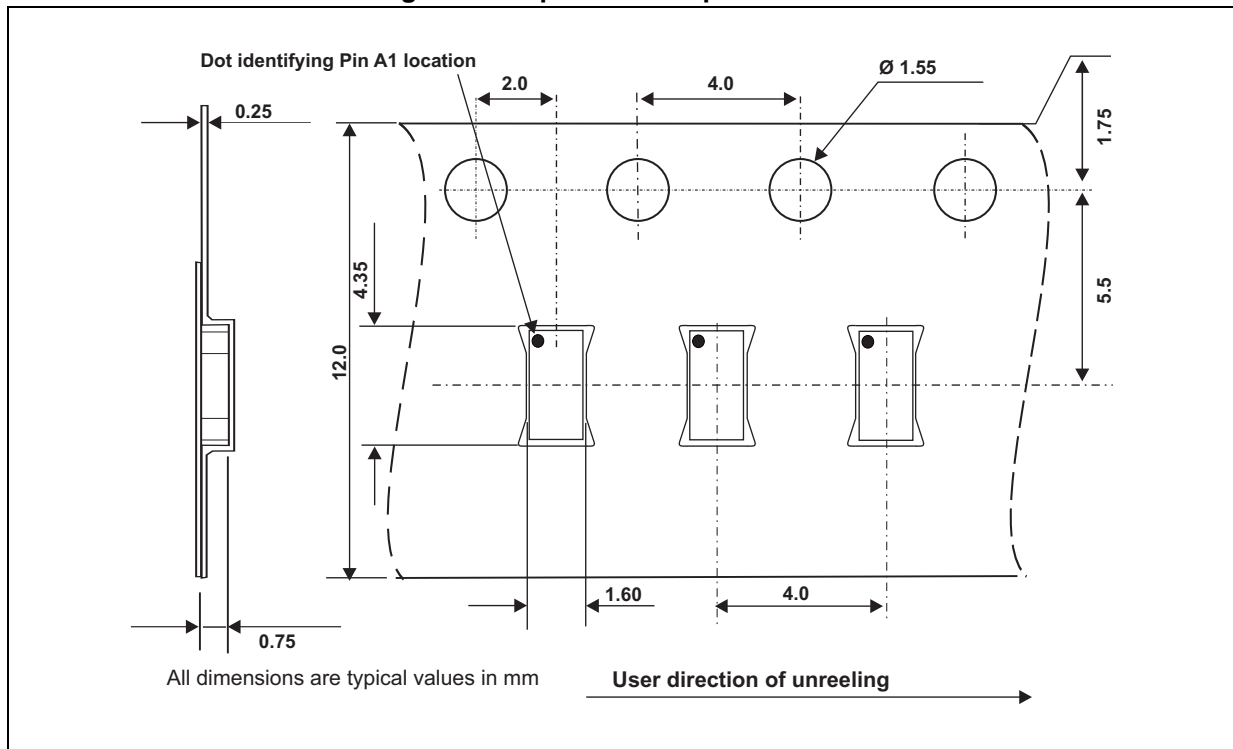

Figure 21. Tape and reel specifications



5 Ordering information

Figure 22. Ordering information scheme

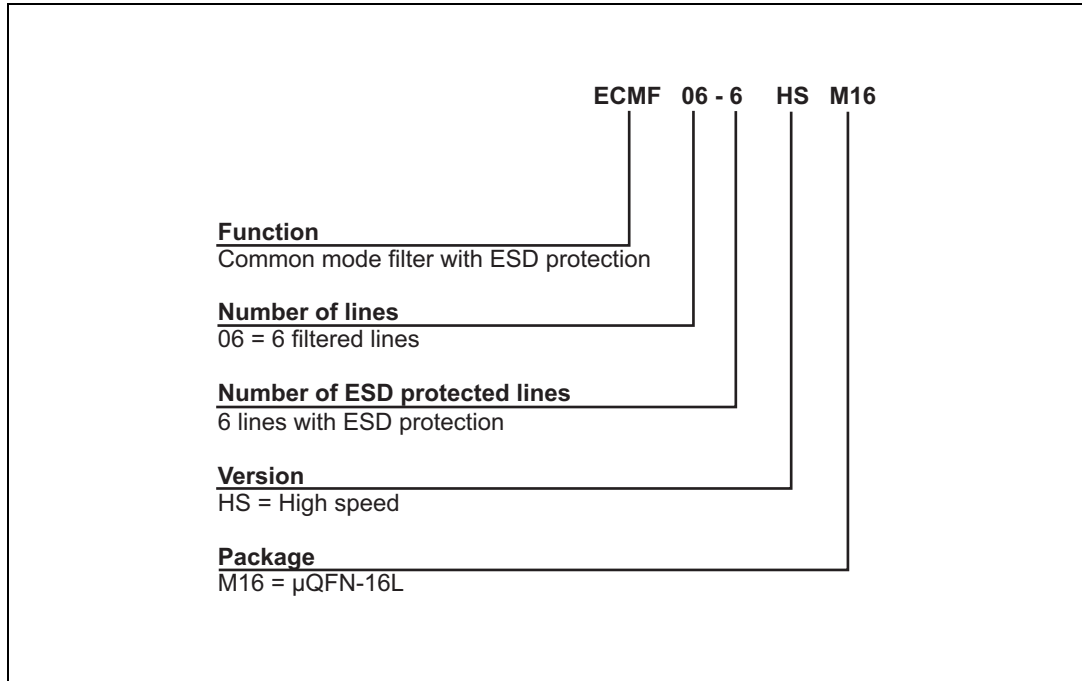

Table 5. Ordering information

Order code	Marking	Package	Weight	Base qty	Delivery mode
ECMF06-6HSM16	KL	μ QFN-16L	7.76 mg	3000	Tape and reel

6 Revision history

Table 6. Document revision history

Date	Revision	Changes
03-Oct-2013	1	Initial release.
25-Aug-2014	2	Added <i>Figure 5: Differential (ZDD21) and common mode (ZCC21) impedance versus frequency.</i>

IMPORTANT NOTICE – PLEASE READ CAREFULLY

STMicroelectronics NV and its subsidiaries ("ST") reserve the right to make changes, corrections, enhancements, modifications, and improvements to ST products and/or to this document at any time without notice. Purchasers should obtain the latest relevant information on ST products before placing orders. ST products are sold pursuant to ST's terms and conditions of sale in place at the time of order acknowledgement.

Purchasers are solely responsible for the choice, selection, and use of ST products and ST assumes no liability for application assistance or the design of Purchasers' products.

No license, express or implied, to any intellectual property right is granted by ST herein.

Resale of ST products with provisions different from the information set forth herein shall void any warranty granted by ST for such product.

ST and the ST logo are trademarks of ST. All other product or service names are the property of their respective owners.

Information in this document supersedes and replaces information previously supplied in any prior versions of this document.

© 2014 STMicroelectronics – All rights reserved





Компания «ЭлектроПласт» предлагает заключение долгосрочных отношений при поставках импортных электронных компонентов на взаимовыгодных условиях!

Наши преимущества:

- Оперативные поставки широкого спектра электронных компонентов отечественного и импортного производства напрямую от производителей и с крупнейших мировых складов;
- Поставка более 17-ти миллионов наименований электронных компонентов;
- Поставка сложных, дефицитных, либо снятых с производства позиций;
- Оперативные сроки поставки под заказ (от 5 рабочих дней);
- Экспресс доставка в любую точку России;
- Техническая поддержка проекта, помощь в подборе аналогов, поставка прототипов;
- Система менеджмента качества сертифицирована по Международному стандарту ISO 9001;
- Лицензия ФСБ на осуществление работ с использованием сведений, составляющих государственную тайну;
- Поставка специализированных компонентов (Xilinx, Altera, Analog Devices, Intersil, Interpoint, Microsemi, Aeroflex, Peregrine, Syfer, Eurofarad, Texas Instrument, Miteq, Cobham, E2V, MA-COM, Hittite, Mini-Circuits, General Dynamics и др.);

Помимо этого, одним из направлений компании «ЭлектроПласт» является направление «Источники питания». Мы предлагаем Вам помощь Конструкторского отдела:

- Подбор оптимального решения, техническое обоснование при выборе компонента;
- Подбор аналогов;
- Консультации по применению компонента;
- Поставка образцов и прототипов;
- Техническая поддержка проекта;
- Защита от снятия компонента с производства.



Как с нами связаться

Телефон: 8 (812) 309 58 32 (многоканальный)

Факс: 8 (812) 320-02-42

Электронная почта: org@eplast1.ru

Адрес: 198099, г. Санкт-Петербург, ул. Калинина, дом 2, корпус 4, литера А.