

# HEDM-55xx/560x & HEDS-55xx/56xx

## Quick Assembly Two and Three Channel Optical Encoders



## Data Sheet



### Description

The HEDS-5500/5540, HEDS-5600/5640, HEDM-5500/5540 and HEDM-5600 are high performance, low cost, two and three channel optical incremental encoders. These encoders emphasize high reliability, high resolution, and easy assembly.

Each encoder contains a lensed LED source, an integrated circuit with detectors and output circuitry, and a codewheel which rotates between the emitter and detector IC. The outputs of the HEDS-5500/5600 and HEDM-5500/5600 are two square waves in quadrature. The HEDS-5540/5640 and HEDM-5540 also have a third channel index output in addition to the two channel quadrature. This index output is a 90 electrical degree, high true index pulse which is generated once for each full rotation of the codewheel.

The HEDS series utilizes metal codewheels, while the HEDM series utilizes a film codewheel allowing for resolutions to 1024 CPR.

These encoders may be quickly and easily mounted to a motor. For larger diameter motors, the HEDM-5600, and HEDS-5600/5640 feature external mounting ears.

The quadrature signals and the index pulse are accessed through five 0.025 inch square pins located on 0.1 inch centers.

Standard resolutions between 96 and 1024 counts per revolution are presently available. Consult local Avago sales representatives for other resolutions.

### Features

- Two channel quadrature output with optional index pulse
- Quick and easy assembly
- No signal adjustment required
- External mounting ears available
- Low cost
- Resolutions up to 1024 counts per revolution
- Small size –40°C to 100°C operating temperature
- TTL compatible
- Single 5 V supply

### Applications

The HEDS-5500, 5540, 5600, 5640, and the HEDM-5500, 5540, 5600 provide motion detection at a low cost, making them ideal for high volume applications. Typical applications include printers, plotters, tape drives, positioning tables, and automatic handlers.

Note: Avago Technologies encoders are not recommended for use in safety critical applications. Eg. ABS braking systems, power steering, life support systems and critical care medical equipment. Please contact sales representative if more clarification is needed.

**ESD WARNING:** NORMAL HANDLING PRECAUTIONS SHOULD BE TAKEN TO AVOID STATIC DISCHARGE.

## Package Dimensions

### HEDS-5500/5540, HEDM-5500/5540

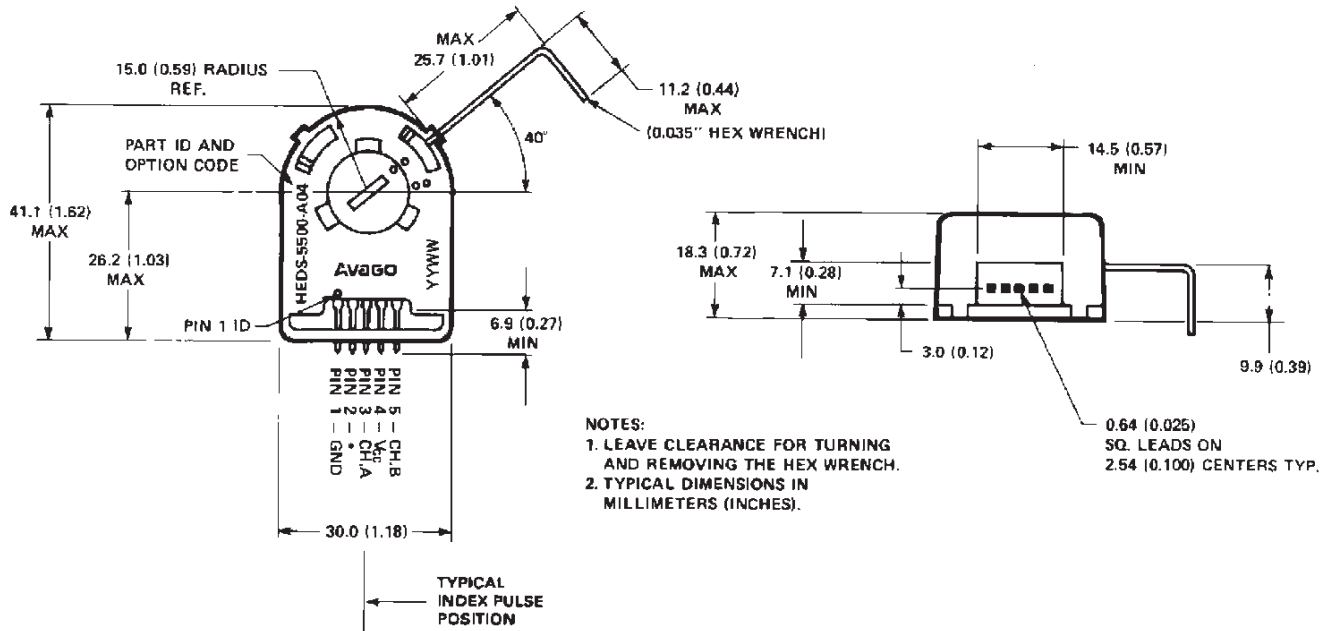

**\*Notes:**

For the HEDS-5500 and HEDM-5500, Pin #2 is a No Connect.  
 For the HEDS-5540 and HEDM-5540, Pin #2 is CH. I, the index output.

### HEDS-5600/5640, HEDM-5600, HEDM-5640



**\*Notes:**

For the HEDS-5600 and HEDM-5600, Pin #2 is a No Connect.  
 For the HEDS-5640 and HEDM-5640, Pin #2 is CH. I, the index output.

## Theory of Operation

The HEDS-5500/5540, HEDS-5600/5640, HEDM-5500/5540 and HEDM-5600 translate the rotary motion of a shaft into either a two- or a three-channel digital output.

As seen in the block diagram, these encoders contain a single Light Emitting Diode (LED) as its light source. The light is collimated into a parallel beam by means of a single polycarbonate lens located directly over the LED. Opposite the emitter is the integrated detector circuit. This IC consists of multiple sets of photodetectors and the signal processing circuitry necessary to produce the digital waveforms.

The codewheel rotates between the emitter and detector, causing the light beam to be interrupted by the pattern of spaces and bars on the codewheel. The photodiodes which detect these interruptions are arranged in a pattern that corresponds to the radius and design of the codewheel. These detectors are also spaced such that a light period on one pair of detectors corresponds to a dark period on the adjacent pair of detectors. The photodiode outputs are then fed through the signal processing circuitry resulting in A,  $\bar{A}$ , B and  $\bar{B}$  (also I and  $\bar{I}$  in the HEDS-5540/5640 and HEDM-5540). Comparators receive these signals and produce the final outputs for channels A and B. Due to this integrated phasing technique, the digital output of channel A is in quadrature with that of channel B (90 degrees out of phase).

In the HEDS-5540/5640 and HEDM-5540, the output of the comparator for I and  $\bar{I}$  is sent to the index processing circuitry along with the outputs of channels A and B.

The final output of channel I is an index pulse PO which is generated once for each full rotation of the codewheel. This output PO is a one state width (nominally 90 electrical degrees), high true index pulse which is coincident with the low states of channels A and B.

## Block Diagram



Note: Circuitry for CH I is only for HEDS-5540/5640, HEDM-5540/5540 Three Channel Encoder

## Definitions

**Count (N):** The number of bar and window pairs or counts per revolution (CPR) of the codewheel.

**One Cycle (C):** 360 electrical degrees ( $^{\circ}$ e), 1 bar and window pair.

**One Shaft Rotation:** 360 mechanical degrees, N cycles.

**Position Error ( $\Delta\theta$ ):** The normalized angular difference between the actual shaft position and the position indicated by the encoder cycle count.

**Cycle Error ( $\Delta C$ ):** An indication of cycle uniformity. The difference between an observed shaft angle which gives rise to one electrical cycle, and the nominal angular increment of  $1/N$  of a revolution.

**Pulse Width (P):** The number of electrical degrees that an output is high during 1 cycle. This value is nominally  $180^{\circ}$ e or  $1/2$  cycle.

**Pulse Width Error ( $\Delta P$ ):** The deviation, in electrical degrees, of the pulse width from its ideal value of  $180^{\circ}$ e.

**State Width (S):** The number of electrical degrees between a transition in the output of channel A and the neighbouring transition in the output of channel B. There are 4 states per cycle, each nominally  $90^{\circ}$ e.

**State Width Error ( $\Delta S$ ):** The deviation, in electrical degrees, of each state width from its ideal value of  $90^{\circ}$ e.

**Phase ( $\phi$ ):** The number of electrical degrees between the center of the high state of channel A and the center of the high state of channel B. This value is nominally  $90^{\circ}$ e for quadrature output.

**Phase Error ( $\Delta\phi$ ):** The deviation of the phase from its ideal value of  $90^{\circ}$ e.

**Direction of Rotation:** When the codewheel rotates in the counter-clockwise direction (as viewed from the encoder end of the motor), channel A will lead channel B. If the codewheel rotates in the clockwise direction, channel B will lead channel A.

**Index Pulse Width ( $P_0$ ):** The number of electrical degrees that an index output is high during one full shaft rotation. This value is nominally  $90^{\circ}$ e or  $1/4$  cycle.

## Absolute Maximum Ratings

Parameter	HEDS-55XX/56XX	HEDM-550X/560X	HEDM-5540/5640
Storage Temperature, $T_S$	-40°C to 100°C	-40°C to +70°C	-40°C to 85°C
Operating Temperature, $T_A$	-40°C to 100°C	-40°C to +70°C	-40°C to 85°C
Supply Voltage, $V_{CC}$	-0.5 V to 7 V	-0.5 V to 7 V	-0.5 V to 7 V
Output Voltage, $V_O$	-0.5 V to VCC	-0.5 V to VCC	-0.5 V to VCC
Output Current per Channel, $I_{OUT}$	-1.0 mA to 5 mA	-1.0 mA to 5 mA	-1.0 mA to 5 mA
Vibration	20 g, 5 to 1000 Hz	20 g, 5 to 1000 Hz	20 g, 5 to 1000 Hz
Shaft Axial Play	± 0.25 mm (± 0.010 in.)	± 0.175 mm (± 0.007 in.)	± 0.175 mm (± 0.007 in.)
Shaft Eccentricity Plus Radial Play	0.1 mm (0.004 in.) TIR	0.04 mm (0.0015 in.) TIR	0.04 mm (0.0015 in.) TIR
Velocity	30,000 RPM	30,000 RPM	30,000 RPM
Acceleration	250,000 rad/sec <sup>2</sup>	250,000 rad/sec <sup>2</sup>	250,000 rad/sec <sup>2</sup>

## Output Waveforms



## Recommended Operating Conditions

Parameter		Sym.	Min.	Typ.	Max.	Units	Notes
Temperature HEDS Series		T <sub>A</sub>	-40		100	°C	
Temperature HEDM Series	5500/5600	T <sub>A</sub>	-40		70	°C	non-condensing atmosphere
	5540/5640	T <sub>A</sub>	-40		85	°C	
Supply Voltage		V <sub>CC</sub>	4.5	5.0	5.5	Volts	Ripple < 100 mVp-p
Load Capacitance		C <sub>L</sub>			100	pF	2.7 kΩ pull-up
Count Frequency		f			100	kHz	Velocity (rpm) x N/60
Shaft Perpendicularity Plus Axial Play (HEDS Series)					± 0.25 (±0.010)	mm (in.)	6.9 mm (0.27 in.) from mounting surface
Shaft Eccentricity Plus Radial Play (HEDS Series)					0.04 (0.0015)	mm (in.) TIR	6.9 mm (0.27 in.) from mounting surface
Shaft Perpendicularity Plus Axial Play (HEDM Series)					± 0.175 (±0.007)	mm (in.)	6.9 mm (0.27 in.) from mounting surface
Shaft Eccentricity Plus Radial Play (HEDM Series)					0.04 (0.0015)	mm (in.) TIR	6.9 mm (0.27 in.) from mounting surface

Note: The module performance is guaranteed to 100 kHz but can operate at higher frequencies. 2.7 kΩ pull-up resistors required for HEDS-5540/5640 and HEDM-5540/5640.

## Encoding Characteristics

Part No.	Description	Sym.	Min	Typ.*	Max.	Units	
HEDS-5500	Pulse Width Error	ΔP		7	45	°e	
HEDS-5600 (Two Channel)	Logic State Width Error	ΔS		5	45	°e	
	Phase Error	ΔΦ		2	20	°e	
	Position Error	ΔΘ		10	40	min. of arc	
	Cycle Error	ΔC		3	5.5	°e	
HEDM-5500	Pulse Width Error	ΔP		10	45	°e	
HEDM-5600 (Two Channel)	Logic State Width Error	ΔS		10	45	°e	
	Phase Error	ΔΦ		2	15	°e	
	Position Error	ΔΘ		10	40	min. of arc	
	Cycle Error	ΔC		3	7.5	°e	
HEDS-5540	Pulse Width Error	ΔP		5	45	°e	
HEDS-5640 (Three Channel)	Logic State Width Error	ΔS		5	35	°e	
	Phase Error	ΔΦ		2	15	°e	
	Position Error	ΔΘ		10	40	min. of arc	
	Cycle Error	ΔC		3	5.5	°e	
	Index Pulse Width	P <sub>o</sub>	55	90	125	°e	
	CH.I rise after CH.A or CH. B fall	t <sub>1</sub>	-40°C to +100°C	-300	100	250	ns
	CH.I fall after CH.A or CH. B rise	t <sub>2</sub>	-40°C to +100°C	70	150	1000	ns
HEDM-5540	Pulse Width Error	ΔP		10	45	°e	
HEDM-5640 (Three Channel)	Logic State Width Error	ΔS		10	45	°e	
	Phase Error	ΔΦ		2	15	°e	
	Position Error	ΔΘ		10	40	min. of arc	
	Cycle Error	ΔC		6	12	°e	
	Index Pulse Width	P <sub>o</sub>	50	90	130	°e	
	CH.I rise after CH.A or CH. B fall	t <sub>1</sub>	-40°C to +85°C	200	1000	1500	ns
	CH.I fall after CH.A or CH. B rise	t <sub>2</sub>	-40°C to +85°C	0	300	1500	ns

Note: See Mechanical Characteristics for mounting tolerances. \*Typical values specified at V<sub>CC</sub> = 5.0 V and 25°C.

## Electrical Characteristics

Electrical Characteristic over Recommended Operating Range

Part No.	Parameter	Sym.	Min	Typ.*	Max.	Units	Notes
HEDS-5500	Supply Current	$I_{CC}$		17	40	mA	
HEDS-5600	High Level Output Voltage	$V_{OH}$	2.4			V	$I_{OH} = -40\mu\text{A max}$
	Low Level Output Voltage	$V_{OL}$			0.4	V	$I_{OL} = 3.2\text{mA}$
	Rise Time	$t_r$		200		ns	$C_L = 25\text{ pF}$
	Fall Time	$t_f$		50		ns	$R_L = 11\text{ k}\Omega\text{ pull-up}$
HEDS-5540	Supply Current	$I_{CC}$	30	57	85	mA	
HEDS-5640	High Level Output Voltage	$V_{OH}$	2.4			V	$I_{OH} = -200\mu\text{A max}$
HEDM-5500	Low Level Output Voltage	$V_{OL}$			0.4	V	$I_{OL} = 3.86\text{mA}$
HEDM-5600	Rise Time	$t_r$		180		ns	$C_L = 25\text{ pF}$
	Fall Time	$t_f$		40		ns	$R_L = 2.7\text{ k}\Omega\text{ pull-up}$
HEDM-5500	Supply Current	$I_{CC}$	30	57	85	mA	
HEDM-5600	High Level Output Voltage	$V_{OH}$	2.4			V	$I_{OH} = -40\mu\text{A max}$
	Low Level Output Voltage	$V_{OL}$			0.4	V	$I_{OL} = 3.86\text{mA}$
	Rise Time	$t_r$		180		ns	$C_L = 25\text{ pF}$
	Fall Time	$t_f$		40		ns	$R_L = 3.2\text{ k}\Omega\text{ pull-up}$
HEDM-5540	Supply Current	$I_{CC}$	30	57	85	mA	
HEDM-5640	High Level Output Voltage	$V_{OH}$	2.4			V	$I_{OH} = -200\mu\text{A max}$
	Low Level Output Voltage	$V_{OL}$			0.4	V	$I_{OL} = 3.86\text{mA}$
	Rise Time	$t_r$		200		ns	$C_L = 25\text{ pF}$
	Fall Time	$t_f$		80		ns	$R_L = 2.7\text{ k}\Omega\text{ pull-up}$

\* Typical values specified at  $V_{CC} = 5.0\text{V}$  and  $25^\circ\text{C}$

## Mechanical Characteristics

Parameter	Symbol	Dimension	Tolerance <sup>[1]</sup>	Units
Codewheel Fits These Standard Shaft Diameters		2 3 4	+0.000	mm
		5 6 8	-0.015	
		5/32 1/8	+0.0000	in
		3/16 1/4	-0.0007	
Moment of Inertia	J	0.6 (8.0 x 10 <sup>-6</sup> )		g-cm <sup>2</sup> (oz-in-s <sup>2</sup> )
Required Shaft Length <sup>[2]</sup>		14.0 (0.55)	± 0.5 (± 0.02)	mm (in.)
Bolt Circle <sup>[3]</sup>	2 screw mounting	19.05 (0.750)	± 0.13 (± 0.005)	mm (in.)
	3 screw mounting	20.90 (0.823)	± 0.13 (± 0.005)	mm (in.)
	external mounting ears	46.0 (1.811)	± 0.13 (± 0.005)	mm (in.)
Mounting Screw Size <sup>[4]</sup>	2 screw mounting	M 2.5 or (2-56)		mm (in.)
	3 screw mounting	M 1.6 or (0-80)		mm (in.)
	external mounting ears	M 2.5 or (2-56)		mm (in.)
Encoder Base Plate Thickness		0.33 (0.130)		mm (in.)
Hub Set Screw		(2-56)		(in.)

### Notes:

1. These are tolerances required of the user.
2. The HEDS-55x5 and 56x5, HEDM-5505, 5605 provide an 8.9 mm (0.35 inch) diameter hole through the housing for longer motor shafts. See Ordering Information.
3. The HEDS-5540 and 5640 must be aligned using the aligning pins as specified in Figure 3, or using the alignment tool as shown in "Encoder Mounting and Assembly". See also "Mounting Considerations."
4. The recommended mounting screw torque for 2 screw and external ear mounting is 1.0 kg-cm (0.88 in-lbs). The recommended mounting screw torque for 3 screw mounting is 0.50 kg-cm (0.43 in-lbs).

## Electrical Interface

To insure reliable encoding performance, the HEDS-5540/5640 and HEDM-5540 three channel encoders require 2.7 kΩ (± 10%) pull-up resistors on output pins 2, 3, and 5 (Channels I, A, and B) as shown in Figure 1. These pull-up resistors should be located as close to the encoder as possible (within 4 feet). Each of the three encoder outputs can drive a single TTL load in this configuration. The HEDS-5500, 5600, and HEDM-5500, 5600 two channel encoders do not normally require pull-up resistors. However, 3.2 kΩ pull-up resistors on output pins 3 and 5 (Channels A and B) are recommended to improve rise times, especially when operating above 100 kHz frequencies.

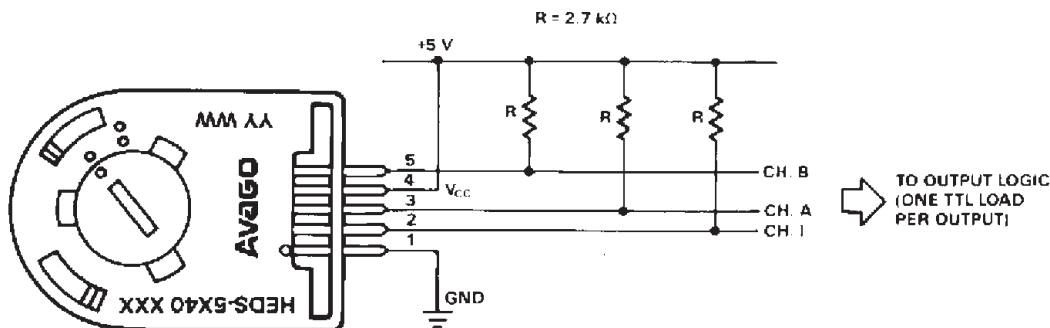

Figure 1. Pull-up Resistors on HEDS-5x40 and HEDM-5540 Encoder Outputs.

## Mounting Considerations

The HEDS-5540 and 5640 three channel encoders and the HEDM Series high resolution encoders must be aligned using the aligning pins as specified in Figure 3, or using the HEDS-8910 Alignment Tool as shown in Encoder Mounting and Assembly.

The use of aligning pins or alignment tool is recommended but not required to mount the HEDS-5500 and 5600. If these two channel encoders are attached to a motor with the screw sizes and mounting tolerances specified in the mechanical characteristics section without any additional mounting bosses, the encoder output errors will be within the maximums specified in the encoding characteristics section. The HEDS-5500 and 5540 can be mounted to a motor using either the two screw or three screw mounting option as shown in Figure 2. The optional aligning pins shown in Figure 3 can be used with either mounting option. The HEDS-5600, 5640, and HEDM-5600 have external mounting ears which may be used for mounting to larger motor base plates. Figure 4 shows the necessary mounting holes with optional aligning pins and motor boss.



Figure 2. Mounting Holes.



Figure 3. Optional Mounting Aids.



Figure 4. Mounting with External Ears.



## Encoder Mounting and Assembly

- 1a. For HEDS-5500 and 5600: Mount encoder base plate onto motor. Tighten screws. Go on to step 2.
  - 1b. For HEDS-5540, 5640 and HEDM-5500, 5600, 5540 : Slip alignment tool onto motor shaft. With alignment tool in place, mount encoder baseplate onto motor as shown above. Tighten screws. Remove alignment tool.
  - 1c. It is recommended that adhesive\* is applied to the screw-baseplate interface to prevent screw loosening due to effect of high temperature on plastic
  2. Snap encoder body onto base plate locking all 4 snaps.
  - 3a. Push the hex wrench into the body of the encoder to ensure that it is properly seated into the code wheel hub set screws. Then apply a downward force on the end of the hex wrench. This sets the code wheel gap by levering the code wheel hub to its upper position.
  - 3b. While continuing to apply a downward force, rotate the hex wrench in the clockwise direction until the hub set screw is tight against the motor shaft (The recommended torque to tighten the setscrew is 15-18 ozf.inch). The hub set screw attaches the code wheel to the motor's shaft.
  - 3c. Remove the hex wrench by pulling it straight out of the encoder body.
  4. Use the center screwdriver slot, or either of the two side slots, to rotate the encoder cap dot clockwise from the one dot position to the two dot position. Do not rotate the encoder cap counterclockwise beyond the one dot position.
- The encoder is ready for use!



## Connectors

Manufacturer	Part Number
AMP	103686-4 640442-5
Avago (designed to mechanically lock into the HEDS-5XXX, HEDM-5X0X Series)	HEDS-8902 (2 ch.) with 4-wire leads HEDS-8903 (3 ch.) with 5-wire leads
Molex	2695 series with 2759 series term. Single ended cable connector P/N : 0050579405 and P/N : 0016020097.



Figure 5. HEDS-8902 and 8903 connectors

## Protective Silicon Cover

Protective Silicon Rubber cover gives an extra protection for HEDS-5xx0 and HEDM-5xx0 family when operating in dusty environment.

The protective silicon cover is installed to HEDS-5xx0 or HEDM-5xx0 prior to the connector to the encoder is installed.

<b>Part Number</b>	HEDS-8907-001
<b>Material</b>	Silicon Rubber- Semi transparent-ESD protective material
<b>Used With</b>	HEDS-5xx0 and HEDM-5xx0
<b>Temperature Range</b>	-40°C to 100°C



1. Dimensions are in  $\frac{\text{millimeters}}{\text{Inches}}$
2. All tolerances are within  $\pm 0.5$

## Typical Interfaces



## Ordering Information

### Encoders with Film Codewheels



(Included with each order of HEDM-550X/560X two channel encoders and HEDM-554X three Channel encoders)



(Included with each order of HEDS-554X/564X three channel encoders)

		01	02	03	04	05	06	11	12	13	14
HEDM-5500	B	*	*				*	*	*	*	*
	J		*				*		*	*	*
HEDM-5505	B			*							
	J			*			*			*	
HEDM-5540	B	*	*		*			*		*	*
HEDM-5540	M						*				*
HEDM-5545	B									*	
HEDM-5600	B						*			*	
	J						*				
HEDM-5605	B						*				
	J						*				
HEDM-5640	M						*				*
HEDS-5500	A	*	*	*	*	*	*	*	*	*	*
	C	*	*	*	*	*	*	*	*	*	*
	E		*		*	*	*	*	*		*
	F	*	*		*	*	*	*	*		*
	G		*			*	*		*		*
	H					*	*		*		*
	I	*	*	*	*	*	*	*	*	*	*
	K				*	*	*	*			
	S										*
HEDS-5505	A			*		*				*	*
	C			*		*		*		*	*
	E			*		*				*	
	F			*		*				*	
	G			*		*					*
	H					*					*
	I			*		*				*	
	K			*							
HEDS-5540	A	*	*	*	*	*	*	*	*	*	*
	C	*	*				*	*	*	*	*
	E					*	*	*			
	F	*					*				*
	G					*					
	H					*					*
	I	*	*			*	*	*	*	*	*

		01	02	03	04	05	06	11	12	13	14
HEDS-5545	A								*		*
	C								*		
	H						*				*
	I						*				
HEDS-5600	A						*		*	*	*
	C						*		*		*
	E						*				
	G						*			*	
	H						*		*		
	I	*						*			
HEDS-5605	A						*			*	
	C						*				
	E						*				
	F									*	
	G						*				
	H						*				*
HEDS-5640	A						*		*	*	
	E						*				
	F						*				
	H						*				
	I						*				
	S										*
HEDS-5645	A						*		*	*	
	C						*			*	
	E						*			*	
	G						*			*	
	H						*		*	*	*
	I						*			*	

For product information and a complete list of distributors, please go to our web site: [www.avagotech.com](http://www.avagotech.com)

Avago, Avago Technologies, and the A logo are trademarks of Avago Technologies in the United States and other countries. Data subject to change. Copyright © 2005-2014 Avago Technologies. All rights reserved. AV02-1046EN - November 20, 2014



## Application Brief M-101

### Introduction

This guide answers the most often-asked questions about encoders in general and Avago Technologies encoders in particular. It is organized into the following sections:

- General Encoding
- Output Waveforms
- Resolution
- Mounting
- Materials
- Reliability
- Electrical
- Miscellaneous

### General Encoding

#### Question 1. What is an encoder?

**Answer.** An encoder is a sensor of mechanical motion. It translates motion (such as position, velocity, and acceleration) into electrical signals.

#### Question 2. What kinds of encoders are available?

**Answer.** The three basic types of encoders are contact (also called resistive or potentiometers), magnetic, and optical. Contact encoders use either a wiper which picks off a voltage corresponding to its position, or has a brush or series of brushes which wipe along a codewheel with an alternating conductor/insulator pattern. The pattern of insulator and conductor corresponds to mechanical position. Magnetic encoders sense a magnetic field which changes according to mechanical position. Examples of magnetic encoders include synchros, resolvers, and Hall effect sensors. Optical encoders have a light source which shines through or reflects off a codewheel or codestrip to a photodetector. The photodetector sees a pattern of light and dark which corresponds to the mechanical position.

Encoders generate either analog or digital output signals. An analog encoder may put out a voltage or a series of voltages corresponding to position, velocity, etc. A digital encoder puts out signals which represent a binary 1 or 0 (logic level high or low). The coding of the 1's and 0's determines the position.

#### Question 3. What is the difference between an absolute and an incremental encoder?

**Answer.** Absolute encoders have a unique value (voltage, binary count) for each mechanical position and thus the position is known "absolutely". At power up, the position of an absolute encoder is known. Incremental encoders have output signals which repeat over the range of motion and thus each mechanical position is not uniquely defined. The current position sensed is only incremental from the last position sensed. Thus at power up, the position of an incremental encoder is not known since the output signals are not unique to any singular position. Count and direction information can be obtained from both absolute and incremental encoders.

#### Question 4. What is a channel?

**Answer.** A channel is an electrical output signal from an encoder. Typical high performance incremental encoders have either two or three channels.

#### Question 5. What is quadrature?

**Answer.** All Avago encoders have channels A and B which output identical repeating square waves as motion occurs. Channel A is offset from channel B by half of a high pulse of the square wave on either channel. Quadrature is the offset relationship between channel A and channel B.

#### Question 6. What is meant by 4X decoding?

**Answer.** The rising edge to rising edge (called the Cycle) on either channel A or B signifies that one window and bar pair of the codewheel has rotated by the photodetector array. Because A and B are in quadrature, four unique logic states are defined for each window and bar pair that mechanically passes. When these four unique logic states are decoded, the resolution obtained is four times (4X) the resolution of the codewheel. Thus a codewheel with 500 window and bar pairs can be decoded into 2000 quadrature states. See Figure 1 for more details.

**Question 7. What is an index pulse?**

**Answer.** An index pulse occurs on a third channel called channel I. A pulse occurs on this channel once for each full revolution of the codewheel. Essentially, this pulse marks a singular position of the codewheel. This is an absolute reference added to an incremental encoder.

**Question 8. Of Cycle, Pulse Width, and State Width, which is the most consistent?**

**Answer.** Cycle is the most consistent. If you are trying to measure velocity by timing between edges, use the rising to rising (or falling to falling) on either channel A or B. Pulse width and state width are not as consistent.

**Question 9. What other terms are used within the industry to describe output waveforms?**

**Answer.** Other terms in the industry include:  
*Phase:* rising edge on A to rising edge on B. (This is equivalent to Avago's State 1 width. Avago defines phase as the center of the high state on A to the center of the high state on B.)  
*Flutter:* variation from cycle to adjacent cycle.  
*Duty Jitter, Waterfall:* variation from pulse width to adjacent pulse width.  
*Symmetry:* ratio between pulse high and pulse low (nominally unity).  
*Edge to Edge Variation, Edge Separation, Phase Error:* equivalent to State Width Error.  
*Phase Jitter:* variation from rising edge on A to rising edge on B.

**Question 10. Do Avago encoders provide analog outputs (sinusoidal or quasi-sinusoidal signals)?**

**Answer.** No. Avago encoders provide only digital incremental output waveforms.

**Resolution**

**Question 11. How does Avago define resolution?**

**Answer.** Avago typically talks in terms of line density, which is the number of window and bar pairs per unit length. Line density is expressed either as lines per inch (LPin) or lines per mm (LPmm). For a rotary encoder, the line density is given by:

$$LPin (LPmm) = \frac{\text{Counts per Revolution}}{(2 \pi) (Rop)}$$

This gives the number of window and bar pairs per unit arc length at a given optical radius (Rop). For linear encoder modules, the resolution is the number of window and bar pairs per unit of linear length.

Alternative to line density is the counts per revolution (CPR) with a specified optical radius (for rotary encoders).

**Question 12. What are the minimum and maximum resolutions available with Avago encoder modules?**

**Answer.** Avago can make encoder modules with resolutions from 30 LPin to 360 LPin (1.18 LPmm to 14.17 LPmm).

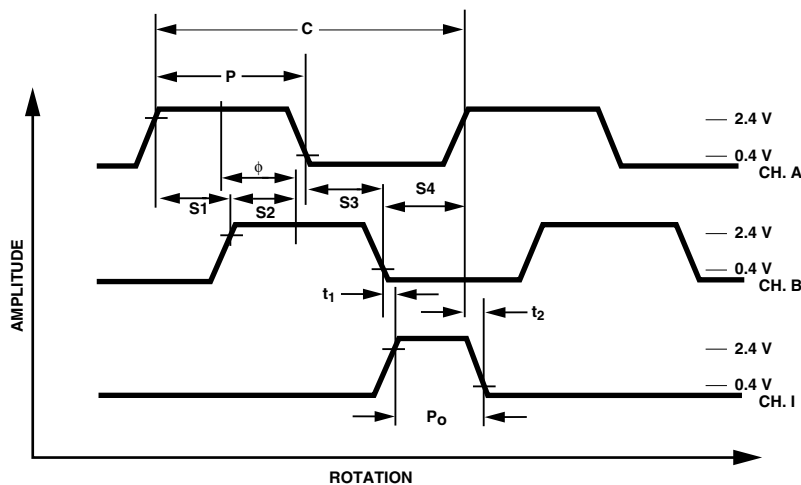

C = CYCLE (1 WINDOW AND BAR PAIR, 360°e)  
 S1 . . . S4 = LOGIC STATE WIDTH (4 STATES PER WINDOW AND BAR PAIR, EACH STATE IS 90°e)  
 P = PULSE WIDTH (RISING TO FALLING ON CH. A OR B, 180°e)  
 CH. I = INDEX CHANNEL (ONE PULSE PER FULL CODEWHEEL REVOLUTION)

**Figure 1. Output Waveforms.**

**Question 13. How can I get a rotary encoder resolution that is not one of the standard resolutions?**

**Answer.** Custom resolutions can be obtained by one of two ways. One way is to use a standard encoder module and design a custom codewheel. The line density of the module and the codewheel must match, but the optical radius can be varied to make a larger or smaller diameter codewheel which has a custom number of window and bar pairs.

**Example:** An application requires a 220 CPR encoder, which is between the HEDS-9100 standard resolutions of 200 CPR and 256 CPR.

**Steps:**

- a) Use HEDS-9100 #E00 (200 CPR at 11.00 mm  $R_{op}$ ,  $LP_{mm} = 2.89$  lines/mm).
- b) Match the  $LP_{mm}$  of the module with the  $LP_{mm}$  of the new codewheel and solve for a new optical radius:

$$LP_{mm} = \frac{CPR}{(2\pi)(R_{op})} \rightarrow R_{op} = \frac{CPR}{(2\pi)(LP_{mm})}$$

$$R_{op} = \frac{220 \text{ CPR}}{(2\pi)(2.89 \text{ lines/mm})} = 12.1 \text{ mm}$$

Thus the custom codewheel will be slightly larger than the standard codewheel to accommodate 20 extra window and bar pairs ( $R_{op} = 12.1$  mm vs.  $R_{op} = 11.00$  mm) but have the same line density. The modules are robust enough to handle the difference in optical radius.

The other way to get a custom resolution is to have Avago make a custom photodetector IC with the desired custom resolution. A custom codewheel is still required to work with the custom IC. Contact your local Avago sales representative for more information.

**Question 14. Will any codewheel work with any encoder module?**

**Answer.** No. The line densities of the module and codewheel must match. Thus a 200 LPin module will not work with a 120 LPin module.

**Question 15. How closely does the line density of the codewheel or codestrip have to match the line density of the module?**

**Answer.** For modules with less than 200 LPI resolution, a general rule of thumb is that the line densities must match within 5 lines/inch for the module to function (0.2 lines/mm). For higher resolution, above 200 LPI up to 360 LPI, the mismatch must be 3% or less from the encoder resolution. Encoding performance degrades with mismatch and thus Avago cannot guarantee encoding specifications when significant mismatch occurs.

**Question 16. Can I use an encoder module to detect the presence or absence of an object?**

**Answer.** No. The module is looking for a certain light/dark pattern. The passing of an opaque or transparent material past the photodetector array may or may not cause a transition on either channel. The result is not predictable.

---

## Mounting

**Question 17. How are the encoder module mounting tolerances referenced?**

**Answer.** For the HEDS-9000, 9100, and 9200 series encoder modules, the tolerances are referenced from the centers of the aligning recesses. For the HEDS-9700 series, the tolerances are referenced from the aligning post on the underside of the module.

**Question 18. Three-channel encoders and modules require use of an alignment tool or other aligning aid. Do you need an alignment tool for two channel encoders and modules?**

**Answer.** With the exception of the HEDS-9000/9100 Extended Resolution Series, alignment aids are not required. However, using alignment aids will result in better performance and are recommended. The Extended Resolution modules, which are the HEDS-9000 Options T and U and the HEDS-9100 Options B and J, do require the use of alignment aids. In some cases, alignment aids can also improve assembly times.

**Question 19. Can adhesives be used instead of screws?**

**Answer.** Yes. A common adhesive used is RTV, made by GE or Dow Corning (GE 162, Dow Corning 3145) among others.

**Question 20. What is meant by “artwork side of codewheel”?**

**Answer.** The artwork side only refers to codewheels that are made of glass or mylar (plastic). On these codewheels, the “art” or window/bar pattern appears only on one side. Generally, it is better to have the artwork side closer to the photodetector array to cast a cleaner, sharper shadow. With metal codewheels, both sides are equivalent since the window is an absence of material. The artwork side does not apply here.

**Question 21. How will the gap between the codewheel and the detector side of the encoder module affect the output?**

**Answer.** In general, Avago encoders are not that sensitive to the codewheel gap. This is because the lens collimates the LED light into a parallel beam and keeps the light/dark pattern fairly uniform. However, as the codewheel gets closer to the detector, the shadows cast by the codewheel get cleaner and sharper. This results in better light/dark contrast and subsequently somewhat better performance.

**Question 22. Does Avago provide mounting screws?**

**Answer.** No.

**Question 23. What is TIR?**

**Answer.** TIR stands for Total Indicated Runout and is the total movement that the codewheel window/bar pattern will have in a radial direction. Thus it is the total eccentricity of the codewheel. The factors which contribute to TIR are:

- Shaft eccentricity
- Shaft undersize relative to hub
- Off-center placement of hub relative to codewheel
- Shaft radial play due to bearing tolerance and uneven loading

TIR contributes directly to the cycle error and position error of the encoder.

**Question 24. Can Avago bend the leads of the encoder modules?**

**Answer.** Yes. The standard part numbers are:

HEDS-9101, HEDS-9041, HEDS-9141, HEDS-9701, HEDS-9721, HEDS-9731, and HEDS-9781.

**Question 25. How do you remove an HEDS-5500 series encoder?**

**Answer.** The HEDS-5500 series encoders were not designed to be removed. However, it is possible to do so if done carefully. The procedure to remove one is essentially the assembly procedure in reverse. The steps are as follows:

- a) Turn the encoder cap from the two-dot position to the one-dot position.
- b) Insert hex wrench into the side hole by the one-dot mark.
- c.) Push down on the hex wrench, and rotate the shaft slowly until you feel the setscrew. Insert wrench into hole and loosen setscrew. (This may take more than one attempt.)
- d) *Carefully* unsnap the encoder housing from the encoder baseplate. Gently lift the encoder housing up off the shaft. If the housing is pulled off too quickly, the codewheel may be damaged.
- e) Remove baseplate screws.

**Question 26. In the HEDS-5500 series assembly procedure, Step 4 calls for using the screwdriver slot to turn the encoder cap from the one-dot position to the two-dot position. If the encoder has an optional through-hole with no screwdriver slot, how do you turn from the one-dot to the two-dot position?**

**Answer.** Insert the hex wrench into one of the two side slots on the top of the encoder housing and rotate clockwise from the one-dot to the two-dot position.

---

**Materials**

**Question 27. What is the material of the encoder module housing?**

**Answer.** For the HEDS-90xx/91xx/92xx, the material is Ryton R-4, a type of polyester with glass filling. For the HEDS-9700 series, the housing material is a type of polyester with glass filling named Valox.

**Question 28. What is the material of the HEDS-5500, HEDS-6500 and HEDR-542x series housing?**

**Answer.** All the housings of the above mentioned encoder series are made of Valox, polyester filled with glass.

**Question 29. What is the lens made of?**

**Answer.** The lens is polycarbonate. HEDR-8xxx lens is a type of epoxy based mold compound.



**Question 30. What are the codewheels made of?**

**Answer.** Codewheels are made either of nickel, nickel-plated copper, or stainless steel and glass. The hubs are made of aluminum. The codewheel setscrew is made of black anodized high-carbon steel.

---

**Reliability**

**Question 31. Is there a reliability data sheet for Avago encoders?**

**Answer.** Yes, reliability data sheets are available for the HEDS-9000, HEDS-9100, HEDS-9200, HEDS-5500, HEDS-6500, HEDR-542x and HEDR-8000 series.

**Question 32. Will Avago encoders work in a vacuum?**

**Answer.** Avago encoders are not characterized nor were they intended to work in a vacuum. Customers have tried with varying amounts of success.

**Question 33. Will Avago encoders work in a radioactive environment?**

**Answer.** Again, they were not characterized or intended for such conditions. Customers have tried this also, again with different amounts of success.

**Question 34. Will Avago encoders work in a fluid?**

**Answer.** No. Fluids ruin the optics, potentially cause electrical problems, and, depending on the fluid, may destroy the materials of the encoder.

**Question 35. How well do Avago encoders work in a dusty environment?**

**Answer.** Avago encoders are fairly robust to dusty environments. The encoders look at multiple sets of window and bar pairs. Thus a speck of dust at any one window will be averaged out by the other sets of windows and bars. Because of this averaging effect, a number of windows can be covered completely and the module will still not lose a count.

**Question 36. What solvents can be used to clean in the vicinity of the encoder modules?**

**Answer.** Avago has found that almost all solvents (besides water) will attack some part of the encoder module. This includes alcohols and freon-based cleaners. Avago has not qualified any solvent to be compatible with the encoder modules.

---

**Electrical**

**Question 37. What kind of output drives do Avago encoders have?**

**Answer.** Avago encoders have a current source output of 125  $\mu$ A typical, 40  $\mu$ A minimum in the high state. The outputs can sink up to 3.2 mA under Recommended Operating Conditions (3.86 mA for the three-channel HEDS-9040/9140, HEDS-5540/5640).

**Question 38. I am trying to drive a fairly long length of cable. What kind of additional circuitry should I consider?**

**Answer.** For cable in the 6 to 10 foot range, pull-up resistors to +5 V on each output channel may suffice (3.3 k $\Omega$  for two channel, 2.7 k $\Omega$  for three channel). For longer lengths of cable, either a buffer or a line driver may be necessary.

**Question 39. I am having some problems with noise affecting my encoder signals. What should I do?**

**Answer.** There are several ways to improve noise immunity. Be careful to separate motor driver wires from encoder wires, and be sure to separate encoder channels from each other (i.e., do not twist CH A with CH B or CH I). Shielded twisted pair cable is recommended for encoder lines. Also, be sure to separate the ground lines of the motor/amplifier and the encoder since high current switching in the motor can cause noise in the encoder output lines.

Pull-up resistors help somewhat with noise rejection. Additional circuitry, such as line drivers/receivers and optocouplers, is much more effective in rejecting noise. In really noisy environments, additional circuitry may be the only way to totally eliminate a noise problem.

**Question 40. Does Avago provide line driver outputs?**

**Answer.** Yes. Avago has made available the HEDL-55xx/56xx encoders, which are HEDS-55xx/56xx encoders with a line driver board. This board uses an industry standard 26LS31 line driver IC. The line driver outputs are RS-422 compatible and provide complementary outputs on a 19-inch twisted pair ribbon cable. Both two and three channel encoders are available with the line driver option.

**Question 41. What is meant by “push-pull” circuitry?**

**Answer.** In determining the output for Channel A, the encoder photodetector is looking for signals for A and its complement A'. These signals are sent to a comparator such that when A receives more light than A', Ch. A is high. If A' receives more light than A, Ch. A is low. This arrangement is called “push-pull” circuitry.

The advantage is that the Ch. A output is insensitive to variation in the LED light level since A and A' are affected equally by the light source. Channels B and I are configured similarly.

**Question 42. Typically, how much current do the LED and photo-detector IC draw?**

**Answer.** In the two channel modules and encoders, the LED typically draws about 15 mA and the IC draws about 2 mA. In the three channel modules and encoders, the LED draws about 45 mA and the IC draws about 10 to 12 mA.

---

**Miscellaneous**

**Question 43. Does Avago provide codestrips?**

**Answer.** Avago does not sell codestrips, but a list of codestrip and codewheel vendors can be provided. Please contact Avago for further information.

**Question 44. How thick is an Avago codewheel?**

**Answer.** Codewheel thickness ranges from 0.054 mm (0.002 in.) to 0.55 mm (0.022 in.).

**Question 45. On the HEDS-9000/9100/9200 encoder modules, there are two metal straps on either side of the five pinouts. What are they for? Can they be cut or removed?**

**Answer.** These are the Ground and V<sub>CC</sub> lines which carry current to the LED light source. The pinouts, where the user connects Ground and V<sub>CC</sub>, are on the detector side of the module. The “straps” carry current to the emitter side of the module. If these lines are cut, the LED will not light up and the module will obviously not function.

**Question 46. Where is the index located on a 3-channel housed encoder?**

**Answer.** The index location is indicated on the HEDS-5500 data sheet. The index is located in the 6:00 position when the hex wrench is seated in the encoder set screw. The location is accurate within ±5 degrees.

**Question 47. What torque should be applied to a codewheel setscrew?**

**Answer.** To ensure proper attachment of the codewheel to a shaft, proper torque must be applied. Torque applied once the setscrew has made contact with the shaft should be in the range 7 to 18 oz-in. This range is appropriate for most shafts. For harder shafts, applied torque may need to be in the high end of the stated range.

Exceeding the 18 oz-in maximum torque may strip the threads inside the hub. Applying less torque than 7 oz-in may result in movement of the setscrew in the application. In both cases the hub will slip and the encoder will not function.

**Question 48. What is the necessary supply current for the HCTL-2000, HCTL-2016, and HCTL-2020?**

**Answer.** The current used by the HCTL-20xx is 1 μA typical, 5 μA maximum. This value is the quiescent supply current, I<sub>dd</sub>, on the data sheet. This data does not include current sourced in the output low condition, which is shown as a maximum of 4.8 mA on each of the 11 outputs (for the HCTL-2020). Therefore, the maximum necessary supply current can be calculated as:

$$5 \mu\text{A} + 11 \cdot 4.8 \text{ mA} = 52.8 \text{ mA}$$

However, if the interfacing electronics are implemented in CMOS with low input currents, one can see how the total current consumption can be reduced.

For example, with input current of 1 uA, current consumed drops:

$$5 \mu\text{A} + 11 \cdot 1 \mu\text{A} = 16 \mu\text{A}$$

This data is only for the quiescent state and does not include current consumed when switching states.

In most applications this is not a problem because the time spent switching is a small percentage of the total time.

**Question 49. What is the mating connector for the HEDR-54xx?**

**Answer.** The mating connector for the HEDR-54xx is made by Molex. (Part Number 51021-0500)

**Question 50. How far can an Encoder Line Driver transmit its signal?**

**Answer.** The line driver uses a 26LS31 driver to produce a complementary output. This chip produces signals in accordance with the RS-422-C standard. Transmission lengths vary based on frequency of the signal. The chip should be able to drive a signal across 4000 ft. of cable if the frequency of the signal is less than 100 kHz. If the frequency is around 10 MHz, the cable length decreases to 10 ft.

**Question 51. All About Connectors for the HEDS-5500/5600/5700.**

**Answer.** There are three connectors for the HEDx-55xx/56xx/57xx series of encoders. These connectors lock onto the back of any non-line driver or non-cabled version of these encoders. The part numbers are:

HEDS-8902: Four wire leads for 2-channel parts

HEDS-8903: Five wire leads for 3-channel parts

HEDS-8904: Empty connector for customer to build own cable

The HEDS-8904 is the locking part only. The customer needs to supply the housing for the pins

(Berg Part Number 65039-032) and the contacts for each electrical connection (Berg Part Number 48045-000).

The HEDS-8904 housing fits around the 65039 housing and adds the ability to lock the connector into the back of the encoder.

Assembly instructions for HEDS-8904:

1. Crimp terminals onto wires.
2. Insert terminals into 65039 housing.
3. Insert 65039 housing into HEDS-8904 Housing.

**Question 52. What is the torque specification for the HRPG-AS16, HRPG-AS32, and HRPG-ASCA?**

**Answer.** The torque specification for the smooth versions of the HRPG series is 10 gmf-cm to 40 gmf-cm. This is not the specification for the detented versions.

**Question 53. What is the effect of reflow soldering on Avago Encoders?**

**Answer.** The HEDR-8000 and HEDR-8100 series encoders are designed for IR reflow soldering.

The HEDS-90xx, HEDS-91xx, HEDS-92xx, and HEDS-97xx encoders are not compatible with IR soldering. These encoders have a PVC lens that will melt at the temperatures involved with IR Reflow soldering. The lens will deform and damage the optics of the device. Failure may not be imminent, but performance over life will be greatly reduced as will robustness to dirt and mounting errors.

For product information and a complete list of distributors, please go to our web site: [www.avagotech.com](http://www.avagotech.com)

Avago, Avago Technologies, and the A logo are trademarks of Avago Technologies in the United States and other countries. Data subject to change. Copyright © 2005-2010 Avago Technologies. All rights reserved. 5988-5062EN - October 19, 2010

**AVAGO**  
TECHNOLOGIES



Компания «ЭлектроПласт» предлагает заключение долгосрочных отношений при поставках импортных электронных компонентов на взаимовыгодных условиях!

Наши преимущества:

- Оперативные поставки широкого спектра электронных компонентов отечественного и импортного производства напрямую от производителей и с крупнейших мировых складов;
- Поставка более 17-ти миллионов наименований электронных компонентов;
- Поставка сложных, дефицитных, либо снятых с производства позиций;
- Оперативные сроки поставки под заказ (от 5 рабочих дней);
- Экспресс доставка в любую точку России;
- Техническая поддержка проекта, помощь в подборе аналогов, поставка прототипов;
- Система менеджмента качества сертифицирована по Международному стандарту ISO 9001;
- Лицензия ФСБ на осуществление работ с использованием сведений, составляющих государственную тайну;
- Поставка специализированных компонентов (Xilinx, Altera, Analog Devices, Intersil, Interpoint, Microsemi, Aeroflex, Peregrine, Syfer, Eurofarad, Texas Instrument, Miteq, Cobham, E2V, MA-COM, Hittite, Mini-Circuits, General Dynamics и др.);

Помимо этого, одним из направлений компании «ЭлектроПласт» является направление «Источники питания». Мы предлагаем Вам помощь Конструкторского отдела:

- Подбор оптимального решения, техническое обоснование при выборе компонента;
- Подбор аналогов;
- Консультации по применению компонента;
- Поставка образцов и прототипов;
- Техническая поддержка проекта;
- Защита от снятия компонента с производства.



#### Как с нами связаться

**Телефон:** 8 (812) 309 58 32 (многоканальный)

**Факс:** 8 (812) 320-02-42

**Электронная почта:** [org@eplast1.ru](mailto:org@eplast1.ru)

**Адрес:** 198099, г. Санкт-Петербург, ул. Калинина, дом 2, корпус 4, литера А.