

FEATURES

- 100% Tested Low Voltage Noise:
 $2.7\text{nV}/\sqrt{\text{Hz}}$ Typ
 $4.2\text{nV}/\sqrt{\text{Hz}}$ Max
- Slew Rate: $4.5\text{V}/\mu\text{s}$ Typ
- Gain-Bandwidth Product: 12.5MHz Typ
- Offset Voltage,
 Prime Grade: $70\mu\text{V}$ Max
 Low Grade: $100\mu\text{V}$ Max
- High Voltage Gain: 5 Million Min
- Supply Current Per Amplifier: 2.75mA Max
- Common Mode Rejection: 112dB Min
- Power Supply Rejection: 116dB Min
- Available in 8-Pin SO Package

APPLICATIONS

- Two and Three Op Amp Instrumentation Amplifiers
- Low Noise Signal Processing
- Active Filters
- Microvolt Accuracy Threshold Detection
- Strain Gauge Amplifiers
- Direct Coupled Audio Gain Stages
- Tape Head Preamplifiers
- Infrared Detectors

DESCRIPTION

The **LT[®]1124** dual and **LT1125** quad are high performance op amps that offer higher gain, slew rate and bandwidth than the industry standard OP-27 and competing OP-270/OP-470 op amps. In addition, the LT1124/LT1125 have lower I_B and I_{OS} than the OP-27; lower V_{OS} and noise than the OP-270/OP-470.

In the design, processing and testing of the device, particular attention has been paid to the optimization of the entire distribution of several key parameters. Slew rate, gain bandwidth and 1kHz noise are 100% tested for each individual amplifier. Consequently, the specifications of even the lowest cost grades (the LT1124C and the LT1125C) have been spectacularly improved compared to equivalent grades of competing amplifiers.

Power consumption of the LT1124 is one-half of two OP-27s. Low power and high performance in an 8-pin SO package make the LT1124 a first choice for surface mounted systems and where board space is restricted.

For a decompensated version of these devices, with three times higher slew rate and bandwidth, please see the LT1126/LT1127 data sheet.

LT, **LT**, **LTC**, **LTM**, Linear Technology and the Linear logo are registered trademarks of Linear Technology Corporation. All other trademarks are the property of their respective owners. Protected by U.S. Patents including 4775884, 4837496.

TYPICAL APPLICATION

Instrumentation Amplifier with Shield Driver



1124/25 TA01

Input Offset Voltage Distribution
 (All Packages, LT1124 and LT1125)

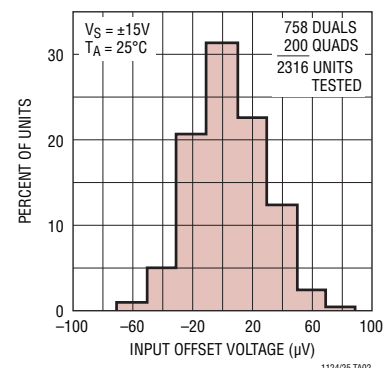

1124/25 TA02

LT1124/LT1125

ABSOLUTE MAXIMUM RATINGS

(Note 1)

Supply Voltage±22V
 Input VoltagesEqual to Supply Voltage
 Output Short-Circuit Duration Indefinite
 Differential Input Current (Note 6)±25mA
 Lead Temperature (Soldering, 10 sec)..... 300°C
 Storage Temperature Range -65°C to 150°C

Operating Temperature Range

LT1124AC/LT1124C

LT1125AC/LT1125C (Note 10) -40°C to 85°C

LT1124AI/LT1124I -40°C to 85°C

LT1124AMP/LT1125MP -55°C to 125°C

LT1124AM/LT1124M

LT1125AM/LT1125M

OBSOLETE..... -55°C to 125°C

PIN CONFIGURATION

| | | |
|---|--|--|
| <p>TOP VIEW</p> <p>S8 PACKAGE 8-LEAD PLASTIC SO</p> <p>$T_{JMAX} = 140^{\circ}C, \theta_{JA} = 190^{\circ}C/W$</p> <p>NOTE: THIS PIN CONFIGURATION DIFFERS FROM THE 8-PIN PDIP CONFIGURATION. INSTEAD, IT FOLLOWS THE ROTATED LT1013DS8 SO PACKAGE PIN LOCATIONS</p> | <p>TOP VIEW</p> <p>S8 PACKAGE 8-LEAD PLASTIC SO</p> <p>$T_{JMAX} = 150^{\circ}C, \theta_{JA} = 190^{\circ}C/W$</p> <p>OBSOLETE PINOUT</p> | <p>TOP VIEW</p> <p>N8 PACKAGE 8-LEAD PDIP</p> <p>$T_{JMAX} = 140^{\circ}C, \theta_{JA} = 130^{\circ}C/W$</p> <p>J8 PACKAGE 8-LEAD CERAMIC DIP</p> <p>$T_{JMAX} = 160^{\circ}C, \theta_{JA} = 100^{\circ}C/W$</p> <p>OBSOLETE PACKAGE Consider the N8 for Alternate Source</p> |
| <p>TOP VIEW</p> <p>SW PACKAGE 16-LEAD PLASTIC SO WIDE</p> <p>$T_{JMAX} = 140^{\circ}C, \theta_{JA} = 130^{\circ}C/W$</p> | <p>TOP VIEW</p> <p>N PACKAGE 14-LEAD PDIP</p> <p>$T_{JMAX} = 140^{\circ}C, \theta_{JA} = 110^{\circ}C/W (N)$</p> <p>J PACKAGE 14-LEAD CERAMIC DIP</p> <p>$T_{JMAX} = 160^{\circ}C, \theta_{JA} = 80^{\circ}C/W$</p> <p>OBSOLETE PACKAGE Consider the N for Alternate Source</p> | |

11245ff

ORDER INFORMATION

| LEAD FREE FINISH | TAPE AND REEL | PART MARKING* | PACKAGE DESCRIPTION | SPECIFIED TEMPERATURE RANGE |
|-------------------------|---------------------|---------------|------------------------------------|-----------------------------|
| LT1124CS8#PBF | LT1124CS8#TRPBF | 1124 | 8-Lead Plastic SO, Rotated Pinout | 0°C to 70°C |
| LT1124AIS8#PBF | LT1124AIS8#TRPBF | 1124AI | 8-Lead Plastic SO, Rotated Pinout | -40°C to 85°C |
| LT1124IS8#PBF | LT1124IS8#TRPBF | 1124I | 8-Lead Plastic SO, Rotated Pinout | -40°C to 85°C |
| LT1124AMPS8#PBF | LT1124AMPS8#TRPBF | 124AMP | 8-Lead Plastic SO, Rotated Pinout | -55°C to 125°C |
| LT1124CS8-1#PBF | LT1124CS8-1#TRPBF | 11241 | 8-Lead Plastic SO, Standard Pinout | 0°C to 70°C |
| LT1124AIS8-1#PBF | LT1124AIS8-1#TRPBF | 11241 | 8-Lead Plastic SO, Standard Pinout | -40°C to 85°C |
| LT1124IS8-1#PBF | LT1124IS8-1#TRPBF | 11241 | 8-Lead Plastic SO, Standard Pinout | -40°C to 85°C |
| LT1124AMPS8-1#PBF | LT1124AMPS8-1#TRPBF | 11241 | 8-Lead Plastic SO, Standard Pinout | -55°C to 125°C |
| OBSOLETE PINOUT | | | | |
| LT1125CSW#PBF | LT1125CSW#TRPBF | LT1125CSW | 16-Lead Plastic SO Wide | 0°C to 70°C |
| LT1125MPSW | LT1125MPSW#TR | LT1125MPSW | 16-Lead Plastic SO Wide | -55°C to 125°C |
| LT1124ACN8#PBF | LT1124ACN8#TRPBF | LT1124ACN8 | 8-Lead PDIP | 0°C to 70°C |
| LT1124CN8#PBF | LT1124CN8#TRPBF | LT1124CN8 | 8-Lead PDIP | 0°C to 70°C |
| LT1125ACN#PBF | LT1125ACN#TRPBF | LT1125ACN | 14-Lead PDIP | 0°C to 70°C |
| LT1125CN#PBF | LT1125CN#TRPBF | LT1125CN | 14-Lead PDIP | 0°C to 70°C |
| LEAD BASED FINISH | TAPE AND REEL | PART MARKING* | PACKAGE DESCRIPTION | SPECIFIED TEMPERATURE RANGE |
| LT1124CS8 | LT1124CS8#TR | 1124 | 8-Lead Plastic SO, Rotated Pinout | 0°C to 70°C |
| LT1124AIS8 | LT1124AIS8#TR | 1124AI | 8-Lead Plastic SO, Rotated Pinout | -40°C to 85°C |
| LT1124IS8 | LT1124IS8#TR | 1124I | 8-Lead Plastic SO, Rotated Pinout | -40°C to 85°C |
| LT1125CSW | LT1125CSW#TR | LT1125CSW | 16-Lead Plastic SO Wide | 0°C to 70°C |
| LT1124ACN8 | LT1124ACN8#TR | LT1124ACN8 | 8-Lead PDIP | 0°C to 70°C |
| LT1124CN8 | LT1124CN8#TR | LT1124CN8 | 8-Lead PDIP | 0°C to 70°C |
| LT1125ACN | LT1125ACN#TR | LT1125ACN | 14-Lead PDIP | 0°C to 70°C |
| LT1125CN | LT1125CN#TR | LT1125CN | 14-Lead PDIP | 0°C to 70°C |
| LT1124CJ8 | LT1124CJ8#TR | LT1124CJ8 | 8-Lead CERAMIC DIP | 0°C to 70°C |
| LT1124AMJ8 | LT1124AMJ8#TR | LT1124AMJ8 | 8-Lead CERAMIC DIP | -55°C to 125°C |
| LT1124MJ8 | LT1124MJ8#TR | LT1124MJ8 | 8-Lead CERAMIC DIP | -55°C to 125°C |
| LT1125CJ | LT1125CJ#TR | LT1125CJ | 14-Lead CERAMIC DIP | 0°C to 70°C |
| LT1125AMJ | LT1125AMJ#TR | LT1125AMJ | 14-Lead CERAMIC DIP | -55°C to 125°C |
| LT1125MJ | LT1125MJ#TR | LT1125MJ | 14-Lead CERAMIC DIP | -55°C to 125°C |
| OBSOLETE PACKAGE | | | | |

Consult LTC Marketing for parts specified with wider operating temperature ranges. *The temperature grade is identified by a label on the shipping container.

For more information on lead free part marking, go to: <http://www.linear.com/leadfree/>

For more information on tape and reel specifications, go to: <http://www.linear.com/tapeandreeel/>

LT1124/LT1125

ELECTRICAL CHARACTERISTICS $T_A = 25^\circ\text{C}$, $V_S = \pm 15\text{V}$, unless otherwise noted.

| SYMBOL | PARAMETER | CONDITIONS (Note 2) | LT1124AC/AI/AM LT1125AC/AM | | | LT1124C/I/M LT1125C/M | | | UNITS |
|--|--|---|-------------------------------|------------|------------|--------------------------|------------|------------|--|
| | | | MIN | TYP | MAX | MIN | TYP | MAX | |
| V_{OS} | Input Offset Voltage | LT1124 LT1125 | | 20 25 | 70 90 | | 25 30 | 100 140 | μV μV |
| $\frac{\Delta V_{OS}}{\Delta \text{Time}}$ | Long-Term Input Offset Voltage Stability | | | 0.3 | | | 0.3 | | $\mu\text{V}/\text{Mo}$ |
| I_{OS} | Input Offset Current | LT1124 LT1125 | | 5 6 | 15 20 | | 6 7 | 20 30 | nA nA |
| I_B | Input Bias Current | | | ± 7 | ± 20 | | ± 8 | ± 30 | nA |
| e_n | Input Noise Voltage | 0.1Hz to 10Hz (Notes 8, 9) | | 70 | 200 | | 70 | | $\text{nV}_{\text{p-p}}$ |
| | Input Noise Voltage Density | $f_0 = 10\text{Hz}$ (Note 5) $f_0 = 1000\text{Hz}$ (Note 3) | | 3.0 2.7 | 5.5 4.2 | | 3.0 2.7 | 5.5 4.2 | $\text{nV}/\sqrt{\text{Hz}}$ $\text{nV}/\sqrt{\text{Hz}}$ |
| i_n | Input Noise Current Density | $f_0 = 10\text{Hz}$ $f_0 = 1000\text{Hz}$ | | 1.3 0.3 | | | 1.3 0.3 | | $\text{pA}/\sqrt{\text{Hz}}$ $\text{pA}/\sqrt{\text{Hz}}$ |
| V_{CM} | Input Voltage Range | | ± 12 | ± 12.8 | | ± 12 | ± 12.8 | | V |
| CMRR | Common Mode Rejection Ratio | $V_{CM} = \pm 12\text{V}$ | 112 | 126 | | 106 | 124 | | dB |
| PSRR | Power Supply Rejection Ratio | $V_S = \pm 4\text{V}$ to $\pm 18\text{V}$ | 116 | 126 | | 110 | 124 | | dB |
| A_{VOL} | Large-Signal Voltage Gain | $R_L \geq 10\text{k}$, $V_{OUT} = \pm 10\text{V}$ $R_L \geq 2\text{k}$, $V_{OUT} = \pm 10\text{V}$ | 5 2 | 17 4 | | 3.0 1.5 | 15 3 | | $\text{V}/\mu\text{V}$ $\text{V}/\mu\text{V}$ |
| V_{OUT} | Maximum Output Voltage Swing | $R_L \geq 2\text{k}$ | ± 13 | ± 13.8 | | ± 12.5 | ± 13.8 | | V |
| SR | Slew Rate | $R_L \geq 2\text{k}$ (Notes 3, 7) | 3 | 4.5 | | 2.7 | 4.5 | | $\text{V}/\mu\text{s}$ |
| GBW | Gain-Bandwidth Product | $f_0 = 100\text{kHz}$ (Note 3) | 9 | 12.5 | | 8 | 12.5 | | MHz |
| Z_O | Open-Loop Output Resistance | $V_{OUT} = 0$, $I_{OUT} = 0$ | | 75 | | | 75 | | Ω |
| I_S | Supply Current per Amplifier | | | 2.3 | 2.75 | | 2.3 | 2.75 | mA |
| | Channel Separation | $f \leq 10\text{Hz}$ (Note 9) $V_{OUT} = \pm 10\text{V}$, $R_L = 2\text{k}$ | 134 | 150 | | 130 | 150 | | dB |

The ● denotes the specifications which apply over the $-55^\circ\text{C} \leq T_A \leq 125^\circ\text{C}$ temperature range, $V_S = \pm 15\text{V}$, unless otherwise noted.

| SYMBOL | PARAMETER | CONDITIONS (Note 2) | LT1124AM LT1125AM | | | LT1124M LT1125M | | | UNITS |
|--|------------------------------------|---|----------------------|------------|------------|--------------------|------------|------------|--|
| | | | MIN | TYP | MAX | MIN | TYP | MAX | |
| V_{OS} | Input Offset Voltage | LT1124 LT1125 | ● ● | 50 55 | 170 190 | | 60 70 | 250 290 | μV μV |
| $\frac{\Delta V_{OS}}{\Delta \text{Temp}}$ | Average Input Offset Voltage Drift | (Note 5) | ● | 0.3 | 1.0 | | 0.4 | 1.5 | $\mu\text{V}/^\circ\text{C}$ |
| I_{OS} | Input Offset Current | LT1124 LT1125 | ● ● | 18 18 | 45 55 | | 20 20 | 60 70 | nA nA |
| I_B | Input Bias Current | | ● | ± 18 | ± 55 | | ± 20 | ± 70 | nA |
| V_{CM} | Input Voltage Range | | ● | ± 11.3 | ± 12 | | ± 11.3 | ± 12 | V |
| CMRR | Common Mode Rejection Ratio | $V_{CM} = \pm 11.3\text{V}$ | ● | 106 | 122 | | 100 | 120 | dB |
| PSRR | Power Supply Rejection Ratio | $V_S = \pm 4\text{V}$ to $\pm 18\text{V}$ | ● | 110 | 122 | | 104 | 120 | dB |
| A_{VOL} | Large-Signal Voltage Gain | $R_L \geq 10\text{k}$, $V_{OUT} = \pm 10\text{V}$ $R_L \geq 2\text{k}$, $V_{OUT} = \pm 10\text{V}$ | ● ● | 3 1 | 10 3 | | 2.0 0.7 | 10 2 | $\text{V}/\mu\text{V}$ $\text{V}/\mu\text{V}$ |
| V_{OUT} | Maximum Output Voltage Swing | $R_L \geq 2\text{k}$ | ● | ± 12.5 | ± 13.6 | | ± 12 | ± 13.6 | V |
| SR | Slew Rate | $R_L \geq 2\text{k}$ (Notes 3, 7) | ● | 2.3 | 3.8 | | 2 | 3.8 | $\text{V}/\mu\text{s}$ |
| I_S | Supply Current per Amplifier | | ● | 2.5 | 3.25 | | 2.5 | 3.25 | mA |

11245ff

ELECTRICAL CHARACTERISTICS The ● denotes the specifications which apply over the $0^{\circ}\text{C} \leq T_A \leq 70^{\circ}\text{C}$ temperature range, $V_S = \pm 15\text{V}$, unless otherwise noted.

| SYMBOL | PARAMETER | CONDITIONS (Note 2) | | LT1124AC LT1125AC | | | LT1124C LT1125C | | | UNITS |
|--|------------------------------------|---|--------|----------------------|------------|------------|--------------------|------------|--|-------|
| | | | | MIN | TYP | MAX | MIN | TYP | MAX | |
| V_{OS} | Input Offset Voltage | LT1124 LT1125 | ● ● | | 35 40 | 120 140 | 45 50 | 170 210 | μV μV | |
| $\frac{\Delta V_{OS}}{\Delta \text{Temp}}$ | Average Input Offset Voltage Drift | (Note 5) | ● | | 0.3 | 1 | 0.4 | 1.5 | $\mu\text{V}/^{\circ}\text{C}$ | |
| I_{OS} | Input Offset Current | LT1124 LT1125 | ● ● | | 6 7 | 25 35 | 7 8 | 35 45 | nA nA | |
| I_B | Input Bias Current | | ● | | ± 8 | ± 35 | ± 9 | ± 45 | nA | |
| V_{CM} | Input Voltage Range | | ● | ± 11.5 | ± 12.4 | | ± 11.5 | ± 12.4 | V | |
| CMRR | Common Mode Rejection Ratio | $V_{CM} = \pm 11.5\text{V}$ | ● | 109 | 125 | | 102 | 122 | dB | |
| PSRR | Power Supply Rejection Ratio | $V_S = \pm 4\text{V}$ to $\pm 18\text{V}$ | ● | 112 | 125 | | 107 | 122 | dB | |
| A_{VOL} | Large-Signal Voltage Gain | $R_L \geq 10\text{k}$, $V_{OUT} = \pm 10\text{V}$ $R_L \geq 2\text{k}$, $V_{OUT} = \pm 10\text{V}$ | ● ● | 4.0 1.5 | 15 3.5 | | 2.5 1.0 | 14 2.5 | $\text{V}/\mu\text{V}$ $\text{V}/\mu\text{V}$ | |
| V_{OUT} | Maximum Output Voltage Swing | $R_L \geq 2\text{k}$ | ● | ± 12.5 | ± 13.7 | | ± 12 | ± 13.7 | V | |
| SR | Slew Rate | $R_L \geq 2\text{k}$ (Notes 3, 7) | ● | 2.6 | 4 | | 2.4 | 4 | $\text{V}/\mu\text{s}$ | |
| I_S | Supply Current per Amplifier | | ● | | 2.4 | 3 | 2.4 | 3 | mA | |

The ● denotes the specifications which apply over the $-40^{\circ}\text{C} \leq T_A \leq 85^{\circ}\text{C}$ temperature range, $V_S = \pm 15\text{V}$, unless otherwise noted. (Note 10)

| SYMBOL | PARAMETER | CONDITIONS (Note 2) | | LT1124AC/AI LT1125AC | | | LT1124C/I LT1125C | | | UNITS |
|--|------------------------------------|---|--------|-------------------------|------------|------------|----------------------|------------|--|-------|
| | | | | MIN | TYP | MAX | MIN | TYP | MAX | |
| V_{OS} | Input Offset Voltage | LT1124 LT1125 | ● ● | | 40 45 | 140 160 | 50 55 | 200 240 | μV μV | |
| $\frac{\Delta V_{OS}}{\Delta \text{Temp}}$ | Average Input Offset Voltage Drift | (Note 5) | ● | | 0.3 | 1 | 0.4 | 1.5 | $\mu\text{V}/^{\circ}\text{C}$ | |
| I_{OS} | Input Offset Current | LT1124 LT1125 | ● ● | | 15 15 | 40 50 | 17 17 | 55 65 | nA nA | |
| I_B | Input Bias Current | | ● | | ± 15 | ± 50 | ± 17 | ± 65 | nA | |
| V_{CM} | Input Voltage Range | | ● | ± 11.4 | ± 12.2 | | ± 11.4 | ± 12.2 | V | |
| CMRR | Common Mode Rejection Ratio | $V_{CM} = \pm 11.4\text{V}$ | ● | 107 | 124 | | 101 | 121 | dB | |
| PSRR | Power Supply Rejection Ratio | $V_S = \pm 4\text{V}$ to $\pm 18\text{V}$ | ● | 111 | 124 | | 106 | 121 | dB | |
| A_{VOL} | Large-Signal Voltage Gain | $R_L \geq 10\text{k}$, $V_{OUT} = \pm 10\text{V}$ $R_L \geq 2\text{k}$, $V_{OUT} = \pm 10\text{V}$ | ● ● | 3.5 1.2 | 12 3.2 | | 2.2 0.8 | 12 2.3 | $\text{V}/\mu\text{V}$ $\text{V}/\mu\text{V}$ | |
| V_{OUT} | Maximum Output Voltage Swing | $R_L \geq 2\text{k}$ | ● | ± 12.5 | ± 13.6 | | ± 12 | ± 13.6 | V | |
| SR | Slew Rate | $R_L \geq 2\text{k}$ (Notes 3, 7) | ● | 2.4 | 3.9 | | 2.1 | 3.9 | $\text{V}/\mu\text{s}$ | |
| I_S | Supply Current per Amplifier | | ● | | 2.4 | 3.25 | 2.4 | 3.25 | mA | |

ELECTRICAL CHARACTERISTICS

Note 1: Stresses beyond those listed under Absolute Maximum Ratings may cause permanent damage to the device. Exposure to any Absolute Maximum Rating condition for extended periods may affect device reliability and lifetime.

Note 2: Typical parameters are defined as the 60% yield of parameter distributions of individual amplifiers; i.e., out of 100 LT1125s (or 100 LT1124s) typically 240 op amps (or 120) will be better than the indicated specification.

Note 3: This parameter is 100% tested for each individual amplifier.

Note 4: This parameter is sample tested only.

Note 5: This parameter is not 100% tested.

Note 6: The inputs are protected by back-to-back diodes. Current limiting resistors are not used in order to achieve low noise. If differential input

voltage exceeds $\pm 1.4V$, the input current should be limited to 25mA.

Note 7: Slew rate is measured in $A_V = -1$; input signal is $\pm 7.5V$, output measured at $\pm 2.5V$.

Note 8: 0.1Hz to 10Hz noise can be inferred from the 10Hz noise voltage density test. See the test circuit and frequency response curve for 0.1Hz to 10Hz tester in the Applications Information section of the LT1007 or LT1028 data sheets.

Note 9: This parameter is guaranteed but not tested.

Note 10: The LT1124C/LT1125C and LT1124AC/LT1125AC are guaranteed to meet specified performance from $0^\circ C$ to $70^\circ C$ and are designed, characterized and expected to meet these extended temperature limits, but are not tested at $-40^\circ C$ and $85^\circ C$. The LT1124AI and LT1124I are guaranteed to meet the extended temperature limits.

TYPICAL PERFORMANCE CHARACTERISTICS

0.1Hz to 10Hz Voltage Noise

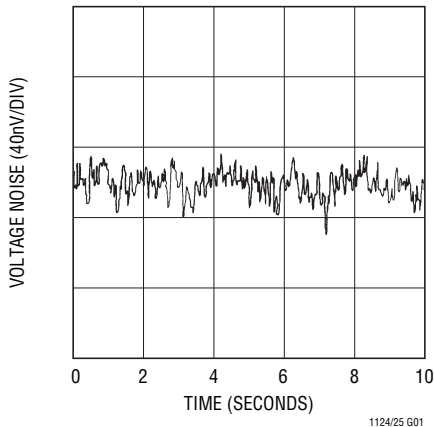

0.01Hz to 1Hz Voltage Noise

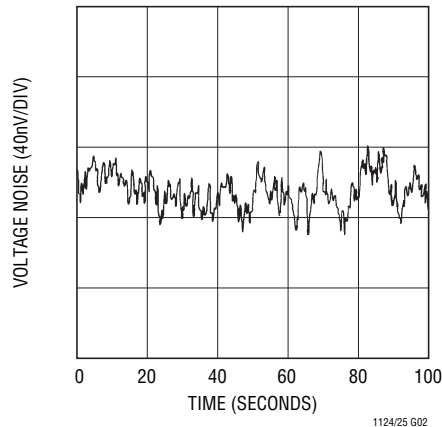

Voltage Noise vs Frequency

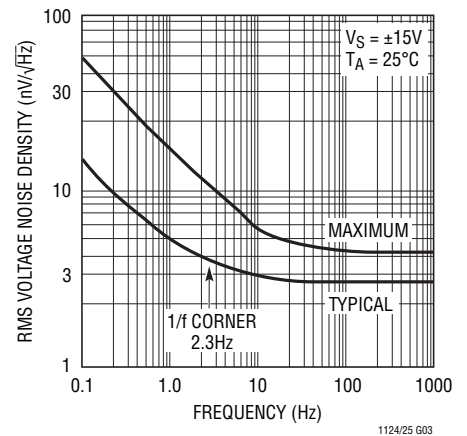

Current Noise vs Frequency

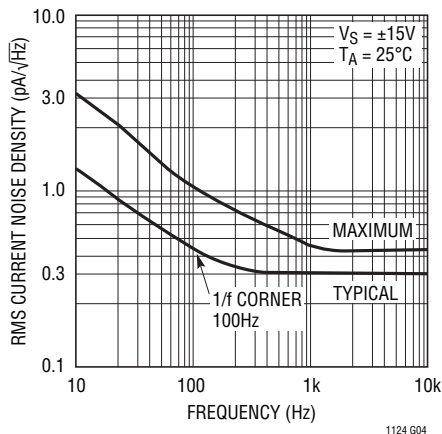

Input Bias or Offset Current vs Temperature

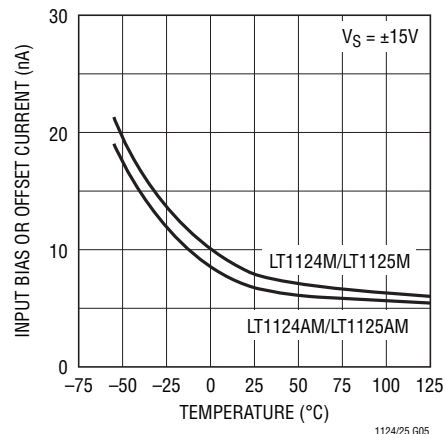

TYPICAL PERFORMANCE CHARACTERISTICS

Output Short-Circuit Current vs Time

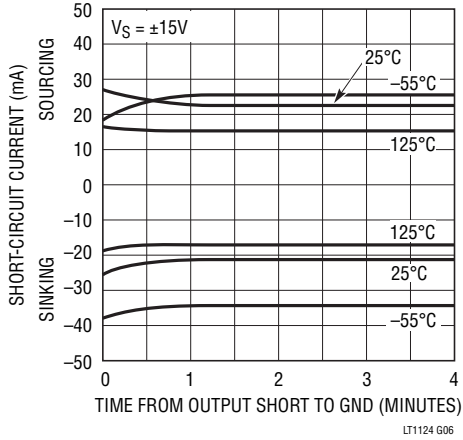

Input Bias Current Over the Common Mode Range



Common Mode Rejection Ratio vs Frequency

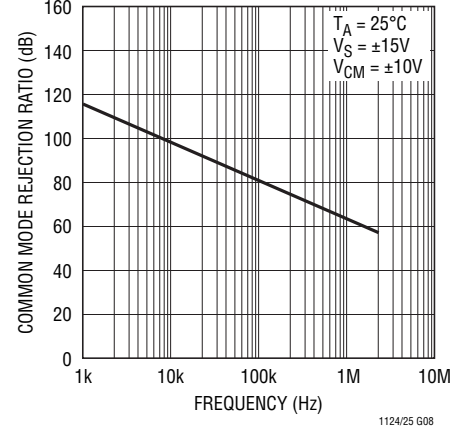

Power Supply Rejection Ratio vs Frequency

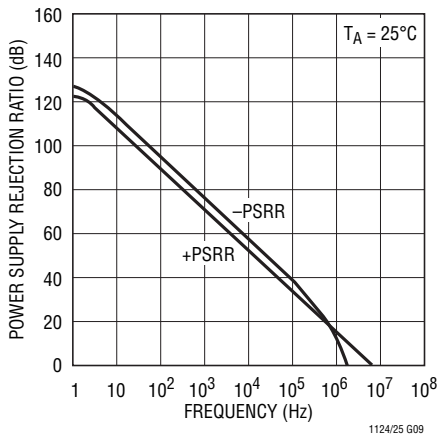

Voltage Gain vs Frequency

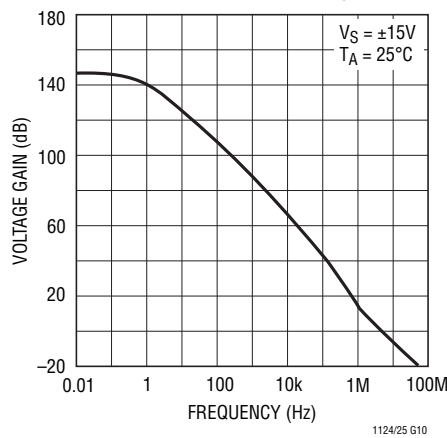

Voltage Gain vs Temperature

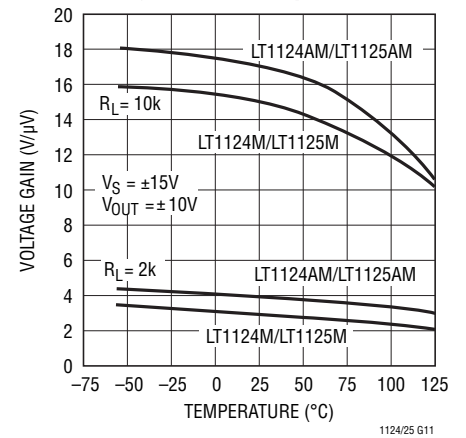

Gain, Phase Shift vs Frequency

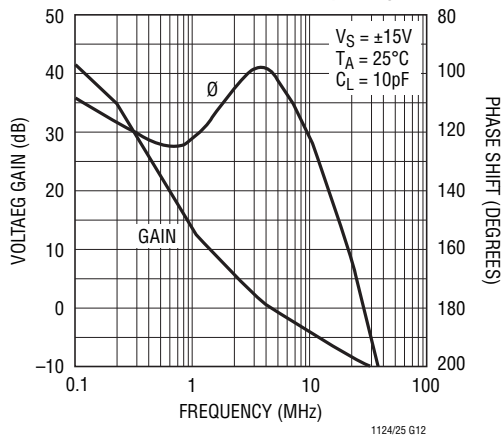

Input Offset Voltage Drift Distribution



TYPICAL PERFORMANCE CHARACTERISTICS

Offset Voltage Drift with Temperature of Representative Units

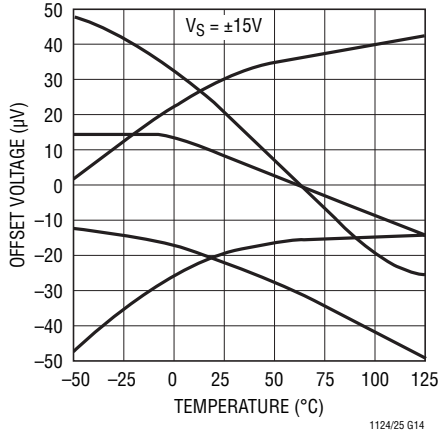

Supply Current vs Supply Voltage

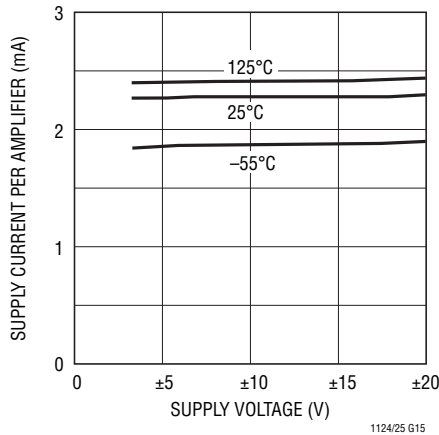

Small-Signal Transient Response

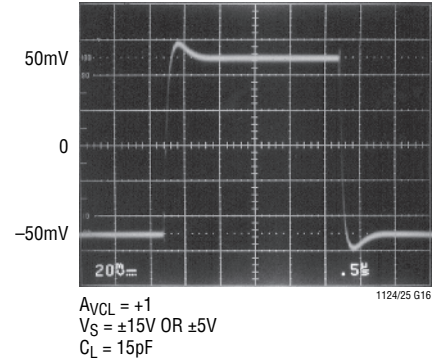

Large-Signal Transient Response

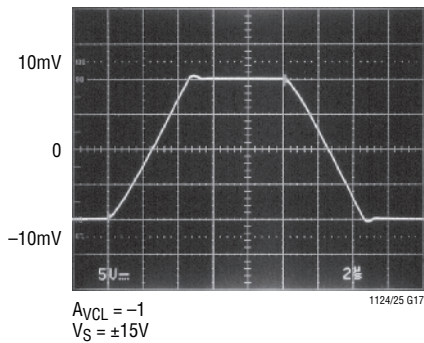

Output Voltage Swing vs Load Current

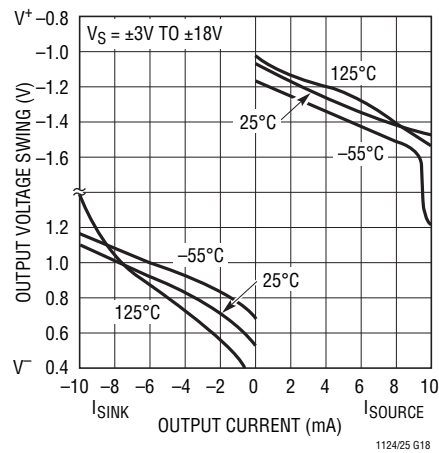

Common Mode Limit vs Temperature

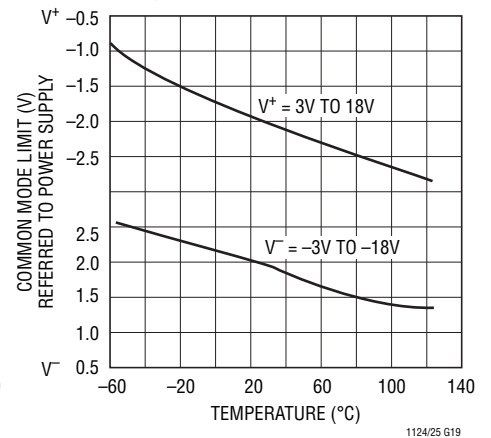

Channel Separation vs Frequency

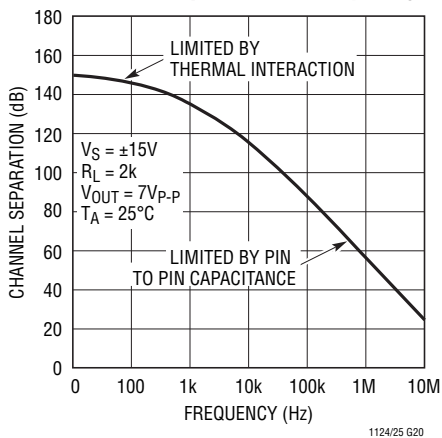

Warm-Up Drift

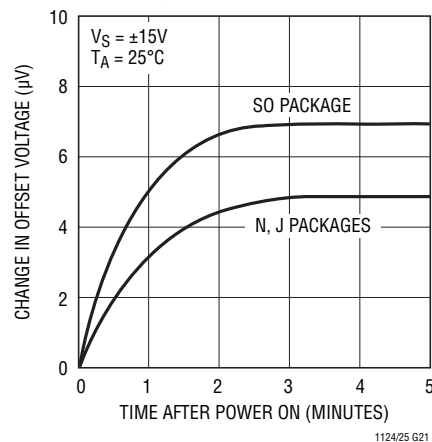

TYPICAL PERFORMANCE CHARACTERISTICS

Total Harmonic Distortion and Noise vs Frequency for Noninverting Gain

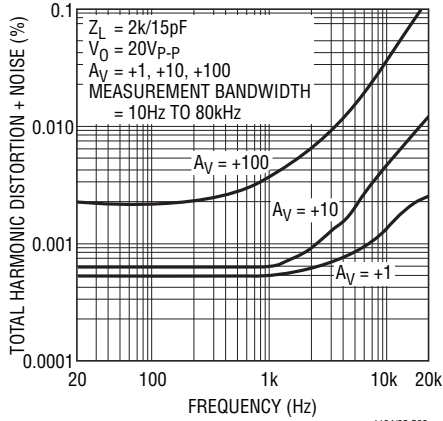

1124/25 G22

Total Harmonic Distortion and Noise vs Frequency for Inverting Gain

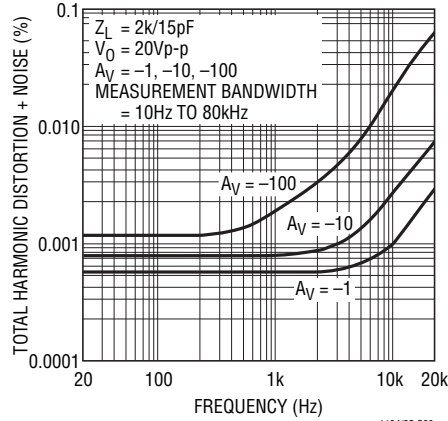

1124/25 G23

Total Harmonic Distortion and Noise vs Frequency for Competitive Devices

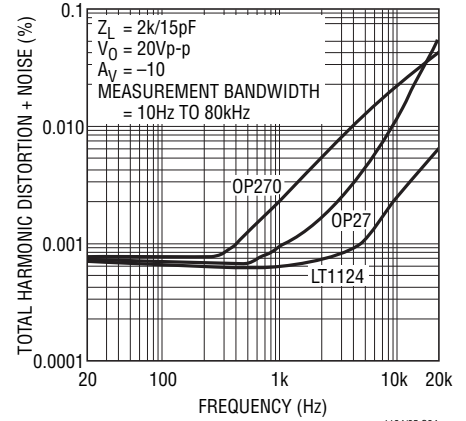

1124/25 G24

Total Harmonic Distortion and Noise vs Output Amplitude for Noninverting Gain

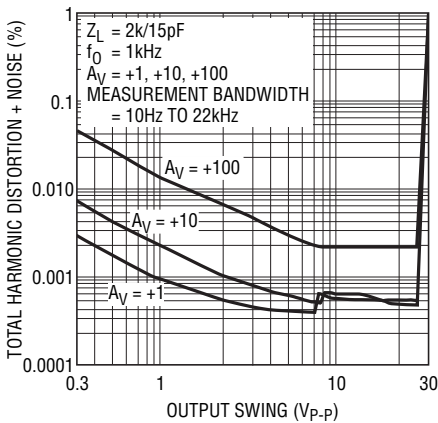

1124/25 G25

Total Harmonic Distortion and Noise vs Output Amplitude for Inverting Gain

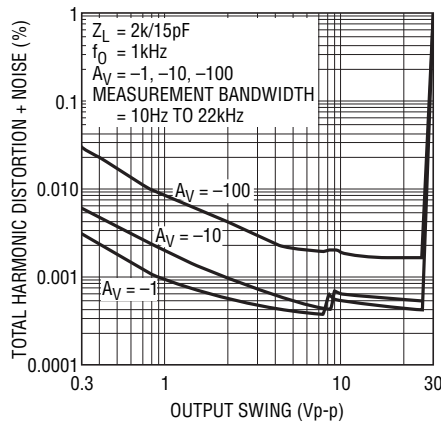

1124/25 G26

Intermodulation Distortion (CCIF Method)* vs Frequency LT1124 and OP270

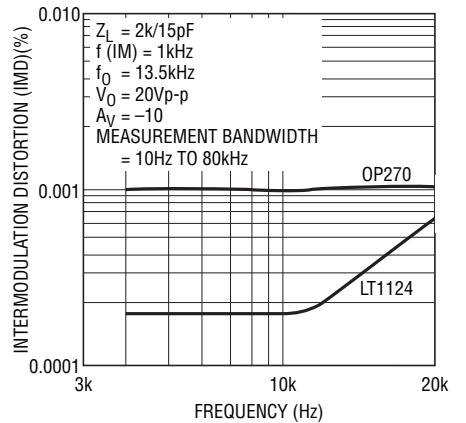

1124/25 G27

APPLICATIONS INFORMATION

The LT1124 may be inserted directly into OP-270 sockets. The LT1125 plugs into OP-470 sockets. Of course, all standard dual and quad bipolar op amps can also be replaced by these devices.

Matching Specifications

In many applications the performance of a system depends on the matching between two op amps, rather than the individual characteristics of the two devices. The three op amp instrumentation amplifier configuration shown in this data sheet is an example. Matching characteristics are not 100% tested on the LT1124/LT1125.

Some specifications are guaranteed by definition. For example, 70 μ V maximum offset voltage implies that mismatch cannot be more than 140 μ V. 112dB (= 2.5 μ V/V) CMRR means that worst-case CMRR match is 106dB

(5 μ V/V). However, Table 1 can be used to estimate the expected matching performance between the two sides of the LT1124, and between amplifiers A and D, and between amplifiers B and C of the LT1125.

Offset Voltage and Drift

Thermocouple effects, caused by temperature gradients across dissimilar metals at the contacts to the input terminals, can exceed the inherent drift of the amplifier unless proper care is exercised. Air currents should be minimized, package leads should be short, the two input leads should be close together and maintained at the same temperature.

The circuit shown in Figure 1 to measure offset voltage is also used as the burn-in configuration for the LT1124/LT1125, with the supply voltages increased to ± 16 V.

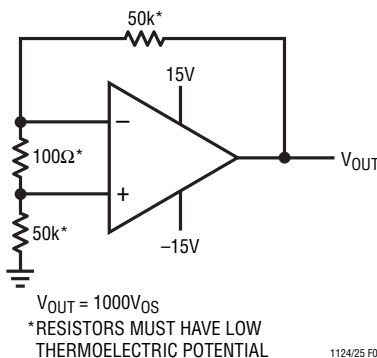

Figure 1. Test Circuit for Offset Voltage and Offset Voltage Drift with Temperature

Table 1. Expected Match

| PARAMETER | | LT1124AC/AM LT1125AC/AM | | LT1124C/M LT1125C/M | | UNITS |
|---------------------------------|--------|----------------------------|-----------|------------------------|-----------|-----------------------|
| | | 50% YIELD | 98% YIELD | 50% YIELD | 98% YIELD | |
| V_{OS} Match, ΔV_{OS} | LT1124 | 20 | 110 | 30 | 130 | μ V |
| | LT1125 | 30 | 150 | 50 | 180 | μ V |
| Temperature Coefficient Match | | 0.35 | 1.0 | 0.5 | 1.5 | μ V/ $^{\circ}$ C |
| Average Noninverting I_B | | 6 | 18 | 7 | 25 | nA |
| Match of Noninverting I_B | | 7 | 22 | 8 | 30 | nA |
| CMRR Match | | 126 | 115 | 123 | 112 | dB |
| PSRR Match | | 127 | 118 | 127 | 114 | dB |

APPLICATIONS INFORMATION

High Speed Operation

When the feedback around the op amp is resistive (R_F), a pole will be created with R_F , the source resistance and capacitance (R_S , C_S), and the amplifier input capacitance ($C_{IN} \approx 2\text{pF}$). In low closed loop gain configurations and with R_S and R_F in the kilohm range, this pole can create excess phase shift and even oscillation. A small capacitor (C_F) in parallel with R_F eliminates this problem (see Figure 2). With $R_S(C_S + C_{IN}) = R_F C_F$, the effect of the feedback pole is completely removed.

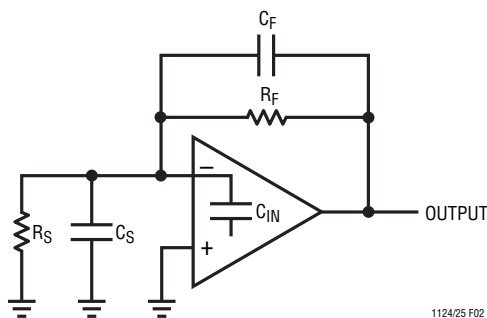

Figure 2. High Speed Operation

Unity Gain Buffer Applications

When $R_F \leq 100\Omega$ and the input is driven with a fast, large signal pulse ($>1\text{V}$), the output waveform will look as shown in Figure 3.

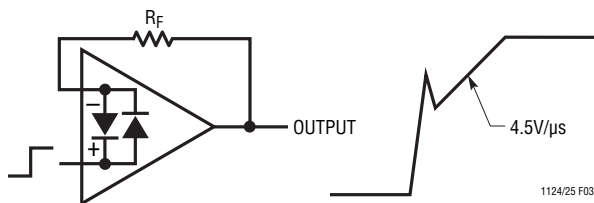

Figure 3. Unity-Gain Buffer Applications

During the fast feedthrough-like portion of the output, the input protection diodes effectively short the output to the input and a current, limited only by the output short circuit protection, will be drawn by the signal generator. With $R_F \geq 500\Omega$, the output is capable of handling the current requirements ($I_L \leq 20\text{mA}$ at 10V) and the amplifier stays in its active mode and a smooth transition will occur.

Noise Testing

Each individual amplifier is tested to $4.2\text{nV}/\sqrt{\text{Hz}}$ voltage noise; i.e., for the LT1124 two tests, for the LT1125 four tests are performed. Noise testing for competing multiple op amps, if done at all, may be sample tested or tested using the circuit shown in Figure 4.

$$e_{n \text{ OUT}} = \sqrt{(e_{nA})^2 + (e_{nB})^2 + (e_{nC})^2 + (e_{nD})^2}$$

If the LT1125 were tested this way, the noise limit would be $\sqrt{4 \cdot (4.2\text{nV}/\sqrt{\text{Hz}})^2} = 8.4\text{nV}/\sqrt{\text{Hz}}$. But is this an effective screen? What if three of the four amplifiers are at a typical $2.7\text{nV}/\sqrt{\text{Hz}}$, and the fourth one was contaminated and has $6.9\text{nV}/\sqrt{\text{Hz}}$ noise?

$$\text{RMS Sum} = \sqrt{(2.7)^2 + (2.7)^2 + (2.7)^2 + (6.9)^2} = 8.33\text{nV}/\sqrt{\text{Hz}}$$

This passes an $8.4\text{nV}/\sqrt{\text{Hz}}$ spec, yet one of the amplifiers is 64% over the LT1125 spec limit. Clearly, for proper noise measurement, the op amps have to be tested individually.

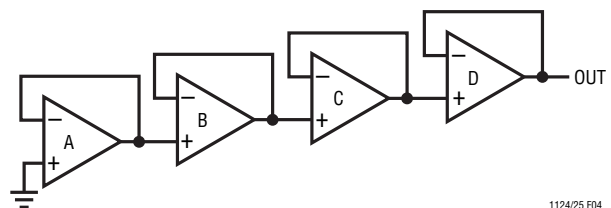

Figure 4. Competing Quad Op Amp Noise Test Method

LT1124/LT1125

PERFORMANCE COMPARISON

Table 2 summarizes the performance of the LT1124/LT1125 compared to the low cost grades of alternate approaches.

performance is degraded when compared to singles, for the LT1124/LT1125 this is not the case.

The comparison shows how the specs of the LT1124/LT1125 not only stand up to the industry standard OP-27, but in most cases are superior. Normally dual and quad

Table 2. Guaranteed Performance, $V_S = \pm 15V$, $T_A = 25^\circ C$, Low Cost Devices

| PARAMETER/UNITS | | LT1124CN8 LT1125CN | OP-27 GP | OP-270 GP | OP-470 GP | UNITS |
|------------------------------|--------|-----------------------|----------------------|---------------|----------------------|-----------------|
| Voltage Noise, 1kHz | | 4.2 100% Tested | 4.5 Sample Tested | – No Limit | 5.0 Sample Tested | nV/ \sqrt{Hz} |
| Slew Rate | | 2.7 100% Tested | 1.7 Not Tested | 1.7 | 1.4 | V/ μs |
| Gain-Bandwidth Product | | 8.0 100% Tested | 5.0 Not Tested | – No Limit | – No Limit | MHz |
| Offset Voltage | LT1124 | 100 | 100 | 250 | – | μV |
| | LT1125 | 140 | – | – | 1000 | μV |
| Offset Current | LT1124 | 20 | 75 | 20 | – | nA |
| | LT1125 | 30 | – | – | 30 | nA |
| Bias Current | | 30 | 80 | 60 | 60 | nA |
| Supply Current/Amp | | 2.75 | 5.67 | 3.25 | 2.75 | mA |
| Voltage Gain, $R_L = 2k$ | | 1.5 | 0.7 | 0.35 | 0.4 | V/ μV |
| Common Mode Rejection Ratio | | 106 | 100 | 90 | 100 | dB |
| Power Supply Rejection Ratio | | 110 | 94 | 104 | 105 | dB |
| SO-8 Package | | Yes – LT1124 | Yes | No | – | |

TYPICAL APPLICATIONS

Gain 1000 Amplifier with 0.01% Accuracy, DC to 1Hz



THE HIGH GAIN AND WIDE BANDWIDTH OF THE LT1124/LT1125, IS USEFUL IN LOW FREQUENCY HIGH CLOSED-LOOP GAIN AMPLIFIER APPLICATIONS. A TYPICAL PRECISION OP AMP MAY HAVE AN OPEN-LOOP GAIN OF ONE MILLION WITH 500kHz BANDWIDTH. AS THE GAIN ERROR PLOT SHOWS, THIS DEVICE IS CAPABLE OF 0.1% AMPLIFYING ACCURACY UP TO 0.3Hz ONLY. EVEN INSTRUMENTATION RANGE SIGNALS CAN VARY AT A FASTER RATE. THE LT1124/LT1125 "GAIN PRECISION — BANDWIDTH PRODUCT" IS 75 TIMES HIGHER, AS SHOWN.

1124/25 TA03

Gain Error vs Frequency Closed-Loop Gain = 1000

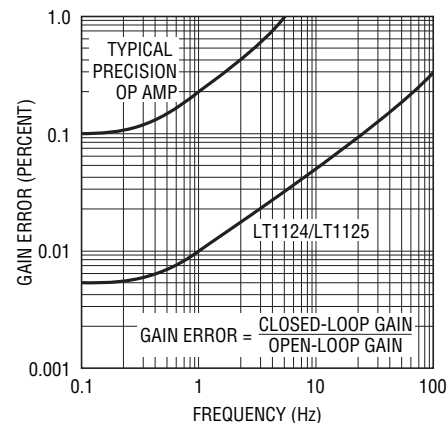

1124/25 TA04

SCHEMATIC DIAGRAM (1/2 LT1124, 1/4 LT1125)

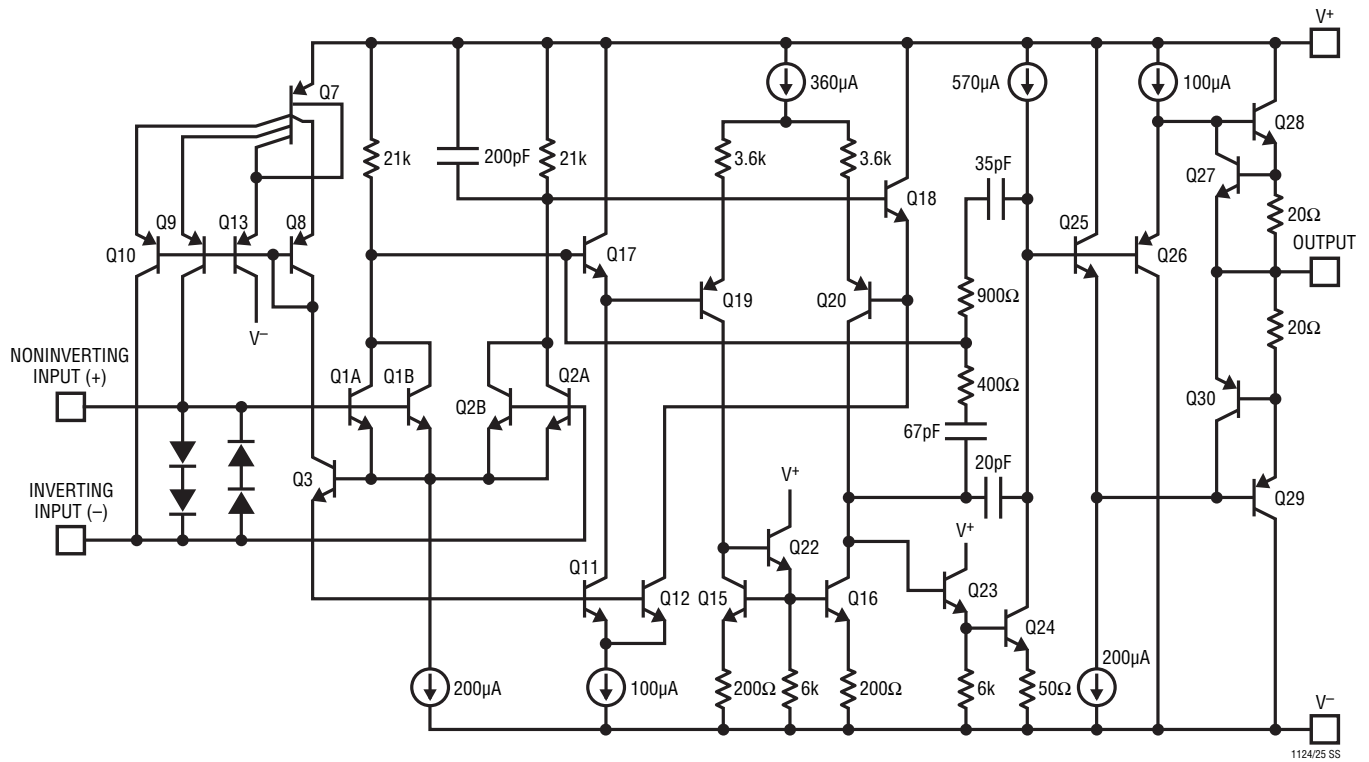

PACKAGE DESCRIPTION

Please refer to <http://www.linear.com/designtools/packaging/> for the most recent package drawings.

J8 Package 8-Lead CERDIP (Narrow .300 Inch, Hermetic) (Reference LTC DWG # 05-08-1110)

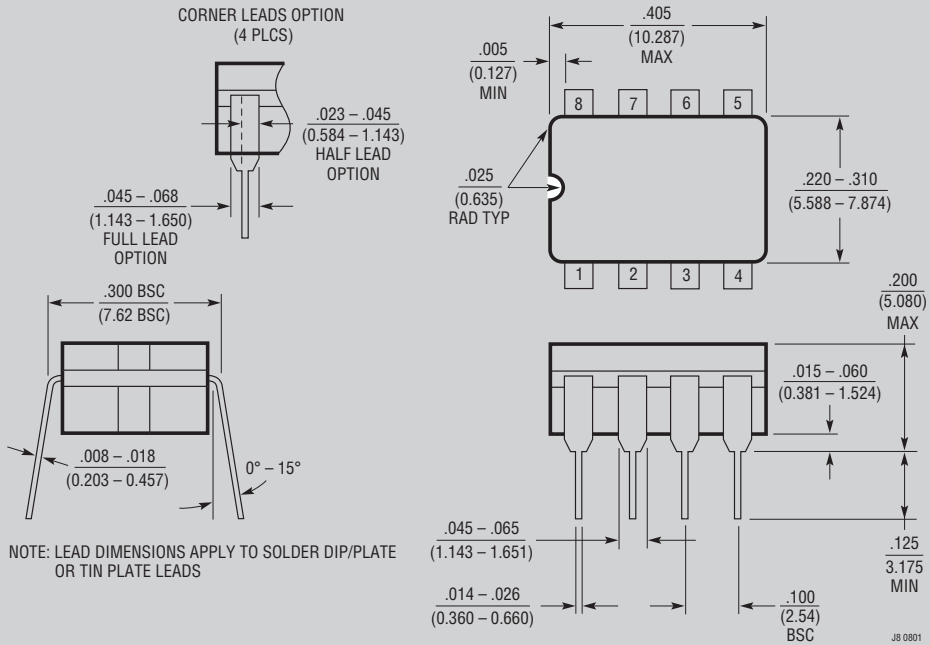

OBSOLETE PACKAGE

PACKAGE DESCRIPTION

Please refer to <http://www.linear.com/designtools/packaging/> for the most recent package drawings.

N8 Package 8-Lead PDIP (Narrow .300 Inch) (Reference LTC DWG # 05-08-1510 Rev I)



NOTE:
1. DIMENSIONS ARE $\frac{\text{INCHES}}{\text{MILLIMETERS}}$

*THESE DIMENSIONS DO NOT INCLUDE MOLD FLASH OR PROTRUSIONS.
MOLD FLASH OR PROTRUSIONS SHALL NOT EXCEED .010 INCH (0.254mm)

S8 Package 8-Lead Plastic Small Outline (Narrow .150 Inch) (Reference LTC DWG # 05-08-1610 Rev G)



RECOMMENDED SOLDER PAD LAYOUT

NOTE:
1. DIMENSIONS IN $\frac{\text{INCHES}}{\text{MILLIMETERS}}$
2. DRAWING NOT TO SCALE
3. THESE DIMENSIONS DO NOT INCLUDE MOLD FLASH OR PROTRUSIONS.
MOLD FLASH OR PROTRUSIONS SHALL NOT EXCEED .006" (0.15mm)
4. PIN 1 CAN BE BEVEL EDGE OR A DIMPLE

S08 REV G 0212

PACKAGE DESCRIPTION

Please refer to <http://www.linear.com/designtools/packaging/> for the most recent package drawings.

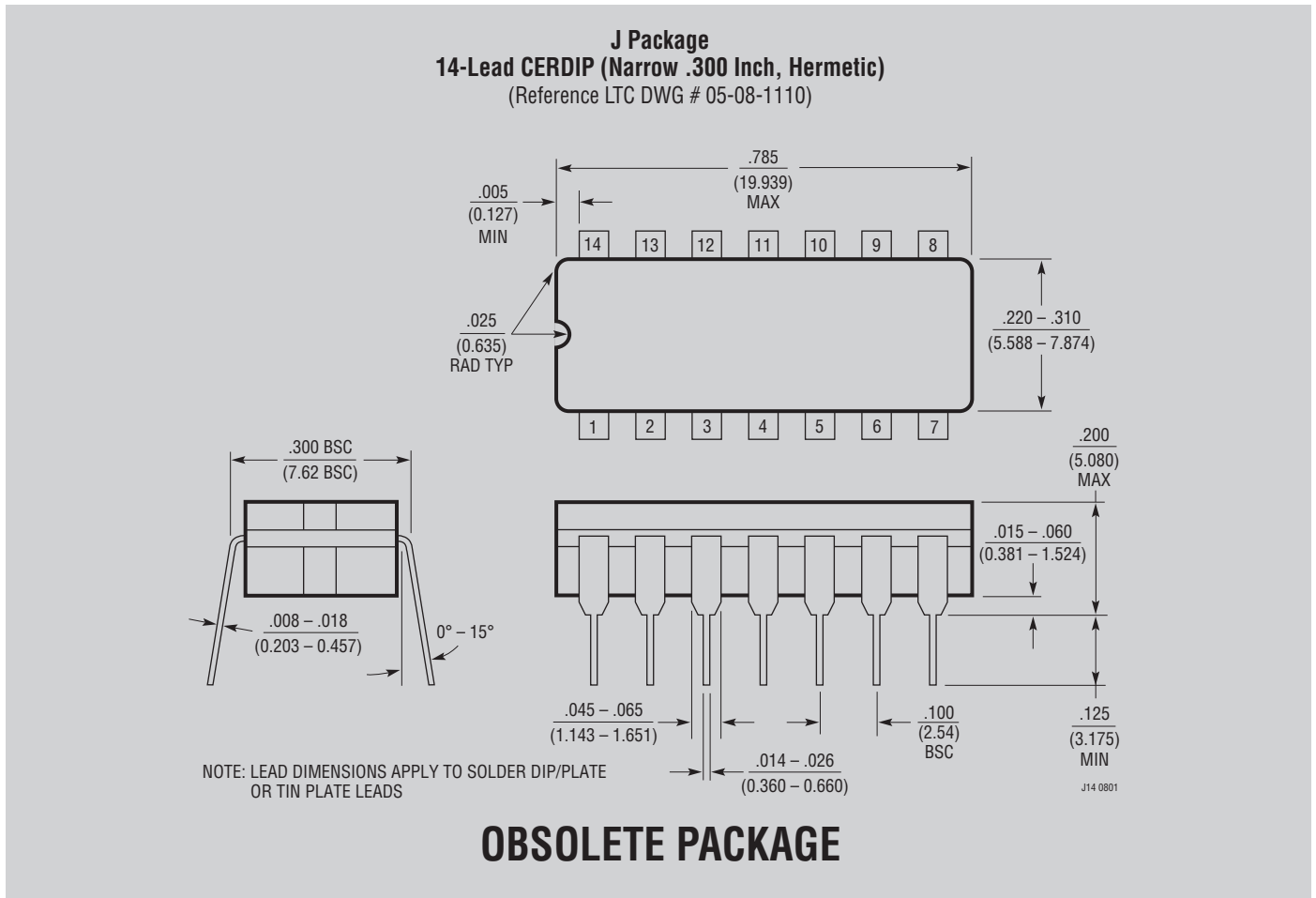

PACKAGE DESCRIPTION

Please refer to <http://www.linear.com/designtools/packaging/> for the most recent package drawings.

N Package
14-Lead PDIP (Narrow .300 Inch)
 (Reference LTC DWG # 05-08-1510 Rev I)

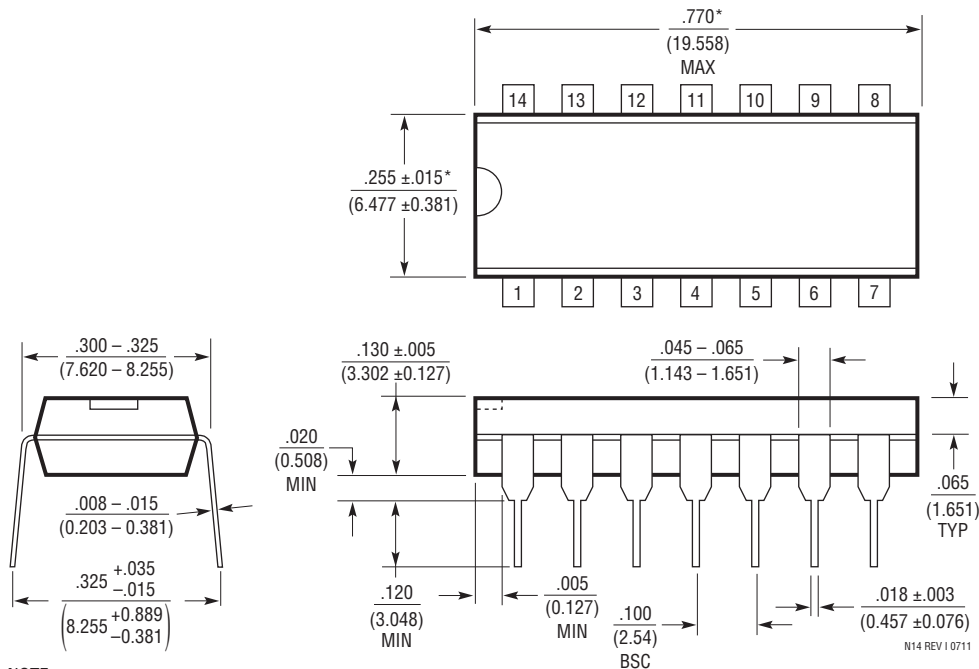

NOTE:
 1. DIMENSIONS ARE $\frac{\text{INCHES}}{\text{MILLIMETERS}}$
 *THESE DIMENSIONS DO NOT INCLUDE MOLD FLASH OR PROTRUSIONS.
 MOLD FLASH OR PROTRUSIONS SHALL NOT EXCEED .010 INCH (0.254mm)

PACKAGE DESCRIPTION

Please refer to <http://www.linear.com/designtools/packaging/> for the most recent package drawings.

SW Package 16-Lead Plastic Small Outline (Wide .300 Inch) (Reference LTC DWG # 05-08-1620)

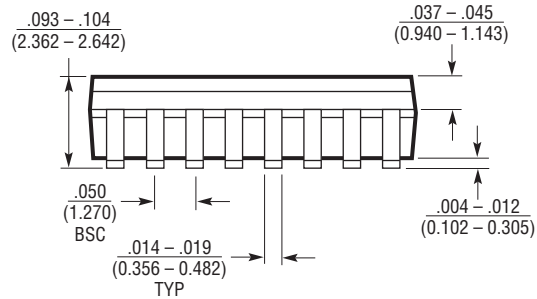
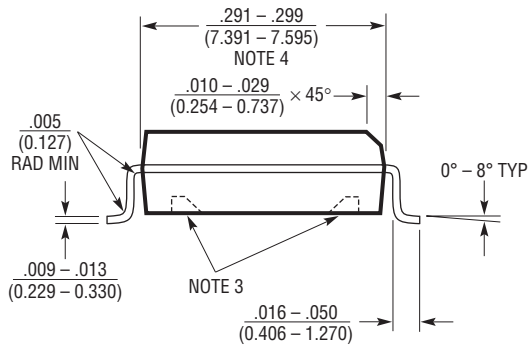
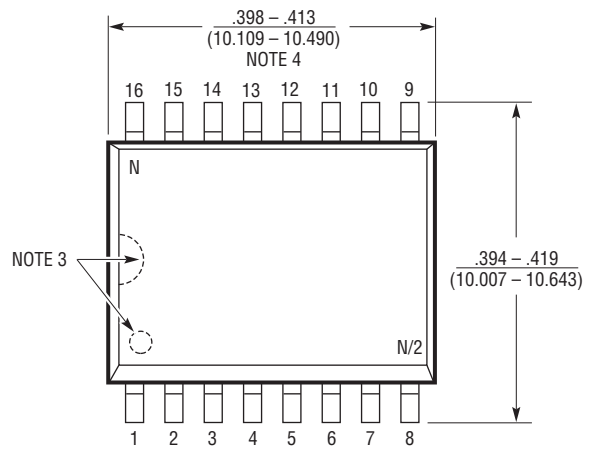
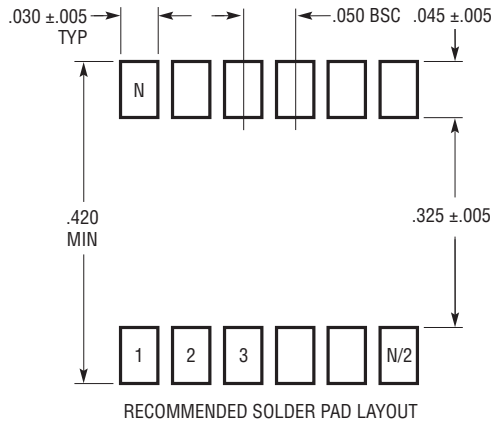

- NOTE:
1. DIMENSIONS IN $\frac{\text{INCHES}}{\text{MILLIMETERS}}$
 2. DRAWING NOT TO SCALE
 3. PIN 1 IDENT, NOTCH ON TOP AND CAVITIES ON THE BOTTOM OF PACKAGES ARE THE MANUFACTURING OPTIONS. THE PART MAY BE SUPPLIED WITH OR WITHOUT ANY OF THE OPTIONS
 4. THESE DIMENSIONS DO NOT INCLUDE MOLD FLASH OR PROTRUSIONS. MOLD FLASH OR PROTRUSIONS SHALL NOT EXCEED .006" (0.15mm)

S16 (WIDE) 0502

REVISION HISTORY (Revision history begins at Rev D)

| REV | DATE | DESCRIPTION | PAGE NUMBER |
|-----|-------|--|-------------|
| D | 09/10 | LT1124-1 added. Reflected throughout the data sheet. | 1 to 18 |
| E | 10/10 | Revised part marking for LT1124AMPS8-1 in Order Information section. | 3 |
| F | 01/14 | LT1124-1 removed. | 1 to 3 |

LT1124/LT1125

TYPICAL APPLICATION

Strain Gauge Signal Conditioner with Bridge Excitation

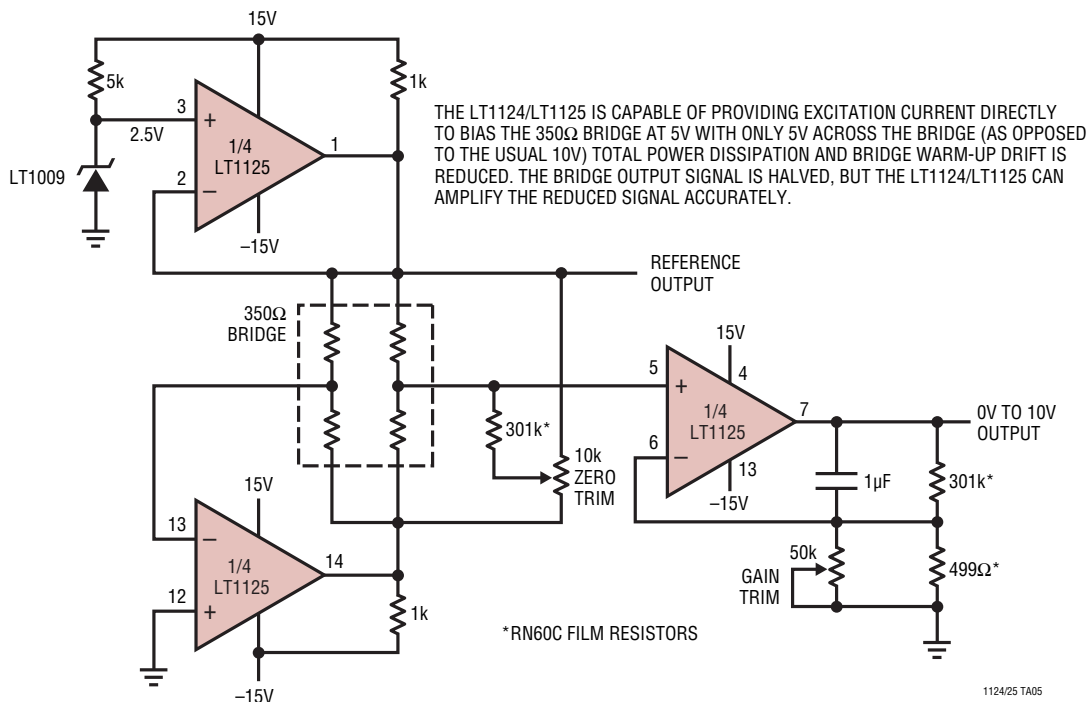

RELATED PARTS

| PART NUMBER | DESCRIPTION | COMMENTS |
|-------------------------------|-------------------------------------|---|
| LT1007 | Single Low Noise, Precision Op Amp | 2.5nV/√Hz 1kHz Voltage Noise |
| LT1028/LT1128 | Single Low Noise, Precision Op Amps | 0.85nV/√Hz Voltage Noise |
| LT1112/LT1114 | Dual/Quad Precision Picoamp Input | 250pA Max I _B |
| LT1113 | Dual Low Noise JFET Op Amp | 4.5nV/√Hz Voltage Noise, 10fA/√Hz Current Noise |
| LT1126/LT1127 | Decompensated LT1124/LT1125 | 11V/μs Slew Rate |
| LT1169 | Dual Low Noise JFET Op Amp | 6nV/√Hz Voltage Noise, 1fA/√Hz Current Noise, 10pA Max I _B |
| LT1792 | Single LT1113 | 4.2nV/√Hz Voltage Noise, 10fA/√Hz Current Noise |
| LT1793 | Single LT1169 | 6nV/√Hz Voltage Noise, 1fA/√Hz Current Noise, 10pA Max I _B |

11245ff



Компания «ЭлектроПласт» предлагает заключение долгосрочных отношений при поставках импортных электронных компонентов на взаимовыгодных условиях!

Наши преимущества:

- Оперативные поставки широкого спектра электронных компонентов отечественного и импортного производства напрямую от производителей и с крупнейших мировых складов;
- Поставка более 17-ти миллионов наименований электронных компонентов;
- Поставка сложных, дефицитных, либо снятых с производства позиций;
- Оперативные сроки поставки под заказ (от 5 рабочих дней);
- Экспресс доставка в любую точку России;
- Техническая поддержка проекта, помощь в подборе аналогов, поставка прототипов;
- Система менеджмента качества сертифицирована по Международному стандарту ISO 9001;
- Лицензия ФСБ на осуществление работ с использованием сведений, составляющих государственную тайну;
- Поставка специализированных компонентов (Xilinx, Altera, Analog Devices, Intersil, Interpoint, Microsemi, Aeroflex, Peregrine, Syfer, Eurofarad, Texas Instrument, Miteq, Cobham, E2V, MA-COM, Hittite, Mini-Circuits, General Dynamics и др.);

Помимо этого, одним из направлений компании «ЭлектроПласт» является направление «Источники питания». Мы предлагаем Вам помощь Конструкторского отдела:

- Подбор оптимального решения, техническое обоснование при выборе компонента;
- Подбор аналогов;
- Консультации по применению компонента;
- Поставка образцов и прототипов;
- Техническая поддержка проекта;
- Защита от снятия компонента с производства.



Как с нами связаться

Телефон: 8 (812) 309 58 32 (многоканальный)

Факс: 8 (812) 320-02-42

Электронная почта: org@eplast1.ru

Адрес: 198099, г. Санкт-Петербург, ул. Калинина, дом 2, корпус 4, литера А.