

BAROMETRIC AMPLIFIED PRESSURE SENSORS

600 to 1,100 mbar Barometric Pressure Sensor

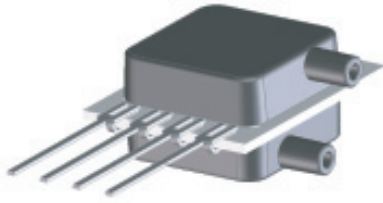

Features

- Barometric Pressure Range
- Temperature Compensated
- Calibrated Zero and Span

Applications

- Medical Instrumentation
- Environmental Monitoring
- Altimeters
- Chemical Analysis

General Description

The Miniature Amplified Output pressure sensors is based upon a proprietary technology to reduce all output offset or common mode errors. This model provides a calibrated amplified output with superior output offset characteristics. Output offset errors due to change in temperature, stability to warm-up, stability to long time period, and position sensitivity are all significantly reduced when compared to conventional compensation methods. In addition the sensor utilizes a silicon, micromachined, stress concentration enhanced structure to provide a very linear output to measured pressure.

These calibrated and temperature compensated sensors give an accurate and stable output over a wide temperature range. This series is intended for use with non-corrosive, non-ionic working fluids such as air, dry gases and the like.

The output of the device is ratiometric to the supply voltage and operation from any D.C. supply voltage between 4.5 and 5.5 volts.

Physical Dimensions

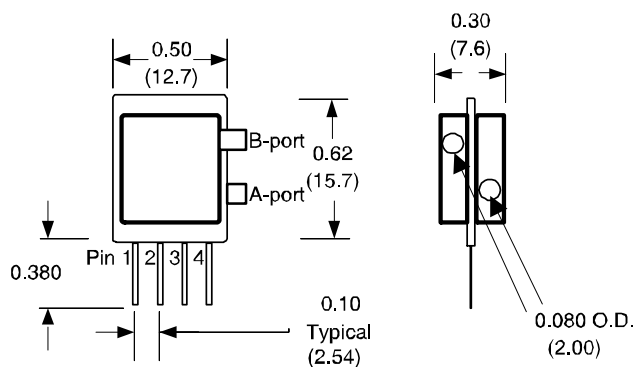

Approvals

MKT	DATE	MFG	DATE	ENG	DATE	QA	DATE
<input type="checkbox"/> As Is <input type="checkbox"/> With Change		<input type="checkbox"/> As Is <input type="checkbox"/> With Change		<input type="checkbox"/> As Is <input type="checkbox"/> With Change		<input type="checkbox"/> As Is <input type="checkbox"/> With Change	

Pressure Sensor Characteristics Maximum Ratings

Supply Voltage V_S	+4.5 to +5.5Vdc
Lead Temperature (soldering 2-4 sec.)	250°C

Environmental Specifications

Temperature Ranges	
Compensated	see specification
Operating	-25 to 85° C
Storage	-40 to 125° C
Humidity Limits	0 to 95% RH (non condensing)

Standard Pressure Ranges

Part Number	Operating Pressure	Compensated Range
BARO-A-4V-MINI	600 to 1,100 mbar	5 to 50° C
BARO-A-4V--MINI-PRIME	600 to 1,100 mbar	-25 to 85° C
BARO-A-4V-MINI-MIL	600 to 1,100 mbar	-40 to 125° C

Equivalent Circuit

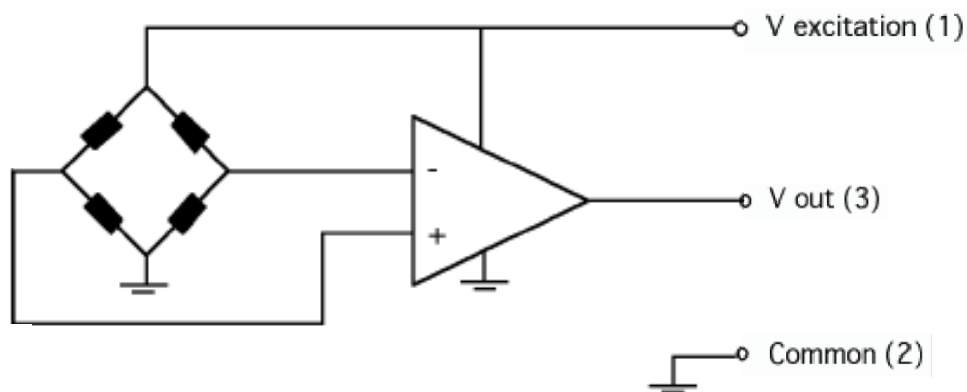

Performance Characteristics for BARO-A-4V-MINI

Parameter, note 1	Minimum	Nominal	Maximum	Units
Operating Range, absolute pressure	600		1100	mBar
Output Voltage @1,100 mbar	4.15	4.25	4.35	volt
Output Voltage @ 600 mbar	0.15	0.25	0.35	volt
Offset Temperature Shift (5°C to 50°C), note 2			±20	mvolt
Linearity, hysteresis error, note 4		0.05	0.50	%fs
Span Shift (5°C to 50°C), note 2			±1	%span

Performance Characteristics for BARO-A-4V-MINI-PRIME

Parameter, note 1	Minimum	Nominal	Maximum	Units
Operating Range, absolute pressure	600		1100	mBar
Output Voltage @1,100 mbar	4.15	4.25	4.35	volt
Output Voltage @ 600 mbar	0.15	0.25	0.35	volt
Offset Temperature Shift (-25°C to 85°C), note 2			±20	mvolt
Linearity, hysteresis error, note 4		0.05	0.50	%fs
Span Shift (-25°C to 85°C), note 2			±1	%span

Performance Characteristics for BARO-A-4V-MINI-MIL

Parameter, note 1	Minimum	Nominal	Maximum	Units
Operating Range, absolute pressure	600		1100	mBar
Output Voltage @1,100 mbar	4.15	4.25	4.35	volt
Output Voltage @ 600 mbar	0.15	0.25	0.35	volt
Offset Temperature Shift (-40°C to 125°C), note 2			±20	mvolt
Linearity, hysteresis error, note 4		0.05	0.50	%fs
Span Shift (-40°C to 125°C), note 3			±1	%span

Specification Notes

NOTE 1: ALL PARAMETERS ARE MEASURED AT 5.0 VOLT EXCITATION, FOR THE NOMINAL FULL SCALE PRESSURE AND ROOM TEMPERATURE UNLESS OTHERWISE SPECIFIED. PRESSURE MEASUREMENTS ARE WITH POSITIVE PRESSURE APPLIED TO THE B-PORT.

NOTE 2: SHIFT IS RELATIVE TO 25°C.

NOTE 3: MEASURED AT ONE-HALF FULL SCALE RATED PRESSURE USING BEST STRAIGHT LINE CURVE FIT.

All Sensors reserves the right to make changes to any products herein. All Sensors does not assume any liability arising out of the application or use of any product or circuit described herein, neither does it convey any license under its patent rights nor the rights of others.



Компания «ЭлектроПласт» предлагает заключение долгосрочных отношений при поставках импортных электронных компонентов на взаимовыгодных условиях!

Наши преимущества:

- Оперативные поставки широкого спектра электронных компонентов отечественного и импортного производства напрямую от производителей и с крупнейших мировых складов;
- Поставка более 17-ти миллионов наименований электронных компонентов;
- Поставка сложных, дефицитных, либо снятых с производства позиций;
- Оперативные сроки поставки под заказ (от 5 рабочих дней);
- Экспресс доставка в любую точку России;
- Техническая поддержка проекта, помощь в подборе аналогов, поставка прототипов;
- Система менеджмента качества сертифицирована по Международному стандарту ISO 9001;
- Лицензия ФСБ на осуществление работ с использованием сведений, составляющих государственную тайну;
- Поставка специализированных компонентов (Xilinx, Altera, Analog Devices, Intersil, Interpoint, Microsemi, Aeroflex, Peregrine, Syfer, Eurofarad, Texas Instrument, Miteq, Cobham, E2V, MA-COM, Hittite, Mini-Circuits, General Dynamics и др.);

Помимо этого, одним из направлений компании «ЭлектроПласт» является направление «Источники питания». Мы предлагаем Вам помощь Конструкторского отдела:

- Подбор оптимального решения, техническое обоснование при выборе компонента;
- Подбор аналогов;
- Консультации по применению компонента;
- Поставка образцов и прототипов;
- Техническая поддержка проекта;
- Защита от снятия компонента с производства.



Как с нами связаться

Телефон: 8 (812) 309 58 32 (многоканальный)

Факс: 8 (812) 320-02-42

Электронная почта: org@eplast1.ru

Адрес: 198099, г. Санкт-Петербург, ул. Калинина, дом 2, корпус 4, литера А.