

Features:

- ✓ 12 Volt / 12 Amp output
- ✓ Greater than 92% Efficient
- ✓ Full 144 Watt capability to more than 70 °C
- ✓ Output voltage trim capability
- ✓ Thermal and overload protection
- ✓ Microprocessor controlled supervisory functions
- ✓ Out-gassing feature ensures reliable pin soldering
- ✓ RoHS Compliant

OBSELETE PRODUCT

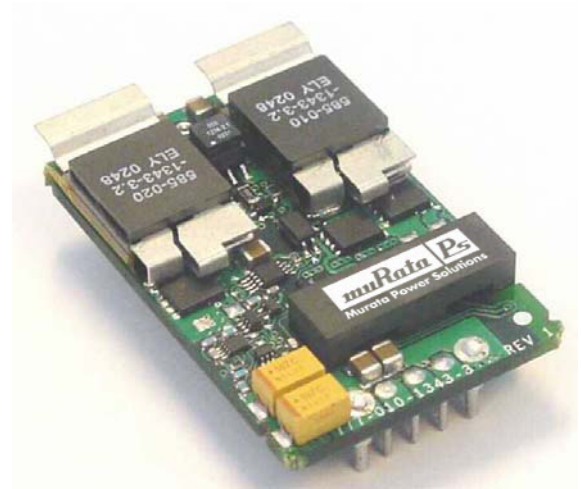

Table 1

Input Characteristics	Notes & Conditions (1)	Min	Typ.	Max	Units
Input Voltage Operating Range		36	48	75	Vdc
Input Voltage Transient Protection				100	Vdc
Input Undervoltage Lockout	Turn-on Threshold	32		35	Vdc
	Turn-off Threshold	31		34	Vdc
	Hysteresis Voltage		1		Vdc
Input Overvoltage Lockout	Turn-on Threshold	76		80	Vdc
	Turn-off Threshold	75		79	Vdc
	Hysteresis Voltage		1		Vdc
Input Current	Steady-State		3.3		A
No-Load Input Current	Enabled state		150		mA
Disabled Input Current	Disabled state				mA
Input Reflected Ripple Current (2)				25	mA p-p
Inrush Current Transient				0.1	A ² s
Enable Characteristics	Internal pull-up voltage, ref. to Vi(-)		5		Vdc
	Input Impedance, internal pull-up		100		kOhms
Enable – Negative Logic Version	On State range	-0.1		0.8	Vdc
Enable – Positive Logic Version	Off State range	-0.1		0.8	Vdc



For full details go to
www.murata-ps.com/rohs

Table 2

Output Characteristics	Notes & Conditions (1)	Min	Typ.	Max	Units
Output Voltage Set Point	Trim feature not used	11.88	12	12.12	Vdc
Output Line Regulation				0.2	%
Output Load Regulation				0.2	%
Output Voltage Total Regulation		11.8 1		12.1 9	Vdc
Output Ripple Voltage & Noise (3)	20 MHz Bandwidth		50	100	mV p-p
Output Current Operating Range		0		12	A
Efficiency	100% Load		93		%
Turn-On Time	Vin present: Enable to 90% Vout		13		ms
Start-up Inhibit Time	Enabled: Vin applied to 90% Vout		15		ms
Transient Response (4)	25% step, 0.1A/μs, ΔVo			200	mV
	Recovery Time			300	μs
Remote Sense Compensation Range (5), (6)	Of Output Voltage Set Point, typ.			+10	%
Output Voltage Trim Range (6)	Of Output Voltage Set Point, typ.	-20		+10	%
Maximum Output Capacitance			3,900		μF

Table 3

Protection Characteristics	Notes & Conditions (1)	Min	Typ.	Max	Units
Output Over-Current Shutdown	Non-Latching		14		A
	Re-start rate		3		s
Over Voltage Shutdown	Latching	14		15.2	Vdc
Over Temperature Shutdown (7)	Non-Latching		125		°C

Table 4

General Specifications	Notes & Conditions (1)	Min	Typ.	Max	Units
Isolation Voltage	Input to Output	1500			Vdc
Isolation Resistance	Input to Output	10			Mohm
Isolation Capacitance			6800		pF
Storage Temperature Range	Non-condensing	-40		125	°C
Thermal Measurement Location (TML) Temperature (9)	See mechanical drawing for location				
Operating Temperature Range	Measured at TML	-40		120	°C
Semiconductor Junction Temperature	Package Rating			150	°C
Material Flammability	UL 94V-0				
MTBF	Calculated (Bellcore TR-332)	1.2			10 ⁶ Hrs
	Demonstrated	tbd			10 ⁶ Hrs
Switching Frequency			350		kHz
Dimension (LxWxH)	2.28"L x 1.45" W x 0.47"H (57.91 x 36.83 x 11.8 mm)				
Weight					grams

Table 5

Standards Compliance	Notes & Conditions (8)
UL/CSA 60950	c-UL-us recognized (basic Insulation), UL File# E165113
TUV	(Bauart) certified

Notes:

- (1) $V_{in} = 48V_{dc}$, $T_a = 25\text{ }^{\circ}C$, Airflow = 200 LFM unless otherwise noted.
- (2) Input Reflected Ripple Current is specified when measured with the filter shown in Figure 7.
- (3) Output Ripple Voltage and noise is specified when measured with a 10uF tantalum and a 1uF ceramic capacitor at the converter output pins.
- (4) Transient response is specified without a capacitor at the output of the converter.
- (5) If remote sense is not required or used, the Sense(+) and Sense(-) pins must be connected to $V_o(+)$ and $V_o(-)$ respectively.
- (6) See 'Remote Sense' and 'Trim Feature' details regarding output voltage range limitations.
- (7) Thermal shutdown is monitored at the 'Thermal Measurement Location' (TML). See 'Mechanical Information' on page 4 for the thermal measurement location.
- (8) See 'Safety Considerations'.
- (9) De-rating curves are conducted in a controlled environment. End application testing is required to ensure the Thermal Measurement Location temperature is below the maximum specified.

Mechanical Information

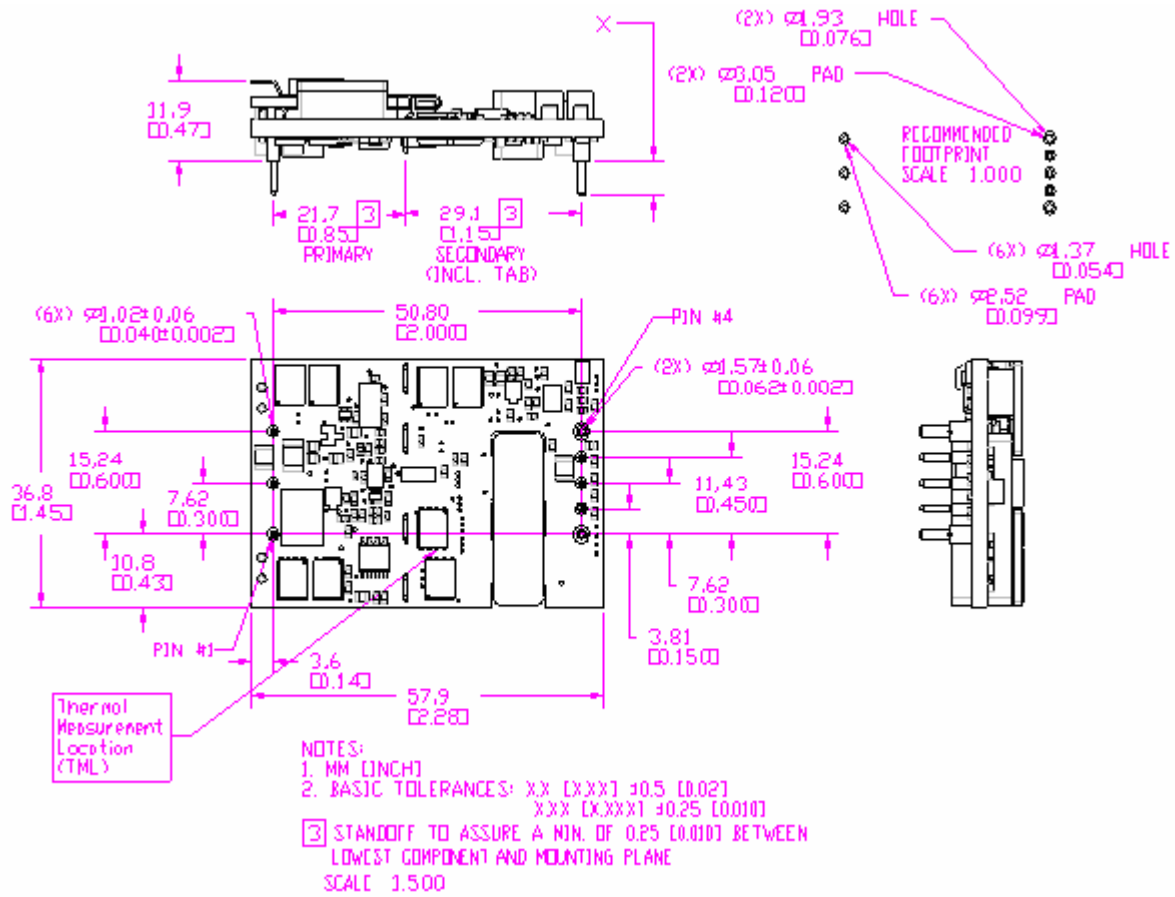

Figure 1

Pin Assignment

Table 6

Pin #	Pin Name	Function	Notes & Conditions
1	Vi(+)	Positive Input Voltage	
2	En	Input Enable / Disable	Referenced to Vo(-). No external source required. Positive Logic: Floating = Enabled Negative Logic: Floating = Disabled
3	Vi(-)	Negative Input Voltage	
4	Vo(-)	Negative Output Voltage	
5	Sense(-)	Negative Remote Sense	Must be connected to Vo(-)
6	Trim	Output Voltage Trim	See 'Trim Feature' below
7	Sense(+)	Positive Remote Sense	Must be connected to Vo(+)
8	Vo(+)	Positive Output Voltage	

Remote Sense

The remote sense regulates the output voltage across the sensing connections, and should be connected at the point on the board where regulation is desired. It is used to compensate for contact and distribution losses to the load. Efforts should be made to minimize these losses to help reduce noise and improve efficiency of the system.

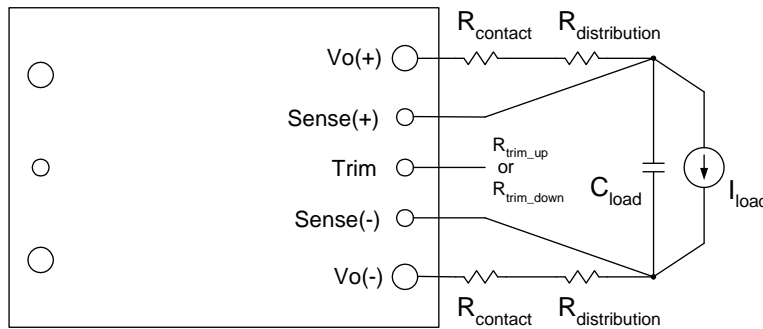

Figure 2

The voltage between remote sense pins and the output terminals must not exceed the output voltage sense range as specified in Table 2.

$$[Vo(+) - Vo(-)] - [Sense(+) - Sense(-)] \leq \text{Sense Range \%} \times \text{set point}$$

Trim-up Feature

The Trim-up configuration is used to increase the level of the nominal output voltage. This is achieved by connecting a resistor between Trim and Sense(+) pins:

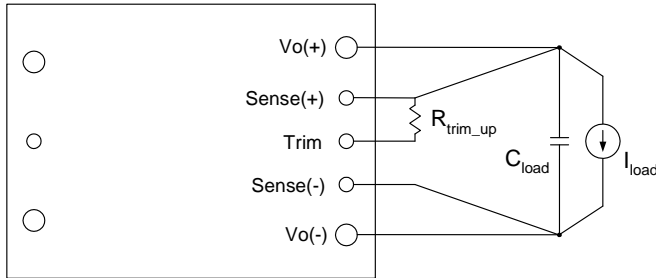

Figure 3

The value of the trim-up resistor is determined by the following equation:

$$R_{up}(V_{nom}, \Delta\%) := \left[5.11 \cdot V_{nom} \cdot \frac{(100 + \Delta\%)}{1.225 \cdot \Delta\%} \right] - \left\{ \frac{511}{\Delta\%} \right\} - 10.22$$

Vo: target output voltage

Vnom: nominal output voltage

Trim-down Feature

The Trim-down configuration is used to reduce the level of the nominal output voltage. Trim-down is achieved by connecting a resistor between Trim and Sense(-) pins:

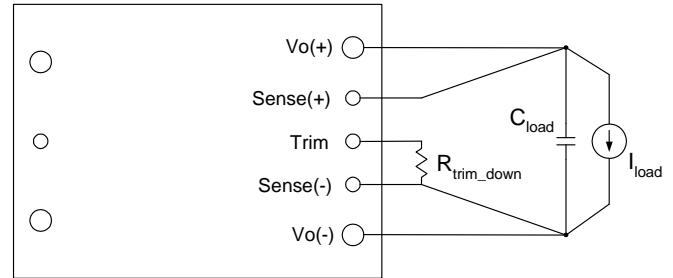
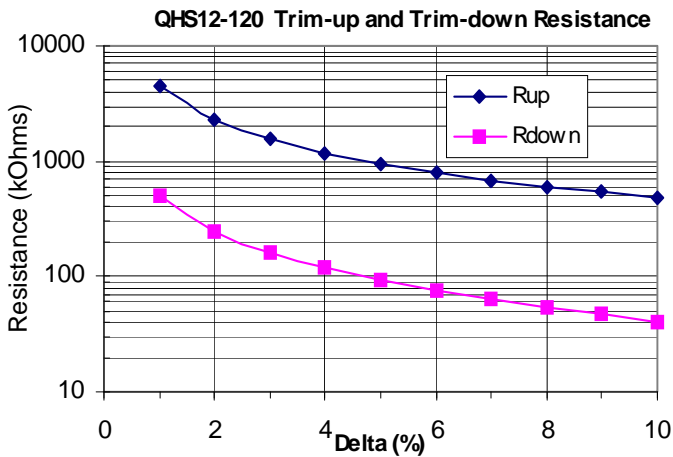

Figure 4

The value of the trim-down resistor is determined by the following equation:

$$R_{dwn}(\Delta\%) := \frac{511}{\Delta\%} - 10.22$$



The voltage between the Vo(+) and Vo(-) terminals must not exceed the minimum output over voltage shut-down value indicated in

Table 3. This limit includes any increase in voltage due to remote-sense compensation and output voltage set-point adjustment (trim).

The amount of power delivered by the module is defined as the voltage at the output terminals multiplied by the output current. (Output Voltage Set Point, typ x Output Current, Max) When using remote sense and/or trim, the output voltage of the module can be increased, and may result in an increase of output power. Care should be taken to ensure that the maximum output power of the module remains at or below the maximum rated power.

Efficiency Curves

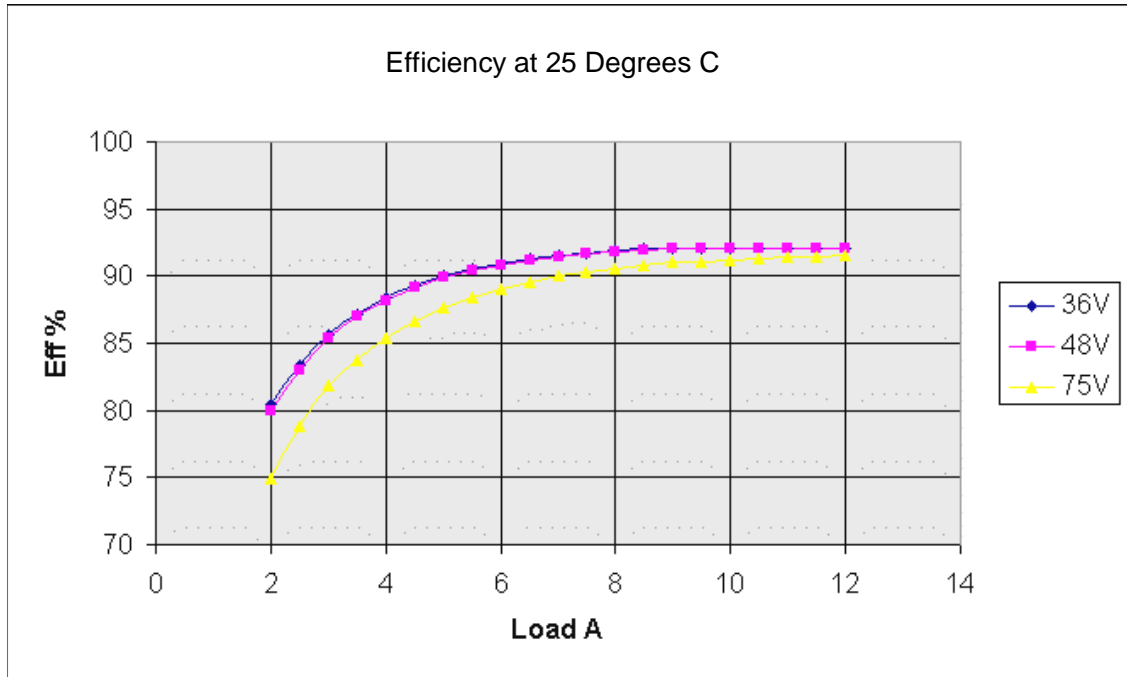

Figure 6 QHS12-120 Efficiency

Test Setup

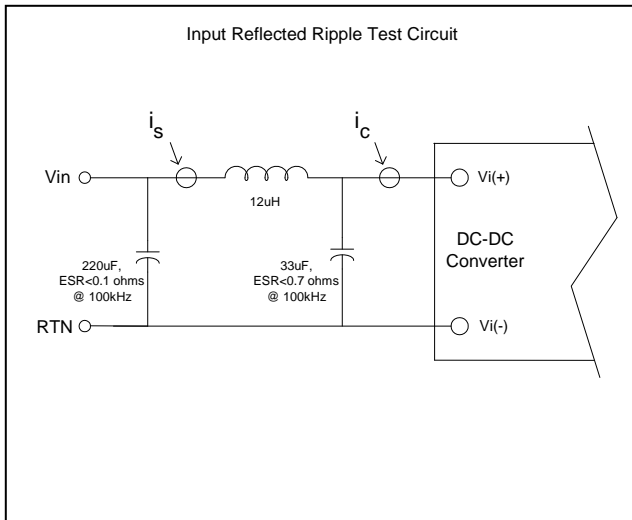

Figure 7 Test circuit used for input ripple current measurement

Input Reflected Ripple

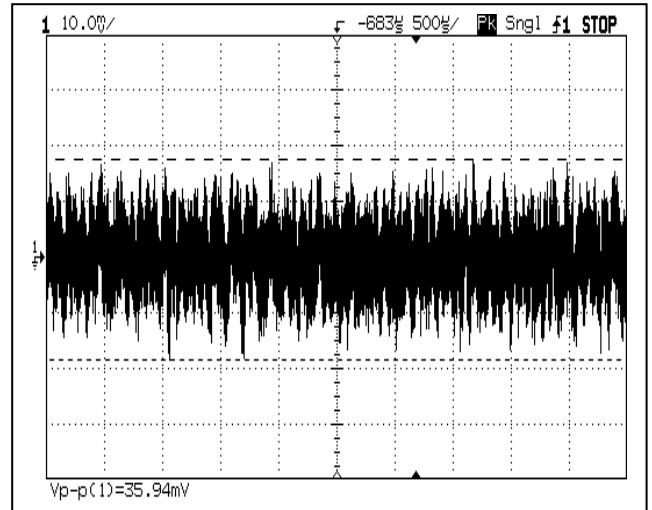

Figure 8 Input Current at full load, 48Vdc input. 5 mA/div, 500 μ s /div.

Output Ripple/Noise

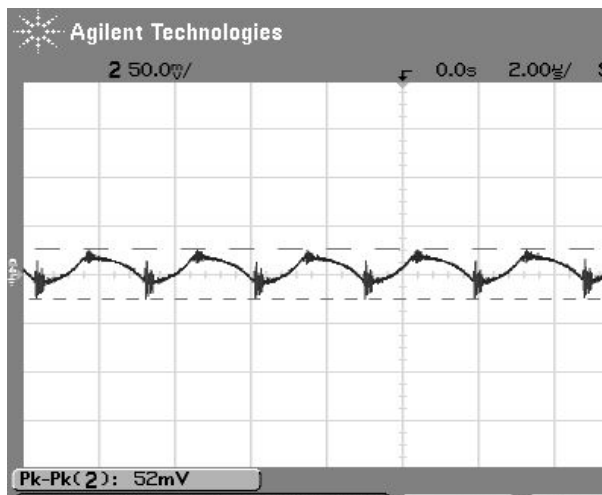

Figure 9 Output ripple: $V_{in}=48$ Vdc, $I_{out}=12$ Amps.
Vert: 50 mV/div. Horiz: 2 μ S/div

Load Transient +ve Step

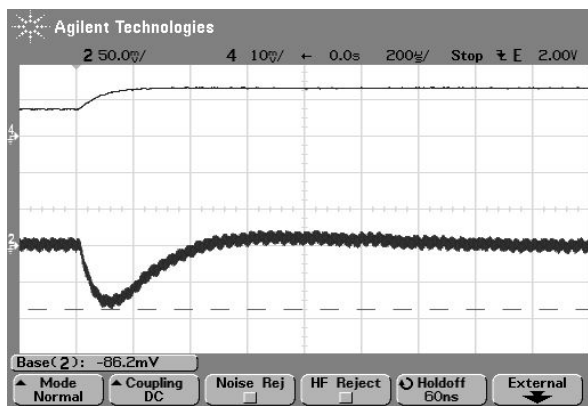

Figure 11 Top Trace: Load Current, 25% step, 5 A/div. Bottom Trace: V_{out} , 50 mV/div. Horiz: 200 μ S/div.

Load Transient -ve Step

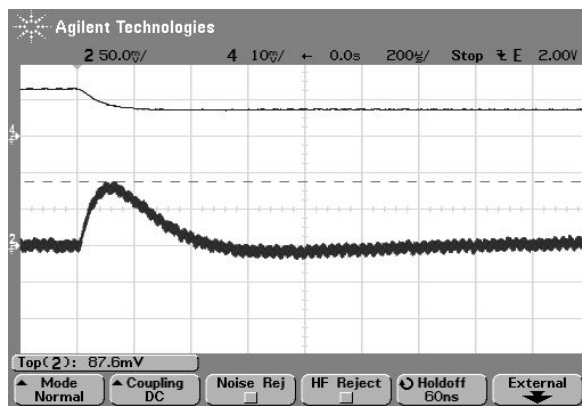

Figure 10 Top Trace: Load Current, 25% step, 5 A/div. Bottom Trace: V_{out} , 50 mV/div. Horiz: 200 μ S/div.

Thermal Derating (Parallel) $T_{TML}=110C$

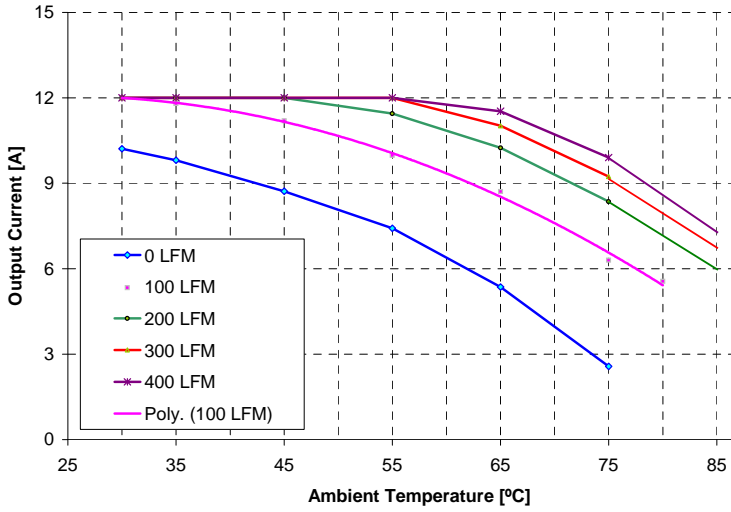

Figure 12

Thermal Derating (Transverse) $T_{TML}=110C$

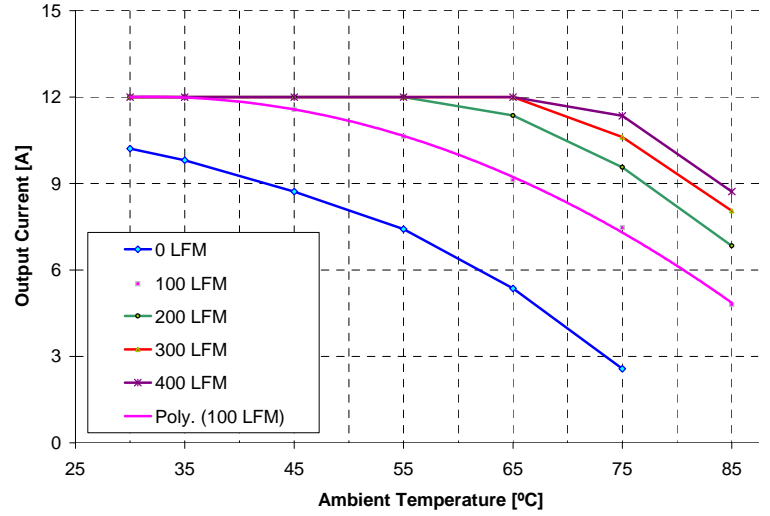

Figure 13

Thermal Derating (Parallel) $T_{TML}=120C$

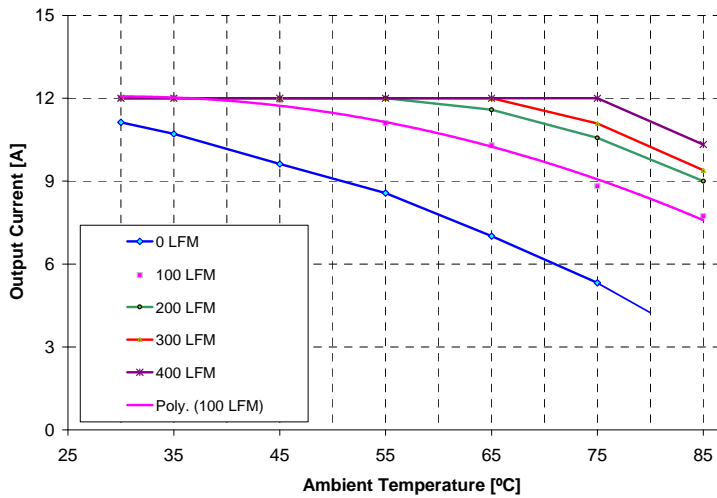

Figure 14

Thermal Derating (Transverse) $T_{TML}=120C$

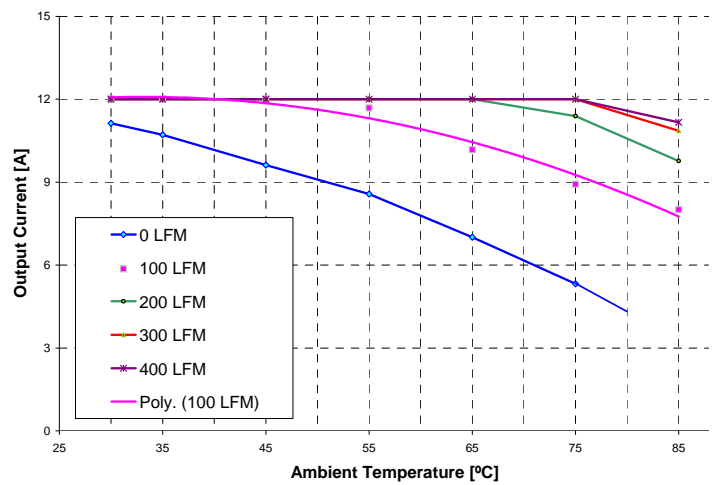

Figure 15

Thermal Image, 300 LFM, Output to Input

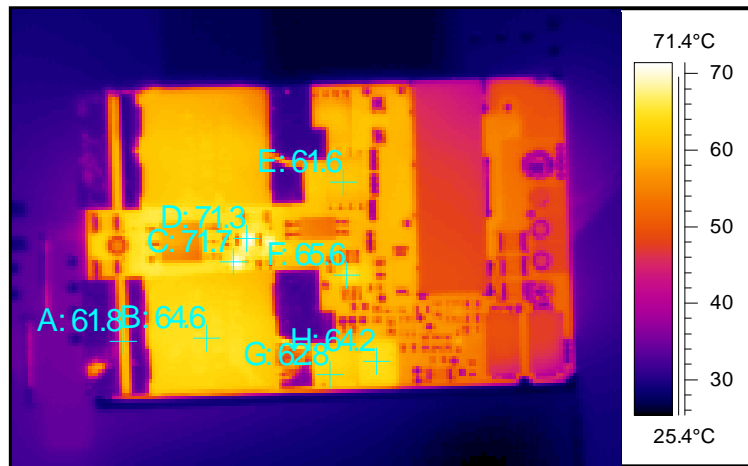

Figure 20 Parallel Airflow at 300 LFM, from output to input (right to left). Ambient Temperature 25 °C. Vin = 48 V, and load current of 12 amps.

Turn-on (Vout vs Vin)

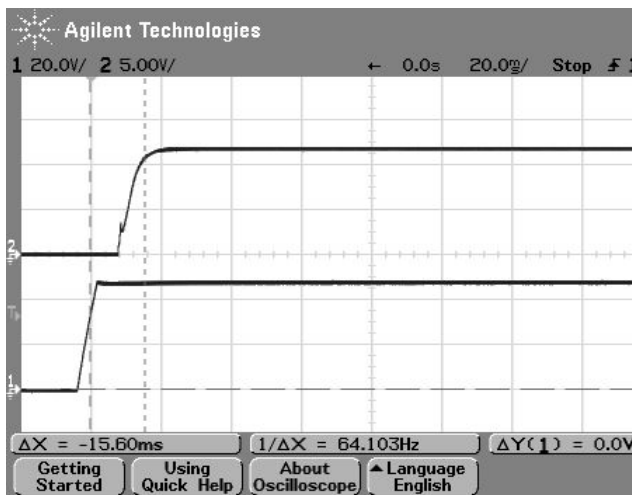

Figure 16 Converter pre-enabled, load = 12 Adc plus 3,900 uf, top trace(2): Vout, bottom trace (1): Vin from 0 to 48 Vdc.

Turn-on (Enable)

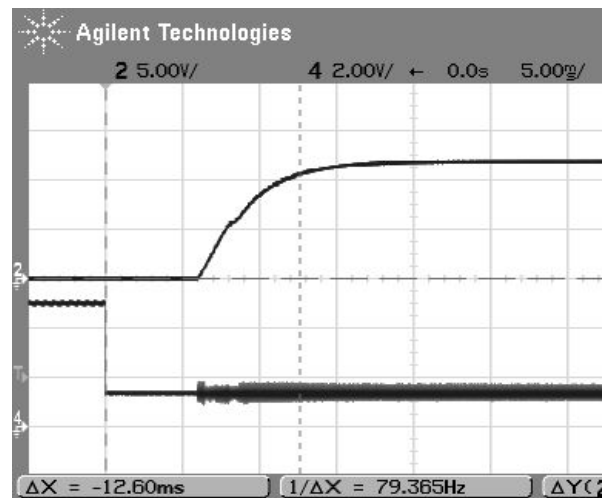

Figure 17 Vin: 48 Vdc, load = 12 Adc plus 3,900 uf, top trace (2): Vout, bottom trace (1): Enable Signal, transition from disable to enable.

EMI Signature

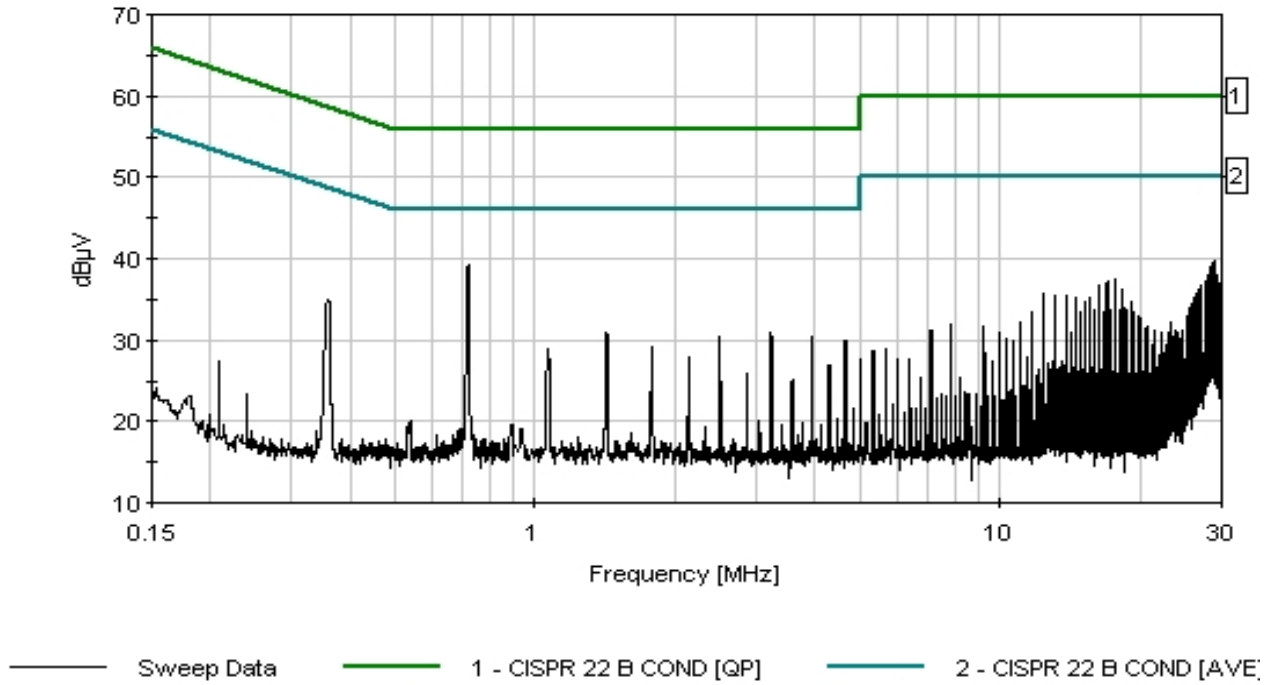

Figure 19 Quasi-Peak Measurement of positive input at 48Vdc and full load, with EMI filter as shown in Fig. 27.

External EMI Test Filter

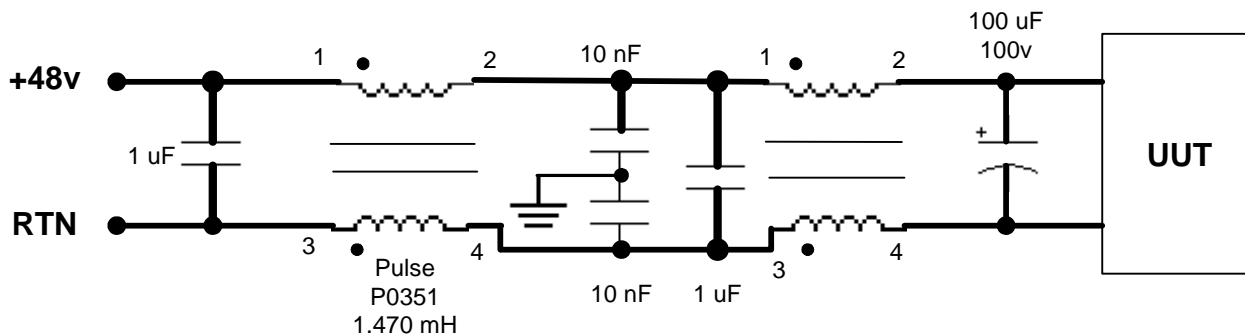

Figure 20 EMI Filter as used for EMI measurement of Fig. 26

Safety Considerations

This Product is certified to the standards listed in the 'Standards Compliance' section in the table above. If this product is built into information technology equipment, the installation must comply with the above standard.

An external input fuse of 30 A maximum must be used to meet the above requirements.
The output of the converter [Vo(+)/Vo(-)] is considered to remain within SELV limits when the input to the converter meets SELV or TNV-2 requirements.

The converters and materials meet UL 94V-0 flammability ratings.

Part Number Designations

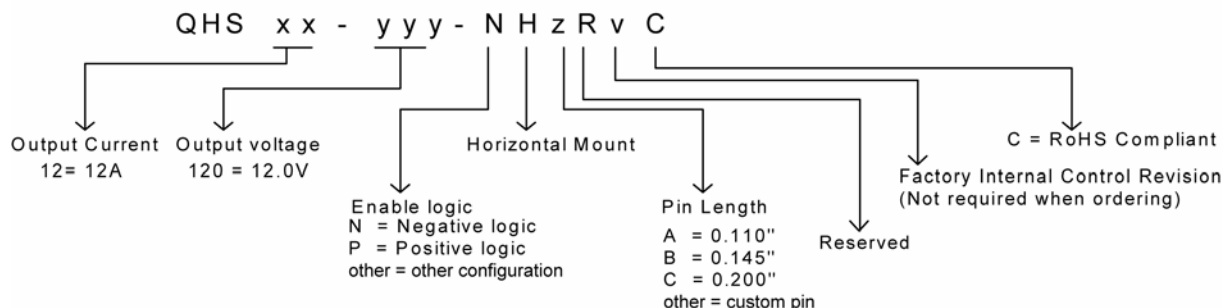

RoHS Compliant

The QHS12-120 series of converters is in compliance with the European Union Directive 2002/95/EC (RoHS) with respect to the following substances: lead (Pb), mercury (Hg), cadmium (Cd), hexavalent chromium, polybrominated biphenyls (PBB) or polybrominated diphenyl ethers (PBDE).

Murata Power Solutions, Inc.
11 Cabot Boulevard, Mansfield, MA 02048-1151 U.S.A.
ISO 9001 and 14001 REGISTERED



This product is subject to the following [operating requirements](#) and the [Life and Safety Critical Application Sales Policy](#):
Refer to: <http://www.murata-ps.com/requirements/>

Murata Power Solutions, Inc. makes no representation that the use of its products in the circuits described herein, or the use of other technical information contained herein, will not infringe upon existing or future patent rights. The descriptions contained herein do not imply the granting of licenses to make, use, or sell equipment constructed in accordance therewith. Specifications are subject to change without notice. © 2012 Murata Power Solutions, Inc.



Компания «ЭлектроПласт» предлагает заключение долгосрочных отношений при поставках импортных электронных компонентов на взаимовыгодных условиях!

Наши преимущества:

- Оперативные поставки широкого спектра электронных компонентов отечественного и импортного производства напрямую от производителей и с крупнейших мировых складов;
- Поставка более 17-ти миллионов наименований электронных компонентов;
- Поставка сложных, дефицитных, либо снятых с производства позиций;
- Оперативные сроки поставки под заказ (от 5 рабочих дней);
- Экспресс доставка в любую точку России;
- Техническая поддержка проекта, помощь в подборе аналогов, поставка прототипов;
- Система менеджмента качества сертифицирована по Международному стандарту ISO 9001;
- Лицензия ФСБ на осуществление работ с использованием сведений, составляющих государственную тайну;
- Поставка специализированных компонентов (Xilinx, Altera, Analog Devices, Intersil, Interpoint, Microsemi, Aeroflex, Peregrine, Syfer, Eurofarad, Texas Instrument, Miteq, Cobham, E2V, MA-COM, Hittite, Mini-Circuits, General Dynamics и др.);

Помимо этого, одним из направлений компании «ЭлектроПласт» является направление «Источники питания». Мы предлагаем Вам помощь Конструкторского отдела:

- Подбор оптимального решения, техническое обоснование при выборе компонента;
- Подбор аналогов;
- Консультации по применению компонента;
- Поставка образцов и прототипов;
- Техническая поддержка проекта;
- Защита от снятия компонента с производства.



Как с нами связаться

Телефон: 8 (812) 309 58 32 (многоканальный)

Факс: 8 (812) 320-02-42

Электронная почта: org@eplast1.ru

Адрес: 198099, г. Санкт-Петербург, ул. Калинина, дом 2, корпус 4, литера А.