



dsPIC33FJ32GS406/606/608/610 and dsPIC33FJ64GS406/606/608/610

16-Bit Digital Signal Controllers with High-Speed PWM, ADC and Comparators

Operating Conditions

- 3.0V to 3.6V, -40°C to +85°C, DC to 50 MIPS
- 3.0V to 3.6V, -40°C to +125°C, DC to 40 MIPS

Core: 16-Bit dsPIC33F

- Code-Efficient (C and Assembly) Architecture
- Two 40-Bit Wide Accumulators
- Single-Cycle (MAC/MPY) with Dual Data Fetch
- Single-Cycle Mixed-Sign MUL plus Hardware Divide
- 32-Bit Multiply Support

Clock Management

- $\pm 1\%$ Internal Oscillator
- Programmable PLLs and Oscillator Clock Sources
- Fail-Safe Clock Monitor (FSCM)
- Independent Watchdog Timer (WDT)
- Fast Wake-up and Start-up

Power Management

- Low-Power Management modes (Sleep, Idle, Doze)
- Integrated Power-on Reset and Brown-out Reset
- 1.7 mA/MHz Dynamic Current (typical)
- 50 μ A IPD Current (typical)

High-Speed PWM

- Up to 9 PWM Pairs with Independent Timing
- Dead Time for Rising and Falling Edges
- 1.04 ns PWM Resolution
- PWM Support for:
 - DC/DC, AC/DC, Inverters, PFC, Lighting
 - BLDC, PMSM, ACIM, SRM
- Programmable Fault Inputs
- Flexible Trigger Configurations for ADC Conversions

Advanced Analog Features

- High-Speed ADC module:
 - 10-bit resolution with up to two Successive Approximation Register (SAR) converters (up to 4 Msps)
 - Up to 24 input channels grouped into 12 conversion pairs plus two voltage reference monitoring inputs
 - Dedicated result buffer for each analog channel
- Flexible and Independent ADC Trigger Sources
- Up to 4 High-Speed Comparators with Direct Connection to the PWM module:
 - 10-bit Digital-to-Analog Converter (DAC) for each comparator
 - DAC reference output
 - Programmable references with 1024 voltage points

Timers/Output Compare/Input Capture

- Six General Purpose Timers:
 - Five 16-bit and up to two 32-bit timers/counters
- Four Output Compare (OC) modules Configurable as Timers/Counters
- Quadrature Encoder Interface (QEI) module Configurable as Timer/Counter
- Four Input Capture (IC) modules

Communication Interfaces

- Two UART modules (12.5 Mbps):
 - With support for LIN/J2602 2.0 protocols and IrDA®
- Two 4-wire SPI modules (15 Mbps)
- ECAN™ module (1 Mbaud) CAN 2.0B Support
- Two I²C™ modules (up to 1 Mbaud) with SMBus Support

Direct Memory Access (DMA)

- 4-Channel DMA with User-Selectable Priority Arbitration
- UART, SPI, ECAN™, IC, OC and Timers

Input/Output

- Sink/Source 18 mA on 18 Pins, 10 mA on 1 Pin or 6 mA on 66 Pins
- 5V Tolerant Pins
- Selectable Open-Drain and Pull-ups
- 29 External Interrupts

Qualification and Class B Support

- AEC-Q100 REVG (Grade 1 -40°C to +125°C)
- Class B Safety Library, IEC 60730, VDE Certified

Debugger Development Support

- In-Circuit and In-Application Programming
- Two Program and two Complex Data Breakpoints
- IEEE 1149.2 Compatible (JTAG) Boundary Scan
- Trace and Run-Time Watch

dsPIC33FJ32GS406/606/608/610 and dsPIC33FJ64GS406/606/608/610

dsPIC33FJ32GS406/606/608/610 and dsPIC33FJ64GS406/606/608/610 PRODUCT FAMILIES

The device names, pin counts, memory sizes, and peripheral availability of each device are listed in [Table 1](#). The following pages show their pinout diagrams.

**TABLE 1: dsPIC33FJ32GS406/606/608/610 and dsPIC33FJ64GS406/606/608/610
CONTROLLER FAMILIES**

| Device | Pins | Program Flash Memory (Kbytes) | RAM (Bytes) | 16-Bit Timer | Input Capture | Output Compare | UART | Quadrature Encoder Interface | SPI | ECAN™ | DMA Channels | PWM | Analog Comparator | External Interrupts | DAC Output | I ² C™ | ADC | | | I/O Pins | Packages |
|------------------|------|-------------------------------|-------------------|--------------|---------------|----------------|------|------------------------------|-----|-------|--------------|-----|-------------------|---------------------|------------|-------------------|------|-------------------------------|--------------------------|----------|----------|
| | | | | | | | | | | | | | | | | | SARs | Sample-and-Hold (S&H) Circuit | Analog-to-Digital Inputs | | |
| dsPIC33FJ32GS406 | 64 | 32 | 4K | 5 | 4 | 4 | 2 | 1 | 2 | 0 | 0 | 6x2 | 0 | 5 | 0 | 2 | 1 | 5 | 16 | 58 | PT, MR |
| dsPIC33FJ32GS606 | 64 | 32 | 4K | 5 | 4 | 4 | 2 | 2 | 2 | 0 | 0 | 6x2 | 4 | 5 | 1 | 2 | 2 | 6 | 16 | 58 | PT, MR |
| dsPIC33FJ32GS608 | 80 | 32 | 4K | 5 | 4 | 4 | 2 | 2 | 2 | 0 | 0 | 8x2 | 4 | 5 | 1 | 2 | 2 | 6 | 18 | 74 | PT |
| dsPIC33FJ32GS610 | 100 | 32 | 4K | 5 | 4 | 4 | 2 | 2 | 2 | 0 | 0 | 9x2 | 4 | 5 | 1 | 2 | 2 | 6 | 24 | 85 | PT, PF |
| dsPIC33FJ64GS406 | 64 | 64 | 8K | 5 | 4 | 4 | 2 | 1 | 2 | 0 | 0 | 6x2 | 0 | 5 | 0 | 2 | 1 | 5 | 16 | 58 | PT, MR |
| dsPIC33FJ64GS606 | 64 | 64 | 9K ⁽¹⁾ | 5 | 4 | 4 | 2 | 2 | 2 | 1 | 4 | 6x2 | 4 | 5 | 1 | 2 | 2 | 6 | 16 | 58 | PT, MR |
| dsPIC33FJ64GS608 | 80 | 64 | 9K ⁽¹⁾ | 5 | 4 | 4 | 2 | 2 | 2 | 1 | 4 | 8x2 | 4 | 5 | 1 | 2 | 2 | 6 | 18 | 74 | PT |
| dsPIC33FJ64GS610 | 100 | 64 | 9K ⁽¹⁾ | 5 | 4 | 4 | 2 | 2 | 2 | 1 | 4 | 9x2 | 4 | 5 | 1 | 2 | 2 | 6 | 24 | 85 | PT, PF |

Note 1: RAM size is inclusive of 1-Kbyte DMA RAM.

Pin Diagrams



dsPIC33FJ32GS406/606/608/610 and dsPIC33FJ64GS406/606/608/610

Pin Diagrams (Continued)



Note: The metal plane at the bottom of the device is not connected to any pins and is recommended to be connected to Vss externally.

Pin Diagrams (Continued)

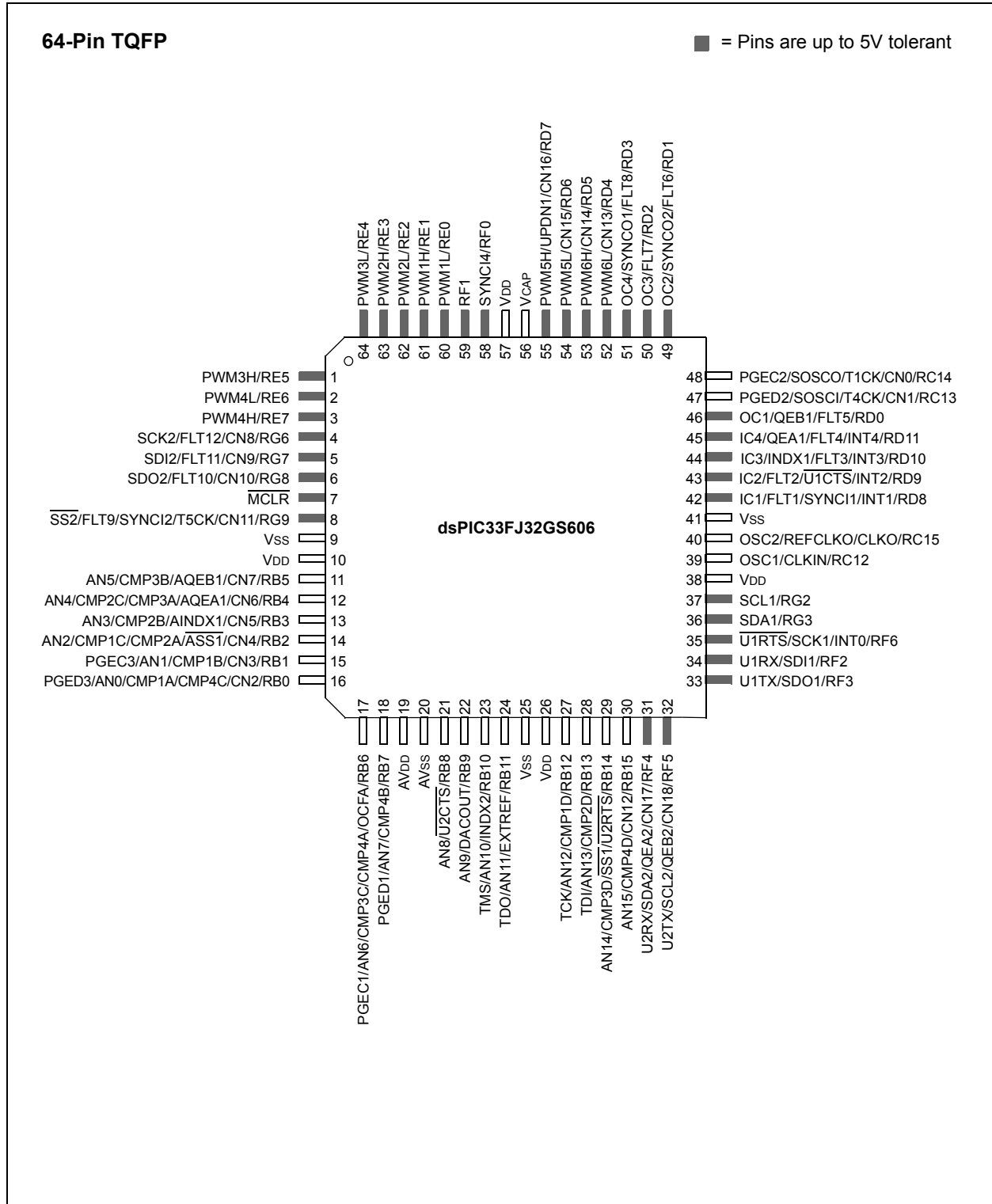

Pin Diagrams (Continued)



Pin Diagrams (Continued)



dsPIC33FJ32GS406/606/608/610 and dsPIC33FJ64GS406/606/608/610

Pin Diagrams (Continued)

64-Pin QFN

■ = Pins are up to 5V tolerant



Note: The metal plane at the bottom of the device is not connected to any pins and is recommended to be connected to Vss externally.

dsPIC33FJ32GS406/606/608/610 and dsPIC33FJ64GS406/606/608/610

Pin Diagrams (Continued)



Pin Diagrams (Continued)



Pin Diagrams (Continued)



Pin Diagrams (Continued)

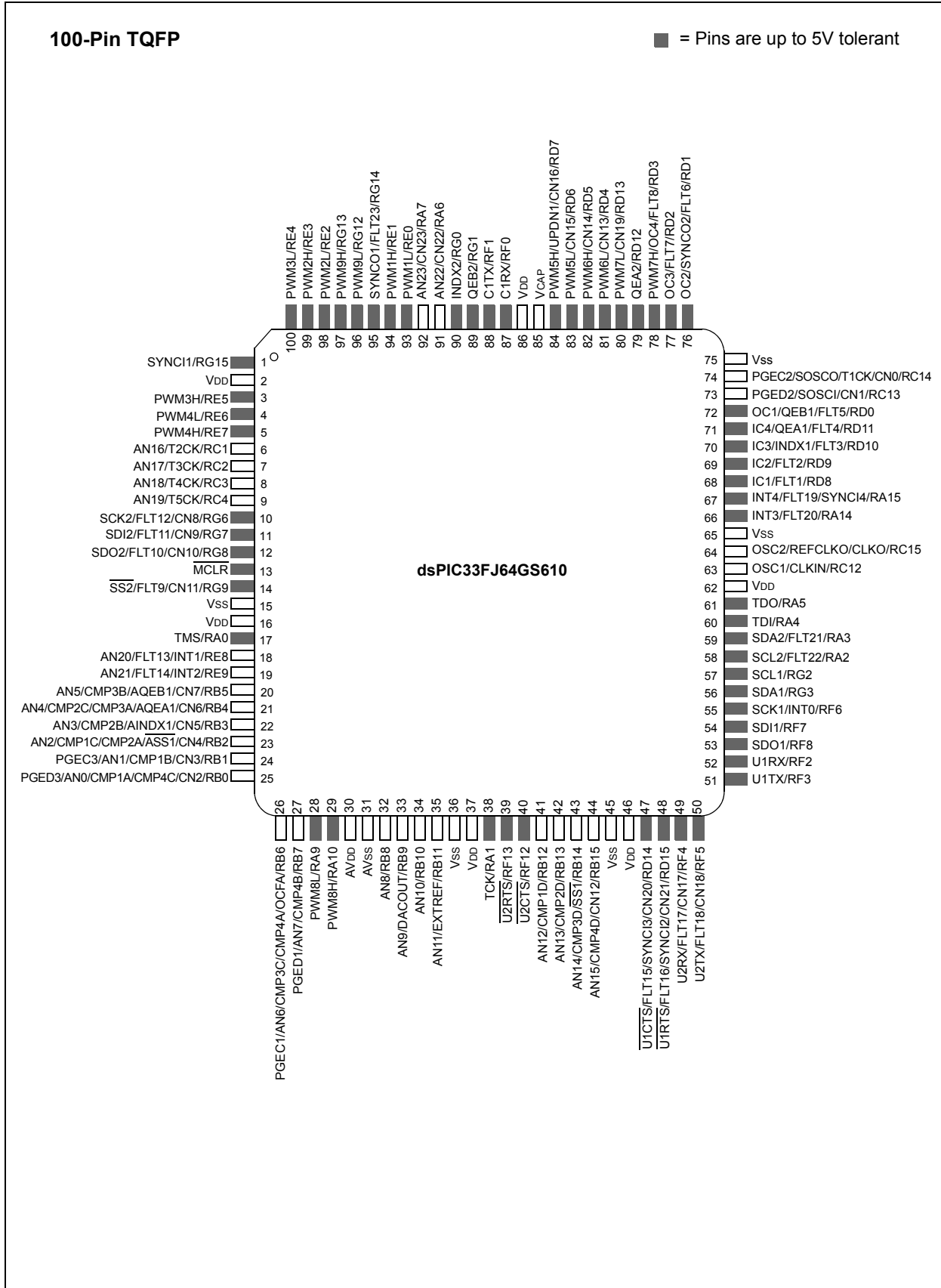

Table of Contents

| | |
|--|-----|
| dsPIC33FJ32GS406/606/608/610 and dsPIC33FJ64GS406/606/608/610 Product Families | 2 |
| 1.0 Device Overview | 17 |
| 2.0 Guidelines for Getting Started with 16-Bit Digital Signal Controllers | 23 |
| 3.0 CPU | 33 |
| 4.0 Memory Organization | 45 |
| 5.0 Flash Program Memory | 109 |
| 6.0 Resets | 115 |
| 7.0 Interrupt Controller | 123 |
| 8.0 Direct Memory Access (DMA) | 177 |
| 9.0 Oscillator Configuration | 187 |
| 10.0 Power-Saving Features | 201 |
| 11.0 I/O Ports | 211 |
| 12.0 Timer1 | 215 |
| 13.0 Timer2/3/4/5 features | 217 |
| 14.0 Input Capture | 223 |
| 15.0 Output Compare | 225 |
| 16.0 High-Speed PWM | 229 |
| 17.0 Quadrature Encoder Interface (QE1) Module | 257 |
| 18.0 Serial Peripheral Interface (SPI) | 261 |
| 19.0 Inter-Integrated Circuit (I ² C™) | 267 |
| 20.0 Universal Asynchronous Receiver Transmitter (UART) | 275 |
| 21.0 Enhanced CAN (ECAN™) Module | 281 |
| 22.0 High-Speed, 10-Bit Analog-to-Digital Converter (ADC) | 309 |
| 23.0 High-Speed Analog Comparator | 341 |
| 24.0 Special Features | 345 |
| 25.0 Instruction Set Summary | 353 |
| 26.0 Development Support | 361 |
| 27.0 Electrical Characteristics | 365 |
| 28.0 50 MIPS Electrical Characteristics | 413 |
| 29.0 DC and AC Device Characteristics Graphs | 421 |
| 30.0 Packaging Information | 423 |
| Appendix A: Migrating from dsPIC33FJ06GS101/X02 and dsPIC33FJ16GSX02/X04 to dsPIC33FJ32GS406/606/608/610 and dsPIC33FJ64GS406/606/608/610 Devices | 437 |
| Appendix B: Revision History | 438 |
| The Microchip Web Site | 451 |
| Customer Change Notification Service | 451 |
| Customer Support | 451 |
| Reader Response | 452 |
| Product Identification System | 453 |

TO OUR VALUED CUSTOMERS

It is our intention to provide our valued customers with the best documentation possible to ensure successful use of your Microchip products. To this end, we will continue to improve our publications to better suit your needs. Our publications will be refined and enhanced as new volumes and updates are introduced.

If you have any questions or comments regarding this publication, please contact the Marketing Communications Department via E-mail at docerrors@microchip.com or fax the **Reader Response Form** in the back of this data sheet to (480) 792-4150. We welcome your feedback.

Most Current Data Sheet

To obtain the most up-to-date version of this data sheet, please register at our Worldwide Web site at:

<http://www.microchip.com>

You can determine the version of a data sheet by examining its literature number found on the bottom outside corner of any page. The last character of the literature number is the version number, (e.g., DS30000A is version A of document DS30000).

Errata

An errata sheet, describing minor operational differences from the data sheet and recommended workarounds, may exist for current devices. As device/documentation issues become known to us, we will publish an errata sheet. The errata will specify the revision of silicon and revision of document to which it applies.

To determine if an errata sheet exists for a particular device, please check with one of the following:

- Microchip's Worldwide Web site; <http://www.microchip.com>
- Your local Microchip sales office (see last page)

When contacting a sales office, please specify which device, revision of silicon and data sheet (include literature number) you are using.

Customer Notification System

Register on our web site at www.microchip.com to receive the most current information on all of our products.

Referenced Sources

This device data sheet is based on the following individual chapters of the “*dsPIC33F/PIC24H Family Reference Manual*”. These documents should be considered as the primary reference for the operation of a particular module or device feature.

Note 1: To access the documents listed below, browse to the documentation section of the [dsPIC33FJ64GS610](#) product page of the Microchip web site (www.microchip.com) to select a family reference manual section from the following list.

In addition to parameters, features, and other documentation, the resulting page provides links to the related family reference manual sections.

- **Section 2. “CPU”** (DS70204)
- **Section 3. “Data Memory”** (DS70202)
- **Section 4. “Program Memory”** (DS70203)
- **Section 5. “Flash Programming”** (DS70191)
- **Section 8. “Reset”** (DS70192)
- **Section 9. “Watchdog Timer and Power-Saving Modes”** (DS70196)
- **Section 10. “I/O Ports”** (DS70193)
- **Section 11. “Timers”** (DS70205)
- **Section 12. “Input Capture”** (DS70198)
- **Section 13. “Output Compare”** (DS70209)
- **Section 15. “Quadrature Encoder Interface (QEI)”** (DS70208)
- **Section 16. “Analog-to-Digital Converter (ADC)”** (DS70183)
- **Section 17. “UART”** (DS70188)
- **Section 18. “Serial Peripheral Interface (SPI)”** (DS70206)
- **Section 19. “Inter-Integrated Circuit™ (I²C™)”** (DS70195)
- **Section 21. “Enhanced Controller Area Network (ECAN™)”** (DS70185)
- **Section 22. “Direct Memory Access (DMA)”** (DS70182)
- **Section 23. “CodeGuard Security”** (DS70199)
- **Section 24. “Programming and Diagnostics”** (DS70207)
- **Section 25. “Device Configuration”** (DS70194)
- **Section 26. “Development Tool Support”** (DS70200)
- **Section 42. “Oscillator (Part IV)”** (DS70307)
- **Section 43. “High-Speed PWM”** (DS70323)
- **Section 44. “High-Speed 10-Bit Analog-to-Digital Converter (ADC)”** (DS70321)
- **Section 45. “High-Speed Analog Comparator”** (DS70296)
- **Section 47. “Interrupts (Part V)”** (DS70597)

NOTES:

1.0 DEVICE OVERVIEW

Note: This data sheet summarizes the features of the dsPIC33FJ32GS406/606/608/610 and dsPIC33FJ64GS406/606/608/610 families of devices. It is not intended to be a comprehensive reference source. To complement the information in this data sheet, refer to the latest sections in the “*dsPIC33F/PIC24H Family Reference Manual*”, which are available from the Microchip web site (www.microchip.com).

The dsPIC33FJ32GS406/606/608/610 and dsPIC33FJ64GS406/606/608/610 families of devices contain extensive Digital Signal Processor (DSP) functionality with a high-performance 16-bit microcontroller (MCU) architecture.

Figure 1-1 shows a general block diagram of the core and peripheral modules in the dsPIC33FJ32GS406/606/608/610 and dsPIC33FJ64GS406/606/608/610 devices. Table 1-1 lists the functions of the various pins shown in the pinout diagrams.

This document contains device-specific information for the following dsPIC33F Digital Signal Controller (DSC) devices:

- dsPIC33FJ32GS406
- dsPIC33FJ32GS606
- dsPIC33FJ32GS608
- dsPIC33FJ32GS610
- dsPIC33FJ64GS406
- dsPIC33FJ64GS606
- dsPIC33FJ64GS608
- dsPIC33FJ64GS610

FIGURE 1-1: DEVICE BLOCK DIAGRAM

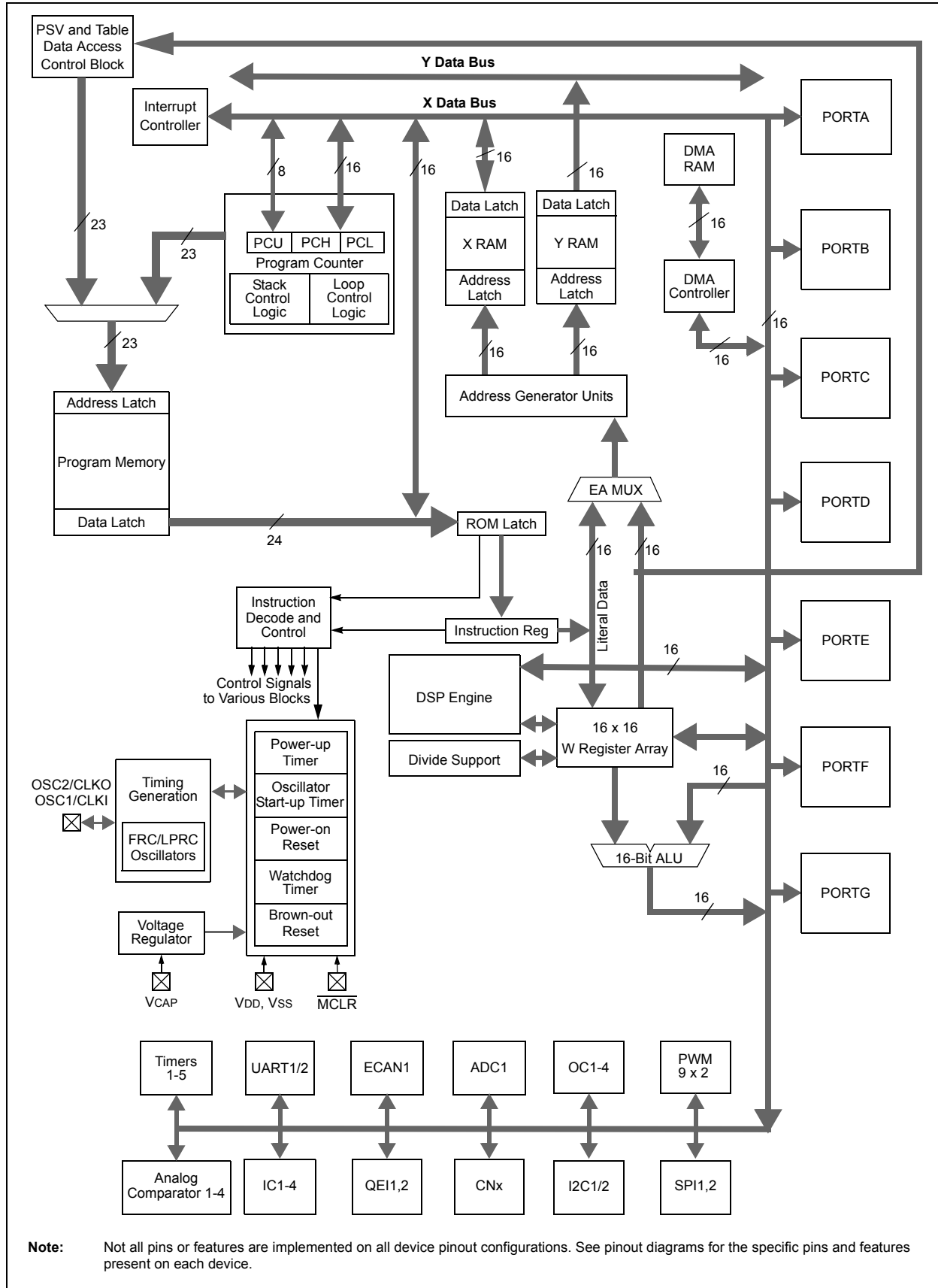

TABLE 1-1: PINOUT I/O DESCRIPTIONS

| Pin Name | Pin Type | Buffer Type | Description |
|---|-----------------------|----------------------------|--|
| AN0-AN23 | I | Analog | Analog input channels. |
| CLKI CLKO | I O | ST/CMOS — | External clock source input. Always associated with OSC1 pin function. Oscillator crystal output. Connects to crystal or resonator in Crystal Oscillator mode. Optionally functions as CLKO in RC and EC modes. Always associated with OSC2 pin function. |
| OSC1 OSC2 | I I/O | ST/CMOS — | Oscillator crystal input. ST buffer when configured in RC mode; CMOS otherwise. Oscillator crystal output. Connects to crystal or resonator in Crystal Oscillator mode. Optionally functions as CLKO in RC and EC modes. |
| SOSCI SOSCO | I O | ST/CMOS — | 32.768 kHz low-power oscillator crystal input; CMOS otherwise. 32.768 kHz low-power oscillator crystal output. |
| CN0-CN23 | I | ST | Change Notification inputs. Can be software programmed for internal weak pull-ups on all inputs. |
| C1RX C1TX | I O | ST — | ECAN1 bus receive pin. ECAN1 bus transmit pin. |
| IC1-IC4 | I | ST | Capture Inputs 1 through 4. |
| INDX1, INDX2, AINDX1 QEA1, QEA2, AQEA1 QEB1, QEB2, AQEB1 UPDN1 | I I I O | ST ST ST CMOS | Quadrature Encoder Index Pulse input. Quadrature Encoder Phase A input in QEI mode. Auxiliary Timer External Clock/Gate input in Timer mode. Quadrature Encoder Phase A input in QEI mode. Auxiliary Timer External Clock/Gate input in Timer mode. Position Up/Down Counter Direction State. |
| OCFA OC1-OC4 | I O | ST — | Compare Fault A input (for Compare Channels 1 and 2). Compare Outputs 1 through 4. |
| INT0 INT1 INT2 INT3 INT4 | I I I I I | ST ST ST ST ST | External Interrupt 0. External Interrupt 1. External Interrupt 2. External Interrupt 3. External Interrupt 4. |
| RA0-RA15 | I/O | ST | PORTA is a bidirectional I/O port. |
| RB0-RB15 | I/O | ST | PORTB is a bidirectional I/O port. |
| RC0-RC15 | I/O | ST | PORTC is a bidirectional I/O port. |
| RD0-RD15 | I/O | ST | PORTD is a bidirectional I/O port. |
| RE0-RE9 | I/O | ST | PORTE is a bidirectional I/O port. |
| RF0-RF13 | I/O | ST | PORTF is a bidirectional I/O port. |
| RG0-RG15 | I/O | ST | PORTG is a bidirectional I/O port. |
| T1CK T2CK T3CK T4CK T5CK | I I I I I | ST ST ST ST ST | Timer1 external clock input. Timer2 external clock input. Timer3 external clock input. Timer4 external clock input. Timer5 external clock input. |

Legend: CMOS = CMOS compatible input or output Analog = Analog input I = Input
 ST = Schmitt Trigger input with CMOS levels P = Power O = Output
 TTL = Transistor-Transistor Logic

dsPIC33FJ32GS406/606/608/610 and dsPIC33FJ64GS406/606/608/610

TABLE 1-1: PINOUT I/O DESCRIPTIONS (CONTINUED)

| Pin Name | Pin Type | Buffer Type | Description |
|-----------|----------|-------------|--|
| U1CTS | I | ST | UART1 Clear-to-Send. |
| U1RTS | O | — | UART1 Ready-to-Send. |
| U1RX | I | ST | UART1 receive. |
| U1TX | O | — | UART1 transmit. |
| U2CTS | I | ST | UART2 Clear-to-Send. |
| U2RTS | O | — | UART2 Ready-to-Send. |
| U2RX | I | ST | UART2 receive. |
| U2TX | O | — | UART2 transmit. |
| SCK1 | I/O | ST | Synchronous serial clock input/output for SPI1. |
| SDI1 | I | ST | SPI1 data in. |
| SDO1 | O | — | SPI1 data out. |
| SS1, ASS1 | I/O | ST | SPI1 slave synchronization or frame pulse I/O. |
| SCK2 | I/O | ST | Synchronous serial clock input/output for SPI2. |
| SDI2 | I | ST | SPI2 data in. |
| SDO2 | O | — | SPI2 data out. |
| SS2 | I/O | ST | SPI2 slave synchronization or frame pulse I/O. |
| SCL1 | I/O | ST | Synchronous serial clock input/output for I2C1. |
| SDA1 | I/O | ST | Synchronous serial data input/output for I2C1. |
| SCL2 | I/O | ST | Synchronous serial clock input/output for I2C2. |
| SDA2 | I/O | ST | Synchronous serial data input/output for I2C2. |
| TMS | I | TTL | JTAG Test mode select pin. |
| TCK | I | TTL | JTAG test clock input pin. |
| TDI | I | TTL | JTAG test data input pin. |
| TDO | O | — | JTAG test data output pin. |
| CMP1A | I | Analog | Comparator 1 Channel A. |
| CMP1B | I | Analog | Comparator 1 Channel B. |
| CMP1C | I | Analog | Comparator 1 Channel C. |
| CMP1D | I | Analog | Comparator 1 Channel D. |
| CMP2A | I | Analog | Comparator 2 Channel A. |
| CMP2B | I | Analog | Comparator 2 Channel B. |
| CMP2C | I | Analog | Comparator 2 Channel C. |
| CMP2D | I | Analog | Comparator 2 Channel D. |
| CMP3A | I | Analog | Comparator 3 Channel A. |
| CMP3B | I | Analog | Comparator 3 Channel B. |
| CMP3C | I | Analog | Comparator 3 Channel C. |
| CMP3D | I | Analog | Comparator 3 Channel D. |
| CMP4A | I | Analog | Comparator 4 Channel A. |
| CMP4B | I | Analog | Comparator 4 Channel B. |
| CMP4C | I | Analog | Comparator 4 Channel C. |
| CMP4D | I | Analog | Comparator 4 Channel D. |
| DACOUT | O | — | DAC output voltage. |
| EXTREF | I | Analog | External voltage reference input for the reference DACs. |
| REFCLK | O | — | REFCLK output signal is a postscaled derivative of the system clock. |

Legend: CMOS = CMOS compatible input or output Analog = Analog input I = Input
 ST = Schmitt Trigger input with CMOS levels P = Power O = Output
 TTL = Transistor-Transistor Logic

TABLE 1-1: PINOUT I/O DESCRIPTIONS (CONTINUED)

| Pin Name | Pin Type | Buffer Type | Description |
|---------------|----------|-------------|--|
| FLT1-FLT23 | I | ST | Fault inputs to PWM module. |
| SYNCI1-SYNCI4 | I | ST | External synchronization signal to PWM master time base. |
| SYNCO1-SYNCO2 | O | — | PWM master time base for external device synchronization. |
| PWM1L | O | — | PWM1 low output. |
| PWM1H | O | — | PWM1 high output. |
| PWM2L | O | — | PWM2 low output. |
| PWM2H | O | — | PWM2 high output. |
| PWM3L | O | — | PWM3 low output. |
| PWM3H | O | — | PWM3 high output. |
| PWM4L | O | — | PWM4 low output. |
| PWM4H | O | — | PWM4 high output. |
| PWM5L | O | — | PWM5 low output. |
| PWM5H | O | — | PWM5 high output. |
| PWM6L | O | — | PWM6 low output. |
| PWM6H | O | — | PWM6 high output. |
| PWM7L | O | — | PWM7 low output. |
| PWM7H | O | — | PWM7 high output. |
| PWM8L | O | — | PWM8 low output. |
| PWM8H | O | — | PWM8 high output. |
| PWM9L | O | — | PWM9 low output. |
| PWM9H | O | — | PWM9 high output. |
| PGED1 | I/O | ST | Data I/O pin for Programming/Debugging Communication Channel 1. |
| PGEC1 | I | ST | Clock input pin for Programming/Debugging Communication Channel 1. |
| PGED2 | I/O | ST | Data I/O pin for Programming/Debugging Communication Channel 2. |
| PGEC2 | I | ST | Clock input pin for Programming/Debugging Communication Channel 2. |
| PGED3 | I/O | ST | Data I/O pin for Programming/Debugging Communication Channel 3. |
| PGEC3 | I | ST | Clock input pin for Programming/Debugging Communication Channel 3. |
| MCLR | I/P | ST | Master Clear (Reset) input. This pin is an active-low Reset to the device. |
| AVDD | P | P | Positive supply for analog modules. |
| AVSS | P | P | Ground reference for analog modules. |
| VDD | P | — | Positive supply for peripheral logic and I/O pins. |
| VCAP | P | — | CPU logic filter capacitor connection. |
| VSS | P | — | Ground reference for logic and I/O pins. |

Legend: CMOS = CMOS compatible input or output Analog = Analog input I = Input
 ST = Schmitt Trigger input with CMOS levels P = Power O = Output
 TTL = Transistor-Transistor Logic

NOTES:

2.0 GUIDELINES FOR GETTING STARTED WITH 16-BIT DIGITAL SIGNAL CONTROLLERS

Note 1: This data sheet summarizes the features of the dsPIC33FJ32GS406/606/608/610 and dsPIC33FJ64GS406/606/608/610 family of devices. It is not intended to be a comprehensive reference source. To complement the information in this data sheet, refer to the “dsPIC33F/PIC24H Family Reference Manual”. Please see the Microchip web site (www.microchip.com) for the latest dsPIC33F/PIC24H Family Reference Manual sections.

2: Some registers and associated bits described in this section may not be available on all devices. Refer to [Section 4.0 “Memory Organization”](#) in this data sheet for device-specific register and bit information.

2.1 Basic Connection Requirements

Getting started with the dsPIC33FJ32GS406/606/608/610 and dsPIC33FJ64GS406/606/608/610 family of 16-bit Digital Signal Controllers (DSC) requires attention to a minimal set of device pin connections before proceeding with development. The following is a list of pin names, which must always be connected:

- All VDD and VSS pins (see [Section 2.2 “Decoupling Capacitors”](#))
- All AVDD and AVSS pins (regardless if ADC module is not used) (see [Section 2.2 “Decoupling Capacitors”](#))
- VCAP (see [Section 2.3 “Capacitor on Internal Voltage Regulator \(VCAP\)”](#))
- MCLR pin (see [Section 2.4 “Master Clear \(MCLR\) Pin”](#))
- PGECx/PGEDx pins used for In-Circuit Serial Programming™ (ICSP™) and debugging purposes (see [Section 2.5 “ICSP Pins”](#))
- OSC1 and OSC2 pins when external oscillator source is used (see [Section 2.6 “External Oscillator Pins”](#))

2.2 Decoupling Capacitors

The use of decoupling capacitors on every pair of power supply pins, such as VDD, VSS, AVDD, and AVSS is required.

Consider the following criteria when using decoupling capacitors:

- **Value and type of capacitor:** Recommendation of 0.1 μF (100 nF), 10-20V. This capacitor should be a low-ESR and have resonance frequency in the range of 20 MHz and higher. It is recommended that ceramic capacitors be used.
- **Placement on the printed circuit board:** The decoupling capacitors should be placed as close to the pins as possible. It is recommended to place the capacitors on the same side of the board as the device. If space is constricted, the capacitor can be placed on another layer on the PCB using a via; however, ensure that the trace length from the pin to the capacitor is within one-quarter inch (6 mm) in length.
- **Handling high-frequency noise:** If the board is experiencing high-frequency noise, upward of tens of MHz, add a second ceramic-type capacitor in parallel to the above described decoupling capacitor. The value of the second capacitor can be in the range of 0.01 μF to 0.001 μF . Place this second capacitor next to the primary decoupling capacitor. In high-speed circuit designs, consider implementing a decade pair of capacitances as close to the power and ground pins as possible. For example, 0.1 μF in parallel with 0.001 μF .
- **Maximizing performance:** On the board layout from the power supply circuit, run the power and return traces to the decoupling capacitors first, and then to the device pins. This ensures that the decoupling capacitors are first in the power chain. Equally important is to keep the trace length between the capacitor and the power pins to a minimum, thereby reducing PCB track inductance.

FIGURE 2-1: RECOMMENDED MINIMUM CONNECTION



2.2.1 TANK CAPACITORS

On boards with power traces running longer than six inches in length, it is suggested to use a tank capacitor for integrated circuits including DSCs to supply a local power source. The value of the tank capacitor should be determined based on the trace resistance that connects the power supply source to the device, and the maximum current drawn by the device in the application. In other words, select the tank capacitor so that it meets the acceptable voltage sag at the device. Typical values range from 4.7 µF to 47 µF.

2.3 Capacitor on Internal Voltage Regulator (VCAP)

A low-ESR (< 0.5 Ohms) capacitor is required on the VCAP pin, which is used to stabilize the voltage regulator output voltage. The VCAP pin must not be connected to VDD, and must have a minimum capacitor 22 µF, 16V connected to ground. The type can be ceramic or tantalum. Refer to [Section 27.0 “Electrical Characteristics”](#) for additional information.

The placement of this capacitor should be close to the VCAP. It is recommended that the trace length not exceed one-quarter inch (6 mm). Refer to [Section 24.2 “On-Chip Voltage Regulator”](#) for details.

2.4 Master Clear (MCLR) Pin

The MCLR pin provides for two specific device functions:

- Device Reset
- Device programming and debugging

During device programming and debugging, the resistance and capacitance that can be added to the pin must be considered. Device programmers and debuggers drive the MCLR pin. Consequently, specific voltage levels (VIH and VIL) and fast signal transitions must not be adversely affected. Therefore, specific values of R and C will need to be adjusted based on the application and PCB requirements.

For example, as shown in [Figure 2-2](#), it is recommended that the capacitor C, be isolated from the MCLR pin during programming and debugging operations.

Place the components shown in [Figure 2-2](#) within one-quarter inch (6 mm) from the MCLR pin.

FIGURE 2-2: EXAMPLE OF MCLR PIN CONNECTIONS^(1,2)



2.5 ICSP Pins

The PGECx and PGEDx pins are used for In-Circuit Serial Programming™ (ICSP™) and debugging purposes. It is recommended to keep the trace length between the ICSP connector and the ICSP pins on the device as short as possible. If the ICSP connector is expected to experience an ESD event, a series resistor is recommended, with the value in the range of a few tens of Ohms, not to exceed 100 Ohms.

Pull-up resistors, series diodes, and capacitors on the PGECx and PGEDx pins are not recommended as they will interfere with the programmer/debugger communications to the device. If such discrete components are an application requirement, they should be removed from the circuit during programming and debugging. Alternatively, refer to the AC/DC characteristics and timing requirements information in the respective device Flash programming specification for information on capacitive loading limits and pin input voltage high (V_{IH}) and input low (V_{IL}) requirements.

Ensure that the “Communication Channel Select” (i.e., PGECx/PGEDx pins) programmed into the device matches the physical connections for the ICSP to MPLAB® ICD 3 or MPLAB REAL ICE™.

For more information on ICD 3 and REAL ICE connection requirements, refer to the following documents that are available on the Microchip web site.

- “Using MPLAB® ICD 3” (poster) (DS51765)
- “MPLAB® ICD 3 Design Advisory” (DS51764)
- “MPLAB® REAL ICE™ In-Circuit Debugger User’s Guide” (DS51616)
- “Using MPLAB® REAL ICE™” (poster) (DS51749)

2.6 External Oscillator Pins

Many DSCs have options for at least two oscillators: a high-frequency primary oscillator and a low-frequency secondary oscillator (refer to [Section 9.0 “Oscillator Configuration”](#) for details).

The oscillator circuit should be placed on the same side of the board as the device. Also, place the oscillator circuit close to the respective oscillator pins, not exceeding one-half inch (12 mm) distance between them. The load capacitors should be placed next to the oscillator itself, on the same side of the board. Use a grounded copper pour around the oscillator circuit to isolate them from surrounding circuits. The grounded copper pour should be routed directly to the MCU ground. Do not run any signal traces or power traces inside the ground pour. Also, if using a two-sided board, avoid any traces on the other side of the board where the crystal is placed. A suggested layout is shown in [Figure 2-3](#).

FIGURE 2-3: SUGGESTED PLACEMENT OF THE OSCILLATOR CIRCUIT



2.7 Oscillator Value Conditions on Device Start-up

If the PLL of the target device is enabled and configured for the device start-up oscillator, the maximum oscillator source frequency must be limited to $4 \text{ MHz} < F_{IN} < 8 \text{ MHz}$ to comply with device PLL start-up conditions. This means that if the external oscillator frequency is outside this range, the application must start-up in the FRC mode first. The default PLL settings after a POR with an oscillator frequency outside this range will violate the device operating speed.

Once the device powers up, the application firmware can initialize the PLL SFRs, CLKDIV, and PLLDBF to a suitable value, and then perform a clock switch to the Oscillator + PLL clock source. Note that clock switching must be enabled in the device Configuration Word.

2.8 Configuration of Analog and Digital Pins During ICSP Operations

If MPLAB ICD 3 or REAL ICE is selected as a debugger, it automatically initializes all of the Analog-to-Digital input pins (ANx) as “digital” pins, by setting all bits in the ADPCFG and ADPCFG2 registers.

The bits in the registers that correspond to the analog-to-digital pins that are initialized by MPLAB ICD 2, ICD 3, or REAL ICE, must not be cleared by the user application firmware; otherwise, communication errors will result between the debugger and the device.

If your application needs to use certain analog-to-digital pins as analog input pins during the debug session, the user application must clear the corresponding bits in the ADPCFG and ADPCFG2 registers during initialization of the ADC module.

When MPLAB ICD 3 or REAL ICE is used as a programmer, the user application firmware must correctly configure the ADPCFG and ADPCFG2 registers. Automatic initialization of these registers is only done during debugger operation. Failure to correctly configure the register(s) will result in all analog-to-digital pins being recognized as analog input pins, resulting in the port value being read as a logic ‘0’, which may affect user application functionality.

2.9 Unused I/Os

Unused I/O pins should be configured as outputs and driven to a logic low state.

Alternatively, connect a 1k to 10k resistor between Vss and unused pins and drive the output to logic low.

2.10 Typical Application Connection Examples

Examples of typical application connections are shown in [Figure 2-4](#) through [Figure 2-11](#).

FIGURE 2-4: DIGITAL PFC



FIGURE 2-5: BOOST CONVERTER IMPLEMENTATION



FIGURE 2-6: SINGLE-PHASE SYNCHRONOUS BUCK CONVERTER

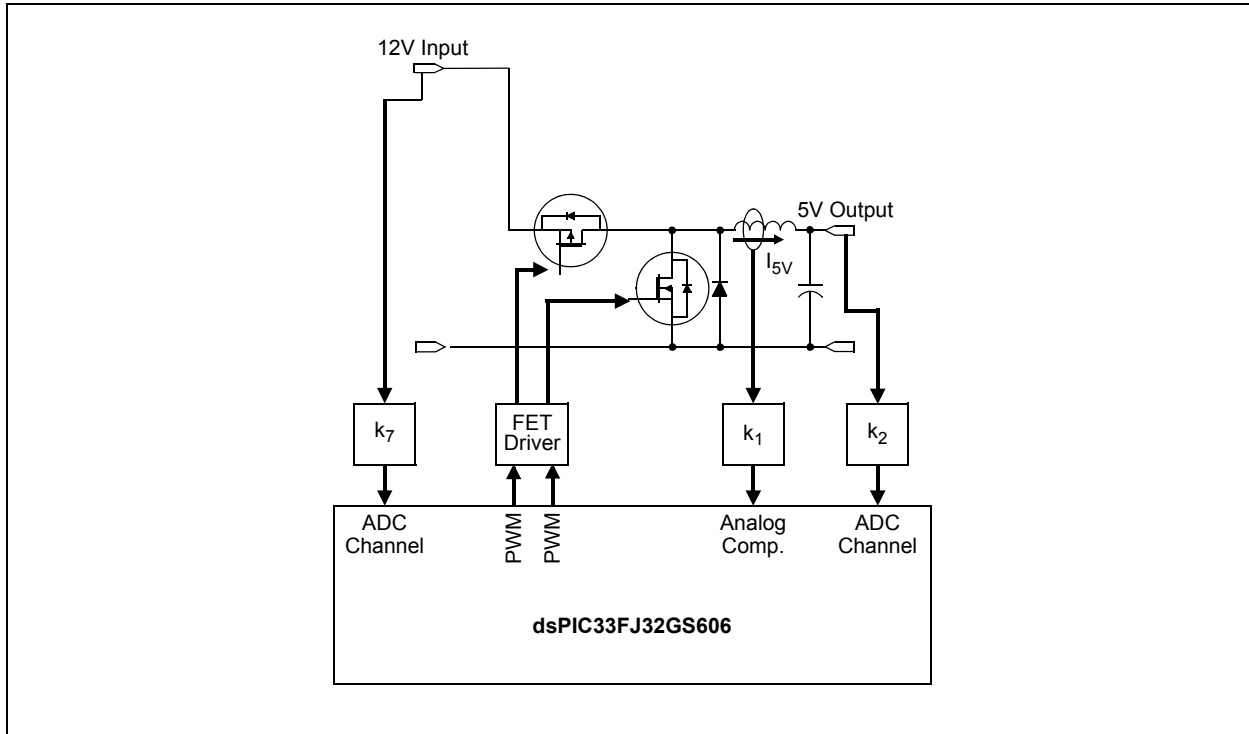

FIGURE 2-7: MULTI-PHASE SYNCHRONOUS BUCK CONVERTER

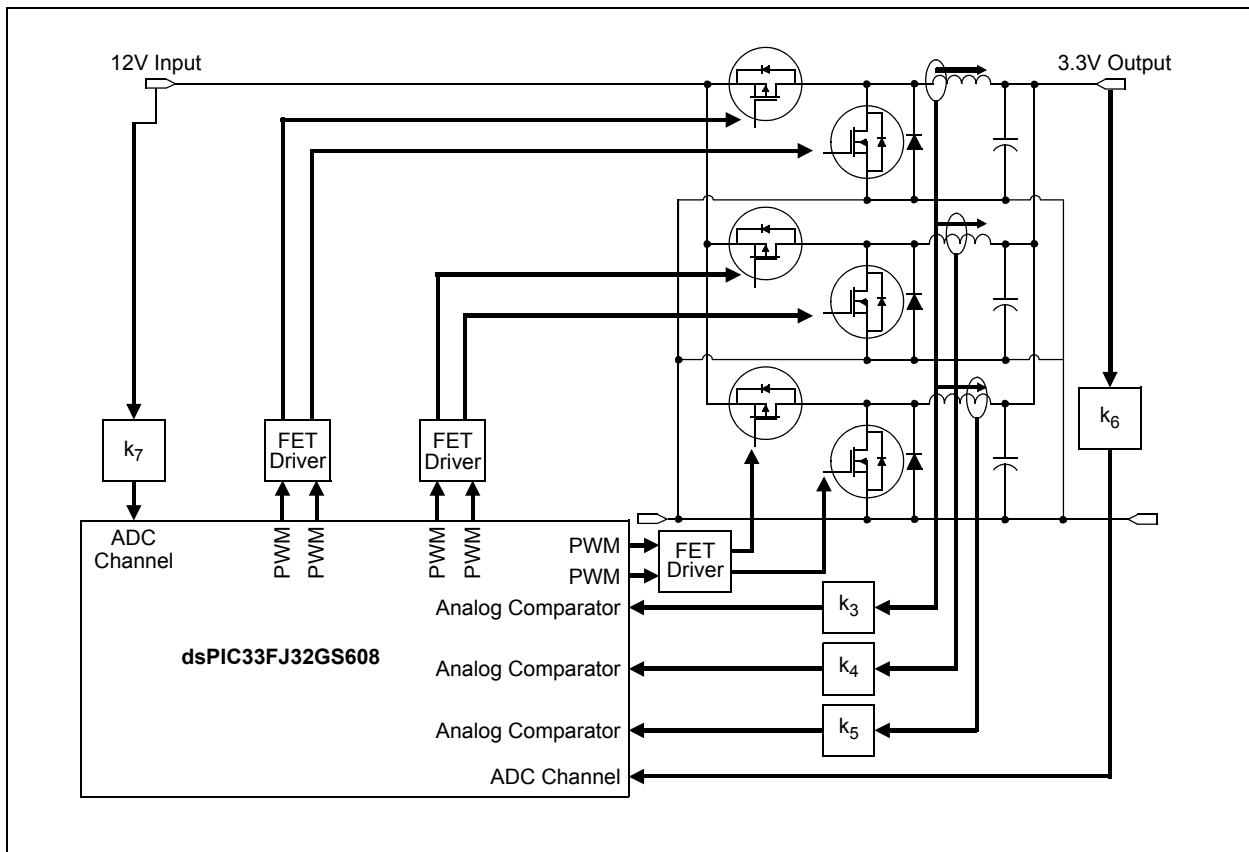

FIGURE 2-8: OFF-LINE UPS



FIGURE 2-9: INTERLEAVED PFC



FIGURE 2-10: PHASE-SHIFTED FULL-BRIDGE CONVERTER



FIGURE 2-11: AC-TO-DC POWER SUPPLY WITH PFC AND THREE OUTPUTS (12V, 5V, AND 3.3V)



3.0 CPU

Note 1: This data sheet summarizes the features of the dsPIC33FJ32GS406/606/608/610 and dsPIC33FJ64GS406/606/608/610 families of devices. It is not intended to be a comprehensive reference source. To complement the information in this data sheet, refer to **Section 2. “CPU”** (DS70204) in the “*dsPIC33F/PIC24H Family Reference Manual*”, which is available from the Microchip web site (www.microchip.com).

2: Some registers and associated bits described in this section may not be available on all devices. Refer to **Section 4.0 “Memory Organization”** in this data sheet for device-specific register and bit information.

The dsPIC33FJ32GS406/606/608/610 and dsPIC33FJ64GS406/606/608/610 CPU module has a 16-bit (data) modified Harvard architecture with an enhanced instruction set, including significant support for DSP. The CPU has a 24-bit instruction word with a variable length opcode field. The Program Counter (PC) is 23 bits wide and addresses up to 4M x 24 bits of user program memory space. The actual amount of program memory implemented varies from device to device. A single-cycle instruction prefetch mechanism is used to help maintain throughput and provides predictable execution. All instructions execute in a single cycle, with the exception of instructions that change the program flow, the double-word move (`MOV.D`) instruction and the table instructions. Overhead-free program loop constructs are supported using the `DO` and `REPEAT` instructions, both of which are interruptible at any point.

The dsPIC33FJ32GS406/606/608/610 and dsPIC33FJ64GS406/606/608/610 devices have sixteen, 16-bit working registers in the programmer's model. Each of the working registers can serve as a data, address or address offset register. The sixteenth working register (W15) operates as a Software Stack Pointer (SP) for interrupts and calls.

There are two classes of instruction in the dsPIC33FJ32GS406/606/608/610 and dsPIC33FJ64GS406/606/608/610 devices: MCU and DSP. These two instruction classes are seamlessly integrated into a single CPU. The instruction set includes many addressing modes and is designed for optimum C compiler efficiency. For most instructions, the dsPIC33FJ32GS406/606/608/610 and dsPIC33FJ64GS406/606/608/610 is capable of executing a data (or program data) memory read, a working register (data) read, a data memory write and a program (instruction) memory read per instruction cycle. As a result, three parameter instructions can be supported, allowing $A + B = C$ operations to be executed in a single cycle.

A block diagram of the CPU is shown in [Figure 3-1](#), and the programmer's model for the dsPIC33FJ32GS406/606/608/610 and dsPIC33FJ64GS406/606/608/610 is shown in [Figure 3-2](#).

3.1 Data Addressing Overview

The data space can be addressed as 32K words or 64 Kbytes and is split into two blocks, referred to as X and Y data memory. Each memory block has its own independent Address Generation Unit (AGU). The MCU class of instructions operates solely through the X memory AGU, which accesses the entire memory map as one linear data space. Certain DSP instructions operate through the X and Y AGUs to support dual operand reads, which splits the data address space into two parts. The X and Y data space boundary is device-specific.

Overhead-free circular buffers (Modulo Addressing mode) are supported in both X and Y address spaces. The Modulo Addressing removes the software boundary checking overhead for DSP algorithms. Furthermore, the X AGU circular addressing can be used with any of the MCU class of instructions. The X AGU also supports Bit-Reversed Addressing to greatly simplify input or output data reordering for radix-2 FFT algorithms.

The upper 32 Kbytes of the data space memory map can optionally be mapped into program space at any 16K program word boundary defined by the 8-bit Program Space Visibility Page (PSVPAG) register. The program-to-data space mapping feature lets any instruction access program space as if it were data space.

3.2 DSP Engine Overview

The DSP engine features a high-speed, 17-bit by 17-bit multiplier, a 40-bit ALU, two 40-bit saturating accumulators and a 40-bit bidirectional barrel shifter. The barrel shifter is capable of shifting a 40-bit value up to 16 bits, right or left, in a single cycle. The DSP instructions operate seamlessly with all other instructions and have been designed for optimal real-time performance. The `MAC` instruction and other associated instructions can concurrently fetch two data operands from memory while multiplying two W registers and accumulating and optionally saturating the result in the same cycle. This instruction functionality requires that the RAM data space be split for these instructions and linear for all others. Data space partitioning is achieved in a transparent and flexible manner through dedicating certain working registers to each address space.

3.3 Special MCU Features

The dsPIC33FJ32GS406/606/608/610 and dsPIC33FJ64GS406/606/608/610 features a 17-bit by 17-bit single-cycle multiplier that is shared by both the MCU ALU and DSP engine. The multiplier can perform signed, unsigned and mixed sign multiplication. Using a 17-bit by 17-bit multiplier for 16-bit by 16-bit multiplication not only allows you to perform mixed sign multiplication, it also achieves accurate results for special operations, such as $(-1.0) \times (-1.0)$.

The dsPIC33FJ32GS406/606/608/610 and dsPIC33FJ64GS406/606/608/610 supports 16/16 and 32/16 divide operations, both fractional and integer. All divide instructions are iterative operations. They must be executed within a REPEAT loop, resulting in a total execution time of 19 instruction cycles. The divide operation can be interrupted during any of those 19 cycles without loss of data.

A 40-bit barrel shifter is used to perform up to a 16-bit left or right shift in a single cycle. The barrel shifter can be used by both MCU and DSP instructions.

FIGURE 3-1: dsPIC33FJ32GS406/606/608/610 and dsPIC33FJ64GS406/606/608/610 CPU CORE BLOCK DIAGRAM

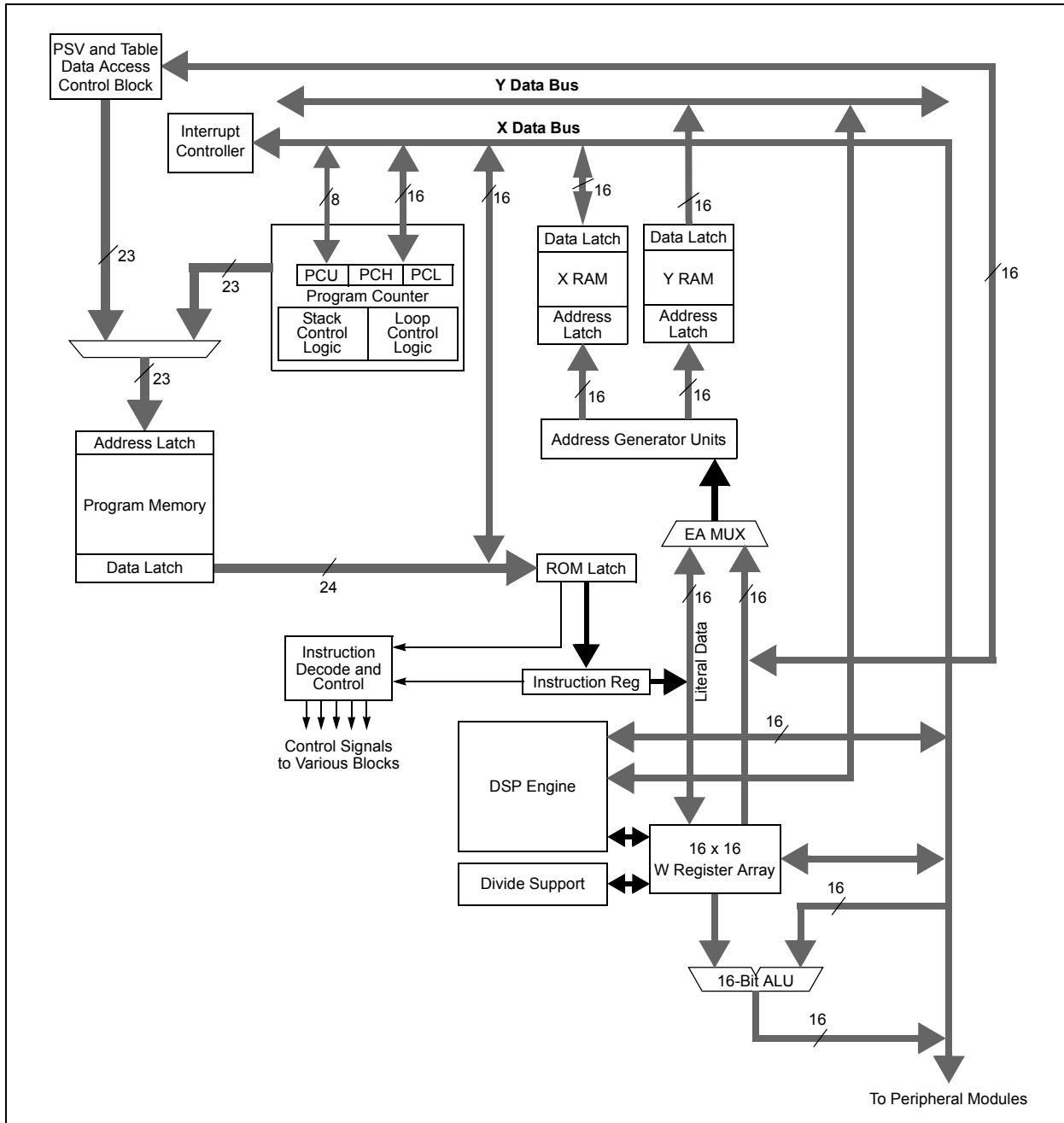

FIGURE 3-2: PROGRAMMER'S MODEL



dsPIC33FJ32GS406/606/608/610 and dsPIC33FJ64GS406/606/608/610

3.4 CPU Control Registers

REGISTER 3-1: SR: CPU STATUS REGISTER

| | | | | | | | |
|--------|-----|-------------------|-------------------|-----|----------------------|-----|-------|
| R-0 | R-0 | R/C-0 | R/C-0 | R-0 | R/C-0 | R-0 | R/W-0 |
| OA | OB | SA ⁽¹⁾ | SB ⁽¹⁾ | OAB | SAB ^(1,4) | DA | DC |
| bit 15 | | | | | | | bit 8 |

| | | | | | | | |
|-------------------------|----------------------|----------------------|-----|-------|-------|-------|-------|
| R/W-0 ⁽³⁾ | R/W-0 ⁽³⁾ | R/W-0 ⁽³⁾ | R-0 | R/W-0 | R/W-0 | R/W-0 | R/W-0 |
| IPL<2:0> ⁽²⁾ | | | RA | N | OV | Z | C |
| bit 7 | | | | | | | bit 0 |

| | | |
|-------------------|-------------------|------------------------------------|
| Legend: | C = Clearable bit | U = Unimplemented bit, read as '0' |
| R = Readable bit | W = Writable bit | '0' = Bit is cleared |
| -n = Value at POR | '1' = Bit is set | x = Bit is unknown |

- bit 15 **OA:** Accumulator A Overflow Status bit
 1 = Accumulator A overflowed
 0 = Accumulator A has not overflowed
- bit 14 **OB:** Accumulator B Overflow Status bit
 1 = Accumulator B overflowed
 0 = Accumulator B has not overflowed
- bit 13 **SA:** Accumulator A Saturation 'Sticky' Status bit⁽¹⁾
 1 = Accumulator A is saturated or has been saturated at some time
 0 = Accumulator A is not saturated
- bit 12 **SB:** Accumulator B Saturation 'Sticky' Status bit⁽¹⁾
 1 = Accumulator B is saturated or has been saturated at some time
 0 = Accumulator B is not saturated
- bit 11 **OAB:** OA || OB Combined Accumulator Overflow Status bit
 1 = Accumulators A or B have overflowed
 0 = Neither Accumulators A or B have overflowed
- bit 10 **SAB:** SA || SB Combined Accumulator 'Sticky' Status bit^(1,4)
 1 = Accumulators A or B are saturated or have been saturated at some time in the past
 0 = Neither Accumulator A or B are saturated
- bit 9 **DA:** DO Loop Active bit
 1 = DO loop in progress
 0 = DO loop not in progress
- bit 8 **DC:** MCU ALU Half Carry/Borrow bit
 1 = A carry-out from the 4th low-order bit (for byte-sized data) or 8th low-order bit (for word-sized data) of the result occurred
 0 = No carry-out from the 4th low-order bit (for byte-sized data) or 8th low-order bit (for word-sized data) of the result occurred

- Note 1:** This bit can be read or cleared (not set).
- Note 2:** The IPL<2:0> bits are concatenated with the IPL<3> bit (CORCON<3>) to form the CPU Interrupt Priority Level (IPL). The value in parentheses indicates the IPL if IPL<3> = 1. User interrupts are disabled when IPL<3> = 1.
- Note 3:** The IPL<2:0> Status bits are read-only when NSTDIS = 1 (INTCON1<15>).
- Note 4:** Clearing this bit will clear SA and SB.

REGISTER 3-1: SR: CPU STATUS REGISTER (CONTINUED)

| | |
|---------|---|
| bit 7-5 | IPL<2:0> : CPU Interrupt Priority Level Status bits ^(2,3) 111 = CPU Interrupt Priority Level is 7 (15), user interrupts disabled 110 = CPU Interrupt Priority Level is 6 (14) 101 = CPU Interrupt Priority Level is 5 (13) 100 = CPU Interrupt Priority Level is 4 (12) 011 = CPU Interrupt Priority Level is 3 (11) 010 = CPU Interrupt Priority Level is 2 (10) 001 = CPU Interrupt Priority Level is 1 (9) 000 = CPU Interrupt Priority Level is 0 (8) |
| bit 4 | RA : REPEAT Loop Active bit 1 = REPEAT loop in progress 0 = REPEAT loop not in progress |
| bit 3 | N : MCU ALU Negative bit 1 = Result was negative 0 = Result was non-negative (zero or positive) |
| bit 2 | OV : MCU ALU Overflow bit This bit is used for signed arithmetic (2's complement). It indicates an overflow of a magnitude that causes the sign bit to change state. 1 = Overflow occurred for signed arithmetic (in this arithmetic operation) 0 = No overflow occurred |
| bit 1 | Z : MCU ALU Zero bit 1 = An operation that affects the Z bit has set it at some time in the past 0 = The most recent operation that affects the Z bit has cleared it (i.e., a non-zero result) |
| bit 0 | C : MCU ALU Carry/Borrow bit 1 = A carry-out from the Most Significant bit of the result occurred 0 = No carry-out from the Most Significant bit of the result occurred |

- Note 1:** This bit can be read or cleared (not set).
- 2:** The IPL<2:0> bits are concatenated with the IPL<3> bit (CORCON<3>) to form the CPU Interrupt Priority Level (IPL). The value in parentheses indicates the IPL if IPL<3> = 1. User interrupts are disabled when IPL<3> = 1.
- 3:** The IPL<2:0> Status bits are read-only when NSTDIS = 1 (INTCON1<15>).
- 4:** Clearing this bit will clear SA and SB.

dsPIC33FJ32GS406/606/608/610 and dsPIC33FJ64GS406/606/608/610

REGISTER 3-2: CORCON: CORE CONTROL REGISTER

| | | | | | | | |
|--------|-----|-----|-------|--------------------|---------|-----|-------|
| U-0 | U-0 | U-0 | R/W-0 | R/W-0 | R-0 | R-0 | R-0 |
| — | — | — | US | EDT ⁽¹⁾ | DL<2:0> | | |
| bit 15 | | | | | | | bit 8 |

| | | | | | | | |
|-------|-------|-------|--------|---------------------|-------|-------|-------|
| R/W-0 | R/W-0 | R/W-1 | R/W-0 | R/C-0 | R/W-0 | R/W-0 | R/W-0 |
| SATA | SATB | SATDW | ACCSAT | IPL3 ⁽²⁾ | PSV | RND | IF |
| bit 7 | | | | | | | bit 0 |

| | | | |
|-------------------|-------------------|------------------------------------|--------------------|
| Legend: | C = Clearable bit | | |
| R = Readable bit | W = Writable bit | U = Unimplemented bit, read as '0' | |
| -n = Value at POR | '1' = Bit is set | '0' = Bit is cleared | x = Bit is unknown |

- bit 15-13 **Unimplemented:** Read as '0'
- bit 12 **US:** DSP Multiply Unsigned/Signed Control bit
 - 1 = DSP engine multiplies are unsigned
 - 0 = DSP engine multiplies are signed
- bit 11 **EDT:** Early DO Loop Termination Control bit⁽¹⁾
 - 1 = Terminate executing DO loop at end of current loop iteration
 - 0 = No effect
- bit 10-8 **DL<2:0>:** DO Loop Nesting Level Status bits
 - 111 = 7 DO loops active
 -
 -
 -
 - 001 = 1 DO loop active
 - 000 = 0 DO loops active
- bit 7 **SATA:** ACCA Saturation Enable bit
 - 1 = Accumulator A saturation enabled
 - 0 = Accumulator A saturation disabled
- bit 6 **SATB:** ACCB Saturation Enable bit
 - 1 = Accumulator B saturation enabled
 - 0 = Accumulator B saturation disabled
- bit 5 **SATDW:** Data Space Write from DSP Engine Saturation Enable bit
 - 1 = Data space write saturation enabled
 - 0 = Data space write saturation disabled
- bit 4 **ACCSAT:** Accumulator Saturation Mode Select bit
 - 1 = 9.31 saturation (super saturation)
 - 0 = 1.31 saturation (normal saturation)
- bit 3 **IPL3:** CPU Interrupt Priority Level Status bit 3⁽²⁾
 - 1 = CPU Interrupt Priority Level is greater than 7
 - 0 = CPU Interrupt Priority Level is 7 or less
- bit 2 **PSV:** Program Space Visibility in Data Space Enable bit
 - 1 = Program space visible in data space
 - 0 = Program space not visible in data space
- bit 1 **RND:** Rounding Mode Select bit
 - 1 = Biased (conventional) rounding enabled
 - 0 = Unbiased (convergent) rounding enabled
- bit 0 **IF:** Integer or Fractional Multiplier Mode Select bit
 - 1 = Integer mode enabled for DSP multiply ops
 - 0 = Fractional mode enabled for DSP multiply ops

- Note 1:** This bit will always read as '0'.
- Note 2:** The IPL3 bit is concatenated with the IPL<2:0> bits (SR<7:5>) to form the CPU Interrupt Priority Level.

3.5 Arithmetic Logic Unit (ALU)

The dsPIC33FJ32GS406/606/608/610 and dsPIC33FJ64GS406/606/608/610 ALU is 16 bits wide and is capable of addition, subtraction, bit shifts and logic operations. Unless otherwise mentioned, arithmetic operations are 2's complement in nature. Depending on the operation, the ALU can affect the values of the Carry (C), Zero (Z), Negative (N), Overflow (OV) and Digit Carry (DC) Status bits in the SR register. The C and DC Status bits operate as Borrow and Digit Borrow bits, respectively, for subtraction operations.

The ALU can perform 8-bit or 16-bit operations, depending on the mode of the instruction that is used. Data for the ALU operation can come from the W register array or data memory, depending on the addressing mode of the instruction. Likewise, output data from the ALU can be written to the W register array or a data memory location.

Refer to the “16-bit MCU and DSC Programmer’s Reference Manual” (DS70157) for information on the SR bits affected by each instruction.

The dsPIC33FJ32GS406/606/608/610 and dsPIC33FJ64GS406/606/608/610 CPU incorporates hardware support for both multiplication and division. This includes a dedicated hardware multiplier and support hardware for 16-bit divisor division.

3.5.1 MULTIPLIER

Using the high-speed, 17-bit x 17-bit multiplier of the DSP engine, the ALU supports unsigned, signed or mixed sign operation in several MCU multiplication modes:

- 16-bit x 16-bit signed
- 16-bit x 16-bit unsigned
- 16-bit signed x 5-bit (literal) unsigned
- 16-bit unsigned x 16-bit unsigned
- 16-bit unsigned x 5-bit (literal) unsigned
- 16-bit unsigned x 16-bit signed
- 8-bit unsigned x 8-bit unsigned

3.5.2 DIVIDER

The divide block supports 32-bit/16-bit and 16-bit/16-bit signed and unsigned integer divide operations with the following data sizes:

- 32-bit signed/16-bit signed divide
- 32-bit unsigned/16-bit unsigned divide
- 16-bit signed/16-bit signed divide
- 16-bit unsigned/16-bit unsigned divide

The quotient for all divide instructions ends up in W0 and the remainder in W1. 16-bit signed and unsigned DIV instructions can specify any W register for both the 16-bit divisor (Wn) and any W register (aligned) pair (W(m+1):Wm) for the 32-bit dividend. The divide algorithm takes one cycle per bit of divisor, so both 32-bit/16-bit and 16-bit/16-bit instructions take the same number of cycles to execute.

3.6 DSP Engine

The DSP engine consists of a high-speed, 17-bit x 17-bit multiplier, a barrel shifter and a 40-bit adder/subtractor (with two target accumulators, round and saturation logic).

The dsPIC33FJ32GS406/606/608/610 and dsPIC33FJ64GS406/606/608/610 is a single-cycle instruction flow architecture; therefore, concurrent operation of the DSP engine with MCU instruction flow is not possible. However, some MCU ALU and DSP engine resources can be used concurrently by the same instruction (for example, ED, EDAC).

The DSP engine can also perform inherent accumulator-to-accumulator operations that require no additional data. These instructions are ADD, SUB and NEG.

The DSP engine has options selected through bits in the CPU Core Control register (CORCON), as listed below:

- Fractional or integer DSP multiply (IF)
- Signed or unsigned DSP multiply (US)
- Conventional or convergent rounding (RND)
- Automatic saturation on/off for ACCA (SATA)
- Automatic saturation on/off for ACCB (SATB)
- Automatic saturation on/off for writes to data memory (SATDW)
- Accumulator Saturation mode selection (ACCSAT)

A block diagram of the DSP engine is shown in Figure 3-3.

TABLE 3-1: DSP INSTRUCTIONS SUMMARY

| Instruction | Algebraic Operation | ACC Write Back |
|-------------|---------------------|----------------|
| CLR | $A = 0$ | Yes |
| ED | $A = (x - y)^2$ | No |
| EDAC | $A = A + (x - y)^2$ | No |
| MAC | $A = A + (x * y)$ | Yes |
| MAC | $A = A + x^2$ | No |
| MOVSAC | No change in A | Yes |
| MPY | $A = x * y$ | No |
| MPY | $A = x^2$ | No |
| MPY.N | $A = -x * y$ | No |
| MSC | $A = A - x * y$ | Yes |

FIGURE 3-3: DSP ENGINE BLOCK DIAGRAM



3.6.1 MULTIPLIER

The 17-bit x 17-bit multiplier is capable of signed or unsigned operation and can multiplex its output using a scaler to support either 1.31 fractional (Q31) or 32-bit integer results. Unsigned operands are zero-extended into the 17th bit of the multiplier input value. Signed operands are sign-extended into the 17th bit of the multiplier input value. The output of the 17-bit x 17-bit multiplier/scaler is a 33-bit value that is sign-extended to 40 bits. Integer data is inherently represented as a signed 2's complement value, where the Most Significant bit (MSb) is defined as a sign bit. The range of an N-bit 2's complement integer is -2^{N-1} to $2^{N-1} - 1$.

- For a 16-bit integer, the data range is -32768 (0x8000) to 32767 (0x7FFF) including 0.
- For a 32-bit integer, the data range is -2,147,483,648 (0x8000 0000) to 2,147,483,647 (0x7FFF FFFF).

When the multiplier is configured for fractional multiplication, the data is represented as a 2's complement fraction, where the MSb is defined as a sign bit and the radix point is implied to lie just after the sign bit (QX format). The range of an N-bit 2's complement fraction with this implied radix point is -1.0 to $(1 - 2^{1-N})$. For a 16-bit fraction, the Q15 data range is -1.0 (0x8000) to 0.999969482 (0x7FFF) including 0 and has a precision of 3.01518×10^{-5} . In Fractional mode, the 16 x 16 multiply operation generates a 1.31 product that has a precision of 4.65661×10^{-10} .

The same multiplier is used to support the MCU multiply instructions, which include integer 16-bit signed, unsigned and mixed sign multiply operations.

The `MUL` instruction can be directed to use byte or word-sized operands. Byte operands will direct a 16-bit result, and word operands will direct a 32-bit result to the specified register(s) in the W array.

3.6.2 DATA ACCUMULATORS AND ADDER/SUBTRACTER

The data accumulator consists of a 40-bit adder/subtractor with automatic sign extension logic. It can select one of two accumulators (A or B) as its pre-accumulation source and post-accumulation destination. For the `ADD` and `LAC` instructions, the data to be accumulated or loaded can be optionally scaled using the barrel shifter prior to accumulation.

3.6.2.1 Adder/Subtractor, Overflow and Saturation

The adder/subtractor is a 40-bit adder with an optional zero input into one side, and either true or complement data into the other input.

- In the case of addition, the Carry/Borrow input is active-high and the other input is true data (not complemented).
- In the case of subtraction, the Carry/Borrow input is active-low and the other input is complemented.

The adder/subtractor generates Overflow Status bits, SA/SB and OA/OB, which are latched and reflected in the STATUS register:

- Overflow from bit 39: this is a catastrophic overflow in which the sign of the accumulator is destroyed.
- Overflow into guard bits, 32 through 39: this is a recoverable overflow. This bit is set whenever all the guard bits are not identical to each other.

The adder has an additional saturation block that controls accumulator data saturation, if selected. It uses the result of the adder, the Overflow Status bits described previously and the `SAT<A:B>` (`CORCON<7:6>`) and `ACCSAT` (`CORCON<4>`) mode control bits to determine when and to what value to saturate.

Six STATUS register bits support saturation and overflow:

- OA: ACCA overflowed into guard bits
- OB: ACCB overflowed into guard bits
- SA: ACCA saturated (bit 31 overflow and saturation)
or
ACCA overflowed into guard bits and saturated (bit 39 overflow and saturation)
- SB: ACCB saturated (bit 31 overflow and saturation)
or
ACCB overflowed into guard bits and saturated (bit 39 overflow and saturation)
- OAB: Logical OR of OA and OB
- SAB: Logical OR of SA and SB

The OA and OB bits are modified each time data passes through the adder/subtractor. When set, they indicate that the most recent operation has overflowed into the accumulator guard bits (bits 32 through 39). The OA and OB bits can also optionally generate an arithmetic warning trap when set and the corresponding Overflow Trap Flag Enable bits (OVATE, OVBTE) in the INTCON1 register are set (refer to [Section 7.0 "Interrupt Controller"](#)). This allows the user application to take immediate action, for example, to correct system gain.

The SA and SB bits are modified each time data passes through the adder/subtractor, but can only be cleared by the user application. When set, they indicate that the accumulator has overflowed its maximum range (bit 31 for 32-bit saturation or bit 39 for 40-bit saturation) and will be saturated (if saturation is enabled). When saturation is not enabled, SA and SB default to bit 39 overflow and thus, indicate that a catastrophic overflow has occurred. If the COVTE bit in the INTCON1 register is set, SA and SB bits will generate an arithmetic warning trap when saturation is disabled.

The Overflow and Saturation Status bits can optionally be viewed in the STATUS Register (SR) as the logical OR of OA and OB (in bit OAB) and the logical OR of SA and SB (in bit SAB). Programmers can check one bit in the STATUS Register to determine if either accumulator has overflowed, or one bit to determine if either accumulator has saturated. This is useful for complex number arithmetic, which typically uses both accumulators.

The device supports three Saturation and Overflow modes:

- **Bit 39 Overflow and Saturation:**
When bit 39 overflow and saturation occurs, the saturation logic loads the maximally positive 9.31 (0x7FFFFFFF) or maximally negative 9.31 value (0x80000000) into the target accumulator. The SA or SB bit is set and remains set until cleared by the user application. This condition is referred to as 'super saturation' and provides protection against erroneous data or unexpected algorithm problems (such as gain calculations).
- **Bit 31 Overflow and Saturation:**
When bit 31 overflow and saturation occurs, the saturation logic then loads the maximally positive 1.31 value (0x007FFFFFFF) or maximally negative 1.31 value (0x00800000) into the target accumulator. The SA or SB bit is set and remains set until cleared by the user application. When this Saturation mode is in effect, the guard bits are not used, so the OA, OB or OAB bits are never set.
- **Bit 39 Catastrophic Overflow:**
The bit 39 Overflow Status bit from the adder is used to set the SA or SB bit, which remains set until cleared by the user application. No saturation operation is performed, and the accumulator is allowed to overflow, destroying its sign. If the COVTE bit in the INTCON1 register is set, a catastrophic overflow can initiate a trap exception.

3.6.3 ACCUMULATOR 'WRITE BACK'

The MAC class of instructions (with the exception of MPY, MPY.N, ED and EDAC) can optionally write a rounded version of the high word (bits 31 through 16) of the accumulator that is not targeted by the instruction into data space memory. The write is performed across the X bus into combined X and Y address space. The following addressing modes are supported:

- **W13, Register Direct:**
The rounded contents of the non-target accumulator are written into W13 as a 1.15 fraction.
- **[W13] + = 2, Register Indirect with Post-Increment:**
The rounded contents of the non-target accumulator are written into the address pointed to by W13 as a 1.15 fraction. W13 is then incremented by 2 (for a word write).

3.6.3.1 Round Logic

The round logic is a combinational block that performs a conventional (biased) or convergent (unbiased) round function during an accumulator write (store). The Round mode is determined by the state of the RND bit in the CORCON register. It generates a 16-bit, 1.15 data value that is passed to the data space write saturation logic. If rounding is not indicated by the instruction, a truncated 1.15 data value is stored and the least significant word is simply discarded.

Conventional rounding zero-extends bit 15 of the accumulator and adds it to the ACCxH word (bits 16 through 31 of the accumulator).

- If the ACCxL word (bits 0 through 15 of the accumulator) is between 0x8000 and 0xFFFF (0x8000 included), ACCxH is incremented.
- If ACCxL is between 0x0000 and 0x7FFF, ACCxH is left unchanged.

A consequence of this algorithm is that over a succession of random rounding operations, the value tends to be biased slightly positive.

Convergent (or unbiased) rounding operates in the same manner as conventional rounding, except when ACCxL equals 0x8000. In this case, the Least Significant bit (bit 16 of the accumulator) of ACCxH is examined:

- If it is '1', ACCxH is incremented.
- If it is '0', ACCxH is not modified.

Assuming that bit 16 is effectively random in nature, this scheme removes any rounding bias that may accumulate.

The SAC and SAC.R instructions store either a truncated (SAC), or rounded (SAC.R) version of the contents of the target accumulator to data memory via the X bus, subject to data saturation (see [Section 3.6.3.2 "Data Space Write Saturation"](#)). For the MAC class of instructions, the accumulator write-back operation functions in the same manner, addressing combined MCU (X and Y) data space through the X bus. For this class of instructions, the data is always subject to rounding.

3.6.3.2 Data Space Write Saturation

In addition to adder/subtractor saturation, writes to data space can also be saturated, but without affecting the contents of the source accumulator. The data space write saturation logic block accepts a 16-bit, 1.15 fractional value from the round logic block as its input, together with overflow status from the original source (accumulator) and the 16-bit round adder. These inputs are combined and used to select the appropriate 1.15 fractional value as output to write to data space memory.

If the SATDW bit in the CORCON register is set, data (after rounding or truncation) is tested for overflow and adjusted accordingly:

- For input data greater than 0x007FFF, data written to memory is forced to the maximum positive 1.15 value, 0x7FFF.
- For input data less than 0xFF8000, data written to memory is forced to the maximum negative 1.15 value, 0x8000.

The Most Significant bit of the source (bit 39) is used to determine the sign of the operand being tested.

If the SATDW bit in the CORCON register is not set, the input data is always passed through unmodified under all conditions.

3.6.4 BARREL SHIFTER

The barrel shifter can perform up to 16-bit arithmetic or logic right shifts, or up to 16-bit left shifts in a single cycle. The source can be either of the two DSP accumulators or the X bus (to support multi-bit shifts of register or memory data).

The shifter requires a signed binary value to determine both the magnitude (number of bits) and direction of the shift operation. A positive value shifts the operand right. A negative value shifts the operand left. A value of '0' does not modify the operand.

The barrel shifter is 40 bits wide, thereby obtaining a 40-bit result for DSP shift operations and a 16-bit result for MCU shift operations. Data from the X bus is presented to the barrel shifter between bit positions 16 and 31 for right shifts, and between bit positions 0 and 16 for left shifts.

NOTES:

4.0 MEMORY ORGANIZATION

Note: This data sheet summarizes the features of the dsPIC33FJ32GS406/606/608/610 and dsPIC33FJ64GS406/606/608/610 families of devices. It is not intended to be a comprehensive reference source. To complement the information in this data sheet, refer to the *dsPIC33F/PIC24H Family Reference Manual*, “Section 4. Program Memory” (DS70203), which is available from the Microchip web site (www.microchip.com).

The dsPIC33FJ32GS406/606/608/610 and dsPIC33FJ64GS406/606/608/610 architecture features separate program and data memory spaces and buses. This architecture also allows the direct access to program memory from the data space during code execution.

4.1 Program Address Space

The program address memory space is 4M instructions. The space is addressable by a 24-bit value derived either from the 23-bit Program Counter (PC) during program execution, or from table operation or data space remapping as described in Section 4.6 “Interfacing Program and Data Memory Spaces”.

User application access to the program memory space is restricted to the lower half of the address range (0x000000 to 0x7FFFFFFF). The exception is the use of TBLRD/TBLWT operations, which use TBLPAG<7> to permit access to the Configuration bits and Device ID sections of the configuration memory space.

The memory maps are shown in Figure 4-1.

FIGURE 4-1: PROGRAM MEMORY MAPS FOR dsPIC33FJ32GS406/606/608/610 and dsPIC33FJ64GS406/606/608/610 DEVICES



dsPIC33FJ32GS406/606/608/610 and dsPIC33FJ64GS406/606/608/610

4.1.1 PROGRAM MEMORY ORGANIZATION

The program memory space is organized in word-addressable blocks. Although it is treated as 24 bits wide, it is more appropriate to think of each address of the program memory as a lower and upper word, with the upper byte of the upper word being unimplemented. The lower word always has an even address, while the upper word has an odd address (see [Figure 4-2](#)).

Program memory addresses are always word-aligned on the lower word, and addresses are incremented or decremented by two during the code execution. This arrangement provides compatibility with data memory space addressing and makes data in the program memory space accessible.

4.1.2 INTERRUPT AND TRAP VECTORS

All dsPIC33FJ32GS406/606/608/610 and dsPIC33FJ64GS406/606/608/610 devices reserve the addresses between 0x00000 and 0x000200 for hard-coded program execution vectors. A hardware Reset vector is provided to redirect code execution from the default value of the PC on device Reset to the actual start of code. A GOTO instruction is programmed by the user application at 0x000000, with the actual address for the start of code at 0x000002.

The dsPIC33FJ32GS406/606/608/610 and dsPIC33FJ64GS406/606/608/610 devices also have two Interrupt Vector Tables (IVT), located from 0x000004 to 0x0000FF and 0x000100 to 0x0001FF. These vector tables allow each of the device interrupt sources to be handled by separate Interrupt Service Routines (ISRs). A more detailed discussion of the Interrupt Vector Tables is provided in [Section 7.1 “Interrupt Vector Table”](#).

FIGURE 4-2: PROGRAM MEMORY ORGANIZATION



4.2 Data Address Space

The CPU has a separate 16-bit-wide data memory space. The data space is accessed using separate Address Generation Units (AGUs) for read and write operations. The data memory maps is shown in [Figure 4-3](#).

All Effective Addresses (EAs) in the data memory space are 16 bits wide and point to bytes within the data space. This arrangement gives a data space address range of 64 Kbytes or 32K words. The lower half of the data memory space (that is, when $EA<15> = 0$) is used for implemented memory addresses, while the upper half ($EA<15> = 1$) is reserved for the Program Space Visibility area (see [Section 4.6.3 “Reading Data from Program Memory Using Program Space Visibility”](#)).

The dsPIC33FJ32GS406/606/608/610 and dsPIC33FJ64GS406/606/608/610 devices implement up to 9 Kbytes of data memory. Should an EA point to a location outside of this area, an all-zero word or byte will be returned.

4.2.1 DATA SPACE WIDTH

The data memory space is organized in byte addressable, 16-bit wide blocks. Data is aligned in data memory and registers as 16-bit words, but all data space EAs resolve to bytes. The Least Significant Bytes (LSBs) of each word have even addresses, while the Most Significant Bytes (MSBs) have odd addresses.

4.2.2 DATA MEMORY ORGANIZATION AND ALIGNMENT

To maintain backward compatibility with PIC® MCU devices and improve data space memory usage efficiency, the instruction set supports both word and byte operations. As a consequence of byte accessibility, all Effective Address calculations are internally scaled to step through word-aligned memory. For example, the core recognizes that Post-Modified Register Indirect Addressing mode [Ws++] that results in a value of $Ws + 1$ for byte operations and $Ws + 2$ for word operations.

Data byte reads will read the complete word that contains the byte, using the LSB of any EA to determine which byte to select. The selected byte is placed onto the LSB of the data path. That is, data memory and registers are organized as two parallel byte-wide entities with shared (word) address decode but separate write lines. Data byte writes only write to the corresponding side of the array or register that matches the byte address.

All word accesses must be aligned to an even address. Misaligned word data fetches are not supported, so care must be taken when mixing byte and word operations, or translating from 8-bit MCU code. If a misaligned read or write is attempted, an address error trap is generated. If the error occurred on a read, the instruction underway is completed. If the error occurred on a write, the instruction is executed but the write does not occur. In either case, a trap is then executed, allowing the system and/or user application to examine the machine state prior to execution of the address Fault.

All byte loads into any W register are loaded into the Least Significant Byte. The Most Significant Byte is not modified.

A Sign-Extend (SE) instruction is provided to allow user applications to translate 8-bit signed data to 16-bit signed values. Alternatively, for 16-bit unsigned data, user applications can clear the MSB of any W register by executing a Zero-Extend (ZE) instruction on the appropriate address.

4.2.3 SFR SPACE

The first 2 Kbytes of the Near Data Space, from 0x0000 to 0x07FF, is primarily occupied by Special Function Registers (SFRs). These are used by the core and peripheral modules for controlling the operation of the device.

SFRs are distributed among the modules that they control, and are generally grouped together by module. Much of the SFR space contains unused addresses; these are read as '0'.

| |
|---|
| Note: The actual set of peripheral features and interrupts varies by the device. Refer to the corresponding device tables and pinout diagrams for device-specific information. |
|---|

4.2.4 NEAR DATA SPACE

The 8-Kbyte area between 0x0000 and 0x1FFF is referred to as the Near Data Space. Locations in this space are directly addressable via a 13-bit absolute address field within all memory direct instructions. Additionally, the whole data space is addressable using MOV instructions, which support Memory Direct Addressing mode with a 16-bit address field, or by using Indirect Addressing mode using a working register as an Address Pointer.

FIGURE 4-3: DATA MEMORY MAP FOR DEVICES WITH 4-KBYTE RAM



FIGURE 4-4: DATA MEMORY MAP FOR DEVICES WITH 8-KBYTE RAM



FIGURE 4-5: DATA MEMORY MAP FOR DEVICES WITH 9-KBYTE RAM



4.2.5 X AND Y DATA SPACES

The core has two data spaces, X and Y. These data spaces can be considered either separate (for some DSP instructions), or as one unified linear address range (for MCU instructions). The data spaces are accessed using two Address Generation Units (AGUs) and separate data paths. This feature allows certain instructions to concurrently fetch two words from RAM, thereby enabling efficient execution of DSP algorithms such as Finite Impulse Response (FIR) filtering and Fast Fourier Transform (FFT).

The X data space is used by all instructions and supports all addressing modes. X data space has separate read and write data buses. The X read data bus is the read data path for all instructions that view data space as combined X and Y address space. It is also the X data prefetch path for the dual operand DSP instructions (MAC class).

The Y data space is used in concert with the X data space by the MAC class of instructions (CLR, ED, EDAC, MAC, MOV SAC, MPY, MPY.N and MSC) to provide two concurrent data read paths.

Both the X and Y data spaces support Modulo Addressing mode for all instructions, subject to addressing mode restrictions. Bit-Reversed Addressing mode is only supported for writes to X data space.

All data memory writes, including in DSP instructions, view data space as combined X and Y address space. The boundary between the X and Y data spaces is device-dependent and is not user-programmable.

All Effective Addresses (EAs) are 16 bits wide and point to bytes within the data space. Therefore, the data space address range is 64 Kbytes, or 32K words, though the implemented memory locations vary by device.

4.2.6 DMA RAM

Some devices contain 1 Kbyte of dual ported DMA RAM, which is located at the end of Y data space. Memory locations that are part of Y data RAM and are in the DMA RAM space are accessible simultaneously by the CPU and the DMA Controller module. DMA RAM is utilized by the DMA Controller to store data to be transferred to various peripherals using DMA, as well as data transferred from various peripherals using DMA. The DMA RAM can be accessed by the DMA Controller without having to steal cycles from the CPU.

When the CPU and the DMA Controller attempt to concurrently write to the same DMA RAM location, the hardware ensures that the CPU is given precedence in accessing the DMA RAM location. Therefore, the DMA RAM provides a reliable means of transferring DMA data without ever having to stall the CPU.

TABLE 4-1: CPU CORE REGISTER MAP

| SFR Name | SFR Addr. | Bit 15 | Bit 14 | Bit 13 | Bit 12 | Bit 11 | Bit 10 | Bit 9 | Bit 8 | Bit 7 | Bit 6 | Bit 5 | Bit 4 | Bit 3 | Bit 2 | Bit 1 | Bit 0 | All Resets | |
|----------|-----------|-----------------------------------|----------|----------|----------|----------|----------|----------|----------|----------|----------|---|------------------------------------|-------|-------|-------|-------|------------|------|
| WREG0 | 0000 | Working Register 0 | | | | | | | | | | | | | | | | 0000 | |
| WREG1 | 0002 | Working Register 1 | | | | | | | | | | | | | | | | 0000 | |
| WREG2 | 0004 | Working Register 2 | | | | | | | | | | | | | | | | 0000 | |
| WREG3 | 0006 | Working Register 3 | | | | | | | | | | | | | | | | 0000 | |
| WREG4 | 0008 | Working Register 4 | | | | | | | | | | | | | | | | 0000 | |
| WREG5 | 000A | Working Register 5 | | | | | | | | | | | | | | | | 0000 | |
| WREG6 | 000C | Working Register 6 | | | | | | | | | | | | | | | | 0000 | |
| WREG7 | 000E | Working Register 7 | | | | | | | | | | | | | | | | 0000 | |
| WREG8 | 0010 | Working Register 8 | | | | | | | | | | | | | | | | 0000 | |
| WREG9 | 0012 | Working Register 9 | | | | | | | | | | | | | | | | 0000 | |
| WREG10 | 0014 | Working Register 10 | | | | | | | | | | | | | | | | 0000 | |
| WREG11 | 0016 | Working Register 11 | | | | | | | | | | | | | | | | 0000 | |
| WREG12 | 0018 | Working Register 12 | | | | | | | | | | | | | | | | 0000 | |
| WREG13 | 001A | Working Register 13 | | | | | | | | | | | | | | | | 0000 | |
| WREG14 | 001C | Working Register 14 | | | | | | | | | | | | | | | | 0000 | |
| WREG15 | 001E | Working Register 15 | | | | | | | | | | | | | | | | 0800 | |
| SPLIM | 0020 | Stack Pointer Limit Register | | | | | | | | | | | | | | | | xxxx | |
| ACCAL | 0022 | ACCAL | | | | | | | | | | | | | | | | xxxx | |
| ACCAH | 0024 | ACCAH | | | | | | | | | | | | | | | | xxxx | |
| ACCAU | 0026 | ACCA<39> | ACCA<39> | ACCA<39> | ACCA<39> | ACCA<39> | ACCA<39> | ACCA<39> | ACCA<39> | ACCA<39> | ACCA<39> | ACCA<39> | ACCAU | | | | | xxxx | |
| ACCBL | 0028 | ACCBL | | | | | | | | | | | | | | | | xxxx | |
| ACCBH | 002A | ACCBH | | | | | | | | | | | | | | | | xxxx | |
| ACCBU | 002C | ACCB<39> | ACCB<39> | ACCB<39> | ACCB<39> | ACCB<39> | ACCB<39> | ACCB<39> | ACCB<39> | ACCB<39> | ACCB<39> | ACCB<39> | ACCBU | | | | | xxxx | |
| PCL | 002E | Program Counter Low Word Register | | | | | | | | | | | | | | | | 0000 | |
| PCH | 0030 | — | — | — | — | — | — | — | — | — | — | — | Program Counter High Byte Register | | | | 0000 | | |
| TBLPAG | 0032 | — | — | — | — | — | — | — | — | — | — | Table Page Address Pointer Register | | | | 0000 | | | |
| PSVPAG | 0034 | — | — | — | — | — | — | — | — | — | — | Program Memory Visibility Page Address Pointer Register | | | | 0000 | | | |
| RCOUNT | 0036 | Repeat Loop Counter Register | | | | | | | | | | | | | | | | xxxx | |
| DCOUNT | 0038 | DCOUNT<15:0> | | | | | | | | | | | | | | | | xxxx | |
| DOSTARTL | 003A | DOSTARTL<15:1> | | | | | | | | | | | | | | | | 0 | xxxx |
| DOSTARTH | 003C | — | — | — | — | — | — | — | — | — | — | DOSTARTH<5:0> | | | | 00xx | | | |
| DOENDL | 003E | DOENDL<15:1> | | | | | | | | | | | | | | | | 0 | xxxx |
| DOENDH | 0040 | — | — | — | — | — | — | — | — | — | — | DOENDH | | | | 00xx | | | |
| SR | 0042 | OA | OB | SA | SB | OAB | SAB | DA | DC | IPL2 | IPL1 | IPL0 | RA | N | OV | Z | C | 0000 | |

Legend: x = unknown value on Reset, — = unimplemented, read as '0'. Reset values are shown in hexadecimal.

TABLE 4-1: CPU CORE REGISTER MAP (CONTINUED)

| SFR Name | SFR Addr. | Bit 15 | Bit 14 | Bit 13 | Bit 12 | Bit 11 | Bit 10 | Bit 9 | Bit 8 | Bit 7 | Bit 6 | Bit 5 | Bit 4 | Bit 3 | Bit 2 | Bit 1 | Bit 0 | All Resets |
|----------|-----------|----------|----------|-------------------------------------|--------|----------|---------|-------|-------|----------|-------|-------|----------|-------|-------|-------|-------|------------|
| CORCON | 0044 | — | — | — | US | EDT | DL<2:0> | | | SATA | SATB | SATDW | ACCSAT | IPL3 | PSV | RND | IF | 0000 |
| MODCON | 0046 | XMODEN | YMODEN | — | — | BWM<3:0> | | | | YWM<3:0> | | | XWM<3:0> | | | 0000 | | |
| XMODSRT | 0048 | XS<15:1> | | | | | | | | | | | | | | | 0 | xxxx |
| XMODEND | 004A | XE<15:1> | | | | | | | | | | | | | | | 1 | xxxx |
| YMODSRT | 004C | YS<15:1> | | | | | | | | | | | | | | | 0 | xxxx |
| YMODEND | 004E | YE<15:1> | | | | | | | | | | | | | | | 1 | xxxx |
| XBREV | 0050 | BREN | XB<14:0> | | | | | | | | | | | | | | | xxxx |
| DISICNT | 0052 | — | — | Disable Interrupts Counter Register | | | | | | | | | | | | | | xxxx |

Legend: x = unknown value on Reset, — = unimplemented, read as '0'. Reset values are shown in hexadecimal.

TABLE 4-2: CHANGE NOTIFICATION REGISTER MAP FOR dsPIC33FJ32GS608/610 AND dsPIC33FJ64GS608/610 DEVICES

| File Name | SFR Addr. | Bit 15 | Bit 14 | Bit 13 | Bit 12 | Bit 11 | Bit 10 | Bit 9 | Bit 8 | Bit 7 | Bit 6 | Bit 5 | Bit 4 | Bit 3 | Bit 2 | Bit 1 | Bit 0 | All Resets |
|-----------|-----------|---------|---------|---------|---------|---------|---------|--------|--------|---------|---------|---------|---------|---------|---------|---------|---------|------------|
| CNEN1 | 0060 | CN15IE | CN14IE | CN13IE | CN12IE | CN11IE | CN10IE | CN9IE | CN8IE | CN7IE | CN6IE | CN5IE | CN4IE | CN3IE | CN2IE | CN1IE | CN0IE | 0000 |
| CNEN2 | 0062 | — | — | — | — | — | — | — | — | CN23IE | CN22IE | CN21IE | CN20IE | CN19IE | CN18IE | CN17IE | CN16IE | 0000 |
| CNPU1 | 0068 | CN15PUE | CN14PUE | CN13PUE | CN12PUE | CN11PUE | CN10PUE | CN9PUE | CN8PUE | CN7PUE | CN6PUE | CN5PUE | CN4PUE | CN3PUE | CN2PUE | CN1PUE | CN0PUE | 0000 |
| CNPU2 | 006A | — | — | — | — | — | — | — | — | CN23PUE | CN22PUE | CN21PUE | CN20PUE | CN19PUE | CN18PUE | CN17PUE | CN16PUE | 0000 |

Legend: x = unknown value on Reset, — = unimplemented, read as '0'. Reset values are shown in hexadecimal.

TABLE 4-3: CHANGE NOTIFICATION REGISTER MAP FOR dsPIC33FJ32GS406/606 AND dsPIC33FJ64GS406/606 DEVICES

| File Name | SFR Addr. | Bit 15 | Bit 14 | Bit 13 | Bit 12 | Bit 11 | Bit 10 | Bit 9 | Bit 8 | Bit 7 | Bit 6 | Bit 5 | Bit 4 | Bit 3 | Bit 2 | Bit 1 | Bit 0 | All Resets |
|-----------|-----------|---------|---------|---------|---------|---------|---------|--------|--------|---------|---------|--------|--------|--------|---------|---------|---------|------------|
| CNEN1 | 0060 | CN15IE | CN14IE | CN13IE | CN12IE | CN11IE | CN10IE | CN9IE | CN8IE | CN7IE | CN6IE | CN5IE | CN4IE | CN3IE | CN2IE | CN1IE | CN0IE | 0000 |
| CNEN2 | 0062 | — | — | — | — | — | — | — | — | CN23IE | CN22IE | — | — | — | CN18IE | CN17IE | CN16IE | 0000 |
| CNPU1 | 0068 | CN15PUE | CN14PUE | CN13PUE | CN12PUE | CN11PUE | CN10PUE | CN9PUE | CN8PUE | CN7PUE | CN6PUE | CN5PUE | CN4PUE | CN3PUE | CN2PUE | CN1PUE | CN0PUE | 0000 |
| CNPU2 | 006A | — | — | — | — | — | — | — | — | CN23PUE | CN22PUE | — | — | — | CN18PUE | CN17PUE | CN16PUE | 0000 |

Legend: x = unknown value on Reset, — = unimplemented, read as '0'. Reset values are shown in hexadecimal.

TABLE 4-4: INTERRUPT CONTROLLER REGISTER MAP FOR dsPIC33FJ64GS610 DEVICES

| File Name | SFR Addr. | Bit 15 | Bit 14 | Bit 13 | Bit 12 | Bit 11 | Bit 10 | Bit 9 | Bit 8 | Bit 7 | Bit 6 | Bit 5 | Bit 4 | Bit 3 | Bit 2 | Bit 1 | Bit 0 | All Resets |
|-----------|-----------|---------|---------|-------------|---------|---------|--------|--------------|--------|----------|---------|--------------|----------|----------|--------------|---------|---------|------------|
| INTCON1 | 0080 | NSTDIS | OVAERR | OVBERR | COVAERR | GOVBERR | OVATE | OVBT | COVTE | SFTACERR | DIV0ERR | DMACERR | MATHERR | ADDRERR | STKERR | OSCFAIL | — | 0000 |
| INTCON2 | 0082 | ALTIVT | DISI | — | — | — | — | — | — | — | — | — | INT4EP | INT3EP | INT2EP | INT1EP | INT0EP | 0000 |
| IFS0 | 0084 | — | DMA1IF | ADIF | U1TXIF | U1RXIF | SPI1IF | SPI1EIF | T3IF | T2IF | OC2IF | IC2IF | DMA0IF | T1IF | OC1IF | IC1IF | INT0IF | 0000 |
| IFS1 | 0086 | U2TXIF | U2RXIF | INT2IF | T5IF | T4IF | OC4IF | OC3IF | DMA2IF | — | — | — | INT1IF | CNIF | AC1IF | MI2C1IF | SI2C1IF | 0000 |
| IFS2 | 0088 | — | — | — | — | — | — | — | — | — | IC4IF | IC3IF | DMA3IF | C1IF | C1RXIF | SPI2IF | SPI2EIF | 0000 |
| IFS3 | 008A | — | — | — | — | — | QE11IF | PSEMIF | — | — | INT4IF | INT3IF | — | — | MI2C2IF | SI2C2IF | — | 0000 |
| IFS4 | 008C | — | — | — | — | QE12IF | — | PSESMIF | — | — | C1TXIF | — | — | — | U2EIF | U1EIF | — | 0000 |
| IFS5 | 008E | PWM2IF | PWM1IF | ADCP12IF | — | — | — | — | — | — | — | — | ADCP11IF | ADCP10IF | ADCP9IF | ADCP8IF | — | 0000 |
| IFS6 | 0090 | ADCP1IF | ADCP0IF | — | — | — | — | AC4IF | AC3IF | AC2IF | PWM9IF | PWM8IF | PWM7IF | PWM6IF | PWM5IF | PWM4IF | PWM3IF | 0000 |
| IFS7 | 0092 | — | — | — | — | — | — | — | — | — | — | ADCP7IF | ADCP6IF | ADCP5IF | ADCP4IF | ADCP3IF | ADCP2IF | 0000 |
| IEC0 | 0094 | — | DMA1IE | ADIE | U1TXIE | U1RXIE | SPI1IE | SPI1EIE | T3IE | T2IE | OC2IE | IC2IE | DMA0IE | T1IE | OC1IE | IC1IE | INT0IE | 0000 |
| IEC1 | 0096 | U2TXIE | U2RXIE | INT2IE | T5IE | T4IE | OC4IE | OC3IE | DMA2IE | — | — | — | INT1IE | CNIE | AC1IE | MI2C1IE | SI2C1IE | 0000 |
| IEC2 | 0098 | — | — | — | — | — | — | — | — | — | IC4IE | IC3IE | DMA3IE | C1IE | C1RXIE | SPI2IE | SPI2EIE | 0000 |
| IEC3 | 009A | — | — | — | — | — | QE11IE | PSEMIE | — | — | INT4IE | INT3IE | — | — | MI2C2IE | SI2C2IE | — | 0000 |
| IEC4 | 009C | — | — | — | — | QE12IE | — | PSESMIE | — | — | C1TXIE | — | — | — | U2EIE | U1EIE | — | 0000 |
| IEC5 | 009E | PWM2IE | PWM1IE | ADCP12IE | — | — | — | — | — | — | — | — | ADCP11IE | ADCP10IE | ADCP9IE | ADCP8IE | — | 0000 |
| IEC6 | 00A0 | ADCP1IE | ADCP0IE | — | — | — | — | AC4IE | AC3IE | AC2IE | PWM9IE | PWM8IE | PWM7IE | PWM6IE | PWM5IE | PWM4IE | PWM3IE | 0000 |
| IEC7 | 00A2 | — | — | — | — | — | — | — | — | — | — | ADCP7IE | ADCP6IE | ADCP5IE | ADCP4IE | ADCP3IE | ADCP2IE | 0000 |
| IPC0 | 00A4 | — | — | T1IP<2:0> | | — | — | OC1IP<2:0> | | — | — | IC1IP<2:0> | | — | INT0IP<2:0> | | 4444 | |
| IPC1 | 00A6 | — | — | T2IP<2:0> | | — | — | OC2IP<2:0> | | — | — | IC2IP<2:0> | | — | DMA0IP<2:0> | | 4444 | |
| IPC2 | 00A8 | — | — | U1RXIP<2:0> | | — | — | SPI1IP<2:0> | | — | — | SPI1EIP<2:0> | | — | T3IP<2:0> | | 0444 | |
| IPC3 | 00AA | — | — | — | — | — | — | DMA1IP<2:0> | | — | — | ADIP<2:0> | | — | U1TXIP<2:0> | | 0044 | |
| IPC4 | 00AC | — | — | CNIP<2:0> | | — | — | AC1IP<2:0> | | — | — | MI2C1IP<2:0> | | — | SI2C1IP<2:0> | | 4444 | |
| IPC5 | 00AE | — | — | — | — | — | — | — | — | — | — | — | — | — | INT1IP<2:0> | | 0004 | |
| IPC6 | 00B0 | — | — | T4IP<2:0> | | — | — | OC4IP<2:0> | | — | — | OC3IP<2:0> | | — | DMA2IP<2:0> | | 4444 | |
| IPC7 | 00B2 | — | — | U2TXIP<2:0> | | — | — | U2RXIP<2:0> | | — | — | INT2IP<2:0> | | — | T5IP<2:0> | | 4444 | |
| IPC8 | 00B4 | — | — | C1IP<2:0> | | — | — | C1RXIP<2:0> | | — | — | SPI2IP<2:0> | | — | SPI2EIP<2:0> | | 4444 | |
| IPC9 | 00B6 | — | — | — | — | — | — | IC4IP<2:0> | | — | — | IC3IP<2:0> | | — | DMA3IP<2:0> | | 0444 | |
| IPC12 | 00BC | — | — | — | — | — | — | MI2C2IP<2:0> | | — | — | SI2C2IP<2:0> | | — | — | — | — | 0440 |
| IPC13 | 00BE | — | — | — | — | — | — | INT4IP<2:0> | | — | — | INT3IP<2:0> | | — | — | — | — | 0440 |

Legend: x = unknown value on Reset, — = unimplemented, read as '0'. Reset values are shown in hexadecimal.

TABLE 4-4: INTERRUPT CONTROLLER REGISTER MAP FOR dsPIC33FJ64GS610 DEVICES (CONTINUED)

| File Name | SFR Addr. | Bit 15 | Bit 14 | Bit 13 | Bit 12 | Bit 11 | Bit 10 | Bit 9 | Bit 8 | Bit 7 | Bit 6 | Bit 5 | Bit 4 | Bit 3 | Bit 2 | Bit 1 | Bit 0 | All Resets |
|-----------|-----------|--------|---------------|--------|--------|----------|--------------|-------|-------|-------------|---------------|-------|-------|-------|---------------|-------|-------|------------|
| IPC14 | 00C0 | — | — | — | — | — | QEI1IP<2:0> | | | — | PSEMIP<2:0> | | | — | — | — | — | 0440 |
| IPC16 | 00C4 | — | — | — | — | — | U2EIP<2:0> | | | — | U1EIP<2:0> | | | — | — | — | — | 0440 |
| IPC17 | 00C6 | — | — | — | — | — | C1TXIP<2:0> | | | — | — | — | — | — | — | — | — | 0400 |
| IPC18 | 00C8 | — | QEI2IP<2:0> | | | — | — | — | — | — | PSESMIP<2:0> | | | — | — | — | — | 4040 |
| IPC20 | 00CC | — | ADCP10IP<2:0> | | | — | ADCP9IP<2:0> | | | — | ADCP8IP<2:0> | | | — | — | — | — | 4440 |
| IPC21 | 00CE | — | — | — | — | — | — | — | — | — | ADCP12IP<2:0> | | | — | ADCP11IP<2:0> | | | 0044 |
| IPC23 | 00D2 | — | PWM2IP<2:0> | | | — | PWM1IP<2:0> | | | — | — | — | — | — | — | — | — | 4400 |
| IPC24 | 00D4 | — | PWM6IP<2:0> | | | — | PWM5IP<2:0> | | | — | PWM4IP<2:0> | | | — | PWM3IP<2:0> | | | 4444 |
| IPC25 | 00D6 | — | AC2IP<2:0> | | | — | PWM9IP<2:0> | | | — | PWM8IP<2:0> | | | — | PWM7IP<2:0> | | | 4444 |
| IPC26 | 00D8 | — | — | — | — | — | — | — | — | — | AC4IP<2:0> | | | — | AC3IP<2:0> | | | 0044 |
| IPC27 | 00DA | — | ADCP11IP<2:0> | | | — | ADCP0IP<2:0> | | | — | — | — | — | — | — | — | — | 4400 |
| IPC28 | 00DC | — | ADCP5IP<2:0> | | | — | ADCP4IP<2:0> | | | — | ADCP3IP<2:0> | | | — | ADCP2IP<2:0> | | | 4444 |
| IPC29 | 00DE | — | — | — | — | — | — | — | — | — | ADCP7IP<2:0> | | | — | ADCP6IP<2:0> | | | 0044 |
| INTTREG | 00E0 | — | — | — | — | ILR<3:0> | | | — | VECNUM<6:0> | | | | | | 0000 | | |

Legend: x = unknown value on Reset, — = unimplemented, read as '0'. Reset values are shown in hexadecimal.

TABLE 4-5: INTERRUPT CONTROLLER REGISTER MAP FOR dsPIC33FJ64GS608 DEVICES

| SFR Name | SFR Addr. | Bit 15 | Bit 14 | Bit 13 | Bit 12 | Bit 11 | Bit 10 | Bit 9 | Bit 8 | Bit 7 | Bit 6 | Bit 5 | Bit 4 | Bit 3 | Bit 2 | Bit 1 | Bit 0 | All Resets |
|----------|-----------|---------|-------------|----------|---------|---------|--------------|---------|--------|----------|--------------|---------|---------|---------|--------------|-------------|---------|------------|
| INTCON1 | 0080 | NSTDIS | OVAERR | OVBERR | COVAERR | COVBERR | OVATE | OVBTE | COVTE | SFTACERR | DIV0ERR | DMACERR | MATHERR | ADDRERR | STKERR | OSCFAIL | — | 0000 |
| INTCON2 | 0082 | ALTVT | DISI | — | — | — | — | — | — | — | — | — | INT4EP | INT3EP | INT2EP | INT1EP | INT0EP | 0000 |
| IFS0 | 0084 | — | DMA1IF | ADIF | U1TXIF | U1RXIF | SPI1IF | SPI1EIF | T3IF | T2IF | OC2IF | IC2IF | DMA0IF | T1IF | OC1IF | IC1IF | INT0IF | 0000 |
| IFS1 | 0086 | U2TXIF | U2RXIF | INT2IF | T5IF | T4IF | OC4IF | OC3IF | DMA2IF | — | — | — | INT1IF | CNIF | AC1IF | MI2C1IF | SI2C1IF | 0000 |
| IFS2 | 0088 | — | — | — | — | — | — | — | — | — | IC4IF | IC3IF | DMA3IF | C1IF | C1RXIF | SPI2IF | SPI2EIF | 0000 |
| IFS3 | 008A | — | — | — | — | — | QE11IF | PSEMIF | — | — | INT4IF | INT3IF | — | — | MI2C2IF | SI2C2IF | — | 0000 |
| IFS4 | 008C | — | — | — | — | QE12IF | — | PSESMIF | — | — | C1TXIF | — | — | — | U2EIF | U1EIF | — | 0000 |
| IFS5 | 008E | PWM2IF | PWM1IF | ADCP12IF | — | — | — | — | — | — | — | — | — | — | — | ADCP8IF | — | 0000 |
| IFS6 | 0090 | ADCP1IF | ADCP0IF | — | — | — | — | AC4IF | AC3IF | AC2IF | — | PWM8IF | PWM7IF | PWM6IF | PWM5IF | PWM4IF | PWM3IF | 0000 |
| IFS7 | 0092 | — | — | — | — | — | — | — | — | — | — | ADCP7IF | ADCP6IF | ADCP5IF | ADCP4IF | ADCP3IF | ADCP2IF | 0000 |
| IEC0 | 0094 | — | DMA1IE | ADIE | U1TXIE | U1RXIE | SPI1IE | SPI1EIE | T3IE | T2IE | OC2IE | IC2IE | DMA0IE | T1IE | OC1IE | IC1IE | INT0IE | 0000 |
| IEC1 | 0096 | U2TXIE | U2RXIE | INT2IE | T5IE | T4IE | OC4IE | OC3IE | DMA2IE | — | — | — | INT1IE | CNIE | AC1IE | MI2C1IE | SI2C1IE | 0000 |
| IEC2 | 0098 | — | — | — | — | — | — | — | — | — | IC4IE | IC3IE | DMA3IE | C1IE | C1RXIE | SPI2IE | SPI2EIE | 0000 |
| IEC3 | 009A | — | — | — | — | — | QE11IE | PSEMIE | — | — | INT4IE | INT3IE | — | — | MI2C2IE | SI2C2IE | — | 0000 |
| IEC4 | 009C | — | — | — | — | QE12IE | — | PSESMIE | — | — | C1TXIE | — | — | — | U2EIE | U1EIE | — | 0000 |
| IEC5 | 009E | PWM2IE | PWM1IE | ADCP12IE | — | — | — | — | — | — | — | — | — | — | — | ADCP8IE | — | 0000 |
| IEC6 | 00A0 | ADCP1IE | ADCP0IE | — | — | — | — | AC4IE | AC3IE | AC2IE | — | PWM8IE | PWM7IE | PWM6IE | PWM5IE | PWM4IE | PWM3IE | 0000 |
| IEC7 | 00A2 | — | — | — | — | — | — | — | — | — | — | ADCP7IE | ADCP6IE | ADCP5IE | ADCP4IE | ADCP3IE | ADCP2IE | 0000 |
| IPC0 | 00A4 | — | T1IP<2:0> | | | — | OC1IP<2:0> | | | — | IC1IP<2:0> | | | — | INT0IP<2:0> | | | 4444 |
| IPC1 | 00A6 | — | T2IP<2:0> | | | — | OC2IP<2:0> | | | — | IC2IP<2:0> | | | — | DMA0IP<2:0> | | | 4444 |
| IPC2 | 00A8 | — | U1RXIP<2:0> | | | — | SPI1IP<2:0> | | | — | SPI1EIP<2:0> | | | — | T3IP<2:0> | | | 4444 |
| IPC3 | 00AA | — | — | — | — | — | DMA1IP<2:0> | | | — | ADIP<2:0> | | | — | U1TXIP<2:0> | | | 4444 |
| IPC4 | 00AC | — | CNIP<2:0> | | | — | AC1IP<2:0> | | | — | MI2C1IP<2:0> | | | — | SI2C1IP<2:0> | | | 4444 |
| IPC5 | 00AE | — | — | — | — | — | — | — | — | — | — | — | — | — | — | INT1IP<2:0> | | 0004 |
| IPC6 | 00B0 | — | T4IP<2:0> | | | — | OC4IP<2:0> | | | — | OC3IP<2:0> | | | — | DMA2IP<2:0> | | | 4444 |
| IPC7 | 00B2 | — | U2TXIP<2:0> | | | — | U2RXIP<2:0> | | | — | INT2IP<2:0> | | | — | T5IP<2:0> | | | 4444 |
| IPC8 | 00B4 | — | C1IP<2:0> | | | — | C1RXIP<2:0> | | | — | SPI2IP<2:0> | | | — | SPI2EIP<2:0> | | | 4444 |
| IPC9 | 00B6 | — | — | — | — | — | IC4IP<2:0> | | | — | IC3IP<2:0> | | | — | DMA3IP<2:0> | | | 0444 |
| IPC12 | 00BC | — | — | — | — | — | MI2C2IP<2:0> | | | — | SI2C2IP<2:0> | | | — | — | — | — | 0440 |
| IPC13 | 00BE | — | — | — | — | — | INT4IP<2:0> | | | — | INT3IP<2:0> | | | — | — | — | — | 0440 |
| IPC14 | 00C0 | — | — | — | — | — | QE11IP<2:0> | | | — | PSEMIP<2:0> | | | — | — | — | — | 0440 |
| IPC16 | 00C4 | — | — | — | — | — | U2EIP<2:0> | | | — | U1EIP<2:0> | | | — | — | — | — | 0440 |
| IPC17 | 00C6 | — | — | — | — | — | C1TXIP<2:0> | | | — | — | — | — | — | — | — | — | 0400 |
| IPC18 | 00C8 | — | QE12IP<2:0> | | | — | — | — | — | — | PSESMIP<2:0> | | | — | — | — | — | 4040 |

Legend: × = unknown value on Reset, — = unimplemented, read as '0'. Reset values are shown in hexadecimal.

TABLE 4-5: INTERRUPT CONTROLLER REGISTER MAP FOR dsPIC33FJ64GS608 DEVICES (CONTINUED)

| SFR Name | SFR Addr. | Bit 15 | Bit 14 | Bit 13 | Bit 12 | Bit 11 | Bit 10 | Bit 9 | Bit 8 | Bit 7 | Bit 6 | Bit 5 | Bit 4 | Bit 3 | Bit 2 | Bit 1 | Bit 0 | All Resets | |
|----------|-----------|--------|--------------|--------|--------|----------|--------------|-------|-------|-------------|--------------|-------|-------|-------|--------------|-------|-------|------------|------|
| IPC20 | 00CC | — | — | — | — | — | — | — | — | — | ADCP8IP<2:0> | | | — | — | — | — | 0040 | |
| IPC21 | 00CE | — | — | — | — | — | — | — | — | — | ADCP12IP | | | — | — | — | — | 0040 | |
| IPC23 | 00D2 | — | PWM2IP<2:0> | | | — | PWM1IP<2:0> | | | — | — | — | — | — | — | — | — | — | 4400 |
| IPC24 | 00D4 | — | PWM6IP<2:0> | | | — | PWM5IP<2:0> | | | — | PWM4IP<2:0> | | | — | PWM3IP<2:0> | | | 4444 | |
| IPC25 | 00D6 | — | AC2IP<2:0> | | | — | — | — | — | — | PWM8IP<2:0> | | | — | PWM7IP<2:0> | | | 4044 | |
| IPC26 | 00D8 | — | — | — | — | — | — | — | — | — | AC4IP<2:0> | | | — | AC3IP<2:0> | | | 0044 | |
| IPC27 | 00DA | — | ADCP1IP<2:0> | | | — | ADCP0IP<2:0> | | | — | — | — | — | — | — | — | — | — | 4400 |
| IPC28 | 00DC | — | ADCP5IP<2:0> | | | — | ADCP4IP<2:0> | | | — | ADCP3IP<2:0> | | | — | ADCP2IP<2:0> | | | 4444 | |
| IPC29 | 00DE | — | — | — | — | — | — | — | — | — | ADCP7IP<2:0> | | | — | ADCP6IP<2:0> | | | 0044 | |
| INTTREG | 00E0 | — | — | — | — | ILR<3:0> | | | — | VECNUM<6:0> | | | | | | 0000 | | | |

Legend: x = unknown value on Reset, — = unimplemented, read as '0'. Reset values are shown in hexadecimal.

TABLE 4-6: INTERRUPT CONTROLLER REGISTER MAP FOR dsPIC33FJ64GS606 DEVICES

| SFR Name | SFR Addr. | Bit 15 | Bit 14 | Bit 13 | Bit 12 | Bit 11 | Bit 10 | Bit 9 | Bit 8 | Bit 7 | Bit 6 | Bit 5 | Bit 4 | Bit 3 | Bit 2 | Bit 1 | Bit 0 | All Resets |
|----------|-----------|---------|-------------|----------|---------|---------|--------------|---------|--------|----------|--------------|---------|---------|---------|--------------|---------|---------|------------|
| INTCON1 | 0080 | NSTDIS | OVAERR | OVBERR | COVAERR | COVBERR | OVATE | OVBTE | COVTE | SFTACERR | DIV0ERR | DMACERR | MATHERR | ADDRERR | STKERR | OSCFAIL | — | 0000 |
| INTCON2 | 0082 | ALTIPT | DISI | — | — | — | — | — | — | — | — | — | INT4EP | INT3EP | INT2EP | INT1EP | INT0EP | 0000 |
| IFS0 | 0084 | — | DMA1IF | ADIF | U1TXIF | U1RXIF | SPI1IF | SPI1EIF | T3IF | T2IF | OC2IF | IC2IF | DMA0IF | T1IF | OC1IF | IC1IF | INT0IF | 0000 |
| IFS1 | 0086 | U2TXIF | U2RXIF | INT2IF | T5IF | T4IF | OC4IF | OC3IF | DMA2IF | — | — | — | INT1IF | CNIF | AC1IF | MI2C1IF | SI2C1IF | 0000 |
| IFS2 | 0088 | — | — | — | — | — | — | — | — | — | IC4IF | IC3IF | DMA3IF | C1IF | C1RXIF | SPI2IF | SPI2EIF | 0000 |
| IFS3 | 008A | — | — | — | — | — | QE11IF | PSEMIF | — | — | INT4IF | INT3IF | — | — | MI2C2IF | SI2C2IF | — | 0000 |
| IFS4 | 008C | — | — | — | — | QE12IF | — | PSESMIF | — | — | C1TXIF | — | — | — | U2EIF | U1EIF | — | 0000 |
| IFS5 | 008E | PWM2IF | PWM1IF | ADCP12IF | — | — | — | — | — | — | — | — | — | — | — | — | — | 0000 |
| IFS6 | 0090 | ADCP1IF | ADCP0IF | — | — | — | — | AC4IF | AC3IF | AC2IF | PWM9IF | PWM8IF | PWM7IF | PWM6IF | PWM5IF | PWM4IF | PWM3IF | 0000 |
| IFS7 | 0092 | — | — | — | — | — | — | — | — | — | — | ADCP7IF | ADCP6IF | ADCP5IF | ADCP4IF | ADCP3IF | ADCP2IF | 0000 |
| IEC0 | 0094 | — | DMA1IE | ADIE | U1TXIE | U1RXIE | SPI1IE | SPI1EIE | T3IE | T2IE | OC2IE | IC2IE | DMA0IE | T1IE | OC1IE | IC1IE | INT0IE | 0000 |
| IEC1 | 0096 | U2TXIE | U2RXIE | INT2IE | T5IE | T4IE | OC4IE | OC3IE | DMA2IE | — | — | — | INT1IE | CNIE | AC1IE | MI2C1IE | SI2C1IE | 0000 |
| IEC2 | 0098 | — | — | — | — | — | — | — | — | — | IC4IE | IC3IE | DMA3IE | C1IE | C1RXIE | SPI2IE | SPI2EIE | 0000 |
| IEC3 | 009A | — | — | — | — | — | QE11IE | PSEMIE | — | — | INT4IE | INT3IE | — | — | MI2C2IE | SI2C2IE | — | 0000 |
| IEC4 | 009C | — | — | — | — | QE12IE | — | PSESMIE | — | — | C1TXIE | — | — | — | U2EIE | U1EIE | — | 0000 |
| IEC5 | 009E | PWM2IE | PWM1IE | ADCP12IE | — | — | — | — | — | — | — | — | — | — | — | — | — | 0000 |
| IEC6 | 00A0 | ADCP1IE | ADCP0IE | — | — | — | — | AC4IE | AC3IE | AC2IE | — | — | — | PWM6IE | PWM5IE | PWM4IE | PWM3IE | 0000 |
| IEC7 | 00A2 | — | — | — | — | — | — | — | — | — | — | ADCP7IE | ADCP6IE | ADCP5IE | ADCP4IE | ADCP3IE | ADCP2IE | 0000 |
| IPC0 | 00A4 | — | T1IP<2:0> | | | — | OC1IP<2:0> | | | — | IC1IP<2:0> | | | — | INT0IP<2:0> | | | 4444 |
| IPC1 | 00A6 | — | T2IP<2:0> | | | — | OC2IP<2:0> | | | — | IC2IP<2:0> | | | — | DMA0IP<2:0> | | | 4444 |
| IPC2 | 00A8 | — | U1RXIP<2:0> | | | — | SPI1IP<2:0> | | | — | SPI1EIP<2:0> | | | — | T3IP<2:0> | | | 4444 |
| IPC3 | 00AA | — | — | — | — | — | DMA1IP<2:0> | | | — | ADIP<2:0> | | | — | U1TXIP<2:0> | | | 4444 |
| IPC4 | 00AC | — | CNIP<2:0> | | | — | AC1IP<2:0> | | | — | MI2C1IP<2:0> | | | — | SI2C1IP<2:0> | | | 4444 |
| IPC5 | 00AE | — | — | — | — | — | — | — | — | — | — | — | — | — | INT1IP<2:0> | | | 0004 |
| IPC6 | 00B0 | — | T4IP<2:0> | | | — | OC4IP<2:0> | | | — | OC3IP<2:0> | | | — | DMA2IP<2:0> | | | 4444 |
| IPC7 | 00B2 | — | U2TXIP<2:0> | | | — | U2RXIP<2:0> | | | — | INT2IP<2:0> | | | — | T5IP<2:0> | | | 4444 |
| IPC8 | 00B4 | — | C1IP<2:0> | | | — | C1RXIP<2:0> | | | — | SPI2IP<2:0> | | | — | SPI2EIP<2:0> | | | 4444 |
| IPC9 | 00B6 | — | — | — | — | — | IC4IP<2:0> | | | — | IC3IP<2:0> | | | — | DMA3IP<2:0> | | | 0444 |
| IPC12 | 00BC | — | — | — | — | — | MI2C2IP<2:0> | | | — | SI2C2IP<2:0> | | | — | — | — | — | 0440 |
| IPC13 | 00BE | — | — | — | — | — | INT4IP<2:0> | | | — | INT3IP<2:0> | | | — | — | — | — | 0440 |
| IPC14 | 00C0 | — | — | — | — | — | QE11IP<2:0> | | | — | PSEMIP<2:0> | | | — | — | — | — | 0440 |
| IPC16 | 00C4 | — | — | — | — | — | U2EIP<2:0> | | | — | U1EIP<2:0> | | | — | — | — | — | 0440 |
| IPC17 | 00C6 | — | — | — | — | — | C1TXIP<2:0> | | | — | — | — | — | — | — | — | — | 0400 |
| IPC18 | 00C8 | — | QE12IP<2:0> | | | — | — | — | — | — | PSESMIP<2:0> | | | — | — | — | — | 4040 |

Legend: × = unknown value on Reset, — = unimplemented, read as '0'. Reset values are shown in hexadecimal.

TABLE 4-6: INTERRUPT CONTROLLER REGISTER MAP FOR dsPIC33FJ64GS606 DEVICES (CONTINUED)

| SFR Name | SFR Addr. | Bit 15 | Bit 14 | Bit 13 | Bit 12 | Bit 11 | Bit 10 | Bit 9 | Bit 8 | Bit 7 | Bit 6 | Bit 5 | Bit 4 | Bit 3 | Bit 2 | Bit 1 | Bit 0 | All Resets | |
|----------|-----------|--------|--------------|--------|--------|----------|--------------|-------|-------|-------|---------------|-------|-------|-------|--------------|-------|-------|------------|------|
| IPC21 | 00CE | — | — | — | — | — | — | — | — | — | ADCP12IP<2:0> | | | — | — | — | — | 0040 | |
| IPC23 | 00D2 | — | PWM2IP<2:0> | | | — | PWM1IP<2:0> | | | — | — | — | — | — | — | — | — | — | 4400 |
| IPC24 | 00D4 | — | PWM6IP<2:0> | | | — | PWM5IP<2:0> | | | — | PWM4IP<2:0> | | | — | PWM3IP<2:0> | | | 4444 | |
| IPC25 | 00D6 | — | AC2IP<2:0> | | | — | PWM9IP<2:0> | | | — | PWM8IP<2:0> | | | — | PWM7IP<2:0> | | | 4000 | |
| IPC26 | 00D8 | — | — | — | — | — | — | — | — | — | AC4IP<2:0> | | | — | AC3IP<2:0> | | | 0044 | |
| IPC27 | 00DA | — | ADCP1IP<2:0> | | | — | ADCP0IP<2:0> | | | — | — | — | — | — | — | — | — | — | 4400 |
| IPC28 | 00DC | — | ADCP5IP<2:0> | | | — | ADCP4IP<2:0> | | | — | ADCP3IP<2:0> | | | — | ADCP2IP<2:0> | | | 4444 | |
| IPC29 | 00DE | — | — | — | — | — | — | — | — | — | ADCP7IP<2:0> | | | — | ADCP6IP<2:0> | | | 0004 | |
| INTTREG | 00E0 | — | — | — | — | ILR<3:0> | | | | — | VECNUM<6:0> | | | | | | 0000 | | |

Legend: x = unknown value on Reset, — = unimplemented, read as '0'. Reset values are shown in hexadecimal.

TABLE 4-7: INTERRUPT CONTROLLER REGISTER MAP FOR dsPIC33FJ32GS406 AND dsPIC33FJ64GS406 DEVICES

| SFR Name | SFR Addr. | Bit 15 | Bit 14 | Bit 13 | Bit 12 | Bit 11 | Bit 10 | Bit 9 | Bit 8 | Bit 7 | Bit 6 | Bit 5 | Bit 4 | Bit 3 | Bit 2 | Bit 1 | Bit 0 | All Resets | |
|----------|-----------|---------|-------------|----------|---------|---------|-------------|---------|-------|----------|--------------|--------------|---------|---------|--------------|---------|---------|------------|------|
| INTCON1 | 0080 | NSTDIS | OVAERR | OVBERR | COVAERR | COVBERR | OVATE | OVBTE | COVTE | SFTACERR | DIV0ERR | — | MATHERR | ADDRERR | STKERR | OSCFAIL | — | 0000 | |
| INTCON2 | 0082 | ALTIVT | DISI | — | — | — | — | — | — | — | — | — | INT4EP | INT3EP | INT2EP | INT1EP | INT0EP | 0000 | |
| IFS0 | 0084 | — | — | ADIF | U1TXIF | U1RXIF | SP1IF | SP1EIF | T3IF | T2IF | OC2IF | IC2IF | — | T1IF | OC1IF | IC1IF | INT0IF | 0000 | |
| IFS1 | 0086 | U2TXIF | U2RXIF | INT2IF | T5IF | T4IF | OC4IF | OC3IF | — | — | — | — | INT1IF | CNIF | — | MI2C1IF | SI2C1IF | 0000 | |
| IFS2 | 0088 | — | — | — | — | — | — | — | — | — | IC4IF | IC3IF | — | — | — | SPI2IF | SPI2EIF | 0000 | |
| IFS3 | 008A | — | — | — | — | — | QE11IF | PSEMIF | — | — | INT4IF | INT3IF | — | — | MI2C2IF | SI2C2IF | — | 0000 | |
| IFS4 | 008C | — | — | — | — | — | — | PSESMIF | — | — | — | — | — | — | U2EIF | U1EIF | — | 0000 | |
| IFS5 | 008E | PWM2IF | PWM1IF | ADCP12IF | — | — | — | — | — | — | — | — | — | — | — | — | — | 0000 | |
| IFS6 | 0090 | ADCP1IF | ADCP0IF | — | — | — | — | — | — | — | — | — | — | PWM6IF | PWM5IF | PWM4IF | PWM3IF | 0000 | |
| IFS7 | 0092 | — | — | — | — | — | — | — | — | — | — | ADCP7IF | ADCP6IF | ADCP5IF | ADCP4IF | ADCP3IF | ADCP2IF | 0000 | |
| IEC0 | 0094 | — | — | ADIE | U1TXIE | U1RXIE | SP1IE | SP1EIE | T3IE | T2IE | OC2IE | IC2IE | — | T1IE | OC1IE | IC1IE | INT0IE | 0000 | |
| IEC1 | 0096 | U2TXIE | U2RXIE | INT2IE | T5IE | T4IE | OC4IE | OC3IE | — | — | — | — | INT1IE | CNIE | — | MI2C1IE | SI2C1IE | 0000 | |
| IEC2 | 0098 | — | — | — | — | — | — | — | — | — | IC4IE | IC3IE | — | — | — | SPI2IE | SPI2EIE | 0000 | |
| IEC3 | 009A | — | — | — | — | — | QE11IE | PSEMIE | — | — | INT4IE | INT3IE | — | — | MI2C2IE | SI2C2IE | — | 0000 | |
| IEC4 | 009C | — | — | — | — | — | — | PSESMIE | — | — | — | — | — | — | U2EIE | U1EIE | — | 0000 | |
| IEC5 | 009E | PWM2IE | PWM1IE | ADCP12IE | — | — | — | — | — | — | — | — | — | — | — | — | — | 0000 | |
| IEC6 | 00A0 | ADCP1IE | ADCP0IE | — | — | — | — | — | — | — | — | — | — | PWM6IE | PWM5IE | PWM4IE | PWM3IE | 0000 | |
| IEC7 | 00A2 | — | — | — | — | — | — | — | — | — | — | ADCP7IE | ADCP6IE | ADCP5IE | ADCP4IE | ADCP3IE | ADCP2IE | 0000 | |
| IPC0 | 00A4 | — | T1IP<2:0> | | | — | OC1IP<2:0> | | | — | IC1IP<2:0> | | | — | INT0IP<2:0> | | | 4444 | |
| IPC1 | 00A6 | — | T2IP<2:0> | | | — | OC2IP<2:0> | | | — | IC2IP<2:0> | | | — | — | — | — | 4444 | |
| IPC2 | 00A8 | — | U1RXIP<2:0> | | | — | SPI1IP<2:0> | | | — | SPI1EIP<2:0> | | | — | T3IP<2:0> | | | 4444 | |
| IPC3 | 00AA | — | — | — | — | — | — | — | — | — | — | ADIP<2:0> | | | U1TXIP<2:0> | | | 0044 | |
| IPC4 | 00AC | — | CNIP<2:0> | | | — | — | — | — | — | — | MI2C1IP<2:0> | | | SI2C1IP<2:0> | | | 4444 | |
| IPC5 | 00AE | — | — | — | — | — | — | — | — | — | — | — | — | — | INT1IP<2:0> | | | 0004 | |
| IPC6 | 00B0 | — | T4IP<2:0> | | | — | OC4IP<2:0> | | | — | OC3IP<2:0> | | | — | — | — | — | 4444 | |
| IPC7 | 00B2 | — | U2TXIP<2:0> | | | — | U2RXIP<2:0> | | | — | INT2IP<2:0> | | | — | T5IP<2:0> | | | 4444 | |
| IPC8 | 00B4 | — | — | — | — | — | — | — | — | — | — | SPI2IP<2:0> | | | SPI2EIP<2:0> | | | 0044 | |
| IPC9 | 00B6 | — | — | — | — | — | — | — | — | — | IC4IP<2:0> | | | — | IC3IP<2:0> | | | 0440 | |
| IPC12 | 00BC | — | — | — | — | — | — | — | — | — | MI2C2IP<2:0> | | | — | SI2C2IP<2:0> | | | 0440 | |
| IPC13 | 00BE | — | — | — | — | — | — | — | — | — | INT4IP<2:0> | | | — | INT3IP<2:0> | | | 0440 | |
| IPC14 | 00C0 | — | — | — | — | — | — | — | — | — | QE11IP<2:0> | | | — | PSEMIP<2:0> | | | 0440 | |
| IPC16 | 00C4 | — | — | — | — | — | — | — | — | — | U2EIP<2:0> | | | — | U1EIP<2:0> | | | 0440 | |
| IPC18 | 00C8 | — | — | — | — | — | — | — | — | — | PSESMIP<2:0> | | | — | — | — | — | 0040 | |
| IPC23 | 00D2 | — | PWM2IP<2:0> | | | — | PWM1IP<2:0> | | | — | — | — | — | — | — | — | — | — | 4400 |

Legend: × = unknown value on Reset, — = unimplemented, read as '0'. Reset values are shown in hexadecimal.

TABLE 4-7: INTERRUPT CONTROLLER REGISTER MAP FOR dsPIC33FJ32GS406 AND dsPIC33FJ64GS406 DEVICES (CONTINUED)

| SFR Name | SFR Addr. | Bit 15 | Bit 14 | Bit 13 | Bit 12 | Bit 11 | Bit 10 | Bit 9 | Bit 8 | Bit 7 | Bit 6 | Bit 5 | Bit 4 | Bit 3 | Bit 2 | Bit 1 | Bit 0 | All Resets | |
|----------|-----------|--------|--------------|--------|--------|----------|--------------|-------|-------|-------------|--------------|-------|-------|-------|--------------|-------|-------|------------|------|
| IPC24 | 00D4 | — | PWM6IP<2:0> | | | — | PWM5IP<2:0> | | | — | PWM4IP<2:0> | | | — | PWM3IP<2:0> | | | 4444 | |
| IPC27 | 00DA | — | ADCP1IP<2:0> | | | — | ADCP0IP<2:0> | | | — | — | — | — | — | — | — | — | — | 4400 |
| IPC28 | 00DC | — | ADCP5IP<2:0> | | | — | ADCP4IP<2:0> | | | — | ADCP3IP<2:0> | | | — | ADCP2IP<2:0> | | | 4444 | |
| IPC29 | 00DE | — | — | — | — | — | — | — | — | — | ADCP7IP<2:0> | | | — | ADCP6IP<2:0> | | | 0004 | |
| INTTREG | 00E0 | — | — | — | — | ILR<3:0> | | | — | VECNUM<6:0> | | | | | | 0000 | | | |

Legend: x = unknown value on Reset, — = unimplemented, read as '0'. Reset values are shown in hexadecimal.

TABLE 4-8: INTERRUPT CONTROLLER REGISTER MAP FOR dsPIC33FJ32GS610 DEVICES

| SFR Name | SFR Addr. | Bit 15 | Bit 14 | Bit 13 | Bit 12 | Bit 11 | Bit 10 | Bit 9 | Bit 8 | Bit 7 | Bit 6 | Bit 5 | Bit 4 | Bit 3 | Bit 2 | Bit 1 | Bit 0 | All Resets |
|----------|-----------|---------|---------|---------------|---------|---------|--------|--------------|-------|----------|---------|--------------|----------|----------|--------------|---------|---------|------------|
| INTCON1 | 0080 | NSTDIS | OVAERR | OVBERR | COVAERR | COVBERR | OVATE | OVBTE | COVTE | SFTACERR | DIV0ERR | — | MATHERR | ADDRERR | STKERR | OSCFAIL | — | 0000 |
| INTCON2 | 0082 | ALTIVT | DISI | — | — | — | — | — | — | — | — | — | INT4EP | INT3EP | INT2EP | INT1EP | INT0EP | 0000 |
| IFS0 | 0084 | — | — | ADIF | U1TXIF | U1RXIF | SPI1IF | SP1EIF | T3IF | T2IF | OC2IF | IC2IF | — | T1IF | OC1IF | IC1IF | INT0IF | 0000 |
| IFS1 | 0086 | U2TXIF | U2RXIF | INT2IF | T5IF | T4IF | OC4IF | OC3IF | — | — | — | — | INT1IF | CNIF | AC1IF | MI2C1IF | SI2C1IF | 0000 |
| IFS2 | 0088 | — | — | — | — | — | — | — | — | — | IC4IF | IC3IF | — | — | — | SPI2IF | SPI2EIF | 0000 |
| IFS3 | 008A | — | — | — | — | — | QE11IF | PSEMIF | — | — | INT4IF | INT3IF | — | — | MI2C2IF | SI2C2IF | — | 0000 |
| IFS4 | 008C | — | — | — | — | QE12IF | — | PSESMIF | — | — | — | — | — | — | U2EIF | U1EIF | — | 0000 |
| IFS5 | 008E | PWM2IF | PWM1IF | ADCP12IF | — | — | — | — | — | — | — | — | ADCP11IF | ADCP10IF | ADCP9IF | ADCP8IF | — | 0000 |
| IFS6 | 0090 | ADCP1IF | ADCP0IF | — | — | — | — | AC4IF | AC3IF | AC2IF | PWM9IF | PWM8IF | PWM7IF | PWM6IF | PWM5IF | PWM4IF | PWM3IF | 0000 |
| IFS7 | 0092 | — | — | — | — | — | — | — | — | — | — | ADCP7IF | ADCP6IF | ADCP5IF | ADCP4IF | ADCP3IF | ADCP2IF | 0000 |
| IEC0 | 0094 | — | — | ADIE | U1TXIE | U1RXIE | SPI1IE | SP1EIE | T3IE | T2IE | OC2IE | IC2IE | — | T1IE | OC1IE | IC1IE | INT0IE | 0000 |
| IEC1 | 0096 | U2TXIE | U2RXIE | INT2IE | T5IE | T4IE | OC4IE | OC3IE | — | — | — | — | INT1IE | CNIE | AC1IE | MI2C1IE | SI2C1IE | 0000 |
| IEC2 | 0098 | — | — | — | — | — | — | — | — | — | IC4IE | IC3IE | — | — | — | SPI2IE | SPI2EIE | 0000 |
| IEC3 | 009A | — | — | — | — | — | QE11IE | PSEMIE | — | — | INT4IE | INT3IE | — | — | MI2C2IE | SI2C2IE | — | 0000 |
| IEC4 | 009C | — | — | — | — | QE12IE | — | PSESMIE | — | — | — | — | — | — | U2EIE | U1EIE | — | 0000 |
| IEC5 | 009E | PWM2IE | PWM1IE | ADCP12IE | — | — | — | — | — | — | — | — | ADCP11IE | ADCP10IE | ADCP9IE | ADCP8IE | — | 0000 |
| IEC6 | 00A0 | ADCP1IE | ADCP0IE | — | — | — | — | AC4IE | AC3IE | AC2IE | PWM9IE | PWM8IE | PWM7IE | PWM6IE | PWM5IE | PWM4IE | PWM3IE | 0000 |
| IEC7 | 00A2 | — | — | — | — | — | — | — | — | — | — | ADCP7IE | ADCP6IE | ADCP5IE | ADCP4IE | ADCP3IE | ADCP2IE | 0000 |
| IPC0 | 00A4 | — | — | T1IP<2:0> | | — | — | OC1IP<2:0> | | — | — | IC1IP<2:0> | | — | INT0IP<2:0> | | | 4444 |
| IPC1 | 00A6 | — | — | T2IP<2:0> | | — | — | OC2IP<2:0> | | — | — | IC2IP<2:0> | | — | — | — | — | 4444 |
| IPC2 | 00A8 | — | — | U1RXIP<2:0> | | — | — | SPI1IP<2:0> | | — | — | SPI1EIP<2:0> | | — | T3IP<2:0> | | | 4444 |
| IPC3 | 00AA | — | — | — | — | — | — | — | — | — | — | ADIP<2:0> | | — | U1TXIP<2:0> | | | 0044 |
| IPC4 | 00AC | — | — | CNIP<2:0> | | — | — | AC1IP<2:0> | | — | — | MI2C1IP<2:0> | | — | SI2C1IP<2:0> | | | 4444 |
| IPC5 | 00AE | — | — | — | — | — | — | — | — | — | — | — | — | — | INT1IP<2:0> | | | 0004 |
| IPC6 | 00B0 | — | — | T4IP<2:0> | | — | — | OC4IP<2:0> | | — | — | OC3IP<2:0> | | — | — | — | — | 4444 |
| IPC7 | 00B2 | — | — | U2TXIP<2:0> | | — | — | U2RXIP<2:0> | | — | — | INT2IP<2:0> | | — | T5IP<2:0> | | | 4444 |
| IPC8 | 00B4 | — | — | — | — | — | — | — | — | — | — | SPI2IP<2:0> | | — | SPI2EIP<2:0> | | | 0044 |
| IPC9 | 00B6 | — | — | — | — | — | — | IC4IP<2:0> | | — | — | IC3IP<2:0> | | — | — | — | — | 0440 |
| IPC12 | 00BC | — | — | — | — | — | — | MI2C2IP<2:0> | | — | — | SI2C2IP<2:0> | | — | — | — | — | 0440 |
| IPC13 | 00BE | — | — | — | — | — | — | INT4IP<2:0> | | — | — | INT3IP<2:0> | | — | — | — | — | 0440 |
| IPC14 | 00C0 | — | — | — | — | — | — | QE11IP<2:0> | | — | — | PSEMIP<2:0> | | — | — | — | — | 0440 |
| IPC16 | 00C4 | — | — | — | — | — | — | U2EIP<2:0> | | — | — | U1EIP<2:0> | | — | — | — | — | 0440 |
| IPC18 | 00C8 | — | — | QE12IP<2:0> | | — | — | — | — | — | — | PSESMIP<2:0> | | — | — | — | — | 4040 |
| IPC20 | 00CC | — | — | ADCP10IP<2:0> | | — | — | ADCP9IP<2:0> | | — | — | ADCP8IP<2:0> | | — | — | — | — | 4440 |

Legend: × = unknown value on Reset, — = unimplemented, read as '0'. Reset values are shown in hexadecimal.

TABLE 4-8: INTERRUPT CONTROLLER REGISTER MAP FOR dsPIC33FJ32GS610 DEVICES (CONTINUED)

| SFR Name | SFR Addr. | Bit 15 | Bit 14 | Bit 13 | Bit 12 | Bit 11 | Bit 10 | Bit 9 | Bit 8 | Bit 7 | Bit 6 | Bit 5 | Bit 4 | Bit 3 | Bit 2 | Bit 1 | Bit 0 | All Resets | |
|----------|-----------|--------|--------------|--------|--------|----------|--------------|-------|-------|-------|---------------|-------|-------|-------|---------------|-------|-------|------------|------|
| IPC21 | 00CE | — | — | — | — | — | — | — | — | — | ADCP12IP<2:0> | | | — | ADCP11IP<2:0> | | | 0044 | |
| IPC23 | 00D2 | — | PWM2IP<2:0> | | | — | PWM1IP<2:0> | | | — | — | — | — | — | — | — | — | — | 4400 |
| IPC24 | 00D4 | — | PWM6IP<2:0> | | | — | PWM5IP<2:0> | | | — | PWM4IP<2:0> | | | — | PWM3IP<2:0> | | | 4444 | |
| IPC25 | 00D6 | — | AC2IP<2:0> | | | — | PWM9IP<2:0> | | | — | PWM8IP<2:0> | | | — | PWM7IP<2:0> | | | 4444 | |
| IPC26 | 00D8 | — | — | — | — | — | — | — | — | — | AC4IP<2:0> | | | — | AC3IP<2:0> | | | 0044 | |
| IPC27 | 00DA | — | ADCP1IP<2:0> | | | — | ADCP0IP<2:0> | | | — | — | — | — | — | — | — | — | 4400 | |
| IPC28 | 00DC | — | ADCP5IP<2:0> | | | — | ADCP4IP<2:0> | | | — | ADCP3IP<2:0> | | | — | ADCP2IP<2:0> | | | 4444 | |
| IPC29 | 00DE | — | — | — | — | — | — | — | — | — | ADCP7IP<2:0> | | | — | ADCP6IP<2:0> | | | 0044 | |
| INTTREG | 00E0 | — | — | — | — | ILR<3:0> | | | | — | VECNUM<6:0> | | | | | | 0000 | | |

Legend: x = unknown value on Reset, — = unimplemented, read as '0'. Reset values are shown in hexadecimal.

TABLE 4-9: INTERRUPT CONTROLLER REGISTER MAP FOR dsPIC33FJ32GS608

| SFR Name | SFR Addr. | Bit 15 | Bit 14 | Bit 13 | Bit 12 | Bit 11 | Bit 10 | Bit 9 | Bit 8 | Bit 7 | Bit 6 | Bit 5 | Bit 4 | Bit 3 | Bit 2 | Bit 1 | Bit 0 | All Resets | |
|----------|-----------|---------|-------------|----------|---------|---------|-------------|---------|--------|----------|--------------|-------------|---------|---------|--------------|--------------|---------|------------|------|
| INTCON1 | 0080 | NSTDIS | OVAERR | OVBERR | COVAERR | COVBERR | OVATE | OVBTE | COVTE | SFTACERR | DIV0ERR | — | MATHERR | ADDRERR | STKERR | OSCFAIL | — | 0000 | |
| INTCON2 | 0082 | ALTIPT | DISI | — | — | — | — | — | — | — | — | — | INT4EP | INT3EP | INT2EP | INT1EP | INT0EP | 0000 | |
| IFS0 | 0084 | — | — | ADIF | U1TXIF | U1RXIF | SP1IF | SP1EIF | T3IF | T2IF | OC2IF | IC2IF | — | T1IF | OC1IF | IC1IF | INT0IF | 0000 | |
| IFS1 | 0086 | U2TXIF | U2RXIF | INT2IF | T5IF | T4IF | OC4IF | OC3IF | — | — | — | — | INT1IF | CNIF | AC1IF | MI2C1IF | SI2C1IF | 0000 | |
| IFS2 | 0088 | — | — | — | — | — | — | — | — | — | IC4IF | IC3IF | — | — | — | SPI2IF | SPI2EIF | 0000 | |
| IFS3 | 008A | — | — | — | — | — | — | QE11IF | PSEMIF | — | — | INT4IF | INT3IF | — | — | MI2C2IF | SI2C2IF | 0000 | |
| IFS4 | 008C | — | — | — | — | QE12IF | — | PSESMIF | — | — | — | — | — | — | — | U2EIF | U1EIF | 0000 | |
| IFS5 | 008E | PWM2IF | PWM1IF | ADCP12IF | — | — | — | — | — | — | — | — | — | — | — | — | ADCP8IF | 0000 | |
| IFS6 | 0090 | ADCP1IF | ADCP0IF | — | — | — | — | AC4IF | AC3IF | AC2IF | — | PWM8IF | PWM7IF | PWM6IF | PWM5IF | PWM4IF | PWM3IF | 0000 | |
| IFS7 | 0092 | — | — | — | — | — | — | — | — | — | — | ADCP7IF | ADCP6IF | ADCP5IF | ADCP4IF | ADCP3IF | ADCP2IF | 0000 | |
| IEC0 | 0094 | — | — | ADIE | U1TXIE | U1RXIE | SP1IE | SP1EIE | T3IE | T2IE | OC2IE | IC2IE | — | T1IE | OC1IE | IC1IE | INT0IE | 0000 | |
| IEC1 | 0096 | U2TXIE | U2RXIE | INT2IE | T5IE | T4IE | OC4IE | OC3IE | — | — | — | — | INT1IE | CNIE | — | MI2C1IE | SI2C1IE | 0000 | |
| IEC2 | 0098 | — | — | — | — | — | — | — | — | — | IC4IE | IC3IE | — | — | — | SPI2IE | SPI2EIE | 0000 | |
| IEC3 | 009A | — | — | — | — | — | — | QE11IE | PSEMIE | — | — | INT4IE | INT3IE | — | — | MI2C2IE | SI2C2IE | 0000 | |
| IEC4 | 009C | — | — | — | — | QE12IE | — | PSESMIE | — | — | — | — | — | — | — | U2EIE | U1EIE | 0000 | |
| IEC5 | 009E | PWM2IE | PWM1IE | ADCP12IE | — | — | — | — | — | — | — | — | — | — | — | — | ADCP8IE | 0000 | |
| IEC6 | 00A0 | ADCP1IE | ADCP0IE | — | — | — | — | AC4IE | AC3IE | AC2IE | — | PWM8IE | PWM7IE | PWM6IE | PWM5IE | PWM4IE | PWM3IE | 0000 | |
| IEC7 | 00A2 | — | — | — | — | — | — | — | — | — | — | ADCP7IE | ADCP6IE | ADCP5IE | ADCP4IE | ADCP3IE | ADCP2IE | 0000 | |
| IPC0 | 00A4 | — | T1IP<2:0> | | | — | OC1IP<2:0> | | | — | IC1IP<2:0> | | | — | INT0IP<2:0> | | | 4444 | |
| IPC1 | 00A6 | — | T2IP<2:0> | | | — | OC2IP<2:0> | | | — | IC2IP<2:0> | | | — | — | — | — | 4444 | |
| IPC2 | 00A8 | — | U1RXIP<2:0> | | | — | SPI1IP<2:0> | | | — | SPI1EIP<2:0> | | | — | T3IP<2:0> | | | 4444 | |
| IPC3 | 00AA | — | — | — | — | — | — | — | — | — | — | ADIP<2:0> | | | — | U1TXIP<2:0> | | | 0044 |
| IPC4 | 00AC | — | CNIP<2:0> | | | — | AC1IP<2:0> | | | — | MI2C1IP<2:0> | | | — | SI2C1IP<2:0> | | | 4444 | |
| IPC5 | 00AE | — | — | — | — | — | — | — | — | — | — | — | — | — | — | INT1IP<2:0> | | | 0004 |
| IPC6 | 00B0 | — | T4IP<2:0> | | | — | OC4IP<2:0> | | | — | OC3IP<2:0> | | | — | — | — | — | 4444 | |
| IPC7 | 00B2 | — | U2TXIP<2:0> | | | — | U2RXIP<2:0> | | | — | INT2IP<2:0> | | | — | T5IP<2:0> | | | 4444 | |
| IPC8 | 00B4 | — | — | — | — | — | — | — | — | — | — | SPI2IP<2:0> | | | — | SPI2EIP<2:0> | | | 0044 |
| IPC9 | 00B6 | — | — | — | — | — | — | — | — | — | IC4IP<2:0> | | | — | IC3IP<2:0> | | | 0440 | |
| IPC12 | 00BC | — | — | — | — | — | — | — | — | — | MI2C2IP<2:0> | | | — | SI2C2IP<2:0> | | | 0440 | |
| IPC13 | 00BE | — | — | — | — | — | — | — | — | — | INT4IP<2:0> | | | — | INT3IP<2:0> | | | 0440 | |
| IPC14 | 00C0 | — | — | — | — | — | — | — | — | — | QE11IP<2:0> | | | — | PSEMIP<2:0> | | | 0440 | |
| IPC16 | 00C4 | — | — | — | — | — | — | — | — | — | U2EIP<2:0> | | | — | U1EIP<2:0> | | | 0440 | |
| IPC18 | 00C8 | — | QE12IP<2:0> | | | — | — | — | — | — | PSESMIP<2:0> | | | — | — | | | 4040 | |
| IPC20 | 00CC | — | — | — | — | — | — | — | — | — | ADCP8IP<2:0> | | | — | — | | | 0040 | |

Legend: × = unknown value on Reset, — = unimplemented, read as '0'. Reset values are shown in hexadecimal.

TABLE 4-9: INTERRUPT CONTROLLER REGISTER MAP FOR dsPIC33FJ32GS608 (CONTINUED)

| SFR Name | SFR Addr. | Bit 15 | Bit 14 | Bit 13 | Bit 12 | Bit 11 | Bit 10 | Bit 9 | Bit 8 | Bit 7 | Bit 6 | Bit 5 | Bit 4 | Bit 3 | Bit 2 | Bit 1 | Bit 0 | All Resets | |
|----------|-----------|--------|---------------|--------|--------|----------|--------------|-------|-------|-------|---------------|-------|-------|-------|--------------|-------|-------|------------|------|
| IPC21 | 00CE | — | — | — | — | — | — | — | — | — | ADCP12IP<2:0> | | | — | — | — | — | 0040 | |
| IPC23 | 00D2 | — | PWM2IP<2:0> | | | — | PWM1IP<2:0> | | | — | — | — | — | — | — | — | — | — | 4400 |
| IPC24 | 00D4 | — | PWM6IP<2:0> | | | — | PWM5IP<2:0> | | | — | PWM4IP<2:0> | | | — | PWM3IP<2:0> | | | 4444 | |
| IPC25 | 00D6 | — | AC2IP<2:0> | | | — | — | — | — | — | PWM8IP<2:0> | | | — | PWM7IP<2:0> | | | 4044 | |
| IPC26 | 00D8 | — | — | — | — | — | — | — | — | — | AC4IP<2:0> | | | — | AC3IP<2:0> | | | 0044 | |
| IPC27 | 00DA | — | ADCP11IP<2:0> | | | — | ADCP0IP<2:0> | | | — | — | — | — | — | — | — | — | — | 4400 |
| IPC28 | 00DC | — | ADCP5IP<2:0> | | | — | ADCP4IP<2:0> | | | — | ADCP3IP<2:0> | | | — | ADCP2IP<2:0> | | | 4444 | |
| IPC29 | 00DE | — | — | — | — | — | — | — | — | — | ADCP7IP<2:0> | | | — | ADCP6IP<2:0> | | | 0044 | |
| INTTREG | 00E0 | — | — | — | — | ILR<3:0> | | | | — | VECNUM<6:0> | | | | | | 0000 | | |

Legend: x = unknown value on Reset, — = unimplemented, read as '0'. Reset values are shown in hexadecimal.

TABLE 4-10: INTERRUPT CONTROLLER REGISTER MAP FOR dsPIC33FJ32GS606 DEVICES

| SFR Name | SFR Addr. | Bit 15 | Bit 14 | Bit 13 | Bit 12 | Bit 11 | Bit 10 | Bit 9 | Bit 8 | Bit 7 | Bit 6 | Bit 5 | Bit 4 | Bit 3 | Bit 2 | Bit 1 | Bit 0 | All Resets |
|----------|-----------|---------|---------|-------------|---------|---------|--------|--------------|-------|----------|---------|---------------|---------|---------|--------------|---------|---------|------------|
| INTCON1 | 0080 | NSTDIS | OVAERR | OVBERR | COVAERR | COVBERR | OVATE | OVBTE | COVTE | SFTACERR | DIV0ERR | — | MATHERR | ADDRERR | STKERR | OSCFAIL | — | 0000 |
| INTCON2 | 0082 | ALTIPT | DISI | — | — | — | — | — | — | — | — | — | INT4EP | INT3EP | INT2EP | INT1EP | INT0EP | 0000 |
| IFS0 | 0084 | — | — | ADIF | U1TXIF | U1RXIF | SPI1IF | SPI1EIF | T3IF | T2IF | OC2IF | IC2IF | — | T1IF | OC1IF | IC1IF | INT0IF | 0000 |
| IFS1 | 0086 | U2TXIF | U2RXIF | INT2IF | T5IF | T4IF | OC4IF | OC3IF | — | — | — | — | INT1IF | CNIF | AC1IF | MI2C1IF | SI2C1IF | 0000 |
| IFS2 | 0088 | — | — | — | — | — | — | — | — | — | IC4IF | IC3IF | — | — | — | SPI2IF | SPI2EIF | 0000 |
| IFS3 | 008A | — | — | — | — | — | QE11IF | PSEMIF | — | — | INT4IF | INT3IF | — | — | MI2C2IF | SI2C2IF | — | 0000 |
| IFS4 | 008C | — | — | — | — | QE12IF | — | PSESMIF | — | — | — | — | — | — | U2EIF | U1EIF | — | 0000 |
| IFS5 | 008E | PWM2IF | PWM1IF | ADCP12IF | — | — | — | — | — | — | — | — | — | — | — | — | — | 0000 |
| IFS6 | 0090 | ADCP1IF | ADCP0IF | — | — | — | — | AC4IF | AC3IF | AC2IF | — | — | — | PWM6IF | PWM5IF | PWM4IF | PWM3IF | 0000 |
| IFS7 | 0092 | — | — | — | — | — | — | — | — | — | — | ADCP7IF | ADCP6IF | ADCP5IF | ADCP4IF | ADCP3IF | ADCP2IF | 0000 |
| IEC0 | 0094 | — | — | ADIE | U1TXIE | U1RXIE | SPI1IE | SPI1EIE | T3IE | T2IE | OC2IE | IC2IE | — | T1IE | OC1IE | IC1IE | INT0IE | 0000 |
| IEC1 | 0096 | U2TXIE | U2RXIE | INT2IE | T5IE | T4IE | OC4IE | OC3IE | — | — | — | — | INT1IE | CNIE | AC1IE | MI2C1IE | SI2C1IE | 0000 |
| IEC2 | 0098 | — | — | — | — | — | — | — | — | — | IC4IE | IC3IE | — | — | — | SPI2IE | SPI2EIE | 0000 |
| IEC3 | 009A | — | — | — | — | — | QE11IE | PSEMIE | — | — | INT4IE | INT3IE | — | — | MI2C2IE | SI2C2IE | — | 0000 |
| IEC4 | 009C | — | — | — | — | QE12IE | — | PSESMIE | — | — | — | — | — | — | U2EIE | U1EIE | — | 0000 |
| IEC5 | 009E | PWM2IE | PWM1IE | ADCP12IE | — | — | — | — | — | — | — | — | — | — | — | — | — | 0000 |
| IEC6 | 00A0 | ADCP1IE | ADCP0IE | — | — | — | — | AC4IE | AC3IE | AC2IE | — | — | — | PWM6IE | PWM5IE | PWM4IE | PWM3IE | 0000 |
| IEC7 | 00A2 | — | — | — | — | — | — | — | — | — | — | ADCP7IE | ADCP6IE | ADCP5IE | ADCP4IE | ADCP3IE | ADCP2IE | 0000 |
| IPC0 | 00A4 | — | — | T1IP<2:0> | | — | — | OC1IP<2:0> | | — | — | IC1IP<2:0> | | — | INT0IP<2:0> | | | 4444 |
| IPC1 | 00A6 | — | — | T2IP<2:0> | | — | — | OC2IP<2:0> | | — | — | IC2IP<2:0> | | — | — | — | — | 4440 |
| IPC2 | 00A8 | — | — | U1RXIP<2:0> | | — | — | SPI1IP<2:0> | | — | — | SPI1EIP<2:0> | | — | T3IP<2:0> | | | 4444 |
| IPC3 | 00AA | — | — | — | — | — | — | — | — | — | — | ADIP<2:0> | | — | U1TXIP<2:0> | | | 0044 |
| IPC4 | 00AC | — | — | CNIP<2:0> | | — | — | AC1IP<2:0> | | — | — | MI2C1IP<2:0> | | — | SI2C1IP<2:0> | | | 4444 |
| IPC5 | 00AE | — | — | — | — | — | — | — | — | — | — | — | — | — | INT1IP<2:0> | | | 0004 |
| IPC6 | 00B0 | — | — | T4IP<2:0> | | — | — | OC4IP<2:0> | | — | — | OC3IP<2:0> | | — | — | — | — | 4440 |
| IPC7 | 00B2 | — | — | U2TXIP<2:0> | | — | — | U2RXIP<2:0> | | — | — | INT2IP<2:0> | | — | T5IP<2:0> | | | 4444 |
| IPC8 | 00B4 | — | — | — | — | — | — | — | — | — | — | SPI2IP<2:0> | | — | SPI2EIP<2:0> | | | 0044 |
| IPC9 | 00B6 | — | — | — | — | — | — | IC4IP<2:0> | | — | — | IC3IP<2:0> | | — | — | — | — | 0440 |
| IPC12 | 00BC | — | — | — | — | — | — | MI2C2IP<2:0> | | — | — | SI2C2IP<2:0> | | — | — | — | — | 0440 |
| IPC13 | 00BE | — | — | — | — | — | — | INT4IP<2:0> | | — | — | INT3IP<2:0> | | — | — | — | — | 0440 |
| IPC14 | 00C0 | — | — | — | — | — | — | QE11IP<2:0> | | — | — | PSEMIP<2:0> | | — | — | — | — | 0440 |
| IPC16 | 00C4 | — | — | — | — | — | — | U2EIP<2:0> | | — | — | U1EIP<2:0> | | — | — | — | — | 0440 |
| IPC18 | 00C8 | — | — | QE12IP<2:0> | | — | — | — | — | — | — | PSESMIP<2:0> | | — | — | — | — | 4040 |
| IPC21 | 00CE | — | — | — | — | — | — | — | — | — | — | ADCP12IP<2:0> | | — | — | — | — | 0040 |

Legend: × = unknown value on Reset, — = unimplemented, read as '0'. Reset values are shown in hexadecimal.

TABLE 4-10: INTERRUPT CONTROLLER REGISTER MAP FOR dsPIC33FJ32GS606 DEVICES (CONTINUED)

| SFR Name | SFR Addr. | Bit 15 | Bit 14 | Bit 13 | Bit 12 | Bit 11 | Bit 10 | Bit 9 | Bit 8 | Bit 7 | Bit 6 | Bit 5 | Bit 4 | Bit 3 | Bit 2 | Bit 1 | Bit 0 | All Resets | |
|----------|-----------|--------|--------------|--------|--------|----------|--------------|-------|-------|-------------|--------------|-------|-------|-------|--------------|-------|-------|------------|------|
| IPC23 | 00D2 | — | PWM2IP<2:0> | | | — | PWM1IP<2:0> | | | — | — | — | — | — | — | — | — | — | 4400 |
| IPC24 | 00D4 | — | PWM6IP<2:0> | | | — | PWM5IP<2:0> | | | — | PWM4IP<2:0> | | | — | PWM3IP<2:0> | | | 4444 | |
| IPC25 | 00D6 | — | AC2IP<2:0> | | | — | — | — | — | — | — | — | — | — | — | — | — | — | 4000 |
| IPC26 | 00D8 | — | — | — | — | — | — | — | — | — | AC4IP<2:0> | | | — | AC3IP<2:0> | | | 0044 | |
| IPC27 | 00DA | — | ADCP1IP<2:0> | | | — | ADCP0IP<2:0> | | | — | — | — | — | — | — | — | — | — | 4400 |
| IPC28 | 00DC | — | ADCP5IP<2:0> | | | — | ADCP4IP<2:0> | | | — | ADCP3IP<2:0> | | | — | ADCP2IP<2:0> | | | 4444 | |
| IPC29 | 00DE | — | — | — | — | — | — | — | — | — | ADCP7IP<2:0> | | | — | ADCP6IP<2:0> | | | 0004 | |
| INTTREG | 00E0 | — | — | — | — | ILR<3:0> | | | — | VECNUM<6:0> | | | | | | 0000 | | | |

Legend: x = unknown value on Reset, — = unimplemented, read as '0'. Reset values are shown in hexadecimal.

TABLE 4-11: TIMERS REGISTER MAP

| SFR Name | SFR Addr. | Bit 15 | Bit 14 | Bit 13 | Bit 12 | Bit 11 | Bit 10 | Bit 9 | Bit 8 | Bit 7 | Bit 6 | Bit 5 | Bit 4 | Bit 3 | Bit 2 | Bit 1 | Bit 0 | All Resets |
|----------|-----------|--|--------|--------|--------|--------|--------|-------|-------|-------|-------|------------|-------|-------|-------|-------|-------|------------|
| TMR1 | 0100 | Timer1 Register | | | | | | | | | | | | | | | | 0000 |
| PR1 | 0102 | Period Register 1 | | | | | | | | | | | | | | | | FFFF |
| T1CON | 0104 | TON | — | TSIDL | — | — | — | — | — | — | TGATE | TCKPS<1:0> | — | TSYNC | TCS | — | 0000 | |
| TMR2 | 0106 | Timer2 Register | | | | | | | | | | | | | | | | 0000 |
| TMR3HLD | 0108 | Timer3 Holding Register (for 32-bit timer operations only) | | | | | | | | | | | | | | | | xxxx |
| TMR3 | 010A | Timer3 Register | | | | | | | | | | | | | | | | 0000 |
| PR2 | 010C | Period Register 2 | | | | | | | | | | | | | | | | FFFF |
| PR3 | 010E | Period Register 3 | | | | | | | | | | | | | | | | FFFF |
| T2CON | 0110 | TON | — | TSIDL | — | — | — | — | — | — | TGATE | TCKPS<1:0> | T32 | — | TCS | — | 0000 | |
| T3CON | 0112 | TON | — | TSIDL | — | — | — | — | — | — | TGATE | TCKPS<1:0> | — | — | TCS | — | 0000 | |
| TMR4 | 0114 | Timer4 Register | | | | | | | | | | | | | | | | 0000 |
| TMR5HLD | 0116 | Timer5 Holding Register (for 32-bit timer operations only) | | | | | | | | | | | | | | | | xxxx |
| TMR5 | 0118 | Timer5 Register | | | | | | | | | | | | | | | | 0000 |
| PR4 | 011A | Period Register 4 | | | | | | | | | | | | | | | | FFFF |
| PR5 | 011C | Period Register 5 | | | | | | | | | | | | | | | | FFFF |
| T4CON | 011E | TON | — | TSIDL | — | — | — | — | — | — | TGATE | TCKPS<1:0> | T32 | — | TCS | — | 0000 | |
| T5CON | 0120 | TON | — | TSIDL | — | — | — | — | — | — | TGATE | TCKPS<1:0> | — | — | TCS | — | 0000 | |

Legend: x = unknown value on Reset, — = unimplemented, read as '0'. Reset values are shown in hexadecimal.

TABLE 4-12: INPUT CAPTURE REGISTER MAP

| SFR Name | SFR Addr. | Bit 15 | Bit 14 | Bit 13 | Bit 12 | Bit 11 | Bit 10 | Bit 9 | Bit 8 | Bit 7 | Bit 6 | Bit 5 | Bit 4 | Bit 3 | Bit 2 | Bit 1 | Bit 0 | All Resets |
|----------|-----------|--------------------------|--------|--------|--------|--------|--------|-------|-------|-------|----------|-------|-------|----------|-------|-------|-------|------------|
| IC1BUF | 0140 | Input 1 Capture Register | | | | | | | | | | | | | | | | xxxx |
| IC1CON | 0142 | — | — | ICSIDL | — | — | — | — | — | ICTMR | ICI<1:0> | ICOV | ICBNE | ICM<2:0> | | | 0000 | |
| IC2BUF | 0144 | Input 2 Capture Register | | | | | | | | | | | | | | | | xxxx |
| IC2CON | 0146 | — | — | ICSIDL | — | — | — | — | — | ICTMR | ICI<1:0> | ICOV | ICBNE | ICM<2:0> | | | 0000 | |
| IC3BUF | 0148 | Input 3 Capture Register | | | | | | | | | | | | | | | | xxxx |
| IC3CON | 014A | — | — | ICSIDL | — | — | — | — | — | ICTMR | ICI<1:0> | ICOV | ICBNE | ICM<2:0> | | | 0000 | |
| IC4BUF | 014C | Input 4 Capture Register | | | | | | | | | | | | | | | | xxxx |
| IC4CON | 014E | — | — | ICSIDL | — | — | — | — | — | ICTMR | ICI<1:0> | ICOV | ICBNE | ICM<2:0> | | | 0000 | |

Legend: x = unknown value on Reset, — = unimplemented, read as '0'. Reset values are shown in hexadecimal.

TABLE 4-13: OUTPUT COMPARE REGISTER MAP

| SFR Name | SFR Addr. | Bit 15 | Bit 14 | Bit 13 | Bit 12 | Bit 11 | Bit 10 | Bit 9 | Bit 8 | Bit 7 | Bit 6 | Bit 5 | Bit 4 | Bit 3 | Bit 2 | Bit 1 | Bit 0 | All Resets | |
|----------|-----------|-------------------------------------|--------|--------|--------|--------|--------|-------|-------|-------|-------|-------|-------|--------|----------|-------|-------|------------|------|
| OC1RS | 0180 | Output Compare 1 Secondary Register | | | | | | | | | | | | | | | | | xxxx |
| OC1R | 0182 | Output Compare 1 Register | | | | | | | | | | | | | | | | | xxxx |
| OC1CON | 0184 | — | — | OCSIDL | — | — | — | — | — | — | — | — | OCFLT | OCTSEL | OCM<2:0> | | 0000 | | |
| OC2RS | 0186 | Output Compare 2 Secondary Register | | | | | | | | | | | | | | | | | xxxx |
| OC2R | 0188 | Output Compare 2 Register | | | | | | | | | | | | | | | | | xxxx |
| OC2CON | 018A | — | — | OCSIDL | — | — | — | — | — | — | — | — | OCFLT | OCTSEL | OCM<2:0> | | 0000 | | |
| OC3RS | 018C | Output Compare 3 Secondary Register | | | | | | | | | | | | | | | | | xxxx |
| OC3R | 018E | Output Compare 3 Register | | | | | | | | | | | | | | | | | xxxx |
| OC3CON | 0190 | — | — | OCSIDL | — | — | — | — | — | — | — | — | OCFLT | OCTSEL | OCM<2:0> | | 0000 | | |
| OC4RS | 0192 | Output Compare 4 Secondary Register | | | | | | | | | | | | | | | | | xxxx |
| OC4R | 0194 | Output Compare 4 Register | | | | | | | | | | | | | | | | | xxxx |
| OC4CON | 0196 | — | — | OCSIDL | — | — | — | — | — | — | — | — | OCFLT | OCTSEL | OCM<2:0> | | 0000 | | |

Legend: x = unknown value on Reset, — = unimplemented, read as '0'. Reset values are shown in hexadecimal.

TABLE 4-14: QE1 REGISTER MAP

| SFR Name | SFR Addr. | Bit 15 | Bit 14 | Bit 13 | Bit 12 | Bit 11 | Bit 10 | Bit 9 | Bit 8 | Bit 7 | Bit 6 | Bit 5 | Bit 4 | Bit 3 | Bit 2 | Bit 1 | Bit 0 | All Resets | |
|----------|-----------|------------------------|--------|---------|--------|--------|-----------|-------|-------|-----------|--------|-------------|-------|--------|-------|----------|-------|------------|------|
| QE1CON | 01E0 | CNTERR | — | QEISIDL | INDX | UPDN | QEIM<2:0> | | SWPAB | PCDOUT | TQGATE | TQCKPS<1:0> | | POSRES | TQCS | UPDN_SRC | | 0000 | |
| DFLT1CON | 01E2 | — | — | — | — | — | IMV<1:0> | CEID | QEOUT | QECK<2:0> | | | — | — | — | — | — | 0000 | |
| POS1CNT | 01E4 | Position Counter<15:0> | | | | | | | | | | | | | | | | | 0000 |
| MAX1CNT | 01E6 | Maximum Count<15:0> | | | | | | | | | | | | | | | | | FFFF |

Legend: x = unknown value on Reset, — = unimplemented, read as '0'. Reset values are shown in hexadecimal.

TABLE 4-15: QE2 REGISTER MAP

| SFR Name | SFR Addr. | Bit 15 | Bit 14 | Bit 13 | Bit 12 | Bit 11 | Bit 10 | Bit 9 | Bit 8 | Bit 7 | Bit 6 | Bit 5 | Bit 4 | Bit 3 | Bit 2 | Bit 1 | Bit 0 | All Resets | |
|----------|-----------|------------------------|--------|---------|--------|--------|-----------|-------|-------|-----------|--------|-------------|-------|--------|-------|----------|-------|------------|------|
| QE2CON | 01F0 | CNTERR | — | QEISIDL | INDX | UPDN | QEIM<2:0> | | SWPAB | PCDOUT | TQGATE | TQCKPS<1:0> | | POSRES | TQCS | UPDN_SRC | | 0000 | |
| DFLT2CON | 01F2 | — | — | — | — | — | IMV<1:0> | CEID | QEOUT | QECK<2:0> | | | — | — | — | — | — | 0000 | |
| POS2CNT | 01F4 | Position Counter<15:0> | | | | | | | | | | | | | | | | | 0000 |
| MAX2CNT | 01F6 | Maximum Count<15:0> | | | | | | | | | | | | | | | | | FFFF |

Legend: x = unknown value on Reset, — = unimplemented, read as '0'. Reset values are shown in hexadecimal.

TABLE 4-16: HIGH-SPEED PWM REGISTER MAP

| File Name | SFR Addr. | Bit 15 | Bit 14 | Bit 13 | Bit 12 | Bit 11 | Bit 10 | Bit 9 | Bit 8 | Bit 7 | Bit 6 | Bit 5 | Bit 4 | Bit 3 | Bit 2 | Bit 1 | Bit 0 | All Resets |
|-----------|-----------|----------------|--------|--------|--------|--------|--------|---------|-----------|--------|--------------|-------|-------|-------------|--------------|-------|-------|------------|
| PTCON | 0400 | PTEN | — | PTSIDL | SESTAT | SEIEN | EIPU | SYNCPOL | SYNCOEN | SYNCEN | SYNCSRC<2:0> | | | SEVTPS<3:0> | | | 0000 | |
| PTCON2 | 0402 | — | — | — | — | — | — | — | — | — | — | — | — | — | PCLKDIV<2:0> | | 0000 | |
| PTPER | 0404 | PTPER<15:0> | | | | | | | | | | | | | | | FFF8 | |
| SEVTCMP | 0406 | SEVTCMP<15:3> | | | | | | | | | | | | | | | 0000 | |
| MDC | 040A | MDC<15:0> | | | | | | | | | | | | | | | 0000 | |
| STCON | 040E | — | — | — | SESTAT | SEIEN | EIPU | SYNCPOL | SYNCOEN | SYNCEN | SYNCSRC<2:0> | | | SEVTPS<3:0> | | | 0000 | |
| STCON2 | 0410 | — | — | — | — | — | — | — | — | — | — | — | — | — | PCLKDIV<2:0> | | 0000 | |
| STPER | 0412 | STPER<15:0> | | | | | | | | | | | | | | | FFF8 | |
| SSEVTCMP | 0414 | SSEVTCMP<15:3> | | | | | | | | | | | | | | | 0000 | |
| CHOP | 041A | CHPCLKEN | — | — | — | — | — | — | CHOP<9:3> | | | | | | — | — | — | 0000 |

Legend: x = unknown value on Reset, — = unimplemented, read as '0'. Reset values are shown in hexadecimal.

TABLE 4-17: HIGH-SPEED PWM GENERATOR 1 REGISTER MAP

| File Name | SFR Addr. | Bit 15 | Bit 14 | Bit 13 | Bit 12 | Bit 11 | Bit 10 | Bit 9 | Bit 8 | Bit 7 | Bit 6 | Bit 5 | Bit 4 | Bit 3 | Bit 2 | Bit 1 | Bit 0 | All Resets | | |
|-----------|-----------|---------------|------------|---------------|--------|---------------|---------|--------|--------|-------------|--------------|--------------|-------|------------|--------|-------------|--------|------------|------|------|
| PWMCON1 | 0420 | FLTSTAT | CLSTAT | TRGSTAT | FLTIEN | CLIEN | TRGIEN | ITB | MDCS | DTC<1:0> | | DTCP | — | MTBS | CAM | XPRES | IUE | 0000 | | |
| IOCON1 | 0422 | PENH | PENL | POLH | POLL | PMOD<1:0> | | OVRENH | OVRENL | OVRDAT<1:0> | | FLTDAT<1:0> | | CLDAT<1:0> | | SWAP | OSYNC | 0000 | | |
| FCLCON1 | 0424 | IFLTMOD | CLSRC<4:0> | | | | | CLPOL | CLMOD | FLTSRC<4:0> | | | | | FLTPOL | FLTMOD<1:0> | | 0000 | | |
| PDC1 | 0426 | PDC1<15:0> | | | | | | | | | | | | | | | 0000 | | | |
| PHASE1 | 0428 | PHASE1<15:0> | | | | | | | | | | | | | | | 0000 | | | |
| DTR1 | 042A | — | — | DTR1<13:0> | | | | | | | | | | | 0000 | | | | | |
| ALTDTR1 | 042C | — | — | ALTDTR1<13:0> | | | | | | | | | | | 0000 | | | | | |
| SDC1 | 042E | SDC1<15:0> | | | | | | | | | | | | | | | 0000 | | | |
| SPHASE1 | 0430 | SPHASE1<15:0> | | | | | | | | | | | | | | | 0000 | | | |
| TRIG1 | 0432 | TRGCMP<15:3> | | | | | | | | | | | | | | | — | — | — | 0000 |
| TRGCON1 | 0434 | TRGDIV<3:0> | | | — | — | — | — | DTM | — | TRGSTRT<5:0> | | | | | | | 0000 | | |
| STRIG1 | 0436 | STRGCMP<15:3> | | | | | | | | | | | | | | | — | — | — | 0000 |
| PWMCAP1 | 0438 | PWMCAP1<15:3> | | | | | | | | | | | | | | | — | — | — | 0000 |
| LEBCON1 | 043A | PHR | PHF | PLR | PLF | FLTLEBEN | CLLEBEN | — | — | — | — | BCH | BCL | BPHH | BPHL | BPLH | BPLL | 0000 | | |
| LEBDLY1 | 043C | — | — | — | — | LEB<11:3> | | | | | | | | | | — | — | — | 0000 | |
| AUXCON1 | 043E | HRPDIS | HRDDIS | — | — | BLANKSEL<3:0> | | | | — | — | CHOPSEL<3:0> | | | | CHOPHEN | CHOPLN | 0000 | | |

Legend: x = unknown value on Reset, — = unimplemented, read as '0'. Reset values are shown in hexadecimal.

TABLE 4-18: HIGH-SPEED PWM GENERATOR 2 REGISTER MAP

| File Name | SFR Addr. | Bit 15 | Bit 14 | Bit 13 | Bit 12 | Bit 11 | Bit 10 | Bit 9 | Bit 8 | Bit 7 | Bit 6 | Bit 5 | Bit 4 | Bit 3 | Bit 2 | Bit 1 | Bit 0 | All Resets | | |
|-----------|-----------|---------------|------------|---------------|--------|---------------|---------|--------|-------------|-------------|-------|--------------|--------|-------------|-------|---------|--------|------------|------|------|
| PWMCON2 | 0440 | FLTSTAT | CLSTAT | TRGSTAT | FLTIEN | CLIEEN | TRGIEEN | ITB | MDCS | DTC<1:0> | | DTCP | — | MTBS | CAM | XPRES | IUE | 0000 | | |
| IOCON2 | 0442 | PENH | PENL | POLH | POLL | PMDIV<1:0> | | OVRENH | OVRENL | OVRDAT<1:0> | | FLTDAT<1:0> | | CLDAT<1:0> | | SWAP | OSYNC | 0000 | | |
| FCLCON2 | 0444 | IFLTMOD | CLSRC<4:0> | | | | CLPOL | CLMOD | FLTSRC<4:0> | | | | FLTPOL | FLTMOD<1:0> | | | 0000 | | | |
| PDC2 | 0446 | PDC2<15:0> | | | | | | | | | | | | | | | | | 0000 | |
| PHASE2 | 0448 | PHASE2<15:0> | | | | | | | | | | | | | | | | | 0000 | |
| DTR2 | 044A | — | — | DTR2<13:0> | | | | | | | | | | | | | | 0000 | | |
| ALTDTR2 | 044C | — | — | ALTDTR2<13:0> | | | | | | | | | | | | | | 0000 | | |
| SDC2 | 044E | SDC2<15:0> | | | | | | | | | | | | | | | | | 0000 | |
| SPHASE2 | 0450 | SPHASE2<15:0> | | | | | | | | | | | | | | | | | 0000 | |
| TRIG2 | 0452 | TRGCMP<15:3> | | | | | | | | | | | | | — | — | — | 0000 | | |
| TRGCON2 | 0454 | TRGDIV<3:0> | | | | — | — | — | — | DTM | — | TRGSTRT<5:0> | | | | | | 0000 | | |
| STRIG2 | 0456 | STRGCMP<15:3> | | | | | | | | | | | | | — | — | — | 0000 | | |
| PWMCAP2 | 0458 | PWMCAP2<15:3> | | | | | | | | | | | | | | | | | 0000 | |
| LEBCON2 | 045A | PHR | PHF | PLR | PLF | FLTLEBEN | CLLEBEN | — | — | — | — | BCH | BCL | BPHH | BPHL | BPLH | BPLL | 0000 | | |
| LEBDLY2 | 045C | — | — | — | — | LEB<11:3> | | | | | | | | | | | — | — | — | 0000 |
| AUXCON2 | 045E | HRPDIS | HRDDIS | — | — | BLANKSEL<3:0> | | | | — | — | CHOPSEL<3:0> | | | | CHOPHEN | CHOPLN | 0000 | | |

Legend: x = unknown value on Reset, — = unimplemented, read as '0'. Reset values are shown in hexadecimal.

TABLE 4-19: HIGH-SPEED PWM GENERATOR 3 REGISTER MAP

| File Name | SFR Addr. | Bit 15 | Bit 14 | Bit 13 | Bit 12 | Bit 11 | Bit 10 | Bit 9 | Bit 8 | Bit 7 | Bit 6 | Bit 5 | Bit 4 | Bit 3 | Bit 2 | Bit 1 | Bit 0 | All Resets | |
|-----------|-----------|---------------|------------|---------------|--------|---------------|---------|--------|-------------|-------------|-------|--------------|--------|-------------|-------|---------|---------|------------|------|
| PWMCON3 | 0460 | FLTSTAT | CLSTAT | TRGSTAT | FLTIEN | CLIEN | TRGIEN | ITB | MDCS | DTC<1:0> | | DTCP | — | MTBS | CAM | XPRES | IUE | 0000 | |
| IOCON3 | 0462 | PENH | PENL | POLH | POLL | PMOD<1:0> | | OVRENH | OVRENL | OVRDAT<1:0> | | FLTDAT<1:0> | | CLDAT<1:0> | | SWAP | OSYNC | 0000 | |
| FCLCON3 | 0464 | IFLTMOD | CLSRC<4:0> | | | | CLPOL | CLMOD | FLTSRC<4:0> | | | | FLTPOL | FLTMOD<1:0> | | 0000 | | | |
| PDC3 | 0466 | PDC3<15:0> | | | | | | | | | | | | | | | | 0000 | |
| PHASE3 | 0468 | PHASE3<15:0> | | | | | | | | | | | | | | | | 0000 | |
| DTR3 | 046C | — | — | DTR3<13:0> | | | | | | | | | | | | 0000 | | | |
| ALTDTR3 | 046C | — | — | ALTDTR3<13:0> | | | | | | | | | | | | 0000 | | | |
| SDC3 | 046E | SDC3<15:0> | | | | | | | | | | | | | | | | 0000 | |
| SPHASE3 | 0470 | SPHASE3<15:0> | | | | | | | | | | | | | | | | 0000 | |
| TRIG3 | 0472 | TRGCMP<15:3> | | | | | | | | | | | | — | — | — | 0000 | | |
| TRGCON3 | 0474 | TRGDIV<3:0> | | | | — | — | — | — | DTM | — | TRGSTRT<5:0> | | | | | 0000 | | |
| STRIG3 | 0476 | STRGCMP<15:3> | | | | | | | | | | | | — | — | — | 0000 | | |
| PWMCAP3 | 0478 | PWMCAP3<15:3> | | | | | | | | | | | | | | | | 0000 | |
| LEBCON3 | 047A | PHR | PHF | PLR | PLF | FLTLEBEN | CLLEBEN | — | — | — | — | BCH | BCL | BPHH | BPHL | BPLH | BPLL | 0000 | |
| LEBDLY3 | 047C | — | — | — | — | LEB<11:3> | | | | | | | | | | — | — | — | 0000 |
| AUXCON3 | 047E | HRPDIS | HRDDIS | — | — | BLANKSEL<3:0> | | | | — | — | CHOPSEL<3:0> | | | | CHOPHEN | CHOPLEN | 0000 | |

Legend: x = unknown value on Reset, — = unimplemented, read as '0'. Reset values are shown in hexadecimal.

TABLE 4-20: HIGH-SPEED PWM GENERATOR 4 REGISTER MAP

| File Name | SFR Addr. | Bit 15 | Bit 14 | Bit 13 | Bit 12 | Bit 11 | Bit 10 | Bit 9 | Bit 8 | Bit 7 | Bit 6 | Bit 5 | Bit 4 | Bit 3 | Bit 2 | Bit 1 | Bit 0 | All Resets | | |
|-----------|-----------|---------------|------------|---------------|----------|---------------|----------|--------|--------|-------------|-------|--------------|-------|------------|--------|-------------|--------|------------|------|------|
| PWMCON4 | 0480 | FLTSTAT | CLSTAT | TRGSTAT | FLTIEIEN | CLIEIEN | TRGIEIEN | ITB | MDCS | DTC<1:0> | | DTCP | — | MTBS | CAM | XPRES | IUE | 0000 | | |
| IOCON4 | 0482 | PENH | PENL | POLH | POLL | PMDIV<1:0> | | OVRENH | OVRENL | OVRDAT<1:0> | | FLTDAT<1:0> | | CLDAT<1:0> | | SWAP | OSYNC | 0000 | | |
| FCLCON4 | 0484 | IFLTMOD | CLSRC<4:0> | | | | | CLPOL | CLMOD | FLTSRC<4:0> | | | | | FLTPOL | FLTMOD<1:0> | | 0000 | | |
| PDC4 | 0486 | PDC4<15:0> | | | | | | | | | | | | | | | | | 0000 | |
| PHASE4 | 0488 | PHASE4<15:0> | | | | | | | | | | | | | | | | | 0000 | |
| DTR4 | 048A | — | — | DTR4<13:0> | | | | | | | | | | | | | | 0000 | | |
| ALTDTR4 | 048A | — | — | ALTDTR4<13:0> | | | | | | | | | | | | | | 0000 | | |
| SDC4 | 048E | SDC4<15:0> | | | | | | | | | | | | | | | | | 0000 | |
| SPHASE4 | 0490 | SPHASE4<15:0> | | | | | | | | | | | | | | | | | 0000 | |
| TRIG4 | 0492 | TRGCMP<15:3> | | | | | | | | | | | | | — | — | — | 0000 | | |
| TRGCON4 | 0494 | TRGDIV<3:0> | | | | — | — | — | — | DTM | — | TRGSTRT<5:0> | | | | | | | 0000 | |
| STRIG4 | 0496 | STRGCMP<15:3> | | | | | | | | | | | | | — | — | — | 0000 | | |
| PWMCAP4 | 0498 | PWMCAP4<15:3> | | | | | | | | | | | | | | | | | 0000 | |
| LEBCON4 | 049A | PHR | PHF | PLR | PLF | FLTLEBEN | CLLEBEN | — | — | — | — | BCH | BCL | BPHH | BPHL | BPLH | BPLL | 0000 | | |
| LEBDLY4 | 049C | — | — | — | — | LEB<11:3> | | | | | | | | | | | — | — | — | 0000 |
| AUXCON4 | 049E | HRPDIS | HRDDIS | — | — | BLANKSEL<3:0> | | | | — | — | CHOPSEL<3:0> | | | | CHOPHEN | CHOPLN | 0000 | | |

Legend: x = unknown value on Reset, — = unimplemented, read as '0'. Reset values are shown in hexadecimal.

TABLE 4-21: HIGH-SPEED PWM GENERATOR 5 REGISTER MAP

| File Name | SFR Addr. | Bit 15 | Bit 14 | Bit 13 | Bit 12 | Bit 11 | Bit 10 | Bit 9 | Bit 8 | Bit 7 | Bit 6 | Bit 5 | Bit 4 | Bit 3 | Bit 2 | Bit 1 | Bit 0 | All Resets | | |
|-----------|-----------|---------------|------------|---------------|--------|---------------|---------|--------|--------|-------------|-------|--------------|-------|------------|--------|-------------|--------|------------|---|------|
| PWMCON5 | 04A0 | FLTSTAT | CLSTAT | TRGSTAT | FLTIEN | CLIEN | TRGIEN | ITB | MDCS | DTC<1:0> | | DTCP | — | MTBS | CAM | XPRES | IUE | 0000 | | |
| IOCON5 | 04A2 | PENH | PENL | POLH | POLL | PMOD<1:0> | | OVRENH | OVRENL | OVRDAT<1:0> | | FLTDAT<1:0> | | CLDAT<1:0> | | SWAP | OSYNC | 0000 | | |
| FCLCON5 | 04A4 | IFLTMOD | CLSRC<4:0> | | | | | CLPOL | CLMOD | FLTSRC<4:0> | | | | | FLTPOL | FLTMOD<1:0> | | 0000 | | |
| PDC5 | 04A6 | PDC5<15:0> | | | | | | | | | | | | | | | | 0000 | | |
| PHASE5 | 04A8 | PHASE5<15:0> | | | | | | | | | | | | | | | | 0000 | | |
| DTR5 | 04AA | — | — | DTR5<13:0> | | | | | | | | | | | | | 0000 | | | |
| ALTDTR5 | 04AA | — | — | ALTDTR5<13:0> | | | | | | | | | | | | | 0000 | | | |
| SDC5 | 04AE | SDC5<15:0> | | | | | | | | | | | | | | | | 0000 | | |
| SPHASE5 | 04B0 | SPHASE5<15:0> | | | | | | | | | | | | | | | | 0000 | | |
| TRIG5 | 04B2 | TRGCMP<15:3> | | | | | | | | | | | | — | — | — | 0000 | | | |
| TRGCON5 | 04B4 | TRGDIV<3:0> | | | | — | — | — | — | DTM | — | TRGSTRT<5:0> | | | | | | 0000 | | |
| STRIG5 | 04B6 | STRGCMP<15:3> | | | | | | | | | | | | — | — | — | 0000 | | | |
| PWMCAP5 | 04B8 | PWMCAP5<15:3> | | | | | | | | | | | | | | | | 0000 | | |
| LEBCON5 | 04BA | PHR | PHF | PLR | PLF | FLTLEBEN | CLLEBEN | — | — | — | — | BCH | BCL | BPHH | BPHL | BPLH | BPLL | 0000 | | |
| LEBDLY5 | 04BC | — | — | — | — | LEB<11:3> | | | | | | | | | | | — | — | — | 0000 |
| AUXCON5 | 04BE | HRPDIS | HRDDIS | — | — | BLANKSEL<3:0> | | | | — | — | CHOPSEL<3:0> | | | | CHOPHEN | CHOPLN | 0000 | | |

Legend: x = unknown value on Reset, — = unimplemented, read as '0'. Reset values are shown in hexadecimal.

TABLE 4-22: HIGH-SPEED PWM GENERATOR 6 REGISTER MAP

| File Name | SFR Addr. | Bit 15 | Bit 14 | Bit 13 | Bit 12 | Bit 11 | Bit 10 | Bit 9 | Bit 8 | Bit 7 | Bit 6 | Bit 5 | Bit 4 | Bit 3 | Bit 2 | Bit 1 | Bit 0 | All Resets | |
|-----------|-----------|---------------|------------|---------------|--------|---------------|---------|--------|-------------|-------------|-------|--------------|--------|-------------|-------|---------|--------|------------|------|
| PWMCON6 | 04C0 | FLTSTAT | CLSTAT | TRGSTAT | FLTIEN | CLIEN | TRGIEN | ITB | MDCS | DTC<1:0> | | DTCP | — | MTBS | CAM | XPRES | IUE | 0000 | |
| IOCON6 | 04C2 | PENH | PENL | POLH | POLL | PMOD<1:0> | | OVRENH | OVRENL | OVRDAT<1:0> | | FLTDAT<1:0> | | CLDAT<1:0> | | SWAP | OSYNC | 0000 | |
| FCLCON6 | 04C4 | IFLTMOD | CLSRC<4:0> | | | | CLPOL | CLMOD | FLTSRC<4:0> | | | | FLTPOL | FLTMOD<1:0> | | 0000 | | | |
| PDC6 | 04C6 | PDC6<15:0> | | | | | | | | | | | | | | | | 0000 | |
| PHASE6 | 04C8 | PHASE6<15:0> | | | | | | | | | | | | | | | | 0000 | |
| DTR6 | 04CA | — | — | DTR6<13:0> | | | | | | | | | | | | | 0000 | | |
| ALTDTR6 | 04CA | — | — | ALTDTR6<13:0> | | | | | | | | | | | | | 0000 | | |
| SDC6 | 04CE | SDC6<15:0> | | | | | | | | | | | | | | | | 0000 | |
| SPHASE6 | 04D0 | SPHASE6<15:0> | | | | | | | | | | | | | | | | 0000 | |
| TRIG6 | 04D2 | TRGCMP<15:3> | | | | | | | | | | | | — | — | — | 0000 | | |
| TRGCON6 | 04D4 | TRGDIV<3:0> | | | | — | — | — | — | DTM | — | TRGSTRT<5:0> | | | | | | 0000 | |
| STRIG6 | 04D6 | STRGCMP<15:3> | | | | | | | | | | | | — | — | — | 0000 | | |
| PWMCAP6 | 04D8 | PWMCAP6<15:3> | | | | | | | | | | | | | | | | 0000 | |
| LEBCON6 | 04DA | PHR | PHF | PLR | PLF | FLTLEBEN | CLLEBEN | — | — | — | — | BCH | BCL | BPHH | BPHL | BPLH | BPLL | 0000 | |
| LEBDLY6 | 04DC | — | — | — | — | LEB<11:3> | | | | | | | | | | — | — | — | 0000 |
| AUXCON6 | 04DE | HRPDIS | HRDDIS | — | — | BLANKSEL<3:0> | | | | — | — | CHOPSEL<3:0> | | | | CHOPHEN | CHOPLN | 0000 | |

Legend: x = unknown value on Reset, — = unimplemented, read as '0'. Reset values are shown in hexadecimal.

TABLE 4-23: HIGH-SPEED PWM GENERATOR 7 REGISTER MAP (EXCLUDES dsPIC33FJ32GS406 AND dsPIC33FJ64GS406 DEVICES)

| File Name | SFR Addr. | Bit 15 | Bit 14 | Bit 13 | Bit 12 | Bit 11 | Bit 10 | Bit 9 | Bit 8 | Bit 7 | Bit 6 | Bit 5 | Bit 4 | Bit 3 | Bit 2 | Bit 1 | Bit 0 | All Resets | |
|-----------|-----------|---------------|------------|---------------|--------|---------------|---------|--------|--------|-------------|-------|--------------|-------|------------|--------|-------------|--------|------------|------|
| PWMCON7 | 04E0 | FLTSTAT | CLSTAT | TRGSTAT | FLTIEN | CLIEN | TRGIEN | ITB | MDCS | DTC<1:0> | | DTCP | — | MTBS | CAM | XPRES | IUE | 0000 | |
| IOCON7 | 04E2 | PENH | PENL | POLH | POLL | PMOD<1:0> | | OVRENH | OVRENL | OVRDAT<1:0> | | FLTDAT<1:0> | | CLDAT<1:0> | | SWAP | OSYNC | 0000 | |
| FCLCON7 | 04E4 | IFLTMOD | CLSRC<4:0> | | | | | CLPOL | CLMOD | FLTSRC<4:0> | | | | | FLTPOL | FLTMOD<1:0> | | 0000 | |
| PDC7 | 04E6 | PDC7<15:0> | | | | | | | | | | | | | | | | 0000 | |
| PHASE7 | 04E8 | PHASE7<15:0> | | | | | | | | | | | | | | | | 0000 | |
| DTR7 | 04EA | — | — | DTR7<13:0> | | | | | | | | | | | | — | | 0000 | |
| ALTDTR7 | 04EA | — | — | ALTDTR7<13:0> | | | | | | | | | | | | — | | 0000 | |
| SDC7 | 04EE | SDC7<15:0> | | | | | | | | | | | | | | | | 0000 | |
| SPHASE7 | 04F0 | SPHASE7<15:0> | | | | | | | | | | | | | | | | 0000 | |
| TRIG7 | 04F2 | TRGCMP<15:3> | | | | | | | | | | | | — | — | — | 0000 | | |
| TRGCON7 | 04F4 | TRGDIV<3:0> | | | | — | — | — | — | DTM | — | TRGSTRT<5:0> | | | | | 0000 | | |
| STRIG7 | 04F6 | STRGCMP<15:3> | | | | | | | | | | | | — | — | — | 0000 | | |
| PWMCAP7 | 04F8 | PWMCAP7<15:3> | | | | | | | | | | | | | | | | 0000 | |
| LEBCON7 | 04FA | PHR | PHF | PLR | PLF | FLTLEBEN | CLLEBEN | — | — | — | — | BCH | BCL | BPHH | BPHL | BPLH | BPLL | 0000 | |
| LEBDLY7 | 04FC | — | — | — | — | LEB<11:3> | | | | | | | | | | — | — | — | 0000 |
| AUXCON7 | 04FE | HRPDIS | HRDDIS | — | — | BLANKSEL<3:0> | | | | — | — | CHOPSEL<3:0> | | | | CHOPHEN | CHOPLN | 0000 | |

Legend: x = unknown value on Reset, — = unimplemented, read as '0'. Reset values are shown in hexadecimal.

TABLE 4-24: HIGH-SPEED PWM GENERATOR 8 REGISTER MAP (EXCLUDES dsPIC33FJ32GS406 AND dsPIC33FJ64GS406 DEVICES)

| File Name | SFR Addr. | Bit 15 | Bit 14 | Bit 13 | Bit 12 | Bit 11 | Bit 10 | Bit 9 | Bit 8 | Bit 7 | Bit 6 | Bit 5 | Bit 4 | Bit 3 | Bit 2 | Bit 1 | Bit 0 | All Resets | |
|-----------|-----------|---------------|------------|---------------|--------|---------------|---------|--------|-------------|-------------|--------------|--------------|--------|-------------|-------|---------|--------|------------|------|
| PWMCON8 | 0500 | FLTSTAT | CLSTAT | TRGSTAT | FLTIEN | CLIEN | TRGIEN | ITB | MDCS | DTC<1:0> | | DTCP | — | MTBS | CAM | XPRES | IUE | 0000 | |
| IOCON8 | 0502 | PENH | PENL | POLH | POLL | PMOD<1:0> | | OVRENH | OVRENL | OVRDAT<1:0> | | FLTDAT<1:0> | | CLDAT<1:0> | | SWAP | OSYNC | 0000 | |
| FCLCON8 | 0504 | IFLTMOD | CLSRC<4:0> | | | | CLPOL | CLMOD | FLTSRC<4:0> | | | | FLTPOL | FLTMOD<1:0> | | 0000 | | | |
| PDC8 | 0506 | PDC8<15:0> | | | | | | | | | | | | | | | | 0000 | |
| PHASE8 | 0508 | PHASE8<15:0> | | | | | | | | | | | | | | | | 0000 | |
| DTR8 | 050A | — | — | DTR8<13:0> | | | | | | | | | | | | | 0000 | | |
| ALTDTR8 | 050A | — | — | ALTDTR8<13:0> | | | | | | | | | | | | | 0000 | | |
| SDC8 | 050E | SDC8<15:0> | | | | | | | | | | | | | | | | 0000 | |
| SPHASE8 | 0510 | SPHASE8<15:0> | | | | | | | | | | | | | | | | 0000 | |
| TRIG8 | 0512 | TRGCMP<15:3> | | | | | | | | | | | | — | — | — | 0000 | | |
| TRGCON8 | 0514 | TRGDIV<3:0> | | | — | — | — | — | DTM | — | TRGSTRT<5:0> | | | | | | | 0000 | |
| STRIG8 | 0516 | STRGCMP<15:3> | | | | | | | | | | | | — | — | — | 0000 | | |
| PWMCAP8 | 0518 | PWMCAP8<15:3> | | | | | | | | | | | | | | | | 0000 | |
| LEBCON8 | 051A | PHR | PHF | PLR | PLF | FLTLEBEN | CLLEBEN | — | — | — | — | BCH | BCL | BPHH | BPHL | BPLH | BPLL | 0000 | |
| LEBDLY8 | 051C | — | — | — | — | LEB<11:3> | | | | | | | | | | — | — | — | 0000 |
| AUXCON8 | 051E | HRPDIS | HRDDIS | — | — | BLANKSEL<3:0> | | | | — | — | CHOPSEL<3:0> | | | | CHOPHEN | CHOPLN | 0000 | |

Legend: x = unknown value on Reset, — = unimplemented, read as '0'. Reset values are shown in hexadecimal.

TABLE 4-25: HIGH-SPEED PWM GENERATOR 9 REGISTER MAP FOR dsPIC33FJ32GS610 AND dsPIC33FJ64GS610 DEVICES

| File Name | SFR Addr. | Bit 15 | Bit 14 | Bit 13 | Bit 12 | Bit 11 | Bit 10 | Bit 9 | Bit 8 | Bit 7 | Bit 6 | Bit 5 | Bit 4 | Bit 3 | Bit 2 | Bit 1 | Bit 0 | All Resets | |
|-----------|-----------|---------------|------------|---------------|--------|---------------|---------|--------|-------------|-------------|--------------|--------------|--------|-------------|---------|--------|-------|------------|------|
| PWMCON9 | 0520 | FLTSTAT | CLSTAT | TRGSTAT | FLTIEN | CLIEN | TRGIEN | ITB | MDCS | DTC<1:0> | | DTCP | — | MTBS | CAM | XPRES | IUE | 0000 | |
| IOCON9 | 0522 | PENH | PENL | POLH | POLL | PMOD<1:0> | | OVRENH | OVRENL | OVRDAT<1:0> | | FLTDAT<1:0> | | CLDAT<1:0> | | SWAP | OSYNC | 0000 | |
| FCLCON9 | 0524 | IFLTMOD | CLSRC<4:0> | | | | CLPOL | CLMOD | FLTSRC<4:0> | | | | FLTPOL | FLTMOD<1:0> | | 0000 | | | |
| PDC9 | 0526 | PDC9<15:0> | | | | | | | | | | | | | | | | 0000 | |
| PHASE9 | 0528 | PHASE9<15:0> | | | | | | | | | | | | | | | | 0000 | |
| DTR9 | 052A | — | — | DTR9<13:0> | | | | | | | | | | | | 0000 | | | |
| ALTDTR9 | 052A | — | — | ALTDTR9<13:0> | | | | | | | | | | | | 0000 | | | |
| SDC9 | 052E | SDC9<15:0> | | | | | | | | | | | | | | | | 0000 | |
| SPHASE9 | 0530 | SPHASE9<15:0> | | | | | | | | | | | | | | | | 0000 | |
| TRIG9 | 0532 | TRGCMP<15:3> | | | | | | | | | | | | — | — | — | 0000 | | |
| TRGCON9 | 0534 | TRGDIV<3:0> | | | — | — | — | — | DTM | — | TRGSTRT<5:0> | | | | | | | 0000 | |
| STRIG9 | 0536 | STRGCMP<15:3> | | | | | | | | | | | | — | — | — | 0000 | | |
| PWMCAP9 | 0538 | PWMCAP9<15:3> | | | | | | | | | | | | | | | | 0000 | |
| LEBCON9 | 053A | PHR | PHF | PLR | PLF | FLTLEBEN | CLLEBEN | — | — | — | BCH | BCL | BPHH | BPHL | BPLH | BPLL | 0000 | | |
| LEBDLY9 | 053C | — | — | — | — | LEB<11:3> | | | | | | | | | | — | — | — | 0000 |
| AUXCON9 | 053E | HRPDIS | HRDDIS | — | — | BLANKSEL<3:0> | | | | — | — | CHOPSEL<3:0> | | | CHOPHEN | CHOPLN | 0000 | | |

Legend: x = unknown value on Reset, — = unimplemented, read as '0'. Reset values are shown in hexadecimal.

TABLE 4-26: I2C1 REGISTER MAP

| File Name | SFR Addr. | Bit 15 | Bit 14 | Bit 13 | Bit 12 | Bit 11 | Bit 10 | Bit 9 | Bit 8 | Bit 7 | Bit 6 | Bit 5 | Bit 4 | Bit 3 | Bit 2 | Bit 1 | Bit 0 | All Resets |
|-----------|-----------|---------|--------|---------|--------|--------|--------|-----------------------|------------------------------|-------------------|-------|-------|-------|-------|-------|-------|-------|------------|
| I2C1RCV | 0200 | — | — | — | — | — | — | — | — | Receive Register | | | | | | | | 0000 |
| I2C1TRN | 0202 | — | — | — | — | — | — | — | — | Transmit Register | | | | | | | | 00FF |
| I2C1BRG | 0204 | — | — | — | — | — | — | — | Baud Rate Generator Register | | | | | | | | 0000 | |
| I2C1CON | 0206 | I2CEN | — | I2CSIDL | SCLREL | IPMIEN | A10M | DISSLW | SMEN | GCEN | STREN | ACKDT | ACKEN | RCEN | PEN | RSEN | SEN | 1000 |
| I2C1STAT | 0208 | ACKSTAT | TRSTAT | — | — | — | BCL | GCSTAT | ADD10 | IWCOL | I2COV | D_A | P | S | R_W | RBF | TBF | 0000 |
| I2C1ADD | 020A | — | — | — | — | — | — | Address Register | | | | | | | | 0000 | | |
| I2C1MSK | 020C | — | — | — | — | — | — | Address Mask Register | | | | | | | | 0000 | | |

Legend: x = unknown value on Reset, — = unimplemented, read as '0'. Reset values are shown in hexadecimal.

TABLE 4-27: I2C2 REGISTER MAP

| File Name | SFR Addr. | Bit 15 | Bit 14 | Bit 13 | Bit 12 | Bit 11 | Bit 10 | Bit 9 | Bit 8 | Bit 7 | Bit 6 | Bit 5 | Bit 4 | Bit 3 | Bit 2 | Bit 1 | Bit 0 | All Resets | |
|-----------|-----------|---------|--------|---------|--------|--------|--------|-----------------------|------------------------------|-------------------|-------|-------|-------|-------|-------|-------|-------|------------|------|
| I2C2RCV | 0210 | — | — | — | — | — | — | — | — | Receive Register | | | | | | | | | 0000 |
| I2C2TRN | 0212 | — | — | — | — | — | — | — | — | Transmit Register | | | | | | | | | 00FF |
| I2C2BRG | 0214 | — | — | — | — | — | — | — | Baud Rate Generator Register | | | | | | | | | 0000 | |
| I2C2CON | 0216 | I2CEN | — | I2CSIDL | SCLREL | IPMIEN | A10M | DISSLW | SMEN | GCEN | STREN | ACKDT | ACKEN | RCEN | PEN | RSEN | SEN | 1000 | |
| I2C2STAT | 0218 | ACKSTAT | TRSTAT | — | — | — | BCL | GCSTAT | ADD10 | IWCOL | I2COV | D_A | P | S | R_W | RBF | TBF | 0000 | |
| I2C2ADD | 021A | — | — | — | — | — | — | Address Register | | | | | | | | | 0000 | | |
| I2C2MSK | 021C | — | — | — | — | — | — | Address Mask Register | | | | | | | | | 0000 | | |

Legend: x = unknown value on Reset, — = unimplemented, read as '0'. Reset values are shown in hexadecimal.

TABLE 4-28: UART1 REGISTER MAP

| File Name | SFR Addr. | Bit 15 | Bit 14 | Bit 13 | Bit 12 | Bit 11 | Bit 10 | Bit 9 | Bit 8 | Bit 7 | Bit 6 | Bit 5 | Bit 4 | Bit 3 | Bit 2 | Bit 1 | Bit 0 | All Resets |
|-----------|-----------|-------------------------------|--------|----------|--------|--------|--------|-------|------------------------|--------------|--------|-------|--------|-------|------------|-------|-------|------------|
| U1MODE | 0220 | UARTEN | — | USIDL | IREN | RTSMD | — | UEN1 | UEN0 | WAKE | LPBACK | ABAUD | URXINV | BRGH | PDSEL<1:0> | STSEL | 0000 | |
| U1STA | 0222 | UTXISEL1 | UTXINV | UTXISEL0 | — | UTXBRK | UTXEN | UTXBF | TRMT | URXISEL<1:0> | | ADDEN | RIDLE | PERR | FERR | OERR | URXDA | 0110 |
| U1TXREG | 0224 | — | — | — | — | — | — | — | UART Transmit Register | | | | | | | | | xxxx |
| U1RXREG | 0226 | — | — | — | — | — | — | — | UART Receive Register | | | | | | | | | 0000 |
| U1BRG | 0228 | Baud Rate Generator Prescaler | | | | | | | | | | | | | | | | 0000 |

Legend: x = unknown value on Reset, — = unimplemented, read as '0'. Reset values are shown in hexadecimal.

TABLE 4-29: UART2 REGISTER MAP

| File Name | SFR Addr. | Bit 15 | Bit 14 | Bit 13 | Bit 12 | Bit 11 | Bit 10 | Bit 9 | Bit 8 | Bit 7 | Bit 6 | Bit 5 | Bit 4 | Bit 3 | Bit 2 | Bit 1 | Bit 0 | All Resets |
|-----------|-----------|-------------------------------|--------|----------|--------|--------|--------|-------|------------------------|--------------|--------|-------|--------|-------|------------|-------|-------|------------|
| U2MODE | 0230 | UARTEN | — | USIDL | IREN | RTSMD | — | UEN1 | UEN0 | WAKE | LPBACK | ABAUD | URXINV | BRGH | PDSEL<1:0> | STSEL | 0000 | |
| U2STA | 0232 | UTXISEL1 | UTXINV | UTXISEL0 | — | UTXBRK | UTXEN | UTXBF | TRMT | URXISEL<1:0> | | ADDEN | RIDLE | PERR | FERR | OERR | URXDA | 0110 |
| U2TXREG | 0234 | — | — | — | — | — | — | — | UART Transmit Register | | | | | | | | | xxxx |
| U2RXREG | 0236 | — | — | — | — | — | — | — | UART Receive Register | | | | | | | | | 0000 |
| U2BRG | 0238 | Baud Rate Generator Prescaler | | | | | | | | | | | | | | | | 0000 |

Legend: x = unknown value on Reset, — = unimplemented, read as '0'. Reset values are shown in hexadecimal.

TABLE 4-30: SPI1 REGISTER MAP

| File Name | SFR Addr. | Bit 15 | Bit 14 | Bit 13 | Bit 12 | Bit 11 | Bit 10 | Bit 9 | Bit 8 | Bit 7 | Bit 6 | Bit 5 | Bit 4 | Bit 3 | Bit 2 | Bit 1 | Bit 0 | All Resets |
|-----------|-----------|---|--------|---------|--------|--------|--------|-------|-------|-------|--------|-------|-----------|-------|-------|-----------|--------|------------|
| SPI1STAT | 0240 | SPIEN | — | SPISIDL | — | — | — | — | — | — | SPIROV | — | — | — | — | SPITBF | SPIRBF | 0000 |
| SPI1CON1 | 0242 | — | — | — | DISSCK | DISSDO | MODE16 | SMP | CKE | SSEN | CKP | MSTEN | SPRE<2:0> | | | PPRE<1:0> | | 0000 |
| SPI1CON2 | 0244 | FRMEN | SPIFSD | FRMPOL | — | — | — | — | — | — | — | — | — | — | — | FRMDLY | — | 0000 |
| SPI1BUF | 0248 | SPI1 Transmit and Receive Buffer Register | | | | | | | | | | | | | | | | 0000 |

Legend: x = unknown value on Reset, — = unimplemented, read as '0'. Reset values are shown in hexadecimal.

TABLE 4-31: SPI2 REGISTER MAP

| File Name | SFR Addr. | Bit 15 | Bit 14 | Bit 13 | Bit 12 | Bit 11 | Bit 10 | Bit 9 | Bit 8 | Bit 7 | Bit 6 | Bit 5 | Bit 4 | Bit 3 | Bit 2 | Bit 1 | Bit 0 | All Resets |
|-----------|-----------|---|--------|---------|--------|--------|--------|-------|-------|-------|--------|-------|-----------|-------|-------|-----------|--------|------------|
| SPI2STAT | 0260 | SPIEN | — | SPISIDL | — | — | — | — | — | — | SPIROV | — | — | — | — | SPITBF | SPIRBF | 0000 |
| SPI2CON1 | 0262 | — | — | — | DISSCK | DISSDO | MODE16 | SMP | CKE | SSEN | CKP | MSTEN | SPRE<2:0> | | | PPRE<1:0> | | 0000 |
| SPI2CON2 | 0264 | FRMEN | SPIFSD | FRMPOL | — | — | — | — | — | — | — | — | — | — | — | FRMDLY | — | 0000 |
| SPI2BUF | 0268 | SPI2 Transmit and Receive Buffer Register | | | | | | | | | | | | | | | | 0000 |

Legend: x = unknown value on Reset, — = unimplemented, read as '0'. Reset values are shown in hexadecimal.

TABLE 4-32: HIGH-SPEED 10-BIT ADC REGISTER MAP FOR dsPIC33FJ32GS610 AND dsPIC33FJ64GS610 DEVICES ONLY

| File Name | SFR Addr. | Bit 15 | Bit 14 | Bit 13 | Bit 12 | Bit 11 | Bit 10 | Bit 9 | Bit 8 | Bit 7 | Bit 6 | Bit 5 | Bit 4 | Bit 3 | Bit 2 | Bit 1 | Bit 0 | All Resets | |
|-----------|-----------|--------------------|--------|---------|---------------|--------|--------|-------|---------|---------|---------|---------------|---------------|--------|-----------|--------|--------|------------|------|
| ADCON | 0300 | ADON | — | ADSIDL | SLOWCLK | — | GSWTRG | — | FORM | EIE | ORDER | SEQSAMP | ASYNCSAMP | — | ADCS<2:0> | | | 0003 | |
| ADPCFG | 0302 | PCFG15 | PCFG14 | PCFG13 | PCFG12 | PCFG11 | PCFG10 | PCFG9 | PCFG8 | PCFG7 | PCFG6 | PCFG5 | PCFG4 | PCFG3 | PCFG2 | PCFG1 | PCFG0 | 0000 | |
| ADPCFG2 | 0304 | — | — | — | — | — | — | — | — | PCFG23 | PCFG22 | PCFG21 | PCFG20 | PCFG19 | PCFG18 | PCFG17 | PCFG16 | 0000 | |
| ADSTAT | 0306 | — | — | — | P12RDY | P11RDY | P10RDY | P9RDY | P8RDY | P7RDY | P6RDY | P5RDY | P4RDY | P3RDY | P2RDY | P1RDY | P0RDY | 0000 | |
| ADBASE | 0308 | ADBASE<15:1> | | | | | | | | | | | | | | | | — | 0000 |
| ADCPC0 | 030A | IRQEN1 | PEND1 | SWTRG1 | TRGSRC1<4:0> | | | | IRQEN0 | PEND0 | SWTRG0 | TRGSRC0<4:0> | | | | 0000 | | | |
| ADCPC1 | 030C | IRQEN3 | PEND3 | SWTRG3 | TRGSRC3<4:0> | | | | IRQEN2 | PEND2 | SWTRG2 | TRGSRC2<4:0> | | | | 0000 | | | |
| ADCPC2 | 030E | IRQEN5 | PEND5 | SWTRG5 | TRGSRC5<4:0> | | | | IRQEN4 | PEND4 | SWTRG4 | TRGSRC4<4:0> | | | | 0000 | | | |
| ADCPC3 | 0310 | IRQEN7 | PEND7 | SWTRG7 | TRGSRC7<4:0> | | | | IRQEN6 | PEND6 | SWTRG6 | TRGSRC6<4:0> | | | | 0000 | | | |
| ADCPC4 | 0312 | IRQEN9 | PEND9 | SWTRG9 | TRGSRC9<4:0> | | | | IRQEN8 | PEND8 | SWTRG8 | TRGSRC8<4:0> | | | | 0000 | | | |
| ADCPC5 | 0314 | IRQEN11 | PEND11 | SWTRG11 | TRGSRC11<4:0> | | | | IRQEN10 | PEND10 | SWTRG10 | TRGSRC10<4:0> | | | | 0000 | | | |
| ADCPC6 | 0316 | — | — | — | — | — | — | — | — | IRQEN12 | PEND12 | SWTRG12 | TRGSRC12<4:0> | | | | 0000 | | |
| ADCBUF0 | 0340 | ADC Data Buffer 0 | | | | | | | | | | | | | | | | xxxx | |
| ADCBUF1 | 0342 | ADC Data Buffer 1 | | | | | | | | | | | | | | | | xxxx | |
| ADCBUF2 | 0344 | ADC Data Buffer 2 | | | | | | | | | | | | | | | | xxxx | |
| ADCBUF3 | 0346 | ADC Data Buffer 3 | | | | | | | | | | | | | | | | xxxx | |
| ADCBUF4 | 0348 | ADC Data Buffer 4 | | | | | | | | | | | | | | | | xxxx | |
| ADCBUF5 | 034A | ADC Data Buffer 5 | | | | | | | | | | | | | | | | xxxx | |
| ADCBUF6 | 034C | ADC Data Buffer 6 | | | | | | | | | | | | | | | | xxxx | |
| ADCBUF7 | 034E | ADC Data Buffer 7 | | | | | | | | | | | | | | | | xxxx | |
| ADCBUF8 | 0350 | ADC Data Buffer 8 | | | | | | | | | | | | | | | | xxxx | |
| ADCBUF9 | 0352 | ADC Data Buffer 9 | | | | | | | | | | | | | | | | xxxx | |
| ADCBUF10 | 0354 | ADC Data Buffer 10 | | | | | | | | | | | | | | | | xxxx | |
| ADCBUF11 | 0356 | ADC Data Buffer 11 | | | | | | | | | | | | | | | | xxxx | |
| ADCBUF12 | 0358 | ADC Data Buffer 12 | | | | | | | | | | | | | | | | xxxx | |
| ADCBUF13 | 035A | ADC Data Buffer 13 | | | | | | | | | | | | | | | | xxxx | |
| ADCBUF14 | 035C | ADC Data Buffer 14 | | | | | | | | | | | | | | | | xxxx | |
| ADCBUF15 | 035E | ADC Data Buffer 15 | | | | | | | | | | | | | | | | xxxx | |
| ADCBUF16 | 0360 | ADC Data Buffer 16 | | | | | | | | | | | | | | | | xxxx | |
| ADCBUF17 | 0362 | ADC Data Buffer 17 | | | | | | | | | | | | | | | | xxxx | |
| ADCBUF18 | 0364 | ADC Data Buffer 18 | | | | | | | | | | | | | | | | xxxx | |
| ADCBUF19 | 0366 | ADC Data Buffer 19 | | | | | | | | | | | | | | | | xxxx | |
| ADCBUF20 | 0368 | ADC Data Buffer 20 | | | | | | | | | | | | | | | | xxxx | |
| ADCBUF21 | 036A | ADC Data Buffer 21 | | | | | | | | | | | | | | | | xxxx | |

Legend: x = unknown value on Reset, — = unimplemented, read as '0'. Reset values are shown in hexadecimal.

TABLE 4-32: HIGH-SPEED 10-BIT ADC REGISTER MAP FOR dsPIC33FJ32GS610 AND dsPIC33FJ64GS610 DEVICES ONLY (CONTINUED)

| File Name | SFR Addr. | Bit 15 | Bit 14 | Bit 13 | Bit 12 | Bit 11 | Bit 10 | Bit 9 | Bit 8 | Bit 7 | Bit 6 | Bit 5 | Bit 4 | Bit 3 | Bit 2 | Bit 1 | Bit 0 | All Resets |
|-----------|-----------|--------------------|--------|--------|--------|--------|--------|-------|-------|-------|-------|-------|-------|-------|-------|-------|-------|------------|
| ADCBUF22 | 036C | ADC Data Buffer 22 | | | | | | | | | | | | | | | | xxxx |
| ADCBUF23 | 036E | ADC Data Buffer 23 | | | | | | | | | | | | | | | | xxxx |
| ADCBUF24 | 0370 | ADC Data Buffer 24 | | | | | | | | | | | | | | | | xxxx |
| ADCBUF25 | 0372 | ADC Data Buffer 25 | | | | | | | | | | | | | | | | xxxx |

Legend: x = unknown value on Reset, — = unimplemented, read as '0'. Reset values are shown in hexadecimal.

TABLE 4-33: HIGH-SPEED 10-BIT ADC REGISTER MAP FOR dsPIC33FJ32GS608 AND dsPIC33FJ64GS608 DEVICES

| File Name | SFR Addr. | Bit 15 | Bit 14 | Bit 13 | Bit 12 | Bit 11 | Bit 10 | Bit 9 | Bit 8 | Bit 7 | Bit 6 | Bit 5 | Bit 4 | Bit 3 | Bit 2 | Bit 1 | Bit 0 | All Resets | |
|-----------|-----------|--------------------|--------|--------|--------------|--------|--------|-------|--------|---------|--------|--------------|---------------|-------|-----------|--------|--------|------------|------|
| ADCON | 0300 | ADON | — | ADSIDL | SLOWCLK | — | GSWTRG | — | FORM | EIE | ORDER | SEQSAMP | ASYNCSAMP | — | ADCS<2:0> | | | 0003 | |
| ADPCFG | 0302 | PCFG15 | PCFG14 | PCFG13 | PCFG12 | PCFG11 | PCFG10 | PCFG9 | PCFG8 | PCFG7 | PCFG6 | PCFG5 | PCFG4 | PCFG3 | PCFG2 | PCFG1 | PCFG0 | 0000 | |
| ADPCFG2 | 0304 | — | — | — | — | — | — | — | — | — | — | — | — | — | — | PCFG17 | PCFG16 | 0000 | |
| ADSTAT | 0306 | — | — | — | P12RDY | — | — | — | P8RDY | P7RDY | P6RDY | P5RDY | P4RDY | P3RDY | P2RDY | P1RDY | P0RDY | 0000 | |
| ADBASE | 0308 | ADBASE<15:1> | | | | | | | | | | | | | | | | — | 0000 |
| ADCPC0 | 030A | IRQEN1 | PEND1 | SWTRG1 | TRGSRC1<4:0> | | | | IRQEN0 | PEND0 | SWTRG0 | TRGSRC0<4:0> | | | | 0000 | | | |
| ADCPC1 | 030C | IRQEN3 | PEND3 | SWTRG3 | TRGSRC3<4:0> | | | | IRQEN2 | PEND2 | SWTRG2 | TRGSRC2<4:0> | | | | 0000 | | | |
| ADCPC2 | 030E | IRQEN5 | PEND5 | SWTRG5 | TRGSRC5<4:0> | | | | IRQEN4 | PEND4 | SWTRG4 | TRGSRC4<4:0> | | | | 0000 | | | |
| ADCPC3 | 0310 | IRQEN7 | PEND7 | SWTRG7 | TRGSRC7<4:0> | | | | IRQEN6 | PEND6 | SWTRG6 | TRGSRC6<4:0> | | | | 0000 | | | |
| ADCPC4 | 0312 | — | — | — | — | — | — | — | — | IRQEN8 | PEND8 | SWTRG8 | TRGSRC8<4:0> | | | | 0000 | | |
| ADCPC6 | 0316 | — | — | — | — | — | — | — | — | IRQEN12 | PEND12 | SWTRG12 | TRGSRC12<4:0> | | | | 0000 | | |
| ADCBUF0 | 0340 | ADC Data Buffer 0 | | | | | | | | | | | | | | | | xxxx | |
| ADCBUF1 | 0342 | ADC Data Buffer 1 | | | | | | | | | | | | | | | | xxxx | |
| ADCBUF2 | 0344 | ADC Data Buffer 2 | | | | | | | | | | | | | | | | xxxx | |
| ADCBUF3 | 0346 | ADC Data Buffer 3 | | | | | | | | | | | | | | | | xxxx | |
| ADCBUF4 | 0348 | ADC Data Buffer 4 | | | | | | | | | | | | | | | | xxxx | |
| ADCBUF5 | 034A | ADC Data Buffer 5 | | | | | | | | | | | | | | | | xxxx | |
| ADCBUF6 | 034C | ADC Data Buffer 6 | | | | | | | | | | | | | | | | xxxx | |
| ADCBUF7 | 034E | ADC Data Buffer 7 | | | | | | | | | | | | | | | | xxxx | |
| ADCBUF8 | 0350 | ADC Data Buffer 8 | | | | | | | | | | | | | | | | xxxx | |
| ADCBUF9 | 0352 | ADC Data Buffer 9 | | | | | | | | | | | | | | | | xxxx | |
| ADCBUF10 | 0354 | ADC Data Buffer 10 | | | | | | | | | | | | | | | | xxxx | |
| ADCBUF11 | 0356 | ADC Data Buffer 11 | | | | | | | | | | | | | | | | xxxx | |
| ADCBUF12 | 0358 | ADC Data Buffer 12 | | | | | | | | | | | | | | | | xxxx | |
| ADCBUF13 | 035A | ADC Data Buffer 13 | | | | | | | | | | | | | | | | xxxx | |
| ADCBUF14 | 035C | ADC Data Buffer 14 | | | | | | | | | | | | | | | | xxxx | |
| ADCBUF15 | 035E | ADC Data Buffer 15 | | | | | | | | | | | | | | | | xxxx | |
| ADCBUF16 | 0360 | ADC Data Buffer 16 | | | | | | | | | | | | | | | | xxxx | |
| ADCBUF17 | 0362 | ADC Data Buffer 17 | | | | | | | | | | | | | | | | xxxx | |
| ADCBUF24 | 0370 | ADC Data Buffer 24 | | | | | | | | | | | | | | | | xxxx | |
| ADCBUF25 | 0372 | ADC Data Buffer 25 | | | | | | | | | | | | | | | | xxxx | |

Legend: x = unknown value on Reset, — = unimplemented, read as '0'. Reset values are shown in hexadecimal.

TABLE 4-34: HIGH-SPEED 10-BIT ADC REGISTER MAP FOR dsPIC33FJ32GS606 AND dsPIC33FJ64GS606 DEVICES

| File Name | SFR Addr. | Bit 15 | Bit 14 | Bit 13 | Bit 12 | Bit 11 | Bit 10 | Bit 9 | Bit 8 | Bit 7 | Bit 6 | Bit 5 | Bit 4 | Bit 3 | Bit 2 | Bit 1 | Bit 0 | All Resets | |
|-----------|-----------|--------------------|--------|--------|--------------|--------|--------|-------|-------|---------|--------|---------|---------------|-------|-----------|-------|-------|------------|------|
| ADCON | 0300 | ADON | — | ADSIDL | SLOWCLK | — | GSWTRG | — | FORM | EIE | ORDER | SEQSAMP | ASYNCSAMP | — | ADCS<2:0> | | | 0003 | |
| ADPCFG | 0302 | PCFG15 | PCFG14 | PCFG13 | PCFG12 | PCFG11 | PCFG10 | PCFG9 | PCFG8 | PCFG7 | PCFG6 | PCFG5 | PCFG4 | PCFG3 | PCFG2 | PCFG1 | PCFG0 | 0000 | |
| ADSTAT | 0306 | — | — | — | P12RDY | — | — | — | — | P7RDY | P6RDY | P5RDY | P4RDY | P3RDY | P2RDY | P1RDY | P0RDY | 0000 | |
| ADBASE | 0308 | ADBASE<15:1> | | | | | | | | | | | | | | | | — | 0000 |
| ADCPC0 | 030A | IRQEN1 | PEND1 | SWTRG1 | TRGSRC1<4:0> | | | | | IRQEN0 | PEND0 | SWTRG0 | TRGSRC0<4:0> | | | | | 0000 | |
| ADCPC1 | 030C | IRQEN3 | PEND3 | SWTRG3 | TRGSRC3<4:0> | | | | | IRQEN2 | PEND2 | SWTRG2 | TRGSRC2<4:0> | | | | | 0000 | |
| ADCPC2 | 030E | IRQEN5 | PEND5 | SWTRG5 | TRGSRC5<4:0> | | | | | IRQEN4 | PEND4 | SWTRG4 | TRGSRC4<4:0> | | | | | 0000 | |
| ADCPC3 | 0310 | IRQEN7 | PEND7 | SWTRG7 | TRGSRC7<4:0> | | | | | IRQEN6 | PEND6 | SWTRG6 | TRGSRC6<4:0> | | | | | 0000 | |
| ADCPC6 | 0316 | — | — | — | — | — | — | — | — | IRQEN12 | PEND12 | SWTRG12 | TRGSRC12<4:0> | | | | | 0000 | |
| ADCBUF0 | 0340 | ADC Data Buffer 0 | | | | | | | | | | | | | | | | xxxx | |
| ADCBUF1 | 0342 | ADC Data Buffer 1 | | | | | | | | | | | | | | | | xxxx | |
| ADCBUF2 | 0344 | ADC Data Buffer 2 | | | | | | | | | | | | | | | | xxxx | |
| ADCBUF3 | 0346 | ADC Data Buffer 3 | | | | | | | | | | | | | | | | xxxx | |
| ADCBUF4 | 0348 | ADC Data Buffer 4 | | | | | | | | | | | | | | | | xxxx | |
| ADCBUF5 | 034A | ADC Data Buffer 5 | | | | | | | | | | | | | | | | xxxx | |
| ADCBUF6 | 034C | ADC Data Buffer 6 | | | | | | | | | | | | | | | | xxxx | |
| ADCBUF7 | 034E | ADC Data Buffer 7 | | | | | | | | | | | | | | | | xxxx | |
| ADCBUF8 | 0350 | ADC Data Buffer 8 | | | | | | | | | | | | | | | | xxxx | |
| ADCBUF9 | 0352 | ADC Data Buffer 9 | | | | | | | | | | | | | | | | xxxx | |
| ADCBUF10 | 0354 | ADC Data Buffer 10 | | | | | | | | | | | | | | | | xxxx | |
| ADCBUF11 | 0356 | ADC Data Buffer 11 | | | | | | | | | | | | | | | | xxxx | |
| ADCBUF12 | 0358 | ADC Data Buffer 12 | | | | | | | | | | | | | | | | xxxx | |
| ADCBUF13 | 035A | ADC Data Buffer 13 | | | | | | | | | | | | | | | | xxxx | |
| ADCBUF14 | 035C | ADC Data Buffer 14 | | | | | | | | | | | | | | | | xxxx | |
| ADCBUF15 | 035E | ADC Data Buffer 15 | | | | | | | | | | | | | | | | xxxx | |
| ADCBUF24 | 0370 | ADC Data Buffer 24 | | | | | | | | | | | | | | | | xxxx | |
| ADCBUF25 | 0372 | ADC Data Buffer 25 | | | | | | | | | | | | | | | | xxxx | |

Legend: x = unknown value on Reset, — = unimplemented, read as '0'. Reset values are shown in hexadecimal.

TABLE 4-35: HIGH-SPEED 10-BIT ADC REGISTER MAP FOR dsPIC33FJ32GS406 AND dsPIC33FJ64GS406 DEVICES

| File Name | SFR Addr. | Bit 15 | Bit 14 | Bit 13 | Bit 12 | Bit 11 | Bit 10 | Bit 9 | Bit 8 | Bit 7 | Bit 6 | Bit 5 | Bit 4 | Bit 3 | Bit 2 | Bit 1 | Bit 0 | All Resets |
|-----------|-----------|--------------------|--------|--------|--------------|--------|--------|-------|--------|-------|--------|--------------|-----------|-------|-----------|-------|-------|------------|
| ADCON | 0300 | ADON | — | ADSIDL | SLOWCLK | — | GSWTRG | — | FORM | EIE | ORDER | SEQSAMP | ASYNCSAMP | — | ADCS<2:0> | | | 0003 |
| ADPCFG | 0302 | PCFG15 | PCFG14 | PCFG13 | PCFG12 | PCFG11 | PCFG10 | PCFG9 | PCFG8 | PCFG7 | PCFG6 | PCFG5 | PCFG4 | PCFG3 | PCFG2 | PCFG1 | PCFG0 | 0000 |
| ADSTAT | 0306 | — | — | — | P12RDY | — | — | — | — | P7RDY | P6RDY | P5RDY | P4RDY | P3RDY | P2RDY | P1RDY | P0RDY | 0000 |
| ADBASE | 0308 | ADBASE<15:1> | | | | | | | | | | | | | | | — | 0000 |
| ADCPC0 | 030A | IRQEN1 | PEND1 | SWTRG1 | TRGSRC1<4:0> | | | | IRQEN0 | PEND0 | SWTRG0 | TRGSRC0<4:0> | | | | 0000 | | |
| ADCPC1 | 030C | IRQEN3 | PEND3 | SWTRG3 | TRGSRC3<4:0> | | | | IRQEN2 | PEND2 | SWTRG2 | TRGSRC2<4:0> | | | | 0000 | | |
| ADCPC2 | 030E | IRQEN5 | PEND5 | SWTRG5 | TRGSRC5<4:0> | | | | IRQEN4 | PEND4 | SWTRG4 | TRGSRC4<4:0> | | | | 0000 | | |
| ADCPC3 | 0310 | IRQEN7 | PEND7 | SWTRG7 | TRGSRC7<4:0> | | | | IRQEN6 | PEND6 | SWTRG6 | TRGSRC6<4:0> | | | | 0000 | | |
| ADCBUF0 | 0340 | ADC Data Buffer 0 | | | | | | | | | | | | | | | xxxx | |
| ADCBUF1 | 0342 | ADC Data Buffer 1 | | | | | | | | | | | | | | | xxxx | |
| ADCBUF2 | 0344 | ADC Data Buffer 2 | | | | | | | | | | | | | | | xxxx | |
| ADCBUF3 | 0346 | ADC Data Buffer 3 | | | | | | | | | | | | | | | xxxx | |
| ADCBUF4 | 0348 | ADC Data Buffer 4 | | | | | | | | | | | | | | | xxxx | |
| ADCBUF5 | 034A | ADC Data Buffer 5 | | | | | | | | | | | | | | | xxxx | |
| ADCBUF6 | 034C | ADC Data Buffer 6 | | | | | | | | | | | | | | | xxxx | |
| ADCBUF7 | 034E | ADC Data Buffer 7 | | | | | | | | | | | | | | | xxxx | |
| ADCBUF8 | 0350 | ADC Data Buffer 8 | | | | | | | | | | | | | | | xxxx | |
| ADCBUF9 | 0352 | ADC Data Buffer 9 | | | | | | | | | | | | | | | xxxx | |
| ADCBUF10 | 0354 | ADC Data Buffer 10 | | | | | | | | | | | | | | | xxxx | |
| ADCBUF11 | 0356 | ADC Data Buffer 11 | | | | | | | | | | | | | | | xxxx | |
| ADCBUF12 | 0358 | ADC Data Buffer 12 | | | | | | | | | | | | | | | xxxx | |
| ADCBUF13 | 035A | ADC Data Buffer 13 | | | | | | | | | | | | | | | xxxx | |
| ADCBUF14 | 035C | ADC Data Buffer 14 | | | | | | | | | | | | | | | xxxx | |
| ADCBUF15 | 035E | ADC Data Buffer 15 | | | | | | | | | | | | | | | xxxx | |

Legend: x = unknown value on Reset, — = unimplemented, read as '0'. Reset values are shown in hexadecimal.

TABLE 4-36: DMA REGISTER MAP

| File Name | SFR Addr. | Bit 15 | Bit 14 | Bit 13 | Bit 12 | Bit 11 | Bit 10 | Bit 9 | Bit 8 | Bit 7 | Bit 6 | Bit 5 | Bit 4 | Bit 3 | Bit 2 | Bit 1 | Bit 0 | All Resets |
|-----------|-----------|-------------|--------|--------|--------|------------|--------|----------|--------|-------|-------------|------------|-------|--------|--------|-----------|--------|------------|
| DMA0CON | 0380 | CHEN | SIZE | DIR | HALF | NULLW | — | — | — | — | — | AMODE<1:0> | | — | — | MODE<1:0> | | 0000 |
| DMA0REQ | 0382 | FORCE | — | — | — | — | — | — | — | — | IRQSEL<6:0> | | | | | | | 007F |
| DMA0STA | 0384 | STA<15:0> | | | | | | | | | | | | | | | | 0000 |
| DMA0STB | 0386 | STB<15:0> | | | | | | | | | | | | | | | | 0000 |
| DMA0PAD | 0388 | PAD<15:0> | | | | | | | | | | | | | | | | 0000 |
| DMA0CNT | 038A | — | — | — | — | — | — | CNT<9:0> | | | | | | | | | | 0000 |
| DMA1CON | 038C | CHEN | SIZE | DIR | HALF | NULLW | — | — | — | — | — | AMODE<1:0> | | — | — | MODE<1:0> | | 0000 |
| DMA1REQ | 038E | FORCE | — | — | — | — | — | — | — | — | IRQSEL<6:0> | | | | | | | 007F |
| DMA1STA | 0390 | STA<15:0> | | | | | | | | | | | | | | | | 0000 |
| DMA1STB | 0392 | STB<15:0> | | | | | | | | | | | | | | | | 0000 |
| DMA1PAD | 0394 | PAD<15:0> | | | | | | | | | | | | | | | | 0000 |
| DMA1CNT | 0396 | — | — | — | — | — | — | CNT<9:0> | | | | | | | | | | 0000 |
| DMA2CON | 0398 | CHEN | SIZE | DIR | HALF | NULLW | — | — | — | — | — | AMODE<1:0> | | — | — | MODE<1:0> | | 0000 |
| DMA2REQ | 039A | FORCE | — | — | — | — | — | — | — | — | IRQSEL<6:0> | | | | | | | 007F |
| DMA2STA | 039C | STA<15:0> | | | | | | | | | | | | | | | | 0000 |
| DMA2STB | 039E | STB<15:0> | | | | | | | | | | | | | | | | 0000 |
| DMA2PAD | 03A0 | PAD<15:0> | | | | | | | | | | | | | | | | 0000 |
| DMA2CNT | 03A2 | — | — | — | — | — | — | CNT<9:0> | | | | | | | | | | 0000 |
| DMA3CON | 03A4 | CHEN | SIZE | DIR | HALF | NULLW | — | — | — | — | — | AMODE<1:0> | | — | — | MODE<1:0> | | 0000 |
| DMA3REQ | 03A6 | FORCE | — | — | — | — | — | — | — | — | IRQSEL<6:0> | | | | | | | 007F |
| DMA3STA | 03A8 | STA<15:0> | | | | | | | | | | | | | | | | 0000 |
| DMA3STB | 03AA | STB<15:0> | | | | | | | | | | | | | | | | 0000 |
| DMA3PAD | 03AC | PAD<15:0> | | | | | | | | | | | | | | | | 0000 |
| DMA3CNT | 03AE | — | — | — | — | — | — | CNT<9:0> | | | | | | | | | | 0000 |
| DMACS0 | 03E0 | — | — | — | — | PWCOL3 | PWCOL2 | PWCOL1 | PWCOL0 | — | — | — | — | XWCOL3 | XWCOL2 | XWCOL1 | XWCOL0 | 0000 |
| DMACS1 | 03E2 | — | — | — | — | LSTCH<3:0> | | | | — | — | — | — | PPST3 | PPST2 | PPST1 | PPST0 | 0F00 |
| DSADR | 03E4 | DSADR<15:0> | | | | | | | | | | | | | | | | 0000 |

Legend: x = unknown value on Reset, — = unimplemented, read as '0'. Reset values are shown in hexadecimal.

TABLE 4-37: ECAN1 REGISTER MAP WHEN WIN (C1CTRL1<0>) = 0 OR 1

| File Name | SFR Addr. | Bit 15 | Bit 14 | Bit 13 | Bit 12 | Bit 11 | Bit 10 | Bit 9 | Bit 8 | Bit 7 | Bit 6 | Bit 5 | Bit 4 | Bit 3 | Bit 2 | Bit 1 | Bit 0 | All Resets |
|------------|-----------|--------------|---------|-------------|-------------|-------------|--------------|-------------|--------|-------------|------------|-------------|------------|------------|------------|------------|--------|------------|
| C1CTRL1 | 0600 | — | — | CSIDL | ABAT | — | REQOP<2:0> | | | OPMODE<2:0> | | | — | CANCAP | — | — | WIN | 0480 |
| C1CTRL2 | 0602 | — | — | — | — | — | — | — | — | — | — | — | DNCNT<4:0> | | | | | 0000 |
| C1VEC | 0604 | — | — | — | FILHIT<4:0> | | | | | — | ICODE<6:0> | | | | | 0000 | | |
| C1FCTRL | 0606 | DMABS<2:0> | | | — | — | — | — | — | — | — | — | FSA<4:0> | | | | | 0000 |
| C1FIFO | 0608 | — | — | FBP<5:0> | | | | | — | — | FNRB<5:0> | | | | | 0000 | | |
| C1INTF | 060A | — | — | TXBO | TXBP | RXBP | TXWAR | RXWAR | EWARN | IVRIF | WAKIF | ERRIF | — | FIFOIF | RBOVIF | RBIF | TBIF | 0000 |
| C1INTE | 060C | — | — | — | — | — | — | — | — | IVRIE | WAKIE | ERRIE | — | FIFOIE | RBOVIE | RBIE | TBIE | 0000 |
| C1EC | 060E | TERRCNT<7:0> | | | | | RERRCNT<7:0> | | | | | | | | | | 0000 | |
| C1CFG1 | 0610 | — | — | — | — | — | — | — | — | SJW<1:0> | | BRP<5:0> | | | | | 0000 | |
| C1CFG2 | 0612 | — | WAKFIL | — | — | — | SEG2PH<2:0> | | | SEG2PHTS | SAM | SEG1PH<2:0> | | | PRSEG<2:0> | | 0000 | |
| C1FEN1 | 0614 | FLTEN15 | FLTEN14 | FLTEN13 | FLTEN12 | FLTEN11 | FLTEN10 | FLTEN9 | FLTEN8 | FLTEN7 | FLTEN6 | FLTEN5 | FLTEN4 | FLTEN3 | FLTEN2 | FLTEN1 | FLTEN0 | FFFF |
| C1FMSKSEL1 | 0618 | F7MSK<1:0> | | F6MSK<1:0> | | F5MSK<1:0> | | F4MSK<1:0> | | F3MSK<1:0> | | F2MSK<1:0> | | F1MSK<1:0> | | F0MSK<1:0> | | 0000 |
| C1FMSKSEL2 | 061A | F15MSK<1:0> | | F14MSK<1:0> | | F13MSK<1:0> | | F12MSK<1:0> | | F11MSK<1:0> | | F10MSK<1:0> | | F9MSK<1:0> | | F8MSK<1:0> | | 0000 |

Legend: x = unknown value on Reset, — = unimplemented, read as '0'. Reset values are shown in hexadecimal.

TABLE 4-38: ECAN1 REGISTER MAP WHEN WIN (C1CTRL1<0>) = 0

| File Name | SFR Addr. | Bit 15 | Bit 14 | Bit 13 | Bit 12 | Bit 11 | Bit 10 | Bit 9 | Bit 8 | Bit 7 | Bit 6 | Bit 5 | Bit 4 | Bit 3 | Bit 2 | Bit 1 | Bit 0 | All Resets | |
|-----------|-----------|-----------------------------|---------|---------|---------|---------|---------|-------------|---------|---------|---------|---------|---------|---------|---------|-------------|---------|------------|------|
| | 0600-061E | See definition when WIN = x | | | | | | | | | | | | | | | | | |
| C1RXFUL1 | 0620 | RXFUL15 | RXFUL14 | RXFUL13 | RXFUL12 | RXFUL11 | RXFUL10 | RXFUL9 | RXFUL8 | RXFUL7 | RXFUL6 | RXFUL5 | RXFUL4 | RXFUL3 | RXFUL2 | RXFUL1 | RXFUL0 | 0000 | |
| C1RXFUL2 | 0622 | RXFUL31 | RXFUL30 | RXFUL29 | RXFUL28 | RXFUL27 | RXFUL26 | RXFUL25 | RXFUL24 | RXFUL23 | RXFUL22 | RXFUL21 | RXFUL20 | RXFUL19 | RXFUL18 | RXFUL17 | RXFUL16 | 0000 | |
| C1RXOVF1 | 0628 | RXOVF15 | RXOVF14 | RXOVF13 | RXOVF12 | RXOVF11 | RXOVF10 | RXOVF9 | RXOVF8 | RXOVF7 | RXOVF6 | RXOVF5 | RXOVF4 | RXOVF3 | RXOVF2 | RXOVF1 | RXOVF0 | 0000 | |
| C1RXOVF2 | 062A | RXOVF31 | RXOVF30 | RXOVF29 | RXOVF28 | RXOVF27 | RXOVF26 | RXOVF25 | RXOVF24 | RXOVF23 | RXOVF22 | RXOVF21 | RXOVF20 | RXOVF19 | RXOVF18 | RXOVF17 | RXOVF16 | 0000 | |
| C1TR01CON | 0630 | TXEN1 | TXABT1 | TXLARB1 | TXERR1 | TXREQ1 | RTREN1 | TX1PRI<1:0> | | TXEN0 | TXABT0 | TXLARB0 | TXERR0 | TXREQ0 | RTREN0 | TX0PRI<1:0> | | 0000 | |
| C1TR23CON | 0632 | TXEN3 | TXABT3 | TXLARB3 | TXERR3 | TXREQ3 | RTREN3 | TX3PRI<1:0> | | TXEN2 | TXABT2 | TXLARB2 | TXERR2 | TXREQ2 | RTREN2 | TX2PRI<1:0> | | 0000 | |
| C1TR45CON | 0634 | TXEN5 | TXABT5 | TXLARB5 | TXERR5 | TXREQ5 | RTREN5 | TX5PRI<1:0> | | TXEN4 | TXABT4 | TXLARB4 | TXERR4 | TXREQ4 | RTREN4 | TX4PRI<1:0> | | 0000 | |
| C1TR67CON | 0636 | TXEN7 | TXABT7 | TXLARB7 | TXERR7 | TXREQ7 | RTREN7 | TX7PRI<1:0> | | TXEN6 | TXABT6 | TXLARB6 | TXERR6 | TXREQ6 | RTREN6 | TX6PRI<1:0> | | 0000 | |
| C1RXD | 0640 | Received Data Word | | | | | | | | | | | | | | | | | xxxx |
| C1TXD | 0642 | Transmit Data Word | | | | | | | | | | | | | | | | | xxxx |

Legend: x = unknown value on Reset, — = unimplemented, read as '0'. Reset values are shown in hexadecimal.

TABLE 4-39: ECAN1 REGISTER MAP WHEN WIN (C1CTRL1<0>) = 1

| File Name | SFR Addr. | Bit 15 | Bit 14 | Bit 13 | Bit 12 | Bit 11 | Bit 10 | Bit 9 | Bit 8 | Bit 7 | Bit 6 | Bit 5 | Bit 4 | Bit 3 | Bit 2 | Bit 1 | Bit 0 | All Resets |
|------------|-----------|-----------------------------|--------|--------|--------|------------|--------|----------|-------|------------|-------|-------|-------|------------|-------|-------|------------|------------|
| | 0600-061E | See definition when WIN = x | | | | | | | | | | | | | | | | |
| C1BUFNT1 | 0620 | F3BP<3:0> | | | | F2BP<3:0> | | | | F1BP<3:0> | | | | F0BP<3:0> | | | | 0000 |
| C1BUFNT2 | 0622 | F7BP<3:0> | | | | F6BP<3:0> | | | | F5BP<3:0> | | | | F4BP<3:0> | | | | 0000 |
| C1BUFNT3 | 0624 | F11BP<3:0> | | | | F10BP<3:0> | | | | F9BP<3:0> | | | | F8BP<3:0> | | | | 0000 |
| C1BUFNT4 | 0626 | F15BP<3:0> | | | | F14BP<3:0> | | | | F13BP<3:0> | | | | F12BP<3:0> | | | | 0000 |
| C1RXM0SID | 0630 | SID<10:3> | | | | | | SID<2:0> | | | | | | — | MIDE | — | EID<17:16> | xxxx |
| C1RXM0EID | 0632 | EID<15:8> | | | | | | EID<7:0> | | | | | | | | | | xxxx |
| C1RXM1SID | 0634 | SID<10:3> | | | | | | SID<2:0> | | | | | | — | MIDE | — | EID<17:16> | xxxx |
| C1RXM1EID | 0636 | EID<15:8> | | | | | | EID<7:0> | | | | | | | | | | xxxx |
| C1RXM2SID | 0638 | SID<10:3> | | | | | | SID<2:0> | | | | | | — | MIDE | — | EID<17:16> | xxxx |
| C1RXM2EID | 063A | EID<15:8> | | | | | | EID<7:0> | | | | | | | | | | xxxx |
| C1RXF0SID | 0640 | SID<10:3> | | | | | | SID<2:0> | | | | | | — | EXIDE | — | EID<17:16> | xxxx |
| C1RXF0EID | 0642 | EID<15:8> | | | | | | EID<7:0> | | | | | | | | | | xxxx |
| C1RXF1SID | 0644 | SID<10:3> | | | | | | SID<2:0> | | | | | | — | EXIDE | — | EID<17:16> | xxxx |
| C1RXF1EID | 0646 | EID<15:8> | | | | | | EID<7:0> | | | | | | | | | | xxxx |
| C1RXF2SID | 0648 | SID<10:3> | | | | | | SID<2:0> | | | | | | — | EXIDE | — | EID<17:16> | xxxx |
| C1RXF2EID | 064A | EID<15:8> | | | | | | EID<7:0> | | | | | | | | | | xxxx |
| C1RXF3SID | 064C | SID<10:3> | | | | | | SID<2:0> | | | | | | — | EXIDE | — | EID<17:16> | xxxx |
| C1RXF3EID | 064E | EID<15:8> | | | | | | EID<7:0> | | | | | | | | | | xxxx |
| C1RXF4SID | 0650 | SID<10:3> | | | | | | SID<2:0> | | | | | | — | EXIDE | — | EID<17:16> | xxxx |
| C1RXF4EID | 0652 | EID<15:8> | | | | | | EID<7:0> | | | | | | | | | | xxxx |
| C1RXF5SID | 0654 | SID<10:3> | | | | | | SID<2:0> | | | | | | — | EXIDE | — | EID<17:16> | xxxx |
| C1RXF5EID | 0656 | EID<15:8> | | | | | | EID<7:0> | | | | | | | | | | xxxx |
| C1RXF6SID | 0658 | SID<10:3> | | | | | | SID<2:0> | | | | | | — | EXIDE | — | EID<17:16> | xxxx |
| C1RXF6EID | 065A | EID<15:8> | | | | | | EID<7:0> | | | | | | | | | | xxxx |
| C1RXF7SID | 065C | SID<10:3> | | | | | | SID<2:0> | | | | | | — | EXIDE | — | EID<17:16> | xxxx |
| C1RXF7EID | 065E | EID<15:8> | | | | | | EID<7:0> | | | | | | | | | | xxxx |
| C1RXF8SID | 0660 | SID<10:3> | | | | | | SID<2:0> | | | | | | — | EXIDE | — | EID<17:16> | xxxx |
| C1RXF8EID | 0662 | EID<15:8> | | | | | | EID<7:0> | | | | | | | | | | xxxx |
| C1RXF9SID | 0664 | SID<10:3> | | | | | | SID<2:0> | | | | | | — | EXIDE | — | EID<17:16> | xxxx |
| C1RXF9EID | 0666 | EID<15:8> | | | | | | EID<7:0> | | | | | | | | | | xxxx |
| C1RXF10SID | 0668 | SID<10:3> | | | | | | SID<2:0> | | | | | | — | EXIDE | — | EID<17:16> | xxxx |
| C1RXF10EID | 066A | EID<15:8> | | | | | | EID<7:0> | | | | | | | | | | xxxx |
| C1RXF11SID | 066C | SID<10:3> | | | | | | SID<2:0> | | | | | | — | EXIDE | — | EID<17:16> | xxxx |

Legend: x = unknown value on Reset, — = unimplemented, read as '0'. Reset values are shown in hexadecimal.

TABLE 4-39: ECAN1 REGISTER MAP WHEN WIN (C1CTRL1<0>) = 1 (CONTINUED)

| File Name | SFR Addr. | Bit 15 | Bit 14 | Bit 13 | Bit 12 | Bit 11 | Bit 10 | Bit 9 | Bit 8 | Bit 7 | Bit 6 | Bit 5 | Bit 4 | Bit 3 | Bit 2 | Bit 1 | Bit 0 | All Resets |
|------------|-----------|-----------|--------|--------|--------|--------|--------|-------|-------|----------|-------|-------|-------|-------|------------|-------|-------|------------|
| C1RXF11EID | 066E | EID<15:8> | | | | | | | | EID<7:0> | | | | | | | | xxxx |
| C1RXF12SID | 0670 | SID<10:3> | | | | | | | | SID<2:0> | | — | EXIDE | — | EID<17:16> | | | xxxx |
| C1RXF12EID | 0672 | EID<15:8> | | | | | | | | EID<7:0> | | | | | | | | xxxx |
| C1RXF13SID | 0674 | SID<10:3> | | | | | | | | SID<2:0> | | — | EXIDE | — | EID<17:16> | | | xxxx |
| C1RXF13EID | 0676 | EID<15:8> | | | | | | | | EID<7:0> | | | | | | | | xxxx |
| C1RXF14SID | 0678 | SID<10:3> | | | | | | | | SID<2:0> | | — | EXIDE | — | EID<17:16> | | | xxxx |
| C1RXF14EID | 067A | EID<15:8> | | | | | | | | EID<7:0> | | | | | | | | xxxx |
| C1RXF15SID | 067C | SID<10:3> | | | | | | | | SID<2:0> | | — | EXIDE | — | EID<17:16> | | | xxxx |
| C1RXF15EID | 067E | EID<15:8> | | | | | | | | EID<7:0> | | | | | | | | xxxx |

Legend: x = unknown value on Reset, — = unimplemented, read as '0'. Reset values are shown in hexadecimal.

TABLE 4-40: ANALOG COMPARATOR CONTROL REGISTER MAP

| File Name | SFR Addr. | Bit 15 | Bit 14 | Bit 13 | Bit 12 | Bit 11 | Bit 10 | Bit 9 | Bit 8 | Bit 7 | Bit 6 | Bit 5 | Bit 4 | Bit 3 | Bit 2 | Bit 1 | Bit 0 | All Resets |
|-----------|-----------|--------|--------|---------|--------|--------|--------|------------|-------|------------|--------|-------|---------|-------|--------|-------|-------|------------|
| CMPCON1 | 0540 | CMPON | — | CMPSIDL | — | — | — | — | DACOE | INSEL<1:0> | EXTREF | — | CMPSTAT | — | CMPPOL | RANGE | 0000 | |
| CMPDAC1 | 0542 | — | — | - | — | — | — | CMREF<9:0> | | | | | | | | | 0000 | |
| CMPCON2 | 0544 | CMPON | — | CMPSIDL | — | — | — | — | DACOE | INSEL<1:0> | EXTREF | — | CMPSTAT | — | CMPPOL | RANGE | 0000 | |
| CMPDAC2 | 0546 | — | — | - | — | — | — | CMREF<9:0> | | | | | | | | | 0000 | |
| CMPCON3 | 0548 | CMPON | — | CMPSIDL | — | — | — | — | DACOE | INSEL<1:0> | EXTREF | — | CMPSTAT | — | CMPPOL | RANGE | 0000 | |
| CMPDAC3 | 054A | — | — | - | — | — | — | CMREF<9:0> | | | | | | | | | 0000 | |
| CMPCON4 | 054C | CMPON | — | CMPSIDL | — | — | — | — | DACOE | INSEL<1:0> | EXTREF | — | CMPSTAT | — | CMPPOL | RANGE | 0000 | |
| CMPDAC4 | 054E | — | — | — | — | — | — | CMREF<9:0> | | | | | | | | | 0000 | |

Legend: x = unknown value on Reset, — = unimplemented, read as '0'. Reset values are shown in hexadecimal.

TABLE 4-41: PORTA REGISTER MAP FOR dsPIC33FJ32GS610 AND dsPIC33FJ64GS610 DEVICES

| File Name | SFR Addr. | Bit 15 | Bit 14 | Bit 13 | Bit 12 | Bit 11 | Bit 10 | Bit 9 | Bit 8 | Bit 7 | Bit 6 | Bit 5 | Bit 4 | Bit 3 | Bit 2 | Bit 1 | Bit 0 | All Resets |
|-----------|-----------|---------|---------|--------|--------|--------|---------|--------|-------|--------|--------|--------|--------|--------|--------|--------|--------|------------|
| TRISA | 02C0 | TRISA15 | TRISA14 | — | — | — | TRISA10 | TRISA9 | — | TRISA7 | TRISA6 | TRISA5 | TRISA4 | TRISA3 | TRISA2 | TRISA1 | TRISA0 | C6FF |
| PORTA | 02C2 | RA15 | RA14 | — | — | — | RA10 | RA9 | — | RA7 | RA6 | RA5 | RA4 | RA3 | RA2 | RA1 | RA0 | xxxx |
| LATA | 02C4 | LATA15 | LATA14 | — | — | — | LATA10 | LATA9 | — | LATA7 | LATA6 | LATA5 | LATA4 | LATA3 | LATA2 | LATA1 | LATA0 | 0000 |
| ODCA | 02C6 | ODCA15 | ODCA14 | — | — | — | ODCA10 | ODCA9 | — | — | — | ODCA5 | ODCA4 | — | — | ODCA1 | ODCA0 | 0000 |

Legend: x = unknown value on Reset, — = unimplemented, read as '0'. Reset values are shown in hexadecimal.

TABLE 4-42: PORTA REGISTER MAP FOR dsPIC33FJ32GS608 AND dsPIC33FJ64GS608 DEVICES

| File Name | SFR Addr. | Bit 15 | Bit 14 | Bit 13 | Bit 12 | Bit 11 | Bit 10 | Bit 9 | Bit 8 | Bit 7 | Bit 6 | Bit 5 | Bit 4 | Bit 3 | Bit 2 | Bit 1 | Bit 0 | All Resets |
|-----------|-----------|---------|---------|--------|--------|--------|---------|--------|-------|-------|-------|-------|-------|-------|-------|-------|-------|------------|
| TRISA | 02C0 | TRISA15 | TRISA14 | — | — | — | TRISA10 | TRISA9 | — | — | — | — | — | — | — | — | — | C600 |
| PORTA | 02C2 | RA15 | RA14 | — | — | — | RA10 | RA9 | — | — | — | — | — | — | — | — | — | xxxx |
| LATA | 02C4 | LATA15 | LATA14 | — | — | — | LATA10 | LATA9 | — | — | — | — | — | — | — | — | — | 0000 |
| ODCA | 02C6 | ODCA15 | ODCA14 | — | — | — | ODCA10 | ODCA9 | — | — | — | — | — | — | — | — | — | 0000 |

Legend: x = unknown value on Reset, — = unimplemented, read as '0'. Reset values are shown in hexadecimal.

TABLE 4-43: PORTB REGISTER MAP

| File Name | SFR Addr. | Bit 15 | Bit 14 | Bit 13 | Bit 12 | Bit 11 | Bit 10 | Bit 9 | Bit 8 | Bit 7 | Bit 6 | Bit 5 | Bit 4 | Bit 3 | Bit 2 | Bit 1 | Bit 0 | All Resets |
|-----------|-----------|---------|---------|---------|---------|---------|---------|--------|--------|--------|--------|--------|--------|--------|--------|--------|--------|------------|
| TRISB | 02C8 | TRISB15 | TRISB14 | TRISB13 | TRISB12 | TRISB11 | TRISB10 | TRISB9 | TRISB8 | TRISB7 | TRISB6 | TRISB5 | TRISB4 | TRISB3 | TRISB2 | TRISB1 | TRISB0 | FFFF |
| PORTB | 02CA | RB15 | RB14 | RB13 | RB12 | RB11 | RB10 | RB9 | RB8 | RB7 | RB6 | RB5 | RB4 | RB3 | RB2 | RB1 | RB0 | xxxx |
| LATB | 02CC | LATB15 | LATB14 | LATB13 | LATB12 | LATB11 | LATB10 | LATB9 | LATB8 | LATB7 | LATB6 | LATB5 | LATB4 | LATB3 | LATB2 | LATB1 | LATB0 | 0000 |

Legend: x = unknown value on Reset, — = unimplemented, read as '0'. Reset values are shown in hexadecimal.

TABLE 4-44: PORTC REGISTER MAP FOR dsPIC33FJ32GS610 AND dsPIC33FJ64GS610 DEVICES

| File Name | SFR Addr. | Bit 15 | Bit 14 | Bit 13 | Bit 12 | Bit 11 | Bit 10 | Bit 9 | Bit 8 | Bit 7 | Bit 6 | Bit 5 | Bit 4 | Bit 3 | Bit 2 | Bit 1 | Bit 0 | All Resets |
|-----------|-----------|---------|---------|---------|---------|--------|--------|-------|-------|-------|-------|-------|--------|--------|--------|--------|-------|------------|
| TRISC | 02D0 | TRISC15 | TRISC14 | TRISC13 | TRISC12 | — | — | — | — | — | — | — | TRISC4 | TRISC3 | TRISC2 | TRISC1 | — | F01E |
| PORTC | 02D2 | RC15 | RC14 | RC13 | RC12 | — | — | — | — | — | — | — | RC4 | RC3 | RC2 | RC1 | — | xxxx |
| LATC | 02D4 | LATC15 | LATC14 | LATC13 | LATC12 | — | — | — | — | — | — | — | LATC4 | LATC3 | LATC2 | LATC1 | — | 0000 |

Legend: x = unknown value on Reset, — = unimplemented, read as '0'. Reset values are shown in hexadecimal.

TABLE 4-45: PORTC REGISTER MAP FOR dsPIC33FJ32GS608 AND dsPIC33FJ64GS608 DEVICES

| File Name | SFR Addr. | Bit 15 | Bit 14 | Bit 13 | Bit 12 | Bit 11 | Bit 10 | Bit 9 | Bit 8 | Bit 7 | Bit 6 | Bit 5 | Bit 4 | Bit 3 | Bit 2 | Bit 1 | Bit 0 | All Resets |
|-----------|-----------|---------|---------|---------|---------|--------|--------|-------|-------|-------|-------|-------|-------|-------|--------|--------|-------|------------|
| TRISC | 02D0 | TRISC15 | TRISC14 | TRISC13 | TRISC12 | — | — | — | — | — | — | — | — | — | TRISC2 | TRISC1 | — | F006 |
| PORTC | 02D2 | RC15 | RC14 | RC13 | RC12 | — | — | — | — | — | — | — | — | — | RC2 | RC1 | — | xxxx |
| LATC | 02D4 | LATC15 | LATC14 | LATC13 | LATC12 | — | — | — | — | — | — | — | — | — | LATC2 | LATC1 | — | 0000 |

Legend: x = unknown value on Reset, — = unimplemented, read as '0'. Reset values are shown in hexadecimal.

TABLE 4-46: PORTC REGISTER MAP FOR dsPIC33FJ32GS406/606 AND dsPIC33FJ64GS406/606 DEVICES

| File Name | SFR Addr. | Bit 15 | Bit 14 | Bit 13 | Bit 12 | Bit 11 | Bit 10 | Bit 9 | Bit 8 | Bit 7 | Bit 6 | Bit 5 | Bit 4 | Bit 3 | Bit 2 | Bit 1 | Bit 0 | All Resets |
|-----------|-----------|---------|---------|---------|---------|--------|--------|-------|-------|-------|-------|-------|-------|-------|-------|-------|-------|------------|
| TRISC | 02D0 | TRISC15 | TRISC14 | TRISC13 | TRISC12 | — | — | — | — | — | — | — | — | — | — | — | — | F000 |
| PORTC | 02D2 | RC15 | RC14 | RC13 | RC12 | — | — | — | — | — | — | — | — | — | — | — | — | xxxx |
| LATC | 02D4 | LATC15 | LATC14 | LATC13 | LATC12 | — | — | — | — | — | — | — | — | — | — | — | — | 0000 |

Legend: x = unknown value on Reset, — = unimplemented, read as '0'. Reset values are shown in hexadecimal.

TABLE 4-47: PORTD REGISTER MAP FOR dsPIC33FJ32GS608/610 AND dsPIC33FJ64GS608/610 DEVICES

| File Name | SFR Addr. | Bit 15 | Bit 14 | Bit 13 | Bit 12 | Bit 11 | Bit 10 | Bit 9 | Bit 8 | Bit 7 | Bit 6 | Bit 5 | Bit 4 | Bit 3 | Bit 2 | Bit 1 | Bit 0 | All Resets |
|-----------|-----------|---------|---------|---------|---------|---------|---------|--------|--------|--------|--------|--------|--------|--------|--------|--------|--------|------------|
| TRISD | 02D8 | TRISD15 | TRISD14 | TRISD13 | TRISD12 | TRISD11 | TRISD10 | TRISD9 | TRISD8 | TRISD7 | TRISD6 | TRISD5 | TRISD4 | TRISD3 | TRISD2 | TRISD1 | TRISD0 | FFFF |
| PORTD | 02DA | RD15 | RD14 | RD13 | RD12 | RD11 | RD10 | RD9 | RD8 | RD7 | RD6 | RD5 | RD4 | RD3 | RD2 | RD1 | RD0 | xxxx |
| LATD | 02DC | LATD15 | LATD14 | LATD13 | LATD12 | LATD11 | LATD10 | LATD9 | LATD8 | LATD7 | LATD6 | LATD5 | LATD4 | LATD3 | LATD2 | LATD1 | LATD0 | 0000 |
| ODCD | 02DE | ODCD15 | ODCD14 | ODCD13 | ODCD12 | ODCD11 | ODCD10 | ODCD9 | ODCD8 | ODCD7 | ODCD6 | ODCD5 | ODCD4 | ODCD3 | ODCD2 | ODCD1 | ODCD0 | 0000 |

Legend: x = unknown value on Reset, — = unimplemented, read as '0'. Reset values are shown in hexadecimal.

TABLE 4-48: PORTD REGISTER MAP FOR dsPIC33FJ32GS406/606 AND dsPIC33FJ64GS406/606 DEVICES

| File Name | SFR Addr. | Bit 15 | Bit 14 | Bit 13 | Bit 12 | Bit 11 | Bit 10 | Bit 9 | Bit 8 | Bit 7 | Bit 6 | Bit 5 | Bit 4 | Bit 3 | Bit 2 | Bit 1 | Bit 0 | All Resets |
|-----------|-----------|--------|--------|--------|--------|---------|---------|--------|--------|--------|--------|--------|--------|--------|--------|--------|--------|------------|
| TRISD | 02D8 | — | — | — | — | TRISD11 | TRISD10 | TRISD9 | TRISD8 | TRISD7 | TRISD6 | TRISD5 | TRISD4 | TRISD3 | TRISD2 | TRISD1 | TRISD0 | 0FFF |
| PORTD | 02DA | — | — | — | — | RD11 | RD10 | RD9 | RD8 | RD7 | RD6 | RD5 | RD4 | RD3 | RD2 | RD1 | RD0 | xxxx |
| LATD | 02DC | — | — | — | — | LATD11 | LATD10 | LATD9 | LATD8 | LATD7 | LATD6 | LATD5 | LATD4 | LATD3 | LATD2 | LATD1 | LATD0 | 0000 |
| ODCD | 02DE | — | — | — | — | ODCD11 | ODCD10 | ODCD9 | ODCD8 | ODCD7 | ODCD6 | ODCD5 | ODCD4 | ODCD3 | ODCD2 | ODCD1 | ODCD0 | 0000 |

Legend: x = unknown value on Reset, — = unimplemented, read as '0'. Reset values are shown in hexadecimal.

TABLE 4-49: PORTE REGISTER MAP FOR dsPIC33FJ32GS608/610 AND dsPIC33FJ64GS608/610 DEVICES

| File Name | SFR Addr. | Bit 15 | Bit 14 | Bit 13 | Bit 12 | Bit 11 | Bit 10 | Bit 9 | Bit 8 | Bit 7 | Bit 6 | Bit 5 | Bit 4 | Bit 3 | Bit 2 | Bit 1 | Bit 0 | All Resets |
|-----------|-----------|--------|--------|--------|--------|--------|--------|--------|--------|--------|--------|--------|--------|--------|--------|--------|--------|------------|
| TRISE | 02E0 | — | — | — | — | — | — | TRISE9 | TRISE8 | TRISE7 | TRISE6 | TRISE5 | TRISE4 | TRISE3 | TRISE2 | TRISE1 | TRISE0 | 03FF |
| PORTE | 02E2 | — | — | — | — | — | — | RE9 | RE8 | RE7 | RE6 | RE5 | RE4 | RE3 | RE2 | RE1 | RE0 | xxxx |
| LATE | 02E4 | — | — | — | — | — | — | LATE9 | LATE8 | LATE7 | LATE6 | LATE5 | LATE4 | LATE3 | LATE2 | LATE1 | LATE0 | 0000 |
| ODCE | 02E6 | — | — | — | — | — | — | — | — | ODCE7 | ODCE6 | ODCE5 | ODCE4 | ODCE3 | ODCE2 | ODCE1 | ODCE0 | 0000 |

Legend: x = unknown value on Reset, — = unimplemented, read as '0'. Reset values are shown in hexadecimal.

TABLE 4-50: PORTE REGISTER MAP FOR dsPIC33FJ32GS406/606 AND dsPIC33FJ64GS406/606 DEVICES

| File Name | SFR Addr. | Bit 15 | Bit 14 | Bit 13 | Bit 12 | Bit 11 | Bit 10 | Bit 9 | Bit 8 | Bit 7 | Bit 6 | Bit 5 | Bit 4 | Bit 3 | Bit 2 | Bit 1 | Bit 0 | All Resets |
|-----------|-----------|--------|--------|--------|--------|--------|--------|-------|-------|--------|--------|--------|--------|--------|--------|--------|--------|------------|
| TRISE | 02E0 | — | — | — | — | — | — | — | — | TRISE7 | TRISE6 | TRISE5 | TRISE4 | TRISE3 | TRISE2 | TRISE1 | TRISE0 | 00FF |
| PORTE | 02E2 | — | — | — | — | — | — | — | — | RE7 | RE6 | RE5 | RE4 | RE3 | RE2 | RE1 | RE0 | xxxx |
| LATE | 02E4 | — | — | — | — | — | — | — | — | LATE7 | LATE6 | LATE5 | LATE4 | LATE3 | LATE2 | LATE1 | LATE0 | 0000 |
| ODCE | 02E6 | — | — | — | — | — | — | — | — | ODCE7 | ODCE6 | ODCE5 | ODCE4 | ODCE3 | ODCE2 | ODCE1 | ODCE0 | 0000 |

Legend: x = unknown value on Reset, — = unimplemented, read as '0'. Reset values are shown in hexadecimal.

TABLE 4-51: PORTF REGISTER MAP FOR dsPIC33FJ32GS610 AND dsPIC33FJ64GS610 DEVICES

| File Name | SFR Addr. | Bit 15 | Bit 14 | Bit 13 | Bit 12 | Bit 11 | Bit 10 | Bit 9 | Bit 8 | Bit 7 | Bit 6 | Bit 5 | Bit 4 | Bit 3 | Bit 2 | Bit 1 | Bit 0 | All Resets |
|-----------|-----------|--------|--------|---------|---------|--------|--------|-------|--------|--------|--------|--------|--------|--------|--------|--------|--------|------------|
| TRISF | 02E8 | — | — | TRISF13 | TRISF12 | — | — | — | TRISF8 | TRISF7 | TRISF6 | TRISF5 | TRISF4 | TRISF3 | TRISF2 | TRISF1 | TRISF0 | 30FF |
| PORTF | 02EA | — | — | RF13 | RF12 | — | — | — | RF8 | RF7 | RF6 | RF5 | RF4 | RF3 | RF2 | RF1 | RF0 | xxxx |
| LATF | 02EC | — | — | LATF13 | LATF12 | — | — | — | LATF8 | LATF7 | LATF6 | LATF5 | LATF4 | LATF3 | LATF2 | LATF1 | LATF0 | 0000 |
| ODCF | 02EE | — | — | ODCF13 | ODCF12 | — | — | — | ODCF8 | ODCF7 | ODCF6 | — | — | ODCF3 | ODCF2 | ODCF1 | — | 0000 |

Legend: x = unknown value on Reset, — = unimplemented, read as '0'. Reset values are shown in hexadecimal.

TABLE 4-52: PORTF REGISTER MAP FOR dsPIC33FJ32GS608 AND dsPIC33FJ64GS608 DEVICES

| File Name | SFR Addr. | Bit 15 | Bit 14 | Bit 13 | Bit 12 | Bit 11 | Bit 10 | Bit 9 | Bit 8 | Bit 7 | Bit 6 | Bit 5 | Bit 4 | Bit 3 | Bit 2 | Bit 1 | Bit 0 | All Resets |
|-----------|-----------|--------|--------|--------|--------|--------|--------|-------|--------|--------|--------|--------|--------|--------|--------|--------|--------|------------|
| TRISF | 02E8 | — | — | — | — | — | — | — | TRISF8 | TRISF7 | TRISF6 | TRISF5 | TRISF4 | TRISF3 | TRISF2 | TRISF1 | TRISF0 | 01FF |
| PORTF | 02EA | — | — | — | — | — | — | — | RF8 | RF7 | RF6 | RF5 | RF4 | RF3 | RF2 | RF1 | RF0 | xxxx |
| LATF | 02EC | — | — | — | — | — | — | — | LATF8 | LATF7 | LATF6 | LATF5 | LATF4 | LATF3 | LATF2 | LATF1 | LATF0 | 0000 |
| ODCF | 02EE | — | — | — | — | — | — | — | ODCF8 | ODCF7 | ODCF6 | — | — | ODCF3 | ODCF2 | ODCF1 | — | 0000 |

Legend: x = unknown value on Reset, — = unimplemented, read as '0'. Reset values are shown in hexadecimal.

TABLE 4-53: PORTF REGISTER MAP FOR dsPIC33FJ32GS406/606 AND dsPIC33FJ64GS406/606 DEVICES

| File Name | SFR Addr. | Bit 15 | Bit 14 | Bit 13 | Bit 12 | Bit 11 | Bit 10 | Bit 9 | Bit 8 | Bit 7 | Bit 6 | Bit 5 | Bit 4 | Bit 3 | Bit 2 | Bit 1 | Bit 0 | All Resets |
|-----------|-----------|--------|--------|--------|--------|--------|--------|-------|-------|-------|--------|--------|--------|--------|--------|--------|--------|------------|
| TRISF | 02E8 | — | — | — | — | — | — | — | — | — | TRISF6 | TRISF5 | TRISF4 | TRISF3 | TRISF2 | TRISF1 | TRISF0 | 007F |
| PORTF | 02EA | — | — | — | — | — | — | — | — | — | RF6 | RF5 | RF4 | RF3 | RF2 | RF1 | RF0 | xxxx |
| LATF | 02EC | — | — | — | — | — | — | — | — | — | LATF6 | LATF5 | LATF4 | LATF3 | LATF2 | LATF1 | LATF0 | 0000 |
| ODCF | 02EE | — | — | — | — | — | — | — | — | — | ODCF6 | — | — | ODCF3 | ODCF2 | ODCF1 | — | 0000 |

Legend: x = unknown value on Reset, — = unimplemented, read as '0'. Reset values are shown in hexadecimal.

TABLE 4-54: PORTG REGISTER MAP FOR dsPIC33FJ32GS610 AND dsPIC33FJ64GS610 DEVICES

| File Name | SFR Addr. | Bit 15 | Bit 14 | Bit 13 | Bit 12 | Bit 11 | Bit 10 | Bit 9 | Bit 8 | Bit 7 | Bit 6 | Bit 5 | Bit 4 | Bit 3 | Bit 2 | Bit 1 | Bit 0 | All Resets |
|-----------|-----------|---------|---------|---------|---------|--------|--------|--------|--------|--------|--------|-------|-------|--------|--------|--------|--------|------------|
| TRISG | 02F0 | TRISG15 | TRISG14 | TRISG13 | TRISG12 | — | — | TRISG9 | TRISG8 | TRISG7 | TRISG6 | — | — | TRISG3 | TRISG2 | TRISG1 | TRISG0 | F3CF |
| PORTG | 02F2 | RG15 | RG14 | RG13 | RG12 | — | — | RG9 | RG8 | RG7 | RG6 | — | — | RG3 | RG2 | RG1 | RG0 | xxxx |
| LATG | 02F4 | LATG15 | LATG14 | LATG13 | LATG12 | — | — | LATG9 | LATG8 | LATG7 | LATG6 | — | — | LATG3 | LATG2 | LATG1 | LATG0 | 0000 |
| ODCG | 02F6 | ODCG15 | ODCG14 | ODCG13 | ODCG12 | — | — | ODCG9 | ODCG8 | ODCG7 | ODCG6 | — | — | ODCG3 | ODCG2 | ODCG1 | ODCG0 | 0000 |

Legend: x = unknown value on Reset, — = unimplemented, read as '0'. Reset values are shown in hexadecimal.

TABLE 4-55: PORTG REGISTER MAP FOR dsPIC33FJ32GS608 AND dsPIC33FJ64GS608 DEVICES

| File Name | SFR Addr. | Bit 15 | Bit 14 | Bit 13 | Bit 12 | Bit 11 | Bit 10 | Bit 9 | Bit 8 | Bit 7 | Bit 6 | Bit 5 | Bit 4 | Bit 3 | Bit 2 | Bit 1 | Bit 0 | All Resets |
|-----------|-----------|--------|--------|--------|--------|--------|--------|--------|--------|--------|--------|-------|-------|--------|--------|--------|--------|------------|
| TRISG | 02F0 | — | — | — | — | — | — | TRISG9 | TRISG8 | TRISG7 | TRISG6 | — | — | TRISG3 | TRISG2 | TRISG1 | TRISG0 | 03CF |
| PORTG | 02F2 | — | — | — | — | — | — | RG9 | RG8 | RG7 | RG6 | — | — | RG3 | RG2 | RG1 | RG0 | xxxx |
| LATG | 02F4 | — | — | — | — | — | — | LATG9 | LATG8 | LATG7 | LATG6 | — | — | LATG3 | LATG2 | LATG1 | LATG0 | 0000 |
| ODCG | 02F6 | — | — | — | — | — | — | ODCG9 | ODCG8 | ODCG7 | ODCG6 | — | — | ODCG3 | ODCG2 | ODCG1 | ODCG0 | 0000 |

Legend: x = unknown value on Reset, — = unimplemented, read as '0'. Reset values are shown in hexadecimal.

TABLE 4-56: PORTG REGISTER MAP FOR dsPIC33FJ32GS406/606 AND dsPIC33FJ64GS406/606 DEVICES

| File Name | SFR Addr. | Bit 15 | Bit 14 | Bit 13 | Bit 12 | Bit 11 | Bit 10 | Bit 9 | Bit 8 | Bit 7 | Bit 6 | Bit 5 | Bit 4 | Bit 3 | Bit 2 | Bit 1 | Bit 0 | All Resets |
|-----------|-----------|--------|--------|--------|--------|--------|--------|--------|--------|--------|--------|-------|-------|--------|--------|-------|-------|------------|
| TRISG | 02F0 | — | — | — | — | — | — | TRISG9 | TRISG8 | TRISG7 | TRISG6 | — | — | TRISG3 | TRISG2 | — | — | 03CC |
| PORTG | 02F2 | — | — | — | — | — | — | RG9 | RG8 | RG7 | RG6 | — | — | RG3 | RG2 | — | — | xxxx |
| LATG | 02F4 | — | — | — | — | — | — | LATG9 | LATG8 | LATG7 | LATG6 | — | — | LATG3 | LATG2 | — | — | 0000 |
| ODCG | 02F6 | — | — | — | — | — | — | ODCG9 | ODCG8 | ODCG7 | ODCG6 | — | — | ODCG3 | ODCG2 | — | — | 0000 |

Legend: x = unknown value on Reset, — = unimplemented, read as '0'. Reset values are shown in hexadecimal.

TABLE 4-57: SYSTEM CONTROL REGISTER MAP

| File Name | SFR Addr. | Bit 15 | Bit 14 | Bit 13 | Bit 12 | Bit 11 | Bit 10 | Bit 9 | Bit 8 | Bit 7 | Bit 6 | Bit 5 | Bit 4 | Bit 3 | Bit 2 | Bit 1 | Bit 0 | All Resets |
|-----------|-----------|--------|-----------|---------|--------|------------|----------------|-------|-------------|--------------|----------|--------|-------------|-------|-------|-------|-------|---------------------|
| RCON | 0740 | TRAPR | IOPUWR | — | — | — | — | — | VREGS | EXTR | SWR | SWDTEN | WDTO | SLEEP | IDLE | BOR | POR | xxxx ⁽¹⁾ |
| OSCCON | 0742 | — | COSC<2:0> | | | — | NOSC<2:0> | | | CLKLOCK | — | LOCK | — | CF | — | — | OSWEN | 0300 ⁽²⁾ |
| CLKDIV | 0744 | ROI | DOZE<2:0> | | | DOZEN | FRCDIV<2:0> | | | PLLPOST<1:0> | | — | PLLPRE<4:0> | | | | | 0040 |
| PLLFBD | 0746 | — | — | — | — | — | — | — | PLLDIV<8:0> | | | | | | | | | 0030 |
| OSCTUN | 0748 | — | — | — | — | — | — | — | — | — | TUN<5:0> | | | | | | | 0000 |
| REFOCON | 074E | ROON | — | ROSSLP | ROSEL | RODIV<3:0> | | | | — | — | — | — | — | — | — | — | 0000 |
| ACLKCON | 0750 | ENAPLL | APLLCK | SELACLK | — | — | APSTSCCLR<2:0> | | | ASRCSEL | FRCSEL | — | — | — | — | — | — | 2300 |

Legend: x = unknown value on Reset, — = unimplemented, read as '0'. Reset values are shown in hexadecimal.

- Note 1:** The RCON register Reset values are dependent on the type of Reset.
Note 2: The OSCCON register Reset values are dependent on the FOSC_x Configuration bits and on the type of Reset.

TABLE 4-58: NVM REGISTER MAP

| File Name | SFR Addr. | Bit 15 | Bit 14 | Bit 13 | Bit 12 | Bit 11 | Bit 10 | Bit 9 | Bit 8 | Bit 7 | Bit 6 | Bit 5 | Bit 4 | Bit 3 | Bit 2 | Bit 1 | Bit 0 | All Resets |
|-----------|-----------|--------|--------|--------|--------|--------|--------|-------|-------|-------|-------------|-------|-------|------------|-------|-------|-------|---------------------|
| NVMCON | 0760 | WR | WREN | WRERR | — | — | — | — | — | — | ERASE | — | — | NVMOP<3:0> | | | | 0000 ⁽¹⁾ |
| NVMKEY | 0766 | — | — | — | — | — | — | — | — | — | NVMKEY<7:0> | | | | | | | 0000 |

Legend: x = unknown value on Reset, — = unimplemented, read as '0'. Reset values are shown in hexadecimal.

Note 1: Reset value shown is for POR only. Value on other Reset states is dependent on the state of memory write or erase operations at the time of Reset.

TABLE 4-59: PMD REGISTER MAP FOR dsPIC33FJ64GS610 DEVICES

| File Name | SFR Addr. | Bit 15 | Bit 14 | Bit 13 | Bit 12 | Bit 11 | Bit 10 | Bit 9 | Bit 8 | Bit 7 | Bit 6 | Bit 5 | Bit 4 | Bit 3 | Bit 2 | Bit 1 | Bit 0 | All Resets |
|-----------|-----------|--------|--------|--------|--------|--------|--------|--------|--------|--------|-------|--------|--------|--------|-------|--------|--------|------------|
| PMD1 | 0770 | T5MD | T4MD | T3MD | T2MD | T1MD | QE11MD | PWMMD | — | I2C1MD | U2MD | U1MD | SPI2MD | SPI1MD | — | C1MD | ADCMD | 0000 |
| PMD2 | 0772 | — | — | — | — | IC4MD | IC3MD | IC2MD | IC1MD | — | — | — | — | OC4MD | OC3MD | OC2MD | OC1MD | 0000 |
| PMD3 | 0774 | — | — | — | — | — | CMPMD | — | — | — | — | QE12MD | — | — | — | I2C2MD | — | 0000 |
| PMD4 | 0776 | — | — | — | — | — | — | — | — | — | — | — | — | REFOMD | — | — | — | 0000 |
| PMD6 | 077A | PWM8MD | PWM7MD | PWM6MD | PWM5MD | PWM4MD | PWM3MD | PWM2MD | PWM1MD | — | — | — | — | — | — | — | — | 0000 |
| PMD7 | 077C | — | — | — | — | CMP4MD | CMP3MD | CMP2MD | CMP1MD | — | — | — | — | — | — | — | PWM9MD | 0000 |

Legend: x = unknown value on Reset, — = unimplemented, read as '0'. Reset values are shown in hexadecimal.

TABLE 4-60: PMD REGISTER MAP FOR dsPIC33FJ32GS610 DEVICES

| File Name | SFR Addr. | Bit 15 | Bit 14 | Bit 13 | Bit 12 | Bit 11 | Bit 10 | Bit 9 | Bit 8 | Bit 7 | Bit 6 | Bit 5 | Bit 4 | Bit 3 | Bit 2 | Bit 1 | Bit 0 | All Resets |
|-----------|-----------|--------|--------|--------|--------|--------|--------|--------|--------|--------|-------|--------|--------|--------|-------|--------|--------|------------|
| PMD1 | 0770 | T5MD | T4MD | T3MD | T2MD | T1MD | QE11MD | PWMMD | — | I2C1MD | U2MD | U1MD | SPI2MD | SPI1MD | — | — | ADCMD | 0000 |
| PMD2 | 0772 | — | — | — | — | IC4MD | IC3MD | IC2MD | IC1MD | — | — | — | — | OC4MD | OC3MD | OC2MD | OC1MD | 0000 |
| PMD3 | 0774 | — | — | — | — | — | CMPMD | — | — | — | — | QE12MD | — | — | — | I2C2MD | — | 0000 |
| PMD4 | 0776 | — | — | — | — | — | — | — | — | — | — | — | — | REFOMD | — | — | — | 0000 |
| PMD6 | 077A | PWM8MD | PWM7MD | PWM6MD | PWM5MD | PWM4MD | PWM3MD | PWM2MD | PWM1MD | — | — | — | — | — | — | — | — | 0000 |
| PMD7 | 077C | — | — | — | — | CMP4MD | CMP3MD | CMP2MD | CMP1MD | — | — | — | — | — | — | — | PWM9MD | 0000 |

Legend: x = unknown value on Reset, — = unimplemented, read as '0'. Reset values are shown in hexadecimal.

TABLE 4-61: PMD REGISTER MAP FOR dsPIC33FJ64GS608 DEVICES

| File Name | SFR Addr. | Bit 15 | Bit 14 | Bit 13 | Bit 12 | Bit 11 | Bit 10 | Bit 9 | Bit 8 | Bit 7 | Bit 6 | Bit 5 | Bit 4 | Bit 3 | Bit 2 | Bit 1 | Bit 0 | All Resets |
|-----------|-----------|--------|--------|--------|--------|--------|--------|--------|--------|--------|-------|--------|--------|--------|-------|--------|-------|------------|
| PMD1 | 0770 | T5MD | T4MD | T3MD | T2MD | T1MD | QE11MD | PWMMD | — | I2C1MD | U2MD | U1MD | SPI2MD | SPI1MD | — | C1MD | ADCMD | 0000 |
| PMD2 | 0772 | — | — | — | — | IC4MD | IC3MD | IC2MD | IC1MD | — | — | — | — | OC4MD | OC3MD | OC2MD | OC1MD | 0000 |
| PMD3 | 0774 | — | — | — | — | — | CMPMD | — | — | — | — | QE12MD | — | — | — | I2C2MD | — | 0000 |
| PMD4 | 0776 | — | — | — | — | — | — | — | — | — | — | — | — | REFOMD | — | — | — | 0000 |
| PMD6 | 077A | PWM8MD | PWM7MD | PWM6MD | PWM5MD | PWM4MD | PWM3MD | PWM2MD | PWM1MD | — | — | — | — | — | — | — | — | 0000 |
| PMD7 | 077C | — | — | — | — | CMP4MD | CMP3MD | CMP2MD | CMP1MD | — | — | — | — | — | — | — | — | 0000 |

Legend: x = unknown value on Reset, — = unimplemented, read as '0'. Reset values are shown in hexadecimal.

TABLE 4-62: PMD REGISTER MAP FOR dsPIC33FJ32GS608 DEVICES

| File Name | SFR Addr. | Bit 15 | Bit 14 | Bit 13 | Bit 12 | Bit 11 | Bit 10 | Bit 9 | Bit 8 | Bit 7 | Bit 6 | Bit 5 | Bit 4 | Bit 3 | Bit 2 | Bit 1 | Bit 0 | All Resets |
|-----------|-----------|--------|--------|--------|--------|--------|--------|--------|--------|--------|-------|--------|--------|--------|-------|--------|-------|------------|
| PMD1 | 0770 | T5MD | T4MD | T3MD | T2MD | T1MD | QE11MD | PWMMD | — | I2C1MD | U2MD | U1MD | SPI2MD | SPI1MD | — | — | ADCMD | 0000 |
| PMD2 | 0772 | — | — | — | — | IC4MD | IC3MD | IC2MD | IC1MD | — | — | — | — | OC4MD | OC3MD | OC2MD | OC1MD | 0000 |
| PMD3 | 0774 | — | — | — | — | — | CMPMD | — | — | — | — | QE12MD | — | — | — | I2C2MD | — | 0000 |
| PMD4 | 0776 | — | — | — | — | — | — | — | — | — | — | — | — | REFOMD | — | — | — | 0000 |
| PMD6 | 077A | PWM8MD | PWM7MD | PWM6MD | PWM5MD | PWM4MD | PWM3MD | PWM2MD | PWM1MD | — | — | — | — | — | — | — | — | 0000 |
| PMD7 | 077C | — | — | — | — | CMP4MD | CMP3MD | CMP2MD | CMP1MD | — | — | — | — | — | — | — | — | 0000 |

Legend: x = unknown value on Reset, — = unimplemented, read as '0'. Reset values are shown in hexadecimal.

TABLE 4-63: PMD REGISTER MAP FOR dsPIC33FJ64GS606 DEVICES

| File Name | SFR Addr. | Bit 15 | Bit 14 | Bit 13 | Bit 12 | Bit 11 | Bit 10 | Bit 9 | Bit 8 | Bit 7 | Bit 6 | Bit 5 | Bit 4 | Bit 3 | Bit 2 | Bit 1 | Bit 0 | All Resets |
|-----------|-----------|--------|--------|--------|--------|--------|--------|--------|--------|--------|-------|--------|--------|--------|-------|--------|-------|------------|
| PMD1 | 0770 | T5MD | T4MD | T3MD | T2MD | T1MD | QE11MD | PWMMD | — | I2C1MD | U2MD | U1MD | SPI2MD | SPI1MD | — | C1MD | ADCMD | 0000 |
| PMD2 | 0772 | — | — | — | — | IC4MD | IC3MD | IC2MD | IC1MD | — | — | — | — | OC4MD | OC3MD | OC2MD | OC1MD | 0000 |
| PMD3 | 0774 | — | — | — | — | — | CMPMD | — | — | — | — | QE12MD | — | — | — | I2C2MD | — | 0000 |
| PMD4 | 0776 | — | — | — | — | — | — | — | — | — | — | — | — | REFOMD | — | — | — | 0000 |
| PMD6 | 077A | — | — | PWM6MD | PWM5MD | PWM4MD | PWM3MD | PWM2MD | PWM1MD | — | — | — | — | — | — | — | — | 0000 |
| PMD7 | 077C | — | — | — | — | CMP4MD | CMP3MD | CMP2MD | CMP1MD | — | — | — | — | — | — | — | — | 0000 |

Legend: x = unknown value on Reset, — = unimplemented, read as '0'. Reset values are shown in hexadecimal.

TABLE 4-64: PMD REGISTER MAP FOR dsPIC33FJ32GS606 DEVICES

| File Name | SFR Addr. | Bit 15 | Bit 14 | Bit 13 | Bit 12 | Bit 11 | Bit 10 | Bit 9 | Bit 8 | Bit 7 | Bit 6 | Bit 5 | Bit 4 | Bit 3 | Bit 2 | Bit 1 | Bit 0 | All Resets |
|-----------|-----------|--------|--------|--------|--------|--------|--------|--------|--------|--------|-------|--------|--------|--------|-------|--------|-------|------------|
| PMD1 | 0770 | T5MD | T4MD | T3MD | T2MD | T1MD | QE11MD | PWMMMD | — | I2C1MD | U2MD | U1MD | SPI2MD | SPI1MD | — | — | ADCMD | 0000 |
| PMD2 | 0772 | — | — | — | — | IC4MD | IC3MD | IC2MD | IC1MD | — | — | — | — | OC4MD | OC3MD | OC2MD | OC1MD | 0000 |
| PMD3 | 0774 | — | — | — | — | — | CMPMD | — | — | — | — | QE12MD | — | — | — | I2C2MD | — | 0000 |
| PMD4 | 0776 | — | — | — | — | — | — | — | — | — | — | — | — | REFOMD | — | — | — | 0000 |
| PMD6 | 077A | — | — | PWM6MD | PWM5MD | PWM4MD | PWM3MD | PWM2MD | PWM1MD | — | — | — | — | — | — | — | — | 0000 |
| PMD7 | 077C | — | — | — | — | CMP4MD | CMP3MD | CMP2MD | CMP1MD | — | — | — | — | — | — | — | — | 0000 |

Legend: x = unknown value on Reset, — = unimplemented, read as '0'. Reset values are shown in hexadecimal.

TABLE 4-65: PMD REGISTER MAP FOR dsPIC33FJ32GS406 AND dsPIC33FJ64GS406 DEVICES

| File Name | SFR Addr. | Bit 15 | Bit 14 | Bit 13 | Bit 12 | Bit 11 | Bit 10 | Bit 9 | Bit 8 | Bit 7 | Bit 6 | Bit 5 | Bit 4 | Bit 3 | Bit 2 | Bit 1 | Bit 0 | All Resets |
|-----------|-----------|--------|--------|--------|--------|--------|--------|--------|--------|--------|-------|--------|--------|--------|-------|--------|-------|------------|
| PMD1 | 0770 | T5MD | T4MD | T3MD | T2MD | T1MD | QE11MD | PWMMMD | — | I2C1MD | U2MD | U1MD | SPI2MD | SPI1MD | — | — | ADCMD | 0000 |
| PMD2 | 0772 | — | — | — | — | IC4MD | IC3MD | IC2MD | IC1MD | — | — | — | — | OC4MD | OC3MD | OC2MD | OC1MD | 0000 |
| PMD3 | 0774 | — | — | — | — | — | — | — | — | — | — | QE12MD | — | — | — | I2C2MD | — | 0000 |
| PMD4 | 0776 | — | — | — | — | — | — | — | — | — | — | — | — | REFOMD | — | — | — | 0000 |
| PMD6 | 077A | — | — | PWM6MD | PWM5MD | PWM4MD | PWM3MD | PWM2MD | PWM1MD | — | — | — | — | — | — | — | — | 0000 |

Legend: x = unknown value on Reset, — = unimplemented, read as '0'. Reset values are shown in hexadecimal.

4.2.7 SOFTWARE STACK

In addition to its use as a working register, the W15 register in the dsPIC33FJ32GS406/606/608/610 and dsPIC33FJ64GS406/606/608/610 devices is also used as a Software Stack Pointer. The Stack Pointer always points to the first available free word and grows from lower to higher addresses. It predecrements for stack pops and post-increments for stack pushes, as shown in Figure 4-6. For a PC push during any CALL instruction, the MSb of the PC is zero-extended before the push, ensuring that the MSb is always clear.

Note: A PC push during exception processing concatenates the SRL register to the MSb of the PC prior to the push.

The Stack Pointer Limit register (SPLIM) associated with the Stack Pointer sets an upper address boundary for the stack. SPLIM is uninitialized at Reset. As is the case for the Stack Pointer, SPLIM<0> is forced to '0' because all stack operations must be word-aligned.

Whenever an EA is generated using W15 as a source or destination pointer, the resulting address is compared with the value in SPLIM. If the contents of the Stack Pointer (W15) and the SPLIM register are equal and a push operation is performed, a stack error trap will not occur. The stack error trap will occur on a subsequent push operation. For example, to cause a stack error trap when the stack grows beyond address 0x1800 in RAM, initialize the SPLIM with the value, 0x17FE.

Similarly, a Stack Pointer underflow (stack error) trap is generated when the Stack Pointer address is found to be less than 0x0800. This prevents the stack from interfering with the Special Function Register (SFR) space.

A write to the SPLIM register should not be immediately followed by an indirect read operation using W15.

FIGURE 4-6: CALL STACK FRAME



4.3 Instruction Addressing Modes

The addressing modes shown in Table 4-66 form the basis of the addressing modes optimized to support the specific features of individual instructions. The addressing modes provided in the MAC class of instructions differ from those in the other instruction types.

4.3.1 FILE REGISTER INSTRUCTIONS

Most file register instructions use a 13-bit address field (f) to directly address data present in the first 8192 bytes of data memory (Near Data Space). Most file register instructions employ a working register, W0, which is denoted as WREG in these instructions. The destination is typically either the same file register or WREG (with the exception of the MUL instruction), which writes the result to a register or register pair. The MOV instruction allows additional flexibility and can access the entire data space.

4.3.2 MCU INSTRUCTIONS

The three-operand MCU instructions are of the form:

$$\text{Operand 3} = \text{Operand 1} \langle \text{function} \rangle \text{Operand 2}$$

where Operand 1 is always a working register (that is, the addressing mode can only be register direct), which is referred to as Wb. Operand 2 can be a W register, fetched from data memory, or a 5-bit literal. The result location can be either a W register or a data memory location. The following addressing modes are supported by MCU instructions:

- Register Direct
- Register Indirect
- Register Indirect Post-Modified
- Register Indirect Pre-Modified
- 5-Bit or 10-Bit Literal

Note: Not all instructions support all the addressing modes given above. Individual instructions can support different subsets of these addressing modes.

TABLE 4-66: FUNDAMENTAL ADDRESSING MODES SUPPORTED

| Addressing Mode | Description |
|---|--|
| File Register Direct | The address of the file register is specified explicitly. |
| Register Direct | The contents of a register are accessed directly. |
| Register Indirect | The contents of Wn forms the Effective Address (EA). |
| Register Indirect Post-Modified | The contents of Wn forms the EA. Wn is post-modified (incremented or decremented) by a constant value. |
| Register Indirect Pre-Modified | Wn is pre-modified (incremented or decremented) by a signed constant value to form the EA. |
| Register Indirect with Register Offset (Register Indexed) | The sum of Wn and Wb forms the EA. |
| Register Indirect with Literal Offset | The sum of Wn and a literal forms the EA. |

4.3.3 MOVE AND ACCUMULATOR INSTRUCTIONS

Move instructions and the DSP accumulator class of instructions provide a greater degree of addressing flexibility than other instructions. In addition to the addressing modes supported by most MCU instructions, move and accumulator instructions also support Register Indirect with Register Offset Addressing mode, also referred to as Register Indexed mode.

Note: For the `MOV` instructions, the addressing mode specified in the instruction can differ for the source and destination EA. However, the 4-bit Wb (Register Offset) field is shared by both source and destination (but typically only used by one).

In summary, the following addressing modes are supported by move and accumulator instructions:

- Register Direct
- Register Indirect
- Register Indirect Post-modified
- Register Indirect Pre-modified
- Register Indirect with Register Offset (Indexed)
- Register Indirect with Literal Offset
- 8-Bit Literal
- 16-Bit Literal

Note: Not all instructions support all the addressing modes given above. Individual instructions may support different subsets of these addressing modes.

4.3.4 MAC INSTRUCTIONS

The dual source operand DSP instructions (`CLR`, `ED`, `EDAC`, `MAC`, `MPY`, `MPY.N`, `MOVSAC` and `MSC`), also referred to as `MAC` instructions, use a simplified set of addressing modes to allow the user application to effectively manipulate the Data Pointers through Register Indirect tables.

The two-source operand, prefetch registers must be members of the set: {W8, W9, W10, W11}. For data reads, W8 and W9 are always directed to the X RAGU, and W10 and W11 are always directed to the Y AGU. The Effective Addresses generated (before and after modification) must, therefore, be valid addresses within X data space for W8 and W9 and Y data space for W10 and W11.

Note: Register Indirect with Register Offset Addressing mode is available only for W9 (in X space) and W11 (in Y space).

In summary, the following addressing modes are supported by the `MAC` class of instructions:

- Register Indirect
- Register Indirect Post-Modified by 2
- Register Indirect Post-Modified by 4
- Register Indirect Post-Modified by 6
- Register Indirect with Register Offset (Indexed)

4.3.5 OTHER INSTRUCTIONS

Besides the addressing modes outlined previously, some instructions use literal constants of various sizes. For example, `BRA` (branch) instructions use 16-bit signed literals to specify the branch destination directly, whereas the `DISI` instruction uses a 14-bit unsigned literal field. In some instructions, such as `ADD Acc`, the source of an operand or result is implied by the opcode itself. Certain operations, such as `NOB`, do not have any operands.

4.4 Modulo Addressing

Modulo Addressing mode is a method used to provide an automated means to support circular data buffers using hardware. The objective is to remove the need for software to perform data address boundary checks when executing tightly looped code, as is typical in many DSP algorithms.

Modulo Addressing can operate in either data or program space (since the Data Pointer mechanism is essentially the same for both). One circular buffer can be supported in each of the X (which also provides the pointers into program space) and Y data spaces. Modulo Addressing can operate on any W Register Pointer. However, it is not advisable to use W14 or W15 for Modulo Addressing since these two registers are used as the Stack Frame Pointer and Stack Pointer, respectively.

In general, any particular circular buffer can be configured to operate in only one direction as there are certain restrictions on the buffer start address (for incrementing buffers), or end address (for decrementing buffers), based upon the direction of the buffer.

The only exception to the usage restrictions is for buffers that have a power-of-two length. As these buffers satisfy the start and end address criteria, they can operate in a bidirectional mode (that is, address boundary checks are performed on both the lower and upper address boundaries).

4.4.1 START AND END ADDRESS

The Modulo Addressing scheme requires that a starting and ending address be specified and loaded into the 16-bit Modulo Buffer Address registers: XMODSRT, XMODEND, YMODSRT and YMODEND (see Table 4-1).

Note: Y Space Modulo Addressing EA calculations assume word-sized data (LSb of every EA is always clear).

The length of a circular buffer is not directly specified. It is determined by the difference between the corresponding start and end addresses. The maximum possible length of the circular buffer is 32K words (64 Kbytes).

4.4.2 W ADDRESS REGISTER SELECTION

The Modulo and Bit-Reversed Addressing Control register, MODCON<15:0>, contains enable flags as well as a W register field to specify the W Address registers. The XWM and YWM fields select the registers that will operate with Modulo Addressing:

- If XWM = 15, X RAGU and X WAGU Modulo Addressing is disabled.
- If YWM = 15, Y AGU Modulo Addressing is disabled.

The X Address Space Pointer W register (XWM), to which Modulo Addressing is to be applied, is stored in MODCON<3:0> (see Table 4-1). Modulo Addressing is enabled for X data space when XWM is set to any value other than '15' and the XMODEN bit is set at MODCON<15>.

The Y Address Space Pointer W register (YWM) to which Modulo Addressing is to be applied is stored in MODCON<7:4>. Modulo Addressing is enabled for Y data space when YWM is set to any value other than '15' and the YMODEN bit is set at MODCON<14>.

FIGURE 4-7: MODULO ADDRESSING OPERATION EXAMPLE



4.4.3 MODULO ADDRESSING APPLICABILITY

Modulo Addressing can be applied to the Effective Address (EA) calculation associated with any W register. Address boundaries check for addresses equal to:

- Upper boundary addresses for incrementing buffers
- Lower boundary addresses for decrementing buffers

It is important to realize that the address boundaries check for addresses less than or greater than the upper (for incrementing buffers) and lower (for decrementing buffers) boundary addresses (not just equal to). Address changes can, therefore, jump beyond boundaries and still be adjusted correctly.

Note: The modulo corrected Effective Address is written back to the register only when Pre-Modify or Post-Modify Addressing mode is used to compute the Effective Address. When an address offset (such as [W7 + W2]) is used, Modulo Addressing correction is performed but the contents of the register remain unchanged.

4.5 Bit-Reversed Addressing

Bit-Reversed Addressing mode is intended to simplify data re-ordering for radix-2 FFT algorithms. It is supported by the X AGU for data writes only.

The modifier, which can be a constant value or register contents, is regarded as having its bit order reversed. The address source and destination are kept in normal order. Thus, the only operand requiring reversal is the modifier.

4.5.1 BIT-REVERSED ADDRESSING IMPLEMENTATION

Bit-Reversed Addressing mode is enabled in any of these situations:

- BWMx bits (W register selection) in the MODCON register are any value other than '15' (the stack cannot be accessed using Bit-Reversed Addressing)
- The BREN bit is set in the XBREV register
- The addressing mode used is Register Indirect with Pre-Increment or Post-Increment

If the length of a bit-reversed buffer is $M = 2^N$ bytes, the last 'N' bits of the data buffer start address must be zeros.

XB<14:0> is the Bit-Reversed Addressing modifier, or 'pivot point,' which is typically a constant. In the case of an FFT computation, its value is equal to half of the FFT data buffer size.

Note: All bit-reversed EA calculations assume word-sized data (LSb of every EA is always clear). The XB value is scaled accordingly to generate compatible (byte) addresses.

When enabled, Bit-Reversed Addressing is executed only for Register Indirect with Pre-Increment or Post-Increment Addressing and word-sized data writes. It will not function for any other addressing mode or for byte-sized data, and normal addresses are generated instead. When Bit-Reversed Addressing is active, the W Address Pointer is always added to the address modifier (XB), and the offset associated with the Register Indirect Addressing mode is ignored. In addition, as word-sized data is a requirement, the LSb of the EA is ignored (and always clear).

Note: Modulo Addressing and Bit-Reversed Addressing should not be enabled together. If an application attempts to do so, Bit-Reversed Addressing will assume priority when active for the X WAGU and X WAGU, and Modulo Addressing will be disabled. However, Modulo Addressing will continue to function in the X RAGU.

If Bit-Reversed Addressing has already been enabled by setting the BREN (XBREV<15>) bit, a write to the XBREV register should not be immediately followed by an indirect read operation using the W register that has been designated as the Bit-Reversed Pointer.

FIGURE 4-8: BIT-REVERSED ADDRESS EXAMPLE



TABLE 4-67: BIT-REVERSED ADDRESS SEQUENCE (16-ENTRY)

| Normal Address | | | | | Bit-Reversed Address | | | | |
|----------------|----|----|----|---------|----------------------|----|----|----|---------|
| A3 | A2 | A1 | A0 | Decimal | A3 | A2 | A1 | A0 | Decimal |
| 0 | 0 | 0 | 0 | 0 | 0 | 0 | 0 | 0 | 0 |
| 0 | 0 | 0 | 1 | 1 | 1 | 0 | 0 | 0 | 8 |
| 0 | 0 | 1 | 0 | 2 | 0 | 1 | 0 | 0 | 4 |
| 0 | 0 | 1 | 1 | 3 | 1 | 1 | 0 | 0 | 12 |
| 0 | 1 | 0 | 0 | 4 | 0 | 0 | 1 | 0 | 2 |
| 0 | 1 | 0 | 1 | 5 | 1 | 0 | 1 | 0 | 10 |
| 0 | 1 | 1 | 0 | 6 | 0 | 1 | 1 | 0 | 6 |
| 0 | 1 | 1 | 1 | 7 | 1 | 1 | 1 | 0 | 14 |
| 1 | 0 | 0 | 0 | 8 | 0 | 0 | 0 | 1 | 1 |
| 1 | 0 | 0 | 1 | 9 | 1 | 0 | 0 | 1 | 9 |
| 1 | 0 | 1 | 0 | 10 | 0 | 1 | 0 | 1 | 5 |
| 1 | 0 | 1 | 1 | 11 | 1 | 1 | 0 | 1 | 13 |
| 1 | 1 | 0 | 0 | 12 | 0 | 0 | 1 | 1 | 3 |
| 1 | 1 | 0 | 1 | 13 | 1 | 0 | 1 | 1 | 11 |
| 1 | 1 | 1 | 0 | 14 | 0 | 1 | 1 | 1 | 7 |
| 1 | 1 | 1 | 1 | 15 | 1 | 1 | 1 | 1 | 15 |

4.6 Interfacing Program and Data Memory Spaces

The dsPIC33FJ32GS406/606/608/610 and dsPIC33FJ64GS406/606/608/610 architecture uses a 24-bit-wide program space and a 16-bit-wide data space. The architecture is also a modified Harvard scheme, meaning that data can also be present in the program space. To use this data successfully, it must be accessed in a way that preserves the alignment of information in both spaces.

Aside from normal execution, the dsPIC33FJ32GS406/606/608/610 and dsPIC33FJ64GS406/606/608/610 architecture provides two methods by which program space can be accessed during operation:

- Using table instructions to access individual bytes or words anywhere in the program space
- Remapping a portion of the program space into the data space (Program Space Visibility)

Table instructions allow an application to read or write to small areas of the program memory. This capability makes the method ideal for accessing data tables that need to be updated periodically. It also allows access to all bytes of the program word. The remapping method allows an application to access a large block of data on a read-only basis, which is ideal for look-ups from a large table of static data. The application can only access the least significant word of the program word.

4.6.1 ADDRESSING PROGRAM SPACE

Since the address ranges for the data and program spaces are 16 and 24 bits, respectively, a method is needed to create a 23-bit or 24-bit program address from 16-bit data registers. The solution depends on the interface method to be used.

For table operations, the 8-bit Table Page register (TBLPAG) is used to define a 32K word region within the program space. This is concatenated with a 16-bit EA to arrive at a full 24-bit program space address. In this format, the Most Significant bit of TBLPAG is used to determine if the operation occurs in the user memory (TBLPAG<7> = 0) or the configuration memory (TBLPAG<7> = 1).

For remapping operations, the 8-bit Program Space Visibility register (PSVPAG) is used to define a 16K word page in the program space. When the Most Significant bit of the EA is '1', PSVPAG is concatenated with the lower 15 bits of the EA to form a 23-bit program space address. Unlike table operations, this limits remapping operations strictly to the user memory area.

Table 4-68 and Figure 4-9 show how the program EA is created for table operations and remapping accesses from the data EA. Here, P<23:0> refers to a program space word and D<15:0> refers to a data space word.

TABLE 4-68: PROGRAM SPACE ADDRESS CONSTRUCTION

| Access Type | Access Space | Program Space Address | | | | |
|--|---------------|------------------------------------|-------------|---------------|------------------------------|-----|
| | | <23> | <22:16> | <15> | <14:1> | <0> |
| Instruction Access (Code Execution) | User | 0 | PC<22:1> | | | 0 |
| | | 0xx xxxx xxxxx xxxxx xxxxx xxx0 | | | | |
| TBLRD/TBLWT (Byte/Word Read/Write) | User | TBLPAG<7:0> | | Data EA<15:0> | | |
| | | 0xxx xxxxx xxxxx xxxxx xxxxx xxxxx | | | | |
| | Configuration | TBLPAG<7:0> | | Data EA<15:0> | | |
| | | 1xxx xxxxx xxxxx xxxxx xxxxx xxxxx | | | | |
| Program Space Visibility (Block Remap/Read) | User | 0 | PSVPAG<7:0> | | Data EA<14:0> ⁽¹⁾ | |
| | | 0 | xxxx xxxxx | | xxx xxxxx xxxxx xxxxx | |

Note 1: Data EA<15> is always '1' in this case, but is not used in calculating the program space address. Bit 15 of the address is PSVPAG<0>.

FIGURE 4-9: DATA ACCESS FROM PROGRAM SPACE ADDRESS GENERATION

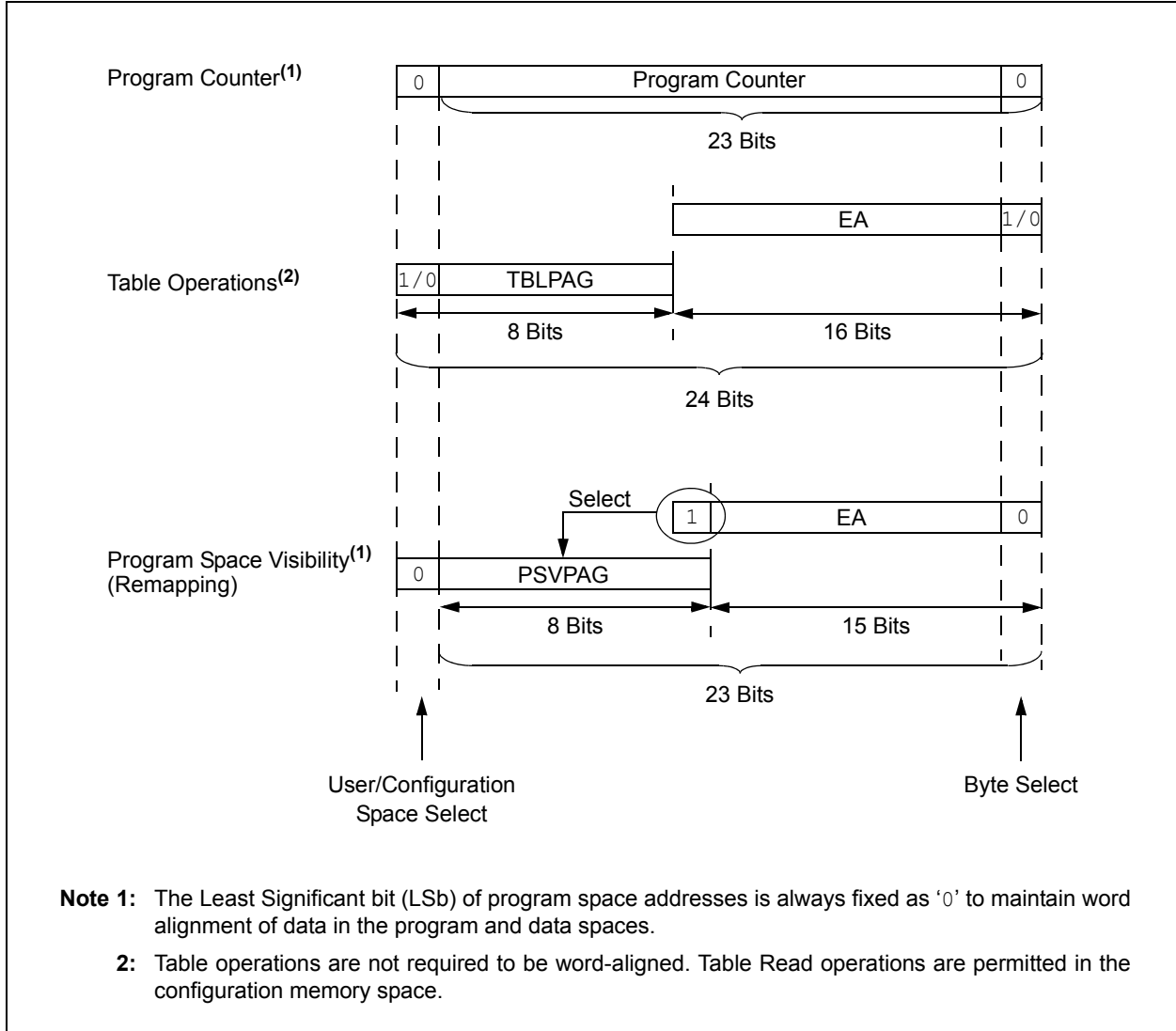

4.6.2 DATA ACCESS FROM PROGRAM MEMORY USING TABLE INSTRUCTIONS

The `TBLRDL` and `TBLWTL` instructions offer a direct method of reading or writing the lower word of any address within the program space without going through data space. The `TBLRDH` and `TBLWTH` instructions are the only method to read or write the upper 8 bits of a program space word as data.

The PC is incremented by two for each successive 24-bit program word. This allows program memory addresses to directly map to data space addresses. Program memory can thus be regarded as two 16-bit-wide word address spaces, residing side by side, each with the same address range. `TBLRDL` and `TBLWTL` access the space that contains the least significant data word. `TBLRDH` and `TBLWTH` access the space that contains the upper data byte.

Two table instructions are provided to move byte or word-sized (16-bit) data to and from program space. Both function as either byte or word operations.

- `TBLRDL` (Table Read Low):
 - In Word mode, this instruction maps the lower word of the program space location ($P<15:0>$) to a data address ($D<15:0>$).

- In Byte mode, either the upper or lower byte of the lower program word is mapped to the lower byte of a data address. The upper byte is selected when Byte Select is '1'; the lower byte is selected when it is '0'.

- `TBLRDH` (Table Read High):
 - In Word mode, this instruction maps the entire upper word of a program address ($P<23:16>$) to a data address. Note that $D<15:8>$, the 'phantom byte', will always be '0'.
 - In Byte mode, this instruction maps the upper or lower byte of the program word to $D<7:0>$ of the data address, in the `TBLRDL` instruction. The data is always '0' when the upper 'phantom' byte is selected (Byte Select = 1).

Similarly, two table instructions, `TBLWTH` and `TBLWTL`, are used to write individual bytes or words to a program space address. The details of their operation are explained in [Section 5.0 "Flash Program Memory"](#).

For all table operations, the area of program memory space to be accessed is determined by the Table Page register (TBLPAG). TBLPAG covers the entire program memory space of the device, including user and configuration spaces. When $TBLPAG<7> = 0$, the table page is located in the user memory space. When $TBLPAG<7> = 1$, the page is located in configuration space.

FIGURE 4-10: ACCESSING PROGRAM MEMORY WITH TABLE INSTRUCTIONS



4.6.3 READING DATA FROM PROGRAM MEMORY USING PROGRAM SPACE VISIBILITY

The upper 32 Kbytes of data space may optionally be mapped into any 16K word page of the program space. This option provides transparent access to stored constant data from the data space without the need to use special instructions (such as TBLRD/L/H).

Program space access through the data space occurs if the Most Significant bit of the data space EA is '1' and program space visibility is enabled by setting the PSV bit in the Core Control register (CORCON<2>). The location of the program memory space to be mapped into the data space is determined by the Program Space Visibility Page register (PSVPAG). This 8-bit register defines any one of 256 possible pages of 16K words in program space. In effect, PSVPAG functions as the upper 8 bits of the program memory address, with the 15 bits of the EA functioning as the lower bits. By incrementing the PC by 2 for each program memory word, the lower 15 bits of data space addresses directly map to the lower 15 bits in the corresponding program space addresses.

Data reads to this area add a cycle to the instruction being executed, since two program memory fetches are required.

Although each data space address 8000h and higher maps directly into a corresponding program memory address (see Figure 4-11), only the lower 16 bits of the

24-bit program word are used to contain the data. The upper 8 bits of any program space location used as data should be programmed with '1111 1111' or '0000 0000' to force a NOP. This prevents possible issues should the area of code ever be accidentally executed.

Note: PSV access is temporarily disabled during Table Reads/Writes.

For operations that use PSV and are executed outside a REPEAT loop, the MOV and MOV.D instructions require one instruction cycle in addition to the specified execution time. All other instructions require two instruction cycles in addition to the specified execution time.

For operations that use PSV and are executed inside a REPEAT loop, these instances require two instruction cycles in addition to the specified execution time of the instruction:

- Execution in the first iteration
- Execution in the last iteration
- Execution prior to exiting the loop due to an interrupt
- Execution upon re-entering the loop after an interrupt is serviced

Any other iteration of the REPEAT loop will allow the instruction using PSV to access data, to execute in a single cycle.

FIGURE 4-11: PROGRAM SPACE VISIBILITY OPERATION

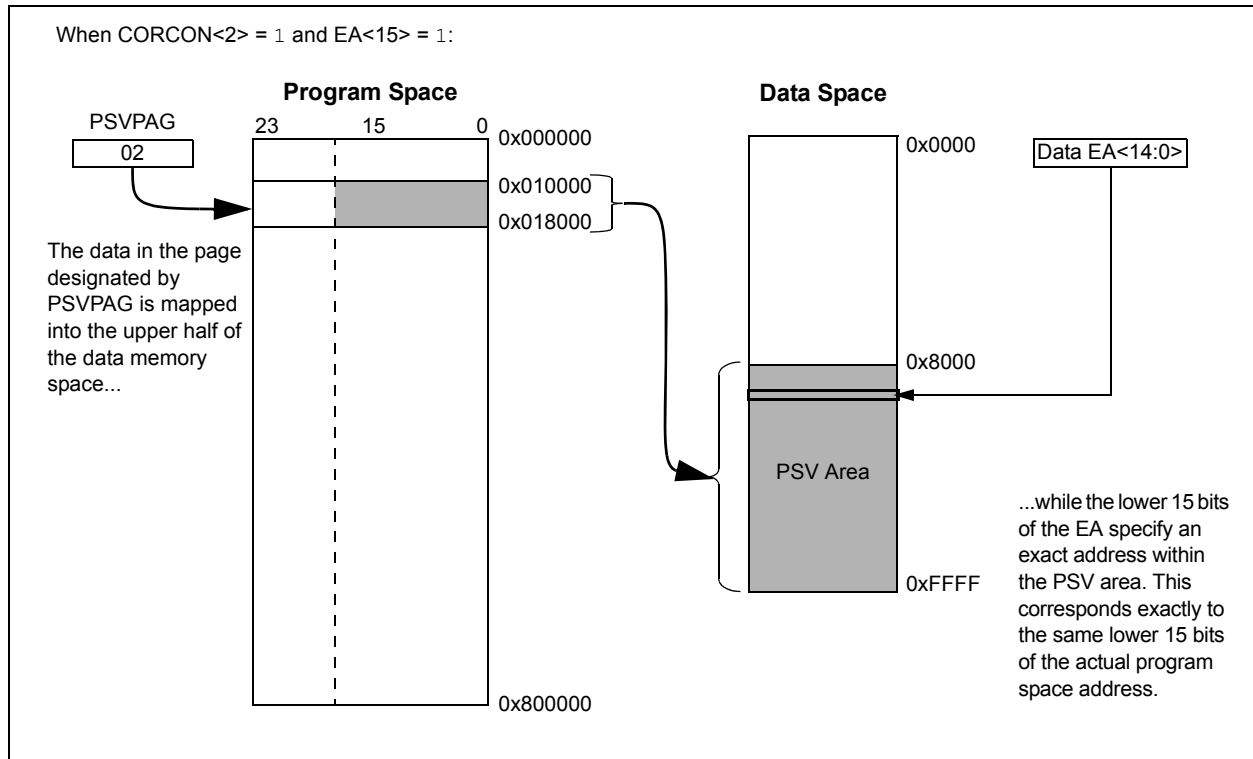

NOTES:

5.0 FLASH PROGRAM MEMORY

Note 1: This data sheet summarizes the features of the dsPIC33FJ32GS406/606/608/610 and dsPIC33FJ64GS406/606/608/610 families of devices. It is not intended to be a comprehensive reference source. To complement the information in this data sheet, refer to **Section 5. “Flash Programming”** (DS70191) in the “dsPIC33F/PIC24H Family Reference Manual”, which is available from the Microchip web site (www.microchip.com).

2: Some registers and associated bits described in this section may not be available on all devices. Refer to **Section 4.0 “Memory Organization”** in this data sheet for device-specific register and bit information.

The dsPIC33FJ32GS406/606/608/610 and dsPIC33FJ64GS406/606/608/610 devices contain internal Flash program memory for storing and executing application code. The memory is readable, writable and erasable during normal operation over the entire VDD range.

Flash memory can be programmed in two ways:

- In-Circuit Serial Programming™ (ICSP™)
- Run-Time Self-Programming (RTSP)

ICSP allows a dsPIC33FJ32GS406/606/608/610 and dsPIC33FJ64GS406/606/608/610 device to be serially programmed while in the end application circuit. This is done with two lines for programming clock and programming data (one of the alternate programming pin pairs: PGEC1/PGED1, PGEC2/PGED2 or PGEC3/

PGED3), and three other lines for power (VDD), ground (VSS) and Master Clear (MCLR). This allows customers to manufacture boards with unprogrammed devices and then program the Digital Signal Controller (DSC) just before shipping the product. This also allows the most recent firmware or a custom firmware to be programmed.

RTSP is accomplished using TBLRD (Table Read) and TBLWT (Table Write) instructions. With RTSP, the user application can write program memory data, either in blocks or ‘rows’ of 64 instructions (192 bytes) at a time, or a single program memory word, and erase program memory in blocks or ‘pages’ of 512 instructions (1536 bytes) at a time.

5.1 Table Instructions and Flash Programming

Regardless of the method used, all programming of Flash memory is done with the Table Read and Table Write instructions. These allow direct read and write access to the program memory space from the data memory while the device is in normal operating mode. The 24-bit target address in the program memory is formed using bits<7:0> of the TBLPAG register and the Effective Address (EA) from a W register specified in the table instruction, as shown in Figure 5-1.

The TBLRDL and the TBLWTL instructions are used to read or write to bits<15:0> of program memory. TBLRDL and TBLWTL can access program memory in both Word and Byte modes.

The TBLRDH and TBLWTH instructions are used to read or write to bits<23:16> of program memory. TBLRDH and TBLWTH can also access program memory in Word or Byte mode.

FIGURE 5-1: ADDRESSING FOR TABLE REGISTERS



5.2 RTSP Operation

The dsPIC33FJ32GS406/606/608/610 and dsPIC33FJ64GS406/606/608/610 Flash program memory array is organized into rows of 64 instructions or 192 bytes. RTSP allows the user application to erase a page of memory, which consists of eight rows (512 instructions) at a time, and to program one row or one word at a time. Table 27-12 shows typical erase and programming times. The 8-row erase pages and single row write rows are edge-aligned from the beginning of program memory, on boundaries of 1536 bytes and 192 bytes, respectively.

The program memory implements holding buffers that can contain 64 instructions of programming data. Prior to the actual programming operation, the write data must be loaded into the buffers sequentially. The instruction words loaded must always be from a group of 64 boundary.

The basic sequence for RTSP programming is to set up a Table Pointer, then do a series of TBLWT instructions to load the buffers. Programming is performed by setting the control bits in the NVMCON register. A total of 64 TBLWTL and TBLWTH instructions are required to load the instructions.

All of the Table Write operations are single-word writes (two instruction cycles) because only the buffers are written. A programming cycle is required for programming each row.

5.3 Programming Operations

A complete programming sequence is necessary for programming or erasing the internal Flash in RTSP mode. The processor stalls (waits) until the programming operation is finished.

The programming time depends on the FRC accuracy (see Table 27-20) and the value of the FRC Oscillator Tuning register (see Register 9-4). Use the following formula to calculate the minimum and maximum values for the Row Write Time, Page Erase Time and Word Write Cycle Time parameters (see Table 27-12).

EQUATION 5-1: PROGRAMMING TIME

$$T = \frac{11064 \text{ Cycles}}{7.37 \text{ MHz} \times (\text{FRC Accuracy})\% \times (\text{FRC Tuning})\%}$$

For example, if the device is operating at +125°C, the FRC accuracy will be ±2%. If the TUN<5:0> bits (see Register 9-4) are set to 0b000000, the minimum row write time is equal to Equation 5-2.

EQUATION 5-2: MINIMUM ROW WRITE TIME

$$T_{RW} = \frac{11064 \text{ Cycles}}{7.37 \text{ MHz} \times (1 + 0.02) \times (1 - 0.00375)} = 1.477 \text{ ms}$$

The maximum row write time is equal to Equation 5-3.

EQUATION 5-3: MAXIMUM ROW WRITE TIME

$$T_{RW} = \frac{11064 \text{ Cycles}}{7.37 \text{ MHz} \times (1 - 0.02) \times (1 - 0.00375)} = 1.537 \text{ ms}$$

Setting the WR bit (NVMCON<15>) starts the operation, and the WR bit is automatically cleared when the operation is finished.

5.4 Control Registers

Two SFRs are used to read and write the program Flash memory: NVMCON and NVMKEY.

The NVMCON register (Register 5-1) controls which blocks are to be erased, which memory type is to be programmed and the start of the programming cycle.

NVMKEY is a write-only register that is used for write protection. To start a programming or erase sequence, the user application must consecutively write 0x55 and 0xAA to the NVMKEY register. Refer to Section 5.3 “Programming Operations” for further details.

dsPIC33FJ32GS406/606/608/610 and dsPIC33FJ64GS406/606/608/610

REGISTER 5-1: NVMCON: FLASH MEMORY CONTROL REGISTER

| | | | | | | | |
|-----------------------|----------------------|----------------------|-----|-----|-----|-----|-------|
| R/SO-0 ⁽¹⁾ | R/W-0 ⁽¹⁾ | R/W-0 ⁽¹⁾ | U-0 | U-0 | U-0 | U-0 | U-0 |
| WR | WREN | WRERR | — | — | — | — | — |
| bit 15 | | | | | | | bit 8 |

| | | | | | | | |
|-------|----------------------|-----|-----|---------------------------|----------------------|----------------------|----------------------|
| U-0 | R/W-0 ⁽¹⁾ | U-0 | U-0 | R/W-0 ⁽¹⁾ | R/W-0 ⁽¹⁾ | R/W-0 ⁽¹⁾ | R/W-0 ⁽¹⁾ |
| — | ERASE | — | — | NVMOP<3:0> ⁽²⁾ | | | |
| bit 7 | | | | | | | bit 0 |

| | |
|-------------------|------------------------------------|
| Legend: | SO = Settable Only bit |
| R = Readable bit | W = Writable bit |
| -n = Value at POR | '1' = Bit is set |
| | U = Unimplemented bit, read as '0' |
| | '0' = Bit is cleared |
| | x = Bit is unknown |

- bit 15 **WR:** Write Control bit⁽¹⁾
 1 = Initiates a Flash memory program or erase operation; the operation is self-timed and the bit is cleared by hardware once operation is complete
 0 = Program or erase operation is complete and inactive
- bit 14 **WREN:** Write Enable bit⁽¹⁾
 1 = Enables Flash program/erase operations
 0 = Inhibits Flash program/erase operations
- bit 13 **WRERR:** Write Sequence Error Flag bit⁽¹⁾
 1 = An improper program or erase sequence attempt or termination has occurred (bit is set automatically on any set attempt of the WR bit)
 0 = The program or erase operation completed normally
- bit 12-7 **Unimplemented:** Read as '0'
- bit 6 **ERASE:** Erase/Program Enable bit⁽¹⁾
 1 = Performs the erase operation specified by NVMOP<3:0> on the next WR command
 0 = Performs the program operation specified by NVMOP<3:0> on the next WR command
- bit 5-4 **Unimplemented:** Read as '0'
- bit 3-0 **NVMOP<3:0>:** NVM Operation Select bits^(1,2)
If ERASE = 1:
 1111 = Memory bulk erase operation
 1101 = Erases General Segment
 0011 = No operation
 0010 = Memory page erase operation
 0001 = No operation
 0000 = Erases a single Configuration register byte
If ERASE = 0:
 1111 = No operation
 1101 = No operation
 0011 = Memory word program operation
 0010 = No operation
 0001 = Memory row program operation
 0000 = Programs a single Configuration register byte

- Note 1:** These bits can only be reset on a Power-on Reset.
Note 2: All other combinations of NVMOP<3:0> are unimplemented.

dsPIC33FJ32GS406/606/608/610 and dsPIC33FJ64GS406/606/608/610

REGISTER 5-2: NVMKEY: NONVOLATILE MEMORY KEY REGISTER

| | | | | | | | |
|--------|-----|-----|-----|-----|-----|-----|-------|
| U-0 | U-0 | U-0 | U-0 | U-0 | U-0 | U-0 | U-0 |
| — | — | — | — | — | — | — | — |
| bit 15 | | | | | | | bit 8 |

| | | | | | | | |
|-------------|-----|-----|-----|-----|-----|-----|-------|
| W-0 | W-0 | W-0 | W-0 | W-0 | W-0 | W-0 | W-0 |
| NVMKEY<7:0> | | | | | | | |
| bit 7 | | | | | | | bit 0 |

Legend:

R = Readable bit W = Writable bit U = Unimplemented bit, read as '0'
 -n = Value at POR '1' = Bit is set '0' = Bit is cleared x = Bit is unknown

bit 15-8 **Unimplemented:** Read as '0'
 bit 7-0 **NVMKEY<7:0>:** Key Register bits (write-only)

5.4.1 PROGRAMMING ALGORITHM FOR FLASH PROGRAM MEMORY

One row of program Flash memory can be programmed at a time. To achieve this, it is necessary to erase the 8-row erase page that contains the desired row. The general process is:

1. Read eight rows of program memory (512 instructions) and store in data RAM.
2. Update the program data in RAM with the desired new data.
3. Erase the block (see [Example 5-1](#)):
 - a) Set the NVMOPx bits (NVMCON<3:0>) to '0010' to configure for block erase. Set the ERASE (NVMCON<6>) and WREN (NVMCON<14>) bits.
 - b) Write the starting address of the page to be erased into the TBLPAG and W registers.
 - c) Write 0x55 to NVMKEY.
 - d) Write 0xAA to NVMKEY.
 - e) Set the WR bit (NVMCON<15>). The erase cycle begins and the CPU stalls for the duration of the erase cycle. When the erase is done, the WR bit is cleared automatically.

4. Write the first 64 instructions from data RAM into the program memory buffers (see [Example 5-2](#)).
5. Write the program block to Flash memory:
 - a) Set the NVMOPx bits to '0001' to configure for row programming. Clear the ERASE bit and set the WREN bit.
 - b) Write 0x55 to NVMKEY.
 - c) Write 0xAA to NVMKEY.
 - d) Set the WR bit. The programming cycle begins and the CPU stalls for the duration of the write cycle. When the write to Flash memory is done, the WR bit is cleared automatically.
6. Repeat Steps 4 and 5, using the next available 64 instructions from the block in data RAM by incrementing the value in TBLPAG, until all 512 instructions are written back to Flash memory.

For protection against accidental operations, the write initiate sequence for NVMKEY must be used to allow any erase or program operation to proceed. After the programming command has been executed, the user application must wait for the programming time until programming is complete. The two instructions following the start of the programming sequence should be NOPs, as shown in [Example 5-3](#).

EXAMPLE 5-1: ERASING A PROGRAM MEMORY PAGE

```

; Set up NVMCON for block erase operation
MOV    #0x4042, W0                ;
MOV    W0, NVMCON                ; Initialize NVMCON
; Init pointer to row to be ERASED
MOV    #tblpage(PROG_ADDR), W0   ;
MOV    W0, TBLPAG                ; Initialize PM Page Boundary SFR
MOV    #tbloffset(PROG_ADDR), W0 ; Initialize in-page EA[15:0] pointer
TBLWTL W0, [W0]                  ; Set base address of erase block
DISI   #5                        ; Block all interrupts with priority <7
                                           ; for next 5 instructions

MOV    #0x55, W0
MOV    W0, NVMKEY                ; Write the 55 key
MOV    #0xAA, W1
MOV    W1, NVMKEY                ; Write the AA key
BSET   NVMCON, #WR               ; Start the erase sequence
NOP
NOP                               ; Insert two NOPs after the erase
                                           ; command is asserted
    
```

EXAMPLE 5-2: LOADING THE WRITE BUFFERS

```
; Set up NVMCON for row programming operations
MOV    #0x4001, W0          ;
MOV    W0, NVMCON          ; Initialize NVMCON
; Set up a pointer to the first program memory location to be written
; program memory selected, and writes enabled
MOV    #0x0000, W0          ;
MOV    W0, TBLPAG          ; Initialize PM Page Boundary SFR
MOV    #0x6000, W0          ; An example program memory address
; Perform the TBLWT instructions to write the latches
; 0th_program_word
MOV    #LOW_WORD_0, W2     ;
MOV    #HIGH_BYTE_0, W3   ;
TBLWTL W2, [W0]           ; Write PM low word into program latch
TBLWTH W3, [W0++]        ; Write PM high byte into program latch
; 1st_program_word
MOV    #LOW_WORD_1, W2     ;
MOV    #HIGH_BYTE_1, W3   ;
TBLWTL W2, [W0]           ; Write PM low word into program latch
TBLWTH W3, [W0++]        ; Write PM high byte into program latch
; 2nd_program_word
MOV    #LOW_WORD_2, W2     ;
MOV    #HIGH_BYTE_2, W3   ;
TBLWTL W2, [W0]           ; Write PM low word into program latch
TBLWTH W3, [W0++]        ; Write PM high byte into program latch
.
.
.
; 63rd_program_word
MOV    #LOW_WORD_31, W2    ;
MOV    #HIGH_BYTE_31, W3  ;
TBLWTL W2, [W0]           ; Write PM low word into program latch
TBLWTH W3, [W0++]        ; Write PM high byte into program latch
```

EXAMPLE 5-3: INITIATING A PROGRAMMING SEQUENCE

```
DISI   #5                  ; Block all interrupts with priority <7
                          ; for next 5 instructions
MOV    #0x55, W0           ;
MOV    W0, NVMKEY          ; Write the 55 key
MOV    #0xAA, W1           ;
MOV    W1, NVMKEY          ; Write the AA key
BSET   NVMCON, #WR         ; Start the erase sequence
NOP    ; Insert two NOPs after the
NOP    ; erase command is asserted
```

6.0 RESETS

Note 1: This data sheet summarizes the features of the dsPIC33FJ32GS406/606/608/610 and dsPIC33FJ64GS406/606/608/610 families of devices. It is not intended to be a comprehensive reference source. To complement the information in this data sheet, refer to **Section 8. “Reset”** (DS70192) in the “dsPIC33F/PIC24H Family Reference Manual”, which is available from the Microchip web site (www.microchip.com).

2: Some registers and associated bits described in this section may not be available on all devices. Refer to **Section 4.0 “Memory Organization”** in this data sheet for device-specific register and bit information.

The Reset module combines all Reset sources and controls the device Master Reset Signal, $\overline{\text{SYSRST}}$. The following is a list of device Reset sources:

- POR: Power-on Reset
- BOR: Brown-out Reset
- $\overline{\text{MCLR}}$: Master Clear Pin Reset
- SWR: Software RESET Instruction
- WDTO: Watchdog Timer Reset
- TRAPR: Trap Conflict Reset
- IOPUWR: Illegal Condition Device Reset
 - Illegal Opcode Reset
 - Uninitialized W Register Reset
 - Security Reset

A simplified block diagram of the Reset module is shown in [Figure 6-1](#).

Any active source of Reset will make the $\overline{\text{SYSRST}}$ signal active. On system Reset, some of the registers associated with the CPU and peripherals are forced to a known Reset state and some are unaffected.

Note: Refer to the specific peripheral section or **Section 3.0 “CPU”** of this data sheet for register Reset states.

All types of device Reset sets a corresponding status bit in the RCON register to indicate the type of Reset (see [Register 6-1](#)).

A POR clears all the bits, except for the POR bit ($\text{RCON}\langle 0 \rangle$), that are set. The user application can set or clear any bit at any time during code execution. The RCON bits only serve as status bits. Setting a particular Reset status bit in software does not cause a device Reset to occur.

The RCON register also has other bits associated with the Watchdog Timer and device power-saving states. The function of these bits is discussed in other sections of this manual.

Note: The status bits in the RCON register should be cleared after they are read so that the next RCON register value after a device Reset is meaningful.

FIGURE 6-1: RESET SYSTEM BLOCK DIAGRAM

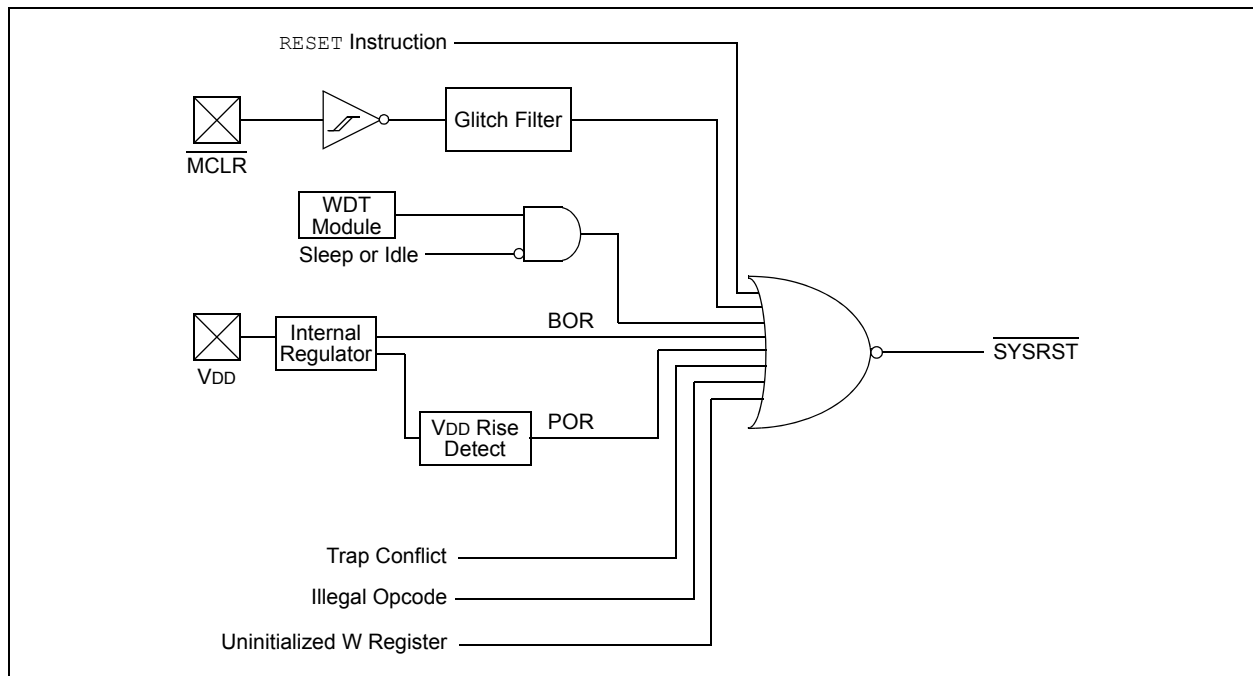

dsPIC33FJ32GS406/606/608/610 and dsPIC33FJ64GS406/606/608/610

REGISTER 6-1: RCON: RESET CONTROL REGISTER⁽¹⁾

| | | | | | | | |
|--------|--------|-----|-----|-----|-----|-----|-------|
| R/W-0 | R/W-0 | U-0 | U-0 | U-0 | U-0 | U-0 | R/W-0 |
| TRAPR | IOPUWR | — | — | — | — | — | VREGS |
| bit 15 | | | | | | | bit 8 |

| | | | | | | | |
|-------|-------|-----------------------|-------|-------|-------|-------|-------|
| R/W-0 | R/W-0 | R/W-0 | R/W-0 | R/W-0 | R/W-0 | R/W-1 | R/W-1 |
| EXTR | SWR | SWDTEN ⁽²⁾ | WDTO | SLEEP | IDLE | BOR | POR |
| bit 7 | | | | | | | bit 0 |

Legend:

| | | |
|-------------------|------------------|------------------------------------|
| R = Readable bit | W = Writable bit | U = Unimplemented bit, read as '0' |
| -n = Value at POR | '1' = Bit is set | '0' = Bit is cleared |
| | | x = Bit is unknown |

- bit 15 **TRAPR:** Trap Reset Flag bit
 1 = A Trap Conflict Reset has occurred
 0 = A Trap Conflict Reset has not occurred
- bit 14 **IOPUWR:** Illegal Opcode or Uninitialized W Access Reset Flag bit
 1 = An illegal opcode detection, an illegal address mode or uninitialized W register used as an Address Pointer caused a Reset
 0 = An illegal opcode or uninitialized W Reset has not occurred
- bit 13-9 **Unimplemented:** Read as '0'
- bit 8 **VREGS:** Voltage Regulator Standby During Sleep bit
 1 = Voltage regulator is active during Sleep
 0 = Voltage regulator goes into Standby mode during Sleep
- bit 7 **EXTR:** External Reset Pin ($\overline{\text{MCLR}}$) bit
 1 = A Master Clear (pin) Reset has occurred
 0 = A Master Clear (pin) Reset has not occurred
- bit 6 **SWR:** Software Reset Flag (Instruction) bit
 1 = A RESET instruction has been executed
 0 = A RESET instruction has not been executed
- bit 5 **SWDTEN:** Software Enable/Disable of WDT bit⁽²⁾
 1 = WDT is enabled
 0 = WDT is disabled
- bit 4 **WDTO:** Watchdog Timer Time-out Flag bit
 1 = WDT time-out has occurred
 0 = WDT time-out has not occurred
- bit 3 **SLEEP:** Wake-up from Sleep Flag bit
 1 = Device has been in Sleep mode
 0 = Device has not been in Sleep mode
- bit 2 **IDLE:** Wake-up from Idle Flag bit
 1 = Device has been in Idle mode
 0 = Device has not been in Idle mode
- bit 1 **BOR:** Brown-out Reset Flag bit
 1 = A Brown-out Reset has occurred
 0 = A Brown-out Reset has not occurred
- bit 0 **POR:** Power-on Reset Flag bit
 1 = A Power-on Reset has occurred
 0 = A Power-on Reset has not occurred

Note 1: All of the Reset status bits can be set or cleared in software. Setting one of these bits in software does not cause a device Reset.

2: If the FWDTEN Configuration bit is '1' (unprogrammed), the WDT is always enabled, regardless of the SWDTEN bit setting.

6.1 System Reset

The dsPIC33FJ32GS406/606/608/610 and dsPIC33FJ64GS406/606/608/610 families of devices have two types of Reset:

- Cold Reset
- Warm Reset

A Cold Reset is the result of a Power-on Reset (POR) or a Brown-out Reset (BOR). On a Cold Reset, the FNOSC_x Configuration bits in the FOSC Configuration register select the device clock source.

A Warm Reset is the result of all the other Reset sources, including the RESET instruction. On Warm Reset, the device will continue to operate from the current clock source as indicated by the Current Oscillator Selection (COSC<2:0>) bits in the Oscillator Control (OSCCON<14:12>) register.

The device is kept in a Reset state until the system power supplies have stabilized at appropriate levels and the oscillator clock is ready. The sequence in which this occurs is described in [Figure 6-2](#).

TABLE 6-1: OSCILLATOR DELAY

| Oscillator Mode | Oscillator Start-up Delay | Oscillator Start-up Timer | PLL Lock Time | Total Delay |
|------------------------|----------------------------------|---------------------------------|----------------------------------|---|
| FRC, FRCDIV16, FRCDIVN | T _{OSCD} ⁽¹⁾ | — | — | T _{OSCD} ⁽¹⁾ |
| FRCPLL | T _{OSCD} ⁽¹⁾ | — | T _{LOCK} ⁽³⁾ | T _{OSCD} + T _{LOCK} ^(1,3) |
| XT | T _{OSCD} ⁽¹⁾ | T _{OST} ⁽²⁾ | — | T _{OSCD} + T _{OST} ^(1,2) |
| HS | T _{OSCD} ⁽¹⁾ | T _{OST} ⁽²⁾ | — | T _{OSCD} + T _{OST} ^(1,2) |
| EC | — | — | — | — |
| XTPLL | T _{OSCD} ⁽¹⁾ | T _{OST} ⁽²⁾ | T _{LOCK} ⁽³⁾ | T _{OSCD} + T _{OST} + T _{LOCK} ^(1,2,3) |
| HSPLL | T _{OSCD} ⁽¹⁾ | T _{OST} ⁽²⁾ | T _{LOCK} ⁽³⁾ | T _{OSCD} + T _{OST} + T _{LOCK} ^(1,2,3) |
| ECPLL | — | — | T _{LOCK} ⁽³⁾ | T _{LOCK} ⁽³⁾ |
| LPRC | T _{OSCD} ⁽¹⁾ | — | — | T _{OSCD} ⁽¹⁾ |

Note 1: T_{OSCD} = Oscillator start-up delay (1.1 μs max. for FRC, 70 μs max. for LPRC). Crystal oscillator start-up times vary with crystal characteristics, load capacitance, etc.

2: T_{OST} = Oscillator Start-up Timer (OST) delay (1024 oscillator clock period). For example, T_{OST} = 102.4 μs for a 10 MHz crystal and T_{OST} = 32 ms for a 32 kHz crystal.

3: T_{LOCK} = PLL lock time (1.5 ms nominal) if PLL is enabled.

FIGURE 6-2: SYSTEM RESET TIMING



Note: When the device exits the Reset condition (begins normal operation), the device operating parameters (voltage, frequency, temperature, etc.) must be within their operating ranges; otherwise, the device may not function correctly. The user application must ensure that the delay between the time power is first applied, and the time $SYSRST$ becomes inactive, is long enough to get all operating parameters within specification.

6.2 Power-on Reset (POR)

A Power-on Reset (POR) circuit ensures the device is reset from power-on. The POR circuit is active until VDD crosses the VPOR threshold and the delay, TPOR, has elapsed. The delay, TPOR, ensures the internal device bias circuits become stable.

The device supply voltage characteristics must meet the specified starting voltage and rise rate requirements to generate the POR. Refer to [Section 27.0 “Electrical Characteristics”](#) for details.

The Power-on Reset (POR) status bit in the Reset Control (RCON<0>) register is set to indicate the Power-on Reset.

6.3 Brown-out Reset (BOR) and Power-up Timer (PWRT)

The on-chip regulator has a Brown-out Reset (BOR) circuit that resets the device when the VDD is too low ($V_{DD} < V_{BOR}$) for proper device operation. The BOR circuit keeps the device in Reset until VDD crosses the

V_{BOR} threshold and the delay, TBOR, has elapsed. The delay, TBOR, ensures the voltage regulator output becomes stable.

The Brown-out Reset (BOR) status bit in the Reset Control (RCON<1>) register is set to indicate the Brown-out Reset.

The device will not run at full speed after a BOR as the VDD should rise to acceptable levels for full-speed operation. The PWRT provides power-up time delay (TPWRT) to ensure that the system power supplies have stabilized at the appropriate levels for full-speed operation before the SYSRST is released.

The Power-up Timer delay (TPWRT) is programmed by the Power-on Reset Timer Value Select (FPWRT<2:0>) bits in the FPOR Configuration (FPOR<2:0>) register, which provides eight settings (from 0 ms to 128 ms). Refer to [Section 24.0 “Special Features”](#) for further details.

[Figure 6-3](#) shows the typical brown-out scenarios. The Reset delay (TBOR + TPWRT) is initiated each time VDD rises above the V_{BOR} trip point

FIGURE 6-3: BROWN-OUT SITUATIONS



6.4 External Reset (EXTR)

The External Reset is generated by driving the $\overline{\text{MCLR}}$ pin low. The $\overline{\text{MCLR}}$ pin is a Schmitt Trigger input with an additional glitch filter. Reset pulses that are longer than the minimum pulse width will generate a Reset. Refer to [Section 27.0 “Electrical Characteristics”](#) for minimum pulse width specifications. The External Reset ($\overline{\text{MCLR}}$) pin (EXTR) bit in the Reset Control (RCON) register is set to indicate the $\overline{\text{MCLR}}$ Reset.

6.4.1 EXTERNAL SUPERVISORY CIRCUIT

Many systems have external supervisory circuits that generate Reset signals to reset multiple devices in the system. This external Reset signal can be directly connected to the $\overline{\text{MCLR}}$ pin to reset the device when the rest of system is reset.

6.4.2 INTERNAL SUPERVISORY CIRCUIT

When using the internal power supervisory circuit to reset the device, the External Reset pin ($\overline{\text{MCLR}}$) should be tied directly or resistively to VDD. In this case, the $\overline{\text{MCLR}}$ pin will not be used to generate a Reset. The External Reset pin ($\overline{\text{MCLR}}$) does not have an internal pull-up and must not be left unconnected.

6.5 Software RESET Instruction (SWR)

Whenever the RESET instruction is executed, the device will assert $\overline{\text{SYSRST}}$, placing the device in a special Reset state. This Reset state will not re-initialize the clock. The clock source in effect prior to the RESET instruction will remain. $\overline{\text{SYSRST}}$ is released at the next instruction cycle and the Reset vector fetch will commence.

The Software Reset (SWR) flag (instruction) in the Reset Control (RCON<6>) register is set to indicate the Software Reset.

6.6 Watchdog Timer Time-out Reset (WDTO)

Whenever a Watchdog Timer Time-out Reset occurs, the device will asynchronously assert $\overline{\text{SYSRST}}$. The clock source will remain unchanged. A WDT time-out during Sleep or Idle mode will wake-up the processor, but will not reset the processor.

The Watchdog Timer Time-out (WDTO) flag in the Reset Control (RCON<4>) register is set to indicate the Watchdog Timer Reset. Refer to [Section 24.4 “Watchdog Timer \(WDT\)”](#) for more information on the Watchdog Timer Reset.

6.7 Trap Conflict Reset

If a lower priority hard trap occurs while a higher priority trap is being processed, a hard Trap Conflict Reset occurs. The hard traps include exceptions of Priority Level 13 through Level 15, inclusive. The address error (Level 13) and oscillator error (Level 14) traps fall into this category.

The Trap Reset (TRAPR) flag in the Reset Control (RCON<15>) register is set to indicate the Trap Conflict Reset. Refer to [Section 7.0 “Interrupt Controller”](#) for more information on Trap Conflict Resets.

6.8 Illegal Condition Device Reset

An illegal condition device Reset occurs due to the following sources:

- Illegal Opcode Reset
- Uninitialized W Register Reset
- Security Reset

The Illegal Opcode or Uninitialized W Access Reset (IOPUWR) flag in the Reset Control (RCON<14>) register is set to indicate the illegal condition device Reset.

6.8.1 ILLEGAL OPCODE RESET

A device Reset is generated if the device attempts to execute an illegal opcode value that is fetched from program memory.

The Illegal Opcode Reset function can prevent the device from executing program memory sections that are used to store constant data. To take advantage of the Illegal Opcode Reset, use only the lower 16 bits of each program memory section to store the data values. The upper 8 bits should be programmed with 3Fh, which is an illegal opcode value.

6.8.2 UNINITIALIZED W REGISTER RESET

Any attempt to use the uninitialized W register as an Address Pointer will reset the device. The W register array (with the exception of W15) is cleared during all Resets and is considered uninitialized until written to.

6.8.3 SECURITY RESET

If a Program Flow Change (PFC) or Vector Flow Change (VFC) targets a restricted location in a protected segment (boot and secure segment), that operation will cause a Security Reset.

The PFC occurs when the Program Counter is reloaded as a result of a call, jump, computed jump, return, return from subroutine or other form of branch instruction.

The VFC occurs when the Program Counter is reloaded with an interrupt or trap vector.

Refer to [Section 24.8 “Code Protection and CodeGuard™ Security”](#) for more information on Security Reset.

6.9 Using the RCON Status Bits

Table 6-2 provides a summary of the Reset flag bit operation.

The user application can read the Reset Control (RCON) register after any device Reset to determine the cause of the Reset.

Note: The status bits in the RCON register should be cleared after they are read so that the next RCON register value after a device Reset will be meaningful.

TABLE 6-2: RESET FLAG BIT OPERATION

| Flag Bit | Set by: | Cleared by: |
|-------------------------|---|---|
| TRAPR (RCON<15>) | Trap conflict event | POR, BOR |
| IOPWR (RCON<14>) | Illegal opcode or uninitialized W register access or Security Reset | POR, BOR |
| EXTR (RCON<7>) | MCLR Reset | POR |
| SWR (RCON<6>) | RESET instruction | POR, BOR |
| WDTO (RCON<4>) | WDT time-out | PWRSV instruction, CLRWDT instruction, POR, BOR |
| SLEEP (RCON<3>) | PWRSV #SLEEP instruction | POR, BOR |
| IDLE (RCON<2>) | PWRSV #IDLE instruction | POR, BOR |
| BOR (RCON<1>) | POR, BOR | — |
| POR (RCON<0>) | POR | — |

Note: All Reset flag bits can be set or cleared by user software.

NOTES:

7.0 INTERRUPT CONTROLLER

Note 1: This data sheet summarizes the features of the dsPIC33FJ32GS406/606/608/610 and dsPIC33FJ64GS406/606/608/610 families of devices. It is not intended to be a comprehensive reference source. To complement the information in this data sheet, refer to **Section 47. “Interrupts (Part V)”** (DS70597) in the “*dsPIC33F/PIC24H Family Reference Manual*”, which is available from the Microchip web site (www.microchip.com).

2: Some registers and associated bits described in this section may not be available on all devices. Refer to **Section 4.0 “Memory Organization”** in this data sheet for device-specific register and bit information.

The dsPIC33FJ32GS406/606/608/610 and dsPIC33FJ64GS406/606/608/610 interrupt controller reduces the numerous peripheral interrupt request signals to a single interrupt request signal to the dsPIC33FJ32GS406/606/608/610 and dsPIC33FJ64GS406/606/608/610 CPU. It has the following features:

- Up to Eight Processor Exceptions and Software Traps
- Seven User-Selectable Priority Levels
- Interrupt Vector Table (IVT) with up to 118 Vectors
- A Unique Vector for each Interrupt or Exception Source
- Fixed Priority within a Specified User Priority Level
- Alternate Interrupt Vector Table (AIVT) for Debug Support
- Fixed Interrupt Entry and Return Latencies

7.1 Interrupt Vector Table

The Interrupt Vector Table (IVT) is shown in [Figure 7-1](#). The IVT resides in program memory, starting at location 000004h. The IVT contains 126 vectors, consisting of eight nonmaskable trap vectors, plus up to 118 sources of interrupt. In general, each interrupt source has its own vector. Each interrupt vector contains a 24-bit-wide address. The value programmed into each interrupt vector location is the starting address of the associated Interrupt Service Routine (ISR).

Interrupt vectors are prioritized in terms of their natural priority. This priority is linked to their position in the vector table. Lower addresses generally have a higher natural priority. For example, the interrupt associated with Vector 0 will take priority over interrupts at any other vector address.

The dsPIC33FJ32GS406/606/608/610 and dsPIC33FJ64GS406/606/608/610 devices implement up to 71 unique interrupts and five non-maskable traps. These are summarized in [Table 7-1](#).

7.1.1 ALTERNATE INTERRUPT VECTOR TABLE

The Alternate Interrupt Vector Table (AIVT) is located after the IVT, as shown in [Figure 7-1](#). Access to the AIVT is provided by the ALTIVT control bit (INTCON2<15>). If the ALTIVT bit is set, all interrupt and exception processes use the alternate vectors instead of the default vectors. The alternate vectors are organized in the same manner as the default vectors.

The AIVT supports debugging by providing a means to switch between an application and a support environment without requiring the interrupt vectors to be reprogrammed. This feature also enables switching between applications for evaluation of different software algorithms at run time. If the AIVT is not needed, the AIVT should be programmed with the same addresses used in the IVT.

7.2 Reset Sequence

A device Reset is not a true exception because the interrupt controller is not involved in the Reset process. The dsPIC33FJ32GS406/606/608/610 and dsPIC33FJ64GS406/606/608/610 device clears its registers in response to a Reset, which forces the PC to zero. The Digital Signal Controller (DSC) then begins program execution at location, 0x000000. A `GOTO` instruction at the Reset address can redirect program execution to the appropriate start-up routine.

Note: Any unimplemented or unused vector locations in the IVT and AIVT should be programmed with the address of a default interrupt handler routine that contains a `RESET` instruction.

FIGURE 7-1: dsPIC33FJ32GS406/606/608/610 and dsPIC33FJ64GS406/606/608/610 INTERRUPT VECTOR TABLE



Note 1: See [Table 7-1](#) for the list of implemented interrupt vectors.

TABLE 7-1: INTERRUPT VECTORS

| Vector Number | Interrupt Request (IQR) | IVT Address | AIVT Address | Interrupt Source |
|--------------------------------|-------------------------|-----------------------|-----------------------|--|
| Highest Natural Order Priority | | | | |
| 8 | 0 | 0x000014 | 0x000114 | INT0 – External Interrupt 0 |
| 9 | 1 | 0x000016 | 0x000116 | IC1 – Input Capture 1 |
| 10 | 2 | 0x000018 | 0x000118 | OC1 – Output Compare 1 |
| 11 | 3 | 0x00001A | 0x00011A | T1 – Timer1 |
| 12 | 4 | 0x00001C | 0x00011C | DMA0 – DMA Channel 0 |
| 13 | 5 | 0x00001E | 0x00011E | IC2 – Input Capture 2 |
| 14 | 6 | 0x000020 | 0x000120 | OC2 – Output Compare 2 |
| 15 | 7 | 0x000022 | 0x000122 | T2 – Timer2 |
| 16 | 8 | 0x000024 | 0x000124 | T3 – Timer3 |
| 17 | 9 | 0x000026 | 0x000126 | SPI1E – SPI1 Fault |
| 18 | 10 | 0x000028 | 0x000128 | SPI1 – SPI1 Transfer Done |
| 19 | 11 | 0x00002A | 0x00012A | U1RX – UART1 Receiver |
| 20 | 12 | 0x00002C | 0x00012C | U1TX – UART1 Transmitter |
| 21 | 13 | 0x00002E | 0x00012E | ADC – ADC Group Convert Done |
| 22 | 14 | 0x000030 | 0x000130 | DMA1 – DMA Channel 1 |
| 23 | 15 | 0x000032 | 0x000132 | Reserved |
| 24 | 16 | 0x000034 | 0x000134 | SI2C1 – I2C1 Slave Event |
| 25 | 17 | 0x000036 | 0x000136 | MI2C1 – I2C1 Master Event |
| 26 | 18 | 0x000038 | 0x000138 | CMP1 – Analog Comparator 1 Interrupt |
| 27 | 19 | 0x00003A | 0x00013A | CN – Input Change Notification Interrupt |
| 28 | 20 | 0x00003C | 0x00013C | INT1 – External Interrupt 1 |
| 29-31 | 21-23 | 0x00003E- 0x000042 | 0x00013E- 0x000142 | Reserved |
| 32 | 24 | 0x000044 | 0x000144 | DMA2 – DMA Channel 2 |
| 33 | 25 | 0x000046 | 0x000146 | OC3 – Output Compare 3 |
| 34 | 26 | 0x000048 | 0x000148 | OC4 – Output Compare 4 |
| 35 | 27 | 0x00004A | 0x00014A | T4 – Timer4 |
| 36 | 28 | 0x00004C | 0x00014C | T5 – Timer5 |
| 37 | 29 | 0x00004E | 0x00014E | INT2 – External Interrupt 2 |
| 38 | 30 | 0x000050 | 0x000150 | U2RX – UART2 Receiver |
| 39 | 31 | 0x000052 | 0x000152 | U2TX – UART2 Transmitter |
| 40 | 32 | 0x000054 | 0x000154 | SPI2E – SPI2 Error |
| 41 | 33 | 0x000056 | 0x000156 | SPI2 – SPI2 Transfer Done |
| 42 | 34 | 0x000058 | 0x000158 | C1RX – ECAN1 Receive Data Ready |
| 43 | 35 | 0x00005A | 0x00015A | C1 – ECAN1 Event |
| 44 | 36 | 0x00005C | 0x00015C | DMA3 – DMA Channel 3 |
| 45 | 37 | 0x00005E | 0x00015E | IC3 – Input Capture 3 |
| 46 | 38 | 0x000060 | 0x000160 | IC4 – Input Capture 4 |
| 47-56 | 39-48 | 0x000062- 0x000074 | 0x000162- 0x000174 | Reserved |
| 57 | 49 | 0x000076 | 0x000176 | SI2C2 – I2C2 Slave Events |
| 58 | 50 | 0x000078 | 0x000178 | MI2C2 – I2C2 Master Events |
| 59-60 | 51-52 | 0x00007A- 0x00007C | 0x00017A- 0x00017C | Reserved |
| 61 | 53 | 0x00007E | 0x00017E | INT3 – External Interrupt 3 |
| 62 | 54 | 0x000080 | 0x000180 | INT4 – External Interrupt 4 |

dsPIC33FJ32GS406/606/608/610 and dsPIC33FJ64GS406/606/608/610

TABLE 7-1: INTERRUPT VECTORS (CONTINUED)

| Vector Number | Interrupt Request (IQR) | IVT Address | AIVT Address | Interrupt Source |
|-------------------------------|-------------------------|-------------------|-------------------|------------------------------------|
| 63-64 | 55-56 | 0x000082-0x000084 | 0x000182-0x000184 | Reserved |
| 65 | 57 | 0x000086 | 0x000186 | PWM PSEM Special Event Match |
| 66 | 58 | 0x000088 | 0x000188 | QE1 – Position Counter Compare |
| 67-72 | 59-64 | 0x00008A-0x000094 | 0x00018A-0x000194 | Reserved |
| 73 | 65 | 0x000096 | 0x000196 | U1E – UART1 Error Interrupt |
| 74 | 66 | 0x000098 | 0x000198 | U2E – UART2 Error Interrupt |
| 75-77 | 67-69 | 0x00009A-0x00009E | 0x00019A-0x00019E | Reserved |
| 78 | 70 | 0x0000A0 | 0x0001A0 | C1TX – ECAN1 Transmit Data Request |
| 79 | 71 | 0x0000A2 | 0x0001A2 | Reserved |
| 80 | 72 | 0x0000A4 | 0x0001A4 | Reserved |
| 81 | 73 | 0x0000A6 | 0x0001A6 | PWM Secondary Special Event Match |
| 82 | 74 | 0x0000A8 | 0x0001A8 | Reserved |
| 83 | 75 | 0x0000AA | 0x0001AA | QE2 – Position Counter Compare |
| 84-88 | 76-80 | 0x0000AC-0x0000B4 | 0x0001AC-0x0001B4 | Reserved |
| 89 | 81 | 0x0000B6 | 0x0001B6 | ADC Pair 8 Conversion Done |
| 90 | 82 | 0x0000B8 | 0x0001B8 | ADC Pair 9 Conversion Done |
| 91 | 83 | 0x0000BA | 0x0001BA | ADC Pair 10 Conversion Done |
| 92 | 84 | 0x0000BC | 0x0001BC | ADC Pair 11 Conversion Done |
| 93 | 85 | 0x0000BE | 0x0001BE | ADC Pair 12 Conversion Done |
| 94-101 | 86-93 | 0x0000C0-0x0000CE | 0x0001C0-0x0001CE | Reserved |
| 102 | 94 | 0x0000D0 | 0x0001D0 | PWM1 – PWM1 Interrupt |
| 103 | 95 | 0x0000D2 | 0x0001D2 | PWM2 – PWM2 Interrupt |
| 104 | 96 | 0x0000D4 | 0x0001D4 | PWM3 – PWM3 Interrupt |
| 105 | 97 | 0x0000D6 | 0x0001D6 | PWM4 – PWM4 Interrupt |
| 106 | 98 | 0x0000D8 | 0x0001D8 | PWM5 – PWM5 Interrupt |
| 107 | 99 | 0x0000DA | 0x0001DA | PWM6 – PWM6 Interrupt |
| 108 | 100 | 0x0000DC | 0x0001DC | PWM7 – PWM7 Interrupt |
| 109 | 101 | 0x0000DE | 0x0001DE | PWM8 – PWM8 Interrupt |
| 110 | 102 | 0x0000E0 | 0x0001E0 | PWM9 – PWM9 Interrupt |
| 111 | 103 | 0x0000E2 | 0x0001E2 | CMP2 – Analog Comparator 2 |
| 112 | 104 | 0x0000E4 | 0x0001E4 | CMP3 – Analog Comparator 3 |
| 113 | 105 | 0x0000E6 | 0x0001E6 | CMP4 – Analog Comparator 4 |
| 114-117 | 106-109 | 0x0000E8-0x0000EE | 0x0001E8-0x0001EE | Reserved |
| 118 | 110 | 0x0000F0 | 0x0001F0 | ADC Pair 0 Convert Done |
| 119 | 111 | 0x0000F2 | 0x0001F2 | ADC Pair 1 Convert Done |
| 120 | 112 | 0x0000F4 | 0x0001F4 | ADC Pair 2 Convert Done |
| 121 | 113 | 0x0000F6 | 0x0001F6 | ADC Pair 3 Convert Done |
| 122 | 114 | 0x0000F8 | 0x0001F8 | ADC Pair 4 Convert Done |
| 123 | 115 | 0x0000FA | 0x0001FA | ADC Pair 5 Convert Done |
| 124 | 116 | 0x0000FC | 0x0001FC | ADC Pair 6 Convert Done |
| 125 | 117 | 0x0000FE | 0x0001FE | ADC Pair 7 Convert Done |
| Lowest Natural Order Priority | | | | |

7.3 Interrupt Control and Status Registers

The dsPIC33FJ32GS406/606/608/610 and dsPIC33FJ64GS406/606/608/610 devices implement 44 registers for the interrupt controller:

- INTCON1
- INTCON2
- IFSx
- IECx
- IPCx
- INTTREG

7.3.1 INTCON1 AND INTCON2

Global interrupt control functions are controlled from INTCON1 and INTCON2. INTCON1 contains the Interrupt Nesting Disable (NSTDIS) bit as well as the control and status flags for the processor trap sources. The INTCON2 register controls the external interrupt request signal behavior and the use of the Alternate Interrupt Vector Table.

7.3.2 IFSx

The IFSx registers maintain all of the interrupt request flags. Each source of interrupt has a status bit, which is set by the respective peripherals or external signal and is cleared via software.

7.3.3 IECx

The IECx registers maintain all of the interrupt enable bits. These control bits are used to individually enable interrupts from the peripherals or external signals.

7.3.4 IPCx

The IPCx registers are used to set the Interrupt Priority Level for each source of interrupt. Each user interrupt source can be assigned to one of eight priority levels.

7.3.5 INTTREG

The INTTREG register contains the associated interrupt vector number and the new CPU Interrupt Priority Level, which are latched into the Vector Number (VECNUM<6:0>) and Interrupt Level (ILR<3:0>) bit fields in the INTTREG register. The new Interrupt Priority Level is the priority of the pending interrupt.

The interrupt sources are assigned to the IFSx, IECx and IPCx registers in the same sequence that they are listed in [Table 7-1](#). For example, the INTO (External Interrupt 0) is shown as having vector number 8 and a natural order priority of 0. Thus, the INTOIF bit is found in IFS0<0>, the INTOIE bit is found in IEC0<0> and the INTOIP bits are found in the first position of IPC0 (IPC0<2:0>).

7.3.6 STATUS/CONTROL REGISTERS

Although they are not specifically part of the interrupt control hardware, two of the CPU Control registers contain bits that control interrupt functionality.

- The CPU STATUS Register, SR, contains the IPL<2:0> bits (SR<7:5>). These bits indicate the current CPU Interrupt Priority Level. The user can change the current CPU Priority Level by writing to the IPL bits.
- The CORCON register contains the IPL3 bit, which together with IPL<2:0>, indicates the current CPU Priority Level. IPL3 is a read-only bit so that trap events cannot be masked by the user software.

All Interrupt registers are described in [Register 7-1](#) through [Register 7-46](#) in the following pages.

dsPIC33FJ32GS406/606/608/610 and dsPIC33FJ64GS406/606/608/610

REGISTER 7-1: SR: CPU STATUS REGISTER⁽¹⁾

| | | | | | | | |
|--------|-----|-------|-------|-----|-------|-----|-------|
| R-0 | R-0 | R/C-0 | R/C-0 | R-0 | R/C-0 | R-0 | R/W-0 |
| OA | OB | SA | SB | OAB | SAB | DA | DC |
| bit 15 | | | | | | | bit 8 |

| | | | | | | | |
|----------------------|----------------------|----------------------|-----|-------|-------|-------|-------|
| R/W-0 ⁽³⁾ | R/W-0 ⁽³⁾ | R/W-0 ⁽³⁾ | R-0 | R/W-0 | R/W-0 | R/W-0 | R/W-0 |
| IPL2 ⁽²⁾ | IPL1 ⁽²⁾ | IPL0 ⁽²⁾ | RA | N | OV | Z | C |
| bit 7 | | | | | | | bit 0 |

| | |
|-------------------|------------------------------------|
| Legend: | C = Clearable bit |
| R = Readable bit | W = Writable bit |
| -n = Value at POR | '1' = Bit is set |
| | U = Unimplemented bit, read as '0' |
| | '0' = Bit is cleared |
| | x = Bit is unknown |

- bit 7-5 **IPL<2:0>**: CPU Interrupt Priority Level Status bits^(2,3)
- 111 = CPU Interrupt Priority Level is 7 (15), user interrupts are disabled
 - 110 = CPU Interrupt Priority Level is 6 (14)
 - 101 = CPU Interrupt Priority Level is 5 (13)
 - 100 = CPU Interrupt Priority Level is 4 (12)
 - 011 = CPU Interrupt Priority Level is 3 (11)
 - 010 = CPU Interrupt Priority Level is 2 (10)
 - 001 = CPU Interrupt Priority Level is 1 (9)
 - 000 = CPU Interrupt Priority Level is 0 (8)

- Note 1:** For complete register details, see [Register 3-1](#).
- 2:** The IPL<2:0> bits are concatenated with the IPL<3> bit (CORCON<3>) to form the CPU Interrupt Priority Level. The value in parentheses indicates the IPL if IPL<3> = 1. User interrupts are disabled when IPL<3> = 1.
- 3:** The IPL<2:0> Status bits are read-only when NSTDIS (INTCON1<15>) = 1.

REGISTER 7-2: CORCON: CORE CONTROL REGISTER⁽¹⁾

| | | | | | | | |
|--------|-----|-----|-------|-------|---------|-----|-------|
| U-0 | U-0 | U-0 | R/W-0 | R/W-0 | R-0 | R-0 | R-0 |
| — | — | — | US | EDT | DL<2:0> | | |
| bit 15 | | | | | | | bit 8 |

| | | | | | | | |
|-------|-------|-------|--------|---------------------|-------|-------|-------|
| R/W-0 | R/W-0 | R/W-1 | R/W-0 | R/C-0 | R/W-0 | R/W-0 | R/W-0 |
| SATA | SATB | SATDW | ACCSAT | IPL3 ⁽²⁾ | PSV | RND | IF |
| bit 7 | | | | | | | bit 0 |

| | |
|----------------------|------------------------------------|
| Legend: | C = Clearable bit |
| R = Readable bit | W = Writable bit |
| '0' = Bit is cleared | 'x' = Bit is unknown |
| | -n = Value at POR |
| | '1' = Bit is set |
| | U = Unimplemented bit, read as '0' |

- bit 3 **IPL3**: CPU Interrupt Priority Level Status bit⁽²⁾
- 1 = CPU Interrupt Priority Level is greater than 7
 - 0 = CPU Interrupt Priority Level is 7 or less

- Note 1:** For complete register details, see [Register 3-2](#).
- 2:** The IPL3 bit is concatenated with the IPL<2:0> bits (SR<7:5>) to form the CPU Interrupt Priority Level.

dsPIC33FJ32GS406/606/608/610 and dsPIC33FJ64GS406/606/608/610

REGISTER 7-3: INTCON1: INTERRUPT CONTROL REGISTER 1

| | | | | | | | |
|--------|--------|--------|---------|---------|-------|-------|-------|
| R/W-0 | R/W-0 | R/W-0 | R/W-0 | R/W-0 | R/W-0 | R/W-0 | R/W-0 |
| NSTDIS | OVAERR | OVBERR | COVAERR | COVBERR | OVATE | OVBTE | COVTE |
| bit 15 | | | | | | | bit 8 |

| | | | | | | | |
|----------|---------|---------|---------|---------|--------|---------|-------|
| R/W-0 | R/W-0 | R/W-0 | R/W-0 | R/W-0 | R/W-0 | R/W-0 | U-0 |
| SFTACERR | DIV0ERR | DMACERR | MATHERR | ADDRERR | STKERR | OSCFAIL | — |
| bit 7 | | | | | | | bit 0 |

Legend:

R = Readable bit W = Writable bit U = Unimplemented bit, read as '0'
-n = Value at POR '1' = Bit is set '0' = Bit is cleared x = Bit is unknown

- bit 15 **NSTDIS:** Interrupt Nesting Disable bit
1 = Interrupt nesting is disabled
0 = Interrupt nesting is enabled
- bit 14 **OVAERR:** Accumulator A Overflow Trap Flag bit
1 = Trap was caused by overflow of Accumulator A
0 = Trap was not caused by overflow of Accumulator A
- bit 13 **OVBERR:** Accumulator B Overflow Trap Flag bit
1 = Trap was caused by overflow of Accumulator B
0 = Trap was not caused by overflow of Accumulator B
- bit 12 **COVAERR:** Accumulator A Catastrophic Overflow Trap Flag bit
1 = Trap was caused by catastrophic overflow of Accumulator A
0 = Trap was not caused by catastrophic overflow of Accumulator A
- bit 11 **COVBERR:** Accumulator B Catastrophic Overflow Trap Flag bit
1 = Trap was caused by catastrophic overflow of Accumulator B
0 = Trap was not caused by catastrophic overflow of Accumulator B
- bit 10 **OVATE:** Accumulator A Overflow Trap Enable bit
1 = Trap overflow of Accumulator A
0 = Trap is disabled
- bit 9 **OVBTE:** Accumulator B Overflow Trap Enable bit
1 = Trap overflow of Accumulator B
0 = Trap is disabled
- bit 8 **COVTE:** Catastrophic Overflow Trap Enable bit
1 = Trap on catastrophic overflow of Accumulator A or B is enabled
0 = Trap is disabled
- bit 7 **SFTACERR:** Shift Accumulator Error Status bit
1 = Math error trap was caused by an invalid accumulator shift
0 = Math error trap was not caused by an invalid accumulator shift
- bit 6 **DIV0ERR:** Arithmetic Error Status bit
1 = Math error trap was caused by a divide-by-zero
0 = Math error trap was not caused by a divide-by-zero
- bit 5 **DMACERR:** DMA Controller Error Status bit
1 = DMA Controller error trap has occurred
0 = DMA Controller error trap has not occurred
- bit 4 **MATHERR:** Arithmetic Error Status bit
1 = Math error trap has occurred
0 = Math error trap has not occurred

REGISTER 7-3: INTCON1: INTERRUPT CONTROL REGISTER 1 (CONTINUED)

- bit 3 **ADDRERR:** Address Error Trap Status bit
 1 = Address error trap has occurred
 0 = Address error trap has not occurred
- bit 2 **STKERR:** Stack Error Trap Status bit
 1 = Stack error trap has occurred
 0 = Stack error trap has not occurred
- bit 1 **OSCFAIL:** Oscillator Failure Trap Status bit
 1 = Oscillator failure trap has occurred
 0 = Oscillator failure trap has not occurred
- bit 0 **Unimplemented:** Read as '0'

dsPIC33FJ32GS406/606/608/610 and dsPIC33FJ64GS406/606/608/610

REGISTER 7-4: INTCON2: INTERRUPT CONTROL REGISTER 2

| | | | | | | | |
|--------|------|-----|-----|-----|-----|-----|-------|
| R/W-0 | R-0 | U-0 | U-0 | U-0 | U-0 | U-0 | U-0 |
| ALTIVT | DISI | — | — | — | — | — | — |
| bit 15 | | | | | | | bit 8 |

| | | | | | | | |
|-------|-----|-----|--------|--------|--------|--------|--------|
| U-0 | U-0 | U-0 | R/W-0 | R/W-0 | R/W-0 | R/W-0 | R/W-0 |
| — | — | — | INT4EP | INT3EP | INT2EP | INT1EP | INT0EP |
| bit 7 | | | | | | | bit 0 |

Legend:

R = Readable bit W = Writable bit U = Unimplemented bit, read as '0'
 -n = Value at POR '1' = Bit is set '0' = Bit is cleared x = Bit is unknown

- bit 15 **ALTIVT:** Enable Alternate Interrupt Vector Table bit
 1 = Uses Alternate Interrupt Vector Table
 0 = Uses standard (default) Interrupt Vector Table
- bit 14 **DISI:** DISI Instruction Status bit
 1 = DISI instruction is active
 0 = DISI instruction is not active
- bit 13-5 **Unimplemented:** Read as '0'
- bit 4 **INT4EP:** External Interrupt 4 Edge Detect Polarity Select bit
 1 = Interrupt on negative edge
 0 = Interrupt on positive edge
- bit 3 **INT3EP:** External Interrupt 3 Edge Detect Polarity Select bit
 1 = Interrupt on negative edge
 0 = Interrupt on positive edge
- bit 2 **INT2EP:** External Interrupt 2 Edge Detect Polarity Select bit
 1 = Interrupt on negative edge
 0 = Interrupt on positive edge
- bit 1 **INT1EP:** External Interrupt 1 Edge Detect Polarity Select bit
 1 = Interrupt on negative edge
 0 = Interrupt on positive edge
- bit 0 **INT0EP:** External Interrupt 0 Edge Detect Polarity Select bit
 1 = Interrupt on negative edge
 0 = Interrupt on positive edge

dsPIC33FJ32GS406/606/608/610 and dsPIC33FJ64GS406/606/608/610

REGISTER 7-5: IFS0: INTERRUPT FLAG STATUS REGISTER 0

| | | | | | | | |
|--------|--------|-------|--------|--------|--------|---------|-------|
| U-0 | R/W-0 | R/W-0 | R/W-0 | R/W-0 | R/W-0 | R/W-0 | R/W-0 |
| — | DMA1IF | ADIF | U1TXIF | U1RXIF | SPI1IF | SPI1EIF | T3IF |
| bit 15 | | | | | | | bit 8 |

| | | | | | | | |
|-------|-------|-------|--------|-------|-------|-------|--------|
| R/W-0 | R/W-0 | R/W-0 | R/W-0 | R/W-0 | R/W-0 | R/W-0 | R/W-0 |
| T2IF | OC2IF | IC2IF | DMA0IF | T1IF | OC1IF | IC1IF | INT0IF |
| bit 7 | | | | | | | bit 0 |

Legend:

R = Readable bit

W = Writable bit

U = Unimplemented bit, read as '0'

-n = Value at POR

'1' = Bit is set

'0' = Bit is cleared

x = Bit is unknown

- bit 15 **Unimplemented:** Read as '0'
- bit 14 **DMA1IF:** DMA Channel 1 Data Transfer Complete Interrupt Flag Status bit
1 = Interrupt request has occurred
0 = Interrupt request has not occurred
- bit 13 **ADIF:** ADC Group Conversion Complete Interrupt Flag Status bit
1 = Interrupt request has occurred
0 = Interrupt request has not occurred
- bit 12 **U1TXIF:** UART1 Transmitter Interrupt Flag Status bit
1 = Interrupt request has occurred
0 = Interrupt request has not occurred
- bit 11 **U1RXIF:** UART1 Receiver Interrupt Flag Status bit
1 = Interrupt request has occurred
0 = Interrupt request has not occurred
- bit 10 **SPI1IF:** SPI1 Event Interrupt Flag Status bit
1 = Interrupt request has occurred
0 = Interrupt request has not occurred
- bit 9 **SPI1EIF:** SPI1 Fault Interrupt Flag Status bit
1 = Interrupt request has occurred
0 = Interrupt request has not occurred
- bit 8 **T3IF:** Timer3 Interrupt Flag Status bit
1 = Interrupt request has occurred
0 = Interrupt request has not occurred
- bit 7 **T2IF:** Timer2 Interrupt Flag Status bit
1 = Interrupt request has occurred
0 = Interrupt request has not occurred
- bit 6 **OC2IF:** Output Compare Channel 2 Interrupt Flag Status bit
1 = Interrupt request has occurred
0 = Interrupt request has not occurred
- bit 5 **IC2IF:** Input Capture Channel 2 Interrupt Flag Status bit
1 = Interrupt request has occurred
0 = Interrupt request has not occurred
- bit 4 **DMA0IF:** DMA Channel 0 Data Transfer Complete Interrupt Flag Status bit
1 = Interrupt request has occurred
0 = Interrupt request has not occurred
- bit 3 **T1IF:** Timer1 Interrupt Flag Status bit
1 = Interrupt request has occurred
0 = Interrupt request has not occurred

REGISTER 7-5: IFS0: INTERRUPT FLAG STATUS REGISTER 0 (CONTINUED)

- bit 2 **OC1IF:** Output Compare Channel 1 Interrupt Flag Status bit
 1 = Interrupt request has occurred
 0 = Interrupt request has not occurred
- bit 1 **IC1IF:** Input Capture Channel 1 Interrupt Flag Status bit
 1 = Interrupt request has occurred
 0 = Interrupt request has not occurred
- bit 0 **INT0IF:** External Interrupt 0 Flag Status bit
 1 = Interrupt request has occurred
 0 = Interrupt request has not occurred

dsPIC33FJ32GS406/606/608/610 and dsPIC33FJ64GS406/606/608/610

REGISTER 7-6: IFS1: INTERRUPT FLAG STATUS REGISTER 1

| | | | | | | | |
|--------|--------|--------|-------|-------|-------|-------|--------|
| R/W-0 | R/W-0 | R/W-0 | R/W-0 | R/W-0 | R/W-0 | R/W-0 | R/W-0 |
| U2TXIF | U2RXIF | INT2IF | T5IF | T4IF | OC4IF | OC3IF | DMA2IF |
| bit 15 | | | | | | | bit 8 |

| | | | | | | | |
|-------|-----|-----|--------|-------|-------|---------|---------|
| U-0 | U-0 | U-0 | R/W-0 | R/W-0 | R/W-0 | R/W-0 | R/W-0 |
| — | — | — | INT1IF | CNIF | AC1IF | MI2C1IF | SI2C1IF |
| bit 7 | | | | | | | bit 0 |

Legend:

R = Readable bit W = Writable bit U = Unimplemented bit, read as '0'
 -n = Value at POR '1' = Bit is set '0' = Bit is cleared x = Bit is unknown

- bit 12 **U2TXIF:** UART2 Transmitter Interrupt Flag Status bit
 1 = Interrupt request has occurred
 0 = Interrupt request has not occurred
- bit 11 **U2RXIF:** UART2 Receiver Interrupt Flag Status bit
 1 = Interrupt request has occurred
 0 = Interrupt request has not occurred
- bit 13 **INT2IF:** External Interrupt 2 Flag Status bit
 1 = Interrupt request has occurred
 0 = Interrupt request has not occurred
- bit 12 **T5IF:** Timer5 Interrupt Flag Status bit
 1 = Interrupt request has occurred
 0 = Interrupt request has not occurred
- bit 11 **T4IF:** Timer4 Interrupt Flag Status bit
 1 = Interrupt request has occurred
 0 = Interrupt request has not occurred
- bit 10 **OC4IF:** Output Compare Channel 4 Interrupt Flag Status bit
 1 = Interrupt request has occurred
 0 = Interrupt request has not occurred
- bit 9 **OC3IF:** Output Compare Channel 3 Interrupt Flag Status bit
 1 = Interrupt request has occurred
 0 = Interrupt request has not occurred
- bit 8 **DMA2IF:** DMA Channel 2 Data Transfer Complete Interrupt Flag Status bit
 1 = Interrupt request has occurred
 0 = Interrupt request has not occurred
- bit 7-5 **Unimplemented:** Read as '0'
- bit 4 **INT1IF:** External Interrupt 1 Flag Status bit
 1 = Interrupt request has occurred
 0 = Interrupt request has not occurred
- bit 3 **CNIF:** Input Change Notification Interrupt Flag Status bit
 1 = Interrupt request has occurred
 0 = Interrupt request has not occurred
- bit 2 **AC1IF:** Analog Comparator 1 Interrupt Flag Status bit
 1 = Interrupt request has occurred
 0 = Interrupt request has not occurred
- bit 1 **MI2C1IF:** I2C1 Master Events Interrupt Flag Status bit
 1 = Interrupt request has occurred
 0 = Interrupt request has not occurred
- bit 0 **SI2C1IF:** I2C1 Slave Events Interrupt Flag Status bit
 1 = Interrupt request has occurred
 0 = Interrupt request has not occurred

dsPIC33FJ32GS406/606/608/610 and dsPIC33FJ64GS406/606/608/610

REGISTER 7-7: IFS2: INTERRUPT FLAG STATUS REGISTER 2

| | | | | | | | |
|--------|-----|-----|-----|-----|-----|-------|-----|
| U-0 | U-0 | U-0 | U-0 | U-0 | U-0 | U-0 | U-0 |
| — | — | — | — | — | — | — | — |
| bit 15 | | | | | | bit 8 | |

| | | | | | | | |
|-------|-------|-------|--------|---------------------|-----------------------|--------|---------|
| U-0 | R/W-0 | R/W-0 | R/W-0 | R/W-0 | R/W-0 | R/W-0 | R/W-0 |
| — | IC4IF | IC3IF | DMA3IF | C1IF ⁽¹⁾ | C1RXIF ⁽¹⁾ | SPI2IF | SPI2EIF |
| bit 7 | | | | | | bit 0 | |

Legend:

R = Readable bit W = Writable bit U = Unimplemented bit, read as '0'
-n = Value at POR '1' = Bit is set '0' = Bit is cleared x = Bit is unknown

- bit 15-7 **Unimplemented:** Read as '0'
- bit 6 **IC4IF:** Input Capture Channel 4 Interrupt Flag Status bit
1 = Interrupt request has occurred
0 = Interrupt request has not occurred
- bit 5 **IC3IF:** Input Capture Channel 3 Interrupt Flag Status bit
1 = Interrupt request has occurred
0 = Interrupt request has not occurred
- bit 4 **DMA3IF:** DMA Channel 3 Data Transfer Complete Interrupt Flag Status bit
1 = Interrupt request has occurred
0 = Interrupt request has not occurred
- bit 3 **C1IF:** ECAN1 Event Interrupt Flag Status bit⁽¹⁾
1 = Interrupt request has occurred
0 = Interrupt request has not occurred
- bit 2 **C1RXIF:** ECAN1 External Event Interrupt Flag Status bit⁽¹⁾
1 = Interrupt request has occurred
0 = Interrupt request has not occurred
- bit 1 **SPI2IF:** SPI2 Event Interrupt Flag Status bit
1 = Interrupt request has occurred
0 = Interrupt request has not occurred
- bit 0 **SPI2EIF:** SPI2 Error Interrupt Flag Status bit
1 = Interrupt request has occurred
0 = Interrupt request has not occurred

Note 1: Interrupts are disabled on devices without ECAN™ modules.

dsPIC33FJ32GS406/606/608/610 and dsPIC33FJ64GS406/606/608/610

REGISTER 7-8: IFS3: INTERRUPT FLAG STATUS REGISTER 3

| | | | | | | | |
|--------|-----|-----|-----|-----|--------|--------|-----|
| U-0 | U-0 | U-0 | U-0 | U-0 | R/W-0 | R/W-0 | U-0 |
| — | — | — | — | — | QE11IF | PSEMIF | — |
| bit 15 | | | | | | bit 8 | |

| | | | | | | | |
|-------|--------|--------|-----|-----|---------|---------|-----|
| U-0 | R/W-0 | R/W-0 | U-0 | U-0 | R/W-0 | R/W-0 | U-0 |
| — | INT4IF | INT3IF | — | — | MI2C2IF | SI2C2IF | — |
| bit 7 | | | | | | bit 0 | |

Legend:

R = Readable bit W = Writable bit U = Unimplemented bit, read as '0'
 -n = Value at POR '1' = Bit is set '0' = Bit is cleared x = Bit is unknown

- bit 15-11 **Unimplemented:** Read as '0'
- bit 10 **QE11IF:** QE11 Event Interrupt Flag Status bit
 1 = Interrupt request has occurred
 0 = Interrupt request has not occurred
- bit 9 **PSEMIF:** PWM Special Event Match Interrupt Flag Status bit
 1 = Interrupt request has occurred
 0 = Interrupt request has not occurred
- bit 8-7 **Unimplemented:** Read as '0'
- bit 6 **INT4IF:** External Interrupt 4 Flag Status bit
 1 = Interrupt request has occurred
 0 = Interrupt request has not occurred
- bit 5 **INT3IF:** External Interrupt 3 Flag Status bit
 1 = Interrupt request has occurred
 0 = Interrupt request has not occurred
- bit 4-3 **Unimplemented:** Read as '0'
- bit 2 **MI2C2IF:** I2C2 Master Events Interrupt Flag Status bit
 1 = Interrupt request has occurred
 0 = Interrupt request has not occurred
- bit 1 **SI2C2IF:** I2C2 Slave Events Interrupt Flag Status bit
 1 = Interrupt request has occurred
 0 = Interrupt request has not occurred
- bit 0 **Unimplemented:** Read as '0'

dsPIC33FJ32GS406/606/608/610 and dsPIC33FJ64GS406/606/608/610

REGISTER 7-9: IFS4: INTERRUPT FLAG STATUS REGISTER 4

| | | | | | | | |
|--------|-----|-----|-----|--------|-----|---------|-----|
| U-0 | U-0 | U-0 | U-0 | R/W-0 | U-0 | R/W-0 | U-0 |
| — | — | — | — | QEI2IF | — | PSESMIF | — |
| bit 15 | | | | bit 8 | | | |

| | | | | | | | |
|-------|-----------------------|-----|-----|-------|-------|-------|-----|
| U-0 | R/W-0 | U-0 | U-0 | U-0 | R/W-0 | R/W-0 | U-0 |
| — | C1TXIF ⁽¹⁾ | — | — | — | U2EIF | U1EIF | — |
| bit 7 | | | | bit 0 | | | |

Legend:

R = Readable bit W = Writable bit U = Unimplemented bit, read as '0'
 -n = Value at POR '1' = Bit is set '0' = Bit is cleared x = Bit is unknown

- bit 15-12 **Unimplemented:** Read as '0'
- bit 11 **QEI2IF:** QEI2 Event Interrupt Flag Status bit
 1 = Interrupt request has occurred
 0 = Interrupt request has not occurred
- bit 10 **Unimplemented:** Read as '0'
- bit 9 **PSESMIF:** PWM Special Event Secondary Match Interrupt Flag Status bit
 1 = Interrupt request has occurred
 0 = Interrupt request has not occurred
- bit 8-7 **Unimplemented:** Read as '0'
- bit 6 **C1TXIF:** ECAN1 Transmit Data Request Interrupt Flag Status bit⁽¹⁾
 1 = Interrupt request has occurred
 0 = Interrupt request has not occurred
- bit 5-3 **Unimplemented:** Read as '0'
- bit 2 **U2EIF:** UART2 Error Interrupt Flag Status bit
 1 = Interrupt request has occurred
 0 = Interrupt request has not occurred
- bit 1 **U1EIF:** UART1 Error Interrupt Flag Status bit
 1 = Interrupt request has occurred
 0 = Interrupt request has not occurred
- bit 0 **Unimplemented:** Read as '0'

Note 1: Interrupts are disabled on devices without ECAN™ modules.

dsPIC33FJ32GS406/606/608/610 and dsPIC33FJ64GS406/606/608/610

REGISTER 7-10: IFS5: INTERRUPT FLAG STATUS REGISTER 5

| | | | | | | | |
|--------|--------|----------|-----|-----|-----|-----|-------|
| R/W-0 | R/W-0 | R/W-0 | U-0 | U-0 | U-0 | U-0 | U-0 |
| PWM2IF | PWM1IF | ADCP12IF | — | — | — | — | — |
| bit 15 | | | | | | | bit 8 |

| | | | | | | | |
|-------|-----|-----|----------|----------|---------|---------|-------|
| U-0 | U-0 | U-0 | R/W-0 | R/W-0 | R/W-0 | R/W-0 | U-0 |
| — | — | — | ADCP11IF | ADCP10IF | ADCP9IF | ADCP8IF | — |
| bit 7 | | | | | | | bit 0 |

Legend:

R = Readable bit W = Writable bit U = Unimplemented bit, read as '0'
 -n = Value at POR '1' = Bit is set '0' = Bit is cleared x = Bit is unknown

- bit 15 **PWM2IF:** PWM2 Interrupt Flag Status bit
 1 = Interrupt request has occurred
 0 = Interrupt request has not occurred
- bit 14 **PWM1IF:** PWM1 Interrupt Flag Status bit
 1 = Interrupt request has occurred
 0 = Interrupt request has not occurred
- bit 13 **ADCP12IF:** ADC Pair 12 Conversion Done Interrupt Flag Status bit
 1 = Interrupt request has occurred
 0 = Interrupt request has not occurred
- bit 12-5 **Unimplemented:** Read as '0'
- bit 4 **ADCP11IF:** ADC Pair 11 Conversion Done Interrupt Flag Status bit
 1 = Interrupt request has occurred
 0 = Interrupt request has not occurred
- bit 3 **ADCP10IF:** ADC Pair 10 Conversion Done Interrupt Flag Status bit
 1 = Interrupt request has occurred
 0 = Interrupt request has not occurred
- bit 2 **ADCP9IF:** ADC Pair 9 Conversion Done Interrupt Flag Status bit
 1 = Interrupt request has occurred
 0 = Interrupt request has not occurred
- bit 1 **ADCP8IF:** ADC Pair 8 Conversion Done Interrupt Flag Status bit
 1 = Interrupt request has occurred
 0 = Interrupt request has not occurred
- bit 0 **Unimplemented:** Read as '0'

dsPIC33FJ32GS406/606/608/610 and dsPIC33FJ64GS406/606/608/610

REGISTER 7-11: IFS6: INTERRUPT FLAG STATUS REGISTER 6

| | | | | | | | |
|---------|---------|-----|-----|-----|-----|-------|-------|
| R/W-0 | R/W-0 | U-0 | U-0 | U-0 | U-0 | R/W-0 | R/W-0 |
| ADCP1IF | ADCP0IF | — | — | — | — | AC4IF | AC3IF |
| bit 15 | | | | | | bit 8 | |

| | | | | | | | |
|-------|--------|--------|--------|--------|--------|--------|--------|
| R/W-0 | R/W-0 | R/W-0 | R/W-0 | R/W-0 | R/W-0 | R/W-0 | R/W-0 |
| AC2IF | PWM9IF | PWM8IF | PWM7IF | PWM6IF | PWM5IF | PWM4IF | PWM3IF |
| bit 7 | | | | | | bit 0 | |

Legend:

R = Readable bit W = Writable bit U = Unimplemented bit, read as '0'
-n = Value at POR '1' = Bit is set '0' = Bit is cleared x = Bit is unknown

- bit 15 **ADCP1IF:** ADC Pair 1 Conversion Done Interrupt Flag Status bit
 1 = Interrupt request has occurred
 0 = Interrupt request has not occurred
- bit 14 **ADCP0IF:** ADC Pair 0 Conversion Done Interrupt Flag Status bit
 1 = Interrupt request has occurred
 0 = Interrupt request has not occurred
- bit 13-10 **Unimplemented:** Read as '0'
- bit 9 **AC4IF:** Analog Comparator 4 Interrupt Flag Status bit
 1 = Interrupt request has occurred
 0 = Interrupt request has not occurred
- bit 8 **AC3IF:** Analog Comparator 3 Interrupt Flag Status bit
 1 = Interrupt request has occurred
 0 = Interrupt request has not occurred
- bit 7 **AC2IF:** Analog Comparator 2 Interrupt Flag Status bit
 1 = Interrupt request has occurred
 0 = Interrupt request has not occurred
- bit 6 **PWM9IF:** PWM9 Interrupt Flag Status bit
 1 = Interrupt request has occurred
 0 = Interrupt request has not occurred
- bit 5 **PWM8IF:** PWM8 Interrupt Flag Status bit
 1 = Interrupt request has occurred
 0 = Interrupt request has not occurred
- bit 4 **PWM7IF:** PWM7 Interrupt Flag Status bit
 1 = Interrupt request has occurred
 0 = Interrupt request has not occurred
- bit 3 **PWM6IF:** PWM6 Interrupt Flag Status bit
 1 = Interrupt request has occurred
 0 = Interrupt request has not occurred
- bit 2 **PWM5IF:** PWM5 Interrupt Flag Status bit
 1 = Interrupt request has occurred
 0 = Interrupt request has not occurred
- bit 1 **PWM4IF:** PWM4 Interrupt Flag Status bit
 1 = Interrupt request has occurred
 0 = Interrupt request has not occurred
- bit 0 **PWM3IF:** PWM3 Interrupt Flag Status bit
 1 = Interrupt request has occurred
 0 = Interrupt request has not occurred

dsPIC33FJ32GS406/606/608/610 and dsPIC33FJ64GS406/606/608/610

REGISTER 7-12: IFS7: INTERRUPT FLAG STATUS REGISTER 7

| | | | | | | | |
|--------|-----|-----|-----|-----|-----|-------|-----|
| U-0 | U-0 | U-0 | U-0 | U-0 | U-0 | U-0 | U-0 |
| — | — | — | — | — | — | — | — |
| bit 15 | | | | | | bit 8 | |

| | | | | | | | |
|-------|-----|---------|---------|---------|---------|---------|---------|
| U-0 | U-0 | R/W-0 | R/W-0 | R/W-0 | R/W-0 | R/W-0 | R/W-0 |
| — | — | ADCP7IF | ADCP6IF | ADCP5IF | ADCP4IF | ADCP3IF | ADCP2IF |
| bit 7 | | | | | | bit 0 | |

Legend:

R = Readable bit

W = Writable bit

U = Unimplemented bit, read as '0'

-n = Value at POR

'1' = Bit is set

'0' = Bit is cleared

x = Bit is unknown

- bit 15-6 **Unimplemented:** Read as '0'
- bit 5 **ADCP7IF:** ADC Pair 7 Conversion Done Interrupt Flag Status bit
1 = Interrupt request has occurred
0 = Interrupt request has not occurred
- bit 4 **ADCP6IF:** ADC Pair 6 Conversion Done Interrupt Flag Status bit
1 = Interrupt request has occurred
0 = Interrupt request has not occurred
- bit 3 **ADCP5IF:** ADC Pair 5 Conversion Done Interrupt Flag Status bit
1 = Interrupt request has occurred
0 = Interrupt request has not occurred
- bit 2 **ADCP4IF:** ADC Pair 4 Conversion Done Interrupt Flag Status bit
1 = Interrupt request has occurred
0 = Interrupt request has not occurred
- bit 1 **ADCP3IF:** ADC Pair 3 Conversion Done Interrupt Flag Status bit
1 = Interrupt request has occurred
0 = Interrupt request has not occurred
- bit 0 **ADCP2IF:** ADC Pair 2 Conversion Done Interrupt Flag Status bit
1 = Interrupt request has occurred
0 = Interrupt request has not occurred

dsPIC33FJ32GS406/606/608/610 and dsPIC33FJ64GS406/606/608/610

REGISTER 7-13: IEC0: INTERRUPT ENABLE CONTROL REGISTER 0

| | | | | | | | |
|--------|--------|-------|--------|--------|--------|---------|-------|
| U-0 | R/W-0 | R/W-0 | R/W-0 | R/W-0 | R/W-0 | R/W-0 | R/W-0 |
| — | DMA1IE | ADIE | U1TXIE | U1RXIE | SPI1IE | SPI1EIE | T3IE |
| bit 15 | | | | | | | bit 8 |

| | | | | | | | |
|-------|-------|-------|--------|-------|-------|-------|--------|
| R/W-0 | R/W-0 | R/W-0 | R/W-0 | R/W-0 | R/W-0 | R/W-0 | R/W-0 |
| T2IE | OC2IE | IC2IE | DMA0IE | T1IE | OC1IE | IC1IE | INT0IE |
| bit 7 | | | | | | | bit 0 |

Legend:

R = Readable bit W = Writable bit U = Unimplemented bit, read as '0'
 -n = Value at POR '1' = Bit is set '0' = Bit is cleared x = Bit is unknown

- bit 15 **Unimplemented:** Read as '0'
- bit 14 **DMA1IE:** DMA Channel 1 Data Transfer Complete Interrupt Enable bit
 1 = Interrupt request enabled
 0 = Interrupt request not enabled
- bit 13 **ADIE:** ADC1 Conversion Complete Interrupt Enable bit
 1 = Interrupt request enabled
 0 = Interrupt request not enabled
- bit 12 **U1TXIE:** UART1 Transmitter Interrupt Enable bit
 1 = Interrupt request enabled
 0 = Interrupt request not enabled
- bit 11 **U1RXIE:** UART1 Receiver Interrupt Enable bit
 1 = Interrupt request enabled
 0 = Interrupt request not enabled
- bit 10 **SPI1IE:** SPI1 Event Interrupt Enable bit
 1 = Interrupt request enabled
 0 = Interrupt request not enabled
- bit 9 **SPI1EIE:** SPI1 Event Interrupt Enable bit
 1 = Interrupt request enabled
 0 = Interrupt request not enabled
- bit 8 **T3IE:** Timer3 Interrupt Enable bit
 1 = Interrupt request enabled
 0 = Interrupt request not enabled
- bit 7 **T2IE:** Timer2 Interrupt Enable bit
 1 = Interrupt request enabled
 0 = Interrupt request not enabled
- bit 6 **OC2IE:** Output Compare Channel 2 Interrupt Enable bit
 1 = Interrupt request enabled
 0 = Interrupt request not enabled
- bit 5 **IC2IE:** Input Capture Channel 2 Interrupt Enable bit
 1 = Interrupt request enabled
 0 = Interrupt request not enabled
- bit 4 **DMA0IE:** DMA Channel 0 Data Transfer Complete Interrupt Enable bit
 1 = Interrupt request enabled
 0 = Interrupt request not enabled
- bit 3 **T1IE:** Timer1 Interrupt Enable bit
 1 = Interrupt request enabled
 0 = Interrupt request not enabled

REGISTER 7-13: IEC0: INTERRUPT ENABLE CONTROL REGISTER 0 (CONTINUED)

- bit 2 **OC1IE:** Output Compare Channel 1 Interrupt Enable bit
 1 = Interrupt request enabled
 0 = Interrupt request not enabled
- bit 1 **IC1IE:** Input Capture Channel 1 Interrupt Enable bit
 1 = Interrupt request enabled
 0 = Interrupt request not enabled
- bit 0 **INT0IE:** External Interrupt 0 Enable bit
 1 = Interrupt request enabled
 0 = Interrupt request not enabled

dsPIC33FJ32GS406/606/608/610 and dsPIC33FJ64GS406/606/608/610

REGISTER 7-14: IEC1: INTERRUPT ENABLE CONTROL REGISTER 1

| | | | | | | | |
|--------|--------|--------|-------|-------|-------|-------|--------|
| R/W-0 | R/W-0 | R/W-0 | R/W-0 | R/W-0 | R/W-0 | R/W-0 | R/W-0 |
| U2TXIE | U2RXIE | INT2IE | T5IE | T4IE | OC4IE | OC3IE | DMA2IE |
| bit 15 | | | | | | | bit 8 |

| | | | | | | | |
|-------|-----|-----|--------|-------|-------|---------|---------|
| U-0 | U-0 | U-0 | R/W-0 | R/W-0 | R/W-0 | R/W-0 | R/W-0 |
| — | — | — | INT1IE | CNIE | AC1IE | MI2C1IE | SI2C1IE |
| bit 7 | | | | | | | bit 0 |

Legend:

R = Readable bit W = Writable bit U = Unimplemented bit, read as '0'
-n = Value at POR '1' = Bit is set '0' = Bit is cleared x = Bit is unknown

- bit 12 **U2TXIE:** UART2 Transmitter Interrupt Enable bit
1 = Interrupt request enabled
0 = Interrupt request not enabled
- bit 11 **U2RXIE:** UART2 Receiver Interrupt Enable bit
1 = Interrupt request enabled
0 = Interrupt request not enabled
- bit 13 **INT2IE:** External Interrupt 2 Enable bit
1 = Interrupt request enabled
0 = Interrupt request not enabled
- bit 12 **T5IE:** Timer5 Interrupt Enable bit
1 = Interrupt request enabled
0 = Interrupt request not enabled
- bit 11 **T4IE:** Timer4 Interrupt Enable bit
1 = Interrupt request enabled
0 = Interrupt request not enabled
- bit 10 **OC4IE:** Output Compare Channel 4 Interrupt Enable bit
1 = Interrupt request enabled
0 = Interrupt request not enabled
- bit 9 **OC3IE:** Output Compare Channel 3 Interrupt Enable bit
1 = Interrupt request enabled
0 = Interrupt request not enabled
- bit 8 **DMA2IE:** DMA Channel 2 Data Transfer Complete Interrupt Enable bit
1 = Interrupt request enabled
0 = Interrupt request not enabled
- bit 7-5 **Unimplemented:** Read as '0'
- bit 4 **INT1IE:** External Interrupt 1 Enable bit
1 = Interrupt request enabled
0 = Interrupt request not enabled
- bit 3 **CNIE:** Input Change Notification Interrupt Enable bit
1 = Interrupt request enabled
0 = Interrupt request not enabled
- bit 2 **AC1IE:** Analog Comparator 1 Interrupt Enable bit
1 = Interrupt request enabled
0 = Interrupt request not enabled
- bit 1 **MI2C1IE:** I2C1 Master Events Interrupt Enable bit
1 = Interrupt request enabled
0 = Interrupt request not enabled
- bit 0 **SI2C1IE:** I2C1 Slave Events Interrupt Enable bit
1 = Interrupt request enabled
0 = Interrupt request not enabled

dsPIC33FJ32GS406/606/608/610 and dsPIC33FJ64GS406/606/608/610

REGISTER 7-15: IEC2: INTERRUPT ENABLE CONTROL REGISTER 2

| | | | | | | | |
|--------|-----|-----|-----|-----|-----|-----|-------|
| U-0 | U-0 | U-0 | U-0 | U-0 | U-0 | U-0 | U-0 |
| — | — | — | — | — | — | — | — |
| bit 15 | | | | | | | bit 8 |

| | | | | | | | |
|-------|-------|-------|--------|---------------------|-----------------------|--------|---------|
| U-0 | R/W-0 | R/W-0 | R/W-0 | R/W-0 | R/W-0 | R/W-0 | R/W-0 |
| — | IC4IE | IC3IE | DMA3IE | C1IE ⁽¹⁾ | C1RXIE ⁽¹⁾ | SPI2IE | SPI2EIE |
| bit 7 | | | | | | | bit 0 |

Legend:

R = Readable bit W = Writable bit U = Unimplemented bit, read as '0'
 -n = Value at POR '1' = Bit is set '0' = Bit is cleared x = Bit is unknown

- bit 15-7 **Unimplemented:** Read as '0'
- bit 6 **IC4IE:** Input Capture Channel 4 Interrupt Enable bit
 1 = Interrupt request enabled
 0 = Interrupt request not enabled
- bit 5 **IC3IE:** Input Capture Channel 3 Interrupt Enable bit
 1 = Interrupt request enabled
 0 = Interrupt request not enabled
- bit 4 **DMA3IE:** DMA Channel 3 Data Transfer Complete Interrupt Enable bit
 1 = Interrupt request enabled
 0 = Interrupt request has enabled
- bit 3 **C1IE:** ECAN1 Event Interrupt Enable bit⁽¹⁾
 1 = Interrupt request enabled
 0 = Interrupt request not enabled
- bit 2 **C1RXIE:** ECAN1 Receive Data Ready Interrupt Enable bit⁽¹⁾
 1 = Interrupt request enabled
 0 = Interrupt request not enabled
- bit 1 **SPI2IE:** SPI2 Event Interrupt Enable bit
 1 = Interrupt request enabled
 0 = Interrupt request not enabled
- bit 0 **SPI2EIE:** SPI2 Error Interrupt Enable bit
 1 = Interrupt request enabled
 0 = Interrupt request not enabled

Note 1: Interrupts are disabled on devices without ECAN™ modules.

dsPIC33FJ32GS406/606/608/610 and dsPIC33FJ64GS406/606/608/610

REGISTER 7-16: IEC3: INTERRUPT ENABLE CONTROL REGISTER 3

| | | | | | | | |
|--------|-----|-----|-----|-----|--------|--------|-----|
| U-0 | U-0 | U-0 | U-0 | U-0 | R/W-0 | R/W-0 | U-0 |
| — | — | — | — | — | QE11IE | PSEMIE | — |
| bit 15 | | | | | | bit 8 | |

| | | | | | | | |
|-------|--------|--------|-----|-----|---------|---------|-----|
| U-0 | R/W-0 | R/W-0 | U-0 | U-0 | R/W-0 | R/W-0 | U-0 |
| — | INT4IE | INT3IE | — | — | MI2C2IE | SI2C2IE | — |
| bit 7 | | | | | | bit 0 | |

Legend:

R = Readable bit W = Writable bit U = Unimplemented bit, read as '0'
 -n = Value at POR '1' = Bit is set '0' = Bit is cleared x = Bit is unknown

- bit 15-11 **Unimplemented:** Read as '0'
- bit 10 **QE11IE:** QE11 Event Interrupt Enable bit
 1 = Interrupt request enabled
 0 = Interrupt request not enabled
- bit 9 **PSEMIE:** PWM Special Event Match Interrupt Enable bit
 1 = Interrupt request enabled
 0 = Interrupt request not enabled
- bit 8-7 **Unimplemented:** Read as '0'
- bit 6 **INT4IE:** External Interrupt 4 Enable bit
 1 = Interrupt request enabled
 0 = Interrupt request not enabled
- bit 6 **INT3IE:** External Interrupt 3 Enable bit
 1 = Interrupt request enabled
 0 = Interrupt request not enabled
- bit 4-3 **Unimplemented:** Read as '0'
- bit 2 **MI2C2IE:** I2C2 Master Events Interrupt Enable bit
 1 = Interrupt request enabled
 0 = Interrupt request not enabled
- bit 1 **SI2C2IE:** I2C2 Slave Events Interrupt Enable bit
 1 = Interrupt request enabled
 0 = Interrupt request not enabled
- bit 0 **Unimplemented:** Read as '0'

dsPIC33FJ32GS406/606/608/610 and dsPIC33FJ64GS406/606/608/610

REGISTER 7-17: IEC4: INTERRUPT ENABLE CONTROL REGISTER 4

| | | | | | | | |
|--------|-----|-----|-----|--------|-----|---------|-------|
| U-0 | U-0 | U-0 | U-0 | R/W-0 | U-0 | R/W-0 | U-0 |
| — | — | — | — | QEI2IE | — | PSESMIE | — |
| bit 15 | | | | | | | bit 8 |

| | | | | | | | |
|-------|-----------------------|-----|-----|-----|-------|-------|-------|
| U-0 | R/W-0 | U-0 | U-0 | U-0 | R/W-0 | R/W-0 | U-0 |
| — | C1TXIE ⁽¹⁾ | — | — | — | U2EIE | U1EIE | — |
| bit 7 | | | | | | | bit 0 |

Legend:

R = Readable bit W = Writable bit U = Unimplemented bit, read as '0'
 -n = Value at POR '1' = Bit is set '0' = Bit is cleared x = Bit is unknown

- bit 15-12 **Unimplemented:** Read as '0'
- bit 11 **QEI2IE:** QEI2 Event Interrupt Enable bit
 1 = Interrupt request enabled
 0 = Interrupt request not enabled
- bit 10 **Unimplemented:** Read as '0'
- bit 9 **PSESMIE:** PWM Special Event Secondary Match Error Interrupt Enable bit
 1 = Interrupt request enabled
 0 = Interrupt request not enabled
- bit 8-7 **Unimplemented:** Read as '0'
- bit 6 **C1TXIE:** ECAN1 Transmit Data Request Interrupt Enable bit⁽¹⁾
 1 = Interrupt request occurred
 0 = Interrupt request not occurred
- bit 5-3 **Unimplemented:** Read as '0'
- bit 2 **U2EIE:** UART2 Error Interrupt Enable bit
 1 = Interrupt request enabled
 0 = Interrupt request not enabled
- bit 1 **U1EIE:** UART1 Error Interrupt Enable bit
 1 = Interrupt request enabled
 0 = Interrupt request not enabled
- bit 0 **Unimplemented:** Read as '0'

Note 1: Interrupts are disabled on devices without ECAN™ modules.

dsPIC33FJ32GS406/606/608/610 and dsPIC33FJ64GS406/606/608/610

REGISTER 7-18: IEC5: INTERRUPT ENABLE CONTROL REGISTER 5

| | | | | | | | |
|--------|--------|----------|-----|-----|-----|-----|-------|
| R/W-0 | R/W-0 | R/W-0 | U-0 | U-0 | U-0 | U-0 | U-0 |
| PWM2IE | PWM1IE | ADCP12IE | — | — | — | — | — |
| bit 15 | | | | | | | bit 8 |

| | | | | | | | |
|-------|-----|-----|-------|-------|-------|-------|-------|
| U-0 | U-0 | U-0 | R/W-0 | R/W-0 | R/W-0 | R/W-0 | U-0 |
| — | — | — | — | — | — | — | — |
| bit 7 | | | | | | | bit 0 |

Legend:

R = Readable bit W = Writable bit U = Unimplemented bit, read as '0'
-n = Value at POR '1' = Bit is set '0' = Bit is cleared x = Bit is unknown

- bit 15 **PWM2IE:** PWM2 Interrupt Enable bit
 1 = Interrupt request is enabled
 0 = Interrupt request is not enabled
- bit 14 **PWM1IE:** PWM1 Interrupt Enable bit
 1 = Interrupt request is enabled
 0 = Interrupt request is not enabled
- bit 13 **ADCP12IE:** ADC Pair 12 Conversion Done Interrupt Enable bit
 1 = Interrupt request is enabled
 0 = Interrupt request is not enabled
- bit 12-0 **Unimplemented:** Read as '0'

dsPIC33FJ32GS406/606/608/610 and dsPIC33FJ64GS406/606/608/610

REGISTER 7-19: IEC6: INTERRUPT ENABLE CONTROL REGISTER 6

| | | | | | | | |
|---------|---------|-----|-----|-----|-----|-------|-------|
| R/W-0 | R/W-0 | U-0 | U-0 | U-0 | U-0 | R/W-0 | R/W-0 |
| ADCP1IE | ADCP0IE | — | — | — | — | AC4IE | AC3IE |
| bit 15 | | | | | | bit 8 | |

| | | | | | | | |
|-------|-------|-------|-------|--------|--------|--------|--------|
| R/W-0 | R/W-0 | R/W-0 | R/W-0 | R/W-0 | R/W-0 | R/W-0 | R/W-0 |
| AC2IE | — | — | — | PWM6IE | PWM5IE | PWM4IE | PWM3IE |
| bit 7 | | | | | | bit 0 | |

Legend:

R = Readable bit W = Writable bit U = Unimplemented bit, read as '0'
 -n = Value at POR '1' = Bit is set '0' = Bit is cleared x = Bit is unknown

- bit 15 **ADCP1IE:** ADC Pair 1 Conversion Done Interrupt Enable bit
 1 = Interrupt request is enabled
 0 = Interrupt request is not enabled
- bit 14 **ADCP0IE:** ADC Pair 0 Conversion Done Interrupt Enable bit
 1 = Interrupt request is enabled
 0 = Interrupt request is not enabled
- bit 13-10 **Unimplemented:** Read as '0'
- bit 9 **AC4IE:** Analog Comparator 4 Interrupt Enable bit
 1 = Interrupt request is enabled
 0 = Interrupt request is not enabled
- bit 8 **AC3IE:** Analog Comparator 3 Interrupt Enable bit
 1 = Interrupt request is enabled
 0 = Interrupt request is not enabled
- bit 7 **AC2IE:** Analog Comparator 2 Interrupt Enable bit
 1 = Interrupt request is enabled
 0 = Interrupt request is not enabled
- bit 6-4 **Unimplemented:** Read as '0'
- bit 3 **PWM6IE:** PWM6 Interrupt Enable bit
 1 = Interrupt request is enabled
 0 = Interrupt request is not enabled
- bit 2 **PWM5IE:** PWM5 Interrupt Enable bit
 1 = Interrupt request is enabled
 0 = Interrupt request is not enabled
- bit 1 **PWM4IE:** PWM4 Interrupt Enable bit
 1 = Interrupt request is enabled
 0 = Interrupt request is not enabled
- bit 0 **PWM3IE:** PWM3 Interrupt Enable bit
 1 = Interrupt request is enabled
 0 = Interrupt request is not enabled

dsPIC33FJ32GS406/606/608/610 and dsPIC33FJ64GS406/606/608/610

REGISTER 7-20: IEC7: INTERRUPT ENABLE CONTROL REGISTER 7

| | | | | | | | |
|--------|-----|-----|-----|-----|-----|-------|-----|
| U-0 | U-0 | U-0 | U-0 | U-0 | U-0 | U-0 | U-0 |
| — | — | — | — | — | — | — | — |
| bit 15 | | | | | | bit 8 | |

| | | | | | | | |
|-------|-----|---------|---------|---------|---------|---------|---------|
| U-0 | U-0 | R/W-0 | R/W-0 | R/W-0 | R/W-0 | R/W-0 | R/W-0 |
| — | — | ADCP7IE | ADCP6IE | ADCP5IE | ADCP4IE | ADCP3IE | ADCP2IE |
| bit 7 | | | | | | bit 0 | |

Legend:

R = Readable bit
-n = Value at POR

W = Writable bit
'1' = Bit is set

U = Unimplemented bit, read as '0'
'0' = Bit is cleared

x = Bit is unknown

- bit 15-6 **Unimplemented:** Read as '0'
- bit 5 **ADCP7IE:** ADC Pair 7 Conversion Done Interrupt Enable bit
1 = Interrupt request is enabled
0 = Interrupt request is not enabled
- bit 4 **ADCP6IE:** ADC Pair 6 Conversion Done Interrupt Enable bit
1 = Interrupt request is enabled
0 = Interrupt request is not enabled
- bit 3 **ADCP5IE:** ADC Pair 5 Conversion Done Interrupt Enable bit
1 = Interrupt request is enabled
0 = Interrupt request is not enabled
- bit 2 **ADCP4IE:** ADC Pair 4 Conversion Done Interrupt Enable bit
1 = Interrupt request is enabled
0 = Interrupt request is not enabled
- bit 1 **ADCP3IE:** ADC Pair 3 Conversion Done Interrupt Enable bit
1 = Interrupt request is enabled
0 = Interrupt request is not enabled
- bit 0 **ADCP2IE:** ADC Pair 2 Conversion Done Interrupt Enable bit
1 = Interrupt request is enabled
0 = Interrupt request is not enabled

dsPIC33FJ32GS406/606/608/610 and dsPIC33FJ64GS406/606/608/610

REGISTER 7-21: IPC0: INTERRUPT PRIORITY CONTROL REGISTER 0

| | | | | | | | |
|--------|-----------|-------|-------|-------|------------|-------|-------|
| U-0 | R/W-1 | R/W-0 | R/W-0 | U-0 | R/W-1 | R/W-0 | R/W-0 |
| — | T1IP<2:0> | | | — | OC1IP<2:0> | | |
| bit 15 | | | | bit 8 | | | |

| | | | | | | | |
|-------|------------|-------|-------|-------|-------------|-------|-------|
| U-0 | R/W-1 | R/W-0 | R/W-0 | U-0 | R/W-1 | R/W-0 | R/W-0 |
| — | IC1IP<2:0> | | | — | INT0IP<2:0> | | |
| bit 7 | | | | bit 0 | | | |

Legend:

| | | |
|-------------------|------------------|------------------------------------|
| R = Readable bit | W = Writable bit | U = Unimplemented bit, read as '0' |
| -n = Value at POR | '1' = Bit is set | '0' = Bit is cleared |
| | | x = Bit is unknown |

- bit 15 **Unimplemented:** Read as '0'
- bit 14-12 **T1IP<2:0>:** Timer1 Interrupt Priority bits
 - 111 = Interrupt is Priority 7 (highest priority interrupt)
 -
 -
 -
 - 001 = Interrupt is Priority 1
 - 000 = Interrupt source is disabled
- bit 11 **Unimplemented:** Read as '0'
- bit 10-8 **OC1IP<2:0>:** Output Compare Channel 1 Interrupt Priority bits
 - 111 = Interrupt is Priority 7 (highest priority interrupt)
 -
 -
 -
 - 001 = Interrupt is Priority 1
 - 000 = Interrupt source is disabled
- bit 7 **Unimplemented:** Read as '0'
- bit 6-4 **IC1IP<2:0>:** Input Capture Channel 1 Interrupt Priority bits
 - 111 = Interrupt is Priority 7 (highest priority interrupt)
 -
 -
 -
 - 001 = Interrupt is Priority 1
 - 000 = Interrupt source is disabled
- bit 3 **Unimplemented:** Read as '0'
- bit 2-0 **INT0IP<2:0>:** External Interrupt 0 Priority bits
 - 111 = Interrupt is Priority 7 (highest priority interrupt)
 -
 -
 -
 - 001 = Interrupt is Priority 1
 - 000 = Interrupt source is disabled

dsPIC33FJ32GS406/606/608/610 and dsPIC33FJ64GS406/606/608/610

REGISTER 7-22: IPC1: INTERRUPT PRIORITY CONTROL REGISTER 1

| | | | | | | | |
|--------|-----------|-------|-------|-------|------------|-------|-------|
| U-0 | R/W-1 | R/W-0 | R/W-0 | U-0 | R/W-1 | R/W-0 | R/W-0 |
| — | T2IP<2:0> | | | — | OC2IP<2:0> | | |
| bit 15 | | | | bit 8 | | | |

| | | | | | | | |
|-------|------------|-------|-------|-------|-------------|-------|-------|
| U-0 | R/W-1 | R/W-0 | R/W-0 | U-0 | R/W-1 | R/W-0 | R/W-0 |
| — | IC2IP<2:0> | | | — | DMA0IP<2:0> | | |
| bit 7 | | | | bit 0 | | | |

Legend:

| | | |
|-------------------|------------------|------------------------------------|
| R = Readable bit | W = Writable bit | U = Unimplemented bit, read as '0' |
| -n = Value at POR | '1' = Bit is set | '0' = Bit is cleared |
| | | x = Bit is unknown |

- bit 15 **Unimplemented:** Read as '0'
- bit 14-12 **T2IP<2:0>:** Timer2 Interrupt Priority bits
 - 111 = Interrupt is Priority 7 (highest priority interrupt)
 -
 -
 -
 - 001 = Interrupt is Priority 1
 - 000 = Interrupt source is disabled
- bit 11 **Unimplemented:** Read as '0'
- bit 10-8 **OC2IP<2:0>:** Output Compare Channel 2 Interrupt Priority bits
 - 111 = Interrupt is Priority 7 (highest priority interrupt)
 -
 -
 -
 - 001 = Interrupt is Priority 1
 - 000 = Interrupt source is disabled
- bit 7 **Unimplemented:** Read as '0'
- bit 6-4 **IC2IP<2:0>:** Input Capture Channel 2 Interrupt Priority bits
 - 111 = Interrupt is Priority 7 (highest priority interrupt)
 -
 -
 -
 - 001 = Interrupt is Priority 1
 - 000 = Interrupt source is disabled
- bit 3-0 **DMA0IP<2:0>:** DMA Channel 0 Data Transfer Complete Interrupt Priority bits
 - 111 = Interrupt is Priority 7 (highest priority interrupt)
 -
 -
 -
 - 001 = Interrupt is Priority 1
 - 000 = Interrupt source is disabled

dsPIC33FJ32GS406/606/608/610 and dsPIC33FJ64GS406/606/608/610

REGISTER 7-23: IPC2: INTERRUPT PRIORITY CONTROL REGISTER 2

| | | | | | | | |
|--------|-------------|-------|-------|-------|-------------|-------|-------|
| U-0 | R/W-1 | R/W-0 | R/W-0 | U-0 | R/W-1 | R/W-0 | R/W-0 |
| — | U1RXIP<2:0> | | | — | SPI1IP<2:0> | | |
| bit 15 | | | | bit 8 | | | |

| | | | | | | | |
|-------|--------------|-------|-------|-------|-----------|-------|-------|
| U-0 | R/W-1 | R/W-0 | R/W-0 | U-0 | R/W-1 | R/W-0 | R/W-0 |
| — | SPI1EIP<2:0> | | | — | T3IP<2:0> | | |
| bit 7 | | | | bit 0 | | | |

Legend:

| | | |
|-------------------|------------------|------------------------------------|
| R = Readable bit | W = Writable bit | U = Unimplemented bit, read as '0' |
| -n = Value at POR | '1' = Bit is set | '0' = Bit is cleared |
| | | x = Bit is unknown |

- bit 15 **Unimplemented:** Read as '0'
- bit 14-12 **U1RXIP<2:0>:** UART1 Receiver Interrupt Priority bits
 - 111 = Interrupt is Priority 7 (highest priority interrupt)
 -
 -
 -
 - 001 = Interrupt is Priority 1
 - 000 = Interrupt source is disabled
- bit 11 **Unimplemented:** Read as '0'
- bit 10-8 **SPI1IP<2:0>:** SPI1 Event Interrupt Priority bits
 - 111 = Interrupt is Priority 7 (highest priority interrupt)
 -
 -
 -
 - 001 = Interrupt is Priority 1
 - 000 = Interrupt source is disabled
- bit 7 **Unimplemented:** Read as '0'
- bit 6-4 **SPI1EIP<2:0>:** SPI1 Error Interrupt Priority bits
 - 111 = Interrupt is Priority 7 (highest priority interrupt)
 -
 -
 -
 - 001 = Interrupt is Priority 1
 - 000 = Interrupt source is disabled
- bit 3 **Unimplemented:** Read as '0'
- bit 2-0 **T3IP<2:0>:** Timer3 Interrupt Priority bits
 - 111 = Interrupt is Priority 7 (highest priority interrupt)
 -
 -
 -
 - 001 = Interrupt is Priority 1
 - 000 = Interrupt source is disabled

dsPIC33FJ32GS406/606/608/610 and dsPIC33FJ64GS406/606/608/610

REGISTER 7-24: IPC3: INTERRUPT PRIORITY CONTROL REGISTER 3

| | | | | | | | |
|--------|-----|-----|-----|-----|-------------|-------|-------|
| U-0 | U-0 | U-0 | U-0 | U-0 | R/W-1 | R/W-0 | R/W-0 |
| — | — | — | — | — | DMA1IP<2:0> | | |
| bit 15 | | | | | bit 8 | | |

| | | | | | | | |
|-------|-----------|-------|-------|-----|-------------|-------|-------|
| U-0 | R/W-1 | R/W-0 | R/W-0 | U-0 | R/W-1 | R/W-0 | R/W-0 |
| — | ADIP<2:0> | | | — | U1TXIP<2:0> | | |
| bit 7 | | | | | bit 0 | | |

Legend:

R = Readable bit W = Writable bit U = Unimplemented bit, read as '0'
 -n = Value at POR '1' = Bit is set '0' = Bit is cleared x = Bit is unknown

bit 15-11 **Unimplemented:** Read as '0'

bit 10-8 **DMA1IP<2:0>:** DMA Channel 1 Data Transfer Complete Interrupt Priority bits

111 = Interrupt is Priority 7 (highest priority interrupt)

-
-
-

001 = Interrupt is Priority 1

000 = Interrupt source is disabled

bit 7 **Unimplemented:** Read as '0'

bit 6-4 **ADIP<2:0>:** ADC1 Conversion Complete Interrupt Priority bits

111 = Interrupt is Priority 7 (highest priority interrupt)

-
-
-

001 = Interrupt is Priority 1

000 = Interrupt source is disabled

bit 3 **Unimplemented:** Read as '0'

bit 2-0 **U1TXIP<2:0>:** UART1 Transmitter Interrupt Priority bits

111 = Interrupt is Priority 7 (highest priority interrupt)

-
-
-

001 = Interrupt is Priority 1

000 = Interrupt source is disabled

dsPIC33FJ32GS406/606/608/610 and dsPIC33FJ64GS406/606/608/610

REGISTER 7-25: IPC4: INTERRUPT PRIORITY CONTROL REGISTER 4

| | | | | | | | |
|--------|-----------|-------|-------|-------|------------|-------|-------|
| U-0 | R/W-1 | R/W-0 | R/W-0 | U-0 | R/W-1 | R/W-0 | R/W-0 |
| — | CNIP<2:0> | | | — | AC1IP<2:0> | | |
| bit 15 | | | | bit 8 | | | |

| | | | | | | | |
|-------|--------------|-------|-------|-------|--------------|-------|-------|
| U-0 | R/W-1 | R/W-0 | R/W-0 | U-0 | R/W-1 | R/W-0 | R/W-0 |
| — | MI2C1IP<2:0> | | | — | SI2C1IP<2:0> | | |
| bit 7 | | | | bit 0 | | | |

Legend:

| | | |
|-------------------|------------------|------------------------------------|
| R = Readable bit | W = Writable bit | U = Unimplemented bit, read as '0' |
| -n = Value at POR | '1' = Bit is set | '0' = Bit is cleared |
| | | x = Bit is unknown |

- bit 15 **Unimplemented:** Read as '0'
- bit 14-12 **CNIP<2:0>:** Change Notification Interrupt Priority bits
 - 111 = Interrupt is Priority 7 (highest priority interrupt)
 -
 -
 -
 - 001 = Interrupt is Priority 1
 - 000 = Interrupt source is disabled
- bit 11 **Unimplemented:** Read as '0'
- bit 10-8 **AC1IP<2:0>:** Analog Comparator 1 Interrupt Priority bits
 - 111 = Interrupt is Priority 7 (highest priority interrupt)
 -
 -
 -
 - 001 = Interrupt is Priority 1
 - 000 = Interrupt source is disabled
- bit 7 **Unimplemented:** Read as '0'
- bit 6-4 **MI2C1IP<2:0>:** I2C1 Master Events Interrupt Priority bits
 - 111 = Interrupt is Priority 7 (highest priority interrupt)
 -
 -
 -
 - 001 = Interrupt is Priority 1
 - 000 = Interrupt source is disabled
- bit 3 **Unimplemented:** Read as '0'
- bit 2-0 **SI2C1IP<2:0>:** I2C1 Slave Events Interrupt Priority bits
 - 111 = Interrupt is Priority 7 (highest priority interrupt)
 -
 -
 -
 - 001 = Interrupt is Priority 1
 - 000 = Interrupt source is disabled

dsPIC33FJ32GS406/606/608/610 and dsPIC33FJ64GS406/606/608/610

REGISTER 7-26: IPC5: INTERRUPT PRIORITY CONTROL REGISTER 5

| | | | | | | | |
|--------|-----|-----|-----|-----|-----|-------|-----|
| U-0 | U-0 | U-0 | U-0 | U-0 | U-0 | U-0 | U-0 |
| — | — | — | — | — | — | — | — |
| bit 15 | | | | | | bit 8 | |

| | | | | | | | |
|-------|-----|-----|-----|-----|-------------|-------|-------|
| U-0 | U-0 | U-0 | U-0 | U-0 | R/W-1 | R/W-0 | R/W-0 |
| — | — | — | — | — | INT1IP<2:0> | | |
| bit 7 | | | | | bit 0 | | |

Legend:

R = Readable bit W = Writable bit U = Unimplemented bit, read as '0'
 -n = Value at POR '1' = Bit is set '0' = Bit is cleared x = Bit is unknown

bit 15-3 **Unimplemented:** Read as '0'

bit 2-0 **INT1IP<2:0>:** External Interrupt 1 Priority bits
 111 = Interrupt is Priority 7 (highest priority interrupt)
 •
 •
 •
 001 = Interrupt is Priority 1
 000 = Interrupt source is disabled

dsPIC33FJ32GS406/606/608/610 and dsPIC33FJ64GS406/606/608/610

REGISTER 7-27: IPC6: INTERRUPT PRIORITY CONTROL REGISTER 6

| | | | | | | | |
|--------|-----------|-------|-------|-------|------------|-------|-------|
| U-0 | R/W-1 | R/W-0 | R/W-0 | U-0 | R/W-1 | R/W-0 | R/W-0 |
| — | T4IP<2:0> | | | — | OC4IP<2:0> | | |
| bit 15 | | | | bit 8 | | | |

| | | | | | | | |
|-------|------------|-------|-------|-------|-------------|-------|-------|
| U-0 | R/W-1 | R/W-0 | R/W-0 | U-0 | R/W-1 | R/W-0 | R/W-0 |
| — | OC3IP<2:0> | | | — | DMA2IP<2:0> | | |
| bit 7 | | | | bit 0 | | | |

Legend:

R = Readable bit

W = Writable bit

U = Unimplemented bit, read as '0'

-n = Value at POR

'1' = Bit is set

'0' = Bit is cleared

x = Bit is unknown

bit 15 **Unimplemented:** Read as '0'

bit 14-12 **T4IP<2:0>:** Timer4 Interrupt Priority bits

111 = Interrupt is Priority 7 (highest priority interrupt)

•

•

•

001 = Interrupt is Priority 1

000 = Interrupt source is disabled

bit 11 **Unimplemented:** Read as '0'

bit 10-8 **OC4IP<2:0>:** Output Compare Channel 4 Interrupt Priority bits

111 = Interrupt is Priority 7 (highest priority interrupt)

•

•

•

001 = Interrupt is Priority 1

000 = Interrupt source is disabled

bit 7 **Unimplemented:** Read as '0'

bit 6-4 **OC3IP<2:0>:** Output Compare Channel 3 Interrupt Priority bits

111 = Interrupt is Priority 7 (highest priority interrupt)

•

•

•

001 = Interrupt is Priority 1

000 = Interrupt source is disabled

bit 3 **Unimplemented:** Read as '0'

bit 2-0 **DMA2IP<2:0>:** DMA Channel 2 Data Transfer Complete Interrupt Priority bits

111 = Interrupt is Priority 7 (highest priority interrupt)

•

•

•

001 = Interrupt is Priority 1

000 = Interrupt source is disabled

REGISTER 7-28: IPC7: INTERRUPT PRIORITY CONTROL REGISTER 7

| | | | | | | | |
|--------|-------------|-------|-------|-------|-------------|-------|-------|
| U-0 | R/W-1 | R/W-0 | R/W-0 | U-0 | R/W-1 | R/W-0 | R/W-0 |
| — | U2TXIP<2:0> | | | — | U2RXIP<2:0> | | |
| bit 15 | | | | bit 8 | | | |

| | | | | | | | |
|-------|-------------|-------|-------|-------|-----------|-------|-------|
| U-0 | R/W-1 | R/W-0 | R/W-0 | U-0 | R/W-1 | R/W-0 | R/W-0 |
| — | INT2IP<2:0> | | | — | T5IP<2:0> | | |
| bit 7 | | | | bit 0 | | | |

| | | | |
|-------------------|------------------|------------------------------------|--------------------|
| Legend: | | | |
| R = Readable bit | W = Writable bit | U = Unimplemented bit, read as '0' | |
| -n = Value at POR | '1' = Bit is set | '0' = Bit is cleared | x = Bit is unknown |

- bit 15 **Unimplemented:** Read as '0'
- bit 14-12 **U2TXIP<2:0>:** UART2 Transmitter Interrupt Priority bits
 - 111 = Interrupt is Priority 7 (highest priority interrupt)
 -
 -
 -
 - 001 = Interrupt is Priority 1
 - 000 = Interrupt source is disabled
- bit 11 **Unimplemented:** Read as '0'
- bit 10-8 **U2RXIP<2:0>:** UART2 Receiver Interrupt Priority bits
 - 111 = Interrupt is Priority 7 (highest priority interrupt)
 -
 -
 -
 - 001 = Interrupt is Priority 1
 - 000 = Interrupt source is disabled
- bit 7 **Unimplemented:** Read as '0'
- bit 6-4 **INT2IP<2:0>:** External Interrupt 2 Priority bits
 - 111 = Interrupt is Priority 7 (highest priority interrupt)
 -
 -
 -
 - 001 = Interrupt is Priority 1
 - 000 = Interrupt source is disabled
- bit 3 **Unimplemented:** Read as '0'
- bit 2-0 **T5IP<2:0>:** Timer5 Interrupt Priority bits
 - 111 = Interrupt is Priority 7 (highest priority interrupt)
 -
 -
 -
 - 001 = Interrupt is Priority 1
 - 000 = Interrupt source is disabled

dsPIC33FJ32GS406/606/608/610 and dsPIC33FJ64GS406/606/608/610

REGISTER 7-29: IPC8: INTERRUPT PRIORITY CONTROL REGISTER 8

| | | | | | | | |
|--------|--------------------------|-------|-------|-------|----------------------------|-------|-------|
| U-0 | R/W-1 | R/W-0 | R/W-0 | U-0 | R/W-1 | R/W-0 | R/W-0 |
| — | C1IP<2:0> ⁽¹⁾ | | | — | C1RXIP<2:0> ⁽¹⁾ | | |
| bit 15 | | | | bit 8 | | | |

| | | | | | | | |
|-------|-------------|-------|-------|-------|--------------|-------|-------|
| U-0 | R/W-1 | R/W-0 | R/W-0 | U-0 | R/W-1 | R/W-0 | R/W-0 |
| — | SPI2IP<2:0> | | | — | SPI2EIP<2:0> | | |
| bit 7 | | | | bit 0 | | | |

Legend:

R = Readable bit W = Writable bit U = Unimplemented bit, read as '0'
 -n = Value at POR '1' = Bit is set '0' = Bit is cleared x = Bit is unknown

- bit 15 **Unimplemented:** Read as '0'
- bit 14-12 **C1IP<2:0>:** ECAN1 Event Interrupt Priority bits⁽¹⁾
 - 111 = Interrupt is Priority 7 (highest priority interrupt)
 -
 -
 -
 - 001 = Interrupt is Priority 1
 - 000 = Interrupt source is disabled
- bit 11 **Unimplemented:** Read as '0'
- bit 10-8 **C1RXIP<2:0>:** ECAN1 Receive Data Ready Interrupt Priority bits⁽¹⁾
 - 111 = Interrupt is Priority 7 (highest priority interrupt)
 -
 -
 -
 - 001 = Interrupt is Priority 1
 - 000 = Interrupt source is disabled
- bit 7 **Unimplemented:** Read as '0'
- bit 6-4 **SPI2IP<2:0>:** SPI2 Event Interrupt Priority bits
 - 111 = Interrupt is Priority 7 (highest priority interrupt)
 -
 -
 -
 - 001 = Interrupt is Priority 1
 - 000 = Interrupt source is disabled
- bit 3 **Unimplemented:** Read as '0'
- bit 2-0 **SPI2EIP<2:0>:** SPI2 Error Interrupt Priority bits
 - 111 = Interrupt is Priority 7 (highest priority interrupt)
 -
 -
 -
 - 001 = Interrupt is Priority 1
 - 000 = Interrupt source is disabled

Note 1: Interrupts are disabled on devices without ECAN™ modules.

dsPIC33FJ32GS406/606/608/610 and dsPIC33FJ64GS406/606/608/610

REGISTER 7-30: IPC9: INTERRUPT PRIORITY CONTROL REGISTER 9

| | | | | | | | |
|--------|-----|-----|-----|-----|------------|-------|-------|
| U-0 | U-0 | U-0 | U-0 | U-0 | R/W-1 | R/W-0 | R/W-0 |
| — | — | — | — | — | IC4IP<2:0> | | |
| bit 15 | | | | | bit 8 | | |

| | | | | | | | |
|-------|------------|-------|-------|-----|-------------|-------|-------|
| U-0 | R/W-1 | R/W-0 | R/W-0 | U-0 | R/W-1 | R/W-0 | R/W-0 |
| — | IC3IP<2:0> | | | — | DMA3IP<2:0> | | |
| bit 7 | | | | | bit 0 | | |

Legend:

R = Readable bit W = Writable bit U = Unimplemented bit, read as '0'
 -n = Value at POR '1' = Bit is set '0' = Bit is cleared x = Bit is unknown

- bit 15-11 **Unimplemented:** Read as '0'
- bit 10-8 **IC4IP<2:0>:** Input Capture Channel 4 Interrupt Priority bits
 - 111 = Interrupt is Priority 7 (highest priority interrupt)
 -
 -
 -
 - 001 = Interrupt is Priority 1
 - 000 = Interrupt source is disabled
- bit 7 **Unimplemented:** Read as '0'
- bit 6-4 **IC3IP<2:0>:** Input Capture Channel 3 Interrupt Priority bits
 - 111 = Interrupt is Priority 7 (highest priority interrupt)
 -
 -
 -
 - 001 = Interrupt is Priority 1
 - 000 = Interrupt source is disabled
- bit 3 **Unimplemented:** Read as '0'
- bit 2-0 **DMA3IP<2:0>:** DMA Channel 3 Data Transfer Complete Interrupt Priority bits
 - 111 = Interrupt is Priority 7 (highest priority interrupt)
 -
 -
 -
 - 001 = Interrupt is Priority 1
 - 000 = Interrupt source is disabled

dsPIC33FJ32GS406/606/608/610 and dsPIC33FJ64GS406/606/608/610

REGISTER 7-31: IPC12: INTERRUPT PRIORITY CONTROL REGISTER 12

| | | | | | | | |
|--------|-----|-----|-----|-----|--------------|-------|-------|
| U-0 | U-0 | U-0 | U-0 | U-0 | R/W-1 | R/W-0 | R/W-0 |
| — | — | — | — | — | MI2C2IP<2:0> | | |
| bit 15 | | | | | bit 8 | | |

| | | | | | | | |
|-------|--------------|-------|-------|-------|-----|-----|-----|
| U-0 | R/W-1 | R/W-0 | R/W-0 | U-0 | U-0 | U-0 | U-0 |
| — | SI2C2IP<2:0> | | | — | — | — | — |
| bit 7 | | | | bit 0 | | | |

Legend:

R = Readable bit

W = Writable bit

U = Unimplemented bit, read as '0'

-n = Value at POR

'1' = Bit is set

'0' = Bit is cleared

x = Bit is unknown

bit 15-11 **Unimplemented:** Read as '0'

bit 10-8 **MI2C2IP<2:0>:** I2C2 Master Events Interrupt Priority bits

111 = Interrupt is Priority 7 (highest priority interrupt)

•

•

•

001 = Interrupt is Priority 1

000 = Interrupt source is disabled

bit 7 **Unimplemented:** Read as '0'

bit 6-4 **SI2C2IP<2:0>:** I2C2 Slave Events Interrupt Priority bits

111 = Interrupt is Priority 7 (highest priority interrupt)

•

•

•

001 = Interrupt is Priority 1

000 = Interrupt source is disabled

bit 3-0 **Unimplemented:** Read as '0'

dsPIC33FJ32GS406/606/608/610 and dsPIC33FJ64GS406/606/608/610

REGISTER 7-32: IPC13: INTERRUPT PRIORITY CONTROL REGISTER 13

| | | | | | | | |
|--------|-----|-----|-----|-----|-------------|-------|-------|
| U-0 | U-0 | U-0 | U-0 | U-0 | R/W-1 | R/W-0 | R/W-0 |
| — | — | — | — | — | INT4IP<2:0> | | |
| bit 15 | | | | | bit 8 | | |

| | | | | | | | |
|-------|-------------|-------|-------|-------|-----|-----|-----|
| U-0 | R/W-1 | R/W-0 | R/W-0 | U-0 | U-0 | U-0 | U-0 |
| — | INT3IP<2:0> | | | — | — | — | — |
| bit 7 | | | | bit 0 | | | |

Legend:

R = Readable bit

W = Writable bit

U = Unimplemented bit, read as '0'

-n = Value at POR

'1' = Bit is set

'0' = Bit is cleared

x = Bit is unknown

bit 15-11 **Unimplemented:** Read as '0'

bit 10-8 **INT4IP<2:0>:** External Interrupt 4 Priority bits
 111 = Interrupt is Priority 7 (highest priority interrupt)
 •
 •
 •
 001 = Interrupt is Priority 1
 000 = Interrupt source is disabled

bit 7 **Unimplemented:** Read as '0'

bit 6-4 **INT3IP<2:0>:** External Interrupt 3 Priority bits
 111 = Interrupt is Priority 7 (highest priority interrupt)
 •
 •
 •
 001 = Interrupt is Priority 1
 000 = Interrupt source is disabled

bit 3-0 **Unimplemented:** Read as '0'

dsPIC33FJ32GS406/606/608/610 and dsPIC33FJ64GS406/606/608/610

REGISTER 7-33: IPC14: INTERRUPT PRIORITY CONTROL REGISTER 14

| | | | | | | | |
|--------|-----|-----|-----|-----|-------------|-------|-------|
| U-0 | U-0 | U-0 | U-0 | U-0 | R/W-1 | R/W-0 | R/W-0 |
| — | — | — | — | — | QE11IP<2:0> | | |
| bit 15 | | | | | bit 8 | | |

| | | | | | | | |
|-------|-------------|-------|-------|-------|-----|-----|-----|
| U-0 | R/W-1 | R/W-0 | R/W-0 | U-0 | U-0 | U-0 | U-0 |
| — | PSEMIP<2:0> | | | — | — | — | — |
| bit 7 | | | | bit 0 | | | |

Legend:

R = Readable bit W = Writable bit U = Unimplemented bit, read as '0'
 -n = Value at POR '1' = Bit is set '0' = Bit is cleared x = Bit is unknown

- bit 15-11 **Unimplemented:** Read as '0'
- bit 10-8 **QE11IP<2:0>:** QE11 Interrupt Priority bits
 - 111 = Interrupt is Priority 7 (highest priority interrupt)
 -
 -
 -
 - 001 = Interrupt is Priority 1
 - 000 = Interrupt source is disabled
- bit 7 **Unimplemented:** Read as '0'
- bit 6-4 **PSEMIP<2:0>:** PWM Special Event Match Interrupt Priority bits
 - 111 = Interrupt is Priority 7 (highest priority interrupt)
 -
 -
 -
 - 001 = Interrupt is Priority 1
 - 000 = Interrupt source is disabled
- bit 3-0 **Unimplemented:** Read as '0'

dsPIC33FJ32GS406/606/608/610 and dsPIC33FJ64GS406/606/608/610

REGISTER 7-34: IPC16: INTERRUPT PRIORITY CONTROL REGISTER 16

| | | | | | | | |
|--------|-----|-----|-----|-----|------------|-------|-------|
| U-0 | U-0 | U-0 | U-0 | U-0 | R/W-1 | R/W-0 | R/W-0 |
| — | — | — | — | — | U2EIP<2:0> | | |
| bit 15 | | | | | bit 8 | | |

| | | | | | | | |
|-------|------------|-------|-------|-------|-----|-----|-----|
| U-0 | R/W-1 | R/W-0 | R/W-0 | U-0 | U-0 | U-0 | U-0 |
| — | U1EIP<2:0> | | | — | — | — | — |
| bit 7 | | | | bit 0 | | | |

Legend:

| | | |
|-------------------|------------------|------------------------------------|
| R = Readable bit | W = Writable bit | U = Unimplemented bit, read as '0' |
| -n = Value at POR | '1' = Bit is set | '0' = Bit is cleared |
| | | x = Bit is unknown |

- bit 15-11 **Unimplemented:** Read as '0'
- bit 10-8 **U2EIP<2:0>:** UART2 Error Interrupt Priority bits
 111 = Interrupt is Priority 7 (highest priority interrupt)
 •
 •
 •
 001 = Interrupt is Priority 1
 000 = Interrupt source is disabled
- bit 7 **Unimplemented:** Read as '0'
- bit 6-4 **U1EIP<2:0>:** UART1 Error Interrupt Priority bits
 111 = Interrupt is Priority 7 (highest priority interrupt)
 •
 •
 •
 001 = Interrupt is Priority 1
 000 = Interrupt source is disabled
- bit 3-0 **Unimplemented:** Read as '0'

dsPIC33FJ32GS406/606/608/610 and dsPIC33FJ64GS406/606/608/610

REGISTER 7-35: IPC17: INTERRUPT PRIORITY CONTROL REGISTER 17

| | | | | | | | |
|--------|-----|-----|-----|-----|----------------------------|-------|-------|
| U-0 | U-0 | U-0 | U-0 | U-0 | R/W-1 | R/W-0 | R/W-0 |
| — | — | — | — | — | C1TXIP<2:0> ⁽¹⁾ | | |
| bit 15 | | | | | bit 8 | | |

| | | | | | | | |
|-------|-----|-----|-----|-----|-------|-----|-----|
| U-0 | U-0 | U-0 | U-0 | U-0 | U-0 | U-0 | U-0 |
| — | — | — | — | — | — | — | — |
| bit 7 | | | | | bit 0 | | |

Legend:

R = Readable bit

W = Writable bit

U = Unimplemented bit, read as '0'

-n = Value at POR

'1' = Bit is set

'0' = Bit is cleared

x = Bit is unknown

bit 15-11 **Unimplemented:** Read as '0'

bit 10-8 **C1TXIP<2:0>:** ECAN1 Transmit Data Request Interrupt Priority bits⁽¹⁾

111 = Interrupt is Priority 7 (highest priority interrupt)

•

•

•

001 = Interrupt is Priority 1

000 = Interrupt source is disabled

bit 7-0 **Unimplemented:** Read as '0'

Note 1: Interrupts are disabled on devices without ECAN™ modules.

dsPIC33FJ32GS406/606/608/610 and dsPIC33FJ64GS406/606/608/610

REGISTER 7-36: IPC18: INTERRUPT PRIORITY CONTROL REGISTER 18

| | | | | | | | |
|--------|-------------|-------|-------|-------|-----|-----|-----|
| U-0 | R/W-1 | R/W-0 | R/W-0 | U-0 | U-0 | U-0 | U-0 |
| — | QEI2IP<2:0> | | | — | — | — | — |
| bit 15 | | | | bit 8 | | | |

| | | | | | | | |
|-------|--------------|-------|-------|-------|-----|-----|-----|
| U-0 | R/W-1 | R/W-0 | R/W-0 | U-0 | U-0 | U-0 | U-0 |
| — | PSESMIP<2:0> | | | — | — | — | — |
| bit 7 | | | | bit 0 | | | |

Legend:

R = Readable bit

W = Writable bit

U = Unimplemented bit, read as '0'

-n = Value at POR

'1' = Bit is set

'0' = Bit is cleared

x = Bit is unknown

bit 15 **Unimplemented:** Read as '0'

bit 14-12 **QEI2IP<2:0>:** QEI2 Interrupt Priority bits

111 = Interrupt is Priority 7 (highest priority interrupt)

•
•
•

001 = Interrupt is Priority 1

000 = Interrupt source is disabled

bit 11-7 **Unimplemented:** Read as '0'

bit 6-4 **PSESMIP<2:0>:** PWM Special Event Secondary Match Interrupt Priority bits

111 = Interrupt is Priority 7 (highest priority interrupt)

•
•
•

001 = Interrupt is Priority 1

000 = Interrupt source is disabled

bit 3-0 **Unimplemented:** Read as '0'

dsPIC33FJ32GS406/606/608/610 and dsPIC33FJ64GS406/606/608/610

REGISTER 7-37: IPC20: INTERRUPT PRIORITY CONTROL REGISTER 20

| | | | | | | | |
|--------|---------------|-------|-------|-------|--------------|-------|-------|
| U-0 | R/W-1 | R/W-0 | R/W-0 | U-0 | R/W-1 | R/W-0 | R/W-0 |
| — | ADCP10IP<2:0> | | | — | ADCP9IP<2:0> | | |
| bit 15 | | | | bit 8 | | | |

| | | | | | | | |
|-------|--------------|-------|-------|-------|-----|-----|-----|
| U-0 | R/W-1 | R/W-0 | R/W-0 | U-0 | U-0 | U-0 | U-0 |
| — | ADCP8IP<2:0> | | | — | — | — | — |
| bit 7 | | | | bit 0 | | | |

Legend:

R = Readable bit W = Writable bit U = Unimplemented bit, read as '0'
 -n = Value at POR '1' = Bit is set '0' = Bit is cleared x = Bit is unknown

- bit 15 **Unimplemented:** Read as '0'
- bit 14-12 **ADCP10IP<2:0>:** ADC Pair 10 Conversion Done Interrupt 1 Priority bits
 - 111 = Interrupt is Priority 7 (highest priority interrupt)
 -
 -
 -
 - 001 = Interrupt is Priority 1
 - 000 = Interrupt source is disabled
- bit 11 **Unimplemented:** Read as '0'
- bit 10-8 **ADCP9IP<2:0>:** ADC Pair 9 Conversion Done Interrupt 1 Priority bits
 - 111 = Interrupt is Priority 7 (highest priority interrupt)
 -
 -
 -
 - 001 = Interrupt is Priority 1
 - 000 = Interrupt source is disabled
- bit 7 **Unimplemented:** Read as '0'
- bit 6-4 **ADCP8IP<2:0>:** ADC Pair 8 Conversion Done Interrupt 1 Priority bits
 - 111 = Interrupt is Priority 7 (highest priority interrupt)
 -
 -
 -
 - 001 = Interrupt is Priority 1
 - 000 = Interrupt source is disabled
- bit 3-0 **Unimplemented:** Read as '0'

dsPIC33FJ32GS406/606/608/610 and dsPIC33FJ64GS406/606/608/610

REGISTER 7-38: IPC21: INTERRUPT PRIORITY CONTROL REGISTER 21

| | | | | | | | |
|--------|-----|-----|-----|-----|-----|-----|-------|
| U-0 | U-0 | U-0 | U-0 | U-0 | U-0 | U-0 | U-0 |
| — | — | — | — | — | — | — | — |
| bit 15 | | | | | | | bit 8 |

| | | | | | | | |
|-------|---------------|-------|-------|-----|-------|-------|-------|
| U-0 | R/W-1 | R/W-0 | R/W-0 | U-0 | R/W-1 | R/W-0 | R/W-0 |
| — | ADCP12IP<2:0> | | | — | — | — | — |
| bit 7 | | | | | | | bit 0 |

Legend:

R = Readable bit

W = Writable bit

U = Unimplemented bit, read as '0'

-n = Value at POR

'1' = Bit is set

'0' = Bit is cleared

x = Bit is unknown

bit 15-7 **Unimplemented:** Read as '0'

bit 6-4 **ADCP12IP<2:0>:** ADC Pair 12 Conversion Done Interrupt 1 Priority bits

111 = Interrupt is Priority 7 (highest priority interrupt)

•

•

•

001 = Interrupt is Priority 1

000 = Interrupt source is disabled

bit 3-0 **Unimplemented:** Read as '0'

dsPIC33FJ32GS406/606/608/610 and dsPIC33FJ64GS406/606/608/610

REGISTER 7-39: IPC23: INTERRUPT PRIORITY CONTROL REGISTER 23

| | | | | | | | |
|--------|-------------|-------|-------|-------|-------------|-------|-------|
| U-0 | R/W-1 | R/W-0 | R/W-0 | U-0 | R/W-1 | R/W-0 | R/W-0 |
| — | PWM2IP<2:0> | | | — | PWM1IP<2:0> | | |
| bit 15 | | | | bit 8 | | | |

| | | | | | | | |
|-------|-----|-----|-----|-----|-----|-----|-------|
| U-0 | U-0 | U-0 | U-0 | U-0 | U-0 | U-0 | U-0 |
| — | — | — | — | — | — | — | — |
| bit 7 | | | | | | | bit 0 |

Legend:

R = Readable bit W = Writable bit U = Unimplemented bit, read as '0'
 -n = Value at POR '1' = Bit is set '0' = Bit is cleared x = Bit is unknown

- bit 15 **Unimplemented:** Read as '0'
- bit 14-12 **PWM2IP<2:0>:** PWM2 Interrupt Priority bits
 - 111 = Interrupt is Priority 7 (highest priority)
 -
 -
 -
 - 001 = Interrupt is Priority 1
 - 000 = Interrupt source is disabled
- bit 11 **Unimplemented:** Read as '0'
- bit 10-8 **PWM1IP<2:0>:** PWM1 Interrupt Priority bits
 - 111 = Interrupt is Priority 7 (highest priority)
 -
 -
 -
 - 001 = Interrupt is Priority 1
 - 000 = Interrupt source is disabled
- bit 7-0 **Unimplemented:** Read as '0'

dsPIC33FJ32GS406/606/608/610 and dsPIC33FJ64GS406/606/608/610

REGISTER 7-40: IPC24: INTERRUPT PRIORITY CONTROL REGISTER 24

| | | | | | | | |
|--------|-------------|-------|-------|-------|-------------|-------|-------|
| U-0 | R/W-1 | R/W-0 | R/W-0 | U-0 | R/W-1 | R/W-0 | R/W-0 |
| — | PWM6IP<2:0> | | | — | PWM5IP<2:0> | | |
| bit 15 | | | | bit 8 | | | |

| | | | | | | | |
|-------|-------------|-------|-------|-------|-------------|-------|-------|
| U-0 | R/W-1 | R/W-0 | R/W-0 | U-0 | R/W-1 | R/W-0 | R/W-0 |
| — | PWM4IP<2:0> | | | — | PWM3IP<2:0> | | |
| bit 7 | | | | bit 0 | | | |

Legend:

R = Readable bit W = Writable bit U = Unimplemented bit, read as '0'
 -n = Value at POR '1' = Bit is set '0' = Bit is cleared x = Bit is unknown

- bit 15 **Unimplemented:** Read as '0'
- bit 14-12 **PWM6IP<2:0>:** PWM6 Interrupt Priority bits
 - 111 = Interrupt is Priority 7 (highest priority)
 -
 -
 -
 - 001 = Interrupt is Priority 1
 - 000 = Interrupt source is disabled
- bit 11 **Unimplemented:** Read as '0'
- bit 10-8 **PWM5IP<2:0>:** PWM5 Interrupt Priority bits
 - 111 = Interrupt is Priority 7 (highest priority)
 -
 -
 -
 - 001 = Interrupt is Priority 1
 - 000 = Interrupt source is disabled
- bit 7 **Unimplemented:** Read as '0'
- bit 6-4 **PWM4IP<2:0>:** PWM4 Interrupt Priority bits
 - 111 = Interrupt is Priority 7 (highest priority)
 -
 -
 -
 - 001 = Interrupt is Priority 1
 - 000 = Interrupt source is disabled
- bit 3 **Unimplemented:** Read as '0'
- bit 2-0 **PWM3IP<2:0>:** PWM3 Interrupt Priority bits
 - 111 = Interrupt is Priority 7 (highest priority)
 -
 -
 -
 - 001 = Interrupt is Priority 1
 - 000 = Interrupt source is disabled

dsPIC33FJ32GS406/606/608/610 and dsPIC33FJ64GS406/606/608/610

REGISTER 7-41: IPC25: INTERRUPT PRIORITY CONTROL REGISTER 25

| | | | | | | | |
|--------|------------|-------|-------|-------|-------------|-------|-------|
| U-0 | R/W-1 | R/W-0 | R/W-0 | U-0 | R/W-1 | R/W-0 | R/W-0 |
| — | AC2IP<2:0> | | | — | PWM9IP<2:0> | | |
| bit 15 | | | | bit 8 | | | |

| | | | | | | | |
|-------|-------------|-------|-------|-------|-------------|-------|-------|
| U-0 | R/W-1 | R/W-0 | R/W-0 | U-0 | R/W-1 | R/W-0 | R/W-0 |
| — | PWM8IP<2:0> | | | — | PWM7IP<2:0> | | |
| bit 7 | | | | bit 0 | | | |

Legend:

R = Readable bit W = Writable bit U = Unimplemented bit, read as '0'
 -n = Value at POR '1' = Bit is set '0' = Bit is cleared x = Bit is unknown

- bit 15 **Unimplemented:** Read as '0'
- bit 14-12 **AC2IP<2:0>:** Analog Comparator 2 Interrupt Priority bits
 - 111 = Interrupt is Priority 7 (highest priority)
 -
 -
 -
 - 001 = Interrupt is Priority 1
 - 000 = Interrupt source is disabled
- bit 11 **Unimplemented:** Read as '0'
- bit 10-8 **PWM9IP<2:0>:** PWM9 Interrupt Priority bits
 - 111 = Interrupt is Priority 7 (highest priority)
 -
 -
 -
 - 001 = Interrupt is Priority 1
 - 000 = Interrupt source is disabled
- bit 7 **Unimplemented:** Read as '0'
- bit 6-4 **PWM8IP<2:0>:** PWM8 Interrupt Priority bits
 - 111 = Interrupt is Priority 7 (highest priority)
 -
 -
 -
 - 001 = Interrupt is Priority 1
 - 000 = Interrupt source is disabled
- bit 3 **Unimplemented:** Read as '0'
- bit 2-0 **PWM7IP<2:0>:** PWM7 Interrupt Priority bits
 - 111 = Interrupt is Priority 7 (highest priority)
 -
 -
 -
 - 001 = Interrupt is Priority 1
 - 000 = Interrupt source is disabled

dsPIC33FJ32GS406/606/608/610 and dsPIC33FJ64GS406/606/608/610

REGISTER 7-42: IPC26: INTERRUPT PRIORITY CONTROL REGISTER 26

| | | | | | | | |
|--------|-----|-----|-----|-----|-----|-------|-----|
| U-0 | U-0 | U-0 | U-0 | U-0 | U-0 | U-0 | U-0 |
| — | — | — | — | — | — | — | — |
| bit 15 | | | | | | bit 8 | |

| | | | | | | | |
|-------|------------|-------|-------|-------|------------|-------|-------|
| U-0 | R/W-1 | R/W-0 | R/W-0 | U-0 | R/W-1 | R/W-0 | R/W-0 |
| — | AC4IP<2:0> | | | — | AC3IP<2:0> | | |
| bit 7 | | | | bit 0 | | | |

Legend:

R = Readable bit W = Writable bit U = Unimplemented bit, read as '0'
 -n = Value at POR '1' = Bit is set '0' = Bit is cleared x = Bit is unknown

bit 15-7 **Unimplemented:** Read as '0'

bit 6-4 **AC4IP<2:0>:** Analog Comparator 4 Interrupt Priority bits

111 = Interrupt is Priority 7 (highest priority)

-
-
-

001 = Interrupt is Priority 1

000 = Interrupt source is disabled

bit 3 **Unimplemented:** Read as '0'

bit 2-0 **AC3IP<2:0>:** Analog Comparator 3 Interrupt Priority bits

111 = Interrupt is Priority 7 (highest priority)

-
-
-

001 = Interrupt is Priority 1

000 = Interrupt source is disabled

dsPIC33FJ32GS406/606/608/610 and dsPIC33FJ64GS406/606/608/610

REGISTER 7-43: IPC27: INTERRUPT PRIORITY CONTROL REGISTER 27

| | | | | | | | |
|--------|--------------|-------|-------|-------|--------------|-------|-------|
| U-0 | R/W-1 | R/W-0 | R/W-0 | U-0 | R/W-1 | R/W-0 | R/W-0 |
| — | ADCP1IP<2:0> | | | — | ADCP0IP<2:0> | | |
| bit 15 | | | | bit 8 | | | |

| | | | | | | | |
|-------|-----|-----|-----|-----|-----|-----|-------|
| U-0 | U-0 | U-0 | U-0 | U-0 | U-0 | U-0 | U-0 |
| — | — | — | — | — | — | — | — |
| bit 7 | | | | | | | bit 0 |

Legend:

R = Readable bit W = Writable bit U = Unimplemented bit, read as '0'
 -n = Value at POR '1' = Bit is set '0' = Bit is cleared x = Bit is unknown

- bit 15 **Unimplemented:** Read as '0'
- bit 14-12 **ADCP1IP<2:0>:** ADC Pair 1 Conversion Done Interrupt Priority bits
 111 = Interrupt is Priority 7 (highest priority interrupt)
 •
 •
 •
 001 = Interrupt is Priority 1
 000 = Interrupt source is disabled
- bit 11 **Unimplemented:** Read as '0'
- bit 10-8 **ADCP0IP<2:0>:** ADC Pair 0 Conversion Done Interrupt Priority bits
 111 = Interrupt is Priority 7 (highest priority interrupt)
 •
 •
 •
 001 = Interrupt is Priority 1
 000 = Interrupt source is disabled
- bit 7-0 **Unimplemented:** Read as '0'

dsPIC33FJ32GS406/606/608/610 and dsPIC33FJ64GS406/606/608/610

REGISTER 7-44: IPC28: INTERRUPT PRIORITY CONTROL REGISTER 28

| | | | | | | | |
|--------|--------------|-------|-------|-------|--------------|-------|-------|
| U-0 | R/W-1 | R/W-0 | R/W-0 | U-0 | R/W-1 | R/W-0 | R/W-0 |
| — | ADCP5IP<2:0> | | | — | ADCP4IP<2:0> | | |
| bit 15 | | | | bit 8 | | | |

| | | | | | | | |
|-------|--------------|-------|-------|-------|--------------|-------|-------|
| U-0 | R/W-1 | R/W-0 | R/W-0 | U-0 | R/W-1 | R/W-0 | R/W-0 |
| — | ADCP3IP<2:0> | | | — | ADCP2IP<2:0> | | |
| bit 7 | | | | bit 0 | | | |

Legend:

R = Readable bit W = Writable bit U = Unimplemented bit, read as '0'
 -n = Value at POR '1' = Bit is set '0' = Bit is cleared x = Bit is unknown

- bit 15 **Unimplemented:** Read as '0'
- bit 14-12 **ADCP5IP<2:0>:** ADC Pair 5 Conversion Done Interrupt Priority bits
 - 111 = Interrupt is Priority 7 (highest priority interrupt)
 -
 -
 -
 - 001 = Interrupt is Priority 1
 - 000 = Interrupt source is disabled
- bit 11 **Unimplemented:** Read as '0'
- bit 10-8 **ADCP4IP<2:0>:** ADC Pair 4 Conversion Done Interrupt Priority bits
 - 111 = Interrupt is Priority 7 (highest priority interrupt)
 -
 -
 -
 - 001 = Interrupt is Priority 1
 - 000 = Interrupt source is disabled
- bit 7 **Unimplemented:** Read as '0'
- bit 6-4 **ADCP3IP<2:0>:** ADC Pair 3 Conversion Done Interrupt Priority bits
 - 111 = Interrupt is Priority 7 (highest priority interrupt)
 -
 -
 -
 - 001 = Interrupt is Priority 1
 - 000 = Interrupt source is disabled
- bit 3 **Unimplemented:** Read as '0'
- bit 2-0 **ADCP2IP<2:0>:** ADC Pair 2 Conversion Done Interrupt Priority bits
 - 111 = Interrupt is Priority 7 (highest priority interrupt)
 -
 -
 -
 - 001 = Interrupt is Priority 1
 - 000 = Interrupt source is disabled

dsPIC33FJ32GS406/606/608/610 and dsPIC33FJ64GS406/606/608/610

REGISTER 7-45: IPC29: INTERRUPT PRIORITY CONTROL REGISTER 29

| | | | | | | | |
|--------|-----|-----|-----|-----|-----|-----|-------|
| U-0 | U-0 | U-0 | U-0 | U-0 | U-0 | U-0 | U-0 |
| — | — | — | — | — | — | — | — |
| bit 15 | | | | | | | bit 8 |

| | | | | | | | |
|-------|--------------|-------|-------|-----|--------------|-------|-------|
| U-0 | R/W-1 | R/W-0 | R/W-0 | U-0 | R/W-1 | R/W-0 | R/W-0 |
| — | ADCP7IP<2:0> | | | — | ADCP6IP<2:0> | | |
| bit 7 | | | | | | | bit 0 |

Legend:

R = Readable bit W = Writable bit U = Unimplemented bit, read as '0'
 -n = Value at POR '1' = Bit is set '0' = Bit is cleared x = Bit is unknown

- bit 15-7 **Unimplemented:** Read as '0'
- bit 6-4 **ADCP7IP<2:0>:** ADC Pair 7 Conversion Done Interrupt 1 Priority bits
 111 = Interrupt is Priority 7 (highest priority interrupt)
 •
 •
 •
 001 = Interrupt is Priority 1
 000 = Interrupt source is disabled
- bit 3 **Unimplemented:** Read as '0'
- bit 2-0 **ADCP6IP<2:0>:** ADC Pair 6 Conversion Done Interrupt 1 Priority bits
 111 = Interrupt is Priority 7 (highest priority interrupt)
 •
 •
 •
 001 = Interrupt is Priority 1
 000 = Interrupt source is disabled

dsPIC33FJ32GS406/606/608/610 and dsPIC33FJ64GS406/606/608/610

REGISTER 7-46: INTTREG: INTERRUPT CONTROL AND STATUS REGISTER

| | | | | | | | |
|--------|-----|-----|-----|----------|-----|-----|-----|
| U-0 | U-0 | U-0 | U-0 | R-0 | R-0 | R-0 | R-0 |
| — | — | — | — | ILR<3:0> | | | |
| bit 15 | | | | bit 8 | | | |

| | | | | | | | |
|-------|-------------|-----|-----|-------|-----|-----|-----|
| U-0 | R-0 | R-0 | R-0 | R-0 | R-0 | R-0 | R-0 |
| — | VECNUM<6:0> | | | | | | |
| bit 7 | | | | bit 0 | | | |

Legend:

| | | |
|-------------------|------------------|--|
| R = Readable bit | W = Writable bit | U = Unimplemented bit, read as '0' |
| -n = Value at POR | '1' = Bit is set | '0' = Bit is cleared x = Bit is unknown |

- bit 15-12 **Unimplemented:** Read as '0'
- bit 11-8 **ILR<3:0>:** New CPU Interrupt Priority Level bits
 - 1111 = CPU Interrupt Priority Level is 15
 -
 -
 -
 - 0001 = CPU Interrupt Priority Level is 1
 - 0000 = CPU Interrupt Priority Level is 0
- bit 7 **Unimplemented:** Read as '0'
- bit 6-0 **VECNUM<6:0>:** Vector Number of Pending Interrupt bits
 - 0111111 = Interrupt vector pending is Number 135
 -
 -
 -
 - 0000001 = Interrupt vector pending is Number 9
 - 0000000 = Interrupt vector pending is Number 8

7.4 Interrupt Setup Procedures

7.4.1 INITIALIZATION

Complete the following steps to configure an interrupt source at initialization:

1. Set the NSTDIS bit (INTCON1<15>) if nested interrupts are not desired.
2. Select the user-assigned priority level for the interrupt source by writing the control bits in the appropriate IPCx register. The priority level will depend on the specific application and type of interrupt source. If multiple priority levels are not desired, the IPCx register control bits for all enabled interrupt sources can be programmed to the same non-zero value.

Note: At a device Reset, the IPCx registers are initialized such that all user interrupt sources are assigned to Priority Level 4.

3. Clear the interrupt flag status bit associated with the peripheral in the associated IFSx register.
4. Enable the interrupt source by setting the interrupt enable control bit associated with the source in the appropriate IECx register.

7.4.2 INTERRUPT SERVICE ROUTINE

The method used to declare an ISR and initialize the IVT with the correct vector address depends on the programming language (C or assembler) and the language development toolsuite used to develop the application.

In general, the user application must clear the interrupt flag in the appropriate IFSx register for the source of interrupt that the ISR handles. Otherwise, program will re-enter the ISR immediately after exiting the routine. If the ISR is coded in assembly language, it must be terminated using a `RETFIE` instruction to unstack the saved PC value, SRL value and old CPU priority level.

7.4.3 TRAP SERVICE ROUTINE

A Trap Service Routine (TSR) is coded like an ISR, except that the appropriate trap status flag in the INTCON1 register must be cleared to avoid re-entry into the TSR.

7.4.4 INTERRUPT DISABLE

The following steps outline the procedure to disable all user interrupts:

1. Push the current SR value onto the software stack using the `PUSH` instruction.
2. Force the CPU to Priority Level 7 by inclusive ORing the value EOh with SRL.

To enable user interrupts, the `POP` instruction can be used to restore the previous SR value.

Note: Only user interrupts with a priority level of 7 or lower can be disabled. Trap sources (Level 8-Level 15) cannot be disabled.

The `DISI` instruction provides a convenient way to disable interrupts of Priority Levels 1-6 for a fixed period of time. Level 7 interrupt sources are not disabled by the `DISI` instruction.

8.0 DIRECT MEMORY ACCESS (DMA)

Note 1: This data sheet summarizes the features of the dsPIC33FJ32GS406/606/608/610 and dsPIC33FJ64GS406/606/608/610 family of devices. However, it is not intended to be a comprehensive reference source. To complement the information in this data sheet, refer to **Section 22. “Direct Memory Access (DMA)”** (DS70182) in the “dsPIC33F/PIC24H Family Reference Manual”, which is available from the Microchip web site (www.microchip.com).

2: Some registers and associated bits described in this section may not be available on all devices. Refer to **Section 4.0 “Memory Organization”** in this data sheet for device-specific register and bit information.

Direct Memory Access (DMA) is a very efficient mechanism of copying data between peripheral SFRs (e.g., the UART Receive register and Input Capture 1 buffer) and buffers or variables stored in RAM, with minimal CPU intervention. The DMA Controller (DMAC) can automatically copy entire blocks of data without requiring the user software to read or write the peripheral Special Function Registers (SFRs) every time a peripheral interrupt occurs. The DMA Controller uses a dedicated bus for data transfers and, therefore, does not steal cycles from the code execution flow of the CPU. To exploit the DMA capability, the corresponding user buffers or variables must be located in DMA RAM.

Note: The DMA module is not available on dsPIC33FJ32GS406/606/608/610 and dsPIC33FJ64GS406 devices.

The peripherals that can utilize DMA are listed in **Table 8-1** along with their associated Interrupt Request (IRQ) numbers.

TABLE 8-1: DMA CONTROLLER CHANNEL TO PERIPHERAL ASSOCIATIONS

| Peripheral to DMA Association | DMAxREQ Register IRQSEL<6:0> Bits | DMAxPAD Register Values to Read from Peripheral | DMAxPAD Register Values to Write to Peripheral |
|---------------------------------------|-----------------------------------|---|--|
| INT0 – External Interrupt 0 | 0000000 | — | — |
| IC1 – Input Capture 1 | 0000001 | 0x0140 (IC1BUF) | — |
| IC2 – Input Capture 2 | 0000101 | 0x0144 (IC2BUF) | — |
| IC3 – Input Capture 3 | 0100101 | 0x0148 (IC3BUF) | — |
| IC4 – Input Capture 4 | 0100110 | 0x014C (IC4BUF) | — |
| OC1 – Output Compare 1 Data | 0000010 | — | 0x0182 (OC1R) |
| OC1 – Output Compare 1 Secondary Data | 0000010 | — | 0x0180 (OC1RS) |
| OC2 – Output Compare 2 Data | 0000110 | — | 0x0188 (OC2R) |
| OC2 – Output Compare 2 Secondary Data | 0000110 | — | 0x0186 (OC2RS) |
| OC3 – Output Compare 3 Data | 0011001 | — | 0x018E (OC3R) |
| OC3 – Output Compare 3 Secondary Data | 0011001 | — | 0x018C (OC3RS) |
| OC4 – Output Compare 4 Data | 0011010 | — | 0x0194 (OC4R) |
| OC4 – Output Compare 4 Secondary Data | 0011010 | — | 0x0192 (OC4RS) |
| TMR2 – Timer2 | 0000111 | — | — |
| TMR3 – Timer3 | 0001000 | — | — |
| TMR4 – Timer4 | 0011011 | — | — |
| TMR5 – Timer5 | 0011100 | — | — |
| SPI1 – Transfer Done | 0001010 | 0x0248 (SPI1BUF) | 0x0248 (SPI1BUF) |
| SPI2 – Transfer Done | 0100001 | 0x0268 (SPI2BUF) | 0x0268 (SPI2BUF) |
| UART1RX – UART1 Receiver | 0001011 | 0x0226 (U1RXREG) | — |
| UART1TX – UART1 Transmitter | 0001100 | — | 0x0224 (U1TXREG) |
| UART2RX – UART2 Receiver | 0011110 | 0x0236 (U2RXREG) | — |
| UART2TX – UART2 Transmitter | 0011111 | — | 0x0234 (U2TXREG) |
| ECAN1 – RX Data Ready | 0100010 | 0x0640 (C1RXD) | — |
| ECAN1 – TX Data Request | 1000110 | — | 0x0642 (C1TXD) |

The DMA Controller features four identical data transfer channels. Each channel has its own set of control and status registers. Each DMA Channel can be configured to copy data either from buffers stored in dual port DMA RAM to peripheral SFRs or from peripheral SFRs to buffers in DMA RAM.

The DMA Controller supports the following features:

- Word or byte-sized data transfers.
- Transfers from peripheral to DMA RAM or DMA RAM to peripheral
- Indirect Addressing of DMA RAM locations with or without automatic post-increment
- Peripheral Indirect Addressing – In some peripherals, the DMA RAM read/write addresses may be partially derived from the peripheral
- One-Shot Block Transfers – Terminating DMA transfer after one block transfer
- Continuous Block Transfers – Reloading DMA RAM buffer start address after every block transfer is complete
- Ping-Pong Mode – Switching between two DMA RAM start addresses between successive block transfers, thereby filling two buffers alternately
- Automatic or manual initiation of block transfers

For each DMA Channel, a DMA interrupt request is generated when a block transfer is complete. Alternatively, an interrupt can be generated when half of the block has been filled.

8.1 DMAC Registers

Each DMAC Channel x ($x = 0, 1, 2$ or 3) contains the following registers:

- A 16-Bit DMA Channel Control Register (DMAxCON)
- A 16-Bit DMA Channel IRQ Select Register (DMAxREQ)
- A 16-Bit DMA RAM Primary Start Address Offset Register (DMAxSTA)
- A 16-Bit DMA RAM Secondary Start Address Offset Register (DMAxSTB)
- A 16-Bit DMA Peripheral Address Register (DMAxPAD)
- A 10-Bit DMA Transfer Count Register (DMAxCNT)

An additional pair of status registers, DMACCS0 and DMACCS1, are common to all DMAC channels.

FIGURE 8-1: TOP LEVEL SYSTEM ARCHITECTURE USING A DEDICATED TRANSACTION BUS



dsPIC33FJ32GS406/606/608/610 and dsPIC33FJ64GS406/606/608/610

REGISTER 8-1: DMAxCON: DMA CHANNEL x CONTROL REGISTER

| | | | | | | | |
|--------|-------|-------|-------|-------|-----|-------|-----|
| R/W-0 | R/W-0 | R/W-0 | R/W-0 | R/W-0 | U-0 | U-0 | U-0 |
| CHEN | SIZE | DIR | HALF | NULLW | — | — | — |
| bit 15 | | | | | | bit 8 | |

| | | | | | | | |
|-------|-----|------------|-------|-----|-----|-----------|-------|
| U-0 | U-0 | R/W-0 | R/W-0 | U-0 | U-0 | R/W-0 | R/W-0 |
| — | — | AMODE<1:0> | | — | — | MODE<1:0> | |
| bit 7 | | | | | | bit 0 | |

Legend:

R = Readable bit W = Writable bit U = Unimplemented bit, read as '0'
-n = Value at POR '1' = Bit is set '0' = Bit is cleared x = Bit is unknown

- bit 15 **CHEN:** DMA Channel Enable bit
 1 = Channel is enabled
 0 = Channel is disabled
- bit 14 **SIZE:** Data Transfer Size bit
 1 = Byte
 0 = Word
- bit 13 **DIR:** Transfer Direction bit (source/destination bus select)
 1 = Reads from DMA RAM address; writes to peripheral address
 0 = Reads from peripheral address; writes to DMA RAM address
- bit 12 **HALF:** Early Block Transfer Complete Interrupt Select bit
 1 = Initiates block transfer complete interrupt when half of the data has been moved
 0 = Initiates block transfer complete interrupt when all of the data has been moved
- bit 11 **NULLW:** Null Data Peripheral Write Mode Select bit
 1 = Null data write to peripheral in addition to DMA RAM write (DIR bit must also be clear)
 0 = Normal operation
- bit 10-6 **Unimplemented:** Read as '0'
- bit 5-4 **AMODE<1:0>:** DMA Channel Operating Mode Select bits
 11 = Reserved
 10 = Peripheral Indirect Addressing mode
 01 = Register Indirect without Post-Increment mode
 00 = Register Indirect with Post-Increment mode
- bit 3-2 **Unimplemented:** Read as '0'
- bit 1-0 **MODE<1:0>:** DMA Channel Operating Mode Select bits
 11 = One-Shot, Ping-Pong modes are enabled (one block transfer from/to each DMA RAM buffer)
 10 = Continuous, Ping-Pong modes are enabled
 01 = One-Shot, Ping-Pong modes are disabled
 00 = Continuous, Ping-Pong modes are disabled

dsPIC33FJ32GS406/606/608/610 and dsPIC33FJ64GS406/606/608/610

REGISTER 8-2: DMAxREQ: DMA CHANNEL x IRQ SELECT REGISTER

| | | | | | | | |
|----------------------|-----|-----|-----|-----|-----|-----|-------|
| R/W-0 | U-0 | U-0 | U-0 | U-0 | U-0 | U-0 | U-0 |
| FORCE ⁽¹⁾ | — | — | — | — | — | — | — |
| bit 15 | | | | | | | bit 8 |

| | | | | | | | |
|-------|----------------------------|-------|-------|-------|-------|-------|-------|
| U-0 | R/W-1 | R/W-1 | R/W-1 | R/W-1 | R/W-1 | R/W-1 | R/W-1 |
| — | IRQSEL<6:0> ⁽²⁾ | | | | | | — |
| bit 7 | | | | | | | bit 0 |

Legend:

R = Readable bit W = Writable bit U = Unimplemented bit, read as '0'
 -n = Value at POR '1' = Bit is set '0' = Bit is cleared x = Bit is unknown

bit 15 **FORCE:** Force DMA Transfer bit⁽¹⁾
 1 = Forces a single DMA transfer (Manual mode)
 0 = Automatic DMA transfer initiation by DMA request

bit 14-7 **Unimplemented:** Read as '0'

bit 6-0 **IRQSEL<6:0>:** DMA Peripheral IRQ Number Select bits⁽²⁾
 0000000-1111111 = DMAIRQ0-DMAIRQ127 are selected to be Channel DMAREQ

- Note 1:** The FORCE bit cannot be cleared by the user. The FORCE bit is cleared by hardware when the forced DMA transfer is complete.
- 2:** See [Table 8-1](#) for a complete listing of IRQ numbers for all interrupt sources.

REGISTER 8-3: DMAxSTA: DMA CHANNEL x RAM START ADDRESS OFFSET REGISTER A

| | | | | | | | |
|-----------|-------|-------|-------|-------|-------|-------|-------|
| R/W-0 | R/W-0 | R/W-0 | R/W-0 | R/W-0 | R/W-0 | R/W-0 | R/W-0 |
| STA<15:8> | | | | | | | — |
| bit 15 | | | | | | | bit 8 |

| | | | | | | | |
|----------|-------|-------|-------|-------|-------|-------|-------|
| R/W-0 | R/W-0 | R/W-0 | R/W-0 | R/W-0 | R/W-0 | R/W-0 | R/W-0 |
| STA<7:0> | | | | | | | — |
| bit 7 | | | | | | | bit 0 |

Legend:

R = Readable bit W = Writable bit U = Unimplemented bit, read as '0'
 -n = Value at POR '1' = Bit is set '0' = Bit is cleared x = Bit is unknown

bit 15-0 **STA<15:0>:** Primary DMA RAM Start Address bits (source or destination)

dsPIC33FJ32GS406/606/608/610 and dsPIC33FJ64GS406/606/608/610

REGISTER 8-4: DMAxSTB: DMA CHANNEL x RAM START ADDRESS OFFSET REGISTER B

| | | | | | | | |
|-----------|-------|-------|-------|-------|-------|-------|-------|
| R/W-0 | R/W-0 | R/W-0 | R/W-0 | R/W-0 | R/W-0 | R/W-0 | R/W-0 |
| STB<15:8> | | | | | | | |
| bit 15 | | | | bit 8 | | | |

| | | | | | | | |
|----------|-------|-------|-------|-------|-------|-------|-------|
| R/W-0 | R/W-0 | R/W-0 | R/W-0 | R/W-0 | R/W-0 | R/W-0 | R/W-0 |
| STB<7:0> | | | | | | | |
| bit 7 | | | | bit 0 | | | |

Legend:

R = Readable bit W = Writable bit U = Unimplemented bit, read as '0'
 -n = Value at POR '1' = Bit is set '0' = Bit is cleared x = Bit is unknown

bit 15-0 **STB<15:0>**: Secondary DMA RAM Start Address bits (source or destination)

REGISTER 8-5: DMAxPAD: DMA CHANNEL x PERIPHERAL ADDRESS REGISTER⁽¹⁾

| | | | | | | | |
|--------------------------|-------|-------|-------|-------|-------|-------|-------|
| R/W-0 | R/W-0 | R/W-0 | R/W-0 | R/W-0 | R/W-0 | R/W-0 | R/W-0 |
| PAD<15:8> ⁽²⁾ | | | | | | | |
| bit 15 | | | | bit 8 | | | |

| | | | | | | | |
|-------------------------|-------|-------|-------|-------|-------|-------|-------|
| R/W-0 | R/W-0 | R/W-0 | R/W-0 | R/W-0 | R/W-0 | R/W-0 | R/W-0 |
| PAD<7:0> ⁽²⁾ | | | | | | | |
| bit 7 | | | | bit 0 | | | |

Legend:

R = Readable bit W = Writable bit U = Unimplemented bit, read as '0'
 -n = Value at POR '1' = Bit is set '0' = Bit is cleared x = Bit is unknown

bit 15-0 **PAD<15:0>**: Peripheral Address Register bits⁽²⁾

Note 1: If the channel is enabled (i.e., active), writes to this register may result in unpredictable behavior of the DMA channel and should be avoided.

2: See [Table 8-1](#) for a complete list of peripheral addresses.

dsPIC33FJ32GS406/606/608/610 and dsPIC33FJ64GS406/606/608/610

REGISTER 8-6: DMAx_CNT: DMA CHANNEL x TRANSFER COUNT REGISTER⁽¹⁾

| | | | | | | | |
|--------|-----|-----|-----|-----|-----|-------------------------|-------|
| U-0 | U-0 | U-0 | U-0 | U-0 | U-0 | R/W-0 | R/W-0 |
| — | — | — | — | — | — | CNT<9:8> ⁽²⁾ | |
| bit 15 | | | | | | bit 8 | |

| | | | | | | | |
|-------------------------|-------|-------|-------|-------|-------|-------|-------|
| R/W-0 | R/W-0 | R/W-0 | R/W-0 | R/W-0 | R/W-0 | R/W-0 | R/W-0 |
| CNT<7:0> ⁽²⁾ | | | | | | | |
| bit 7 | | | | | | bit 0 | |

Legend:

R = Readable bit

W = Writable bit

U = Unimplemented bit, read as '0'

-n = Value at POR

'1' = Bit is set

'0' = Bit is cleared

x = Bit is unknown

bit 15-10 **Unimplemented:** Read as '0'

bit 9-0 **CNT<9:0>:** DMA Transfer Count Register bits⁽²⁾

Note 1: If the channel is enabled (i.e., active), writes to this register may result in unpredictable behavior of the DMA channel and should be avoided.

2: Number of DMA transfers = CNT<9:0> + 1.

dsPIC33FJ32GS406/606/608/610 and dsPIC33FJ64GS406/606/608/610

REGISTER 8-7: DMACS0: DMA CONTROLLER STATUS REGISTER 0

| | | | | | | | |
|--------|-----|-----|-----|--------|--------|--------|--------|
| U-0 | U-0 | U-0 | U-0 | R/C-0 | R/C-0 | R/C-0 | R/C-0 |
| — | — | — | — | PWCOL3 | PWCOL2 | PWCOL1 | PWCOL0 |
| bit 15 | | | | bit 8 | | | |

| | | | | | | | |
|-------|-----|-----|-----|--------|--------|--------|--------|
| U-0 | U-0 | U-0 | U-0 | R/C-0 | R/C-0 | R/C-0 | R/C-0 |
| — | — | — | — | XWCOL3 | XWCOL2 | XWCOL1 | XWCOL0 |
| bit 7 | | | | bit 0 | | | |

Legend:

R = Readable bit W = Writable bit U = Unimplemented bit, read as '0'
-n = Value at POR '1' = Bit is set '0' = Bit is cleared x = Bit is unknown

- bit 15-12 **Unimplemented:** Read as '0'
- bit 11 **PWCOL3:** Channel 3 Peripheral Write Collision Flag bit
1 = Write collision is detected
0 = No write collision is detected
- bit 10 **PWCOL2:** Channel 2 Peripheral Write Collision Flag bit
1 = Write collision is detected
0 = No write collision is detected
- bit 9 **PWCOL1:** Channel 1 Peripheral Write Collision Flag bit
1 = Write collision is detected
0 = No write collision is detected
- bit 8 **PWCOL0:** Channel 0 Peripheral Write Collision Flag bit
1 = Write collision is detected
0 = No write collision is detected
- bit 7-4 **Unimplemented:** Read as '0'
- bit 3 **XWCOL3:** Channel 3 DMA RAM Write Collision Flag bit
1 = Write collision is detected
0 = No write collision is detected
- bit 2 **XWCOL2:** Channel 2 DMA RAM Write Collision Flag bit
1 = Write collision is detected
0 = No write collision is detected
- bit 1 **XWCOL1:** Channel 1 DMA RAM Write Collision Flag bit
1 = Write collision is detected
0 = No write collision is detected
- bit 0 **XWCOL0:** Channel 0 DMA RAM Write Collision Flag bit
1 = Write collision is detected
0 = No write collision is detected

dsPIC33FJ32GS406/606/608/610 and dsPIC33FJ64GS406/606/608/610

REGISTER 8-8: DMACS1: DMA CONTROLLER STATUS REGISTER 1

| | | | | | | | |
|--------|-----|-----|-----|------------|-----|-----|-----|
| U-0 | U-0 | U-0 | U-0 | R-1 | R-1 | R-1 | R-1 |
| — | — | — | — | LSTCH<3:0> | | | |
| bit 15 | | | | bit 8 | | | |

| | | | | | | | |
|-------|-----|-----|-----|-------|-------|-------|-------|
| U-0 | U-0 | U-0 | U-0 | R-0 | R-0 | R-0 | R-0 |
| — | — | — | — | PPST3 | PPST2 | PPST1 | PPST0 |
| bit 7 | | | | bit 0 | | | |

Legend:

R = Readable bit

W = Writable bit

U = Unimplemented bit, read as '0'

-n = Value at POR

'1' = Bit is set

'0' = Bit is cleared

x = Bit is unknown

bit 15-12 **Unimplemented:** Read as '0'

bit 11-8 **LSTCH<3:0>:** Last DMA Channel Active bits

1111 = No DMA transfer has occurred since system Reset

1110 = Reserved

-
-
-

0100 = Reserved

0011 = Last data transfer was by DMA Channel 3

0010 = Last data transfer was by DMA Channel 2

0001 = Last data transfer was by DMA Channel 1

0000 = Last data transfer was by DMA Channel 0

bit 7-4 **Unimplemented:** Read as '0'

bit 3 **PPST3:** Channel 3 Ping-Pong Mode Status Flag bit

1 = DMA3STB register is selected

0 = DMA3STA register is selected

bit 2 **PPST2:** Channel 2 Ping-Pong Mode Status Flag bit

1 = DMA2STB register is selected

0 = DMA2STA register is selected

bit 1 **PPST1:** Channel 1 Ping-Pong Mode Status Flag bit

1 = DMA1STB register is selected

0 = DMA1STA register is selected

bit 0 **PPST0:** Channel 0 Ping-Pong Mode Status Flag bit

1 = DMA0STB register is selected

0 = DMA0STA register is selected

dsPIC33FJ32GS406/606/608/610 and dsPIC33FJ64GS406/606/608/610

REGISTER 8-9: DSADR: MOST RECENT DMA RAM ADDRESS

| | | | | | | | |
|-------------|-----|-----|-----|-------|-----|-----|-----|
| R-0 | R-0 | R-0 | R-0 | R-0 | R-0 | R-0 | R-0 |
| DSADR<15:8> | | | | | | | |
| bit 15 | | | | bit 8 | | | |

| | | | | | | | |
|------------|-----|-----|-----|-------|-----|-----|-----|
| R-0 | R-0 | R-0 | R-0 | R-0 | R-0 | R-0 | R-0 |
| DSADR<7:0> | | | | | | | |
| bit 7 | | | | bit 0 | | | |

Legend:

R = Readable bit

W = Writable bit

U = Unimplemented bit, read as '0'

-n = Value at POR

'1' = Bit is set

'0' = Bit is cleared

x = Bit is unknown

bit 15-0 **DSADR<15:0>**: Most Recent DMA RAM Address Accessed by DMA Controller bits

NOTES:

9.0 OSCILLATOR CONFIGURATION

Note 1: This data sheet summarizes the features of the dsPIC33FJ32GS406/606/608/610 and dsPIC33FJ64GS406/606/608/610 families of devices. It is not intended to be a comprehensive reference source. To complement the information in this data sheet, refer to **Section 42. “Oscillator (Part IV)”** (DS70307) in the “*dsPIC33F/PIC24H Family Reference Manual*”, which is available from the Microchip web site (www.microchip.com).

2: Some registers and associated bits described in this section may not be available on all devices. Refer to **Section 4.0 “Memory Organization”** in this data sheet for device-specific register and bit information.

The oscillator system provides:

- External and Internal Oscillator Options as Clock Sources
- An On-Chip Phase-Locked Loop (PLL) to Scale the Internal Operating frequency to the Required System Clock Frequency
- An Internal FRC Oscillator that can also be used with the PLL, thereby allowing Full-Speed Operation without any External Clock Generation Hardware
- Clock Switching Between Various Clock Sources
- Programmable Clock Postscaler for System Power Savings
- A Fail-Safe Clock Monitor (FSCM) that Detects Clock Failure and takes Fail-Safe Measures
- A Clock Control Register (OSCCON)
- Nonvolatile Configuration bits for Main Oscillator Selection
- Auxiliary PLL for ADC and PWM

A simplified diagram of the oscillator system is shown in [Figure 9-1](#).

FIGURE 9-1: OSCILLATOR SYSTEM DIAGRAM



9.1 CPU Clocking System

The dsPIC33FJ32GS406/606/608/610 and dsPIC33FJ64GS406/606/608/610 devices provide six system clock options:

- Fast RC (FRC) Oscillator
- FRC Oscillator with PLL
- Primary (XT, HS, or EC) Oscillator
- Primary Oscillator with PLL
- Low-Power RC (LPRC) Oscillator
- FRC Oscillator with Postscaler
- Secondary (LP) Oscillator

9.1.1 SYSTEM CLOCK SOURCES

The Fast RC (FRC) internal oscillator runs at a nominal frequency of 7.37 MHz. User software can tune the FRC frequency. User software can optionally specify a factor (ranging from 1:2 to 1:256) by which the FRC clock frequency is divided. This factor is selected using the FRCDIV<2:0> (CLKDIV<10:8>) bits.

The primary oscillator can use one of the following as its clock source:

- XT (Crystal): Crystals and ceramic resonators in the range of 3 MHz to 10 MHz. The crystal is connected to the OSC1 and OSC2 pins
- HS (High-Speed Crystal): Crystals in the range of 10 MHz to 50 MHz. The crystal is connected to the OSC1 and OSC2 pins
- EC (External Clock): The external clock signal is directly applied to the OSC1 pin

The secondary (LP) oscillator is designed for low power and uses a 32.768 kHz crystal or ceramic resonator. The LP oscillator uses the SOSCI and SOSCO pins.

The LPRC internal oscillator runs at a nominal frequency of 32.768 kHz. It is also used as a reference clock by the Watchdog Timer (WDT) and Fail-Safe Clock Monitor (FSCM).

The clock signals generated by the FRC and primary oscillators can be optionally applied to an on-chip Phase-Locked Loop (PLL) to provide a wide range of output frequencies for device operation. PLL configuration is described in [Section 9.1.3 “PLL Configuration”](#).

The FRC frequency depends on the FRC accuracy (see [Table 27-20](#)) and the value of the FRC Oscillator Tuning register (see [Register 9-4](#)).

9.1.2 SYSTEM CLOCK SELECTION

The oscillator source used at a device Power-on Reset event is selected using Configuration bit settings. The Oscillator Configuration bit settings are located in the Configuration registers in the program memory. (Refer to [Section 24.1 “Configuration Bits”](#) for further details.) The Initial Oscillator Selection Configuration bits, FNOSC<2:0> (FOSCSEL<2:0>), and the Primary Oscillator Mode Select Configuration bits, POSCMD<1:0> (FOSC<1:0>), select the oscillator source that is used at a Power-on Reset. The FRC primary oscillator is the default (unprogrammed) selection.

The Configuration bits allow users to choose among 12 different clock modes, shown in [Table 9-1](#).

The output of the oscillator (or the output of the PLL if a PLL mode has been selected), Fosc, is divided by 2 to generate the device instruction clock (Fcy) and the peripheral clock time base (Fp). Fcy defines the operating speed of the device and speeds up to 50 MIPS are supported by the device architecture.

Instruction execution speed or device operating frequency, Fcy, is given by [Equation 9-1](#).

EQUATION 9-1: DEVICE OPERATING FREQUENCY

$$F_{CY} = F_{OSC}/2$$

TABLE 9-1: CONFIGURATION BIT VALUES FOR CLOCK SELECTION

| Oscillator Mode | Oscillator Source | POSCMD<1:0> | FNOSC<2:0> | See Notes |
|---|-------------------|-------------|------------|----------------------|
| Fast RC Oscillator with Divide-by-N (FRCDIVN) | Internal | xx | 111 | 1, 2 |
| Fast RC Oscillator with Divide-by-16 (FRCDIV16) | Internal | xx | 110 | 1 |
| Low-Power RC Oscillator (LPRC) | Internal | xx | 101 | 1 |
| Secondary Oscillator (SOSC) | Secondary | xx | 100 | — |
| Primary Oscillator (HS) with PLL (HSPLL) | Primary | 10 | 011 | — |
| Primary Oscillator (XT) with PLL (XTPLL) | Primary | 01 | 011 | — |
| Primary Oscillator (EC) with PLL (ECPLL) | Primary | 00 | 011 | 1 |
| Primary Oscillator (HS) | Primary | 10 | 010 | — |
| Primary Oscillator (XT) | Primary | 01 | 010 | — |
| Primary Oscillator (EC) | Primary | 00 | 010 | 1 |
| Fast RC Oscillator with PLL (FRCPLL) | Internal | xx | 001 | 1 |
| Fast RC Oscillator (FRC) | Internal | xx | 000 | 1 |

Note 1: OSC2 pin function is determined by the OSCIOFNC Configuration bit.

2: This is the default oscillator mode for an unprogrammed (erased) device.

9.1.3 PLL CONFIGURATION

The primary oscillator and internal FRC oscillator can optionally use an on-chip PLL to obtain higher speeds of operation. The PLL provides significant flexibility in selecting the device operating speed. A block diagram of the PLL is shown in [Figure 9-2](#).

The output of the primary oscillator or FRC, denoted as 'FIN', is divided down by a prescale factor (N1) of 2, 3, ... or 33 before being provided to the PLL's Voltage Controlled Oscillator (VCO). The input to the VCO must be selected in the range of 0.8 MHz to 8 MHz. The prescale factor 'N1' is selected using the PLLPRE<4:0> bits (CLKDIV<4:0>).

The PLL Feedback Divisor, selected using the PLLDIV<8:0> bits (PLLFB<8:0>), provides a factor, 'M', by which the input to the VCO is multiplied. This factor must be selected such that the resulting VCO output frequency is in the range of 100 MHz to 200 MHz.

The VCO output is further divided by a postscale factor, 'N2'. This factor is selected using the PLLPOST<1:0> bits (CLKDIV<7:6>). 'N2' can be either 2, 4 or 8, and must be selected such that the PLL output frequency (Fosc) is in the range of 12.5 MHz to 100 MHz, which generates device operating speeds of 6.25-50 MIPS.

For a primary oscillator or FRC oscillator, output 'FIN', the PLL output 'Fosc' is given by [Equation 9-2](#).

EQUATION 9-2: Fosc CALCULATION

$$F_{OSC} = F_{IN} * \left(\frac{M}{N1 * N2} \right)$$

For example, suppose a 10 MHz crystal is being used with the selected oscillator mode of XT with PLL (see [Equation 9-3](#)).

- If PLLPRE<4:0> = 0000, then N1 = 2. This yields a VCO input of 10/2 = 5 MHz, which is within the acceptable range of 0.8-8 MHz.
- If PLLDIV<8:0> = 0x26, then M = 40. This yields a VCO output of 5 x 40 = 200 MHz, which is within the 100-200 MHz ranged needed.
- If PLLPOST<1:0> = 00, then N2 = 2. This provides a Fosc of 200/2 = 100 MHz. The resultant device operating speed is 100/2 = 40 MIPS.

EQUATION 9-3: XT WITH PLL MODE EXAMPLE

$$F_{CY} = \frac{F_{OSC}}{2} = \frac{1}{2} \left(\frac{10000000 * 40}{2 * 2} \right) = 50 \text{ MIPS}$$

FIGURE 9-2: PLL BLOCK DIAGRAM



9.2 Auxiliary Clock Generation

The auxiliary clock generation is used for a peripherals that need to operate at a frequency unrelated to the system clock such as a PWM or ADC.

The primary oscillator and internal FRC oscillator sources can be used with an auxiliary PLL to obtain the auxiliary clock. The auxiliary PLL has a fixed 16x multiplication factor.

The auxiliary clock has the following configuration restrictions:

- For proper PWM operation, auxiliary clock generation must be configured for 120 MHz (see Parameter OS56 in Table 27-18 in Section 27.0 “Electrical Characteristics”). If a slower frequency is desired, the PWM Input Clock Prescaler (Divider) Select bits (PCLKDIV<2:0>) should be used.
- To achieve 1.04 ns PWM resolution, the auxiliary clock must use the 16x auxiliary PLL (APLL). All other clock sources will have a minimum PWM resolution of 8 ns.
- If the primary PLL is used as a source for the auxiliary clock, the primary PLL should be configured up to a maximum operation of 30 MIPS or less.

9.3 Reference Clock Generation

The reference clock output logic provides the user with the ability to output a clock signal based on the system clock or the crystal oscillator on a device pin. The user application can specify a wide range of clock scaling prior to outputting the reference clock.

9.4 Oscillator Control Registers

REGISTER 9-1: OSCCON: OSCILLATOR CONTROL REGISTER⁽¹⁾

| | | | | | | | |
|--------|-----------|-----|-----|-------|--------------------------|-------|-------|
| U-0 | R-y | R-y | R-y | U-0 | R/W-y | R/W-y | R/W-y |
| — | COSC<2:0> | | | — | NOSC<2:0> ⁽²⁾ | | |
| bit 15 | | | | bit 8 | | | |

| | | | | | | | |
|---------|-----|------|-----|-------|-----|-----|-------|
| R/W-0 | U-0 | R-0 | U-0 | R/C-0 | U-0 | U-0 | R/W-0 |
| CLKLOCK | — | LOCK | — | CF | — | — | OSWEN |
| bit 7 | | | | | | | bit 0 |

| | | |
|-------------------|-------------------|--|
| Legend: | C = Clearable bit | y = Value set from Configuration bits on POR |
| R = Readable bit | W = Writable bit | U = Unimplemented bit, read as '0' |
| -n = Value at POR | '1' = Bit is set | '0' = Bit is cleared x = Bit is unknown |

bit 15 **Unimplemented:** Read as '0'

bit 14-12 **COSC<2:0>:** Current Oscillator Selection bits (read-only)

- 111 = Fast RC oscillator (FRC) with divide-by-n
- 110 = Fast RC oscillator (FRC) with divide-by-16
- 101 = Low-Power RC oscillator (LPRC)
- 100 = Secondary oscillator (SOSC)
- 011 = Primary oscillator (XT, HS, EC) with PLL
- 010 = Primary oscillator (XT, HS, EC)
- 001 = Fast RC oscillator (FRC) with PLL
- 000 = Fast RC oscillator (FRC)

bit 11 **Unimplemented:** Read as '0'

bit 10-8 **NOSC<2:0>:** New Oscillator Selection bits⁽²⁾

- 111 = Fast RC oscillator (FRC) with divide-by-n
- 110 = Fast RC oscillator (FRC) with divide-by-16
- 101 = Low-Power RC oscillator (LPRC)
- 100 = Secondary oscillator (SOSC)
- 011 = Primary oscillator (XT, HS, EC) with PLL
- 010 = Primary oscillator (XT, HS, EC)
- 001 = Fast RC oscillator (FRC) with PLL
- 000 = Fast RC oscillator (FRC)

bit 7 **CLKLOCK:** Clock Lock Enable bit

If Clock Switching is Enabled and FSCM is Disabled (FCKSM<1:0> (FOSC<7:6>) = 0b01):

- 1 = Clock switching is disabled, system clock source is locked
- 0 = Clock switching is enabled, system clock source can be modified by clock switching

bit 6 **Unimplemented:** Read as '0'

bit 5 **LOCK:** PLL Lock Status bit (read-only)

- 1 = Indicates that PLL is in lock or PLL start-up timer is satisfied
- 0 = Indicates that PLL is out of lock, start-up timer is in progress or PLL is disabled

bit 4 **Unimplemented:** Read as '0'

Note 1: Writes to this register require an unlock sequence. Refer to **Section 42. "Oscillator (Part IV)"** (DS70307) in the *"dsPIC33F/PIC24H Family Reference Manual"* for details.

2: Direct clock switches between any primary oscillator mode with PLL and FRCPLL mode are not permitted. This applies to clock switches in either direction. In these instances, the application must switch to FRC mode as a transition clock source between the two PLL modes.

REGISTER 9-1: OSCCON: OSCILLATOR CONTROL REGISTER⁽¹⁾ (CONTINUED)

- bit 3 **CF:** Clock Fail Detect bit (read/clear by application)
 1 = FSCM has detected clock failure
 0 = FSCM has not detected clock failure
- bit 2-1 **Unimplemented:** Read as '0'
- bit 0 **OSWEN:** Oscillator Switch Enable bit
 1 = Requests oscillator switch to selection specified by NOSC<2:0> bits
 0 = Oscillator switch is complete

- Note 1:** Writes to this register require an unlock sequence. Refer to **Section 42. "Oscillator (Part IV)"** (DS70307) in the *"dsPIC33F/PIC24H Family Reference Manual"* for details.
- 2:** Direct clock switches between any primary oscillator mode with PLL and FRCPLL mode are not permitted. This applies to clock switches in either direction. In these instances, the application must switch to FRC mode as a transition clock source between the two PLL modes.

dsPIC33FJ32GS406/606/608/610 and dsPIC33FJ64GS406/606/608/610

REGISTER 9-2: CLKDIV: CLOCK DIVISOR REGISTER

| | | | | | | | |
|--------|-----------|-------|----------------------|-------|-------------|-------|-------|
| R/W-0 | R/W-0 | R/W-1 | R/W-1 | R/W-0 | R/W-0 | R/W-0 | R/W-0 |
| ROI | DOZE<2:0> | | DOZEN ⁽¹⁾ | | FRCDIV<2:0> | | |
| bit 15 | | | | | | | bit 8 |

| | | | | | | | |
|--------------|-------|-----|-------------|-------|-------|-------|-------|
| R/W-0 | R/W-1 | U-0 | R/W-0 | R/W-0 | R/W-0 | R/W-0 | R/W-0 |
| PLLPOST<1:0> | | — | PLLPRE<4:0> | | | | |
| bit 7 | | | | | | | bit 0 |

Legend:

R = Readable bit W = Writable bit U = Unimplemented bit, read as '0'
 -n = Value at POR '1' = Bit is set '0' = Bit is cleared x = Bit is unknown

- bit 15 **ROI:** Recover on Interrupt bit
 1 = Interrupts will clear the DOZEN bit and the processor clock/peripheral clock ratio is set to 1:1
 0 = Interrupts have no effect on the DOZEN bit
- bit 14-12 **DOZE<2:0>:** Processor Clock Reduction Select bits
 111 = Fcy/128
 110 = Fcy/64
 101 = Fcy/32
 100 = Fcy/16
 011 = Fcy/8 (default)
 010 = Fcy/4
 001 = Fcy/2
 000 = Fcy/1
- bit 11 **DOZEN:** Doze Mode Enable bit⁽¹⁾
 1 = DOZE<2:0> field specifies the ratio between the peripheral clocks and the processor clocks
 0 = Processor clock/peripheral clock ratio forced to 1:1
- bit 10-8 **FRCDIV<2:0>:** Internal Fast RC Oscillator Postscaler bits
 111 = FRC divide-by-256
 110 = FRC divide-by-64
 101 = FRC divide-by-32
 100 = FRC divide-by-16
 011 = FRC divide-by-8
 010 = FRC divide-by-4
 001 = FRC divide-by-2
 000 = FRC divide-by-1 (default)
- bit 7-6 **PLLPOST<1:0>:** PLL VCO Output Divider Select bits (also denoted as 'N2', PLL postscaler)
 11 = Output/8
 10 = Reserved
 01 = Output/4 (default)
 00 = Output/2
- bit 5 **Unimplemented:** Read as '0'
- bit 4-0 **PLLPRE<4:0>:** PLL Phase Detector Input Divider bits (also denoted as 'N1', PLL prescaler)
 00000 = Input/2 (default)
 00001 = Input/3
 •
 •
 •
 11111 = Input/33

Note 1: This bit is cleared when the ROI bit is set and an interrupt occurs.

dsPIC33FJ32GS406/606/608/610 and dsPIC33FJ64GS406/606/608/610

REGISTER 9-3: PLLFBD: PLL FEEDBACK DIVISOR REGISTER

| | | | | | | | |
|--------|-----|-----|-----|-----|-----|-----|---------|
| U-0 | U-0 | U-0 | U-0 | U-0 | U-0 | U-0 | R/W-0 |
| — | — | — | — | — | — | — | PLLDIV8 |
| bit 15 | | | | | | | bit 8 |

| | | | | | | | |
|-------------|-------|-------|-------|-------|-------|-------|-------|
| R/W-0 | R/W-0 | R/W-1 | R/W-1 | R/W-0 | R/W-0 | R/W-0 | R/W-0 |
| PLLDIV<7:0> | | | | | | | |
| bit 7 | | | | | | | bit 0 |

Legend:

R = Readable bit W = Writable bit U = Unimplemented bit, read as '0'
 -n = Value at POR '1' = Bit is set '0' = Bit is cleared x = Bit is unknown

bit 15-9 **Unimplemented:** Read as '0'

bit 8-0 **PLLDIV<8:0>:** PLL Feedback Divisor bits (also denoted as 'M', PLL multiplier)

000000000 = 2

000000001 = 3

000000010 = 4

•

•

•

000110000 = 50 (default)

•

•

•

111111111 = 513

dsPIC33FJ32GS406/606/608/610 and dsPIC33FJ64GS406/606/608/610

REGISTER 9-4: OSCTUN: OSCILLATOR TUNING REGISTER

| | | | | | | | |
|--------|-----|-----|-----|-----|-----|-----|-------|
| U-0 | U-0 | U-0 | U-0 | U-0 | U-0 | U-0 | U-0 |
| — | — | — | — | — | — | — | — |
| bit 15 | | | | | | | bit 8 |

| | | | | | | | |
|-------|-----|-------------------------|-------|-------|-------|-------|-------|
| U-0 | U-0 | R/W-0 | R/W-0 | R/W-0 | R/W-0 | R/W-0 | R/W-0 |
| — | — | TUN<5:0> ⁽¹⁾ | | | | | |
| bit 7 | | | | | | | bit 0 |

Legend:

R = Readable bit

W = Writable bit

U = Unimplemented bit, read as '0'

-n = Value at POR

'1' = Bit is set

'0' = Bit is cleared

x = Bit is unknown

bit 15-6 **Unimplemented:** Read as '0'

bit 5-0 **TUN<5:0>:** FRC Oscillator Tuning bits⁽¹⁾

011111 = Center frequency + 11.625% (8.23 MHz)

011110 = Center frequency + 11.25% (8.20 MHz)

•

•

•

000001 = Center frequency + 0.375% (7.40 MHz)

000000 = Center frequency (7.37 MHz nominal)

111111 = Center frequency – 0.375% (7.345 MHz)

•

•

•

100001 = Center frequency – 11.625% (6.52 MHz)

100000 = Center frequency – 12% (6.49 MHz)

Note 1: OSCTUN functionality has been provided to help customers compensate for temperature effects on the FRC frequency over a wide range of temperatures. The tuning step-size is an approximation and is neither characterized nor tested.

dsPIC33FJ32GS406/606/608/610 and dsPIC33FJ64GS406/606/608/610

REGISTER 9-5: ACLKCON: AUXILIARY CLOCK DIVISOR CONTROL REGISTER

| | | | | | | | |
|--------|--------|---------|-----|-----|---------------|-------|-------|
| R/W-0 | R-0 | R/W-1 | U-0 | U-0 | R/W-1 | R/W-1 | R/W-1 |
| ENAPLL | APLLCK | SELACLK | — | — | APSTSCLR<2:0> | | |
| bit 15 | | | | | | bit 0 | |

| | | | | | | | |
|---------|--------|-----|-----|-----|-----|-----|-----|
| R/W-0 | R/W-0 | U-0 | U-0 | U-0 | U-0 | U-0 | U-0 |
| ASRCSEL | FRCSEL | — | — | — | — | — | — |
| bit 7 | | | | | | | |

Legend:

R = Readable bit W = Writable bit U = Unimplemented bit, read as '0'
 -n = Value at POR '1' = Bit is set '0' = Bit is cleared x = Bit is unknown

- bit 15 **ENAPLL:** Auxiliary PLL Enable bit
 1 = APLL is enabled
 0 = APLL is disabled
- bit 14 **APLLCK:** APLL Locked Status bit (read-only)
 1 = Indicates that auxiliary PLL is in lock
 0 = Indicates that auxiliary PLL is not in lock
- bit 13 **SELACLK:** Select Auxiliary Clock Source for Auxiliary Clock Divider bit
 1 = Auxiliary oscillators provide the source clock for the auxiliary clock divider
 0 = Primary PLL (Fvco) provides the source clock for the auxiliary clock divider
- bit 12-11 **Unimplemented:** Read as '0'
- bit 10-8 **APSTSCLR<2:0>:** Auxiliary Clock Output Divider bits
 111 = Divided by 1
 110 = Divided by 2
 101 = Divided by 4
 100 = Divided by 8
 011 = Divided by 16
 010 = Divided by 32
 001 = Divided by 64
 000 = Divided by 256
- bit 7 **ASRCSEL:** Select Reference Clock Source for Auxiliary Clock bit
 1 = Primary oscillator is the clock source
 0 = No clock input is selected
- bit 6 **FRCSEL:** Select Reference Clock Source for Auxiliary PLL bit
 1 = Selects FRC clock for auxiliary PLL
 0 = Input clock source is determined by ASRCSEL bit setting
- bit 5-0 **Unimplemented:** Read as '0'

dsPIC33FJ32GS406/606/608/610 and dsPIC33FJ64GS406/606/608/610

REGISTER 9-6: REFOCON: REFERENCE OSCILLATOR CONTROL REGISTER

| | | | | | | | |
|--------|-----|--------|-------|---------------------------|-------|-------|-------|
| R/W-0 | U-0 | R/W-0 | R/W-0 | R/W-0 | R/W-0 | R/W-0 | R/W-0 |
| ROON | — | ROSSLP | ROSEL | RODIV<3:0> ⁽¹⁾ | | | |
| bit 15 | | | | | | | bit 8 |

| | | | | | | | |
|-------|-----|-----|-----|-----|-----|-----|-------|
| U-0 | U-0 | U-0 | U-0 | U-0 | U-0 | U-0 | U-0 |
| — | — | — | — | — | — | — | — |
| bit 7 | | | | | | | bit 0 |

Legend:

R = Readable bit W = Writable bit U = Unimplemented bit, read as '0'
 -n = Value at POR '1' = Bit is set '0' = Bit is cleared x = Bit is unknown

bit 15 **ROON:** Reference Oscillator Output Enable bit
 1 = Reference oscillator output is enabled on REFCLK0 pin
 0 = Reference oscillator output is disabled

bit 14 **Unimplemented:** Read as '0'

bit 13 **ROSSLP:** Reference Oscillator Run in Sleep bit
 1 = Reference oscillator output continues to run in Sleep
 0 = Reference oscillator output is disabled in Sleep

bit 12 **ROSEL:** Reference Oscillator Source Select bit
 1 = Oscillator crystal used as the reference clock
 0 = System clock used as the reference clock

bit 11-8 **RODIV<3:0>:** Reference Oscillator Divider bits⁽¹⁾
 1111 = Reference clock divided by 32,768
 1110 = Reference clock divided by 16,384
 1101 = Reference clock divided by 8,192
 1100 = Reference clock divided by 4,096
 1011 = Reference clock divided by 2,048
 1010 = Reference clock divided by 1,024
 1001 = Reference clock divided by 512
 1000 = Reference clock divided by 256
 0111 = Reference clock divided by 128
 0110 = Reference clock divided by 64
 0101 = Reference clock divided by 32
 0100 = Reference clock divided by 16
 0011 = Reference clock divided by 8
 0010 = Reference clock divided by 4
 0001 = Reference clock divided by 2
 0000 = Reference clock

bit 7-0 **Unimplemented:** Read as '0'

Note 1: The reference oscillator output must be disabled (ROON = 0) before writing to these bits.

9.5 Clock Switching Operation

Applications are free to switch among any of the four clock sources (primary, LP, FRC and LPRC) under software control at any time. To limit the possible side effects of this flexibility, dsPIC33FJ32GS406/606/608/610 and dsPIC33FJ64GS406/606/608/610 devices have a safeguard lock built into the switch process.

Note: Primary oscillator mode has three different submodes (XT, HS and EC), which are determined by the POSCMD<1:0> Configuration bits. While an application can switch to and from primary oscillator mode in software, it cannot switch among the different primary submodes without reprogramming the device.

9.5.1 ENABLING CLOCK SWITCHING

To enable clock switching, the FCKSM1 Configuration bit in the Configuration register must be programmed to '0'. (Refer to [Section 24.1 "Configuration Bits"](#) for further details.) If the FCKSM1 Configuration bit is unprogrammed ('1'), the clock switching function and Fail-Safe Clock Monitor function are disabled. This is the default setting.

The NOSC control bits (OSCCON<10:8>) do not control the clock selection when clock switching is disabled. However, the COSC bits (OSCCON<14:12>) reflect the clock source selected by the FNOSC Configuration bits.

The OSWEN control bit (OSCCON<0>) has no effect when clock switching is disabled. It is held at '0' at all times.

9.5.2 OSCILLATOR SWITCHING SEQUENCE

To perform a clock switch, the following basic sequence is required:

1. If desired, read the COSCx bits (OSCCON<14:12>) to determine the current oscillator source.
2. Perform the unlock sequence to allow a write to the OSCCON register high byte.
3. Write the appropriate value to the NOSCx control bits (OSCCON<10:8>) for the new oscillator source.
4. Perform the unlock sequence to allow a write to the OSCCON register low byte.
5. Set the OSWEN bit (OSCCON<0>) to initiate the oscillator switch.

Once the basic sequence is completed, the system clock hardware responds automatically as follows:

1. The clock switching hardware compares the COSCx status bits with the new value of the NOSCx control bits. If they are the same, the clock switch is a redundant operation. In this case, the OSWEN bit is cleared automatically and the clock switch is aborted.

2. If a valid clock switch has been initiated, the LOCK (OSCCON<5>) and the CF (OSCCON<3>) status bits are cleared.
3. The new oscillator is turned on by the hardware if it is not currently running. If a crystal oscillator must be turned on, the hardware waits until the Oscillator Start-up Timer (OST) expires. If the new source is using the PLL, the hardware waits until a PLL lock is detected (LOCK = 1).
4. The hardware waits for 10 clock cycles from the new clock source and then performs the clock switch.
5. The hardware clears the OSWEN bit to indicate a successful clock transition. In addition, the NOSCx bit values are transferred to the COSCx status bits.
6. The old clock source is turned off at this time, with the exception of LPRC (if WDT or FSCM are enabled) or LP (if LPOSCEN remains set).

Note 1: The processor continues to execute code throughout the clock switching sequence. Timing-sensitive code should not be executed during this time.

2: Direct clock switches between any primary oscillator mode with PLL and FRCPLL mode are not permitted. This applies to clock switches in either direction. In these instances, the application must switch to FRC mode as a transition clock source between the two PLL modes.

3: Refer to [Section 42. "Oscillator \(Part IV\)"](#) (DS70307) in the *"dsPIC33F/PIC24H Family Reference Manual"* for details.

9.6 Fail-Safe Clock Monitor (FSCM)

The Fail-Safe Clock Monitor (FSCM) allows the device to continue to operate even in the event of an oscillator failure. The FSCM function is enabled by programming. If the FSCM function is enabled, the LPRC internal oscillator runs at all times (except during Sleep mode) and is not subject to control by the Watchdog Timer.

In the event of an oscillator failure, the FSCM generates a clock failure trap event and switches the system clock over to the FRC oscillator. Then, the application program can either attempt to restart the oscillator or execute a controlled shutdown. The trap can be treated as a Warm Reset by simply loading the Reset address into the oscillator fail trap vector.

If the PLL multiplier is used to scale the system clock, the internal FRC is also multiplied by the same factor on clock failure. Essentially, the device switches to FRC with PLL on a clock failure.

NOTES:

10.0 POWER-SAVING FEATURES

Note 1: This data sheet summarizes the features of the dsPIC33FJ32GS406/606/608/610 and dsPIC33FJ64GS406/606/608/610 families of devices. It is not intended to be a comprehensive reference source. To complement the information in this data sheet, refer to **Section 9. “Watchdog Timer and Power-Saving Modes”** (DS70196) in the “dsPIC33F/PIC24H Family Reference Manual”, which is available from the Microchip web site (www.microchip.com).

2: Some registers and associated bits described in this section may not be available on all devices. Refer to **Section 4.0 “Memory Organization”** in this data sheet for device-specific register and bit information.

The dsPIC33FJ32GS406/606/608/610 and dsPIC33FJ64GS406/606/608/610 devices provide the ability to manage power consumption by selectively managing clocking to the CPU and the peripherals. In general, a lower clock frequency and a reduction in the number of circuits being clocked constitutes lower consumed power. Devices can manage power consumption in four different ways:

- Clock Frequency
- Instruction-Based Sleep and Idle modes
- Software Controlled Doze mode
- Selective Peripheral Control in Software

Combinations of these methods can be used to selectively tailor an application’s power consumption while still maintaining critical application features, such as timing-sensitive communications.

10.1 Clock Frequency and Clock Switching

The devices allow a wide range of clock frequencies to be selected under application control. If the system clock configuration is not locked, users can choose low-power or high-precision oscillators by simply changing the NOSC_x bits (OSCCON<10:8>). The process of changing a system clock during operation, as well as limitations to the process, are discussed in more detail in **Section 9.0 “Oscillator Configuration”**.

EXAMPLE 10-1: PWRSAV INSTRUCTION SYNTAX

```
PWRSAV #SLEEP_MODE      ; Put the device into SLEEP mode
PWRSAV #IDLE_MODE       ; Put the device into IDLE mode
```

10.2 Instruction-Based Power-Saving Modes

The devices have two special power-saving modes that are entered through the execution of a special PWRSAV instruction. Sleep mode stops clock operation and halts all code execution. Idle mode halts the CPU and code execution, but allows peripheral modules to continue operation. The assembler syntax of the PWRSAV instruction is shown in **Example 10-1**.

Note: SLEEP_MODE and IDLE_MODE are constants defined in the assembler include file for the selected device.

Sleep and Idle modes can be exited as a result of an enabled interrupt, WDT time-out or a device Reset. When the device exits these modes, it is said to wake-up.

10.2.1 SLEEP MODE

The following occurs in Sleep mode:

- The system clock source is shut down. If an on-chip oscillator is used, it is turned off.
- The device current consumption is reduced to a minimum, provided that no I/O pin is sourcing current.
- The Fail-Safe Clock Monitor does not operate, since the system clock source is disabled.
- The LPRC clock continues to run in Sleep mode if the WDT is enabled.
- The WDT, if enabled, is automatically cleared prior to entering Sleep mode.
- Some device features or peripherals may continue to operate. This includes the items such as the input change notification on the I/O ports or peripherals that use an external clock input.
- Any peripheral that requires the system clock source for its operation is disabled.

The device will wake-up from Sleep mode on any of these events:

- Any interrupt source that is individually enabled
- Any form of device Reset
- A WDT time-out

On wake-up from Sleep mode, the processor restarts with the same clock source that was active when Sleep mode was entered.

10.2.2 IDLE MODE

The following occur in Idle mode:

- The CPU stops executing instructions.
- The WDT is automatically cleared.
- The system clock source remains active. By default, all peripheral modules continue to operate normally from the system clock source, but can also be selectively disabled (see [Section 10.5 “Peripheral Module Disable”](#)).
- If the WDT or FSCM is enabled, the LPRC also remains active.

The device will wake-up from Idle mode on any of these events:

- Any interrupt that is individually enabled
- Any device Reset
- A WDT time-out

On wake-up from Idle mode, the clock is reapplied to the CPU and instruction execution will begin (2-4 clock cycles later), starting with the instruction following the `PWRSVAV` instruction, or the first instruction in the ISR.

10.2.3 INTERRUPTS COINCIDENT WITH POWER SAVE INSTRUCTIONS

Any interrupt that coincides with the execution of a `PWRSVAV` instruction is held off until entry into Sleep or Idle mode has completed. The device then wakes up from Sleep or Idle mode.

10.3 Doze Mode

The preferred strategies for reducing power consumption are changing clock speed and invoking one of the power-saving modes. In some circumstances, this may not be practical. For example, it may be necessary for an application to maintain uninterrupted synchronous communication, even while it is doing nothing else. Reducing system clock speed can introduce communication errors, while using a power-saving mode can stop communications completely.

Doze mode is a simple and effective alternative method to reduce power consumption while the device is still executing code. In this mode, the system clock continues to operate from the same source and at the same speed. Peripheral modules continue to be clocked at the same speed, while the CPU clock speed is reduced. Synchronization between the two clock domains is maintained, allowing the peripherals to access the SFRs while the CPU executes code at a slower rate.

Doze mode is enabled by setting the DOZEN bit (`CLKDIV<11>`). The ratio between peripheral and core clock speed is determined by the `DOZE<2:0>` bits (`CLKDIV<14:12>`). There are eight possible configurations, from 1:1 to 1:128, with 1:1 being the default setting.

Programs can use Doze mode to selectively reduce power consumption in event-driven applications. This allows clock-sensitive functions, such as synchronous communications, to continue without interruption while the CPU idles, waiting for something to invoke an interrupt routine. An automatic return to full-speed CPU operation on interrupts can be enabled by setting the ROI bit (`CLKDIV<15>`). By default, interrupt events have no effect on Doze mode operation.

For example, suppose the device is operating at 20 MIPS and the CAN module has been configured for 500 kbps based on this device operating speed. If the device is placed in Doze mode with a clock frequency ratio of 1:4, the CAN module continues to communicate at the required bit rate of 500 kbps, but the CPU now starts executing instructions at a frequency of 5 MIPS.

10.4 PWM Power-Saving Features

Typically, many applications need either a high-resolution duty cycle or phase offset (for fixed frequency operation) or a high-resolution PWM period for variable frequency modes of operation (such as Resonant mode). Very few applications require both high-resolution modes simultaneously.

The HRPDIS and the HRDDIS bits in the AUXCONx registers permit the user to disable the circuitry associated with the high-resolution duty cycle and PWM period to reduce the operating current of the device.

If the HRDDIS bit is set, the circuitry associated with the high-resolution duty cycle, phase offset, and dead time for the respective PWM generator is disabled. If the HRPDIS bit is set, the circuitry associated with the high-resolution PWM period for the respective PWM generator is disabled.

When the HRPDIS bit is set, the smallest unit of measure for the PWM period is 8.32 ns.

If the HRDDIS bit is set, the smallest unit of measure for the PWM duty cycle, phase offset and dead time is 8.32 ns.

10.5 Peripheral Module Disable

The Peripheral Module Disable (PMD) registers provide a method to disable a peripheral module by stopping all clock sources supplied to that module. When a peripheral is disabled using the appropriate PMD control bit, the peripheral is in a minimum power consumption state. The control and status registers associated with the peripheral are also disabled, so writes to those registers will have no effect and read values will be invalid.

A peripheral module is enabled only if both the associated bit in the PMD register is cleared and the peripheral is supported by the specific dsPIC® DSC variant. If the peripheral is present in the device, it is enabled in the PMD register by default.

| |
|---|
| <p>Note: If a PMD bit is set, the corresponding module is disabled after a delay of one instruction cycle. Similarly, if a PMD bit is cleared, the corresponding module is enabled after a delay of one instruction cycle (assuming the module control registers are already configured to enable module operation).</p> |
|---|

dsPIC33FJ32GS406/606/608/610 and dsPIC33FJ64GS406/606/608/610

REGISTER 10-1: PMD1: PERIPHERAL MODULE DISABLE CONTROL REGISTER 1

| | | | | | | | |
|--------|-------|-------|-------|-------|--------|----------------------|-------|
| R/W-0 | R/W-0 | R/W-0 | R/W-0 | R/W-0 | R/W-0 | R/W-0 | U-0 |
| T5MD | T4MD | T3MD | T2MD | T1MD | QE11MD | PWMMD ⁽¹⁾ | — |
| bit 15 | | | | | | | bit 8 |

| | | | | | | | |
|--------|-------|-------|--------|--------|-----|-------|-------|
| R/W-0 | R/W-0 | R/W-0 | R/W-0 | R/W-0 | U-0 | R/W-0 | R/W-0 |
| I2C1MD | U2MD | U1MD | SPI2MD | SPI1MD | — | C1MD | ADCMD |
| bit 7 | | | | | | | bit 0 |

Legend:

R = Readable bit

W = Writable bit

U = Unimplemented bit, read as '0'

-n = Value at POR

'1' = Bit is set

'0' = Bit is cleared

x = Bit is unknown

- bit 15 **T5MD:** Timer5 Module Disable bit
 1 = Timer5 module is disabled
 0 = Timer5 module is enabled
- bit 14 **T4MD:** Timer4 Module Disable bit
 1 = Timer4 module is disabled
 0 = Timer4 module is enabled
- bit 13 **T3MD:** Timer3 Module Disable bit
 1 = Timer3 module is disabled
 0 = Timer3 module is enabled
- bit 12 **T2MD:** Timer2 Module Disable bit
 1 = Timer2 module is disabled
 0 = Timer2 module is enabled
- bit 11 **T1MD:** Timer1 Module Disable bit
 1 = Timer1 module is disabled
 0 = Timer1 module is enabled
- bit 10 **QE11MD:** QE11 Module Disable bit
 1 = QE11 module is disabled
 0 = QE11 module is enabled
- bit 9 **PWMMD:** PWM Module Disable bit⁽¹⁾
 1 = PWM module is disabled
 0 = PWM module is enabled
- bit 8 **Unimplemented:** Read as '0'
- bit 7 **I2C1MD:** I2C1 Module Disable bit
 1 = I2C1 module is disabled
 0 = I2C1 module is enabled
- bit 6 **U2MD:** UART2 Module Disable bit
 1 = UART2 module is disabled
 0 = UART2 module is enabled
- bit 5 **U1MD:** UART1 Module Disable bit
 1 = UART1 module is disabled
 0 = UART1 module is enabled
- bit 4 **SPI2MD:** SPI2 Module Disable bit
 1 = SPI2 module is disabled
 0 = SPI2 module is enabled

Note 1: Once the PWM module is re-enabled (PWMMD is set to '1' and then set to '0'), all PWM registers must be re-initialized.

REGISTER 10-1: PMD1: PERIPHERAL MODULE DISABLE CONTROL REGISTER 1 (CONTINUED)

| | |
|-------|--|
| bit 3 | SPI1MD: SPI1 Module Disable bit 1 = SPI1 module is disabled 0 = SPI1 module is enabled |
| bit 2 | Unimplemented: Read as '0' |
| bit 1 | C1MD: ECAN1 Module Disable bit 1 = ECAN1 module is disabled 0 = ECAN1 module is enabled |
| bit 0 | ADCMD: ADC Module Disable bit 1 = ADC module is disabled 0 = ADC module is enabled |

Note 1: Once the PWM module is re-enabled (PWMMMD is set to '1' and then set to '0'), all PWM registers must be re-initialized.

dsPIC33FJ32GS406/606/608/610 and dsPIC33FJ64GS406/606/608/610

REGISTER 10-2: PMD2: PERIPHERAL MODULE DISABLE CONTROL REGISTER 2

| | | | | | | | |
|--------|-----|-----|-----|-------|-------|-------|-------|
| U-0 | U-0 | U-0 | U-0 | R/W-0 | R/W-0 | R/W-0 | R/W-0 |
| — | — | — | — | IC4MD | IC3MD | IC2MD | IC1MD |
| bit 15 | | | | | | | bit 8 |

| | | | | | | | |
|-------|-----|-----|-----|-------|-------|-------|-------|
| U-0 | U-0 | U-0 | U-0 | R/W-0 | R/W-0 | R/W-0 | R/W-0 |
| — | — | — | — | OC4MD | OC3MD | OC2MD | OC1MD |
| bit 7 | | | | | | | bit 0 |

Legend:

R = Readable bit

W = Writable bit

U = Unimplemented bit, read as '0'

-n = Value at POR

'1' = Bit is set

'0' = Bit is cleared

x = Bit is unknown

- bit 15-12 **Unimplemented:** Read as '0'
- bit 11 **IC4MD:** Input Capture 4 Module Disable bit
 1 = Input Capture 4 module is disabled
 0 = Input Capture 4 module is enabled
- bit 19 **IC3MD:** Input Capture 3 Module Disable bit
 1 = Input Capture 3 module is disabled
 0 = Input Capture 3 module is enabled
- bit 9 **IC2MD:** Input Capture 2 Module Disable bit
 1 = Input Capture 2 module is disabled
 0 = Input Capture 2 module is enabled
- bit 8 **IC1MD:** Input Capture 1 Module Disable bit
 1 = Input Capture 1 module is disabled
 0 = Input Capture 1 module is enabled
- bit 7-4 **Unimplemented:** Read as '0'
- bit 3 **OC4MD:** Output Compare 4 Module Disable bit
 1 = Output Compare 4 module is disabled
 0 = Output Compare 4 module is enabled
- bit 2 **OC3MD:** Output Compare 3 Module Disable bit
 1 = Output Compare 3 module is disabled
 0 = Output Compare 3 module is enabled
- bit 1 **OC2MD:** Output Compare 2 Module Disable bit
 1 = Output Compare 2 module is disabled
 0 = Output Compare 2 module is enabled
- bit 0 **OC1MD:** Output Compare 1 Module Disable bit
 1 = Output Compare 1 module is disabled
 0 = Output Compare 1 module is enabled

dsPIC33FJ32GS406/606/608/610 and dsPIC33FJ64GS406/606/608/610

REGISTER 10-3: PMD3: PERIPHERAL MODULE DISABLE CONTROL REGISTER 3

| | | | | | | | |
|--------|-----|--------|-----|-----|-------|--------|-----|
| U-0 | U-0 | U-0 | U-0 | U-0 | R/W-0 | U-0 | U-0 |
| — | — | — | — | — | CMPMD | — | — |
| bit 15 | | | | | | bit 8 | |
| U-0 | U-0 | R/W-0 | U-0 | U-0 | U-0 | R/W-0 | U-0 |
| — | — | QE12MD | — | — | — | I2C2MD | — |
| bit 7 | | | | | | bit 0 | |

Legend:

R = Readable bit W = Writable bit U = Unimplemented bit, read as '0'
 -n = Value at POR '1' = Bit is set '0' = Bit is cleared x = Bit is unknown

- bit 15-11 **Unimplemented:** Read as '0'
- bit 10 **CMPMD:** Analog Comparator Module Disable bit
 1 = Analog comparator module is disabled
 0 = Analog comparator module is enabled
- bit 9-6 **Unimplemented:** Read as '0'
- bit 5 **QE12MD:** QE12 Module Disable bit
 1 = QE12 module is disabled
 0 = QE12 module is enabled
- bit 4-2 **Unimplemented:** Read as '0'
- bit 1 **I2C2MD:** I2C2 Module Disable bit
 1 = I2C2 module is disabled
 0 = I2C2 module is enabled
- bit 0 **Unimplemented:** Read as '0'

REGISTER 10-4: PMD4: PERIPHERAL MODULE DISABLE CONTROL REGISTER 4

| | | | | | | | |
|--------|-----|-----|-----|--------|-----|-------|-----|
| U-0 | U-0 | U-0 | U-0 | U-0 | U-0 | U-0 | U-0 |
| — | — | — | — | — | — | — | — |
| bit 15 | | | | | | bit 8 | |
| U-0 | U-0 | U-0 | U-0 | R/W-0 | U-0 | U-0 | U-0 |
| — | — | — | — | REFOMD | — | — | — |
| bit 7 | | | | | | bit 0 | |

Legend:

R = Readable bit W = Writable bit U = Unimplemented bit, read as '0'
 -n = Value at POR '1' = Bit is set '0' = Bit is cleared x = Bit is unknown

- bit 15-4 **Unimplemented:** Read as '0'
- bit 3 **REFOMD:** Reference Clock Generator Module Disable bit
 1 = Reference clock generator module is disabled
 0 = Reference clock generator module is enabled
- bit 2-0 **Unimplemented:** Read as '0'

dsPIC33FJ32GS406/606/608/610 and dsPIC33FJ64GS406/606/608/610

REGISTER 10-5: PMD6: PERIPHERAL MODULE DISABLE CONTROL REGISTER 6

| | | | | | | | |
|--------|--------|--------|--------|--------|--------|--------|--------|
| R/W-0 | R/W-0 | R/W-0 | R/W-0 | R/W-0 | R/W-0 | R/W-0 | R/W-0 |
| PWM8MD | PWM7MD | PWM6MD | PWM5MD | PWM4MD | PWM3MD | PWM2MD | PWM1MD |
| bit 15 | | | | | | | bit 8 |

| | | | | | | | |
|-------|-----|-----|-----|-----|-----|-----|-------|
| U-0 | U-0 | U-0 | U-0 | U-0 | U-0 | U-0 | U-0 |
| — | — | — | — | — | — | — | — |
| bit 7 | | | | | | | bit 0 |

Legend:

| | | |
|-------------------|------------------|--|
| R = Readable bit | W = Writable bit | U = Unimplemented bit, read as '0' |
| -n = Value at POR | '1' = Bit is set | '0' = Bit is cleared x = Bit is unknown |

- bit 15 **PWM8MD:** PWM Generator 8 Module Disable bit
1 = PWM Generator 8 module is disabled
0 = PWM Generator 8 module is enabled
- bit 14 **PWM7MD:** PWM Generator 7 Module Disable bit
1 = PWM Generator 7 module is disabled
0 = PWM Generator 7 module is enabled
- bit 13 **PWM6MD:** PWM Generator 6 Module Disable bit
1 = PWM Generator 6 module is disabled
0 = PWM Generator 6 module is enabled
- bit 12 **PWM5MD:** PWM Generator 5 Module Disable bit
1 = PWM Generator 5 module is disabled
0 = PWM Generator 5 module is enabled
- bit 11 **PWM4MD:** PWM Generator 4 Module Disable bit
1 = PWM Generator 4 module is disabled
0 = PWM Generator 4 module is enabled
- bit 10 **PWM3MD:** PWM Generator 3 Module Disable bit
1 = PWM Generator 3 module is disabled
0 = PWM Generator 3 module is enabled
- bit 9 **PWM2MD:** PWM Generator 2 Module Disable bit
1 = PWM Generator 2 module is disabled
0 = PWM Generator 2 module is enabled
- bit 8 **PWM1MD:** PWM Generator 1 Module Disable bit
1 = PWM Generator 1 module is disabled
0 = PWM Generator 1 module is enabled
- bit 7-0 **Unimplemented:** Read as '0'

dsPIC33FJ32GS406/606/608/610 and dsPIC33FJ64GS406/606/608/610

REGISTER 10-6: PMD7: PERIPHERAL MODULE DISABLE CONTROL REGISTER 7

| | | | | | | | |
|--------|-----|-----|-----|--------|--------|--------|--------|
| U-0 | U-0 | U-0 | U-0 | R/W-0 | R/W-0 | R/W-0 | R/W-0 |
| — | — | — | — | CMP4MD | CMP3MD | CMP2MD | CMP1MD |
| bit 15 | | | | bit 8 | | | |

| | | | | | | | |
|-------|-----|-----|-----|-----|-----|-----|--------|
| U-0 | U-0 | U-0 | U-0 | U-0 | U-0 | U-0 | R/W-0 |
| — | — | — | — | — | — | — | PWM9MD |
| bit 7 | | | | | | | bit 0 |

Legend:

R = Readable bit W = Writable bit U = Unimplemented bit, read as '0'
 -n = Value at POR '1' = Bit is set '0' = Bit is cleared x = Bit is unknown

- bit 15-12 **Unimplemented:** Read as '0'
- bit 11 **CMP4MD:** Analog Comparator 4 Module Disable bit
 1 = Analog Comparator 4 module is disabled
 0 = Analog Comparator 4 module is enabled
- bit 10 **CMP3MD:** Analog Comparator 3 Module Disable bit
 1 = Analog Comparator 3 module is disabled
 0 = Analog Comparator 3 module is enabled
- bit 9 **CMP2MD:** Analog Comparator 2 Module Disable bit
 1 = Analog Comparator 2 module is disabled
 0 = Analog Comparator 2 module is enabled
- bit 8 **CMP1MD:** Analog Comparator 1 Module Disable bit
 1 = Analog Comparator 1 module is disabled
 0 = Analog Comparator 1 module is enabled
- bit 7-1 **Unimplemented:** Read as '0'
- bit 0 **PWM9MD:** PWM Generator 9 Module Disable bit
 1 = PWM Generator 9 module is disabled
 0 = PWM Generator 9 module is enabled

NOTES:

11.0 I/O PORTS

Note 1: This data sheet summarizes the features of the dsPIC33FJ32GS406/606/608/610 and dsPIC33FJ64GS406/606/608/610 families of devices. It is not intended to be a comprehensive reference source. To complement the information in this data sheet, refer to **Section 10. “I/O Ports”** (DS70193) in the “dsPIC33F/PIC24H Family Reference Manual”, which is available from the Microchip web site (www.microchip.com).

2: Some registers and associated bits described in this section may not be available on all devices. Refer to **Section 4.0 “Memory Organization”** in this data sheet for device-specific register and bit information.

All of the device pins (except VDD, VSS, $\overline{\text{MCLR}}$ and OSC1/CLKI) are shared among the peripherals and the parallel I/O ports. All I/O input ports feature Schmitt Trigger inputs for improved noise immunity.

11.1 Parallel I/O (PIO) Ports

Generally a parallel I/O port that shares a pin with a peripheral is subservient to the peripheral. The peripheral's output buffer data and control signals are provided to a pair of multiplexers. The multiplexers select whether the peripheral or the associated port has ownership of the output data and control signals of the I/O pin. The logic also prevents “loop through”, in which a port's digital output can drive the input of a peripheral that shares the same pin. [Figure 11-1](#) shows how ports are shared with other peripherals and the associated I/O pin to which they are connected.

When a peripheral is enabled and the peripheral is actively driving an associated pin, the use of the pin as a general purpose output pin is disabled. The I/O pin can be read, but the output driver for the parallel port bit is disabled. If a peripheral is enabled, but the peripheral is not actively driving a pin, that pin can be driven by a port.

All port pins have three registers directly associated with their operation as digital I/O. The Data Direction register (TRISx) determines whether the pin is an input or an output. If the data direction bit is '1', then the pin is an input. All port pins are defined as inputs after a Reset. Reads from the latch (LATx) read the latch. Writes to the latch write the latch. Reads from the port (PORTx) read the port pins, while writes to the port pins write the latch.

Any bit and its associated data and control registers that are not valid for a particular device will be disabled. That means the corresponding LATx and TRISx registers and the port pin will read as zeros.

When a pin is shared with another peripheral or function that is defined as an input only, it is nevertheless regarded as a dedicated port because there is no other competing source of outputs.

FIGURE 11-1: BLOCK DIAGRAM OF A TYPICAL SHARED PORT STRUCTURE



11.2 Open-Drain Configuration

In addition to the PORT, LAT and TRIS registers for data control, some digital-only port pins can also be individually configured for either digital or open-drain output. This is controlled by the Open-Drain Control register, ODCx, associated with each port. Setting any of the bits configures the corresponding pin to act as an open-drain output.

The open-drain feature allows the generation of outputs higher than V_{DD} (for example, 5V) on any desired 5V tolerant pins by using external pull-up resistors. The maximum open-drain voltage allowed is the same as the maximum V_{IH} specification.

Refer to “[Pin Diagrams](#)” for the available pins and their functionality.

11.3 Configuring Analog Port Pins

The ADPCFG and TRIS registers control the operation of the analog-to-digital port pins. The port pins that are to function as analog inputs must have their corresponding TRIS bit set (input). If the TRIS bit is cleared (output), the digital output level (V_{OH} or V_{OL}) will be converted.

The ADPCFG and ADPCFG2 registers have a default value of 0x000; therefore, all pins that share ANx functions are analog (not digital) by default.

When the PORT register is read, all pins configured as analog input channels will read as cleared (a low level).

Pins configured as digital inputs will not convert an analog input. Analog levels on any pin defined as a digital input (including the ANx pins) can cause the input buffer to consume current that exceeds the device specifications.

11.4 I/O Port Write/Read Timing

One instruction cycle is required between a port direction change or port write operation and a read operation of the same port. Typically, this instruction would be a NOP. An example is shown in [Example 11-1](#).

11.5 Input Change Notification

The input change notification function of the I/O ports allows the dsPIC33FJ32GS406/606/608/610 and dsPIC33FJ64GS406/606/608/610 devices to generate interrupt requests to the processor in response to a Change-of-State (COS) on selected input pins. This feature can detect input Change-of-States even in Sleep mode, when the clocks are disabled. Depending on the device pin count, up to 30 external signals (CNx pin) can be selected (enabled) for generating an interrupt request on a Change-of-State.

Four control registers are associated with the CN module. The CNEN1 and CNEN2 registers contain the interrupt enable control bits for each of the CN input pins. Setting any of these bits enables a CN interrupt for the corresponding pins.

Each CN pin also has a weak pull-up connected to it. The pull-ups act as a current source connected to the pin, and eliminate the need for external resistors when the push button or keypad devices are connected. The pull-ups are enabled separately using the CNPU1 and CNPU2 registers, which contain the control bits for each of the CN pins. Setting any of the control bits enables the weak pull-ups for the corresponding pins.

Note: Pull-ups on change notification pins should always be disabled when the port pin is configured as a digital output.

EQUATION 11-1: PORT WRITE/READ EXAMPLE

```
MOV    0xFF00, W0           ; Configure PORTB<15:8> as inputs
MOV    W0, TRISBB          ; and PORTB<7:0> as outputs
NOP                               ; Delay 1 cycle
BTSS   PORTB, #13          ; Next Instruction
```

NOTES:

12.0 TIMER1

Note 1: This data sheet summarizes the features of the dsPIC33FJ32GS406/606/608/610 and dsPIC33FJ64GS406/606/608/610 families of devices. It is not intended to be a comprehensive reference source. To complement the information in this data sheet, refer to **Section 11. “Timers”** (DS70205) in the “dsPIC33F/PIC24H Family Reference Manual”, which is available from the Microchip web site (www.microchip.com).

2: Some registers and associated bits described in this section may not be available on all devices. Refer to **Section 4.0 “Memory Organization”** in this data sheet for device-specific register and bit information.

The Timer1 module is a 16-bit timer, which can serve as a time counter for the Real-Time Clock (RTC), or operate as a free-running interval timer/counter.

The Timer1 module has the following unique features over other timers:

- Can be operated from the low-power 32.767 kHz crystal oscillator available on the device
- Can be operated in Asynchronous Counter mode from an external clock source.
- The external clock input (T1CK) can optionally be synchronized to the internal device clock and the clock synchronization is performed after the prescaler.

The unique features of Timer1 allow it to be used for Real-Time Clock (RTC) applications. A block diagram of Timer1 is shown in [Figure 12-1](#).

The Timer1 module can operate in one of the following modes:

- Timer mode
- Gated Timer mode
- Synchronous Counter mode
- Asynchronous Counter mode

In Timer and Gated Timer modes, the input clock is derived from the internal instruction cycle clock (FCY). In Synchronous and Asynchronous Counter modes, the input clock is derived from the external clock input at the T1CK pin.

The Timer modes are determined by the following bits:

- Timer Clock Source Control bit: TCS (T1CON<1>)
- Timer Synchronization Control bit: TSYNC (T1CON<2>)
- Timer Gate Control bit: TGATE (T1CON<6>)

The timer control bit settings for different operating modes are given in the [Table 12-1](#).

TABLE 12-1: TIMER MODE SETTINGS

| Mode | TCS | TGATE | TSYNC |
|----------------------|-----|-------|-------|
| Timer | 0 | 0 | x |
| Gated Timer | 0 | 1 | x |
| Synchronous Counter | 1 | x | 1 |
| Asynchronous Counter | 1 | x | 0 |

FIGURE 12-1: 16-BIT TIMER1 MODULE BLOCK DIAGRAM



dsPIC33FJ32GS406/606/608/610 and dsPIC33FJ64GS406/606/608/610

REGISTER 12-1: T1CON: TIMER1 CONTROL REGISTER

| | | | | | | | |
|--------|-----|-------|-----|-----|-----|-----|-------|
| R/W-0 | U-0 | R/W-0 | U-0 | U-0 | U-0 | U-0 | U-0 |
| TON | — | TSIDL | — | — | — | — | — |
| bit 15 | | | | | | | bit 8 |

| | | | | | | | |
|-------|-------|------------|-------|-----|-------|-------|-------|
| U-0 | R/W-0 | R/W-0 | R/W-0 | U-0 | R/W-0 | R/W-0 | U-0 |
| — | TGATE | TCKPS<1:0> | | — | TSYNC | TCS | — |
| bit 7 | | | | | | | bit 0 |

Legend:

R = Readable bit W = Writable bit U = Unimplemented bit, read as '0'
 -n = Value at POR '1' = Bit is set '0' = Bit is cleared x = Bit is unknown

- bit 15 **TON:** Timer1 On bit
 1 = Starts 16-bit Timer1
 0 = Stops 16-bit Timer1
- bit 14 **Unimplemented:** Read as '0'
- bit 13 **TSIDL:** Timer1 Stop in Idle Mode bit
 1 = Discontinues module operation when device enters Idle mode
 0 = Continues module operation in Idle mode
- bit 12-7 **Unimplemented:** Read as '0'
- bit 6 **TGATE:** Timer1 Gated Time Accumulation Enable bit
 When TCS = 1:
 This bit is ignored.
 When TCS = 0:
 1 = Gated time accumulation is enabled
 0 = Gated time accumulation is disabled
- bit 5-4 **TCKPS<1:0>:**Timer1 Input Clock Prescale Select bits
 11 = 1:256
 10 = 1:64
 01 = 1:8
 00 = 1:1
- bit 3 **Unimplemented:** Read as '0'
- bit 2 **TSYNC:** Timer1 External Clock Input Synchronization Select bit
 When TCS = 1:
 1 = Synchronizes external clock input
 0 = Does not synchronize external clock input
 When TCS = 0:
 This bit is ignored.
- bit 1 **TCS:** Timer1 Clock Source Select bit
 1 = External clock from T1CK pin (on the rising edge)
 0 = Internal clock (FCY)
- bit 0 **Unimplemented:** Read as '0'

13.0 TIMER2/3/4/5 FEATURES

Note 1: This data sheet summarizes the features of the dsPIC33FJ32GS406/606/608/610 and dsPIC33FJ64GS406/606/608/610 families of devices. It is not intended to be a comprehensive reference source. To complement the information in this data sheet, refer to **Section 11. “Timers”** (DS70205) in the “dsPIC33F/PIC24H Family Reference Manual”, which is available from the Microchip web site (www.microchip.com).

2: Some registers and associated bits described in this section may not be available on all devices. Refer to **Section 4.0 “Memory Organization”** in this data sheet for device-specific register and bit information.

Timer2 and Timer4 are Type B timers that offer the following major features:

- A Type B Timer can be Concatenated with a Type C Timer to form a 32-Bit Timer
- External Clock Input (TxCK) is Always Synchronized to the Internal Device Clock and the Clock Synchronization is Performed after the Prescaler

Figure 13-1 shows a block diagram of the Type B timer.

Timer3 and Timer5 are Type C timers that offer the following major features:

- A Type C Timer can be Concatenated with a Type B Timer to form a 32-Bit Timer
- At Least One Type C Timer has the Ability to Trigger an Analog-to-Digital Conversion
- External Clock Input (TxCK) is Always Synchronized to the Internal Device Clock and the Clock Synchronization is Performed before the Prescaler

A block diagram of the Type C timer is shown in Figure 13-2.

Note: Timer3 is not available on all devices.

FIGURE 13-1: TYPE B TIMER BLOCK DIAGRAM (x = 2, 4)



FIGURE 13-2: TYPE C TIMER BLOCK DIAGRAM (x = 3, 5)



The Timer2/3/4/5 modules can operate in one of the following modes:

- Timer mode
- Gated Timer mode
- Synchronous Counter mode

In Timer and Gated Timer modes, the input clock is derived from the internal instruction cycle clock (FCY). In Synchronous Counter mode, the input clock is derived from the external clock input at the TxCK pin.

The timer modes are determined by the following bits:

- TCS (TxCON<1>): Timer Clock Source Control bit
- TGATE (TxCON<6>): Timer Gate Control bit

Timer control bit settings for different operating modes are given in the [Table 13-1](#).

TABLE 13-1: TIMER MODE SETTINGS

| Mode | TCS | TGATE |
|---------------------|-----|-------|
| Timer | 0 | 0 |
| Gated Timer | 0 | 1 |
| Synchronous Counter | 1 | x |

13.1 16-Bit Operation

To configure any of the timers for individual 16-bit operation:

1. Clear the T32 bit corresponding to that timer.
2. Select the timer prescaler ratio using the TCKPS<1:0> bits.
3. Set the Clock and Gating modes using the TCS and TGATE bits.
4. Load the timer period value into the PRx register.
5. If interrupts are required, set the interrupt enable bit, TxIE. Use the priority bits, TxIP<2:0>, to set the interrupt priority.
6. Set the TON bit.

13.2 32-Bit Operation

A 32-bit timer module can be formed by combining a Type B and a Type C 16-bit timer module. For 32-bit timer operation, the T32 control bit in the Type B Timer Control (TxCON<3>) register must be set. The Type C timer holds the most significant word (msw) and the Type B timer holds the least significant word (lsw) for 32-bit operation.

When configured for 32-bit operation, only the Type B Timer Control (TxCON) register bits are required for setup and control while the Type C Timer Control register bits are ignored (except the TSIDL bit).

For interrupt control, the combined 32-bit timer uses the interrupt enable, interrupt flag and interrupt priority control bits of the Type C timer. The interrupt control and status bits for the Type B timer are ignored during 32-bit timer operation.

The timers that can be combined to form a 32-bit timer are listed in [Table 13-2](#).

TABLE 13-2: 32-BIT TIMER

| Type B Timer (lsw) | Type C Timer (msw) |
|--------------------|--------------------|
| Timer2 | Timer3 |
| Timer4 | Timer5 |

A block diagram representation of the 32-bit timer module is shown in [Figure 13-3](#). The 32-timer module can operate in one of the following modes:

- Timer mode
- Gated Timer mode
- Synchronous Counter mode

To configure the timer features for 32-bit operation:

1. Set the T32 control bit.
2. Select the prescaler ratio for Timer2 using the TCKPS<1:0> bits.
3. Set the Clock and Gating modes using the corresponding TCS and TGATE bits.
4. Load the timer period value. PR3 contains the most significant word of the value, while PR2 contains the least significant word.
5. If interrupts are required, set the interrupt enable bit, T3IE. Use the priority bits, T3IP<2:0>, to set the interrupt priority. While Timer2 controls the timer, the interrupt appears as a Timer3 interrupt.
6. Set the corresponding TON bit.

FIGURE 13-3: 32-BIT TIMER BLOCK DIAGRAM



dsPIC33FJ32GS406/606/608/610 and dsPIC33FJ64GS406/606/608/610

REGISTER 13-1: TxCON: TIMERx CONTROL REGISTER (x = 2, 4)

| | | | | | | | |
|--------|-----|-------|-----|-----|-----|-----|-------|
| R/W-0 | U-0 | R/W-0 | U-0 | U-0 | U-0 | U-0 | U-0 |
| TON | — | TSIDL | — | — | — | — | — |
| bit 15 | | | | | | | bit 8 |

| | | | | | | | |
|-------|-------|------------|-------|-------|-----|-------|-------|
| U-0 | R/W-0 | R/W-0 | R/W-0 | R/W-0 | U-0 | R/W-0 | U-0 |
| — | TGATE | TCKPS<1:0> | | T32 | — | TCS | — |
| bit 7 | | | | | | | bit 0 |

Legend:

R = Readable bit

W = Writable bit

U = Unimplemented bit, read as '0'

-n = Value at POR

'1' = Bit is set

'0' = Bit is cleared

x = Bit is unknown

- bit 15 **TON:** Timerx On bit
When T32 = 1 (in 32-Bit Timer mode):
 1 = Starts 32-bit TMRx:TMRy timer pair
 0 = Stops 32-bit TMRx:TMRy timer pair
When T32 = 0 (in 16-Bit Timer mode):
 1 = Starts 16-bit timer
 0 = Stops 16-bit timer
- bit 14 **Unimplemented:** Read as '0'
- bit 13 **TSIDL:** Timerx Stop in Idle Mode bit
 1 = Discontinues timer operation when device enters Idle mode
 0 = Continues timer operation in Idle mode
- bit 12-7 **Unimplemented:** Read as '0'
- bit 6 **TGATE:** Timerx Gated Time Accumulation Enable bit
When TCS = 1:
 This bit is ignored.
When TCS = 0:
 1 = Gated time accumulation is enabled
 0 = Gated time accumulation is disabled
- bit 5-4 **TCKPS<1:0>:** Timerx Input Clock Prescale Select bits
 11 = 1:256 prescale value
 10 = 1:64 prescale value
 01 = 1:8 prescale value
 00 = 1:1 prescale value
- bit 3 **T32:** 32-Bit Timerx Mode Select bit
 1 = TMRx and TMRy form a 32-bit timer
 0 = TMRx and TMRy form a separate 16-bit timer
- bit 2 **Unimplemented:** Read as '0'
- bit 1 **TCS:** Timerx Clock Source Select bit
 1 = External clock from TxCK pin
 0 = Internal clock (FOSC/2)
- bit 0 **Unimplemented:** Read as '0'

dsPIC33FJ32GS406/606/608/610 and dsPIC33FJ64GS406/606/608/610

REGISTER 13-2: TyCON: TIMERY CONTROL REGISTER (y = 3, 5)

| | | | | | | | |
|--------------------|-----|----------------------|-----|-----|-----|-------|-----|
| R/W-0 | U-0 | R/W-0 | U-0 | U-0 | U-0 | U-0 | U-0 |
| TON ⁽²⁾ | — | TSIDL ⁽¹⁾ | — | — | — | — | — |
| bit 15 | | | | | | bit 8 | |

| | | | | | | | |
|-------|----------------------|---------------------------|-------|-----|-----|--------------------|-----|
| U-0 | R/W-0 | R/W-0 | R/W-0 | U-0 | U-0 | R/W-0 | U-0 |
| — | TGATE ⁽²⁾ | TCKPS<1:0> ⁽²⁾ | | — | — | TCS ⁽²⁾ | — |
| bit 7 | | | | | | bit 0 | |

Legend:

R = Readable bit W = Writable bit U = Unimplemented bit, read as '0'
-n = Value at POR '1' = Bit is set '0' = Bit is cleared x = Bit is unknown

- bit 15 **TON:** Timery On bit⁽²⁾
 1 = Starts 16-bit Timery
 0 = Stops 16-bit Timery
- bit 14 **Unimplemented:** Read as '0'
- bit 13 **TSIDL:** Timery Stop in Idle Mode bit⁽¹⁾
 1 = Discontinues timer operation when device enters Idle mode
 0 = Continue timers operation in Idle mode
- bit 12-7 **Unimplemented:** Read as '0'
- bit 6 **TGATE:** Timery Gated Time Accumulation Enable bit⁽²⁾
 When TCS = 1:
 This bit is ignored.
 When TCS = 0:
 1 = Gated time accumulation is enabled
 0 = Gated time accumulation is disabled
- bit 5-4 **TCKPS<1:0>:** Timery Input Clock Prescale Select bits⁽²⁾
 11 = 1:256 prescale value
 10 = 1:64 prescale value
 01 = 1:8 prescale value
 00 = 1:1 prescale value
- bit 3-2 **Unimplemented:** Read as '0'
- bit 1 **TCS:** Timery Clock Source Select bit⁽²⁾
 1 = External clock from TxCK pin
 0 = Internal clock (FOSC/2)
- bit 0 **Unimplemented:** Read as '0'

- Note 1:** When 32-bit timer operation is enabled (T32 = 1) in the Timer Control register (TxCON<3>), the TSIDL bit must be cleared to operate the 32-bit timer in Idle mode.
- 2:** When the 32-bit timer operation is enabled (T32 = 1) in the Timer Control (TxCON<3>) register, these bits have no effect.

NOTES:

14.0 INPUT CAPTURE

Note 1: This data sheet summarizes the features of the dsPIC33FJ32GS406/606/608/610 and dsPIC33FJ64GS406/606/608/610 families of devices. It is not intended to be a comprehensive reference source. To complement the information in this data sheet, refer to **Section 12. “Input Capture”** (DS70198) in the “dsPIC33F/PIC24H Family Reference Manual”, which is available from the Microchip web site (www.microchip.com).

2: Some registers and associated bits described in this section may not be available on all devices. Refer to **Section 4.0 “Memory Organization”** in this data sheet for device-specific register and bit information.

The input capture module is useful in applications requiring frequency (period) and pulse measurement. The dsPIC33FJ32GS406/606/608/610 and dsPIC33FJ64GS406/606/608/610 devices support up to two input capture channels.

The input capture module captures the 16-bit value of the selected Time Base register when an event occurs at the ICx pin. The events that cause a capture event are listed below in three categories:

- Simple Capture Event modes:
 - Capture timer value on every falling edge of input at ICx pin
 - Capture timer value on every rising edge of input at ICx pin
- Capture Timer Value on Every Edge (rising and falling)
- Prescaler Capture Event modes:
 - Capture timer value on every 4th rising edge of input at ICx pin
 - Capture timer value on every 16th rising edge of input at ICx pin

Each input capture channel can select one of the two 16-bit timers (Timer2 or Timer3) for the time base. The selected timer can use either an internal or external clock.

Other operational features include:

- Device Wake-up from Capture Pin during CPU Sleep and Idle modes
- Interrupt on Input Capture Event
- 4-Word FIFO Buffer for Capture Values
 - Interrupt optionally generated after 1, 2, 3 or 4 buffer locations are filled
- Use of Input Capture to provide Additional Sources of External Interrupts

FIGURE 14-1: INPUT CAPTURE x BLOCK DIAGRAM



14.1 Input Capture Registers

REGISTER 14-1: ICxCON: INPUT CAPTURE x CONTROL REGISTER (x = 1 or 2)

| | | | | | | | |
|--------|-----|--------|-----|-----|-----|-----|-------|
| U-0 | U-0 | R/W-0 | U-0 | U-0 | U-0 | U-0 | U-0 |
| — | — | ICSIDL | — | — | — | — | — |
| bit 15 | | | | | | | bit 8 |

| | | | | | | | |
|-------|----------|-------|---------|---------|----------|-------|-------|
| R/W-0 | R/W-0 | R/W-0 | R-0, HC | R-0, HC | R/W-0 | R/W-0 | R/W-0 |
| ICTMR | ICI<1:0> | | ICOV | ICBNE | ICM<2:0> | | |
| bit 7 | | | | | | | bit 0 |

| | |
|-------------------|------------------------------------|
| Legend: | HC = Hardware Clearable bit |
| R = Readable bit | W = Writable bit |
| -n = Value at POR | '1' = Bit is set |
| | U = Unimplemented bit, read as '0' |
| | '0' = Bit is cleared |
| | x = Bit is unknown |

- bit 15-14 **Unimplemented:** Read as '0'
- bit 13 **ICSIDL:** Input Capture x Stop in Idle Control bit
 1 = Input capture module halts in CPU Idle mode
 0 = Input capture module continues to operate in CPU Idle mode
- bit 12-8 **Unimplemented:** Read as '0'
- bit 7 **ICTMR:** Input Capture x Timer Select bit
 1 = TMR2 contents are captured on capture event
 0 = TMR3 contents are captured on capture event
- bit 6-5 **ICI<1:0>:** Select Number of Captures per Interrupt bits
 11 = Interrupt on every fourth capture event
 10 = Interrupt on every third capture event
 01 = Interrupt on every second capture event
 00 = Interrupt on every capture event
- bit 4 **ICOV:** Input Capture x Overflow Status Flag bit (read-only)
 1 = Input capture overflow occurred
 0 = No input capture overflow occurred
- bit 3 **ICBNE:** Input Capture x Buffer Empty Status bit (read-only)
 1 = Input capture buffer is not empty, at least one more capture value can be read
 0 = Input capture buffer is empty
- bit 2-0 **ICM<2:0>:** Input Capture Mode Select bits
 111 = Input capture functions as interrupt pin only when device is in Sleep or Idle mode. Rising edge detect-only; all other control bits are not applicable.
 110 = Unused (module disabled)
 101 = Capture mode, every 16th rising edge
 100 = Capture mode, every 4th rising edge
 011 = Capture mode, every rising edge
 010 = Capture mode, every falling edge
 001 = Capture mode, every edge (rising and falling). ICI<1:0> bits do not control interrupt generation for this mode.
 000 = Input capture module is turned off

15.0 OUTPUT COMPARE

Note 1: This data sheet summarizes the features of the dsPIC33FJ32GS406/606/608/610 and dsPIC33FJ64GS406/606/608/610 families of devices. It is not intended to be a comprehensive reference source. To complement the information in this data sheet, refer to **Section 13. “Output Compare”** (DS70209) in the “dsPIC33F/PIC24H Family Reference Manual”, which is available from the Microchip web site (www.microchip.com).

2: Some registers and associated bits described in this section may not be available on all devices. Refer to **Section 4.0 “Memory Organization”** in this data sheet for device-specific register and bit information.

The output compare module can select either Timer2 or Timer3 for its time base. The module compares the value of the timer with the value of one or two Compare registers depending on the operating mode selected. The state of the output pin changes when the timer value matches the Compare register value. The output compare module generates either a single output pulse, or a sequence of output pulses, by changing the state of the output pin on the compare match events. The output compare module can also generate interrupts on compare match events.

The output compare module has multiple operating modes:

- Active-Low One-Shot mode
- Active-High One-Shot mode
- Toggle mode
- Delayed One-Shot mode
- Continuous Pulse mode
- PWM mode without Fault Protection
- PWM mode with Fault Protection

FIGURE 15-1: OUTPUT COMPARE MODULE BLOCK DIAGRAM



15.1 Output Compare Modes

Configure the Output Compare modes by setting the appropriate Output Compare Mode (OCM<2:0>) bits in the Output Compare Control (OCxCON<2:0>) register. Table 15-1 lists the different bit settings for the Output Compare modes. Figure 15-2 illustrates the output compare operation for various modes. The user

application must disable the associated timer when writing to the Output Compare Control registers to avoid malfunctions.

Note: See Section 13. “Output Compare” (DS70209) in the “dsPIC33F/PIC24H Family Reference Manual” for OCxR and OCxRS register restrictions.

TABLE 15-1: OUTPUT COMPARE MODES

| OCM<2:0> | Mode | OCx Pin Initial State | OCx Interrupt Generation |
|----------|------------------------------|--|----------------------------------|
| 000 | Module Disabled | Controlled by GPIO register | — |
| 001 | Active-Low One-Shot | 0 | OCx rising edge |
| 010 | Active-High One-Shot | 1 | OCx falling edge |
| 011 | Toggle | Current output is maintained | OCx rising and falling edge |
| 100 | Delayed One-Shot | 0 | OCx falling edge |
| 101 | Continuous Pulse | 0 | OCx falling edge |
| 110 | PWM without Fault Protection | '0' if OCxR is zero '1' if OCxR is non-zero | No interrupt |
| 111 | PWM with Fault Protection | '0' if OCxR is zero '1' if OCxR is non-zero | OCFA falling edge for OC1 to OC4 |

FIGURE 15-2: OUTPUT COMPARE OPERATION



dsPIC33FJ32GS406/606/608/610 and dsPIC33FJ64GS406/606/608/610

REGISTER 15-1: OCxCON: OUTPUT COMPARE x CONTROL REGISTER (x = 1, 2)

| | | | | | | | |
|--------|-----|--------|-----|-----|-----|-------|-----|
| U-0 | U-0 | R/W-0 | U-0 | U-0 | U-0 | U-0 | U-0 |
| — | — | OCSIDL | — | — | — | — | — |
| bit 15 | | | | | | bit 8 | |

| | | | | | | | |
|-------|-----|-----|---------|--------|----------|-------|-------|
| U-0 | U-0 | U-0 | R-0, HC | R/W-0 | R/W-0 | R/W-0 | R/W-0 |
| — | — | — | OCFLT | OCTSEL | OCM<2:0> | | |
| bit 7 | | | | | | bit 0 | |

| | |
|-------------------|------------------------------------|
| Legend: | HC = Hardware Clearable bit |
| R = Readable bit | W = Writable bit |
| -n = Value at POR | '1' = Bit is set |
| | U = Unimplemented bit, read as '0' |
| | '0' = Bit is cleared |
| | x = Bit is unknown |

- bit 15-14 **Unimplemented:** Read as '0'
- bit 13 **OCSIDL:** Output Compare x Stop in Idle Mode Control bit
 1 = Output Compare x halts in CPU Idle mode
 0 = Output Compare x continues to operate in CPU Idle mode
- bit 12-5 **Unimplemented:** Read as '0'
- bit 4 **OCFLT:** PWM Fault Condition Status bit
 1 = PWM Fault condition has occurred (cleared in hardware only)
 0 = No PWM Fault condition has occurred (this bit is only used when OCM<2:0> = 111)
- bit 3 **OCTSEL:** Output Compare x Timer Select bit
 1 = Timer3 is the clock source for Compare x
 0 = Timer2 is the clock source for Compare x
- bit 2-0 **OCM<2:0>:** Output Compare Mode Select bits
 111 = PWM mode on OCx, Fault pin is enabled
 110 = PWM mode on OCx, Fault pin is disabled
 101 = Initializes OCx pin low, generates continuous output pulses on OCx pin
 100 = Initializes OCx pin low, generates single output pulse on OCx pin
 011 = Compare event toggles OCx pin
 010 = Initializes OCx pin high, compare event forces OCx pin low
 001 = Initializes OCx pin low, compare event forces OCx pin high
 000 = Output compare channel is disabled

NOTES:

16.0 HIGH-SPEED PWM

Note 1: This data sheet summarizes the features of the dsPIC33FJ32GS406/606/608/610 and dsPIC33FJ64GS406/606/608/610 families of devices. It is not intended to be a comprehensive reference source. To complement the information in this data sheet, refer to **Section 43. “High-Speed PWM”** (DS70323) in the “*dsPIC33F/PIC24H Family Reference Manual*”, which is available from the Microchip web site (www.microchip.com).

2: Some registers and associated bits described in this section may not be available on all devices. Refer to **Section 4.0 “Memory Organization”** in this data sheet for device-specific register and bit information.

The High-Speed PWM module on the dsPIC33FJ32GS406/606/608/610 and dsPIC33FJ64GS406/606/608/610 devices supports a wide variety of PWM modes and output formats. This PWM module is ideal for power conversion applications, such as:

- AC/DC Converters
- DC/DC Converters
- Power Factor Correction
- Uninterruptible Power Supply (UPS)
- Inverters
- Battery Chargers
- Digital Lighting

16.1 Features Overview

The High-Speed PWM module incorporates the following features:

- Two Master Time Base modules
- Up to Nine PWM Generators with up to 18 Outputs
- Two PWM Outputs per PWM Generator
- Individual Time Base and Duty Cycle for each PWM Output
- Duty Cycle, Dead Time, Phase Shift and Frequency Resolution of 1.04 ns
- Independent Fault and Current-Limit Inputs for Eight PWM Outputs
- Redundant Output
- True Independent Output
- Center-Aligned PWM mode
- Output Override Control
- Chop mode (also known as Gated mode)
- Special Event Trigger
- Prescaler for Input Clock

- Dual Trigger from PWM to Analog-to-Digital Converter (ADC) per PWM Period
- PWMxL and PWMxH Output Pin Swapping
- Independent PWM Frequency, Duty Cycle and Phase Shift Changes
- Current Compensation
- Enhanced Leading-Edge Blanking (LEB) Functionality
- PWM Capture Functionality

Note: Duty cycle, dead-time, phase shift and frequency resolution is 8.32 ns in Center-Aligned PWM mode.

Figure 16-1 conceptualizes the PWM module in a simplified block diagram. Figure 16-2 illustrates how the module hardware is partitioned for each PWM output pair for the Complementary PWM mode.

The PWM module contains nine PWM generators. The module has up to 18 PWM output pins: PWM1H/PWM1L through PWM9H/PWM9L. For complementary outputs, these 18 I/O pins are grouped into high/low pairs.

16.2 Feature Description

The PWM module is designed for applications that require:

- High-resolution at high PWM frequencies
- The ability to drive Standard, Edge-Aligned, Center-Aligned Complementary mode, and Push-Pull mode outputs
- The ability to create multiphase PWM outputs

For Center-Aligned mode, the duty cycle, period phase and dead-time resolutions will be 8.32 ns.

Two common, medium power converter topologies are push-pull and half-bridge. These designs require the PWM output signal to be switched between alternate pins, as provided by the Push-Pull PWM mode.

Phase-shifted PWM describes the situation where each PWM generator provides outputs, but the phase relationship between the generator outputs is specifiable and changeable.

Multiphase PWM is often used to improve DC/DC Converter load transient response, and reduce the size of output filter capacitors and inductors. Multiple DC/DC Converters are often operated in parallel, but phase-shifted in time. A single PWM output operating at 250 kHz has a period of 4 μ s, but an array of four PWM channels, staggered by 1 μ s each, yields an effective switching frequency of 1 MHz. Multiphase PWM applications typically use a fixed-phase relationship.

Variable phase PWM is useful in Zero Voltage Transition (ZVT) power converters. Here, the PWM duty cycle is always 50%, and the power flow is controlled by varying the relative phase shift between the two PWM generators.

FIGURE 16-1: HIGH-SPEED PWMx MODULE ARCHITECTURAL DIAGRAM



FIGURE 16-2: SIMPLIFIED CONCEPTUAL BLOCK DIAGRAM OF THE HIGH-SPEED PWMx



16.3 Control Registers

The following registers control the operation of the High-Speed PWM module.

- PTCN: PWM Time Base Control Register
- PTCN2: PWM Clock Divider Select Register 2
- PTPER: Primary Master Time Base Period Register^(1,2)
- SEVTCMP: PWM Special Event Compare Register⁽¹⁾
- STCON: PWM Secondary Master Time Base Control Register
- STCON2: PWM Secondary Clock Divider Select Register 2
- STPER: Secondary Master Time Base Period Register
- SSEVTCMP: PWM Secondary Special Event Compare Register
- CHOP: PWM Chop Clock Generator Register⁽¹⁾
- MDC: PWM Master Duty Cycle Register^(1,2)
- PWMCONx: PWM Control x Register
- PDCx: PWM Generator Duty Cycle x Register^(1,2,3)
- PHASEx: PWM Primary Phase Shift x Register^(1,2)
- DTRx: PWM Dead-Time x Register
- ALTDTRx: PWM Alternate Dead-Time x Register
- SDCx: PWM Secondary Duty Cycle x Register^(1,2,3)
- SPHASEx: PWM Secondary Phase Shift x Register^(1,2)
- TRGCONx: PWM Trigger Control x Register
- IOCONx: PWM I/O Control x Register
- FCLCONx: PWM Fault Current-Limit Control x Register
- TRIGx: PWM Primary Trigger x Compare Value Register
- STRIGx: PWM Secondary Trigger x Compare Value Register⁽¹⁾
- LEBCONx: Leading-Edge Blanking Control x Register
- LEBDLYx: Leading-Edge Blanking Delay x Register
- AUXCONx: PWM Auxiliary Control x Register
- PWMCAPx: Primary PWM Time Base Capture x Register

dsPIC33FJ32GS406/606/608/610 and dsPIC33FJ64GS406/606/608/610

REGISTER 16-1: PTCON: PWM TIME BASE CONTROL REGISTER

| | | | | | | | |
|--------|-----|--------|---------|-------|---------------------|------------------------|------------------------|
| R/W-0 | U-0 | R/W-0 | HS/HC-0 | R/W-0 | R/W-0 | R/W-0 | R/W-0 |
| PTEN | — | PTSIDL | SESTAT | SEIEN | EIPU ⁽¹⁾ | SYNCPOL ⁽¹⁾ | SYNCOEN ⁽¹⁾ |
| bit 15 | | | | | | bit 8 | |

| | | | | | | | |
|-----------------------|-----------------------------|-------|-------|----------------------------|-------|-------|-------|
| R/W-0 | R/W-0 | R/W-0 | R/W-0 | R/W-0 | R/W-0 | R/W-0 | R/W-0 |
| SYNCEN ⁽¹⁾ | SYNCSRC<2:0> ⁽¹⁾ | | | SEVTPS<3:0> ⁽¹⁾ | | | |
| bit 7 | | | | | | bit 0 | |

| | | |
|-------------------|-----------------------------|--|
| Legend: | HC = Hardware Clearable bit | HS = Hardware Settable bit |
| R = Readable bit | W = Writable bit | U = Unimplemented bit, read as '0' |
| -n = Value at POR | '1' = Bit is set | '0' = Bit is cleared x = Bit is unknown |

- bit 15 **PTEN:** PWM Module Enable bit
1 = PWM module is enabled
0 = PWM module is disabled
- bit 14 **Unimplemented:** Read as '0'
- bit 13 **PTSIDL:** PWM Time Base Stop in Idle Mode bit
1 = PWM time base halts in CPU Idle mode
0 = PWM time base runs in CPU Idle mode
- bit 12 **SESTAT:** Special Event Interrupt Status bit
1 = Special Event Interrupt is pending
0 = Special Event Interrupt is not pending
- bit 11 **SEIEN:** Special Event Interrupt Enable bit
1 = Special Event Interrupt is enabled
0 = Special Event Interrupt is disabled
- bit 10 **EIPU:** Enable Immediate Period Updates bit⁽¹⁾
1 = Active Period register is updated immediately
0 = Active Period register updates occur on PWM cycle boundaries
- bit 9 **SYNCPOL:** Synchronize Input and Output Polarity bit⁽¹⁾
1 = SYNCIx/SYNCO1 polarity is inverted (active-low)
0 = SYNCIx/SYNCO1 is active-high
- bit 8 **SYNCOEN:** Primary Time Base Synchronization Enable bit⁽¹⁾
1 = SYNCO1 output is enabled
0 = SYNCO1 output is disabled
- bit 7 **SYNCEN:** External Time Base Synchronization Enable bit⁽¹⁾
1 = External synchronization of primary time base is enabled
0 = External synchronization of primary time base is disabled
- bit 6-4 **SYNCSRC<2:0>:** Synchronous Source Selection bits⁽¹⁾
111 = Reserved
101 = Reserved
100 = Reserved
011 = SYNCI4
010 = SYNCI3
001 = SYNCI2
000 = SYNCI1

Note 1: These bits should be changed only when PTEN = 0. In addition, when using the SYNCIx feature, the user application must program the Period register with a value that is slightly larger than the expected period of the external synchronization input signal.

REGISTER 16-1: PTCON: PWM TIME BASE CONTROL REGISTER (CONTINUED)

bit 3-0 **SEVTPS<3:0>**: PWM Special Event Trigger Output Postscaler Select bits⁽¹⁾

- 1111 = 1:16 Postscaler generates special event trigger on every sixteenth compare match event
-
-
-
- 0001 = 1:2 Postscaler generates special event trigger on every second compare match event
- 0000 = 1:1 Postscaler generates special event trigger on every compare match event

Note 1: These bits should be changed only when PTEN = 0. In addition, when using the SYNCIx feature, the user application must program the Period register with a value that is slightly larger than the expected period of the external synchronization input signal.

dsPIC33FJ32GS406/606/608/610 and dsPIC33FJ64GS406/606/608/610

REGISTER 16-2: PTCON2: PWM CLOCK DIVIDER SELECT REGISTER 2

| | | | | | | | |
|--------|-----|-----|-----|-----|-----------------------------|-------|-------|
| U-0 | U-0 | U-0 | U-0 | U-0 | U-0 | U-0 | U-0 |
| — | — | — | — | — | — | — | — |
| bit 15 | | | | | | | bit 8 |
| U-0 | U-0 | U-0 | U-0 | U-0 | R/W-0 | R/W-0 | R/W-0 |
| — | — | — | — | — | PCLKDIV<2:0> ⁽¹⁾ | | |
| bit 7 | | | | | | | bit 0 |

Legend:

R = Readable bit W = Writable bit U = Unimplemented bit, read as '0'
 -n = Value at POR '1' = Bit is set '0' = Bit is cleared x = Bit is unknown

bit 15-3 **Unimplemented:** Read as '0'

bit 2-0 **PCLKDIV<2:0>:** PWM Input Clock Prescaler (Divider) Select bits⁽¹⁾

- 111 = Reserved
- 110 = Divide-by-64, maximum PWM timing resolution
- 101 = Divide-by-32, maximum PWM timing resolution
- 100 = Divide-by-16, maximum PWM timing resolution
- 011 = Divide-by-8, maximum PWM timing resolution
- 010 = Divide-by-4, maximum PWM timing resolution
- 001 = Divide-by-2, maximum PWM timing resolution
- 000 = Divide-by-1, maximum PWM timing resolution (power-on default)

Note 1: These bits should be changed only when PTEN = 0. Changing the clock selection during operation will yield unpredictable results.

REGISTER 16-3: PTPER: PRIMARY MASTER TIME BASE PERIOD REGISTER^(1,2)

| | | | | | | | |
|-------------|-------|-------|-------|-------|-------|-------|-------|
| R/W-1 | R/W-1 | R/W-1 | R/W-1 | R/W-1 | R/W-1 | R/W-1 | R/W-1 |
| PTPER<15:8> | | | | | | | |
| bit 15 | | | | | | | bit 8 |
| R/W-1 | R/W-1 | R/W-1 | R/W-1 | R/W-1 | R/W-0 | R/W-0 | R/W-0 |
| PTPER<7:0> | | | | | | | |
| bit 7 | | | | | | | bit 0 |

Legend:

R = Readable bit W = Writable bit U = Unimplemented bit, read as '0'
 -n = Value at POR '1' = Bit is set '0' = Bit is cleared x = Bit is unknown

bit 15-0 **PTPER<15:0>:** Primary Master Time Base (PMTMR) Period Value bits

- Note 1:** The PWM time base has a minimum value of 0x0010 and a maximum value of 0xFFFF8.
Note 2: Any period value that is less than 0x0028 must have the Least Significant 3 bits set to '0', thus yielding a period resolution at 8.32 ns (at fastest auxiliary clock rate).

dsPIC33FJ32GS406/606/608/610 and dsPIC33FJ64GS406/606/608/610

REGISTER 16-4: SEVTCMP: PWM SPECIAL EVENT COMPARE REGISTER⁽¹⁾

| | | | | | | | |
|---------------|-------|-------|-------|-------|-------|-------|-------|
| R/W-0 | R/W-0 | R/W-0 | R/W-0 | R/W-0 | R/W-0 | R/W-0 | R/W-0 |
| SEVTCMP<15:8> | | | | | | | |
| bit 15 | | | | | | | bit 8 |

| | | | | | | | |
|--------------|-------|-------|-------|-------|-----|-----|-------|
| R/W-0 | R/W-0 | R/W-0 | R/W-0 | R/W-0 | U-0 | U-0 | U-0 |
| SEVTCMP<7:3> | | | | | — | — | — |
| bit 7 | | | | | | | bit 0 |

Legend:

R = Readable bit

W = Writable bit

U = Unimplemented bit, read as '0'

-n = Value at POR

'1' = Bit is set

'0' = Bit is cleared

x = Bit is unknown

bit 15-3 **SEVTCMP<15:3>**: Special Event Compare Count Value bits

bit 2-0 **Unimplemented**: Read as '0'

Note 1: One LSB = 1.04 ns (at fastest auxiliary clock rate); therefore, the minimum SEVTCMP resolution is 8.32 ns.

REGISTER 16-5: STCON: PWM SECONDARY MASTER TIME BASE CONTROL REGISTER

| | | | | | | | |
|--------|-----|-----|---------|-------|---------------------|---------|---------|
| U-0 | U-0 | U-0 | HS/HC-0 | R/W-0 | R/W-0 | R/W-0 | R/W-0 |
| — | — | — | SESTAT | SEIEN | EIPU ⁽¹⁾ | SYNCPOL | SYNCOEN |
| bit 15 | | | | | | bit 8 | |

| | | | | | | | |
|--------|--------------|-------|-------|-------------|-------|-------|-------|
| R/W-0 | R/W-0 | R/W-0 | R/W-0 | R/W-0 | R/W-0 | R/W-0 | R/W-0 |
| SYNCEN | SYNCSRC<2:0> | | | SEVTPS<3:0> | | | |
| bit 7 | | | | | | bit 0 | |

| | | |
|-------------------|-----------------------------|------------------------------------|
| Legend: | HC = Hardware Clearable bit | HS = Hardware Settable bit |
| R = Readable bit | W = Writable bit | U = Unimplemented bit, read as '0' |
| -n = Value at POR | '1' = Bit is set | '0' = Bit is cleared |
| | | x = Bit is unknown |

- bit 15-13 **Unimplemented:** Read as '0'
- bit 12 **SESTAT:** Special Event Interrupt Status bit
 - 1 = Secondary Special Event Interrupt is pending
 - 0 = Secondary Special Event Interrupt is not pending
- bit 11 **SEIEN:** Special Event Interrupt Enable bit
 - 1 = Secondary Special Event Interrupt is enabled
 - 0 = Secondary Special Event Interrupt is disabled
- bit 10 **EIPU:** Enable Immediate Period Updates bit⁽¹⁾
 - 1 = Active Secondary Period register is updated immediately
 - 0 = Active Secondary Period register updates occur on PWM cycle boundaries
- bit 9 **SYNCPOL:** Synchronize Input and Output Polarity bit
 - 1 = SYNCIx/SYNCO2 polarity is inverted (active-low)
 - 0 = SYNCIx/SYNCO2 polarity is active-high
- bit 8 **SYNCOEN:** Secondary Master Time Base Synchronization Enable bit
 - 1 = SYNCO2 output is enabled.
 - 0 = SYNCO2 output is disabled
- bit 7 **SYNCEN:** External Secondary Master Time Base Synchronization Enable bit
 - 1 = External synchronization of secondary time base is enabled
 - 0 = External synchronization of secondary time base is disabled
- bit 6-4 **SYNCSRC<2:0>:** PWM Secondary Time Base Synchronization Source Selection bits
 - 111 = Reserved
 - 101 = Reserved
 - 100 = Reserved
 - 011 = SYNCI4
 - 010 = SYNCI3
 - 001 = SYNCI2
 - 000 = SYNCI1
- bit 3-0 **SEVTPS<3:0>:** PWM Secondary Special Event Trigger Output Postscaler Select bits
 - 1111 = 1:16 Postscale
 - 0001 = 1:2 Postscale
 -
 -
 -
 - 0000 = 1:1 Postscale

Note 1: This bit only applies to the secondary master time base period.

dsPIC33FJ32GS406/606/608/610 and dsPIC33FJ64GS406/606/608/610

REGISTER 16-6: STCON2: PWM SECONDARY CLOCK DIVIDER SELECT REGISTER 2

| | | | | | | | |
|--------|-----|-----|-----|-----|-----|-----|-------|
| U-0 | U-0 | U-0 | U-0 | U-0 | U-0 | U-0 | U-0 |
| — | — | — | — | — | — | — | — |
| bit 15 | | | | | | | bit 8 |

| | | | | | | | |
|-------|-----|-----|-----|-----|-----------------------------|-------|-------|
| U-0 | U-0 | U-0 | U-0 | U-0 | R/W-0 | R/W-0 | R/W-0 |
| — | — | — | — | — | PCLKDIV<2:0> ⁽¹⁾ | | |
| bit 7 | | | | | | | bit 0 |

Legend:

R = Readable bit W = Writable bit U = Unimplemented bit, read as '0'
 -n = Value at POR '1' = Bit is set '0' = Bit is cleared x = Bit is unknown

- bit 15-3 **Unimplemented:** Read as '0'
- bit 2-0 **PCLKDIV<2:0>:** PWM Input Clock Prescaler (Divider) Select bits⁽¹⁾
- 111 = Reserved
 - 110 = Divide-by-64, maximum PWM timing resolution
 - 101 = Divide-by-32, maximum PWM timing resolution
 - 100 = Divide-by-16, maximum PWM timing resolution
 - 011 = Divide-by-8, maximum PWM timing resolution
 - 010 = Divide-by-4, maximum PWM timing resolution
 - 001 = Divide-by-2, maximum PWM timing resolution
 - 000 = Divide-by-1, maximum PWM timing resolution (power-on default)

Note 1: These bits should be changed only when PTEN = 0. Changing the clock selection during operation will yield unpredictable results.

REGISTER 16-7: STPER: SECONDARY MASTER TIME BASE PERIOD REGISTER

| | | | | | | | |
|-------------|-------|-------|-------|-------|-------|-------|-------|
| R/W-1 | R/W-1 | R/W-1 | R/W-1 | R/W-1 | R/W-1 | R/W-1 | R/W-1 |
| STPER<15:8> | | | | | | | |
| bit 15 | | | | | | | bit 8 |

| | | | | | | | |
|------------|-------|-------|-------|-------|-------|-------|-------|
| R/W-1 | R/W-1 | R/W-1 | R/W-1 | R/W-1 | R/W-0 | R/W-0 | R/W-0 |
| STPER<7:0> | | | | | | | |
| bit 7 | | | | | | | bit 0 |

Legend:

R = Readable bit W = Writable bit U = Unimplemented bit, read as '0'
 -n = Value at POR '1' = Bit is set '0' = Bit is cleared x = Bit is unknown

- bit 15-0 **STPER<15:0>:** Secondary Master Time Base (SMTMR) Period Value bits

REGISTER 16-8: SSEVTCMP: PWM SECONDARY SPECIAL EVENT COMPARE REGISTER

| | | | | | | | |
|----------------|-------|-------|-------|-------|-------|-------|-------|
| R/W-0 | R/W-0 | R/W-0 | R/W-0 | R/W-0 | R/W-0 | R/W-0 | R/W-0 |
| SSEVTCMP<15:8> | | | | | | | |
| bit 15 | | | | | | | bit 8 |

| | | | | | | | |
|---------------|-------|-------|-------|-------|-----|-----|-------|
| R/W-0 | R/W-0 | R/W-0 | R/W-0 | R/W-0 | U-0 | U-0 | U-0 |
| SSEVTCMP<7:3> | | | | | — | — | — |
| bit 7 | | | | | | | bit 0 |

Legend:
 R = Readable bit W = Writable bit U = Unimplemented bit, read as '0'
 -n = Value at POR '1' = Bit is set '0' = Bit is cleared x = Bit is unknown

bit 15-3 **SSEVTCMP<15:3>**: Special Event Compare Count Value bits
 bit 2-0 **Unimplemented**: Read as '0'

REGISTER 16-9: CHOP: PWM CHOP CLOCK GENERATOR REGISTER⁽¹⁾

| | | | | | | | |
|----------|-----|-----|-----|-----|-----|-----------|-------|
| R/W-0 | U-0 | U-0 | U-0 | U-0 | U-0 | R/W-0 | R/W-0 |
| CHPCLKEN | — | — | — | — | — | CHOP<9:8> | |
| bit 15 | | | | | | | bit 8 |

| | | | | | | | |
|-----------|-------|-------|-------|-------|-----|-----|-------|
| R/W-0 | R/W-0 | R/W-0 | R/W-0 | R/W-0 | U-0 | U-0 | U-0 |
| CHOP<7:3> | | | | | — | — | — |
| bit 7 | | | | | | | bit 0 |

Legend:
 R = Readable bit W = Writable bit U = Unimplemented bit, read as '0'
 -n = Value at POR '1' = Bit is set '0' = Bit is cleared x = Bit is unknown

bit 15 **CHPCLKEN**: Enable Chop Clock Generator bit
 1 = Chop clock generator is enabled
 0 = Chop clock generator is disabled

bit 14-10 **Unimplemented**: Read as '0'

bit 9-3 **CHOP<9:3>**: Chop Clock Divider bits
 Value in 8.32 ns increments. The frequency of the chop clock signal is given by the following expression:
 $Chop\ Frequency = 1 / (16.64 * (CHOP<7:3> + 1) * Primary\ Master\ PWM\ Input\ Clock\ Period)$

bit 2-0 **Unimplemented**: Read as '0'

Note 1: The chop clock generator operates with the primary PWM clock prescaler (PCLKDIV<2:0>) in the PTCON2 register ([Register 16-2](#)).

dsPIC33FJ32GS406/606/608/610 and dsPIC33FJ64GS406/606/608/610

REGISTER 16-10: MDC: PWM MASTER DUTY CYCLE REGISTER^(1,2)

| | | | | | | | |
|-----------|-------|-------|-------|-------|-------|-------|-------|
| R/W-0 | R/W-0 | R/W-0 | R/W-0 | R/W-0 | R/W-0 | R/W-0 | R/W-0 |
| MDC<15:8> | | | | | | | |
| bit 15 | | | | bit 8 | | | |

| | | | | | | | |
|----------|-------|-------|-------|-------|-------|-------|-------|
| R/W-0 | R/W-0 | R/W-0 | R/W-0 | R/W-0 | R/W-0 | R/W-0 | R/W-0 |
| MDC<7:0> | | | | | | | |
| bit 7 | | | | bit 0 | | | |

Legend:

R = Readable bit

W = Writable bit

U = Unimplemented bit, read as '0'

-n = Value at POR

'1' = Bit is set

'0' = Bit is cleared

x = Bit is unknown

bit 15-0 **MDC<15:0>**: PWM Master Duty Cycle Value bits

Note 1: The smallest pulse width that can be generated on the PWM output corresponds to a value of 0x0008, while the maximum pulse width generated corresponds to a value of Period – 0x0008.

2: As the duty cycle gets closer to 0% or 100% of the PWM period (0 to 40 ns, depending on the mode of operation), the PWM duty cycle resolution will increase from 1 to 3 LSBs.

REGISTER 16-11: PWMCONx: PWM CONTROL x REGISTER

| | | | | | | | |
|------------------------|-----------------------|---------|---------|--------|---------|--------------------|---------------------|
| HS/HC-0 | HS/HC-0 | HS/HC-0 | R/W-0 | R/W-0 | R/W-0 | R/W-0 | R/W-0 |
| FLTSTAT ⁽¹⁾ | CLSTAT ⁽¹⁾ | TRGSTAT | FLTIEEN | CLIEEN | TRGIEEN | ITB ⁽³⁾ | MDCS ⁽³⁾ |
| bit 15 | | | | | | | bit 8 |

| | | | | | | | |
|----------|-------|---------------------|-----|-------|------------------------|----------------------|-------|
| R/W-0 | R/W-0 | R/W-0 | U-0 | R/W-0 | R/W-0 | R/W-0 | R/W-0 |
| DTC<1:0> | | DTCP ⁽⁴⁾ | — | MTBS | CAM ^(2,3,5) | XPRES ⁽⁶⁾ | IUE |
| bit 7 | | | | | | | bit 0 |

| | | |
|-------------------|-----------------------------|------------------------------------|
| Legend: | HC = Hardware Clearable bit | HS = Hardware Settable bit |
| R = Readable bit | W = Writable bit | U = Unimplemented bit, read as '0' |
| -n = Value at POR | '1' = Bit is set | '0' = Bit is cleared |
| | | x = Bit is unknown |

- bit 15 **FLTSTAT:** Fault Interrupt Status bit⁽¹⁾
 1 = Fault interrupt is pending
 0 = No Fault interrupt is pending
 This bit is cleared by setting FLTIEEN = 0.
- bit 14 **CLSTAT:** Current-Limit Interrupt Status bit⁽¹⁾
 1 = Current-limit interrupt is pending
 0 = No current-limit interrupt is pending
 This bit is cleared by setting CLIEEN = 0.
- bit 13 **TRGSTAT:** Trigger Interrupt Status bit
 1 = Trigger interrupt is pending
 0 = No trigger interrupt is pending
 This bit is cleared by setting TRGIEEN = 0.
- bit 12 **FLTIEEN:** Fault Interrupt Enable bit
 1 = Fault interrupt is enabled
 0 = Fault interrupt is disabled and FLTSTAT bit is cleared
- bit 11 **CLIEEN:** Current-Limit Interrupt Enable bit
 1 = Current-limit interrupt is enabled
 0 = Current-limit interrupt is disabled and CLSTAT bit is cleared
- bit 10 **TRGIEEN:** Trigger Interrupt Enable bit
 1 = A trigger event generates an interrupt request
 0 = Trigger event interrupts are disabled and TRGSTAT bit is cleared
- bit 9 **ITB:** Independent Time Base Mode bit⁽³⁾
 1 = PHASEx/SPHASEx registers provide time base period for this PWM generator
 0 = PTPER register provides timing for this PWM generator
- bit 8 **MDCS:** Master Duty Cycle Register Select bit⁽³⁾
 1 = MDC register provides duty cycle information for this PWM generator
 0 = PDCx and SDCx registers provide duty cycle information for this PWM generator

- Note 1:** Software must clear the interrupt status here and in the corresponding IFSx bit in the interrupt controller.
- 2:** The Independent Time Base mode (ITB = 1) must be enabled to use Center-Aligned mode. If ITB = 0, the CAM bit is ignored.
- 3:** These bits should not be changed after the PWM is enabled by setting PTEN (PTCON<15>) = 1.
- 4:** For DTCP to be effective, DTC<1:0> must be set to '11'; otherwise, DTCP is ignored.
- 5:** Center-Aligned mode ignores the Least Significant 3 bits of the Duty Cycle, Phase and Dead-Time registers. The highest Center-Aligned mode resolution available is 8.32 ns with the clock prescaler set to the fastest clock.
- 6:** Configure CLMOD (FCLCONX<8>) = 0 and ITB (PWMCONx<9>) = 1 to operate in External Period Reset mode.

REGISTER 16-11: PWMCONx: PWM CONTROL x REGISTER (CONTINUED)

- bit 7-6 **DTC<1:0>**: Dead-Time Control bits
11 = Dead-Time Compensation mode
10 = Dead-time function is disabled
01 = Negative dead time is actively applied for Complementary Output mode
00 = Positive dead time is actively applied for all output modes
- bit 5 **DTCP**: Dead-Time Compensation Polarity bit⁽⁴⁾
1 = If DTCMPx = 0, PWMxL is shortened and PWMxH is lengthened
 If DTCMPx = 1, PWMxH is shortened and PWMxL is lengthened
0 = If DTCMPx = 0, PWMxH is shortened and PWMxL is lengthened
 If DTCMPx = 1, PWMxL is shortened and PWMxH is lengthened
- bit 4 **Unimplemented**: Read as '0'
- bit 3 **MTBS**: Master Time Base Select bit
1 = PWM generator uses the secondary master time base for synchronization and the clock source for the PWM generation logic (if secondary time base is available)
0 = PWM generator uses the primary master time base for synchronization and the clock source for the PWM generation logic
- bit 2 **CAM**: Center-Aligned Mode Enable bit^(2,3,5)
1 = Center-Aligned mode is enabled
0 = Edge-Aligned mode is enabled
- bit 1 **XPRES**: External PWM Reset Control bit⁽⁶⁾
1 = Current-limit source resets the time base for this PWM generator if it is in Independent Time Base mode
0 = External pins do not affect PWM time base
- bit 0 **IUE**: Immediate Update Enable bit
1 = Updates to the active MDC/PDCx/SDCx registers are immediate
0 = Updates to the active PDCx registers are synchronized to the PWM time base

- Note 1:** Software must clear the interrupt status here and in the corresponding IFSx bit in the interrupt controller.
- 2:** The Independent Time Base mode (ITB = 1) must be enabled to use Center-Aligned mode. If ITB = 0, the CAM bit is ignored.
- 3:** These bits should not be changed after the PWM is enabled by setting PTEN (PTCON<15>) = 1.
- 4:** For DTCP to be effective, DTC<1:0> must be set to '11'; otherwise, DTCP is ignored.
- 5:** Center-Aligned mode ignores the Least Significant 3 bits of the Duty Cycle, Phase and Dead-Time registers. The highest Center-Aligned mode resolution available is 8.32 ns with the clock prescaler set to the fastest clock.
- 6:** Configure CLMOD (FCLCONX<8>) = 0 and ITB (PWMCONx<9>) = 1 to operate in External Period Reset mode.

dsPIC33FJ32GS406/606/608/610 and dsPIC33FJ64GS406/606/608/610

REGISTER 16-12: PDCx: PWM GENERATOR DUTY CYCLE x REGISTER^(1,2,3)

| | | | | | | | |
|------------|-------|-------|-------|-------|-------|-------|-------|
| R/W-0 | R/W-0 | R/W-0 | R/W-0 | R/W-0 | R/W-0 | R/W-0 | R/W-0 |
| PDCx<15:8> | | | | | | | |
| bit 15 | | | | bit 8 | | | |

| | | | | | | | |
|-----------|-------|-------|-------|-------|-------|-------|-------|
| R/W-0 | R/W-0 | R/W-0 | R/W-0 | R/W-0 | R/W-0 | R/W-0 | R/W-0 |
| PDCx<7:0> | | | | | | | |
| bit 7 | | | | bit 0 | | | |

Legend:

| | | |
|-------------------|------------------|------------------------------------|
| R = Readable bit | W = Writable bit | U = Unimplemented bit, read as '0' |
| -n = Value at POR | '1' = Bit is set | '0' = Bit is cleared |
| | | x = Bit is unknown |

bit 15-0 **PDCx<15:0>**: PWM Generator # Duty Cycle Value bits

- Note 1:** In Independent PWM mode, the PDCx register controls the PWMxH duty cycle only. In the Complementary, Redundant and Push-Pull PWM modes, the PDCx register controls the duty cycle of both the PWMxH and PWMxL.
- 2:** The smallest pulse width that can be generated on the PWM output corresponds to a value of 0x0008, while the maximum pulse width generated corresponds to a value of Period – 0x0008.
- 3:** As the duty cycle gets closer to 0% or 100% of the PWM period (0 to 40 ns, depending on the mode of operation), PWM duty cycle resolution will increase from 1 to 3 LSBs.

REGISTER 16-13: SDCx: PWM SECONDARY DUTY CYCLE x REGISTER^(1,2,3)

| | | | | | | | |
|------------|-------|-------|-------|-------|-------|-------|-------|
| R/W-0 | R/W-0 | R/W-0 | R/W-0 | R/W-0 | R/W-0 | R/W-0 | R/W-0 |
| SDCx<15:8> | | | | | | | |
| bit 15 | | | | bit 8 | | | |

| | | | | | | | |
|-----------|-------|-------|-------|-------|-------|-------|-------|
| R/W-0 | R/W-0 | R/W-0 | R/W-0 | R/W-0 | R/W-0 | R/W-0 | R/W-0 |
| SDCx<7:0> | | | | | | | |
| bit 7 | | | | bit 0 | | | |

Legend:

| | | |
|-------------------|------------------|------------------------------------|
| R = Readable bit | W = Writable bit | U = Unimplemented bit, read as '0' |
| -n = Value at POR | '1' = Bit is set | '0' = Bit is cleared |
| | | x = Bit is unknown |

bit 15-0 **SDCx<15:0>**: Secondary Duty Cycle bits for PWMxL Output Pin

- Note 1:** The SDCx register is used in Independent PWM mode only. When used in Independent PWM mode, the SDCx register controls the PWMxL duty cycle.
- 2:** The smallest pulse width that can be generated on the PWM output corresponds to a value of 0x0008, while the maximum pulse width generated corresponds to a value of Period – 0x0008.
- 3:** As the duty cycle gets closer to 0% or 100% of the PWM period (0 to 40 ns, depending on the mode of operation), PWM duty cycle resolution will increase from 1 to 3 LSBs.

dsPIC33FJ32GS406/606/608/610 and dsPIC33FJ64GS406/606/608/610

REGISTER 16-14: PHASEx: PWM PRIMARY PHASE SHIFT x REGISTER^(1,2)

| | | | | | | | |
|--------------|-------|-------|-------|-------|-------|-------|-------|
| R/W-0 | R/W-0 | R/W-0 | R/W-0 | R/W-0 | R/W-0 | R/W-0 | R/W-0 |
| PHASEx<15:8> | | | | | | | |
| bit 15 | | | | | | | bit 8 |

| | | | | | | | |
|-------------|-------|-------|-------|-------|-------|-------|-------|
| R/W-0 | R/W-0 | R/W-0 | R/W-0 | R/W-0 | R/W-0 | R/W-0 | R/W-0 |
| PHASEx<7:0> | | | | | | | |
| bit 7 | | | | | | | bit 0 |

Legend:

R = Readable bit

W = Writable bit

U = Unimplemented bit, read as '0'

-n = Value at POR

'1' = Bit is set

'0' = Bit is cleared

x = Bit is unknown

bit 15-0 **PHASEx<15:0>**: PWM Phase Shift Value or Independent Time Base Period for the PWM Generator bits

Note 1: If PWMCONx<9> = 0, the following applies based on the mode of operation:

- Complementary, Redundant and Push-Pull Output mode (IOCONx<10:8> = 00, 01 or 10), PHASEx<15:0> = Phase Shift Value for PWMxH and PWMxL outputs.
- True Independent Output mode (IOCONx<10:8> = 11), PHASEx<15:0> = Phase Shift Value for PWMxH only.
- The PHASEx/SPHASEx registers provide the phase shift with respect to the master time base; therefore, the valid range is 0x0000 through period.

2: If PWMCONx<9> = 1, the following applies based on the mode of operation:

- Complementary, Redundant and Push-Pull Output mode (IOCONx<10:8> = 00, 01 or 10), PHASEx<15:0> = Independent Time Base Period Value for PWMxH and PWMxL.
- True Independent Output mode (IOCONx<10:8> = 11). PHASEx<15:0> = Independent Time Base Period Value for PWMxH only.
- When the PHASEx/SPHASEx registers provide the local period, the valid range is 0x0000 through 0xFF8.

REGISTER 16-15: SPHASE_x: PWM SECONDARY PHASE SHIFT x REGISTER^(1,2)

| | | | | | | | |
|----------------------------|-------|-------|-------|-------|-------|-------|-------|
| R/W-0 | R/W-0 | R/W-0 | R/W-0 | R/W-0 | R/W-0 | R/W-0 | R/W-0 |
| SPHASE _x <15:8> | | | | | | | |
| bit 15 | | | | bit 8 | | | |

| | | | | | | | |
|---------------------------|-------|-------|-------|-------|-------|-------|-------|
| R/W-0 | R/W-0 | R/W-0 | R/W-0 | R/W-0 | R/W-0 | R/W-0 | R/W-0 |
| SPHASE _x <7:0> | | | | | | | |
| bit 7 | | | | bit 0 | | | |

Legend:

| | | |
|-------------------|------------------|--|
| R = Readable bit | W = Writable bit | U = Unimplemented bit, read as '0' |
| -n = Value at POR | '1' = Bit is set | '0' = Bit is cleared x = Bit is unknown |

bit 15-0 **SPHASE_x<15:0>**: Secondary Phase Offset bits for PWM_xL Output Pin bits (used in Independent PWM mode only)

Note 1: If PWMCON_x<9> = 0, the following applies based on the mode of operation:

- Complementary, Redundant and Push-Pull Output mode (IOCON_x<10:8> = 00, 01 or 10), SPHASE_x<15:0> = Not Used.
- True Independent Output mode (IOCON_x<10:8> = 11), PHASE_x<15:0> = Phase Shift Value for PWM_xL only.
- The PHASE_x/SPHASE_x registers provide the phase shift with respect to the master time base; therefore, the valid range is 0x0000 through period.

2: If PWMCON_x<9> = 1, the following applies based on the mode of operation:

- Complementary, Redundant and Push-Pull Output mode (IOCON_x<10:8> = 00, 01 or 10), SPHASE_x<15:0> = Not Used.
- True Independent Output mode (IOCON_x<10:8> = 11). PHASE_x<15:0> = Independent Time Base Period Value for PWM_xL only.
- When the PHASE_x/SPHASE_x registers provide the local period, the valid range of values is 0x0010-0xFFFF8.

dsPIC33FJ32GS406/606/608/610 and dsPIC33FJ64GS406/606/608/610

REGISTER 16-16: DTRx: PWM DEAD-TIME x REGISTER

| | | | | | | | |
|--------|-----|------------|-------|-------|-------|-------|-------|
| U-0 | U-0 | R/W-0 | R/W-0 | R/W-0 | R/W-0 | R/W-0 | R/W-0 |
| — | — | DTRx<13:8> | | | | | |
| bit 15 | | | | | | | bit 8 |

| | | | | | | | |
|-----------|-------|-------|-------|-------|-------|-------|-------|
| R/W-0 | R/W-0 | R/W-0 | R/W-0 | R/W-0 | R/W-0 | R/W-0 | R/W-0 |
| DTRx<7:0> | | | | | | | |
| bit 7 | | | | | | | bit 0 |

Legend:

R = Readable bit W = Writable bit U = Unimplemented bit, read as '0'
 -n = Value at POR '1' = Bit is set '0' = Bit is cleared x = Bit is unknown

bit 15-14 **Unimplemented:** Read as '0'
 bit 13-0 **DTRx<13:0>:** Unsigned 14-Bit Value for PWMx Dead-Time Unit bits

REGISTER 16-17: ALTDTRx: PWM ALTERNATE DEAD-TIME x REGISTER

| | | | | | | | |
|--------|-----|---------------|-------|-------|-------|-------|-------|
| U-0 | U-0 | R/W-0 | R/W-0 | R/W-0 | R/W-0 | R/W-0 | R/W-0 |
| — | — | ALTDTRx<13:8> | | | | | |
| bit 15 | | | | | | | bit 8 |

| | | | | | | | |
|--------------|-------|-------|-------|-------|-------|-------|-------|
| R/W-0 | R/W-0 | R/W-0 | R/W-0 | R/W-0 | R/W-0 | R/W-0 | R/W-0 |
| ALTDTRx<7:0> | | | | | | | |
| bit 7 | | | | | | | bit 0 |

Legend:

R = Readable bit W = Writable bit U = Unimplemented bit, read as '0'
 -n = Value at POR '1' = Bit is set '0' = Bit is cleared x = Bit is unknown

bit 15-14 **Unimplemented:** Read as '0'
 bit 13-0 **ALTDTRx<13:0>:** Unsigned 14-Bit Value for PWMx Dead-Time Unit bits

REGISTER 16-18: TRGCONx: PWM TRIGGER CONTROL x REGISTER

| | | | | | | | |
|-------------|-------|-------|-------|-------|-----|-----|-----|
| R/W-0 | R/W-0 | R/W-0 | R/W-0 | U-0 | U-0 | U-0 | U-0 |
| TRGDIV<3:0> | | | | — | — | — | — |
| bit 15 | | | | bit 8 | | | |

| | | | | | | | |
|--------------------|-----|--------------|-------|-------|-------|-------|-------|
| R/W-0 | U-0 | R/W-0 | R/W-0 | R/W-0 | R/W-0 | R/W-0 | R/W-0 |
| DTM ⁽¹⁾ | — | TRGSTRT<5:0> | | | | | |
| bit 7 | | bit 0 | | | | | |

Legend:

| | | |
|-------------------|------------------|------------------------------------|
| R = Readable bit | W = Writable bit | U = Unimplemented bit, read as '0' |
| -n = Value at POR | '1' = Bit is set | '0' = Bit is cleared |
| | | x = Bit is unknown |

bit 15-12 **TRGDIV<3:0>**: Trigger # Output Divider bits

1111 = Trigger output for every 16th trigger event
 1110 = Trigger output for every 15th trigger event
 1101 = Trigger output for every 14th trigger event
 1100 = Trigger output for every 13th trigger event
 1011 = Trigger output for every 12th trigger event
 1010 = Trigger output for every 11th trigger event
 1001 = Trigger output for every 10th trigger event
 1000 = Trigger output for every 9th trigger event
 0111 = Trigger output for every 8th trigger event
 0110 = Trigger output for every 7th trigger event
 0101 = Trigger output for every 6th trigger event
 0100 = Trigger output for every 5th trigger event
 0011 = Trigger output for every 4th trigger event
 0010 = Trigger output for every 3rd trigger event
 0001 = Trigger output for every 2nd trigger event
 0000 = Trigger output for every trigger event

bit 11-8 **Unimplemented**: Read as '0'

bit 7 **DTM**: Dual Trigger Mode bit⁽¹⁾

1 = Secondary trigger event is combined with the primary trigger event to create the PWM trigger
 0 = Secondary trigger event is not combined with the primary trigger event to create the PWM trigger;
 two separate PWM triggers are generated

bit 6 **Unimplemented**: Read as '0'

bit 5-0 **TRGSTRT<5:0>**: Trigger Postscaler Start Enable Select bits

111111 = Waits 63 PWM cycles before generating the first trigger event after the module is enabled
 •
 •
 •
 000010 = Waits 2 PWM cycles before generating the first trigger event after the module is enabled
 000001 = Waits 1 PWM cycle before generating the first trigger event after the module is enabled
 000000 = Waits 0 PWM cycles before generating the first trigger event after the module is enabled

Note 1: The secondary PWM generator cannot generate PWM trigger interrupts.

dsPIC33FJ32GS406/606/608/610 and dsPIC33FJ64GS406/606/608/610

REGISTER 16-19: IOCONx: PWM I/O CONTROL x REGISTER

| | | | | | | | |
|--------|-------|-------|-------|--------------------------|-------|--------|--------|
| R/W-0 | R/W-0 | R/W-0 | R/W-0 | R/W-0 | R/W-0 | R/W-0 | R/W-0 |
| PENH | PENL | POLH | POLL | PMOD<1:0> ⁽¹⁾ | | OVRENH | OVRENL |
| bit 15 | | | | | | bit 8 | |

| | | | | | | | |
|-------------|-------|----------------------------|-------|---------------------------|-------|-------|-------|
| R/W-0 | R/W-0 | R/W-0 | R/W-0 | R/W-0 | R/W-0 | R/W-0 | R/W-0 |
| OVRDAT<1:0> | | FLTDAT<1:0> ⁽²⁾ | | CLDAT<1:0> ⁽²⁾ | | SWAP | OSYNC |
| bit 7 | | | | | | bit 0 | |

Legend:

| | | |
|-------------------|------------------|------------------------------------|
| R = Readable bit | W = Writable bit | U = Unimplemented bit, read as '0' |
| -n = Value at POR | '1' = Bit is set | '0' = Bit is cleared |
| | | x = Bit is unknown |

- bit 15 **PENH:** PWMxH Output Pin Ownership bit
 1 = PWM module controls PWMxH pin
 0 = GPIO module controls PWMxH pin
- bit 14 **PENL:** PWMxL Output Pin Ownership bit
 1 = PWM module controls PWMxL pin
 0 = GPIO module controls PWMxL pin
- bit 13 **POLH:** PWMxH Output Pin Polarity bit
 1 = PWMxH pin is active-low
 0 = PWMxH pin is active-high
- bit 12 **POLL:** PWMxL Output Pin Polarity bit
 1 = PWMxL pin is active-low
 0 = PWMxL pin is active-high
- bit 11-10 **PMOD<1:0>:** PWM # I/O Pin Mode bits⁽¹⁾
 11 = PWM I/O pin pair is in the True Independent Output mode
 10 = PWM I/O pin pair is in the Push-Pull Output mode
 01 = PWM I/O pin pair is in the Redundant Output mode
 00 = PWM I/O pin pair is in the Complementary Output mode
- bit 9 **OVRENH:** Override Enable for PWMxH Pin bit
 1 = OVRDAT<1> provides data for output on PWMxH pin
 0 = PWM generator provides data for output on PWMxH pin
- bit 8 **OVRENL:** Override Enable for PWMxL Pin bit
 1 = OVRDAT<0> provides data for output on PWMxL pin
 0 = PWM generator provides data for output on PWMxL pin
- bit 7-6 **OVRDAT<1:0>:** Data for PWMxH, PWMxL Pins if Override is Enabled bits
 If OVERENH = 1, OVRDAT<1> provides data for PWMxH
 If OVERENL = 1, OVRDAT<0> provides data for PWMxL
- bit 5-4 **FLTDAT<1:0>:** State for PWMxH and PWMxL Pins if FLTMOD is Enabled bits⁽²⁾
IFLTMOD (FCLCONx<15>) = 0: Normal Fault mode:
 If Fault is active, then FLTDAT<1> provides the state for PWMxH.
 If Fault is active, then FLTDAT<0> provides the state for PWMxL.
IFLTMOD (FCLCONx<15>) = 1: Independent Fault mode:
 If current-limit is active, then FLTDAT<1> provides the state for PWMxH.
 If Fault is active, then FLTDAT<0> provides the state for PWMxL.

Note 1: These bits should not be changed after the PWM module is enabled (PTEN = 1).

2: State represents the active/inactive state of the PWM depending on the POLH and POLL bit settings.

REGISTER 16-19: IOCONx: PWM I/O CONTROL x REGISTER (CONTINUED)

- bit 3-2 **CLDAT<1:0>**: State for PWMxH and PWMxL Pins if CLMOD is Enabled bits⁽²⁾
IFLTMOD (FCLCONx<15>) = 0: Normal Fault mode:
 If current-limit is active, then CLDAT<1> provides the state for PWMxH.
 If current-limit is active, then CLDAT<0> provides the state for PWMxL.
IFLTMOD (FCLCONx<15>) = 1: Independent Fault mode:
 CLDAT<1:0> is ignored.
- bit 1 **SWAP**: SWAP PWMxH and PWMxL Pins bit
 1 = PWMxH output signal is connected to the PWMxL pin; PWMxL output signal is connected to the PWMxH pin
 0 = PWMxH and PWMxL pins are mapped to their respective pins
- bit 0 **OSYNC**: Output Override Synchronization bit
 1 = Output overrides, via the OVRDAT<1:0> bits, are synchronized to the PWM time base
 0 = Output overrides, via the OVDDAT<1:0> bits, occur on next CPU clock boundary

- Note 1:** These bits should not be changed after the PWM module is enabled (PTEN = 1).
2: State represents the active/inactive state of the PWM depending on the POLH and POLL bit settings.

REGISTER 16-20: TRIGx: PWM PRIMARY TRIGGER x COMPARE VALUE REGISTER

| | | | | | | | |
|--------------|-------|-------|-------|-------|-------|-------|-------|
| R/W-0 | R/W-0 | R/W-0 | R/W-0 | R/W-0 | R/W-0 | R/W-0 | R/W-0 |
| TRGCMP<15:8> | | | | | | | |
| bit 15 | | | | bit 8 | | | |

| | | | | | | | |
|-------------|-------|-------|-------|-------|-----|-----|-----|
| R/W-0 | R/W-0 | R/W-0 | R/W-0 | R/W-0 | U-0 | U-0 | U-0 |
| TRGCMP<7:3> | | | | | — | — | — |
| bit 7 | | | | bit 0 | | | |

| | | | |
|-------------------|------------------|------------------------------------|--------------------|
| Legend: | | | |
| R = Readable bit | W = Writable bit | U = Unimplemented bit, read as '0' | |
| -n = Value at POR | '1' = Bit is set | '0' = Bit is cleared | x = Bit is unknown |

- bit 15-3 **TRGCMP<15:3>**: Trigger Compare Value bits
 When the primary PWM functions in the local time base, this register contains the compare values that can trigger the ADC module.
- bit 2-0 **Unimplemented**: Read as '0'

dsPIC33FJ32GS406/606/608/610 and dsPIC33FJ64GS406/606/608/610

REGISTER 16-21: FCLCONx: PWM FAULT CURRENT-LIMIT CONTROL x REGISTER

| | | | | | | | |
|---------|-----------------------------|-------|-------|-------|-------|----------------------|-------|
| R/W-0 | R/W-0 | R/W-0 | R/W-0 | R/W-0 | R/W-0 | R/W-0 | R/W-0 |
| IFLTMOD | CLSRC<4:0> ^(2,3) | | | | | CLPOL ⁽¹⁾ | CLMOD |
| bit 15 | | | | | | bit 8 | |

| | | | | | | | |
|------------------------------|-------|-------|-------|-------|-----------------------|-------------|-------|
| R/W-0 | R/W-0 | R/W-0 | R/W-0 | R/W-0 | R/W-0 | R/W-0 | R/W-0 |
| FLTSRC<4:0> ^(2,3) | | | | | FLTPOL ⁽¹⁾ | FLTMOD<1:0> | |
| bit 7 | | | | | | bit 0 | |

Legend:

R = Readable bit W = Writable bit U = Unimplemented bit, read as '0'
 -n = Value at POR '1' = Bit is set '0' = Bit is cleared x = Bit is unknown

bit 15 **IFLTMOD:** Independent Fault Mode Enable bit
 1 = Independent Fault mode: Current-limit input maps FLTDAT<1> to PWMxH output and Fault input maps FLTDAT<0> to PWMxL output. The CLDAT<1:0> bits are not used for override functions.
 0 = Normal Fault mode: Current-Limit mode maps CLDAT<1:0> bits to the PWMxH and PWMxL outputs. The PWM Fault mode maps FLTDAT<1:0> to the PWMxH and PWMxL outputs.

bit 14-10 **CLSRC<4:0>:** Current-Limit Control Signal Source Select for PWM Generator # bits^(2,3)
 These bits also specify the source for the Dead-Time Compensation input signal, DTCMPx.

- 11111 = Reserved
- 11110 = Fault 23
- 11101 = Fault 22
- 11100 = Fault 21
- 11011 = Fault 20
- 11010 = Fault 19
- 11001 = Fault 18
- 11000 = Fault 17
- 10111 = Fault 16
- 10110 = Fault 15
- 10101 = Fault 14
- 10100 = Fault 13
- 10011 = Fault 12
- 10010 = Fault 11
- 10001 = Fault 10
- 10000 = Fault 9
- 01111 = Fault 8
- 01110 = Fault 7
- 01101 = Fault 6
- 01100 = Fault 5
- 01011 = Fault 4
- 01010 = Fault 3
- 01001 = Fault 2
- 01000 = Fault 1
- 00111 = Reserved
- 00110 = Reserved
- 00101 = Reserved
- 00100 = Reserved
- 00011 = Analog Comparator 4
- 00010 = Analog Comparator 3
- 00001 = Analog Comparator 2
- 00000 = Analog Comparator 1

- Note 1:** These bits should be changed only when PTEN (PTCON<15>) = 0.
- 2:** When Independent Fault mode is enabled (IFLTMOD = 1) and Fault 1 is used for Current-Limit mode (CLSRC<4:0> = b0000), the Fault Control Source Select bits (FLTSRC<4:0>) should be set to an unused Fault source to prevent Fault 1 from disabling both the PWMxL and PWMxH outputs.
- 3:** When Independent Fault mode is enabled (IFLTMOD = 1) and Fault 1 is used for Fault mode (FLTSRC<4:0> = b0000), the Current-Limit Control Source Select bits (CLSRC<4:0>) should be set to an unused current-limit source to prevent the current-limit source from disabling both the PWMxH and PWMxL outputs.

REGISTER 16-21: FCLCONx: PWM FAULT CURRENT-LIMIT CONTROL x REGISTER (CONTINUED)

| | |
|---------|---|
| bit 9 | CLPOL: Current-Limit Polarity for PWM Generator # bit ⁽¹⁾ 1 = The selected current-limit source is active-low 0 = The selected current-limit source is active-high |
| bit 8 | CLMOD: Current-Limit Mode Enable for PWM Generator # bit 1 = Current-Limit mode is enabled 0 = Current-Limit mode is disabled |
| bit 7-3 | FLTSRC<4:0>: Fault Control Signal Source Select for PWM Generator # bits ^(2,3) 11111 = Reserved 11110 = Fault 23 11101 = Fault 22 11100 = Fault 21 11011 = Fault 20 11010 = Fault 19 11001 = Fault 18 11000 = Fault 17 10111 = Fault 16 10110 = Fault 15 10101 = Fault 14 10100 = Fault 13 10011 = Fault 12 10010 = Fault 11 10001 = Fault 10 10000 = Fault 9 01111 = Fault 8 01110 = Fault 7 01101 = Fault 6 01100 = Fault 5 01011 = Fault 4 01010 = Fault 3 01001 = Fault 2 01000 = Fault 1 00111 = Reserved 00110 = Reserved 00101 = Reserved 00100 = Reserved 00011 = Analog Comparator 4 00010 = Analog Comparator 3 00001 = Analog Comparator 2 00000 = Analog Comparator 1 |
| bit 2 | FLTPOL: Fault Polarity for PWM Generator # bit ⁽¹⁾ 1 = The selected Fault source is active-low 0 = The selected Fault source is active-high |
| bit 1-0 | FLTMOD<1:0>: Fault Mode for PWM Generator # bits 11 = Fault input is disabled 10 = Reserved 01 = The selected Fault source forces PWMxH, PWMxL pins to FLTDAT values (cycle) 00 = The selected Fault source forces PWMxH, PWMxL pins to FLTDAT values (latched condition) |

Note 1: These bits should be changed only when PTEN (PTCON<15>) = 0.

2: When Independent Fault mode is enabled (IFLTMOD = 1) and Fault 1 is used for Current-Limit mode (CLSRC<4:0> = b0000), the Fault Control Source Select bits (FLTSRC<4:0>) should be set to an unused Fault source to prevent Fault 1 from disabling both the PWMxL and PWMxH outputs.

3: When Independent Fault mode is enabled (IFLTMOD = 1) and Fault 1 is used for Fault mode (FLTSRC<4:0> = b0000), the Current-Limit Control Source Select bits (CLSRC<4:0>) should be set to an unused current-limit source to prevent the current-limit source from disabling both the PWMxH and PWMxL outputs.

dsPIC33FJ32GS406/606/608/610 and dsPIC33FJ64GS406/606/608/610

REGISTER 16-22: STRIGx: PWM SECONDARY TRIGGER x COMPARE VALUE REGISTER⁽¹⁾

| | | | | | | | |
|---------------|-------|-------|-------|-------|-------|-------|-------|
| R/W-0 | R/W-0 | R/W-0 | R/W-0 | R/W-0 | R/W-0 | R/W-0 | R/W-0 |
| STRGCMP<15:8> | | | | | | | |
| bit 15 | | | | | | | bit 8 |

| | | | | | | | |
|--------------|-------|-------|-------|-------|-----|-----|-------|
| R/W-0 | R/W-0 | R/W-0 | R/W-0 | R/W-0 | U-0 | U-0 | U-0 |
| STRGCMP<7:3> | | | | | — | — | — |
| bit 7 | | | | | | | bit 0 |

Legend:

R = Readable bit

W = Writable bit

U = Unimplemented bit, read as '0'

-n = Value at POR

'1' = Bit is set

'0' = Bit is cleared

x = Bit is unknown

bit 15-3 **STRGCMP<15:3>**: PWM Secondary Trigger Compare Value bits

When the secondary PWM functions in a local time base, this register contains the compare values that can trigger the ADC module.

bit 2-0 **Unimplemented**: Read as '0'

Note 1: STRIGx cannot generate the PWM trigger interrupts.

dsPIC33FJ32GS406/606/608/610 and dsPIC33FJ64GS406/606/608/610

REGISTER 16-23: LEBCONx: LEADING-EDGE BLANKING CONTROL x REGISTER

| | | | | | | | |
|--------|-------|--------------------|--------------------|----------|---------|-------|-------|
| R/W-0 | R/W-0 | R/W-0 | R/W-0 | R/W-0 | R/W-0 | U-0 | U-0 |
| PHR | PHF | PLR | PLF | FLTLEBEN | CLLEBEN | — | — |
| bit 15 | | | | | | bit 8 | |
| U-0 | U-0 | R/W-0 | R/W-0 | R/W-0 | R/W-0 | R/W-0 | R/W-0 |
| — | — | BCH ⁽¹⁾ | BCL ⁽¹⁾ | BPHH | BPHL | BPLH | BPLL |
| bit 7 | | | | | | bit 0 | |

Legend:

| | | |
|-------------------|------------------|------------------------------------|
| R = Readable bit | W = Writable bit | U = Unimplemented bit, read as '0' |
| -n = Value at POR | '1' = Bit is set | '0' = Bit is cleared |
| | | x = Bit is unknown |

- bit 15 **PHR:** PWMxH Rising Edge Trigger Enable bit
 1 = Rising edge of PWMxH will trigger Leading-Edge Blanking counter
 0 = Leading-Edge Blanking ignores rising edge of PWMxH
- bit 14 **PHF:** PWMxH Falling Edge Trigger Enable bit
 1 = Falling edge of PWMxH will trigger Leading-Edge Blanking counter
 0 = Leading-Edge Blanking ignores falling edge of PWMxH
- bit 13 **PLR:** PWMxL Rising Edge Trigger Enable bit
 1 = Rising edge of PWMxL will trigger Leading-Edge Blanking counter
 0 = Leading-Edge Blanking ignores rising edge of PWMxL
- bit 12 **PLF:** PWMxL Falling Edge Trigger Enable bit
 1 = Falling edge of PWMxL will trigger Leading-Edge Blanking counter
 0 = Leading-Edge Blanking ignores falling edge of PWMxL
- bit 11 **FLTLEBEN:** Fault Input Leading-Edge Blanking Enable bit
 1 = Leading-Edge Blanking is applied to selected Fault input
 0 = Leading-Edge Blanking is not applied to selected Fault input
- bit 10 **CLLEBEN:** Current-Limit Leading-Edge Blanking Enable bit
 1 = Leading-Edge Blanking is applied to selected current-limit input
 0 = Leading-Edge Blanking is not applied to selected current-limit input
- bit 9-6 **Unimplemented:** Read as '0'
- bit 5 **BCH:** Blanking in Selected Blanking Signal High Enable bit⁽¹⁾
 1 = State blanking (of current-limit and/or Fault input signals) when selected blanking signal is high
 0 = No blanking when selected blanking signal is high
- bit 4 **BCL:** Blanking in Selected Blanking Signal Low Enable bit⁽¹⁾
 1 = State blanking (of current-limit and/or Fault input signals) when selected blanking signal is low
 0 = No blanking when selected blanking signal is low
- bit 3 **BPHH:** Blanking in PWMxH High Enable bit
 1 = State blanking (of current-limit and/or Fault input signals) when PWMxH output is high
 0 = No blanking when PWMxH output is high
- bit 2 **BPHL:** Blanking in PWMxH Low Enable bit
 1 = State blanking (of current-limit and/or Fault input signals) when PWMxH output is low
 0 = No blanking when PWMxH output is low
- bit 1 **BPLH:** Blanking in PWMxL High Enable bit
 1 = State blanking (of current-limit and/or Fault input signals) when PWMxL output is high
 0 = No blanking when PWMxL output is high
- bit 0 **BPLL:** Blanking in PWMxL Low Enable bit
 1 = State blanking (of current-limit and/or Fault input signals) when PWMxL output is low
 0 = No blanking when PWMxL output is low

Note 1: The blanking signal is selected via the BLANKSELx bits in the AUXCONx register.

dsPIC33FJ32GS406/606/608/610 and dsPIC33FJ64GS406/606/608/610

REGISTER 16-24: LEBDLYx: LEADING-EDGE BLANKING DELAY x REGISTER

| | | | | | | | |
|--------|-----|-----|-----|-----------|-------|-------|-------|
| U-0 | U-0 | U-0 | U-0 | R/W-0 | R/W-0 | R/W-0 | R/W-0 |
| — | — | — | — | LEB<11:8> | | | |
| bit 15 | | | | bit 8 | | | |

| | | | | | | | |
|----------|-------|-------|-------|-------|-----|-------|-----|
| R/W-0 | R/W-0 | R/W-0 | R/W-0 | R/W-0 | U-0 | U-0 | U-0 |
| LEB<7:3> | | | | | — | — | — |
| bit 7 | | | | | | bit 0 | |

Legend:

R = Readable bit

W = Writable bit

U = Unimplemented bit, read as '0'

-n = Value at POR

'1' = Bit is set

'0' = Bit is cleared

x = Bit is unknown

bit 15-12 **Unimplemented:** Read as '0'

bit 11-3 **LEB<11:3>:** Leading-Edge Blanking Delay for Current-Limit and Fault Inputs bits

The value is in 8.32 ns increments.

bit 2-0 **Unimplemented:** Read as '0'

dsPIC33FJ32GS406/606/608/610 and dsPIC33FJ64GS406/606/608/610

REGISTER 16-25: AUXCONx: PWM AUXILIARY CONTROL x REGISTER

| | | | | | | | |
|--------|--------|--------------|-------|---------------|-------|---------|---------|
| R/W-0 | R/W-0 | U-0 | U-0 | R/W-0 | R/W-0 | R/W-0 | R/W-0 |
| HRPDIS | HRDDIS | — | — | BLANKSEL<3:0> | | | |
| bit 15 | | | | | | | bit 8 |
| U-0 | U-0 | R/W-0 | R/W-0 | R/W-0 | R/W-0 | R/W-0 | R/W-0 |
| — | — | CHOPSEL<3:0> | | | | CHOPHEN | CHOPLEN |
| bit 7 | | | | | | | bit 0 |

Legend:

R = Readable bit W = Writable bit U = Unimplemented bit, read as '0'
-n = Value at POR '1' = Bit is set '0' = Bit is cleared x = Bit is unknown

- bit 15 **HRPDIS:** High-Resolution PWM Period Disable bit
1 = High-resolution PWM period is disabled to reduce power consumption
0 = High-resolution PWM period is enabled
- bit 14 **HRDDIS:** High-Resolution PWM Duty Cycle Disable bit
1 = High-resolution PWM duty cycle is disabled to reduce power consumption
0 = High-resolution PWM duty cycle is enabled
- bit 13-12 **Unimplemented:** Read as '0'
- bit 11-8 **BLANKSEL<3:0>:** PWM State Blank Source Select bits
The selected state blank signal will block the current limit and/or Fault input signals (if enabled via the BCH and BCL bits in the LEBCONx register).
1001 = PWM9H is selected as state blank source
1000 = PWM8H is selected as state blank source
0111 = PWM7H is selected as state blank source
0110 = PWM6H is selected as state blank source
0101 = PWM5H is selected as state blank source
0100 = PWM4H is selected as state blank source
0011 = PWM3H is selected as state blank source
0010 = PWM2H is selected as state blank source
0001 = PWM1H is selected as state blank source
0000 = 1'b0 (no state blanking)
- bit 7-6 **Unimplemented:** Read as '0'
- bit 5-2 **CHOPSEL<3:0>:** PWM Chop Clock Source Select bits
The selected signal will enable and disable (CHOPx) the selected PWM outputs.
1001 = PWM9H is selected as chop clock source
1000 = PWM8H is selected as chop clock source
0111 = PWM7H is selected as chop clock source
0110 = PWM6H is selected as chop clock source
0101 = PWM5H is selected as chop clock source
0100 = PWM4H is selected as chop clock source
0011 = PWM3H is selected as chop clock source
0010 = PWM2H is selected as chop clock source
0001 = PWM1H is selected as chop clock source
0000 = Chop clock generator is selected as the chop clock source
- bit 1 **CHOPHEN:** PWMxH Output Chopping Enable bit
1 = PWMxH chopping function is enabled
0 = PWMxH chopping function is disabled
- bit 0 **CHOPLEN:** PWMxL Output Chopping Enable bit
1 = PWMxL chopping function is enabled
0 = PWMxL chopping function is disabled

dsPIC33FJ32GS406/606/608/610 and dsPIC33FJ64GS406/606/608/610

REGISTER 16-26: PWMCAPx: PRIMARY PWM TIME BASE CAPTURE x REGISTER

| | | | | | | | |
|-----------------------------------|-----|-----|-----|-----|-----|-----|-------|
| R-0 | R-0 | R-0 | R-0 | R-0 | R-0 | R-0 | R-0 |
| PWMCAP<15:8> ^(1,2,3,4) | | | | | | | |
| bit 15 | | | | | | | bit 8 |

| | | | | | | | |
|----------------------------------|-----|-----|-----|-----|-----|-----|-------|
| R-0 | R-0 | R-0 | R-0 | R-0 | U-0 | U-0 | U-0 |
| PWMCAP<7:3> ^(1,2,3,4) | | | | | — | — | — |
| bit 7 | | | | | | | bit 0 |

Legend:

| | | |
|-------------------|------------------|------------------------------------|
| R = Readable bit | W = Writable bit | U = Unimplemented bit, read as '0' |
| -n = Value at POR | '1' = Bit is set | '0' = Bit is cleared |
| | | x = Bit is unknown |

bit 15-3 **PWMCAP<15:3>**: Captured PWM Time Base Value bits^(1,2,3,4)
 The value in this register represents the captured PWM time base value when a leading edge is detected on the current-limit input.

bit 2-0 **Unimplemented**: Read as '0'

- Note 1:** The capture feature is only available on the primary output (PWMxH).
2: This feature is active only after LEB processing on the current-limit input signal is complete.
3: The minimum capture resolution is 8.32 ns.
4: This feature can be used when the XPRES bit (PWMCONx<1>) is set to '0'.

17.0 QUADRATURE ENCODER INTERFACE (QEI) MODULE

Note 1: This data sheet summarizes the features of the dsPIC33FJ32GS406/606/608/610 and dsPIC33FJ64GS406/606/608/610 families of devices. It is not intended to be a comprehensive reference source. To complement the information in this data sheet, refer to **Section 15. “Quadrature Encoder Interface (QEI)”** (DS70208) in the “dsPIC33F/PIC24H Family Reference Manual”, which is available from the Microchip web site (www.microchip.com).

2: Some registers and associated bits described in this section may not be available on all devices. Refer to **Section 4.0 “Memory Organization”** in this data sheet for device-specific register and bit information.

This chapter describes the Quadrature Encoder Interface (QEI) module and associated operational modes. The QEI module provides the interface to incremental encoders for obtaining mechanical position data.

The operational features of the QEI include:

- Three Input Channels for Two Phase Signals and Index Pulse
- 16-Bit Up/Down Position Counter
- Count Direction Status
- Position Measurement (x2 and x4) mode
- Programmable Digital Noise Filters on Inputs
- Alternate 16-Bit Timer/Counter mode
- Quadrature Encoder Interface Interrupts

These operating modes are determined by setting the appropriate bits, QEIM<2:0> in (QEIxCON<10:8>). **Figure 17-1** depicts the Quadrature Encoder Interface block diagram.

Note: An ‘x’ used in the names of pins, control/status bits and registers denotes a particular QEI module number (x = 1 or 2).

FIGURE 17-1: QUADRATURE ENCODER INTERFACE x BLOCK DIAGRAM (x = 1 OR 2)



dsPIC33FJ32GS406/606/608/610 and dsPIC33FJ64GS406/606/608/610

REGISTER 17-1: QEIXCON: QEIX CONTROL REGISTER (x = 1 or 2)

| | | | | | | | |
|-----------------------|-----|---------|-------|---------------------|-----------|-------|-------|
| R/W-0 | U-0 | R/W-0 | R-0 | R/W-0 | R/W-0 | R/W-0 | R/W-0 |
| CNTERR ⁽¹⁾ | — | QEISIDL | INDEX | UPDN ⁽²⁾ | QEIM<2:0> | | |
| bit 15 | | | | bit 8 | | | |

| | | | | | | | |
|-------|--------|--------|----------------------------|-----------------------|-------|-------------------------|-------|
| R/W-0 | R/W-0 | R/W-0 | R/W-0 | R/W-0 | R/W-0 | R/W-0 | R/W-0 |
| SWPAB | PCDOUT | TQGATE | TQCKPS<1:0> ⁽³⁾ | POSRES ⁽⁴⁾ | TQCS | UPDN_SRC ⁽⁵⁾ | |
| bit 7 | | | | | | bit 0 | |

Legend:

R = Readable bit W = Writable bit U = Unimplemented bit, read as '0'
 -n = Value at POR '1' = Bit is set '0' = Bit is cleared x = Bit is unknown

- bit 15 **CNTERR:** Count Error Status Flag bit⁽¹⁾
 1 = Position count error has occurred
 0 = No position count error has occurred
- bit 14 **Unimplemented:** Read as '0'
- bit 13 **QEISIDL:** QEIX Stop in Idle Mode bit
 1 = Discontinues module operation when device enters Idle mode
 0 = Continues module operation in Idle mode
- bit 12 **INDEX:** Index Pin State Status bit (read-only)
 1 = Index pin is high
 0 = Index pin is low
- bit 11 **UPDN:** Position Counter Direction Status bit⁽²⁾
 1 = Position counter direction is positive (+)
 0 = Position counter direction is negative (-)
- bit 10-8 **QEIM<2:0>:** Quadrature Encoder Interface Mode Select bits
 111 = Quadrature Encoder Interface is enabled (x4 mode) with the position counter reset by the match (MAXxCNT)
 110 = Quadrature Encoder Interface is enabled (x4 mode) with the Index Pulse Reset of the position counter
 101 = Quadrature Encoder Interface is enabled (x2 mode) with the position counter reset by the match (MAXxCNT)
 100 = Quadrature Encoder Interface is enabled (x2 mode) with the Index Pulse Reset of the position counter
 011 = Unused (module disabled)
 010 = Unused (module disabled)
 001 = Starts 16-bit timer
 000 = Quadrature Encoder Interface/timer off
- bit 7 **SWPAB:** Phase A and Phase B Input Swap Select bit
 1 = Phase A and Phase B inputs are swapped
 0 = Phase A and Phase B inputs are not swapped
- bit 6 **PCDOUT:** Position Counter Direction State Output Enable bit
 1 = Position counter direction status output is enabled (QEI logic controls state of I/O pin)
 0 = Position counter direction status output is disabled (normal I/O pin operation)

- Note 1:** CNTERR flag only applies when QEIM<2:0> = 110 or 100.
Note 2: Read-only bit when QEIM<2:0> = 1xx. Read/write bit when QEIM<2:0> = 001.
Note 3: Prescaler utilized for 16-Bit Timer mode only.
Note 4: This bit applies only when QEIM<2:0> = 100 or 110.
Note 5: When configured for QEI mode, this control bit is a 'don't care'.

REGISTER 17-1: QEIxCON: QEIx CONTROL REGISTER (x = 1 or 2) (CONTINUED)

| | |
|---------|--|
| bit 5 | TQGATE: Timer Gated Time Accumulation Enable bit 1 = Timer gated time accumulation is enabled 0 = Timer gated time accumulation is disabled |
| bit 4-3 | TQCKPS<1:0>: Timer Input Clock Prescale Select bits ⁽³⁾ 11 = 1:256 prescale value 10 = 1:64 prescale value 01 = 1:8 prescale value 00 = 1:1 prescale value |
| bit 2 | POSRES: Position Counter Reset Enable bit ⁽⁴⁾ 1 = Index pulse resets position counter 0 = Index pulse does not reset position counter |
| bit 1 | TQCS: Timer Clock Source Select bit 1 = External clock from pin, QEAx (on the rising edge) 0 = Internal clock (Tcy) |
| bit 0 | UPDN_SRC: Position Counter Direction Selection Control bit ⁽⁵⁾ 1 = QEBx pin state defines the position counter direction 0 = Control/status bit, UPDN (QEIxCON<11>), defines the timer counter (POSxCNT) direction |

- Note 1:** CNTERR flag only applies when QEIM<2:0> = 110 or 100.
2: Read-only bit when QEIM<2:0> = 1xx. Read/write bit when QEIM<2:0> = 001.
3: Prescaler utilized for 16-Bit Timer mode only.
4: This bit applies only when QEIM<2:0> = 100 or 110.
5: When configured for QEI mode, this control bit is a 'don't care'.

dsPIC33FJ32GS406/606/608/610 and dsPIC33FJ64GS406/606/608/610

REGISTER 17-2: DFLT_xCON: DIGITAL FILTER x CONTROL REGISTER

| | | | | | | | |
|--------|-----|-----|-----|-----|----------|-------|-------|
| U-0 | U-0 | U-0 | U-0 | U-0 | R/W-0 | R/W-0 | R/W-0 |
| — | — | — | — | — | IMV<2:0> | | CEID |
| bit 15 | | | | | | | bit 8 |

| | | | | | |
|-------|-----------|-----|-----|-----|-------|
| R/W-0 | R/W-0 | U-0 | U-0 | U-0 | U-0 |
| QEOUT | QECK<2:0> | — | — | — | — |
| bit 7 | | | | | bit 0 |

Legend:

R = Readable bit W = Writable bit U = Unimplemented bit, read as '0'
 -n = Value at POR '1' = Bit is set '0' = Bit is cleared x = Bit is unknown

- bit 15-11 **Unimplemented:** Read as '0'
- bit 10-9 **IMV<1:0>:** Index Match Value bits – These bits allow the user application to specify the state of the QEAx and QEBx input pins during an Index pulse when the POSxCNT register is to be reset.
In x4 Quadrature Count Mode:
 IMV1 = Required state of Phase B input signal for match on index pulse
 IMV0 = Required state of Phase A input signal for match on index pulse
In x4 Quadrature Count Mode:
 IMV1 = Selects phase input signal for index state match (0 = Phase A, 1 = Phase B)
 IMV0 = Required state of the selected phase input signal for match on index pulse
- bit 8 **CEID:** Count Error Interrupt Disable bit
 1 = Interrupts due to count errors are disabled
 0 = Interrupts due to count errors are enabled
- bit 7 **QEOUT:** QEAx/QEBx/INDXx Pin Digital Filter Output Enable bit
 1 = Digital filter outputs are enabled
 0 = Digital filter outputs are disabled (normal pin operation)
- bit 6-4 **QECK<2:0>:** QEAx/QEBx/INDXx Digital Filter Clock Divide Select Bits
 111 = 1:256 clock divide
 110 = 1:128 clock divide
 101 = 1:64 clock divide
 100 = 1:32 clock divide
 011 = 1:16 clock divide
 010 = 1:4 clock divide
 001 = 1:2 clock divide
 000 = 1:1 clock divide
- bit 3-0 **Unimplemented:** Read as '0'

18.0 SERIAL PERIPHERAL INTERFACE (SPI)

Note 1: This data sheet summarizes the features of the dsPIC33FJ32GS406/606/608/610 and dsPIC33FJ64GS406/606/608/610 families of devices. It is not intended to be a comprehensive reference source. To complement the information in this data sheet, refer to **Section 18. “Serial Peripheral Interface (SPI)”** (DS70206) in the “dsPIC33F/PIC24H Family Reference Manual”, which is available from the Microchip web site (www.microchip.com).

2: Some registers and associated bits described in this section may not be available on all devices. Refer to **Section 4.0 “Memory Organization”** in this data sheet for device-specific register and bit information.

The Serial Peripheral Interface (SPI) module is a synchronous serial interface useful for communicating with other peripheral or microcontroller devices. These peripheral devices can be serial EEPROMs, shift registers, display drivers, Analog-to-Digital Converters and so on. The SPI module is compatible with SPI and SIOP from Motorola®.

The SPI module consists of a 16-bit shift register, SPIxSR (where x = 1 or 2), used for shifting data in and out, and a buffer register, SPIxBUF. A control register, SPIxCON, configures the module. Additionally, a status register, SPIxSTAT, indicates status conditions.

The serial interface consists of these four pins:

- SDIx (Serial Data Input)
- SDOx (Serial Data Output)
- SCKx (Shift Clock Input Or Output)
- \overline{SSx} (Active-Low Slave Select)

In Master mode operation, SCK is a clock output; in Slave mode, it is a clock input.

FIGURE 18-1: SPI MODULE BLOCK DIAGRAM



dsPIC33FJ32GS406/606/608/610 and dsPIC33FJ64GS406/606/608/610

REGISTER 18-1: SPIxSTAT: SPIx STATUS AND CONTROL REGISTER

| | | | | | | | |
|--------|-----|---------|-----|-----|-----|-----|-------|
| R/W-0 | U-0 | R/W-0 | U-0 | U-0 | U-0 | U-0 | U-0 |
| SPIEN | — | SPISIDL | — | — | — | — | — |
| bit 15 | | | | | | | bit 8 |

| | | | | | | | |
|-------|--------|-----|-----|-----|-----|--------|--------|
| U-0 | R/C-0 | U-0 | U-0 | U-0 | U-0 | R-0 | R-0 |
| — | SPIROV | — | — | — | — | SPITBF | SPIRBF |
| bit 7 | | | | | | | bit 0 |

| | | | |
|-------------------|-------------------|------------------------------------|--------------------|
| Legend: | C = Clearable bit | | |
| R = Readable bit | W = Writable bit | U = Unimplemented bit, read as '0' | |
| -n = Value at POR | '1' = Bit is set | '0' = Bit is cleared | x = Bit is unknown |

- bit 15 **SPIEN:** SPIx Enable bit
1 = Enables module and configures SCKx, SDOx, SDIx and \overline{SSx} as serial port pins
0 = Disables module
- bit 14 **Unimplemented:** Read as '0'
- bit 13 **SPISIDL:** SPIx Stop in Idle Mode bit
1 = Discontinues module operation when device enters Idle mode
0 = Continues module operation in Idle mode
- bit 12-7 **Unimplemented:** Read as '0'
- bit 6 **SPIROV:** SPIx Receive Overflow Flag bit
1 = A new byte/word is completely received and discarded; the user software has not read the previous data in the SPIxBUF register
0 = No overflow has occurred
- bit 5-2 **Unimplemented:** Read as '0'
- bit 1 **SPITBF:** SPIx Transmit Buffer Full Status bit
1 = Transmit has not yet started, SPIxTXB is full
0 = Transmit has started, SPIxTXB is empty. Automatically set in hardware when CPU writes the SPIxBUF location, loading SPIxTXB. Automatically cleared in hardware when the SPIx module transfers data from SPIxTXB to SPIxSR.
- bit 0 **SPIRBF:** SPIx Receive Buffer Full Status bit
1 = Receive is complete, SPIxRXB is full
0 = Receive is not complete, SPIxRXB is empty. Automatically set in hardware when SPIx transfers data from SPIxSR to SPIxRXB. Automatically cleared in hardware when the core reads the SPIxBUF location, reading SPIxRXB.

dsPIC33FJ32GS406/606/608/610 and dsPIC33FJ64GS406/606/608/610

REGISTER 18-2: SPIxCON1: SPIx CONTROL REGISTER 1

| | | | | | | | |
|--------|-----|-----|--------|--------|--------|-------|--------------------|
| U-0 | U-0 | U-0 | R/W-0 | R/W-0 | R/W-0 | R/W-0 | R/W-0 |
| — | — | — | DISSCK | DISSDO | MODE16 | SMP | CKE ⁽¹⁾ |
| bit 15 | | | | | | | bit 8 |

| | | | | | | | |
|---------------------|-------|-------|--------------------------|-------|-------|--------------------------|-------|
| R/W-0 | R/W-0 | R/W-0 | R/W-0 | R/W-0 | R/W-0 | R/W-0 | R/W-0 |
| SSEN ⁽³⁾ | CKP | MSTEN | SPRE<2:0> ⁽²⁾ | | | PPRE<1:0> ⁽²⁾ | |
| bit 7 | | | | | | | bit 0 |

Legend:

R = Readable bit W = Writable bit U = Unimplemented bit, read as '0'
-n = Value at POR '1' = Bit is set '0' = Bit is cleared x = Bit is unknown

- bit 15-13 **Unimplemented:** Read as '0'
- bit 12 **DISSCK:** Disable SCKx Pin bit (SPI Master modes only)
1 = Internal SPI clock is disabled; pin functions as I/O
0 = Internal SPI clock is enabled
- bit 11 **DISSDO:** Disable SDOx Pin bit
1 = SDOx pin is not used by module; pin functions as I/O
0 = SDOx pin is controlled by the module
- bit 10 **MODE16:** Word/Byte Communication Select bit
1 = Communication is word-wide (16 bits)
0 = Communication is byte-wide (8 bits)
- bit 9 **SMP:** SPIx Data Input Sample Phase bit
Master mode:
1 = Input data sampled at end of data output time
0 = Input data sampled at middle of data output time
Slave mode:
SMP must be cleared when SPIx is used in Slave mode.
- bit 8 **CKE:** SPIx Clock Edge Select bit⁽¹⁾
1 = Serial output data changes on transition from active clock state to Idle clock state (see bit 6)
0 = Serial output data changes on transition from Idle clock state to active clock state (see bit 6)
- bit 7 **SSEN:** Slave Select Enable bit (Slave mode)⁽³⁾
1 = \overline{SSx} pin is used for Slave mode
0 = \overline{SSx} pin is not used by module; pin is controlled by port function
- bit 6 **CKP:** Clock Polarity Select bit
1 = Idle state for clock is a high level; active state is a low level
0 = Idle state for clock is a low level; active state is a high level
- bit 5 **MSTEN:** Master Mode Enable bit
1 = Master mode
0 = Slave mode

- Note 1:** The CKE bit is not used in the Framed SPI modes. Program this bit to '0' for the Framed SPI modes (FRMEN = 1).
- 2:** Do not set both primary and secondary prescalers to a value of 1:1.
- 3:** This bit must be cleared when FRMEN = 1.

REGISTER 18-2: SPIxCON1: SPIx CONTROL REGISTER 1 (CONTINUED)

bit 4-2 **SPRE<2:0>**: Secondary Prescale bits (Master mode)⁽²⁾

111 = Secondary prescale 1:1

110 = Secondary prescale 2:1

•

•

•

000 = Secondary prescale 8:1

bit 1-0 **PPRE<1:0>**: Primary Prescale bits (Master mode)⁽²⁾

11 = Primary prescale 1:1

10 = Primary prescale 4:1

01 = Primary prescale 16:1

00 = Primary prescale 64:1

Note 1: The CKE bit is not used in the Framed SPI modes. Program this bit to '0' for the Framed SPI modes (FRMEN = 1).

2: Do not set both primary and secondary prescalers to a value of 1:1.

3: This bit must be cleared when FRMEN = 1.

dsPIC33FJ32GS406/606/608/610 and dsPIC33FJ64GS406/606/608/610

REGISTER 18-3: SPIxCON2: SPIx CONTROL REGISTER 2

| | | | | | | | |
|--------|--------|--------|-----|-----|-----|--------|-------|
| R/W-0 | R/W-0 | R/W-0 | U-0 | U-0 | U-0 | U-0 | U-0 |
| FRMEN | SPIFSD | FRMPOL | — | — | — | — | — |
| bit 15 | | | | | | | bit 8 |
| U-0 | U-0 | U-0 | U-0 | U-0 | U-0 | R/W-0 | U-0 |
| — | — | — | — | — | — | FRMDLY | — |
| bit 7 | | | | | | | bit 0 |

| | | | |
|-------------------|------------------|------------------------------------|--------------------|
| Legend: | | | |
| R = Readable bit | W = Writable bit | U = Unimplemented bit, read as '0' | |
| -n = Value at POR | '1' = Bit is set | '0' = Bit is cleared | x = Bit is unknown |

- bit 15 **FRMEN:** Framed SPIx Support bit
 1 = Framed SPIx support is enabled (\overline{SSx} pin is used as Frame Sync pulse input/output)
 0 = Framed SPIx support disabled
- bit 14 **SPIFSD:** Frame Sync Pulse Direction Control bit
 1 = Frame Sync pulse input (slave)
 0 = Frame Sync pulse output (master)
- bit 13 **FRMPOL:** Frame Sync Pulse Polarity bit
 1 = Frame Sync pulse is active-high
 0 = Frame Sync pulse is active-low
- bit 12-2 **Unimplemented:** Read as '0'
- bit 1 **FRMDLY:** Frame Sync Pulse Edge Select bit
 1 = Frame Sync pulse coincides with first bit clock
 0 = Frame Sync pulse precedes first bit clock
- bit 0 **Unimplemented:** This bit must not be set to '1' by the user application

NOTES:

19.0 INTER-INTEGRATED CIRCUIT (I²C™)

Note 1: This data sheet summarizes the features of the dsPIC33FJ32GS406/606/608/610 and dsPIC33FJ64GS406/606/608/610 families of devices. It is not intended to be a comprehensive reference source. To complement the information in this data sheet, refer to **Section 19. “Inter-Integrated Circuit (I²C™)”** (DS70195) in the “dsPIC33F/PIC24H Family Reference Manual”, which is available from the Microchip web site (www.microchip.com).

2: Some registers and associated bits described in this section may not be available on all devices. Refer to **Section 4.0 “Memory Organization”** in this data sheet for device-specific register and bit information.

The Inter-Integrated Circuit (I²C) module provides complete hardware support for both Slave and Multi-Master modes of the I²C serial communication standard with a 16-bit interface.

The I²C module has a 2-pin interface:

- The SCLx pin is clock.
- The SDAx pin is data.

The I²C module offers the following key features:

- I²C Interface Supporting Both Master and Slave modes of Operation
- I²C Slave mode Supports 7-Bit and 10-Bit Addressing
- I²C Master mode Supports 7-Bit and 10-Bit Addressing
- I²C Port allows Bidirectional Transfers Between Master and Slaves
- Serial Clock Synchronization for I²C Port can be used as a Handshake Mechanism to Suspend and Resume Serial Transfer (SCLREL control)
- I²C Supports Multi-Master Operation, Detects Bus Collision and Arbitrates Accordingly

19.1 Operating Modes

The hardware fully implements all the master and slave functions of the I²C Standard and Fast mode specifications, as well as 7-bit and 10-bit addressing.

The I²C module can operate either as a slave or a master on an I²C bus.

The following types of I²C operation are supported:

- I²C slave operation with 7-bit addressing
- I²C slave operation with 10-bit addressing
- I²C master operation with 7-bit or 10-bit addressing

For details about the communication sequence in each of these modes, refer to the “dsPIC33F/PIC24H Family Reference Manual”. Please see the Microchip web site (www.microchip.com) for the latest “dsPIC33F/PIC24H Family Reference Manual” sections.

19.2 I²C Registers

I2CxCON and I2CxSTAT are control and status registers, respectively. The I2CxCON register is readable and writable. The lower six bits of I2CxSTAT are read-only. The remaining bits of the I2CxSTAT are read/write:

- I2CxRSR is the shift register used for shifting data internal to the module and the user application has no access to it.
- I2CxRCV is the receive buffer and the register to which data bytes are written or from which data bytes are read.
- I2CxTRN is the transmit register to which bytes are written during a transmit operation.
- The I2CxADD register holds the slave address.
- A status bit, ADD10, indicates 10-Bit Addressing mode.
- The I2CxBRG acts as the Baud Rate Generator (BRG) reload value.

In receive operations, I2CxRSR and I2CxRCV together form a double-buffered receiver. When I2CxRSR receives a complete byte, it is transferred to I2CxRCV and an interrupt pulse is generated.

FIGURE 19-1: I²C™ BLOCK DIAGRAM (x = 1 or 2)



dsPIC33FJ32GS406/606/608/610 and dsPIC33FJ64GS406/606/608/610

REGISTER 19-1: I2CxCON: I2Cx CONTROL REGISTER

| | | | | | | | |
|--------|-----|---------|-----------|--------|-------|--------|-------|
| R/W-0 | U-0 | R/W-0 | R/W-1, HC | R/W-0 | R/W-0 | R/W-0 | R/W-0 |
| I2CEN | — | I2CSIDL | SCLREL | IPMIEN | A10M | DISSLW | SMEN |
| bit 15 | | | | | | | bit 8 |

| | | | | | | | |
|-------|-------|-------|-----------|-----------|-----------|-----------|-----------|
| R/W-0 | R/W-0 | R/W-0 | R/W-0, HC | R/W-0, HC | R/W-0, HC | R/W-0, HC | R/W-0, HC |
| GCEN | STREN | ACKDT | ACKEN | RCEN | PEN | RSEN | SEN |
| bit 7 | | | | | | | bit 0 |

| | | | |
|-------------------|-----------------------------|------------------------------------|--------------------|
| Legend: | HC = Hardware Clearable bit | | |
| R = Readable bit | W = Writable bit | U = Unimplemented bit, read as '0' | |
| -n = Value at POR | '1' = Bit is set | '0' = Bit is cleared | x = Bit is unknown |

- bit 15 **I2CEN:** I2Cx Enable bit
 1 = Enables the I2Cx module and configures the SDAx and SCLx pins as serial port pins
 0 = Disables the I2Cx module; all I²C pins are controlled by port functions
- bit 14 **Unimplemented:** Read as '0'
- bit 13 **I2CSIDL:** I2Cx Stop in Idle Mode bit
 1 = Discontinues module operation when device enters Idle mode
 0 = Continues module operation in Idle mode
- bit 12 **SCLREL:** SCLx Release Control bit (when operating as I²C slave)
 1 = Releases SCLx clock
 0 = Holds SCLx clock low (clock stretch)
If STREN = 1:
 Bit is R/W (i.e., software can write '0' to initiate stretch and write '1' to release clock). Hardware is clear at beginning of slave transmission. Hardware is clear at end of slave reception.
If STREN = 0:
 Bit is R/S (i.e., software can only write '1' to release clock). Hardware is clear at beginning of slave transmission.
- bit 11 **IPMIEN:** Intelligent Peripheral Management Interface (IPMI) Enable bit
 1 = IPMI mode is enabled; all addresses are Acknowledged
 0 = IPMI mode is disabled
- bit 10 **A10M:** 10-Bit Slave Address bit
 1 = I2CxADD is a 10-bit slave address
 0 = I2CxADD is a 7-bit slave address
- bit 9 **DISSLW:** Disable Slew Rate Control bit
 1 = Slew rate control is disabled
 0 = Slew rate control is enabled
- bit 8 **SMEN:** SMBus Input Levels bit
 1 = Enables I/O pin thresholds compliant with SMBus specification
 0 = Disables SMBus input thresholds
- bit 7 **GCEN:** General Call Enable bit (when operating as I²C slave)
 1 = Enables interrupt when a general call address is received in the I2CxRSR (module is enabled for reception)
 0 = General call address is disabled
- bit 6 **STREN:** SCLx Clock Stretch Enable bit (when operating as I²C slave)
 Used in conjunction with the SCLREL bit.
 1 = Enables software or receives clock stretching
 0 = Disables software or receives clock stretching

REGISTER 19-1: I2CxCON: I2Cx CONTROL REGISTER (CONTINUED)

- bit 5 **ACKDT:** Acknowledge Data bit (when operating as I²C master, applicable during master receive)
Value that is transmitted when the software initiates an Acknowledge sequence.
1 = Sends NACK during Acknowledge
0 = Sends ACK during Acknowledge
- bit 4 **ACKEN:** Acknowledge Sequence Enable bit (when operating as I²C master, applicable during master receive)
1 = Initiates Acknowledge sequence on SDAx and SCLx pins and transmits ACKDT data bit. Hardware clears at the end of the master Acknowledge sequence.
0 = Acknowledge sequence is not in progress
- bit 3 **RCEN:** Receive Enable bit (when operating as I²C master)
1 = Enables Receive mode for I²C. Hardware clears at the end of the eighth bit of the master receive data byte.
0 = Receive sequence is not in progress
- bit 2 **PEN:** Stop Condition Enable bit (when operating as I²C master)
1 = Initiates Stop condition on SDAx and SCLx pins. Hardware clears at the end of the master Stop sequence.
0 = Stop condition is not in progress
- bit 1 **RSEN:** Repeated Start Condition Enable bit (when operating as I²C master)
1 = Initiates Repeated Start condition on SDAx and SCLx pins. Hardware clears at the end of the master Repeated Start sequence.
0 = Repeated Start condition is not in progress
- bit 0 **SEN:** Start Condition Enable bit (when operating as I²C master)
1 = Initiates Start condition on SDAx and SCLx pins. Hardware clears at the end of the master Start sequence.
0 = Start condition is not in progress

REGISTER 19-2: I2CxSTAT: I2Cx STATUS REGISTER

| | | | | | | | |
|----------|----------|-----|-----|-----|------------|----------|----------|
| R-0, HSC | R-0, HSC | U-0 | U-0 | U-0 | R/C-0, HSC | R-0, HSC | R-0, HSC |
| ACKSTAT | TRSTAT | — | — | — | BCL | GCSTAT | ADD10 |
| bit 15 | | | | | | | bit 8 |

| | | | | | | | |
|-----------|-----------|----------|------------|------------|----------|----------|----------|
| R/C-0, HS | R/C-0, HS | R-0, HSC | R/C-0, HSC | R/C-0, HSC | R-0, HSC | R-0, HSC | R-0, HSC |
| IWCOL | I2COV | D_A | P | S | R_W | RBF | TBF |
| bit 7 | | | | | | | bit 0 |

| | | | |
|-------------------|-------------------|------------------------------------|---------------------------------------|
| Legend: | C = Clearable bit | U = Unimplemented bit, read as '0' | |
| R = Readable bit | W = Writable bit | HS = Hardware Settable bit | HSC = Hardware Settable/Clearable bit |
| -n = Value at POR | '1' = Bit is set | '0' = Bit is cleared | x = Bit is unknown |

- bit 15 **ACKSTAT:** Acknowledge Status bit (when operating as I²C master, applicable to master transmit operation)
 - 1 = NACK received from slave
 - 0 = ACK received from slave
 Hardware is set or clear at the end of slave Acknowledge.

- bit 14 **TRSTAT:** Transmit Status bit (when operating as I²C master, applicable to master transmit operation)
 - 1 = Master transmit is in progress (8 bits + ACK)
 - 0 = Master transmit is not in progress
 Hardware is set at the beginning of master transmission. Hardware is clear at the end of slave Acknowledge.

- bit 13-11 **Unimplemented:** Read as '0'

- bit 10 **BCL:** Master Bus Collision Detect bit
 - 1 = A bus collision has been detected during a master operation
 - 0 = No collision
 Hardware set at detection of bus collision.

- bit 9 **GCSTAT:** General Call Status bit
 - 1 = General call address was received
 - 0 = General call address was not received
 Hardware is set when the address matches the general call address. Hardware is clear at Stop detection.

- bit 8 **ADD10:** 10-Bit Address Status bit
 - 1 = 10-bit address was matched
 - 0 = 10-bit address was not matched
 Hardware is set at the match of the 2nd byte of matched 10-bit address. Hardware is clear at Stop detection.

- bit 7 **IWCOL:** Write Collision Detect bit
 - 1 = An attempt to write to the I2CxTRN register failed because the I²C module is busy
 - 0 = No collision
 Hardware is set at the occurrence of a write to I2CxTRN while busy (cleared by software).

- bit 6 **I2COV:** Receive Overflow Flag bit
 - 1 = A byte was received while the I2CxRCV register is still holding the previous byte
 - 0 = No overflow
 Hardware is set at an attempt to transfer I2CxRSR to I2CxRCV (cleared by software).

- bit 5 **D_A:** Data/Address bit (when operating as I²C slave)
 - 1 = Indicates that the last byte received was data
 - 0 = Indicates that the last byte received was a device address
 Hardware is clear at a device address match. Hardware is set by reception of a slave byte.

- bit 4 **P:** Stop bit
 - 1 = Indicates that a Stop bit has been detected last
 - 0 = Stop bit was not detected last
 Hardware is set or clear when Start, Repeated Start or Stop is detected.

REGISTER 19-2: I2CxSTAT: I2Cx STATUS REGISTER (CONTINUED)

- bit 3 **S:** Start bit
1 = Indicates that a Start (or Repeated Start) bit has been detected last
0 = Start bit was not detected last
Hardware is set or clear when Start, Repeated Start or Stop is detected.
- bit 2 **R_W:** Read/Write Information bit (when operating as I²C slave)
1 = Read – indicates data transfer is output from slave
0 = Write – indicates data transfer is input to slave
Hardware is set or clear after reception of an I²C device address byte.
- bit 1 **RBF:** Receive Buffer Full Status bit
1 = Receive is complete, I2CxRCV is full
0 = Receive is not complete, I2CxRCV is empty
Hardware is set when I2CxRCV is written with a received byte. Hardware is clear when software reads I2CxRCV.
- bit 0 **TBF:** Transmit Buffer Full Status bit
1 = Transmit in progress, I2CxTRN is full
0 = Transmit is complete, I2CxTRN is empty
Hardware is set when software writes to I2CxTRN. Hardware is clear at completion of the data transmission.

dsPIC33FJ32GS406/606/608/610 and dsPIC33FJ64GS406/606/608/610

REGISTER 19-3: I2CxMSK: I2Cx SLAVE MODE ADDRESS MASK REGISTER

| | | | | | | | |
|--------|-----|-----|-----|-----|-----|-----------|-------|
| U-0 | U-0 | U-0 | U-0 | U-0 | U-0 | R/W-0 | R/W-0 |
| — | — | — | — | — | — | AMSK<9:8> | |
| bit 15 | | | | | | bit 8 | |

| | | | | | | | |
|-----------|-------|-------|-------|-------|-------|-------|-------|
| R/W-0 | R/W-0 | R/W-0 | R/W-0 | R/W-0 | R/W-0 | R/W-0 | R/W-0 |
| AMSK<7:0> | | | | | | | |
| bit 7 | | | | | | bit 0 | |

Legend:

R = Readable bit

W = Writable bit

U = Unimplemented bit, read as '0'

-n = Value at POR

'1' = Bit is set

'0' = Bit is cleared

x = Bit is unknown

bit 15-10 **Unimplemented:** Read as '0'

bit 9-0 **AMSK<9:0>:** Mask for Address bit x Select bits

1 = Enables masking for bit x of incoming message address; bit match is not required in this position

0 = Disables masking for bit x; bit match is required in this position

NOTES:

20.0 UNIVERSAL ASYNCHRONOUS RECEIVER TRANSMITTER (UART)

Note 1: This data sheet summarizes the features of the dsPIC33FJ32GS406/606/608/610 and dsPIC33FJ64GS406/606/608/610 families of devices. It is not intended to be a comprehensive reference source. To complement the information in this data sheet, refer to **Section 17. “UART”** (DS70188) in the “*dsPIC33F/PIC24H Family Reference Manual*”, which is available from the Microchip web site (www.microchip.com).

2: Some registers and associated bits described in this section may not be available on all devices. Refer to **Section 4.0 “Memory Organization”** in this data sheet for device-specific register and bit information.

The Universal Asynchronous Receiver Transmitter (UART) module is one of the serial I/O modules available in the dsPIC33FJ32GS406/606/608/610 and dsPIC33FJ64GS406/606/608/610 device families. The UART is a full-duplex, asynchronous system that can communicate with peripheral devices, such as personal computers, LIN/JS2602, RS-232 and RS-485 interfaces. The module also supports a hardware flow control option with the \overline{UxCTS} and \overline{UxRTS} pins and also includes an IrDA encoder and decoder.

The primary features of the UARTx module are:

- Full-Duplex, 8-Bit or 9-Bit Data Transmission through the UxTX and UxRX Pins
- Even, Odd or No Parity Options (for 8-bit data)
- One or Two Stop bits
- Hardware Flow Control Option with \overline{UxCTS} and \overline{UxRTS} Pins
- Fully Integrated Baud Rate Generator with 16-Bit Prescaler
- Baud Rates Ranging from 10 Mbps to 38 bps at 40 MIPS
- Baud Rates Ranging from 12.5 Mbps to 47 bps at 50 MIPS
- 4-Deep, First-In First-Out (FIFO) Transmit Data Buffer
- 4-Deep FIFO Receive Data Buffer
- Parity, Framing and Buffer Overrun Error Detection
- Support for 9-Bit mode with Address Detect (9th bit = 1)
- Transmit and Receive Interrupts
- A Separate Interrupt for all UART Error Conditions
- Loopback mode for Diagnostic Support
- Support for Sync and Break Characters
- Support for Automatic Baud Rate Detection
- IrDA Encoder and Decoder Logic
- 16x Baud Clock Output for IrDA® Support
- Support for DMA

A simplified block diagram of the UART module is shown in **Figure 20-1**. The UART module consists of these key hardware elements:

- Baud Rate Generator
- Asynchronous Transmitter
- Asynchronous Receiver

FIGURE 20-1: SIMPLIFIED UARTx BLOCK DIAGRAM



dsPIC33FJ32GS406/606/608/610 and dsPIC33FJ64GS406/606/608/610

REGISTER 20-1: UxMODE: UARTx MODE REGISTER

| | | | | | | | |
|-----------------------|-----|-------|---------------------|-------|-----|----------|-------|
| R/W-0 | U-0 | R/W-0 | R/W-0 | R/W-0 | U-0 | R/W-0 | R/W-0 |
| UARTEN ⁽¹⁾ | — | USIDL | IREN ⁽²⁾ | RTSMD | — | UEN<1:0> | |
| bit 15 | | | | | | | bit 8 |

| | | | | | | | |
|-----------|--------|-----------|--------|-------|------------|-------|-------|
| R/W-0, HC | R/W-0 | R/W-0, HC | R/W-0 | R/W-0 | R/W-0 | R/W-0 | R/W-0 |
| WAKE | LPBACK | ABAUD | URXINV | BRGH | PDSEL<1:0> | | STSEL |
| bit 7 | | | | | | | bit 0 |

| | |
|-------------------|------------------------------------|
| Legend: | HC = Hardware Clearable bit |
| R = Readable bit | W = Writable bit |
| -n = Value at POR | '1' = Bit is set |
| | U = Unimplemented bit, read as '0' |
| | '0' = Bit is cleared |
| | x = Bit is unknown |

- bit 15 **UARTEN:** UARTx Enable bit⁽¹⁾
 1 = UARTx is enabled; all UARTx pins are controlled by UARTx as defined by UEN<1:0>
 0 = UARTx is disabled; all UARTx pins are controlled by port latches; UARTx power consumption minimal
- bit 14 **Unimplemented:** Read as '0'
- bit 13 **USIDL:** UARTx Stop in Idle Mode bit
 1 = Discontinues module operation when device enters Idle mode
 0 = Continues module operation in Idle mode
- bit 12 **IREN:** IrDA[®] Encoder and Decoder Enable bit⁽²⁾
 1 = IrDA encoder and decoder are enabled
 0 = IrDA encoder and decoder are disabled
- bit 11 **RTSMD:** Mode Selection for $\overline{\text{UxRTS}}$ Pin bit
 1 = $\overline{\text{UxRTS}}$ pin in Simplex mode
 0 = $\overline{\text{UxRTS}}$ pin in Flow Control mode
- bit 10 **Unimplemented:** Read as '0'
- bit 9-8 **UEN<1:0>:** UARTx Pin Enable bits
 11 = $\overline{\text{UxTX}}$, $\overline{\text{UxRX}}$ and $\overline{\text{BCLK}}$ pins are enabled and used; $\overline{\text{UxCTS}}$ pin is controlled by port latches
 10 = $\overline{\text{UxTX}}$, $\overline{\text{UxRX}}$, $\overline{\text{UxCTS}}$ and $\overline{\text{UxRTS}}$ pins are enabled and used
 01 = $\overline{\text{UxTX}}$, $\overline{\text{UxRX}}$ and $\overline{\text{UxRTS}}$ pins are enabled and used; $\overline{\text{UxCTS}}$ pin is controlled by port latches
 00 = $\overline{\text{UxTX}}$ and $\overline{\text{UxRX}}$ pins are enabled and used; $\overline{\text{UxCTS}}$ and $\overline{\text{UxRTS/BCLK}}$ pins are controlled by port latches
- bit 7 **WAKE:** Wake-up on Start bit Detect During Sleep Mode Enable bit
 1 = UARTx will continue to sample the $\overline{\text{UxRX}}$ pin; interrupt is generated on falling edge; bit is cleared in hardware on following rising edge
 0 = No wake-up is enabled
- bit 6 **LPBACK:** UARTx Loopback Mode Select bit
 1 = Enables Loopback mode
 0 = Loopback mode is disabled
- bit 5 **ABAUD:** Auto-Baud Enable bit
 1 = Enables baud rate measurement on the next character – requires reception of a Sync field (55h) before other data; cleared in hardware upon completion
 0 = Baud rate measurement is disabled or completed

Note 1: Refer to **Section 17. “UART”** (DS70188) in the “*dsPIC33F/PIC24H Family Reference Manual*” for information on enabling the UART module for receive or transmit operation. That section of the manual is available on the Microchip web site, www.microchip.com.

2: This feature is only available for the 16x BRG mode (BRGH = 0).

REGISTER 20-1: UxMODE: UARTx MODE REGISTER (CONTINUED)

| | |
|---------|--|
| bit 4 | URXINV: Receive Polarity Inversion bit 1 = UxRX Idle state is '0' 0 = UxRX Idle state is '1' |
| bit 3 | BRGH: High Baud Rate Enable bit 1 = BRG generates 4 clocks per bit period (4x baud clock, High-Speed mode) 0 = BRG generates 16 clocks per bit period (16x baud clock, Standard mode) |
| bit 2-1 | PDSEL<1:0>: Parity and Data Selection bits 11 = 9-bit data, no parity 10 = 8-bit data, odd parity 01 = 8-bit data, even parity 00 = 8-bit data, no parity |
| bit 0 | STSEL: Stop Bit Selection bit 1 = Two Stop bits 0 = One Stop bit |

Note 1: Refer to **Section 17. "UART"** (DS70188) in the "*dsPIC33F/PIC24H Family Reference Manual*" for information on enabling the UART module for receive or transmit operation. That section of the manual is available on the Microchip web site, www.microchip.com.

2: This feature is only available for the 16x BRG mode (BRGH = 0).

dsPIC33FJ32GS406/606/608/610 and dsPIC33FJ64GS406/606/608/610

REGISTER 20-2: UxSTA: UARTx STATUS AND CONTROL REGISTER

| | | | | | | | |
|----------|--------|----------|-----|-----------|----------------------|-------|-------|
| R/W-0 | R/W-0 | R/W-0 | U-0 | R/W-0, HC | R/W-0 | R-0 | R-1 |
| UTXISEL1 | UTXINV | UTXISEL0 | — | UTXBRK | UTXEN ⁽¹⁾ | UTXBF | TRMT |
| bit 15 | | | | | | | bit 8 |

| | | | | | | | |
|--------------|-------|-------|------|------|------|-------|-------|
| R/W-0 | R/W-0 | R/W-0 | R-1 | R-0 | R-0 | R/C-0 | R-0 |
| URXISEL<1:0> | | ADDEN | RIDL | PERR | FERR | OERR | URXDA |
| bit 7 | | | | | | | bit 0 |

| | | |
|-------------------|-----------------------------|------------------------------------|
| Legend: | HC = Hardware Clearable bit | C = Clearable bit |
| R = Readable bit | W = Writable bit | U = Unimplemented bit, read as '0' |
| -n = Value at POR | '1' = Bit is set | '0' = Bit is cleared |
| | | x = Bit is unknown |

- bit 15,13 **UTXISEL<1:0>**: UARTx Transmission Interrupt Mode Selection bits
- 11 = Reserved; do not use
 - 10 = Interrupt when a character is transferred to the Transmit Shift Register (TSR), and as a result, the transmit buffer becomes empty
 - 01 = Interrupt when the last character is shifted out of the Transmit Shift Register; all transmit operations are completed
 - 00 = Interrupt when a character is transferred to the Transmit Shift Register (this implies there is at least one character open in the transmit buffer)
- bit 14 **UTXINV**: UARTx Transmit Polarity Inversion bit
- If IREN = 0:
- 1 = UxTX Idle state is '0'
 - 0 = UxTX Idle state is '1'
- If IREN = 1:
- 1 = IrDA[®] encoded UxTX Idle state is '1'
 - 0 = IrDA encoded UxTX Idle state is '0'
- bit 12 **Unimplemented**: Read as '0'
- bit 11 **UTXBRK**: UARTx Transmit Break bit
- 1 = Sends Sync Break on next transmission – Start bit, followed by twelve '0' bits, followed by Stop bit; cleared by hardware upon completion
 - 0 = Sync Break transmission is disabled or completed
- bit 10 **UTXEN**: UARTx Transmit Enable bit⁽¹⁾
- 1 = Transmit is enabled, UxTX pin is controlled by UARTx
 - 0 = Transmit is disabled, any pending transmission is aborted and the buffer is reset; UxTX pin is controlled by the port
- bit 9 **UTXBF**: UARTx Transmit Buffer Full Status bit (read-only)
- 1 = Transmit buffer is full
 - 0 = Transmit buffer is not full; at least one more character can be written
- bit 8 **TRMT**: Transmit Shift Register Empty bit (read-only)
- 1 = Transmit Shift Register is empty and transmit buffer is empty (the last transmission has completed)
 - 0 = Transmit Shift Register is not empty, a transmission is in progress or queued
- bit 7-6 **URXISEL<1:0>**: UARTx Receive Interrupt Mode Selection bits
- 11 = Interrupt is set on UxRSR transfer, making the receive buffer full (i.e., has 4 data characters)
 - 10 = Interrupt is set on UxRSR transfer, making the receive buffer 3/4 full (i.e., has 3 data characters)
 - 0x = Interrupt is set when any character is received and transferred from the UxRSR to the receive buffer; receive buffer has one or more characters

Note 1: Refer to **Section 17. “UART”** (DS70188) in the “dsPIC33F/PIC24H Family Reference Manual” for information on enabling the UART module for transmit operation. That section of the manual is available on the Microchip web site, www.microchip.com.

REGISTER 20-2: UxSTA: UARTx STATUS AND CONTROL REGISTER (CONTINUED)

- bit 5 **ADDEN:** Address Character Detect bit (bit 8 of received data = 1)
 1 = Address Detect mode is enabled; if 9-bit mode is not selected, this does not take effect
 0 = Address Detect mode is disabled
- bit 4 **RIDLE:** Receiver Idle bit (read-only)
 1 = Receiver is Idle
 0 = Receiver is active
- bit 3 **PERR:** Parity Error Status bit (read-only)
 1 = Parity error has been detected for the current character (character at the top of the receive FIFO)
 0 = Parity error has not been detected
- bit 2 **FERR:** Framing Error Status bit (read-only)
 1 = Framing error has been detected for the current character (character at the top of the receive FIFO)
 0 = Framing error has not been detected
- bit 1 **OERR:** Receive Buffer Overrun Error Status bit (clear/read-only)
 1 = Receive buffer has overflowed
 0 = Receive buffer has not overflowed; clearing a previously set OERR bit (1 → 0 transition) will reset the receiver buffer and the UxRSR to the empty state
- bit 0 **URXDA:** UARTx Receive Buffer Data Available bit (read-only)
 1 = Receive buffer has data, at least one more character can be read
 0 = Receive buffer is empty

Note 1: Refer to **Section 17. “UART”** (DS70188) in the “*dsPIC33F/PIC24H Family Reference Manual*” for information on enabling the UART module for transmit operation. That section of the manual is available on the Microchip web site, www.microchip.com.

NOTES:

21.0 ENHANCED CAN (ECAN™) MODULE

Note 1: This data sheet summarizes the features of the dsPIC33FJ32GS406/606/608/610 and dsPIC33FJ64GS406/606/608/610 families of devices. It is not intended to be a comprehensive reference source. To complement the information in this data sheet, refer to **Section 21. “Enhanced Controller Area Network (ECAN™)”** (DS70185) in the *dsPIC33F/PIC24H Family Reference Manual*, which is available from the Microchip web site (www.microchip.com).

2: Some registers and associated bits described in this section may not be available on all devices. Refer to **Section 4.0 “Memory Organization”** in this data sheet for device-specific register and bit information.

- Programmable Wake-up Functionality with Integrated Low-Pass Filter
- Programmable Loopback mode Supports Self-Test Operation
- Signaling via Interrupt Capabilities for all CAN Receiver and Transmitter Error States
- Programmable Clock Source
- Programmable Link to Input Capture module (IC2 for CAN1) for Time-Stamping and Network Synchronization
- Low-Power Sleep and Idle mode

The CAN bus module consists of a protocol engine and message buffering/control. The CAN protocol engine handles all functions for receiving and transmitting messages on the CAN bus. Messages are transmitted by first loading the appropriate data registers. Status and errors can be checked by reading the appropriate registers. Any message detected on the CAN bus is checked for errors and then matched against filters to see if it should be received and stored in one of the receive registers.

21.1 Overview

The Enhanced Controller Area Network (ECAN™) module is a serial interface, useful for communicating with other CAN modules or microcontroller devices. This interface/protocol was designed to allow communications within noisy environments. The dsPIC33FJ32GS406/606/608/610 and dsPIC33FJ64GS406/606/608/610 devices contain up to two ECAN modules.

The ECAN module is a communication controller implementing the CAN 2.0 A/B protocol, as defined in the BOSCH CAN specification. The module supports CAN 1.2, CAN 2.0A, CAN 2.0B Passive and CAN 2.0B Active versions of the protocol. The module implementation is a full CAN system. The CAN specification is not covered within this data sheet. The reader can refer to the BOSCH CAN specification for further details.

The module features are as follows:

- Implementation of the CAN Protocol, CAN 1.2, CAN 2.0A and CAN 2.0B
- Standard and Extended Data Frames
- 0-8 Bytes Data Length
- Programmable Bit Rate, up to 1 Mbit/sec
- Automatic Response to Remote Transmission Requests
- Up to 8 Transmit Buffers with Application-Specified Prioritization and Abort Capability (each buffer can contain up to 8 bytes of data)
- Up to 32 Receive Buffers (each buffer can contain up to 8 bytes of data)
- Up to 16 Full (standard/extended identifier) Acceptance Filters
- Three Full Acceptance Filter Masks
- DeviceNet™ Addressing Support

21.2 Frame Types

The ECAN module transmits various types of frames which include data messages, or remote transmission requests initiated by the user, as other frames that are automatically generated for control purposes. The following frame types are supported:

- **Standard Data Frame:** A standard data frame is generated by a node when the node wishes to transmit data. It includes an 11-bit Standard Identifier (SID), but not an 18-bit Extended Identifier (EID).
- **Extended Data Frame:** An extended data frame is similar to a standard data frame, but includes an extended identifier as well.
- **Remote Frame:** It is possible for a destination node to request the data from the source. For this purpose, the destination node sends a remote frame with an identifier that matches the identifier of the required data frame. The appropriate data source node sends a data frame as a response to this remote request.
- **Error Frame:** An error frame is generated by any node that detects a bus error. An error frame consists of two fields: an error flag field and an error delimiter field.
- **Overload Frame:** An overload frame can be generated by a node as a result of two conditions. First, the node detects a dominant bit during inter-frame space which is an illegal condition. Second, due to internal conditions, the node is not yet able to start reception of the next message. A node can generate a maximum of 2 sequential overload frames to delay the start of the next message.
- **Interframe Space:** Interframe space separates a preceding frame (of whatever type) from a following data or remote frame.

FIGURE 21-1: ECANx MODULE BLOCK DIAGRAM



21.3 Modes of Operation

The ECAN™ module can operate in one of several operation modes selected by the user. These modes include:

- Initialization mode
- Disable mode
- Normal Operation mode
- Listen Only mode
- Listen All Messages mode
- Loopback mode

Modes are requested by setting the REQOP<2:0> bits (CxCTRL1<10:8>). Entry into a mode is Acknowledged by monitoring the OPMODE<2:0> bits (CxCTRL1<7:5>). The module does not change the mode and the OPMODE bits until a change in mode is acceptable, generally during bus Idle time, which is defined as at least 11 consecutive recessive bits.

21.3.1 INITIALIZATION MODE

In the Initialization mode, the module does not transmit or receive. The error counters are cleared and the interrupt flags remain unchanged. The user application has access to Configuration registers that are access restricted in other modes. The module protects the user from accidentally violating the CAN protocol through programming errors. All registers which control the configuration of the module cannot be modified while the module is on-line. The ECAN module is not allowed to enter the Configuration mode while a transmission is taking place. The Configuration mode serves as a lock to protect the following registers:

- All Module Control Registers
- Baud Rate and Interrupt Configuration Registers
- Bus Timing Registers
- Identifier Acceptance Filter Registers
- Identifier Acceptance Mask Registers

21.3.2 DISABLE MODE

In Disable mode, the module does not transmit or receive. The module has the ability to set the WAKIF bit due to bus activity, however, any pending interrupts remain and the error counters retains their value.

If the REQOP<2:0> bits (CxCTRL1<10:8>) = 001, the module enters the Module Disable mode. If the module is active, the module waits for 11 recessive bits on the CAN bus, detects that condition as an Idle bus, then accepts the module disable command. When the OPMODE<2:0> bits (CxCTRL1<7:5>) = 001, that indicates whether the module successfully went into Module Disable mode. The I/O pins revert to normal I/O function when the module is in the Module Disable mode.

The module can be programmed to apply a low-pass filter function to the CxRX input line while the module or the CPU is in Sleep mode. The WAKFIL bit (CxCFG2<14>) enables or disables the filter.

Note: Typically, if the ECAN module is allowed to transmit in a particular mode of operation, and a transmission is requested immediately after the ECAN module has been placed in that mode of operation, the module waits for 11 consecutive recessive bits on the bus before starting transmission. If the user switches to Disable mode within this 11-bit period, then this transmission is aborted and the corresponding TXABTmn bit is set and the TXREQmn bit is cleared.

21.3.3 NORMAL OPERATION MODE

Normal Operation mode is selected when REQOP<2:0> = 000. In this mode, the module is activated and the I/O pins assume the CAN bus functions. The module transmits and receives CAN bus messages via the CxTX and CxRX pins.

21.3.4 LISTEN ONLY MODE

If the Listen Only mode is activated, the module on the CAN bus is passive. The transmitter buffers revert to the port I/O function. The receive pins remain inputs. For the receiver, no error flags or Acknowledge signals are sent. The error counters are deactivated in this state. The Listen Only mode can be used for detecting the baud rate on the CAN bus. To use this, it is necessary that there are at least two further nodes that communicate with each other.

21.3.5 LISTEN ALL MESSAGES MODE

The module can be set to ignore all errors and receive any message. The Listen All Messages mode is activated by setting REQOP<2:0> = 111. In this mode, the data, which is in the message assembly buffer until the time an error occurred, is copied in the receive buffer and can be read via the CPU interface.

21.3.6 LOOPBACK MODE

If the Loopback mode is activated, the module connects the internal transmit signal to the internal receive signal at the module boundary. The transmit and receive pins revert to their port I/O function.

dsPIC33FJ32GS406/606/608/610 and dsPIC33FJ64GS406/606/608/610

REGISTER 21-1: CxCTRL1: ECANx CONTROL REGISTER 1

| | | | | | | | |
|--------|-----|-------|-------|-----|------------|-------|-------|
| U-0 | U-0 | R/W-0 | R/W-0 | r-0 | R/W-1 | R/W-0 | R/W-0 |
| — | — | CSIDL | ABAT | r | REQOP<2:0> | | |
| bit 15 | | | | | | bit 8 | |

| | | | | | | | |
|-------------|-----|-----|-----|--------|-----|-------|-------|
| R-1 | R-0 | R-0 | U-0 | R/W-0 | U-0 | U-0 | R/W-0 |
| OPMODE<2:0> | | | — | CANCAP | — | — | WIN |
| bit 7 | | | | | | bit 0 | |

| | | |
|-------------------|------------------|------------------------------------|
| Legend: | r = Reserved bit | U = Unimplemented bit, read as '0' |
| R = Readable bit | W = Writable bit | '0' = Bit is cleared |
| -n = Value at POR | '1' = Bit is set | x = Bit is unknown |

- bit 15-14 **Unimplemented:** Read as '0'
- bit 13 **CSIDL:** ECANx Stop in Idle Mode bit
 - 1 = Discontinues module operation when device enters Idle mode
 - 0 = Continues module operation in Idle mode
- bit 12 **ABAT:** Abort All Pending Transmissions bit
 - 1 = Signals all transmit buffers to abort transmission
 - 0 = Module will clear this bit when all transmissions are aborted
- bit 11 **Reserved:** Do not use
- bit 10-8 **REQOP<2:0>:** Request Operation Mode bits
 - 111 = Sets Listen All Messages mode
 - 110 = Reserved
 - 101 = Reserved
 - 100 = Sets Configuration mode
 - 011 = Sets Listen Only Mode
 - 010 = Sets Loopback mode
 - 001 = Sets Disable mode
 - 000 = Sets Normal Operation mode
- bit 7-5 **OPMODE<2:0>:** Operation Mode bits
 - 111 = Module is in Listen All Messages mode
 - 110 = Reserved
 - 101 = Reserved
 - 100 = Module is in Configuration mode
 - 011 = Module is in Listen Only mode
 - 010 = Module is in Loopback mode
 - 001 = Module is in Disable mode
 - 000 = Module is in Normal Operation mode
- bit 4 **Unimplemented:** Read as '0'
- bit 3 **CANCAP:** CAN Message Receive Timer Capture Event Enable bit
 - 1 = Enables input capture based on CAN message receive
 - 0 = Disables CAN capture
- bit 2-1 **Unimplemented:** Read as '0'
- bit 0 **WIN:** SFR Map Window Select bit
 - 1 = Use filter window
 - 0 = Use buffer window

dsPIC33FJ32GS406/606/608/610 and dsPIC33FJ64GS406/606/608/610

REGISTER 21-2: CxCTRL2: ECANx CONTROL REGISTER 2

| | | | | | | | |
|--------|-----|-----|-----|-----|-----|-----|-------|
| U-0 | U-0 | U-0 | U-0 | U-0 | U-0 | U-0 | U-0 |
| — | — | — | — | — | — | — | — |
| bit 15 | | | | | | | bit 8 |

| | | | | | | | |
|-------|-----|-----|------------|-----|-----|-------|-----|
| U-0 | U-0 | U-0 | R-0 | R-0 | R-0 | R-0 | R-0 |
| — | — | — | DNCNT<4:0> | | | | |
| bit 7 | | | | | | bit 0 | |

Legend:

R = Readable bit W = Writable bit U = Unimplemented bit, read as '0'
 -n = Value at POR '1' = Bit is set '0' = Bit is cleared x = Bit is unknown

bit 15-5 **Unimplemented:** Read as '0'
 bit 4-0 **DNCNT<4:0>:** DeviceNet™ Filter Bit Number bits
 10010-11111 = Invalid selection
 10001 = Compares up to Data Byte 3, bit 6 with EID<17>
 •
 •
 •
 00001 = Compares up to Data Byte 1, bit 7 with EID<0>
 00000 = Does not compare data bytes

dsPIC33FJ32GS406/606/608/610 and dsPIC33FJ64GS406/606/608/610

REGISTER 21-3: CxVEC: ECANx INTERRUPT CODE REGISTER

| | | | | | | | |
|--------|-----|-----|-------------|-----|-----|-----|-------|
| U-0 | U-0 | U-0 | R-0 | R-0 | R-0 | R-0 | R-0 |
| — | — | — | FILHIT<4:0> | | | | |
| bit 15 | | | | | | | bit 8 |

| | | | | | | | |
|-------|------------|-----|-----|-----|-----|-----|-------|
| U-0 | R-1 | R-0 | R-0 | R-0 | R-0 | R-0 | R-0 |
| — | ICODE<6:0> | | | | | | |
| bit 7 | | | | | | | bit 0 |

Legend:

R = Readable bit W = Writable bit U = Unimplemented bit, read as '0'
 -n = Value at POR '1' = Bit is set '0' = Bit is cleared x = Bit is unknown

bit 15-13 **Unimplemented:** Read as '0'

bit 12-8 **FILHIT<4:0>:** Filter Hit Number bits

10000-11111 = Reserved

01111 = Filter 15

•
•
•

00001 = Filter 1

00000 = Filter 0

bit 7 **Unimplemented:** Read as '0'

bit 6-0 **ICODE<6:0>:** Interrupt Flag Code bits

1000101-1111111 = Reserved

1000100 = FIFO almost full interrupt

1000011 = Receiver overflow interrupt

1000010 = Wake-up interrupt

1000001 = Error interrupt

1000000 = No interrupt

•
•
•

0010000-0111111 = Reserved

0001111 = RB15 buffer interrupt

•
•
•

0001001 = RB9 buffer interrupt

0001000 = RB8 buffer interrupt

0000111 = TRB7 buffer interrupt

0000110 = TRB6 buffer interrupt

0000101 = TRB5 buffer interrupt

0000100 = TRB4 buffer interrupt

0000011 = TRB3 buffer interrupt

0000010 = TRB2 buffer interrupt

0000001 = TRB1 buffer interrupt

0000000 = TRB0 Buffer interrupt

dsPIC33FJ32GS406/606/608/610 and dsPIC33FJ64GS406/606/608/610

REGISTER 21-4: CxFCTRL: ECANx FIFO CONTROL REGISTER

| | | | | | | | | |
|------------|-------|-------|-----|-----|-----|-----|-----|-------|
| R/W-0 | R/W-0 | R/W-0 | U-0 | U-0 | U-0 | U-0 | U-0 | |
| DMABS<2:0> | | | — | — | — | — | — | |
| bit 15 | | | | | | | | bit 8 |

| | | | | | | | | |
|-------|-----|-----|----------|-------|-------|-------|-------|-------|
| U-0 | U-0 | U-0 | R/W-0 | R/W-0 | R/W-0 | R/W-0 | R/W-0 | |
| — | — | — | FSA<4:0> | | | | | |
| bit 7 | | | | | | | | bit 0 |

Legend:

R = Readable bit W = Writable bit U = Unimplemented bit, read as '0'
 -n = Value at POR '1' = Bit is set '0' = Bit is cleared x = Bit is unknown

bit 15-13 **DMABS<2:0>**: DMA Buffer Size bits

- 111 = Reserved
- 110 = 32 buffers in DMA RAM
- 101 = 24 buffers in DMA RAM
- 100 = 16 buffers in DMA RAM
- 011 = 12 buffers in DMA RAM
- 010 = 8 buffers in DMA RAM
- 001 = 6 buffers in DMA RAM
- 000 = 4 buffers in DMA RAM

bit 12-5 **Unimplemented**: Read as '0'

bit 4-0 **FSA<4:0>**: FIFO Area Starts with Buffer bits

- 11111 = Reads Buffer RB31
- 11110 = Reads Buffer RB30
-
-
-
- 00001 = TX/RX Buffer TRB1
- 00000 = TX/RX Buffer TRB0

dsPIC33FJ32GS406/606/608/610 and dsPIC33FJ64GS406/606/608/610

REGISTER 21-5: CxFIFO: ECANx FIFO STATUS REGISTER

| | | | | | | | |
|--------|-----|----------|-----|-----|-----|-----|-------|
| U-0 | U-0 | R-0 | R-0 | R-0 | R-0 | R-0 | R-0 |
| — | — | FBP<5:0> | | | | | |
| bit 15 | | | | | | | bit 8 |

| | | | | | | | |
|-------|-----|-----------|-----|-----|-----|-----|-------|
| U-0 | U-0 | R-0 | R-0 | R-0 | R-0 | R-0 | R-0 |
| — | — | FNRB<5:0> | | | | | |
| bit 7 | | | | | | | bit 0 |

Legend:

| | | |
|-------------------|------------------|------------------------------------|
| R = Readable bit | W = Writable bit | U = Unimplemented bit, read as '0' |
| -n = Value at POR | '1' = Bit is set | '0' = Bit is cleared |
| | | x = Bit is unknown |

bit 15-14 **Unimplemented:** Read as '0'

bit 13-8 **FBP<5:0>:** FIFO Buffer Pointer bits

011111 = RB31 buffer
 011110 = RB30 buffer

•
•
•

000001 = TRB1 buffer
 000000 = TRB0 buffer

bit 7-6 **Unimplemented:** Read as '0'

bit 5-0 **FNRB<5:0>:** FIFO Next Read Buffer Pointer bits

011111 = RB31 buffer
 011110 = RB30 buffer

•
•
•

000001 = TRB1 buffer
 000000 = TRB0 buffer

REGISTER 21-6: CxINTF: ECANx INTERRUPT FLAG REGISTER

| | | | | | | | |
|--------|-----|------|------|------|-------|-------|-------|
| U-0 | U-0 | R-0 | R-0 | R-0 | R-0 | R-0 | R-0 |
| — | — | TXBO | TXBP | RXBP | TXWAR | RXWAR | EWARN |
| bit 15 | | | | | | | bit 8 |

| | | | | | | | |
|-------|-------|-------|-----|--------|--------|-------|-------|
| R/C-0 | R/C-0 | R/C-0 | U-0 | R/C-0 | R/C-0 | R/C-0 | R/C-0 |
| IVRIF | WAKIF | ERRIF | — | FIFOIF | RBOVIF | RBIF | TBIF |
| bit 7 | | | | | | | bit 0 |

| | |
|-------------------|---|
| Legend: | C = Writeable, but only '0' can be written to clear the bit |
| R = Readable bit | W = Writable bit |
| -n = Value at POR | '1' = Bit is set |
| | U = Unimplemented bit, read as '0' |
| | '0' = Bit is cleared |
| | x = Bit is unknown |

- bit 15-14 **Unimplemented:** Read as '0'
- bit 13 **TXBO:** Transmitter in Error State Bus Off bit
1 = Transmitter is in Bus Off state
0 = Transmitter is not in Bus Off state
- bit 12 **TXBP:** Transmitter in Error State Bus Passive bit
1 = Transmitter is in Bus Passive state
0 = Transmitter is not in Bus Passive state
- bit 11 **RXBP:** Receiver in Error State Bus Passive bit
1 = Receiver is in Bus Passive state
0 = Receiver is not in Bus Passive state
- bit 10 **TXWAR:** Transmitter in Error State Warning bit
1 = Transmitter is in Error Warning state
0 = Transmitter is not in Error Warning state
- bit 9 **RXWAR:** Receiver in Error State Warning bit
1 = Receiver is in Error Warning state
0 = Receiver is not in Error Warning state
- bit 8 **EWARN:** Transmitter or Receiver in Error State Warning bit
1 = Transmitter or receiver is in Error Warning state
0 = Transmitter or receiver is not in Error Warning state
- bit 7 **IVRIF:** Invalid Message Received Interrupt Flag bit
1 = Interrupt request has occurred
0 = Interrupt request has not occurred
- bit 6 **WAKIF:** Bus Wake-up Activity Interrupt Flag bit
1 = Interrupt request has occurred
0 = Interrupt request has not occurred
- bit 5 **ERRIF:** Error Interrupt Flag bit (multiple sources in CxINTF<13:8> register)
1 = Interrupt request has occurred
0 = Interrupt request has not occurred
- bit 4 **Unimplemented:** Read as '0'
- bit 3 **FIFOIF:** FIFO Almost Full Interrupt Flag bit
1 = Interrupt request has occurred
0 = Interrupt request has not occurred
- bit 2 **RBOVIF:** RX Buffer Overflow Interrupt Flag bit
1 = Interrupt request has occurred
0 = Interrupt request has not occurred

REGISTER 21-6: CxINTF: ECANx INTERRUPT FLAG REGISTER (CONTINUED)

- bit 1 **RBIF:** RX Buffer Interrupt Flag bit
 1 = Interrupt request has occurred
 0 = Interrupt request has not occurred
- bit 0 **TBIF:** TX Buffer Interrupt Flag bit
 1 = Interrupt request has occurred
 0 = Interrupt request has not occurred

REGISTER 21-7: CxINTE: ECANx INTERRUPT ENABLE REGISTER

| | | | | | | | |
|--------|-----|-----|-----|-----|-----|-----|-------|
| U-0 | U-0 | U-0 | U-0 | U-0 | U-0 | U-0 | U-0 |
| — | — | — | — | — | — | — | — |
| bit 15 | | | | | | | bit 8 |

| | | | | | | | |
|-------|-------|-------|-----|--------|--------|-------|-------|
| R/W-0 | R/W-0 | R/W-0 | U-0 | R/W-0 | R/W-0 | R/W-0 | R/W-0 |
| IVRIE | WAKIE | ERRIE | — | FIFOIE | RBOVIE | RBIE | TBIE |
| bit 7 | | | | | | | bit 0 |

| | | | |
|-------------------|------------------|------------------------------------|--------------------|
| Legend: | | | |
| R = Readable bit | W = Writable bit | U = Unimplemented bit, read as '0' | |
| -n = Value at POR | '1' = Bit is set | '0' = Bit is cleared | x = Bit is unknown |

- bit 15-8 **Unimplemented:** Read as '0'
- bit 7 **IVRIE:** Invalid Message Received Interrupt Enable bit
 - 1 = Interrupt request is enabled
 - 0 = Interrupt request is not enabled
- bit 6 **WAKIE:** Bus Wake-up Activity Interrupt Flag bit
 - 1 = Interrupt request is enabled
 - 0 = Interrupt request is not enabled
- bit 5 **ERRIE:** Error Interrupt Enable bit
 - 1 = Interrupt request is enabled
 - 0 = Interrupt request is not enabled
- bit 4 **Unimplemented:** Read as '0'
- bit 3 **FIFOIE:** FIFO Almost Full Interrupt Enable bit
 - 1 = Interrupt request is enabled
 - 0 = Interrupt request is not enabled
- bit 2 **RBOVIE:** RX Buffer Overflow Interrupt Enable bit
 - 1 = Interrupt request is enabled
 - 0 = Interrupt request is not enabled
- bit 1 **RBIE:** RX Buffer Interrupt Enable bit
 - 1 = Interrupt request is enabled
 - 0 = Interrupt request is not enabled
- bit 0 **TBIE:** TX Buffer Interrupt Enable bit
 - 1 = Interrupt request is enabled
 - 0 = Interrupt request is not enabled

dsPIC33FJ32GS406/606/608/610 and dsPIC33FJ64GS406/606/608/610

REGISTER 21-8: CxEC: ECANx TRANSMIT/RECEIVE ERROR COUNT REGISTER

| | | | | | | | |
|--------------|-----|-----|-----|-------|-----|-----|-----|
| R-0 | R-0 | R-0 | R-0 | R-0 | R-0 | R-0 | R-0 |
| TERRCNT<7:0> | | | | | | | |
| bit 15 | | | | bit 8 | | | |

| | | | | | | | |
|--------------|-----|-----|-----|-------|-----|-----|-----|
| R-0 | R-0 | R-0 | R-0 | R-0 | R-0 | R-0 | R-0 |
| RERRCNT<7:0> | | | | | | | |
| bit 7 | | | | bit 0 | | | |

Legend:

R = Readable bit W = Writable bit U = Unimplemented bit, read as '0'
 -n = Value at POR '1' = Bit is set '0' = Bit is cleared x = Bit is unknown

bit 15-8 **TERRCNT<7:0>**: Transmit Error Count bits

bit 7-0 **RERRCNT<7:0>**: Receive Error Count bits

REGISTER 21-9: CxCFG1: ECANx BAUD RATE CONFIGURATION REGISTER 1

| | | | | | | | |
|--------|-----|-----|-----|-------|-----|-----|-----|
| U-0 | U-0 | U-0 | U-0 | U-0 | U-0 | U-0 | U-0 |
| — | — | — | — | — | — | — | — |
| bit 15 | | | | bit 8 | | | |

| | | | | | | | |
|----------|-------|----------|-------|-------|-------|-------|-------|
| R/W-0 | R/W-0 | R/W-0 | R/W-0 | R/W-0 | R/W-0 | R/W-0 | R/W-0 |
| SJW<1:0> | | BRP<5:0> | | | | | |
| bit 7 | | | | bit 0 | | | |

Legend:

R = Readable bit W = Writable bit U = Unimplemented bit, read as '0'
 -n = Value at POR '1' = Bit is set '0' = Bit is cleared x = Bit is unknown

bit 15-8 **Unimplemented:** Read as '0'

bit 7-6 **SJW<1:0>**: Synchronization Jump Width bits

- 11 = Length is 4 x TQ
- 10 = Length is 3 x TQ
- 01 = Length is 2 x TQ
- 00 = Length is 1 x TQ

bit 5-0 **BRP<5:0>**: Baud Rate Prescaler bits

- 11 1111 = TQ = 2 x 64 x 1/FCAN
-
-
-
- 00 0010 = TQ = 2 x 3 x 1/FCAN
- 00 0001 = TQ = 2 x 2 x 1/FCAN
- 00 0000 = TQ = 2 x 1 x 1/FCAN

dsPIC33FJ32GS406/606/608/610 and dsPIC33FJ64GS406/606/608/610

REGISTER 21-10: CxCFG2: ECANx BAUD RATE CONFIGURATION REGISTER 2

| | | | | | | | |
|--------|--------|-----|-----|-----|-------------|-------|-------|
| U-0 | R/W-x | U-0 | U-0 | U-0 | R/W-x | R/W-x | R/W-x |
| — | WAKFIL | — | — | — | SEG2PH<2:0> | | |
| bit 15 | | | | | | bit 8 | |

| | | | | | | | |
|----------|-------|-------------|-------|-------|------------|-------|-------|
| R/W-x | R/W-x | R/W-x | R/W-x | R/W-x | R/W-x | R/W-x | R/W-x |
| SEG2PHTS | SAM | SEG1PH<2:0> | | | PRSEG<2:0> | | |
| bit 7 | | | | | | bit 0 | |

Legend:

R = Readable bit W = Writable bit U = Unimplemented bit, read as '0'
 -n = Value at POR '1' = Bit is set '0' = Bit is cleared x = Bit is unknown

- bit 15 **Unimplemented:** Read as '0'
- bit 14 **WAKFIL:** Select CAN Bus Line Filter for Wake-up bit
 - 1 = Uses CAN bus line filter for wake-up
 - 0 = CAN bus line filter is not used for wake-up
- bit 13-11 **Unimplemented:** Read as '0'
- bit 10-8 **SEG2PH<2:0>:** Phase Segment 2 bits
 - 111 = Length is 8 x T_Q
 -
 -
 -
 - 000 = Length is 1 x T_Q
- bit 7 **SEG2PHTS:** Phase Segment 2 Time Select bit
 - 1 = Freely programmable
 - 0 = Maximum of SEG1PH bits or Information Processing Time (IPT), whichever is greater
- bit 6 **SAM:** Sample of the CAN Bus Line bit
 - 1 = Bus line is sampled three times at the sample point
 - 0 = Bus line is sampled once at the sample point
- bit 5-3 **SEG1PH<2:0>:** Phase Segment 1 bits
 - 111 = Length is 8 x T_Q
 -
 -
 -
 - 000 = Length is 1 x T_Q
- bit 2-0 **PRSEG<2:0>:** Propagation Time Segment bits
 - 111 = Length is 8 x T_Q
 -
 -
 -
 - 000 = Length is 1 x T_Q

dsPIC33FJ32GS406/606/608/610 and dsPIC33FJ64GS406/606/608/610

REGISTER 21-11: CxFEN1: ECANx ACCEPTANCE FILTER ENABLE REGISTER 1

| | | | | | | | |
|---------|---------|---------|---------|---------|---------|--------|--------|
| R/W-1 | R/W-1 | R/W-1 | R/W-1 | R/W-1 | R/W-1 | R/W-1 | R/W-1 |
| FLTEN15 | FLTEN14 | FLTEN13 | FLTEN12 | FLTEN11 | FLTEN10 | FLTEN9 | FLTEN8 |
| bit 15 | | | | | | | bit 8 |

| | | | | | | | |
|--------|--------|--------|--------|--------|--------|--------|--------|
| R/W-1 | R/W-1 | R/W-1 | R/W-1 | R/W-1 | R/W-1 | R/W-1 | R/W-1 |
| FLTEN7 | FLTEN6 | FLTEN5 | FLTEN4 | FLTEN3 | FLTEN2 | FLTEN1 | FLTEN0 |
| bit 7 | | | | | | | bit 0 |

Legend:

R = Readable bit W = Writable bit U = Unimplemented bit, read as '0'
 -n = Value at POR '1' = Bit is set '0' = Bit is cleared x = Bit is unknown

bit 15-0 **FLTEN<15:0>**: Enable Filter n to Accept Messages bits
 1 = Enables Filter n
 0 = Disables Filter n

REGISTER 21-12: CxBUFNT1: ECANx FILTER 0-3 BUFFER POINTER REGISTER 1

| | | | | | | | |
|-----------|-------|-------|-------|-----------|-------|-------|-------|
| R/W-0 | R/W-0 | R/W-0 | R/W-0 | R/W-0 | R/W-0 | R/W-0 | R/W-0 |
| F3BP<3:0> | | | | F2BP<3:0> | | | |
| bit 15 | | | | | | | bit 8 |

| | | | | | | | |
|-----------|-------|-------|-------|-----------|-------|-------|-------|
| R/W-0 | R/W-0 | R/W-0 | R/W-0 | R/W-0 | R/W-0 | R/W-0 | R/W-0 |
| F1BP<3:0> | | | | F0BP<3:0> | | | |
| bit 7 | | | | | | | bit 0 |

Legend:

R = Readable bit W = Writable bit U = Unimplemented bit, read as '0'
 -n = Value at POR '1' = Bit is set '0' = Bit is cleared x = Bit is unknown

bit 15-12 **F3BP<3:0>**: RX Buffer Mask for Filter 3 bits
 1111 = Filter hits received in RX FIFO buffer
 1110 = Filter hits received in RX Buffer 14
 •
 •
 •
 0001 = Filter hits received in RX Buffer 1
 0000 = Filter hits received in RX Buffer 0

bit 11-8 **F2BP<3:0>**: RX Buffer Mask for Filter 2 bits (same values as bit 15-12)

bit 7-4 **F1BP<3:0>**: RX Buffer Mask for Filter 1 bits (same values as bit 15-12)

bit 3-0 **F0BP<3:0>**: RX Buffer Mask for Filter 0 bits (same values as bit 15-12)

dsPIC33FJ32GS406/606/608/610 and dsPIC33FJ64GS406/606/608/610

REGISTER 21-13: CxBUFPNT2: ECANx FILTER 4-7 BUFFER POINTER REGISTER 2

| | | | | | | | |
|-----------|-------|-------|-------|-----------|-------|-------|-------|
| R/W-0 | R/W-0 | R/W-0 | R/W-0 | R/W-0 | R/W-0 | R/W-0 | R/W-0 |
| F7BP<3:0> | | | | F6BP<3:0> | | | |
| bit 15 | | | | bit 8 | | | |

| | | | | | | | |
|-----------|-------|-------|-------|-----------|-------|-------|-------|
| R/W-0 | R/W-0 | R/W-0 | R/W-0 | R/W-0 | R/W-0 | R/W-0 | R/W-0 |
| F5BP<3:0> | | | | F4BP<3:0> | | | |
| bit 7 | | | | bit 0 | | | |

Legend:

| | | |
|-------------------|------------------|--|
| R = Readable bit | W = Writable bit | U = Unimplemented bit, read as '0' |
| -n = Value at POR | '1' = Bit is set | '0' = Bit is cleared x = Bit is unknown |

bit 15-12 **F7BP<3:0>**: RX Buffer Mask for Filter 7 bits
 1111 = Filter hits received in RX FIFO buffer
 1110 = Filter hits received in RX Buffer 14
 •
 •
 •
 0001 = Filter hits received in RX Buffer 1
 0000 = Filter hits received in RX Buffer 0

bit 11-8 **F6BP<3:0>**: RX Buffer Mask for Filter 6 bits (same values as bit 15-12)

bit 7-4 **F5BP<3:0>**: RX Buffer Mask for Filter 5 bits (same values as bit 15-12)

bit 3-0 **F4BP<3:0>**: RX Buffer Mask for Filter 4 bits (same values as bit 15-12)

dsPIC33FJ32GS406/606/608/610 and dsPIC33FJ64GS406/606/608/610

REGISTER 21-14: CxBUFPNT3: ECANx FILTER 8-11 BUFFER POINTER REGISTER 3

| | | | | | | | |
|------------|-------|-------|-------|------------|-------|-------|-------|
| R/W-0 | R/W-0 | R/W-0 | R/W-0 | R/W-0 | R/W-0 | R/W-0 | R/W-0 |
| F11BP<3:0> | | | | F10BP<3:0> | | | |
| bit 15 | | | | bit 8 | | | |

| | | | | | | | |
|-----------|-------|-------|-------|-----------|-------|-------|-------|
| R/W-0 | R/W-0 | R/W-0 | R/W-0 | R/W-0 | R/W-0 | R/W-0 | R/W-0 |
| F9BP<3:0> | | | | F8BP<3:0> | | | |
| bit 7 | | | | bit 0 | | | |

Legend:

| | | |
|-------------------|------------------|--|
| R = Readable bit | W = Writable bit | U = Unimplemented bit, read as '0' |
| -n = Value at POR | '1' = Bit is set | '0' = Bit is cleared x = Bit is unknown |

bit 15-12 **F11BP<3:0>**: RX Buffer Mask for Filter 11 bits

1111 = Filter hits received in RX FIFO buffer
 1110 = Filter hits received in RX Buffer 14

-
-
-

0001 = Filter hits received in RX Buffer 1
 0000 = Filter hits received in RX Buffer 0

bit 11-8 **F10BP<3:0>**: RX Buffer Mask for Filter 10 bits (same values as bit 15-12)

bit 7-4 **F9BP<3:0>**: RX Buffer Mask for Filter 9 bits (same values as bit 15-12)

bit 3-0 **F8BP<3:0>**: RX Buffer Mask for Filter 8 bits (same values as bit 15-12)

dsPIC33FJ32GS406/606/608/610 and dsPIC33FJ64GS406/606/608/610

REGISTER 21-15: CxBUFPNT4: ECANx FILTER 12-15 BUFFER POINTER REGISTER 4

| | | | | | | | |
|------------|-------|-------|-------|------------|-------|-------|-------|
| R/W-0 | R/W-0 | R/W-0 | R/W-0 | R/W-0 | R/W-0 | R/W-0 | R/W-0 |
| F15BP<3:0> | | | | F14BP<3:0> | | | |
| bit 15 | | | | bit 8 | | | |

| | | | | | | | |
|------------|-------|-------|-------|------------|-------|-------|-------|
| R/W-0 | R/W-0 | R/W-0 | R/W-0 | R/W-0 | R/W-0 | R/W-0 | R/W-0 |
| F13BP<3:0> | | | | F12BP<3:0> | | | |
| bit 7 | | | | bit 0 | | | |

Legend:

R = Readable bit

W = Writable bit

U = Unimplemented bit, read as '0'

-n = Value at POR

'1' = Bit is set

'0' = Bit is cleared

x = Bit is unknown

bit 15-12 **F15BP<3:0>**: RX Buffer Mask for Filter 15 bits

1111 = Filter hits received in RX FIFO buffer

1110 = Filter hits received in RX Buffer 14

•

•

•

0001 = Filter hits received in RX Buffer 1

0000 = Filter hits received in RX Buffer 0

bit 11-8 **F14BP<3:0>**: RX Buffer Mask for Filter 14 bits (same values as bit 15-12)

bit 7-4 **F13BP<3:0>**: RX Buffer Mask for Filter 13 bits (same values as bit 15-12)

bit 3-0 **F12BP<3:0>**: RX Buffer Mask for Filter 12 bits (same values as bit 15-12)

dsPIC33FJ32GS406/606/608/610 and dsPIC33FJ64GS406/606/608/610

REGISTER 21-16: CxRXFnSID: ECANx ACCEPTANCE FILTER n STANDARD IDENTIFIER REGISTER (n = 0-15)

| | | | | | | | |
|--------|-------|-------|-------|-------|-------|-------|-------|
| R/W-x | R/W-x | R/W-x | R/W-x | R/W-x | R/W-x | R/W-x | R/W-x |
| SID10 | SID9 | SID8 | SID7 | SID6 | SID5 | SID4 | SID3 |
| bit 15 | | | | | | | bit 8 |

| | | | | | | | |
|-------|-------|-------|-----|-------|-----|-------|-------|
| R/W-x | R/W-x | R/W-x | U-0 | R/W-x | U-0 | R/W-x | R/W-x |
| SID2 | SID1 | SID0 | — | EXIDE | — | EID17 | EID16 |
| bit 7 | | | | | | | bit 0 |

Legend:

R = Readable bit W = Writable bit U = Unimplemented bit, read as '0'
 -n = Value at POR '1' = Bit is set '0' = Bit is cleared x = Bit is unknown

- bit 15-5 **SID<10:0>**: Standard Identifier bits
 - 1 = Message address bit, SIDx, must be '1' to match filter
 - 0 = Message address bit, SIDx, must be '0' to match filter
- bit 4 **Unimplemented**: Read as '0'
- bit 3 **EXIDE**: Extended Identifier Enable bit
 - If MIDE = 1, then:
 - 1 = Matches only messages with extended identifier addresses
 - 0 = Matches only messages with standard identifier addresses
 - If MIDE = 0, then:
 - Ignores EXIDE bit.
- bit 2 **Unimplemented**: Read as '0'
- bit 1-0 **EID<17:16>**: Extended Identifier bits
 - 1 = Message address bit, EIDx, must be '1' to match filter
 - 0 = Message address bit, EIDx, must be '0' to match filter

dsPIC33FJ32GS406/606/608/610 and dsPIC33FJ64GS406/606/608/610

REGISTER 21-17: CxRXFnEID: ECANx ACCEPTANCE FILTER n EXTENDED IDENTIFIER REGISTER (n = 0-15)

| | | | | | | | |
|--------|-------|-------|-------|-------|-------|-------|-------|
| R/W-x | R/W-x | R/W-x | R/W-x | R/W-x | R/W-x | R/W-x | R/W-x |
| EID15 | EID14 | EID13 | EID12 | EID11 | EID10 | EID9 | EID8 |
| bit 15 | | | | | | | bit 8 |

| | | | | | | | |
|-------|-------|-------|-------|-------|-------|-------|-------|
| R/W-x | R/W-x | R/W-x | R/W-x | R/W-x | R/W-x | R/W-x | R/W-x |
| EID7 | EID6 | EID5 | EID4 | EID3 | EID2 | EID1 | EID0 |
| bit 7 | | | | | | | bit 0 |

Legend:

R = Readable bit W = Writable bit U = Unimplemented bit, read as '0'
-n = Value at POR '1' = Bit is set '0' = Bit is cleared x = Bit is unknown

bit 15-0 **EID<15:0>**: Extended Identifier bits
1 = Message address bit, EIDx, must be '1' to match filter
0 = Message address bit, EIDx, must be '0' to match filter

REGISTER 21-18: CxFMSKSEL1: ECANx FILTER 7-0 MASK SELECTION REGISTER 1

| | | | | | | | |
|------------|-------|------------|-------|------------|-------|------------|-------|
| R/W-0 | R/W-0 | R/W-0 | R/W-0 | R/W-0 | R/W-0 | R/W-0 | R/W-0 |
| F7MSK<1:0> | | F6MSK<1:0> | | F5MSK<1:0> | | F4MSK<1:0> | |
| bit 15 | | | | | | | bit 8 |

| | | | | | | | |
|------------|-------|------------|-------|------------|-------|------------|-------|
| R/W-0 | R/W-0 | R/W-0 | R/W-0 | R/W-0 | R/W-0 | R/W-0 | R/W-0 |
| F3MSK<1:0> | | F2MSK<1:0> | | F1MSK<1:0> | | F0MSK<1:0> | |
| bit 7 | | | | | | | bit 0 |

Legend:

R = Readable bit W = Writable bit U = Unimplemented bit, read as '0'
-n = Value at POR '1' = Bit is set '0' = Bit is cleared x = Bit is unknown

bit 15-14 **F7MSK<1:0>**: Mask Source for Filter 7 bits
11 = Reserved
10 = Acceptance Mask 2 registers contain mask
01 = Acceptance Mask 1 registers contain mask
00 = Acceptance Mask 0 registers contain mask

bit 13-12 **F6MSK<1:0>**: Mask Source for Filter 6 bits (same values as bit 15-14)

bit 11-10 **F5MSK<1:0>**: Mask Source for Filter 5 bits (same values as bit 15-14)

bit 9-8 **F4MSK<1:0>**: Mask Source for Filter 4 bits (same values as bit 15-14)

bit 7-6 **F3MSK<1:0>**: Mask Source for Filter 3 bits (same values as bit 15-14)

bit 5-4 **F2MSK<1:0>**: Mask Source for Filter 2 bits (same values as bit 15-14)

bit 3-2 **F1MSK<1:0>**: Mask Source for Filter 1 bits (same values as bit 15-14)

bit 1-0 **F0MSK<1:0>**: Mask Source for Filter 0 bits (same values as bit 15-14)

dsPIC33FJ32GS406/606/608/610 and dsPIC33FJ64GS406/606/608/610

REGISTER 21-19: CxFMSKSEL2: ECANx FILTER 15-8 MASK SELECTION REGISTER 2

| | | | | | | | |
|-------------|-------|-------------|-------|-------------|-------|-------------|-------|
| R/W-0 | R/W-0 | R/W-0 | R/W-0 | R/W-0 | R/W-0 | R/W-0 | R/W-0 |
| F15MSK<1:0> | | F14MSK<1:0> | | F13MSK<1:0> | | F12MSK<1:0> | |
| bit 15 | | | | | | | bit 8 |

| | | | | | | | |
|-------------|-------|-------------|-------|------------|-------|------------|-------|
| R/W-0 | R/W-0 | R/W-0 | R/W-0 | R/W-0 | R/W-0 | R/W-0 | R/W-0 |
| F11MSK<1:0> | | F10MSK<1:0> | | F9MSK<1:0> | | F8MSK<1:0> | |
| bit 7 | | | | | | | bit 0 |

Legend:

R = Readable bit

W = Writable bit

U = Unimplemented bit, read as '0'

-n = Value at POR

'1' = Bit is set

'0' = Bit is cleared

x = Bit is unknown

bit 15-14 **F15MSK<1:0>**: Mask Source for Filter 15 bits

11 = Reserved

10 = Acceptance Mask 2 registers contain mask

01 = Acceptance Mask 1 registers contain mask

00 = Acceptance Mask 0 registers contain mask

bit 13-12 **F14MSK<1:0>**: Mask Source for Filter 14 bits (same values as bit 15-14)

bit 11-10 **F13MSK<1:0>**: Mask Source for Filter 13 bits (same values as bit 15-14)

bit 9-8 **F12MSK<1:0>**: Mask Source for Filter 12 bits (same values as bit 15-14)

bit 7-6 **F11MSK<1:0>**: Mask Source for Filter 11 bits (same values as bit 15-14)

bit 5-4 **F10MSK<1:0>**: Mask Source for Filter 10 bits (same values as bit 15-14)

bit 3-2 **F9MSK<1:0>**: Mask Source for Filter 9 bits (same values as bit 15-14)

bit 1-0 **F8MSK<1:0>**: Mask Source for Filter 8 bits (same values as bit 15-14)

dsPIC33FJ32GS406/606/608/610 and dsPIC33FJ64GS406/606/608/610

REGISTER 21-20: CxRXMnSID: ECANx ACCEPTANCE FILTER MASK n STANDARD IDENTIFIER REGISTER (n = 0-2)

| | | | | | | | |
|--------|-------|-------|-------|-------|-------|-------|-------|
| R/W-x | R/W-x | R/W-x | R/W-x | R/W-x | R/W-x | R/W-x | R/W-x |
| SID10 | SID9 | SID8 | SID7 | SID6 | SID5 | SID4 | SID3 |
| bit 15 | | | | | | | bit 8 |

| | | | | | | | |
|-------|-------|-------|-----|-------|-----|-------|-------|
| R/W-x | R/W-x | R/W-x | U-0 | R/W-x | U-0 | R/W-x | R/W-x |
| SID2 | SID1 | SID0 | — | MIDE | — | EID17 | EID16 |
| bit 7 | | | | | | | bit 0 |

Legend:

R = Readable bit W = Writable bit U = Unimplemented bit, read as '0'
-n = Value at POR '1' = Bit is set '0' = Bit is cleared x = Bit is unknown

- bit 15-5 **SID<10:0>**: Standard Identifier bits
 - 1 = Includes bit, SIDx, in filter comparison
 - 0 = SIDx bit is don't care in filter comparison
- bit 4 **Unimplemented**: Read as '0'
- bit 3 **MIDE**: Identifier Receive Mode bit
 - 1 = Matches only message types (standard or extended address) that correspond to EXIDE bit in filter
 - 0 = Matches either standard or extended address message if filters match (i.e., if (Filter SID) = (Message SID) or if (Filter SID/EID) = (Message SID/EID))
- bit 2 **Unimplemented**: Read as '0'
- bit 1-0 **EID<17:16>**: Extended Identifier bits
 - 1 = Includes bit, EIDx, in filter comparison
 - 0 = EIDx bit is don't care in filter comparison

REGISTER 21-21: CxRXMnEID: ECANx ACCEPTANCE FILTER MASK n EXTENDED IDENTIFIER REGISTER (n = 0-2)

| | | | | | | | |
|--------|-------|-------|-------|-------|-------|-------|-------|
| R/W-x | R/W-x | R/W-x | R/W-x | R/W-x | R/W-x | R/W-x | R/W-x |
| EID15 | EID14 | EID13 | EID12 | EID11 | EID10 | EID9 | EID8 |
| bit 15 | | | | | | | bit 8 |

| | | | | | | | |
|-------|-------|-------|-------|-------|-------|-------|-------|
| R/W-x | R/W-x | R/W-x | R/W-x | R/W-x | R/W-x | R/W-x | R/W-x |
| EID7 | EID6 | EID5 | EID4 | EID3 | EID2 | EID1 | EID0 |
| bit 7 | | | | | | | bit 0 |

Legend:

R = Readable bit W = Writable bit U = Unimplemented bit, read as '0'
-n = Value at POR '1' = Bit is set '0' = Bit is cleared x = Bit is unknown

- bit 15-0 **EID<15:0>**: Extended Identifier bits
 - 1 = Includes bit, EIDx, in filter comparison
 - 0 = EIDx bit is don't care in filter comparison

dsPIC33FJ32GS406/606/608/610 and dsPIC33FJ64GS406/606/608/610

REGISTER 21-22: CxRXFUL1: ECANx RECEIVE BUFFER FULL REGISTER 1

| | | | | | | | |
|---------|---------|---------|---------|---------|---------|--------|--------|
| R/C-0 | R/C-0 | R/C-0 | R/C-0 | R/C-0 | R/C-0 | R/C-0 | R/C-0 |
| RXFUL15 | RXFUL14 | RXFUL13 | RXFUL12 | RXFUL11 | RXFUL10 | RXFUL9 | RXFUL8 |
| bit 15 | | | | | | | bit 8 |

| | | | | | | | |
|--------|--------|--------|--------|--------|--------|--------|--------|
| R/C-0 | R/C-0 | R/C-0 | R/C-0 | R/C-0 | R/C-0 | R/C-0 | R/C-0 |
| RXFUL7 | RXFUL6 | RXFUL5 | RXFUL4 | RXFUL3 | RXFUL2 | RXFUL1 | RXFUL0 |
| bit 7 | | | | | | | bit 0 |

| | |
|-------------------|--|
| Legend: | C = Writeable, but only '0' can be written to clear the bit |
| R = Readable bit | W = Writable bit U = Unimplemented bit, read as '0' |
| -n = Value at POR | '1' = Bit is set '0' = Bit is cleared x = Bit is unknown |

bit 15-0 **RXFUL<15:0>**: Receive Buffer n Full bits
 1 = Buffer is full (set by module)
 0 = Buffer is empty

REGISTER 21-23: CxRXFUL2: ECANx RECEIVE BUFFER FULL REGISTER 2

| | | | | | | | |
|---------|---------|---------|---------|---------|---------|---------|---------|
| R/C-0 | R/C-0 | R/C-0 | R/C-0 | R/C-0 | R/C-0 | R/C-0 | R/C-0 |
| RXFUL31 | RXFUL30 | RXFUL29 | RXFUL28 | RXFUL27 | RXFUL26 | RXFUL25 | RXFUL24 |
| bit 15 | | | | | | | bit 8 |

| | | | | | | | |
|---------|---------|---------|---------|---------|---------|---------|---------|
| R/C-0 | R/C-0 | R/C-0 | R/C-0 | R/C-0 | R/C-0 | R/C-0 | R/C-0 |
| RXFUL23 | RXFUL22 | RXFUL21 | RXFUL20 | RXFUL19 | RXFUL18 | RXFUL17 | RXFUL16 |
| bit 7 | | | | | | | bit 0 |

| | |
|-------------------|--|
| Legend: | C = Writeable, but only '0' can be written to clear the bit |
| R = Readable bit | W = Writable bit U = Unimplemented bit, read as '0' |
| -n = Value at POR | '1' = Bit is set '0' = Bit is cleared x = Bit is unknown |

bit 15-0 **RXFUL<31:16>**: Receive Buffer n Full bits
 1 = Buffer is full (set by module)
 0 = Buffer is empty

dsPIC33FJ32GS406/606/608/610 and dsPIC33FJ64GS406/606/608/610

REGISTER 21-24: CxRXOVF1: ECANx RECEIVE BUFFER OVERFLOW REGISTER 1

| | | | | | | | |
|---------|---------|---------|---------|---------|---------|--------|--------|
| R/C-0 | R/C-0 | R/C-0 | R/C-0 | R/C-0 | R/C-0 | R/C-0 | R/C-0 |
| RXOVF15 | RXOVF14 | RXOVF13 | RXOVF12 | RXOVF11 | RXOVF10 | RXOVF9 | RXOVF8 |
| bit 15 | | | | | | | bit 8 |

| | | | | | | | |
|--------|--------|--------|--------|--------|--------|--------|--------|
| R/C-0 | R/C-0 | R/C-0 | R/C-0 | R/C-0 | R/C-0 | R/C-0 | R/C-0 |
| RXOVF7 | RXOVF6 | RXOVF5 | RXOVF4 | RXOVF3 | RXOVF2 | RXOVF1 | RXOVF0 |
| bit 7 | | | | | | | bit 0 |

| | |
|-------------------|--|
| Legend: | C = Writeable, but only '0' can be written to clear the bit |
| R = Readable bit | W = Writable bit U = Unimplemented bit, read as '0' |
| -n = Value at POR | '1' = Bit is set '0' = Bit is cleared x = Bit is unknown |

bit 15-0 **RXOVF<15:0>**: Receive Buffer n Overflow bits
 1 = Module attempted to write to a full buffer (set by module)
 0 = No overflow condition

REGISTER 21-25: CxRXOVF2: ECANx RECEIVE BUFFER OVERFLOW REGISTER 2

| | | | | | | | |
|---------|---------|---------|---------|---------|---------|---------|---------|
| R/C-0 | R/C-0 | R/C-0 | R/C-0 | R/C-0 | R/C-0 | R/C-0 | R/C-0 |
| RXOVF31 | RXOVF30 | RXOVF29 | RXOVF28 | RXOVF27 | RXOVF26 | RXOVF25 | RXOVF24 |
| bit 15 | | | | | | | bit 8 |

| | | | | | | | |
|---------|---------|---------|---------|---------|---------|---------|---------|
| R/C-0 | R/C-0 | R/C-0 | R/C-0 | R/C-0 | R/C-0 | R/C-0 | R/C-0 |
| RXOVF23 | RXOVF22 | RXOVF21 | RXOVF20 | RXOVF19 | RXOVF18 | RXOVF17 | RXOVF16 |
| bit 7 | | | | | | | bit 0 |

| | |
|-------------------|--|
| Legend: | C = Writeable, but only '0' can be written to clear the bit |
| R = Readable bit | W = Writable bit U = Unimplemented bit, read as '0' |
| -n = Value at POR | '1' = Bit is set '0' = Bit is cleared x = Bit is unknown |

bit 15-0 **RXOVF<31:16>**: Receive Buffer n Overflow bits
 1 = Module attempted to write to a full buffer (set by module)
 0 = No overflow condition

dsPIC33FJ32GS406/606/608/610 and dsPIC33FJ64GS406/606/608/610

REGISTER 21-26: CxTRmnCON: ECANx TX/RX BUFFER mn CONTROL REGISTER (m = 0, 2, 4, 6; n = 1, 3, 5, 7)

| | | | | | | | |
|--------|--------|---------|--------|--------|--------|-------------|-------|
| R/W-0 | R-0 | R-0 | R-0 | R/W-0 | R/W-0 | R/W-0 | R/W-0 |
| TXENn | TXABTn | TXLARBn | TXERRn | TXREQn | RTRENn | TXnPRI<1:0> | |
| bit 15 | | | | | | | bit 8 |

| | | | | | | | |
|-------|-----------------------|------------------------|-----------------------|--------|--------|-------------|-------|
| R/W-0 | R-0 | R-0 | R-0 | R/W-0 | R/W-0 | R/W-0 | R/W-0 |
| TXENm | TXABTm ⁽¹⁾ | TXLARBm ⁽¹⁾ | TXERRm ⁽¹⁾ | TXREQm | RTRENm | TXmPRI<1:0> | |
| bit 7 | | | | | | | bit 0 |

Legend:

R = Readable bit W = Writable bit U = Unimplemented bit, read as '0'
 -n = Value at POR '1' = Bit is set '0' = Bit is cleared x = Bit is unknown

- bit 15-8 See Definition for bits 7-0, Controls Buffer n
- bit 7 **TXENm**: TX/RX Buffer Selection bit
 1 = Buffer TRBn is a transmit buffer
 0 = Buffer TRBn is a receive buffer
- bit 6 **TXABTm**: Message Aborted bit⁽¹⁾
 1 = Message was aborted
 0 = Message completed transmission successfully
- bit 5 **TXLARBm**: Message Lost Arbitration bit⁽¹⁾
 1 = Message lost arbitration while being sent
 0 = Message did not lose arbitration while being sent
- bit 4 **TXERRm**: Error Detected During Transmission bit⁽¹⁾
 1 = A bus error occurred while the message was being sent
 0 = A bus error did not occur while the message was being sent
- bit 3 **TXREQm**: Message Send request bit
 1 = Requests that a message be sent; the bit automatically clears when the message is successfully sent
 0 = Clears the bit to '0'; while set, requests a message abort
- bit 2 **RTRENm**: Auto-Remote Transmit Enable bit
 1 = When a remote transmit is received, TXREQm will be set
 0 = When a remote transmit is received, TXREQm will be unaffected
- bit 1-0 **TXmPRI<1:0>**: Message Transmission Priority bits
 11 = Highest message priority
 10 = High intermediate message priority
 01 = Low intermediate message priority
 00 = Lowest message priority

Note 1: This bit is cleared when TXREQm is set.

Note: The buffers, SID, EID, DLC, Data Field, and Receive Status registers are located in DMA RAM.

21.4 ECANx Message Buffers

ECANx message buffers are part of DMA RAM memory. They are not ECAN Special Function Registers. The user application must directly write into the DMA RAM area that is configured for ECANx message buffers. The location and size of the buffer area is defined by the user application.

BUFFER 21-1: ECANx MESSAGE BUFFER WORD 0

| | | | | | | | |
|--------|-----|-----|-------|-------|-------|-------|-------|
| U-0 | U-0 | U-0 | R/W-x | R/W-x | R/W-x | R/W-x | R/W-x |
| — | — | — | SID10 | SID9 | SID8 | SID7 | SID6 |
| bit 15 | | | | | | | bit 8 |

| | | | | | | | |
|-------|-------|-------|-------|-------|-------|-------|-------|
| R/W-x | R/W-x | R/W-x | R/W-x | R/W-x | R/W-x | R/W-x | R/W-x |
| SID5 | SID4 | SID3 | SID2 | SID1 | SID0 | SRR | IDE |
| bit 7 | | | | | | | bit 0 |

| | | | |
|-------------------|------------------|------------------------------------|--------------------|
| Legend: | | | |
| R = Readable bit | W = Writable bit | U = Unimplemented bit, read as '0' | |
| -n = Value at POR | '1' = Bit is set | '0' = Bit is cleared | x = Bit is unknown |

- bit 15-13 **Unimplemented:** Read as '0'
- bit 12-2 **SID<10:0>:** Standard Identifier bits
- bit 1 **SRR:** Substitute Remote Request bit
 - 1 = Message will request remote transmission
 - 0 = Normal message
- bit 0 **IDE:** Extended Identifier bit
 - 1 = Message will transmit extended identifier
 - 0 = Message will transmit standard identifier

BUFFER 21-2: ECANx MESSAGE BUFFER WORD 1

| | | | | | | | |
|--------|-----|-----|-----|-------|-------|-------|-------|
| U-0 | U-0 | U-0 | U-0 | R/W-x | R/W-x | R/W-x | R/W-x |
| — | — | — | — | EID17 | EID16 | EID15 | EID14 |
| bit 15 | | | | | | | bit 8 |

| | | | | | | | |
|-------|-------|-------|-------|-------|-------|-------|-------|
| R/W-x | R/W-x | R/W-x | R/W-x | R/W-x | R/W-x | R/W-x | R/W-x |
| EID13 | EID12 | EID11 | EID10 | EID9 | EID8 | EID7 | EID6 |
| bit 7 | | | | | | | bit 0 |

| | | | |
|-------------------|------------------|------------------------------------|--------------------|
| Legend: | | | |
| R = Readable bit | W = Writable bit | U = Unimplemented bit, read as '0' | |
| -n = Value at POR | '1' = Bit is set | '0' = Bit is cleared | x = Bit is unknown |

- bit 15-12 **Unimplemented:** Read as '0'
- bit 11-0 **EID<17:6>:** Extended Identifier bits

dsPIC33FJ32GS406/606/608/610 and dsPIC33FJ64GS406/606/608/610

BUFFER 21-3: ECANx MESSAGE BUFFER WORD 2

| | | | | | | | |
|--------|-------|-------|-------|-------|-------|-------|-------|
| R/W-x | R/W-x | R/W-x | R/W-x | R/W-x | R/W-x | R/W-x | R/W-x |
| EID5 | EID4 | EID3 | EID2 | EID1 | EID0 | RTR | RB1 |
| bit 15 | | | | | | | bit 8 |

| | | | | | | | |
|-------|-----|-----|-------|-------|-------|-------|-------|
| U-x | U-x | U-x | R/W-x | R/W-x | R/W-x | R/W-x | R/W-x |
| — | — | — | RB0 | DLC3 | DLC2 | DLC1 | DLC0 |
| bit 7 | | | | | | | bit 0 |

Legend:

R = Readable bit W = Writable bit U = Unimplemented bit, read as '0'
 -n = Value at POR '1' = Bit is set '0' = Bit is cleared x = Bit is unknown

- bit 15-10 **EID<5:0>**: Extended Identifier bits
- bit 9 **RTR**: Remote Transmission Request bit
 1 = Message will request remote transmission
 0 = Normal message
- bit 8 **RB1**: Reserved Bit 1
 User must set this bit to '0' per CAN protocol.
- bit 7-5 **Unimplemented**: Read as '0'
- bit 4 **RB0**: Reserved Bit 0
 User must set this bit to '0' per CAN protocol.
- bit 3-0 **DLC<3:0>**: Data Length Code bits

BUFFER 21-4: ECANx MESSAGE BUFFER WORD 3

| | | | | | | | |
|--------|-------|-------|-------|-------|-------|-------|-------|
| R/W-x | R/W-x | R/W-x | R/W-x | R/W-x | R/W-x | R/W-x | R/W-x |
| Byte 1 | | | | | | | |
| bit 15 | | | | | | | bit 8 |

| | | | | | | | |
|--------|-------|-------|-------|-------|-------|-------|-------|
| R/W-x | R/W-x | R/W-x | R/W-x | R/W-x | R/W-x | R/W-x | R/W-x |
| Byte 0 | | | | | | | |
| bit 7 | | | | | | | bit 0 |

Legend:

R = Readable bit W = Writable bit U = Unimplemented bit, read as '0'
 -n = Value at POR '1' = Bit is set '0' = Bit is cleared x = Bit is unknown

- bit 15-8 **Byte 1<15:8>**: ECANx Message Byte 0
- bit 7-0 **Byte 0<7:0>**: ECANx Message Byte 1

dsPIC33FJ32GS406/606/608/610 and dsPIC33FJ64GS406/606/608/610

BUFFER 21-5: ECANx MESSAGE BUFFER WORD 4

| | | | | | | | |
|--------|-------|-------|-------|-------|-------|-------|-------|
| R/W-x | R/W-x | R/W-x | R/W-x | R/W-x | R/W-x | R/W-x | R/W-x |
| Byte 3 | | | | | | | |
| bit 15 | | | | bit 8 | | | |

| | | | | | | | |
|--------|-------|-------|-------|-------|-------|-------|-------|
| R/W-x | R/W-x | R/W-x | R/W-x | R/W-x | R/W-x | R/W-x | R/W-x |
| Byte 2 | | | | | | | |
| bit 7 | | | | bit 0 | | | |

Legend:

R = Readable bit W = Writable bit U = Unimplemented bit, read as '0'
 -n = Value at POR '1' = Bit is set '0' = Bit is cleared x = Bit is unknown

bit 15-8 **Byte 3<15:8>**: ECANx Message Byte 3

bit 7-0 **Byte 2<7:0>**: ECANx Message Byte 2

BUFFER 21-6: ECANx MESSAGE BUFFER WORD 5

| | | | | | | | |
|--------|-------|-------|-------|-------|-------|-------|-------|
| R/W-x | R/W-x | R/W-x | R/W-x | R/W-x | R/W-x | R/W-x | R/W-x |
| Byte 5 | | | | | | | |
| bit 15 | | | | bit 8 | | | |

| | | | | | | | |
|--------|-------|-------|-------|-------|-------|-------|-------|
| R/W-x | R/W-x | R/W-x | R/W-x | R/W-x | R/W-x | R/W-x | R/W-x |
| Byte 4 | | | | | | | |
| bit 7 | | | | bit 0 | | | |

Legend:

R = Readable bit W = Writable bit U = Unimplemented bit, read as '0'
 -n = Value at POR '1' = Bit is set '0' = Bit is cleared x = Bit is unknown

bit 15-8 **Byte 5<15:8>**: ECANx Message Byte 5

bit 7-0 **Byte 4<7:0>**: ECANx Message Byte 4

dsPIC33FJ32GS406/606/608/610 and dsPIC33FJ64GS406/606/608/610

BUFFER 21-7: ECANx MESSAGE BUFFER WORD 6

| | | | | | | | |
|--------|-------|-------|-------|-------|-------|-------|-------|
| R/W-x | R/W-x | R/W-x | R/W-x | R/W-x | R/W-x | R/W-x | R/W-x |
| Byte 7 | | | | | | | |
| bit 15 | | | | bit 8 | | | |

| | | | | | | | |
|--------|-------|-------|-------|-------|-------|-------|-------|
| R/W-x | R/W-x | R/W-x | R/W-x | R/W-x | R/W-x | R/W-x | R/W-x |
| Byte 6 | | | | | | | |
| bit 7 | | | | bit 0 | | | |

Legend:

R = Readable bit W = Writable bit U = Unimplemented bit, read as '0'
 -n = Value at POR '1' = Bit is set '0' = Bit is cleared x = Bit is unknown

bit 15-8 **Byte 7<15:8>**: ECANx Message Byte 7

bit 7-0 **Byte 6<7:0>**: ECANx Message Byte 6

BUFFER 21-8: ECANx MESSAGE BUFFER WORD 7

| | | | | | | | |
|--------|-----|-----|----------------------------|-------|-------|-------|-------|
| U-0 | U-0 | U-0 | R/W-x | R/W-x | R/W-x | R/W-x | R/W-x |
| — | — | — | FILHIT<4:0> ⁽¹⁾ | | | | |
| bit 15 | | | | bit 8 | | | |

| | | | | | | | |
|-------|-----|-----|-----|-------|-----|-----|-----|
| U-0 | U-0 | U-0 | U-0 | U-0 | U-0 | U-0 | U-0 |
| — | — | — | — | — | — | — | — |
| bit 7 | | | | bit 0 | | | |

Legend:

R = Readable bit W = Writable bit U = Unimplemented bit, read as '0'
 -n = Value at POR '1' = Bit is set '0' = Bit is cleared x = Bit is unknown

bit 15-13 **Unimplemented:** Read as '0'

bit 12-8 **FILHIT<4:0>**: Filter Hit Code bits⁽¹⁾
 Encodes number of filter that resulted in writing this buffer.

bit 7-0 **Unimplemented:** Read as '0'

Note 1: Only written by module for receive buffers, unused for transmit buffers.

22.0 HIGH-SPEED, 10-BIT ANALOG-TO-DIGITAL CONVERTER (ADC)

Note 1: This data sheet summarizes the features of the dsPIC33FJ32GS406/606/608/610 and dsPIC33FJ64GS406/606/608/610 families of devices. It is not intended to be a comprehensive reference source. To complement the information in this data sheet, refer to **Section 44. “High-Speed 10-Bit Analog-to-Digital Converter (ADC)”** (DS70321) in the “dsPIC33F/PIC24H Family Reference Manual”, which is available from the Microchip web site (www.microchip.com).

2: Some registers and associated bits described in this section may not be available on all devices. Refer to **Section 4.0 “Memory Organization”** in this data sheet for device-specific register and bit information.

The dsPIC33FJ32GS406/606/608/610 and dsPIC33FJ64GS406/606/608/610 devices provide high-speed successive approximation Analog-to-Digital conversions to support applications such as AC/DC and DC/DC power converters.

22.1 Features Overview

The ADC module incorporates the following features:

- 10-Bit Resolution
- Unipolar Inputs
- Up to Two Successive Approximation Registers (SARs)
- Up to 24 External Input Channels
- Two Internal Analog Inputs
- Dedicated Result Register for each Analog Input
- ± 1 LSB Accuracy at 3.3V
- Single Supply Operation
- 4 Msps Conversion Rate at 3.3V (devices with two SARs)
- 2 Msps Conversion Rate at 3.3V (devices with one SAR)
- Low-Power CMOS Technology

22.2 Module Description

This ADC module is designed for applications that require low latency between the request for conversion and the resultant output data. Typical applications include:

- AC/DC Power Supplies
- DC/DC Converters
- Power Factor Correction (PFC)

This ADC works with the High-Speed PWM module in power control applications that require high-frequency control loops. This module can Sample-and-Convert two analog inputs in a 0.5 microsecond when two SARs are used. This small conversion delay reduces the “phase lag” between measurement and control system response.

Up to five inputs may be sampled at a time (four inputs from the dedicated sample and hold circuits and one from the shared sample and hold circuit). If multiple inputs request conversion, the ADC will convert them in a sequential manner, starting with the lowest order input.

This ADC design provides each pair of analog inputs (AN1, AN0), (AN3, AN2),..., the ability to specify its own trigger source out of a maximum of sixteen different trigger sources. This capability allows this ADC to Sample-and-Convert analog inputs that are associated with PWM generators operating on independent time bases.

The user application typically requires synchronization between analog data sampling and PWM output to the application circuit. The very high-speed operation of this ADC module allows “data on demand”.

In addition, several hardware features have been added to the peripheral interface to improve real-time performance in a typical DSP-based application.

- Result Alignment Options
- Automated Sampling
- External Conversion Start Control
- Two Internal Inputs to Monitor the INTREF and EXTREF Input Signals

Block diagrams of the ADC module for the family devices are shown in [Figure 22-1](#) through [Figure 22-4](#).

22.3 Module Functionality

The High-Speed, 10-Bit ADC is designed to support power conversion applications when used with the High-Speed PWM module. The ADC may have one or two SAR modules, depending on the device variant. If two SARs are present on a device, two conversions can be processed at a time, yielding 4 Msps conversion rate. If only one SAR is present on a device, only one conversion can be processed at a time, yielding 2 Msps conversion rate. The High-Speed, 10-Bit ADC produces two 10-bit conversion results in a 0.5 microsecond.

The ADC module supports up to 24 external analog inputs and two internal analog inputs. To monitor reference voltage, two internal inputs, AN24 and AN25, are connected to EXTREF and INTREF, respectively.

The analog reference voltage is defined as the device supply voltage (AV_{DD}/AV_{SS}).

The ADC module uses the following control and status registers:

- [ADCON: ADC Control Register](#)
- [ADSTAT: ADC Status Register](#)
- [ADBASE: ADC Base Register^{\(1,2\)}](#)
- [ADPCFG: ADC Port Configuration Register](#)
- [ADPCFG2: ADC Port Configuration Register 2](#)
- [ADCPC0: ADC Convert Pair Control Register 0](#)
- [ADCPC1: ADC Convert Pair Control Register 1](#)
- [ADCPC2: ADC Convert Pair Control Register 2](#)
- [ADCPC3: ADC Convert Pair Control Register 3](#)
- [ADCPC4: ADC Convert Pair Control Register 4](#)
- [ADCPC5: ADC Convert Pair Control Register 5](#)
- [ADCPC6: ADC Convert Pair Control Register 6\(2\)](#)

The ADCON register controls the operation of the ADC module. The ADSTAT register displays the status of the conversion processes. The ADPCFG registers configure the port pins as analog inputs or as digital I/O. The ADCPCx registers control the triggering of the ADC conversions. See [Register 22-1](#) through [Register 22-12](#) for detailed bit configurations.

| |
|---|
| <p>Note: A unique feature of the ADC module is its ability to sample inputs in an asynchronous manner. Individual sample and hold circuits can be triggered independently of each other.</p> |
|---|

FIGURE 22-1: ADC BLOCK DIAGRAM FOR dsPIC33FJ32GS406 AND dsPIC33FJ64GS406 DEVICES WITH ONE SAR



FIGURE 22-2: ADC BLOCK DIAGRAM FOR dsPIC33FJ32GS606 AND dsPIC33FJ64GS606 DEVICES WITH TWO SARs



FIGURE 22-3: ADC BLOCK DIAGRAM FOR dsPIC33FJ32GS608 AND dsPIC33FJ64GS608 DEVICES WITH TWO SARS



FIGURE 22-4: ADC BLOCK DIAGRAM FOR dsPIC33FJ32GS610 AND dsPIC33FJ64GS610 DEVICES WITH TWO SARs



REGISTER 22-1: ADON: ADC CONTROL REGISTER

| | | | | | | | |
|--------|-----|--------|------------------------|-----|--------|-----|---------------------|
| R/W-0 | U-0 | R/W-0 | R/W-0 | U-0 | R/W-0 | U-0 | R/W-0 |
| ADON | — | ADSIDL | SLOWCLK ⁽¹⁾ | — | GSWTRG | — | FORM ⁽¹⁾ |
| bit 15 | | | | | | | bit 8 |

| | | | | | | | |
|--------------------|------------------------|--------------------------|---------------------------|-----|--------------------------|-------|-------|
| R/W-0 | R/W-0 | R/W-0 | R/W-0 | U-0 | R/W-0 | R/W-1 | R/W-1 |
| EIE ⁽¹⁾ | ORDER ^(1,2) | SEQSAMP ^(1,2) | ASYNCNSAMP ⁽¹⁾ | — | ADCS<2:0> ⁽¹⁾ | | |
| bit 7 | | | | | | | bit 0 |

Legend:

| | | |
|-------------------|------------------|--|
| R = Readable bit | W = Writable bit | U = Unimplemented bit, read as '0' |
| -n = Value at POR | '1' = Bit is set | '0' = Bit is cleared x = Bit is unknown |

- bit 15 **ADON:** ADC Module Operating Mode bit
 1 = ADC module is operating
 0 = ADC module is off
- bit 14 **Unimplemented:** Read as '0'
- bit 13 **ADSIDL:** ADC Stop in Idle Mode bit
 1 = Discontinues module operation when device enters Idle mode
 0 = Continues module operation in Idle mode
- bit 12 **SLOWCLK:** Enable the Slow Clock Divider bit⁽¹⁾
 1 = ADC is clocked by the auxiliary PLL (ACLK)
 0 = ADC is clock by the primary PLL (Fvco)
- bit 11 **Unimplemented:** Read as '0'
- bit 10 **GSWTRG:** Global Software Trigger bit
 When this bit is set by the user, it will trigger conversions if selected by the TRGSRCx<4:0> bits in the ADCPCx registers. This bit must be cleared by the user prior to initiating another global trigger (i.e., this bit is not auto-clearing).
- bit 9 **Unimplemented:** Read as '0'
- bit 8 **FORM:** Data Output Format bit⁽¹⁾
 1 = Fractional (DOUT = dddd dddd dd00 0000)
 0 = Integer (DOUT = 0000 00dd dddd dddd)
- bit 7 **EIE:** Early Interrupt Enable bit⁽¹⁾
 1 = Interrupt is generated after first conversion is completed
 0 = Interrupt is generated after second conversion is completed
- bit 6 **ORDER:** Conversion Order bit^(1,2)
 1 = Odd numbered analog input is converted first, followed by conversion of even numbered input
 0 = Even numbered analog input is converted first, followed by conversion of odd numbered input
- bit 5 **SEQSAMP:** Sequential S&H Sampling Enable bit^(1,2)
 1 = Shared Sample and Hold (S&H) circuit is sampled at the start of the second conversion if ORDER = 0. If ORDER = 1, then the shared S&H is sampled at the start of the first conversion.
 0 = Shared S&H is sampled at the same time the dedicated S&H is sampled if the shared S&H is not currently busy with an existing conversion process. If the shared S&H is busy at the time the dedicated S&H is sampled, then the shared S&H will sample at the start of the new conversion cycle.
- bit 4 **ASYNCNSAMP:** Asynchronous Dedicated S&H Sampling Enable bit⁽¹⁾
 1 = The dedicated S&H is constantly sampling and then terminates sampling as soon as the trigger pulse is detected
 0 = The dedicated S&H starts sampling when the trigger event is detected and completes the sampling process in two ADC clock cycles

Note 1: This control bit can only be changed while the ADC is disabled (ADON = 0).

2: This control bit is only active on devices that have one SAR.

REGISTER 22-1: ADCON: ADC CONTROL REGISTER (CONTINUED)

bit 3 **Unimplemented:** Read as '0'

bit 2-0 **ADCS<2:0>:** Analog-to-Digital Conversion Clock Divider Select bits⁽¹⁾

- 111 = FADC/8
- 110 = FADC/7
- 101 = FADC/6
- 100 = FADC/5
- 011 = FADC/4 (default)
- 010 = FADC/3
- 001 = FADC/2
- 000 = FADC/1

Note 1: This control bit can only be changed while the ADC is disabled (ADON = 0).

2: This control bit is only active on devices that have one SAR.

REGISTER 22-2: ADSTAT: ADC STATUS REGISTER

| | | | | | | | |
|--------|-----|-----|-----------------------|-----------------------|-----------------------|----------------------|----------------------|
| U-0 | U-0 | U-0 | R/C-0, HS | R/C-0, HS | R/C-0, HS | R/C-0, HS | R/C-0, HS |
| — | — | — | P12RDY ⁽¹⁾ | P11RDY ⁽¹⁾ | P10RDY ⁽¹⁾ | P9RDY ⁽¹⁾ | P8RDY ⁽¹⁾ |
| bit 15 | | | | | | | bit 8 |

| | | | | | | | |
|----------------------|----------------------|----------------------|----------------------|----------------------|----------------------|----------------------|----------------------|
| R/C-0, HS | R/C-0, HS | R/C-0, HS | R/C-0, HS | R/C-0, HS | R/C-0, HS | R/C-0, HS | R/C-0, HS |
| P7RDY ⁽¹⁾ | P6RDY ⁽¹⁾ | P5RDY ⁽¹⁾ | P4RDY ⁽¹⁾ | P3RDY ⁽¹⁾ | P2RDY ⁽¹⁾ | P1RDY ⁽¹⁾ | P0RDY ⁽¹⁾ |
| bit 7 | | | | | | | bit 0 |

| | | |
|-------------------|-------------------|--|
| Legend: | C = Clearable bit | HS - Hardware Settable bit |
| R = Readable bit | W = Writable bit | U = Unimplemented bit, read as '0' |
| -n = Value at POR | '1' = Bit is set | '0' = Bit is cleared x = Bit is unknown |

- bit 15-13 **Unimplemented:** Read as '0'
- bit 6 **P12RDY:** Conversion Data for Pair 12 Ready bit⁽¹⁾
Bit is set when data is ready in buffer, cleared when a '0' is written to this bit.
- bit 5 **P11RDY:** Conversion Data for Pair 11 Ready bit⁽¹⁾
Bit is set when data is ready in buffer, cleared when a '0' is written to this bit.
- bit 4 **P10RDY:** Conversion Data for Pair 10 Ready bit⁽¹⁾
Bit is set when data is ready in buffer, cleared when a '0' is written to this bit.
- bit 3 **P9RDY:** Conversion Data for Pair 9 Ready bit⁽¹⁾
Bit is set when data is ready in buffer, cleared when a '0' is written to this bit.
- bit 2 **P8RDY:** Conversion Data for Pair 8 Ready bit⁽¹⁾
Bit is set when data is ready in buffer, cleared when a '0' is written to this bit.
- bit 1 **P7RDY:** Conversion Data for Pair 7 Ready bit⁽¹⁾
Bit is set when data is ready in buffer, cleared when a '0' is written to this bit.
- bit 6 **P6RDY:** Conversion Data for Pair 6 Ready bit⁽¹⁾
Bit is set when data is ready in buffer, cleared when a '0' is written to this bit.
- bit 5 **P5RDY:** Conversion Data for Pair 5 Ready bit⁽¹⁾
Bit is set when data is ready in buffer, cleared when a '0' is written to this bit.
- bit 4 **P4RDY:** Conversion Data for Pair 4 Ready bit⁽¹⁾
Bit is set when data is ready in buffer, cleared when a '0' is written to this bit.
- bit 3 **P3RDY:** Conversion Data for Pair 3 Ready bit⁽¹⁾
Bit is set when data is ready in buffer, cleared when a '0' is written to this bit.
- bit 2 **P2RDY:** Conversion Data for Pair 2 Ready bit⁽¹⁾
Bit is set when data is ready in buffer, cleared when a '0' is written to this bit.
- bit 1 **P1RDY:** Conversion Data for Pair 1 Ready bit⁽¹⁾
Bit is set when data is ready in buffer, cleared when a '0' is written to this bit.
- bit 0 **P0RDY:** Conversion Data for Pair 0 Ready bit⁽¹⁾
Bit is set when data is ready in buffer, cleared when a '0' is written to this bit.

Note 1: Not all PxRDY bits are available on all devices. See [Figure 22-1](#), [Figure 22-2](#), [Figure 22-3](#) and [Figure 22-4](#) for the available analog inputs.

dsPIC33FJ32GS406/606/608/610 and dsPIC33FJ64GS406/606/608/610

REGISTER 22-3: ADBASE: ADC BASE REGISTER^(1,2)

| | | | | | | | |
|--------------|-------|-------|-------|-------|-------|-------|-------|
| R/W-0 | R/W-0 | R/W-0 | R/W-0 | R/W-0 | R/W-0 | R/W-0 | R/W-0 |
| ADBASE<15:8> | | | | | | | |
| bit 15 | | | | | | | bit 8 |

| | | | | | | | |
|-------------|-------|-------|-------|-------|-------|-------|-------|
| R/W-0 | R/W-0 | R/W-0 | R/W-0 | R/W-0 | R/W-0 | R/W-0 | U-0 |
| ADBASE<7:1> | | | | | | | — |
| bit 7 | | | | | | | bit 0 |

Legend:

R = Readable bit

W = Writable bit

U = Unimplemented bit, read as '0'

-n = Value at POR

'1' = Bit is set

'0' = Bit is cleared

x = Bit is unknown

bit 15-1 **ADBASE<15:1>**: ADC Base Address bits

This register contains the base address of the user's ADC Interrupt Service Routine jump table. This register, when read, contains the sum of the ADBASE register contents and the encoded value of the PxRDY status bits.

The encoder logic provides the bit number of the highest priority PxRDY bits where P0RDY is the highest priority and P6RDY is the lowest priority.

bit 0 **Unimplemented**: Read as '0'

Note 1: The encoding results are shifted left two bits so bits 1-0 of the result are always zero.

Note 2: As an alternative to using the ADBASE register, the ADCP0-ADCP12 ADC pair conversion complete interrupts can be used to invoke Analog-to-Digital conversion completion routines for individual ADC input pairs.

dsPIC33FJ32GS406/606/608/610 and dsPIC33FJ64GS406/606/608/610

REGISTER 22-4: ADPCFG: ADC PORT CONFIGURATION REGISTER

| | | | | | | | |
|---------------------------|-------|-------|-------|-------|-------|-------|-------|
| R/W-0 | R/W-0 | R/W-0 | R/W-0 | R/W-0 | R/W-0 | R/W-0 | R/W-0 |
| PCFG<15:8> ⁽¹⁾ | | | | | | | |
| bit 15 | | | | bit 8 | | | |

| | | | | | | | |
|--------------------------|-------|-------|-------|-------|-------|-------|-------|
| R/W-0 | R/W-0 | R/W-0 | R/W-0 | R/W-0 | R/W-0 | R/W-0 | R/W-0 |
| PCFG<7:0> ⁽¹⁾ | | | | | | | |
| bit 7 | | | | bit 0 | | | |

Legend:

R = Readable bit W = Writable bit U = Unimplemented bit, read as '0'
 -n = Value at POR '1' = Bit is set '0' = Bit is cleared x = Bit is unknown

bit 15-0 **PCFG<15:0>**: ADC Port Configuration Control bits⁽¹⁾
 1 = Port pin in Digital mode, port read input is enabled; Analog-to-Digital input multiplexer is connected to AVSS
 0 = Port pin in Analog mode, port read input is disabled; Analog-to-Digital samples the pin voltage

Note 1: Not all PCFGx bits are available on all devices. See [Figure 22-1](#), [Figure 22-2](#), [Figure 22-3](#) and [Figure 22-4](#) for the available analog inputs (PCFGx = ANx, where x = 0-15).

REGISTER 22-5: ADPCFG2: ADC PORT CONFIGURATION REGISTER 2

| | | | | | | | |
|--------|-----|-----|-----|-------|-----|-----|-----|
| U-0 | U-0 | U-0 | U-0 | U-0 | U-0 | U-0 | U-0 |
| — | | | | | | | |
| bit 15 | | | | bit 8 | | | |

| | | | | | | | |
|----------------------------|-------|-------|-------|-------|-------|-------|-------|
| R/W-0 | R/W-0 | R/W-0 | R/W-0 | R/W-0 | R/W-0 | R/W-0 | R/W-0 |
| PCFG<23:16> ⁽¹⁾ | | | | | | | |
| bit 7 | | | | bit 0 | | | |

Legend:

R = Readable bit W = Writable bit U = Unimplemented bit, read as '0'
 -n = Value at POR '1' = Bit is set '0' = Bit is cleared x = Bit is unknown

bit 15-8 **Unimplemented:** Read as '0'
 bit 7-0 **PCFG<23:16>**: ADC Port Configuration Control bits⁽¹⁾
 1 = Port pin in Digital mode, port read input is enabled; Analog-to-Digital input multiplexer is connected to AVSS
 0 = Port pin in Analog mode, port read input is disabled; Analog-to-Digital samples the pin voltage

Note 1: Not all PCFGx bits are available on all devices. See [Figure 22-1](#), [Figure 22-2](#), [Figure 22-3](#) and [Figure 22-4](#) for the available analog inputs (PCFGx = ANx, where x can be 0 through 15).

dsPIC33FJ32GS406/606/608/610 and dsPIC33FJ64GS406/606/608/610

REGISTER 22-6: ADCPC0: ADC CONVERT PAIR CONTROL REGISTER 0

| | | | | | | | |
|--------|-------|--------|--------------|-------|-------|-------|-------|
| R/W-0 | R/W-0 | R/W-0 | R/W-0 | R/W-0 | R/W-0 | R/W-0 | R/W-0 |
| IRQEN1 | PEND1 | SWTRG1 | TRGSRC1<4:0> | | | | |
| bit 15 | | | | | | | bit 8 |

| | | | | | | | |
|--------|-------|--------|--------------|-------|-------|-------|-------|
| R/W-0 | R/W-0 | R/W-0 | R/W-0 | R/W-0 | R/W-0 | R/W-0 | R/W-0 |
| IRQEN0 | PEND0 | SWTRG0 | TRGSRC0<4:0> | | | | |
| bit 7 | | | | | | | bit 0 |

Legend:

R = Readable bit

W = Writable bit

U = Unimplemented bit, read as '0'

-n = Value at POR

'1' = Bit is set

'0' = Bit is cleared

x = Bit is unknown

bit 15 **IRQEN1:** Interrupt Request Enable 1 bit

1 = Enables IRQ generation when requested conversion of Channels AN3 and AN2 is completed
0 = IRQ is not generated

bit 14 **PEND1:** Pending Conversion Status 1 bit

1 = Conversion of Channels AN3 and AN2 is pending; set when selected trigger is asserted
0 = Conversion is complete

bit 13 **SWTRG1:** Software Trigger 1 bit

1 = Starts conversion of AN3 and AN2 (if selected in the TRGSRC bits)⁽¹⁾
This bit is automatically cleared by hardware when the PEND1 bit is set.
0 = Conversion has not started

Note 1: The trigger source must be set as a global software trigger prior to setting this bit to '1'. If other conversions are in progress, the conversion is performed when the conversion resources are available.

REGISTER 22-6: ADCPC0: ADC CONVERT PAIR CONTROL REGISTER 0 (CONTINUED)

- bit 12-8 **TRGSRC1<4:0>**: Trigger 1 Source Selection bits
Selects trigger source for conversion of Analog Channels AN3 and AN2.
11111 = Timer2 period match
11110 = PWM Generator 8 current-limit ADC trigger
11101 = PWM Generator 7 current-limit ADC trigger
11100 = PWM Generator 6 current-limit ADC trigger
11011 = PWM Generator 5 current-limit ADC trigger
11010 = PWM Generator 4 current-limit ADC trigger
11001 = PWM Generator 3 current-limit ADC trigger
11000 = PWM Generator 2 current-limit ADC trigger
10111 = PWM Generator 1 current-limit ADC trigger
10110 = PWM Generator 9 secondary trigger is selected
10101 = PWM Generator 8 secondary trigger is selected
10100 = PWM Generator 7 secondary trigger is selected
10011 = PWM Generator 6 secondary trigger is selected
10010 = PWM Generator 5 secondary trigger is selected
10001 = PWM Generator 4 secondary trigger is selected
10000 = PWM Generator 3 secondary trigger is selected
01111 = PWM Generator 2 secondary trigger is selected
01110 = PWM Generator 1 secondary trigger is selected
01101 = PWM secondary special event trigger is selected
01100 = Timer1 period match
01011 = PWM Generator 8 primary trigger is selected
01010 = PWM Generator 7 primary trigger is selected
01001 = PWM Generator 6 primary trigger is selected
01000 = PWM Generator 5 primary trigger is selected
00111 = PWM Generator 4 primary trigger selected
00110 = PWM Generator 3 primary trigger is selected
00101 = PWM Generator 2 primary trigger is selected
00100 = PWM Generator 1 primary trigger is selected
00011 = PWM special event trigger selected
00010 = Global software trigger is selected
00001 = Individual software trigger is selected
00000 = No conversion is enabled
- bit 7 **IRQEN0**: Interrupt Request Enable 0 bit
1 = Enables IRQ generation when requested conversion of Channels AN1 and AN0 is completed
0 = IRQ is not generated
- bit 6 **PEND0**: Pending Conversion Status 0 bit
1 = Conversion of Channels AN1 and AN0 is pending; set when selected trigger is asserted
0 = Conversion is complete
- bit 5 **SWTRG0**: Software Trigger 0 bit
1 = Starts conversion of AN1 and AN0 (if selected by TRGSRCx<4:0> bits)⁽¹⁾
This bit is automatically cleared by hardware when the PEND0 bit is set.
0 = Conversion has not started.

Note 1: The trigger source must be set as a global software trigger prior to setting this bit to '1'. If other conversions are in progress, the conversion is performed when the conversion resources are available.

REGISTER 22-6: ADCPC0: ADC CONVERT PAIR CONTROL REGISTER 0 (CONTINUED)

bit 4-0 **TRGSRC0<4:0>**: Trigger 0 Source Selection bits
Selects trigger source for conversion of Analog Channels AN1 and AN0.

- 11111 = Timer2 period match
- 11110 = PWM Generator 8 current-limit ADC trigger
- 11101 = PWM Generator 7 current-limit ADC trigger
- 11100 = PWM Generator 6 current-limit ADC trigger
- 11011 = PWM Generator 5 current-limit ADC trigger
- 11010 = PWM Generator 4 current-limit ADC trigger
- 11001 = PWM Generator 3 current-limit ADC trigger
- 11000 = PWM Generator 2 current-limit ADC trigger
- 10111 = PWM Generator 1 current-limit ADC trigger
- 10110 = PWM Generator 9 secondary trigger is selected
- 10101 = PWM Generator 8 secondary trigger is selected
- 10100 = PWM Generator 7 secondary trigger is selected
- 10011 = PWM Generator 6 secondary trigger is selected
- 10010 = PWM Generator 5 secondary trigger is selected
- 10001 = PWM Generator 4 secondary trigger is selected
- 10000 = PWM Generator 3 secondary trigger is selected
- 01111 = PWM Generator 2 secondary trigger is selected
- 01110 = PWM Generator 1 secondary trigger is selected
- 01101 = PWM secondary special event trigger is selected
- 01100 = Timer1 period match
- 01011 = PWM Generator 8 primary trigger is selected
- 01010 = PWM Generator 7 primary trigger is selected
- 01001 = PWM Generator 6 primary trigger is selected
- 01000 = PWM Generator 5 primary trigger is selected
- 00111 = PWM Generator 4 primary trigger is selected
- 00110 = PWM Generator 3 primary trigger is selected
- 00101 = PWM Generator 2 primary trigger is selected
- 00100 = PWM Generator 1 primary trigger is selected
- 00011 = PWM special event trigger is selected
- 00010 = Global software trigger is selected
- 00001 = Individual software trigger is selected
- 00000 = No conversion is enabled

Note 1: The trigger source must be set as a global software trigger prior to setting this bit to '1'. If other conversions are in progress, the conversion is performed when the conversion resources are available.

REGISTER 22-7: ADCPC1: ADC CONVERT PAIR CONTROL REGISTER 1

| | | | | | | | |
|--------|-------|--------|-----------------------------|-------|-------|-------|-------|
| R/W-0 | R/W-0 | R/W-0 | R/W-0 | R/W-0 | R/W-0 | R/W-0 | R/W-0 |
| IRQEN3 | PEND3 | SWTRG3 | TRGSRC3<4:0> ⁽¹⁾ | | | | |
| bit 15 | | | | | | | bit 8 |

| | | | | | | | |
|--------|-------|--------|--------------|-------|-------|-------|-------|
| R/W-0 | R/W-0 | R/W-0 | R/W-0 | R/W-0 | R/W-0 | R/W-0 | R/W-0 |
| IRQEN2 | PEND2 | SWTRG2 | TRGSRC2<4:0> | | | | |
| bit 7 | | | | | | | bit 0 |

Legend:

| | | |
|-------------------|------------------|--|
| R = Readable bit | W = Writable bit | U = Unimplemented bit, read as '0' |
| -n = Value at POR | '1' = Bit is set | '0' = Bit is cleared x = Bit is unknown |

- bit 15 **IRQEN3:** Interrupt Request Enable 3 bit
 1 = Enables IRQ generation when requested conversion of Channels AN7 and AN6 is completed
 0 = IRQ is not generated
- bit 14 **PEND3:** Pending Conversion Status 3 bit
 1 = Conversion of Channels AN7 and AN6 is pending; set when selected trigger is asserted
 0 = Conversion is complete
- bit 13 **SWTRG3:** Software Trigger 3 bit
 1 = Starts conversion of AN7 and AN6 (if selected in TRGSRC bits)⁽¹⁾
 This bit is automatically cleared by hardware when the PEND3 bit is set.
 0 = Conversion has not started

Note 1: The trigger source must be set as a global software trigger prior to setting this bit to '1'. If other conversions are in progress, the conversion is performed when the conversion resources are available.

REGISTER 22-7: ADCPC1: ADC CONVERT PAIR CONTROL REGISTER 1 (CONTINUED)

- bit 12-8 **TRGSRC3<4:0>**: Trigger 3 Source Selection bits⁽¹⁾
Selects trigger source for conversion of analog channels AN7 and AN6.
- 11111 = Timer2 period match
 - 11110 = PWM Generator 8 current-limit ADC trigger
 - 11101 = PWM Generator 7 current-limit ADC trigger
 - 11100 = PWM Generator 6 current-limit ADC trigger
 - 11011 = PWM Generator 5 current-limit ADC trigger
 - 11010 = PWM Generator 4 current-limit ADC trigger
 - 11001 = PWM Generator 3 current-limit ADC trigger
 - 11000 = PWM Generator 2 current-limit ADC trigger
 - 10111 = PWM Generator 1 current-limit ADC trigger
 - 10110 = PWM Generator 9 secondary trigger is selected
 - 10101 = PWM Generator 8 secondary trigger is selected
 - 10100 = PWM Generator 7 secondary trigger is selected
 - 10011 = PWM Generator 6 secondary trigger is selected
 - 10010 = PWM Generator 5 secondary trigger is selected
 - 10001 = PWM Generator 4 secondary trigger is selected
 - 10000 = PWM Generator 3 secondary trigger is selected
 - 01111 = PWM Generator 2 secondary trigger is selected
 - 01110 = PWM Generator 1 secondary trigger is selected
 - 01101 = PWM secondary special event trigger is selected
 - 01100 = Timer1 period match
 - 01011 = PWM Generator 8 primary trigger is selected
 - 01010 = PWM Generator 7 primary trigger is selected
 - 01001 = PWM Generator 6 primary trigger is selected
 - 01000 = PWM Generator 5 primary trigger is selected
 - 00111 = PWM Generator 4 primary trigger is selected
 - 00110 = PWM Generator 3 primary trigger is selected
 - 00101 = PWM Generator 2 primary trigger is selected
 - 00100 = PWM Generator 1 primary trigger is selected
 - 00011 = PWM special event trigger is selected
 - 00010 = Global software trigger is selected
 - 00001 = Individual software trigger is selected
 - 00000 = No conversion is enabled
- bit 7 **IRQEN2**: Interrupt Request Enable 2 bit
- 1 = Enables IRQ generation when requested conversion of Channels AN5 and AN4 is completed
 - 0 = IRQ is not generated
- bit 6 **PEND2**: Pending Conversion Status 2 bit
- 1 = Conversion of Channels AN5 and AN4 is pending; set when selected trigger is asserted
 - 0 = Conversion is complete
- bit 5 **SWTRG2**: Software Trigger 2 bit
- 1 = Starts conversion of AN5 and AN4 (if selected by TRGSRC bits)⁽¹⁾
 - This bit is automatically cleared by hardware when the PEND2 bit is set.
 - 0 = Conversion has not started

Note 1: The trigger source must be set as a global software trigger prior to setting this bit to '1'. If other conversions are in progress, the conversion is performed when the conversion resources are available.

REGISTER 22-7: ADCPC1: ADC CONVERT PAIR CONTROL REGISTER 1 (CONTINUED)

bit 4-0 **TRGSRC2<4:0>**: Trigger 2 Source Selection bits
Selects trigger source for conversion of Analog Channels AN5 and AN4.

- 11111 = Timer2 period match
- 11110 = PWM Generator 8 current-limit ADC trigger
- 11101 = PWM Generator 7 current-limit ADC trigger
- 11100 = PWM Generator 6 current-limit ADC trigger
- 11011 = PWM Generator 5 current-limit ADC trigger
- 11010 = PWM Generator 4 current-limit ADC trigger
- 11001 = PWM Generator 3 current-limit ADC trigger
- 11000 = PWM Generator 2 current-limit ADC trigger
- 10111 = PWM Generator 1 current-limit ADC trigger
- 10110 = PWM Generator 9 secondary trigger is selected
- 10101 = PWM Generator 8 secondary trigger is selected
- 10100 = PWM Generator 7 secondary trigger is selected
- 10011 = PWM Generator 6 secondary trigger is selected
- 10010 = PWM Generator 5 secondary trigger is selected
- 10001 = PWM Generator 4 secondary trigger selected
- 10000 = PWM Generator 3 secondary trigger is selected
- 01111 = PWM Generator 2 secondary trigger is selected
- 01110 = PWM Generator 1 secondary trigger is selected
- 01101 = PWM secondary special event trigger is selected
- 01100 = Timer1 period match
- 01011 = PWM Generator 8 primary trigger is selected
- 01010 = PWM Generator 7 primary trigger is selected
- 01001 = PWM Generator 6 primary trigger is selected
- 01000 = PWM Generator 5 primary trigger is selected
- 00111 = PWM Generator 4 primary trigger is selected
- 00110 = PWM Generator 3 primary trigger is selected
- 00101 = PWM Generator 2 primary trigger is selected
- 00100 = PWM Generator 1 primary trigger is selected
- 00011 = PWM special event trigger is selected
- 00010 = Global software trigger is selected
- 00001 = Individual software trigger is selected
- 00000 = No conversion is enabled

Note 1: The trigger source must be set as a global software trigger prior to setting this bit to '1'. If other conversions are in progress, the conversion is performed when the conversion resources are available.

dsPIC33FJ32GS406/606/608/610 and dsPIC33FJ64GS406/606/608/610

REGISTER 22-8: ADCPC2: ADC CONVERT PAIR CONTROL REGISTER 2

| | | | | | | | |
|--------|-------|--------|--------------|-------|-------|-------|-------|
| R/W-0 | R/W-0 | R/W-0 | R/W-0 | R/W-0 | R/W-0 | R/W-0 | R/W-0 |
| IRQEN5 | PEND5 | SWTRG5 | TRGSRC5<4:0> | | | | |
| bit 15 | | | | | | | bit 8 |

| | | | | | | | |
|--------|-------|--------|--------------|-------|-------|-------|-------|
| R/W-0 | R/W-0 | R/W-0 | R/W-0 | R/W-0 | R/W-0 | R/W-0 | R/W-0 |
| IRQEN4 | PEND4 | SWTRG4 | TRGSRC4<4:0> | | | | |
| bit 7 | | | | | | | bit 0 |

Legend:

| | | |
|-------------------|------------------|--|
| R = Readable bit | W = Writable bit | U = Unimplemented bit, read as '0' |
| -n = Value at POR | '1' = Bit is set | '0' = Bit is cleared x = Bit is unknown |

- bit 15 **IRQEN5:** Interrupt Request Enable 5 bit
 1 = Enables IRQ generation when requested conversion of Channels AN11 and AN10 is completed
 0 = IRQ is not generated
- bit 14 **PEND5:** Pending Conversion Status 5 bit
 1 = Conversion of Channels AN11 and AN10 is pending; set when selected trigger is asserted
 0 = Conversion is complete
- bit 13 **SWTRG5:** Software Trigger 5 bit
 1 = Starts conversion of AN11 and AN10 (if selected in TRGSRC bits)⁽¹⁾
 This bit is automatically cleared by hardware when the PEND5 bit is set.
 0 = Conversion has not started

Note 1: The trigger source must be set as a global software trigger prior to setting this bit to '1'. If other conversions are in progress, the conversion is performed when the conversion resources are available.

REGISTER 22-8: ADCPC2: ADC CONVERT PAIR CONTROL REGISTER 2 (CONTINUED)

- bit 12-8 **TRGSRC5<4:0>**: Trigger 5 Source Selection bits
Selects trigger source for conversion of Analog Channels AN11 and AN10.
11111 = Timer2 period match
11110 = PWM Generator 8 current-limit ADC trigger
11101 = PWM Generator 7 current-limit ADC trigger
11100 = PWM Generator 6 current-limit ADC trigger
11011 = PWM Generator 5 current-limit ADC trigger
11010 = PWM Generator 4 current-limit ADC trigger
11001 = PWM Generator 3 current-limit ADC trigger
11000 = PWM Generator 2 current-limit ADC trigger
10111 = PWM Generator 1 current-limit ADC trigger
10110 = PWM Generator 9 secondary trigger selected
10101 = PWM Generator 8 secondary trigger selected
10100 = PWM Generator 7 secondary trigger selected
10011 = PWM Generator 6 secondary trigger selected
10010 = PWM Generator 5 secondary trigger selected
10001 = PWM Generator 4 secondary trigger selected
10000 = PWM Generator 3 secondary trigger selected
01111 = PWM Generator 2 secondary trigger selected
01110 = PWM Generator 1 secondary trigger selected
01101 = PWM secondary special event trigger selected
01100 = Timer1 period match
01011 = PWM Generator 8 primary trigger selected
01010 = PWM Generator 7 primary trigger selected
01001 = PWM Generator 6 primary trigger selected
01000 = PWM Generator 5 primary trigger selected
00111 = PWM Generator 4 primary trigger selected
00110 = PWM Generator 3 primary trigger selected
00101 = PWM Generator 2 primary trigger selected
00100 = PWM Generator 1 primary trigger selected
00011 = PWM special event trigger selected
00010 = Global software trigger selected
00001 = Individual software trigger selected
00000 = No conversion is enabled
- bit 7 **IRQEN4**: Interrupt Request Enable 4 bit
1 = Enables IRQ generation when requested conversion of Channels AN9 and AN8 is completed
0 = IRQ is not generated
- bit 6 **PEND4**: Pending Conversion Status 4 bit
1 = Conversion of Channels AN9 and AN8 is pending; set when selected trigger is asserted
0 = Conversion is complete
- bit 5 **SWTRG4**: Software Trigger4 bit
1 = Starts conversion of AN9 and AN8 (if selected by TRGSRC bits)⁽¹⁾
This bit is automatically cleared by hardware when the PEND4 bit is set.
0 = Conversion has not started

Note 1: The trigger source must be set as a global software trigger prior to setting this bit to '1'. If other conversions are in progress, the conversion is performed when the conversion resources are available.

REGISTER 22-8: ADCPC2: ADC CONVERT PAIR CONTROL REGISTER 2 (CONTINUED)

bit 4-0 **TRGSRC4<4:0>**: Trigger 4 Source Selection bits
Selects trigger source for conversion of Analog Channels AN9 and AN8.

- 11111 = Timer2 period match
- 11110 = PWM Generator 8 current-limit ADC trigger
- 11101 = PWM Generator 7 current-limit ADC trigger
- 11100 = PWM Generator 6 current-limit ADC trigger
- 11011 = PWM Generator 5 current-limit ADC trigger
- 11010 = PWM Generator 4 current-limit ADC trigger
- 11001 = PWM Generator 3 current-limit ADC trigger
- 11000 = PWM Generator 2 current-limit ADC trigger
- 10111 = PWM Generator 1 current-limit ADC trigger
- 10110 = PWM Generator 9 secondary trigger selected
- 10101 = PWM Generator 8 secondary trigger selected
- 10100 = PWM Generator 7 secondary trigger selected
- 10011 = PWM Generator 6 secondary trigger selected
- 10010 = PWM Generator 5 secondary trigger selected
- 10001 = PWM Generator 4 secondary trigger selected
- 10000 = PWM Generator 3 secondary trigger selected
- 01111 = PWM Generator 2 secondary trigger selected
- 01110 = PWM Generator 1 secondary trigger selected
- 01101 = PWM secondary special event trigger selected
- 01100 = Timer1 period match
- 01011 = PWM Generator 8 primary trigger selected
- 01010 = PWM Generator 7 primary trigger selected
- 01001 = PWM Generator 6 primary trigger selected
- 01000 = PWM Generator 5 primary trigger selected
- 00111 = PWM Generator 4 primary trigger selected
- 00110 = PWM Generator 3 primary trigger selected
- 00101 = PWM Generator 2 primary trigger selected
- 00100 = PWM Generator 1 primary trigger selected
- 00011 = PWM special event trigger selected
- 00010 = Global software trigger selected
- 00001 = Individual software trigger selected
- 00000 = No conversion is enabled

Note 1: The trigger source must be set as a global software trigger prior to setting this bit to '1'. If other conversions are in progress, the conversion is performed when the conversion resources are available.

dsPIC33FJ32GS406/606/608/610 and dsPIC33FJ64GS406/606/608/610

REGISTER 22-9: ADCPC3: ADC CONVERT PAIR CONTROL REGISTER 3

| | | | | | | | |
|--------|-------|--------|--------------|-------|-------|-------|-------|
| R/W-0 | R/W-0 | R/W-0 | R/W-0 | R/W-0 | R/W-0 | R/W-0 | R/W-0 |
| IRQEN7 | PEND7 | SWTRG7 | TRGSRC7<4:0> | | | | |
| bit 15 | | | | | | | bit 8 |

| | | | | | | | |
|--------|-------|--------|--------------|-------|-------|-------|-------|
| R/W-0 | R/W-0 | R/W-0 | R/W-0 | R/W-0 | R/W-0 | R/W-0 | R/W-0 |
| IRQEN6 | PEND6 | SWTRG6 | TRGSRC6<4:0> | | | | |
| bit 7 | | | | | | | bit 0 |

Legend:

R = Readable bit

W = Writable bit

U = Unimplemented bit, read as '0'

-n = Value at POR

'1' = Bit is set

'0' = Bit is cleared

x = Bit is unknown

- bit 15 **IRQEN7:** Interrupt Request Enable 7 bit
 1 = Enables IRQ generation when requested conversion of Channels AN15 and AN14 is completed
 0 = IRQ is not generated
- bit 14 **PEND7:** Pending Conversion Status 7 bit
 1 = Conversion of Channels AN15 and AN14 is pending; set when selected trigger is asserted
 0 = Conversion is complete
- bit 13 **SWTRG7:** Software Trigger 7 bit
 1 = Starts conversion of AN15 and AN14 (if selected in TRGSRC bits)⁽¹⁾
 This bit is automatically cleared by hardware when the PEND7 bit is set.
 0 = Conversion has not started

Note 1: The trigger source must be set as a global software trigger prior to setting this bit to '1'. If other conversions are in progress, the conversion is performed when the conversion resources are available.

REGISTER 22-9: ADCPC3: ADC CONVERT PAIR CONTROL REGISTER 3 (CONTINUED)

- bit 12-8 **TRGSRC7<4:0>**: Trigger 7 Source Selection bits
Selects trigger source for conversion of Analog Channels AN15 and 14.
11111 = Timer2 period match
11110 = PWM Generator 8 current-limit ADC trigger
11101 = PWM Generator 7 current-limit ADC trigger
11100 = PWM Generator 6 current-limit ADC trigger
11011 = PWM Generator 5 current-limit ADC trigger
11010 = PWM Generator 4 current-limit ADC trigger
11001 = PWM Generator 3 current-limit ADC trigger
11000 = PWM Generator 2 current-limit ADC trigger
10111 = PWM Generator 1 current-limit ADC trigger
10110 = PWM Generator 9 secondary trigger selected
10101 = PWM Generator 8 secondary trigger selected
10100 = PWM Generator 7 secondary trigger selected
10011 = PWM Generator 6 secondary trigger selected
10010 = PWM Generator 5 secondary trigger selected
10001 = PWM Generator 4 secondary trigger selected
10000 = PWM Generator 3 secondary trigger selected
01111 = PWM Generator 2 secondary trigger selected
01110 = PWM Generator 1 secondary trigger selected
01101 = PWM secondary special event trigger selected
01100 = Timer1 period match
01011 = PWM Generator 8 primary trigger selected
01010 = PWM Generator 7 primary trigger selected
01001 = PWM Generator 6 primary trigger selected
01000 = PWM Generator 5 primary trigger selected
00111 = PWM Generator 4 primary trigger selected
00110 = PWM Generator 3 primary trigger selected
00101 = PWM Generator 2 primary trigger selected
00100 = PWM Generator 1 primary trigger selected
00011 = PWM special event trigger selected
00010 = Global software trigger selected
00001 = Individual software trigger selected
00000 = No conversion is enabled
- bit 7 **IRQEN6**: Interrupt Request Enable 6 bit
1 = Enables IRQ generation when requested conversion of Channels AN13 and AN12 is completed
0 = IRQ is not generated
- bit 6 **PEND6**: Pending Conversion Status 6 bit
1 = Conversion of Channels AN13 and AN12 is pending; set when selected trigger is asserted
0 = Conversion is complete
- bit 5 **SWTRG6**: Software Trigger 6 bit
1 = Starts conversion of AN13 and AN12 (if selected by TRGSRC bits)⁽¹⁾
This bit is automatically cleared by hardware when the PEND6 bit is set.
0 = Conversion has not started

Note 1: The trigger source must be set as a global software trigger prior to setting this bit to '1'. If other conversions are in progress, the conversion is performed when the conversion resources are available.

REGISTER 22-9: ADCPC3: ADC CONVERT PAIR CONTROL REGISTER 3 (CONTINUED)

bit 4-0 **TRGSRC6<4:0>**: Trigger 6 Source Selection bits
Selects trigger source for conversion of Analog Channels AN13 and AN12.

- 11111 = Timer2 period match
- 11110 = PWM Generator 8 current-limit ADC trigger
- 11101 = PWM Generator 7 current-limit ADC trigger
- 11100 = PWM Generator 6 current-limit ADC trigger
- 11011 = PWM Generator 5 current-limit ADC trigger
- 11010 = PWM Generator 4 current-limit ADC trigger
- 11001 = PWM Generator 3 current-limit ADC trigger
- 11000 = PWM Generator 2 current-limit ADC trigger
- 10111 = PWM Generator 1 current-limit ADC trigger
- 10110 = PWM Generator 9 secondary trigger selected
- 10101 = PWM Generator 8 secondary trigger selected
- 10100 = PWM Generator 7 secondary trigger selected
- 10011 = PWM Generator 6 secondary trigger selected
- 10010 = PWM Generator 5 secondary trigger selected
- 10001 = PWM Generator 4 secondary trigger selected
- 10000 = PWM Generator 3 secondary trigger selected
- 01111 = PWM Generator 2 secondary trigger selected
- 01110 = PWM Generator 1 secondary trigger selected
- 01101 = PWM secondary special event trigger selected
- 01100 = Timer1 period match
- 01011 = PWM Generator 8 primary trigger selected
- 01010 = PWM Generator 7 primary trigger selected
- 01001 = PWM Generator 6 primary trigger selected
- 01000 = PWM Generator 5 primary trigger selected
- 00111 = PWM Generator 4 primary trigger selected
- 00110 = PWM Generator 3 primary trigger selected
- 00101 = PWM Generator 2 primary trigger selected
- 00100 = PWM Generator 1 primary trigger selected
- 00011 = PWM special event trigger selected
- 00010 = Global software trigger selected
- 00001 = Individual software trigger selected
- 00000 = No conversion is enabled

Note 1: The trigger source must be set as a global software trigger prior to setting this bit to '1'. If other conversions are in progress, the conversion is performed when the conversion resources are available.

dsPIC33FJ32GS406/606/608/610 and dsPIC33FJ64GS406/606/608/610

REGISTER 22-10: ADCPC4: ADC CONVERT PAIR CONTROL REGISTER 4

| | | | | | | | |
|--------|-------|--------|--------------|-------|-------|-------|-------|
| R/W-0 | R/W-0 | R/W-0 | R/W-0 | R/W-0 | R/W-0 | R/W-0 | R/W-0 |
| IRQEN9 | PEND9 | SWTRG9 | TRGSRC9<4:0> | | | | |
| bit 15 | | | | | | | bit 8 |

| | | | | | | | |
|--------|-------|--------|--------------|-------|-------|-------|-------|
| R/W-0 | R/W-0 | R/W-0 | R/W-0 | R/W-0 | R/W-0 | R/W-0 | R/W-0 |
| IRQEN8 | PEND8 | SWTRG8 | TRGSRC8<4:0> | | | | |
| bit 7 | | | | | | | bit 0 |

Legend:

R = Readable bit W = Writable bit U = Unimplemented bit, read as '0'
-n = Value at POR '1' = Bit is set '0' = Bit is cleared x = Bit is unknown

- bit 15 **IRQEN9:** Interrupt Request Enable 9 bit
1 = Enable IRQ generation when requested conversion of channels AN19 and AN18 is completed
0 = IRQ is not generated
- bit 14 **PEND9:** Pending Conversion Status 9 bit
1 = Conversion of channels AN19 and AN18 is pending; set when selected trigger is asserted
0 = Conversion is complete
- bit 13 **SWTRG9:** Software Trigger 9 bit
1 = Start conversion of AN19 and AN18 (if selected in TRGSRC bits)⁽¹⁾
This bit is automatically cleared by hardware when the PEND9 bit is set.
0 = Conversion is not started

Note 1: The trigger source must be set as a global software trigger prior to setting this bit to '1'. If other conversions are in progress, the conversion is performed when the conversion resources are available.

REGISTER 22-10: ADCPC4: ADC CONVERT PAIR CONTROL REGISTER 4 (CONTINUED)

- bit 12-8 **TRGSRC9<4:0>**: Trigger 9 Source Selection bits
Selects trigger source for conversion of analog channels AN19 and AN18.
11111 = Timer2 period match
11110 = PWM Generator 8 current-limit ADC trigger
11101 = PWM Generator 7 current-limit ADC trigger
11100 = PWM Generator 6 current-limit ADC trigger
11011 = PWM Generator 5 current-limit ADC trigger
11010 = PWM Generator 4 current-limit ADC trigger
11001 = PWM Generator 3 current-limit ADC trigger
11000 = PWM Generator 2 current-limit ADC trigger
10111 = PWM Generator 1 current-limit ADC trigger
10110 = PWM Generator 9 secondary trigger selected
10101 = PWM Generator 8 secondary trigger selected
10100 = PWM Generator 7 secondary trigger selected
10011 = PWM Generator 6 secondary trigger selected
10010 = PWM Generator 5 secondary trigger selected
10001 = PWM Generator 4 secondary trigger selected
10000 = PWM Generator 3 secondary trigger selected
01111 = PWM Generator 2 secondary trigger selected
01110 = PWM Generator 1 secondary trigger selected
01101 = PWM secondary special event trigger selected
01100 = Timer1 period match
01011 = PWM Generator 8 primary trigger selected
01010 = PWM Generator 7 primary trigger selected
01001 = PWM Generator 6 primary trigger selected
01000 = PWM Generator 5 primary trigger selected
00111 = PWM Generator 4 primary trigger selected
00110 = PWM Generator 3 primary trigger selected
00101 = PWM Generator 2 primary trigger selected
00100 = PWM Generator 1 primary trigger selected
00011 = PWM special event trigger selected
00010 = Global software trigger selected
00001 = Individual software trigger selected
00000 = No conversion is enabled
- bit 7 **IRQEN8**: Interrupt Request Enable 8 bit
1 = Enables IRQ generation when requested conversion of Channels AN17 and AN16 is completed
0 = IRQ is not generated
- bit 6 **PEND8**: Pending Conversion Status 8 bit
1 = Conversion of Channels AN17 and AN16 is pending; set when selected trigger is asserted
0 = Conversion is complete
- bit 5 **SWTRG8**: Software Trigger 8 bit
1 = Starts conversion of AN17 and AN16 (if selected by TRGSRC bits)⁽¹⁾
This bit is automatically cleared by hardware when the PEND8 bit is set.
0 = Conversion has not started

Note 1: The trigger source must be set as a global software trigger prior to setting this bit to '1'. If other conversions are in progress, the conversion is performed when the conversion resources are available.

REGISTER 22-10: ADCPC4: ADC CONVERT PAIR CONTROL REGISTER 4 (CONTINUED)

bit 4-0 **TRGSRC8<4:0>**: Trigger 8 Source Selection bits
Selects trigger source for conversion of Analog Channels AN17 and AN16.

- 11111 = Timer2 period match
- 11110 = PWM Generator 8 current-limit ADC trigger
- 11101 = PWM Generator 7 current-limit ADC trigger
- 11100 = PWM Generator 6 current-limit ADC trigger
- 11011 = PWM Generator 5 current-limit ADC trigger
- 11010 = PWM Generator 4 current-limit ADC trigger
- 11001 = PWM Generator 3 current-limit ADC trigger
- 11000 = PWM Generator 2 current-limit ADC trigger
- 10111 = PWM Generator 1 current-limit ADC trigger
- 10110 = PWM Generator 9 secondary trigger selected
- 10101 = PWM Generator 8 secondary trigger selected
- 10100 = PWM Generator 7 secondary trigger selected
- 10011 = PWM Generator 6 secondary trigger selected
- 10010 = PWM Generator 5 secondary trigger selected
- 10001 = PWM Generator 4 secondary trigger selected
- 10000 = PWM Generator 3 secondary trigger selected
- 01111 = PWM Generator 2 secondary trigger selected
- 01110 = PWM Generator 1 secondary trigger selected
- 01101 = PWM secondary special event trigger selected
- 01100 = Timer1 period match
- 01011 = PWM Generator 8 primary trigger selected
- 01010 = PWM Generator 7 primary trigger selected
- 01001 = PWM Generator 6 primary trigger selected
- 01000 = PWM Generator 5 primary trigger selected
- 00111 = PWM Generator 4 primary trigger selected
- 00110 = PWM Generator 3 primary trigger selected
- 00101 = PWM Generator 2 primary trigger selected
- 00100 = PWM Generator 1 primary trigger selected
- 00011 = PWM special event trigger selected
- 00010 = Global software trigger selected
- 00001 = Individual software trigger selected
- 00000 = No conversion is enabled

Note 1: The trigger source must be set as a global software trigger prior to setting this bit to '1'. If other conversions are in progress, the conversion is performed when the conversion resources are available.

REGISTER 22-11: ADCPC5: ADC CONVERT PAIR CONTROL REGISTER 5

| | | | | | | | |
|---------|--------|---------|---------------|-------|-------|-------|-------|
| R/W-0 | R/W-0 | R/W-0 | R/W-0 | R/W-0 | R/W-0 | R/W-0 | R/W-0 |
| IRQEN11 | PEND11 | SWTRG11 | TRGSRC11<4:0> | | | | |
| bit 15 | | | | | | | bit 8 |

| | | | | | | | |
|---------|--------|---------|---------------|-------|-------|-------|-------|
| R/W-0 | R/W-0 | R/W-0 | R/W-0 | R/W-0 | R/W-0 | R/W-0 | R/W-0 |
| IRQEN10 | PEND10 | SWTRG10 | TRGSRC10<4:0> | | | | |
| bit 7 | | | | | | | bit 0 |

Legend:

| | | |
|-------------------|------------------|--|
| R = Readable bit | W = Writable bit | U = Unimplemented bit, read as '0' |
| -n = Value at POR | '1' = Bit is set | '0' = Bit is cleared x = Bit is unknown |

- bit 15 **IRQEN11:** Interrupt Request Enable 11 bit
 1 = Enables IRQ generation when requested conversion of Channels AN23 and AN22 is completed
 0 = IRQ is not generated
- bit 14 **PEND11:** Pending Conversion Status 11 bit
 1 = Conversion of Channels AN23 and AN22 is pending; set when selected trigger is asserted
 0 = Conversion is complete
- bit 13 **SWTRG11:** Software Trigger 11 bit
 1 = Starts conversion of AN23 and AN22 (if selected in TRGSRC bits)⁽¹⁾
 This bit is automatically cleared by hardware when the PEND11 bit is set.
 0 = Conversion is not started

Note 1: The trigger source must be set as a global software trigger prior to setting this bit to '1'. If other conversions are in progress, the conversion is performed when the conversion resources are available.

REGISTER 22-11: ADCPC5: ADC CONVERT PAIR CONTROL REGISTER 5 (CONTINUED)

- bit 12-8 **TRGSRC11<4:0>**: Trigger 11 Source Selection bits
Selects trigger source for conversion of analog channels AN23 and AN22.
11111 = Timer2 period match
11110 = PWM Generator 8 current-limit ADC trigger
11101 = PWM Generator 7 current-limit ADC trigger
11100 = PWM Generator 6 current-limit ADC trigger
11011 = PWM Generator 5 current-limit ADC trigger
11010 = PWM Generator 4 current-limit ADC trigger
11001 = PWM Generator 3 current-limit ADC trigger
11000 = PWM Generator 2 current-limit ADC trigger
10111 = PWM Generator 1 current-limit ADC trigger
10110 = PWM Generator 9 secondary trigger selected
10101 = PWM Generator 8 secondary trigger selected
10100 = PWM Generator 7 secondary trigger selected
10011 = PWM Generator 6 secondary trigger selected
10010 = PWM Generator 5 secondary trigger selected
10001 = PWM Generator 4 secondary trigger selected
10000 = PWM Generator 3 secondary trigger selected
01111 = PWM Generator 2 secondary trigger selected
01110 = PWM Generator 1 secondary trigger selected
01101 = PWM secondary special event trigger selected
01100 = Timer1 period match
01011 = PWM Generator 8 primary trigger selected
01010 = PWM Generator 7 primary trigger selected
01001 = PWM Generator 6 primary trigger selected
01000 = PWM Generator 5 primary trigger selected
00111 = PWM Generator 4 primary trigger selected
00110 = PWM Generator 3 primary trigger selected
00101 = PWM Generator 2 primary trigger selected
00100 = PWM Generator 1 primary trigger selected
00011 = PWM special event trigger selected
00010 = Global software trigger selected
00001 = Individual software trigger selected
00000 = No conversion is enabled
- bit 7 **IRQEN10**: Interrupt Request Enable 10 bit
1 = Enables IRQ generation when requested conversion of Channels AN21 and AN20 is completed
0 = IRQ is not generated
- bit 6 **PEND10**: Pending Conversion Status 10 bit
1 = Conversion of Channels AN21 and AN20 is pending; set when selected trigger is asserted
0 = Conversion is complete
- bit 5 **SWTRG10**: Software Trigger 10 bit
1 = Starts conversion of AN21 and AN20 (if selected by TRGSRC bits)⁽¹⁾
This bit is automatically cleared by hardware when the PEND10 bit is set.
0 = Conversion has not started

Note 1: The trigger source must be set as a global software trigger prior to setting this bit to '1'. If other conversions are in progress, the conversion is performed when the conversion resources are available.

REGISTER 22-11: ADCPC5: ADC CONVERT PAIR CONTROL REGISTER 5 (CONTINUED)

bit 4-0 **TRGSRC10<4:0>**: Trigger 10 Source Selection bits
Selects trigger source for conversion of analog channels AN21 and AN20.

- 11111 = Timer2 period match
- 11110 = PWM Generator 8 current-limit ADC trigger
- 11101 = PWM Generator 7 current-limit ADC trigger
- 11100 = PWM Generator 6 current-limit ADC trigger
- 11011 = PWM Generator 5 current-limit ADC trigger
- 11010 = PWM Generator 4 current-limit ADC trigger
- 11001 = PWM Generator 3 current-limit ADC trigger
- 11000 = PWM Generator 2 current-limit ADC trigger
- 10111 = PWM Generator 1 current-limit ADC trigger
- 10110 = PWM Generator 9 secondary trigger selected
- 10101 = PWM Generator 8 secondary trigger selected
- 10100 = PWM Generator 7 secondary trigger selected
- 10011 = PWM Generator 6 secondary trigger selected
- 10010 = PWM Generator 5 secondary trigger selected
- 10001 = PWM Generator 4 secondary trigger selected
- 10000 = PWM Generator 3 secondary trigger selected
- 01111 = PWM Generator 2 secondary trigger selected
- 01110 = PWM Generator 1 secondary trigger selected
- 01101 = PWM secondary special event trigger selected
- 01100 = Timer1 period match
- 01011 = PWM Generator 8 primary trigger selected
- 01010 = PWM Generator 7 primary trigger selected
- 01001 = PWM Generator 6 primary trigger selected
- 01000 = PWM Generator 5 primary trigger selected
- 00111 = PWM Generator 4 primary trigger selected
- 00110 = PWM Generator 3 primary trigger selected
- 00101 = PWM Generator 2 primary trigger selected
- 00100 = PWM Generator 1 primary trigger selected
- 00011 = PWM special event trigger selected
- 00010 = Global software trigger selected
- 00001 = Individual software trigger selected
- 00000 = No conversion enabled

Note 1: The trigger source must be set as a global software trigger prior to setting this bit to '1'. If other conversions are in progress, the conversion is performed when the conversion resources are available.

dsPIC33FJ32GS406/606/608/610 and dsPIC33FJ64GS406/606/608/610

REGISTER 22-12: ADCPC6: ADC CONVERT PAIR CONTROL REGISTER 6⁽²⁾

| | | | | | | | |
|--------|-----|-----|-----|-----|-----|-----|-------|
| U-0 | U-0 | U-0 | U-0 | U-0 | U-0 | U-0 | U-0 |
| — | — | — | — | — | — | — | — |
| bit 15 | | | | | | | bit 8 |

| | | | | | | | |
|---------|--------|---------|---------------|-------|-------|-------|-------|
| R/W-0 | R/W-0 | R/W-0 | R/W-0 | R/W-0 | R/W-0 | R/W-0 | R/W-0 |
| IRQEN12 | PEND12 | SWTRG12 | TRGSRC12<4:0> | | | | |
| bit 7 | | | | | | | bit 0 |

Legend:

| | | |
|-------------------|------------------|--|
| R = Readable bit | W = Writable bit | U = Unimplemented bit, read as '0' |
| -n = Value at POR | '1' = Bit is set | '0' = Bit is cleared x = Bit is unknown |

bit 15-8 **Unimplemented:** Read as '0'

bit 7 **IRQEN12:** Interrupt Request Enable 12 bit

1 = Enables IRQ generation when requested conversion of Channels AN25 and AN24 is completed
0 = IRQ is not generated

bit 6 **PEND12:** Pending Conversion Status 12 bit

1 = Conversion of Channels AN25 and AN24 is pending; set when selected trigger is asserted
0 = Conversion is complete

bit 5 **SWTRG12:** Software Trigger 12 bit

1 = Starts conversion of AN25 (INTREF) and AN24 (EXTREF) if selected by TRGSRC bits⁽¹⁾
This bit is automatically cleared by hardware when the PEND12 bit is set.
0 = Conversion has not started

Note 1: The trigger source must be set as a global software trigger prior to setting this bit to '1'. If other conversions are in progress, the conversion is performed when the conversion resources are available.

2: This register is not available on dsPIC33FJ32GS406 and dsPIC33FJ64GS406 devices.

REGISTER 22-12: ADCPC6: ADC CONVERT PAIR CONTROL REGISTER 6⁽²⁾ (CONTINUED)

bit 4-0

TRGSRC12<4:0>: Trigger 12 Source Selection bits

Selects trigger source for conversion of analog channels AN25 and AN24.

11111 = Timer2 period match
11110 = PWM Generator 8 current-limit ADC trigger
11101 = PWM Generator 7 current-limit ADC trigger
11100 = PWM Generator 6 current-limit ADC trigger
11011 = PWM Generator 5 current-limit ADC trigger
11010 = PWM Generator 4 current-limit ADC trigger
11001 = PWM Generator 3 current-limit ADC trigger
11000 = PWM Generator 2 current-limit ADC trigger
10111 = PWM Generator 1 current-limit ADC trigger
10110 = PWM Generator 9 secondary trigger selected
10101 = PWM Generator 8 secondary trigger selected
10100 = PWM Generator 7 secondary trigger selected
10011 = PWM Generator 6 secondary trigger selected
10010 = PWM Generator 5 secondary trigger selected
10001 = PWM Generator 4 secondary trigger selected
10000 = PWM Generator 3 secondary trigger selected
01111 = PWM Generator 2 secondary trigger selected
01110 = PWM Generator 1 secondary trigger selected
01101 = PWM secondary special event trigger selected
01100 = Timer1 period match
01011 = PWM Generator 8 primary trigger selected
01010 = PWM Generator 7 primary trigger selected
01001 = PWM Generator 6 primary trigger selected
01000 = PWM Generator 5 primary trigger selected
00111 = PWM Generator 4 primary trigger selected
00110 = PWM Generator 3 primary trigger selected
00101 = PWM Generator 2 primary trigger selected
00100 = PWM Generator 1 primary trigger selected
00011 = PWM special event trigger selected
00010 = Global software trigger selected
00001 = Individual software trigger selected
00000 = No conversion is enabled

- Note 1:** The trigger source must be set as a global software trigger prior to setting this bit to '1'. If other conversions are in progress, the conversion is performed when the conversion resources are available.
- 2:** This register is not available on dsPIC33FJ32GS406 and dsPIC33FJ64GS406 devices.

NOTES:

23.0 HIGH-SPEED ANALOG COMPARATOR

Note 1: This data sheet summarizes the features of the dsPIC33FJ32GS406/606/608/610 and dsPIC33FJ64GS406/606/608/610 families of devices. It is not intended to be a comprehensive reference source. To complement the information in this data sheet, refer to **Section 45. “High-Speed Analog Comparator”** (DS70296) in the “dsPIC33F/PIC24H Family Reference Manual”, which is available from the Microchip web site (www.microchip.com).

2: Some registers and associated bits described in this section may not be available on all devices. Refer to **Section 4.0 “Memory Organization”** in this data sheet for device-specific register and bit information.

The dsPIC33F Switch Mode Power Supply (SMPS) comparator module monitors current and/or voltage transients that may be too fast for the CPU and ADC to capture.

23.1 Features Overview

The SMPS comparator module offers the following major features:

- 16 Selectable Comparator Inputs
- Up to Four Analog Comparators
- 10-Bit DAC for each Analog Comparator

- Programmable Output Polarity
- Interrupt Generation Capability
- DACOUT Pin to provide DAC Output
- DAC has Three Ranges of Operation:
 - $AV_{DD}/2$
 - Internal Reference (INTREF)
 - External Reference (EXTREF)
- ADC Sample-and-Convert Trigger Capability
- Disable Capability reduces Power Consumption
- Functional Support for PWM module:
 - PWM duty cycle control
 - PWM period control
 - PWM Fault detect

23.2 Module Description

Figure 23-1 shows a functional block diagram of one analog comparator from the SMPS comparator module. The analog comparator provides high-speed operation with a typical delay of 20 ns. The comparator has a typical offset voltage of ± 5 mV. The negative input of the comparator is always connected to the DAC circuit. The positive input of the comparator is connected to an analog multiplexer that selects the desired source pin.

The analog comparator input pins are typically shared with pins used by the Analog-to-Digital Converter (ADC) module. Both the comparator and the ADC can use the same pins at the same time. This capability enables a user to measure an input voltage with the ADC and detect voltage transients with the comparator.

FIGURE 23-1: HIGH-SPEED ANALOG COMPARATOR x MODULE BLOCK DIAGRAM



23.3 Module Applications

This module provides a means for the SMPS dsPIC® DSC devices to monitor voltage and currents in a power conversion application. The ability to detect transient conditions and stimulate the dsPIC DSC processor and/or peripherals, without requiring the processor and ADC to constantly monitor voltages or currents, frees the dsPIC DSC to perform other tasks.

The comparator module has a high-speed comparator and an associated 10-bit DAC that provides a programmable reference voltage to the inverting input of the comparator. The polarity of the comparator output is user-programmable. The output of the module can be used in the following modes:

- Generate an Interrupt
- Trigger an ADC Sample-and-Convert Process
- Truncate the PWM Signal (current limit)
- Truncate the PWM Period (current minimum)
- Disable the PWM Outputs (Fault latch)

The output of the comparator module may be used in multiple modes at the same time, such as: 1) generate an interrupt, 2) have the ADC take a sample and convert it, and 3) truncate the PWM output in response to a voltage being detected beyond its expected value.

The comparator module can also be used to wake-up the system from Sleep or Idle mode when the analog input voltage exceeds the programmed threshold voltage.

23.4 DAC

The range of the DAC is controlled via an analog multiplexer that selects either $AV_{DD}/2$, an internal reference source, INTREF, or an external reference source, EXTREF. The full range of the DAC ($AV_{DD}/2$) will typically be used when the chosen input source pin is shared with the ADC. The reduced range option (INTREF) will likely be used when monitoring current levels using a current sense resistor. Usually, the measured voltages in such applications are small ($<1.25V$); therefore the option of using a reduced reference range for the comparator extends the available DAC resolution in these applications. The use of an external reference enables the user to connect to a reference that better suits their application.

DACOUT, shown in [Figure 23-1](#), can only be associated with a single comparator at a given time.

Note: It should be ensured in software that multiple DACOE bits are not set. The output on the DACOUT pin will be indeterminate if multiple comparators enable the DAC output.

23.5 Interaction with I/O Buffers

If the comparator module is enabled and a pin has been selected as the source for the comparator, then the chosen I/O pad must disable the digital input buffer associated with the pad to prevent excessive currents in the digital buffer due to analog input voltages.

23.6 Digital Logic

The CMPCONx register (see [Register 23-1](#)) provides the control logic that configures the comparator module. The digital logic provides a glitch filter for the comparator output to mask transient signals in less than two instruction cycles. In Sleep or Idle mode, the glitch filter is bypassed to enable an asynchronous path from the comparator to the interrupt controller. This asynchronous path can be used to wake-up the processor from Sleep or Idle mode.

The comparator can be disabled while in Idle mode if the CMPSIDL bit is set. If a device has multiple comparators, if any CMPSIDL bit is set, then the entire group of comparators will be disabled while in Idle mode. This behavior reduces complexity in the design of the clock control logic for this module.

The digital logic also provides a one T_{CY} width pulse generator for triggering the ADC and generating interrupt requests.

The CMPDACx (see [Register 23-2](#)) register provides the digital input value to the reference DAC.

If the module is disabled, the DAC and comparator are disabled to reduce power consumption.

23.7 Comparator Input Range

The comparator has a limitation for the input Common-Mode Range (CMR) of $(AV_{DD} - 1.5V)$, typical. This means that both inputs should not exceed this range. As long as one of the inputs is within the Common-Mode Range, the comparator output will be correct. However, any input exceeding the CMR limitation will cause the comparator input to be saturated.

If both inputs exceed the CMR, the comparator output will be indeterminate.

23.8 DAC Output Range

The DAC has a limitation for the maximum reference voltage input of $(AV_{DD} - 1.6)$ volts. An external reference voltage input should not exceed this value or the reference DAC output will become indeterminate.

23.9 Comparator Registers

The comparator module is controlled by the following registers:

- [CMPCONx: Comparator Control x Register](#)
- [CMPDACx: Comparator DAC Control x Register](#)

dsPIC33FJ32GS406/606/608/610 and dsPIC33FJ64GS406/606/608/610

REGISTER 23-1: CMPCONx: COMPARATOR CONTROL x REGISTER

| | | | | | | | |
|--------|-----|---------|-----|-----|-----|-----|-------|
| R/W-0 | U-0 | R/W-0 | U-0 | U-0 | U-0 | U-0 | R/W-0 |
| CMPON | — | CMPSIDL | r | r | r | r | DACOE |
| bit 15 | | | | | | | bit 8 |

| | | | | | | | |
|------------|-------|--------|-----|---------|-----|--------|-------|
| R/W-0 | R/W-0 | R/W-0 | U-0 | R/W-0 | U-0 | R/W-0 | R/W-0 |
| INSEL<1:0> | | EXTREF | r | CMPSTAT | r | CMPPOL | RANGE |
| bit 7 | | | | | | | bit 0 |

| | |
|-------------------|------------------------------------|
| Legend: | r = Reserved bit |
| R = Readable bit | W = Writable bit |
| -n = Value at POR | '1' = Bit is set |
| | U = Unimplemented bit, read as '0' |
| | '0' = Bit is cleared |
| | x = Bit is unknown |

- bit 15 **CMPON:** Comparator Operating Mode bit
 1 = Comparator module is enabled
 0 = Comparator module is disabled (reduces power consumption)
- bit 14 **Unimplemented:** Read as '0'
- bit 13 **CMPSIDL:** Comparator Stop in Idle Mode bit
 1 = Discontinues module operation when device enters Idle mode.
 0 = Continues module operation in Idle mode
 If a device has multiple comparators, any CMPSIDL bit set to '1' disables **ALL** comparators while in Idle mode.
- bit 12-9 **Reserved:** Read as '0'
- bit 8 **DACOE:** DAC Output Enable
 1 = DAC analog voltage is output to DACOUT pin⁽¹⁾
 0 = DAC analog voltage is not connected to DACOUT pin
- bit 7-6 **INSEL<1:0>:** Input Source Select for Comparator bits
 11 = Selects CMPxD input pin
 10 = Selects CMPxC input pin
 01 = Selects CMPxB input pin
 00 = Selects CMPxA input pin
- bit 5 **EXTREF:** Enable External Reference bit
 1 = External source provides reference to DAC (maximum DAC voltage determined by external voltage source)
 0 = Internal reference sources provide reference to DAC (maximum DAC voltage determined by RANGE bit setting)
- bit 4 **Reserved:** Read as '0'
- bit 3 **CMPSTAT:** Current State of Comparator Output Including CMPPOL Selection bit
- bit 2 **Reserved:** Read as '0'
- bit 1 **CMPPOL:** Comparator Output Polarity Control bit
 1 = Output is inverted
 0 = Output is non-inverted
- bit 0 **RANGE:** Selects DAC Output Voltage Range bit
 1 = High Range: Max DAC Value = AVDD/2, 1.65V at 3.3V AVDD
 0 = Low Range: Max DAC Value = INTREF

Note 1: DACOUT can be associated only with a single comparator at any given time. The software must ensure that multiple comparators do not enable the DAC output by setting their respective DACOE bit.

dsPIC33FJ32GS406/606/608/610 and dsPIC33FJ64GS406/606/608/610

REGISTER 23-2: CMPDACx: COMPARATOR DAC CONTROL x REGISTER

| | | | | | | | |
|--------|-----|-----|-----|-----|-----|------------|-------|
| U-0 | U-0 | U-0 | U-0 | U-0 | U-0 | R/W-0 | R/W-0 |
| — | — | — | — | — | — | CMREF<9:8> | |
| bit 15 | | | | | | bit 8 | |

| | | | | | | | |
|------------|-------|-------|-------|-------|-------|-------|-------|
| R/W-0 | R/W-0 | R/W-0 | R/W-0 | R/W-0 | R/W-0 | R/W-0 | R/W-0 |
| CMREF<7:0> | | | | | | | |
| bit 7 | | | | | | bit 0 | |

Legend:

R = Readable bit

W = Writable bit

U = Unimplemented bit, read as '0'

-n = Value at POR

'1' = Bit is set

'0' = Bit is cleared

x = Bit is unknown

bit 15-10 **Reserved:** Read as '0'

bit 9-0 **CMREF<9:0>:** Comparator Reference Voltage Select bits

1111111111 = (CMREF * INTREF/1024) or (CMREF * (AVDD/2)/1024) volts depending on the RANGE bit or (CMREF * EXTREF/1024) if EXTREF is set

-
-
-

0000000000 = 0.0 volts

24.0 SPECIAL FEATURES

Note 1: This data sheet summarizes the features of the dsPIC33FJ32GS406/606/608/610 and dsPIC33FJ64GS406/606/608/610 devices. It is not intended to be a comprehensive reference source. To complement the information in this data sheet, refer to the “dsPIC33F/PIC24H Family Reference Manual”. Please see the Microchip web site (www.microchip.com) for the latest “dsPIC33F/PIC24H Family Reference Manual” sections.

2: Some registers and associated bits described in this section may not be available on all devices. Refer to **Section 4.0 “Memory Organization”** in this data sheet for device-specific register and bit information.

The dsPIC33FJ32GS406/606/608/610 and dsPIC33FJ64GS406/606/608/610 devices include several features intended to maximize application flexibility and reliability, and minimize cost through elimination of external components. These are:

- Flexible Configuration
- Watchdog Timer (WDT)
- Code Protection and CodeGuard™ Security
- JTAG Boundary Scan Interface
- In-Circuit Serial Programming™ (ICSP™)
- In-Circuit Emulation
- Brown-out Reset (BOR)

24.1 Configuration Bits

The dsPIC33FJ32GS406/606/608/610 and dsPIC33FJ64GS406/606/608/610 devices provide non-volatile memory implementations for device Configuration bits. Refer to **Section 25. “Device Configuration”** (DS70194) in the “dsPIC33F/PIC24H Family Reference Manual” for more information on this implementation.

The Configuration bits can be programmed (read as ‘0’), or left unprogrammed (read as ‘1’), to select various device configurations. These bits are mapped starting at program memory location 0xF80000.

The individual Configuration bit descriptions for the Configuration registers are shown in **Table 24-2**.

Note that address, 0xF80000, is beyond the user program memory space. It belongs to the configuration memory space (0x800000-0xFFFFF), which can only be accessed using Table Reads and Table Writes.

To prevent inadvertent configuration changes during code execution, all programmable Configuration bits are write-once. After a bit is initially programmed during a power cycle, it cannot be written again. Changing a device configuration requires that power to the device be cycled.

The device Configuration register map is shown in **Table 24-1**.

TABLE 24-1: DEVICE CONFIGURATION REGISTER MAP

| Address | Name | Bit 7 | Bit 6 | Bit 5 | Bit 4 | Bit 3 | Bit 2 | Bit 1 | Bit 0 |
|----------|----------|-------------------------|-------------------------|------------------------|---------------------------|--------------|------------------------|---------------------------|-------|
| 0xF80000 | FBS | — | — | — | — | BSS<2:0> | | | BWRP |
| 0xF80002 | RESERVED | — | — | — | — | — | — | — | — |
| 0xF80004 | FGS | — | — | — | — | GSS<1:0> | | | GWRP |
| 0xF80006 | FOSCSEL | IESO | — | — | — | | FNOSC<2:0> | | |
| 0xF80008 | FOSC | FCKSM<1:0> | | — | — | — | OSCIOFNC | POSCMD<1:0> | |
| 0xF8000A | FWDT | FWDTEN | WINDIS | — | WDTPRE | WDTPOST<3:0> | | | |
| 0xF8000C | FPOR | — | ALTQIO | ALTSS1 | — | — | FPWRT<2:0> | | |
| 0xF8000E | FICD | Reserved ⁽¹⁾ | Reserved ⁽¹⁾ | JTAGEN | — | — | — | ICS<1:0> | |
| 0xF80010 | FCMP | — | — | CMPPOL1 ⁽²⁾ | HYST1<1:0> ⁽²⁾ | | CMPPOL0 ⁽²⁾ | HYST0<1:0> ⁽²⁾ | |

Legend: — = unimplemented bit, read as ‘0’.

Note 1: These bits are reserved for use by development tools and must be programmed as ‘1’.

2: These bits are reserved on dsPIC33FJXXXGS406 devices and always read as ‘1’.

dsPIC33FJ32GS406/606/608/610 and dsPIC33FJ64GS406/606/608/610

TABLE 24-2: dsPIC33F CONFIGURATION BITS DESCRIPTION

| Bit Field | Register | RTSP Effect | Description |
|-------------|----------|--|--|
| BWRP | FBS | Immediate | Boot Segment Program Flash Write Protection bit 1 = Boot segment can be written 0 = Boot segment is write-protected |
| BSS<2:0> | FBS | Immediate | Boot Segment Program Flash Code Protection Size bits x11 = No boot program Flash segment Boot space is 256 instruction words (except interrupt vectors) 110 = Standard security; boot program Flash segment ends at 0x0003FE 010 = High security; boot program Flash segment ends at 0x0003FE Boot space is 768 instruction words (except interrupt vectors) 101 = Standard security; boot program Flash segment ends at 0x0007FE 001 = High security; boot program Flash segment ends at 0x0007FE Boot space is 1792 instruction words (except interrupt vectors) 100 = Standard security; boot program Flash segment ends at 0x000FFE 000 = High security; boot program Flash segment ends at 0x000FFE |
| GSS<1:0> | FGS | Immediate | General Segment Code-Protect bits 11 = User program memory is not code-protected 10 = Standard security 0x = High security |
| GWRP | FGS | Immediate | General Segment Write-Protect bit 1 = User program memory is not write-protected 0 = User program memory is write-protected |
| IESO | FOSCSEL | Immediate | Two-Speed Oscillator Start-up Enable bit 1 = Start-up device with FRC, then automatically switch to the user selected oscillator source when ready 0 = Start-up device with user selected oscillator source |
| FNOSC<2:0> | FOSCSEL | If clock switch is enabled, RTSP effect is on any device Reset; otherwise, immediate | Initial Oscillator Source Selection bits 111 = Internal Fast RC (FRC) Oscillator with Postscaler 110 = Internal Fast RC (FRC) Oscillator with Divide-by-16 101 = LPRC Oscillator 100 = Secondary (LP) Oscillator 011 = Primary (XT, HS, EC) Oscillator with PLL 010 = Primary (XT, HS, EC) Oscillator 001 = Internal Fast RC (FRC) Oscillator with PLL 000 = FRC Oscillator |
| FCKSM<1:0> | FOSC | Immediate | Clock Switching Mode bits 1x = Clock switching is disabled, Fail-Safe Clock Monitor is disabled 01 = Clock switching is enabled, Fail-Safe Clock Monitor is disabled 00 = Clock switching is enabled, Fail-Safe Clock Monitor is enabled |
| OSCI0FNC | FOSC | Immediate | OSC2 Pin Function bit (except in XT and HS modes) 1 = OSC2 is the clock output 0 = OSC2 is the general purpose digital I/O pin |
| POSCMD<1:0> | FOSC | Immediate | Primary Oscillator Mode Select bits 11 = Primary Oscillator is disabled 10 = HS Crystal Oscillator mode 01 = XT Crystal Oscillator mode 00 = EC (External Clock) mode |

dsPIC33FJ32GS406/606/608/610 and dsPIC33FJ64GS406/606/608/610

TABLE 24-2: dsPIC33F CONFIGURATION BITS DESCRIPTION (CONTINUED)

| Bit Field | Register | RTSP Effect | Description |
|--------------|----------|-------------|--|
| FWDTEN | FWDT | Immediate | Watchdog Timer Enable bit 1 = Watchdog Timer is always enabled (LPRC oscillator cannot be disabled; clearing the SWDTEN bit in the RCON register will have no effect) 0 = Watchdog Timer is enabled/disabled by user software (LPRC can be disabled by clearing the SWDTEN bit in the RCON register) |
| WINDIS | FWDT | Immediate | Watchdog Timer Window Enable bit 1 = Watchdog Timer in Non-Window mode 0 = Watchdog Timer in Window mode |
| WDTPRE | FWDT | Immediate | Watchdog Timer Prescaler bit 1 = 1:128 0 = 1:32 |
| WDTPOST<3:0> | FWDT | Immediate | Watchdog Timer Postscaler bits 1111 = 1:32,768 1110 = 1:16,384 • • • 0001 = 1:2 0000 = 1:1 |
| FPWRT<2:0> | FPOR | Immediate | Power-on Reset Timer Value Select bits 111 = PWRT = 128 ms 110 = PWRT = 64 ms 101 = PWRT = 32 ms 100 = PWRT = 16 ms 011 = PWRT = 8 ms 010 = PWRT = 4 ms 001 = PWRT = 2 ms 000 = PWRT = Disabled |
| JTAGEN | FICD | Immediate | JTAG Enable bit 1 = JTAG is enabled 0 = JTAG is disabled |
| ICS<1:0> | FICD | Immediate | ICD Communication Channel Select Enable bits 11 = Communicate on PGEC1 and PGED1 10 = Communicate on PGEC2 and PGED2 01 = Communicate on PGEC3 and PGED3 00 = Reserved, do not use |
| ALTQIO | FPOR | Immediate | Enable Alternate QE1 Pin bit 1 = QEA1, QEB1 and INDX1 are selected as inputs to QE1 0 = AQEA1, AQEB1 and AINDX1 are selected as inputs to QE1 |
| ALTSS1 | FPOR | Immediate | Enable Alternate SS1 pin bit 1 = $\overline{ASS1}$ is selected as the I/O pin for SPI1 0 = SS1 is selected as the I/O pin for SPI1 |
| CMPPOL0 | FCMP | Immediate | Comparator Hysteresis Polarity bit (for even numbered comparators) 1 = Hysteresis is applied to falling edge 0 = Hysteresis is applied to rising edge |
| HYST0<1:0> | FCMP | Immediate | Comparator Hysteresis Select bits 11 = 45 mV hysteresis 10 = 30 mV hysteresis 01 = 15 mV hysteresis 00 = No hysteresis |

dsPIC33FJ32GS406/606/608/610 and dsPIC33FJ64GS406/606/608/610

TABLE 24-2: dsPIC33F CONFIGURATION BITS DESCRIPTION (CONTINUED)

| Bit Field | Register | RTSP Effect | Description |
|------------|----------|-------------|--|
| CMPPOL1 | FCMP | Immediate | Comparator Hysteresis Polarity bit (for odd numbered comparators) 1 = Hysteresis is applied to falling edge 0 = Hysteresis is applied to rising edge |
| HYST1<1:0> | FCMP | Immediate | Comparator Hysteresis Select bits 11 = 45 mV hysteresis 10 = 30 mV hysteresis 01 = 15 mV hysteresis 00 = No hysteresis |

24.2 On-Chip Voltage Regulator

The dsPIC33FJ32GS406/606/608/610 and dsPIC33FJ64GS406/606/608/610 devices power their core digital logic at a nominal 2.5V. This can create a conflict for designs that are required to operate at a higher typical voltage, such as 3.3V. To simplify system design, all devices in the dsPIC33FJ32GS406/606/608/610 and dsPIC33FJ64GS406/606/608/610 families incorporate an on-chip regulator that allows the device to run its core logic from VDD.

The regulator provides power to the core from the other VDD pins. When the regulator is enabled, a low-ESR (less than 5 ohms) capacitor (such as tantalum or ceramic) must be connected to the VCAP pin (Figure 24-1). This helps to maintain the stability of the regulator. The recommended value for the filter capacitor is provided in Table 27-13, located in Section 27.1 “DC Characteristics”.

Note: It is important for the low-ESR capacitor to be placed as close as possible to the VCAP pin.

On a POR, it takes approximately 20 μ s for the on-chip voltage regulator to generate an output voltage. During this time, designated as TSTARTUP, code execution is disabled. TSTARTUP is applied every time the device resumes operation after any power-down.

FIGURE 24-1: CONNECTIONS FOR THE ON-CHIP VOLTAGE REGULATOR^(1,2,3)



24.3 Brown-out Reset (BOR)

The Brown-out Reset (BOR) module is based on an internal voltage reference circuit. The main purpose of the BOR module is to generate a device Reset when a brown-out condition occurs. Brown-out conditions are generally caused by glitches on the AC mains (for example, missing portions of the AC cycle waveform due to bad power transmission lines, or voltage sags due to excessive current draw when a large inductive load is turned on).

A BOR generates a Reset pulse, which resets the device. The BOR selects the clock source based on the device Configuration bit values (FNOSC<2:0> and POSCMD<1:0>).

If an oscillator mode is selected, the BOR activates the Oscillator Start-up Timer (OST). The system clock is held until OST expires. If the PLL is used, the clock is held until the LOCK bit (OSCCON<5>) is '1'.

Concurrently, the Power-up Timer (PWRT) Time-out (TPWRT) is applied before the internal Reset is released. If TPWRT = 0 and a crystal oscillator is being used, then a nominal delay of TFSCM = 100 is applied. The total delay in this case is TFSCM.

The BOR status bit (RCON<1>) is set to indicate that a BOR has occurred. The BOR circuit continues to operate while in Sleep or Idle modes and resets the device should VDD fall below the BOR threshold voltage.

24.4 Watchdog Timer (WDT)

For dsPIC33FJ32GS406/606/608/610 and dsPIC33FJ64GS406/606/608/610 devices, the WDT is driven by the LPRC oscillator. When the WDT is enabled, the clock source is also enabled.

24.4.1 PRESCALER/POSTSCALER

The nominal WDT clock source from LPRC is 32.767 kHz. This feeds a prescaler that can be configured for either 5-bit (divide-by-32) or 7-bit (divide-by-128) operation. The prescaler is set by the WDTPRE Configuration bit. With a 32.767 kHz input, the prescaler yields a nominal WDT Time-out (TWDT) period of 1 ms in 5-bit mode or 4 ms in 7-bit mode.

A variable postscaler divides down the WDT prescaler output and allows for a wide range of time-out periods. The postscaler is controlled by the WDTPOST<3:0> Configuration bits (FWDT<3:0>), which allow the selection of 16 settings, from 1:1 to 1:32,768. Using the prescaler and postscaler, time-out periods, ranging from 1 ms to 131 seconds, can be achieved.

The WDT, prescaler and postscaler are reset:

- On any device Reset
- On the completion of a clock switch, whether invoked by software (i.e., setting the OSWEN bit after changing the NOSC bits) or by hardware (i.e., Fail-Safe Clock Monitor)
- When a PWRSAV instruction is executed (i.e., Sleep or Idle mode is entered)
- When the device exits Sleep or Idle mode to resume normal operation
- By a CLRWDT instruction during normal execution

Note: The CLRWDT and PWRSAV instructions clear the prescaler and postscaler counts when executed.

24.4.2 SLEEP AND IDLE MODES

If the WDT is enabled, it will continue to run during Sleep or Idle modes. When the WDT time-out occurs, the WDT will wake the device and code execution will continue from where the PWRSAV instruction was executed. The corresponding SLEEP or IDLE bits (RCON<3:2>) will need to be cleared in software after the device wakes up.

24.4.3 ENABLING WDT

The WDT is enabled or disabled by the FWDTEN Configuration bit in the FWDT Configuration register. When the FWDTEN Configuration bit is set, the WDT is always enabled.

The WDT can be optionally controlled in software when the FWDTEN Configuration bit has been programmed to '0'. The WDT is enabled in software by setting the SWDTEN control bit (RCON<5>). The SWDTEN control bit is cleared on any device Reset. The software WDT option allows the user application to enable the WDT for critical code segments and disable the WDT during non-critical segments for maximum power savings.

Note: If the WINDIS bit (FWDT<6>) is cleared, the CLRWDT instruction should be executed by the application software only during the last 1/4 of the WDT period. This CLRWDT window can be determined by using a timer. If a CLRWDT instruction is executed before this window, a WDT Reset occurs.

The WDT flag bit, WDTO (RCON<4>), is not automatically cleared following a WDT time-out. To detect subsequent WDT events, the flag must be cleared in software.

FIGURE 24-2: WDT BLOCK DIAGRAM



24.5 JTAG Interface

dsPIC33FJ32GS406/606/608/610 and dsPIC33FJ64GS406/606/608/610 devices implement a JTAG interface, which supports boundary scan device testing, as well as in-circuit programming. Detailed information on this interface will be provided in future revisions of the document.

24.6 In-Circuit Serial Programming

dsPIC33FJ32GS406/606/608/610 and dsPIC33FJ64GS406/606/608/610 family Digital Signal Controllers (DSCs) can be serially programmed while in the end application circuit. This is done with two lines for clock and data and three other lines for power, ground and the programming sequence. Serial programming allows customers to manufacture boards with unprogrammed devices and then program the Digital Signal Controller just before shipping the product. Serial programming also allows the most recent firmware or a custom firmware to be programmed. Refer to the “*dsPIC33F/PIC24H Flash Programming Specification*” (DS70152) for details about In-Circuit Serial Programming™ (ICSP™).

Any of the three pairs of programming clock/data pins can be used:

- PGEC1 and PGED1
- PGEC2 and PGED2
- PGEC3 and PGED3

24.7 In-Circuit Debugger

When MPLAB ICD 3 is selected as a debugger, the in-circuit debugging functionality is enabled. This function allows simple debugging functions when used with MPLAB® IDE. Debugging functionality is controlled through the EMUCx (Emulation/Debug Clock) and EMUDx (Emulation/Debug Data) pin functions.

Any of the three pairs of debugging clock/data pins can be used:

- PGEC1 and PGED1
- PGEC2 and PGED2
- PGEC3 and PGED3

To use the in-circuit debugger function of the device, the design must implement ICSP connections to \overline{MCLR} , V_{DD} , V_{SS} , PGECx, PGEDx and the EMUDx/EMUCx pin pair. In addition, when the feature is enabled, some of the resources are not available for general use. These resources include the first 80 bytes of data RAM and two I/O pins.

dsPIC33FJ32GS406/606/608/610 and dsPIC33FJ64GS406/606/608/610

24.8 Code Protection and CodeGuard™ Security

The dsPIC33FJ32GS406/606/608/610 and dsPIC33FJ64GS406/606/608/610 devices offer the intermediate implementation of CodeGuard™ Security. CodeGuard Security enables multiple parties to securely share resources (memory, interrupts and peripherals) on a single chip. This feature helps protect individual Intellectual Property in collaborative system designs.

When coupled with software encryption libraries, CodeGuard Security can be used to securely update Flash even when multiple IPs reside on a single chip.

The code protection features are controlled by the Configuration registers: FBS and FGS.

Secure segment and RAM protection is not implemented in dsPIC33FJ32GS406/606/608/610 and dsPIC33FJ64GS406/606/608/610 devices.

Note: Refer to **Section 23. “CodeGuard™ Security”** (DS70199) in the “dsPIC33F/PIC24H Family Reference Manual” for further information on usage, configuration and operation of CodeGuard Security.

TABLE 24-3: CODE FLASH SECURITY SEGMENT SIZES FOR 64-KBYTE DEVICES

| BSS<2:0> = x11, 0K | | BSS<2:0> = x10, 1K | | BSS<2:0> = x01, 4K | | BSS<2:0> = x00, 8K | |
|--------------------|-------------------------------|--------------------|-------------------------------|--------------------|-------------------------------|--------------------|-------------------------------|
| VS = 256 IW | 000000h 0001FEh 000200h | VS = 256 IW | 000000h 0001FEh 000200h | VS = 256 IW | 000000h 0001FEh 000200h | VS = 256 IW | 000000h 0001FEh 000200h |
| | | BS = 768 IW | 000200h 0007FEh 000800h | BS = 3840 IW | | BS = 7936 IW | |
| GS = 21760 IW | | GS = 20992 IW | | GS = 17920 IW | 001FFEh 002000h | GS = 13824 IW | 003FFEh 004000h |
| | 00ABFEh | | 00ABFEh | | 00ABFEh | | 00ABFEh |

TABLE 24-4: CODE FLASH SECURITY SEGMENT SIZES FOR 32-KBYTE DEVICES

| BSS<2:0> = x11, 0K | | BSS<2:0> = x10, 1K | | BSS<2:0> = x01, 4K | | BSS<2:0> = x00, 8K | |
|--------------------|-------------------------------|--------------------|-------------------------------|--------------------|-------------------------------|--------------------|-------------------------------|
| VS = 256 IW | 000000h 0001FEh 000200h | VS = 256 IW | 000000h 0001FEh 000200h | VS = 256 IW | 000000h 0001FEh 000200h | VS = 256 IW | 000000h 0001FEh 000200h |
| | | BS = 768 IW | 000200h 0007FEh 000800h | BS = 3840 IW | | BS = 7936 IW | |
| GS = 11008 IW | 0057FEh | GS = 10240 IW | | GS = 7168 IW | 001FFEh 002000h | GS = 3072 IW | 003FFEh 004000h 0057FEh |
| | 00ABFEh | | 00ABFEh | | 00ABFEh | | 00ABFEh |

25.0 INSTRUCTION SET SUMMARY

Note: This data sheet summarizes the features of the dsPIC33FJ32GS406/606/608/610 and dsPIC33FJ64GS406/606/608/610 devices. It is not intended to be a comprehensive reference source. To complement the information in this data sheet, refer to the “dsPIC33F/PIC24H Family Reference Manual”. Please see the Microchip web site (www.microchip.com) for the latest “dsPIC33F/PIC24H Family Reference Manual” sections.

The dsPIC33F instruction set is identical to that of the dsPIC30F.

Most instructions are a single program memory word (24 bits). Only three instructions require two program memory locations.

Each single-word instruction is a 24-bit word, divided into an 8-bit opcode, which specifies the instruction type and one or more operands, which further specify the operation of the instruction.

The instruction set is highly orthogonal and is grouped into five basic categories:

- Word or byte-oriented operations
- Bit-oriented operations
- Literal operations
- DSP operations
- Control operations

Table 25-1 shows the general symbols used in describing the instructions.

The dsPIC33F instruction set summary in Table 25-2 lists all the instructions, along with the status flags affected by each instruction.

Most word or byte-oriented W register instructions (including barrel shift instructions) have three operands:

- The first source operand, which is typically a register ‘Wb’ without any address modifier
- The second source operand, which is typically a register ‘Ws’ with or without an address modifier
- The destination of the result, which is typically a register ‘Wd’ with or without an address modifier

However, word or byte-oriented file register instructions have two operands:

- The file register specified by the value, ‘f’
- The destination, which could be either the file register, ‘f’, or the W0 register, which is denoted as ‘WREG’

Most bit-oriented instructions (including simple rotate/shift instructions) have two operands:

- The W register (with or without an address modifier) or file register (specified by the value of ‘Ws’ or ‘f’)
- The bit in the W register or file register (specified by a literal value or indirectly by the contents of register ‘Wb’)

The literal instructions that involve data movement can use some of the following operands:

- A literal value to be loaded into a W register or file register (specified by ‘k’)
- The W register or file register where the literal value is to be loaded (specified by ‘Wb’ or ‘f’)

However, literal instructions that involve arithmetic or logical operations use some of the following operands:

- The first source operand, which is a register ‘Wb’ without any address modifier
- The second source operand, which is a literal value
- The destination of the result (only if not the same as the first source operand), which is typically a register ‘Wd’ with or without an address modifier

The MAC class of DSP instructions can use some of the following operands:

- The accumulator (A or B) to be used (required operand)
- The W registers to be used as the two operands
- The X and Y address space prefetch operations
- The X and Y address space prefetch destinations
- The accumulator write-back destination

The other DSP instructions do not involve any multiplication and can include:

- The accumulator to be used (required)
- The source or destination operand (designated as Wso or Wdo, respectively) with or without an address modifier
- The amount of shift specified by a W register, ‘Wn’, or a literal value

The control instructions can use some of the following operands:

- A program memory address
- The mode of the Table Read and Table Write instructions

dsPIC33FJ32GS406/606/608/610 and dsPIC33FJ64GS406/606/608/610

Most instructions are a single word. Certain double-word instructions are designed to provide all the required information in these 48 bits. In the second word, the 8 MSBs are '0's. If this second word is executed as an instruction (by itself), it will execute as a NOP.

The double-word instructions execute in two instruction cycles.

Most single-word instructions are executed in a single instruction cycle, unless a conditional test is true, or the Program Counter is changed as a result of the instruction. In these cases, the execution takes two instruction cycles with the additional instruction cycle(s) executed as a NOP. Notable exceptions are the BRA

(unconditional/computed branch), indirect CALL/GOTO, all Table Reads and Writes, and RETURN/RETFIE instructions, which are single-word instructions but take two or three cycles. Certain instructions that involve skipping over the subsequent instruction require either two or three cycles if the skip is performed, depending on whether the instruction being skipped is a single-word or two-word instruction. Moreover, double-word moves require two cycles.

Note: For more details on the instruction set, refer to the "16-bit MCU and DSC Programmer's Reference Manual" (DS70157).

TABLE 25-1: SYMBOLS USED IN OPCODE DESCRIPTIONS

| Field | Description |
|-----------------|---|
| #text | Means "literal defined by text" |
| (text) | Means "content of text" |
| [text] | Means "the location addressed by text" |
| { } | Optional field or operation |
| <n:m> | Register bit field |
| .b | Byte mode selection |
| .d | Double-Word mode selection |
| .S | Shadow register select |
| .w | Word mode selection (default) |
| Acc | One of two accumulators {A, B} |
| AWB | Accumulator Write-Back Destination Address register $\in \{W13, [W13]+ = 2\}$ |
| bit4 | 4-bit bit selection field (used in word-addressed instructions) $\in \{0...15\}$ |
| C, DC, N, OV, Z | MCU Status bits: Carry, Digit Carry, Negative, Overflow, Sticky Zero |
| Expr | Absolute address, label or expression (resolved by the linker) |
| f | File register address $\in \{0x0000...0x1FFF\}$ |
| lit1 | 1-bit unsigned literal $\in \{0,1\}$ |
| lit4 | 4-bit unsigned literal $\in \{0...15\}$ |
| lit5 | 5-bit unsigned literal $\in \{0...31\}$ |
| lit8 | 8-bit unsigned literal $\in \{0...255\}$ |
| lit10 | 10-bit unsigned literal $\in \{0...255\}$ for Byte mode, $\{0:1023\}$ for Word mode |
| lit14 | 14-bit unsigned literal $\in \{0...16384\}$ |
| lit16 | 16-bit unsigned literal $\in \{0...65535\}$ |
| lit23 | 23-bit unsigned literal $\in \{0...8388608\}$; LSb must be '0' |
| None | Field does not require an entry, can be blank |
| OA, OB, SA, SB | DSP Status bits: ACCA Overflow, ACCB Overflow, ACCA Saturate, ACCB Saturate |
| PC | Program Counter |
| Slit10 | 10-bit signed literal $\in \{-512...511\}$ |
| Slit16 | 16-bit signed literal $\in \{-32768...32767\}$ |
| Slit6 | 6-bit signed literal $\in \{-16...16\}$ |
| Wb | Base W register $\in \{W0..W15\}$ |
| Wd | Destination W register $\in \{Wd, [Wd], [Wd++] , [Wd--], [++Wd], [--Wd] \}$ |
| Wdo | Destination W register $\in \{Wnd, [Wnd], [Wnd++] , [Wnd--], [++Wnd], [--Wnd], [Wnd+Wb] \}$ |
| Wm,Wn | Dividend, Divisor Working register pair (Direct Addressing) |

TABLE 25-1: SYMBOLS USED IN OPCODE DESCRIPTIONS (CONTINUED)

| Field | Description |
|-------|---|
| Wm*Wm | Multiplicand and Multiplier Working register pair for Square instructions \in {W4 * W4, W5 * W5, W6 * W6, W7 * W7} |
| Wm*Wn | Multiplicand and Multiplier Working register pair for DSP instructions \in {W4 * W5, W4 * W6, W4 * W7, W5 * W6, W5 * W7, W6 * W7} |
| Wn | One of 16 Working registers \in {W0..W15} |
| Wnd | One of 16 Destination Working registers \in {W0...W15} |
| Wns | One of 16 Source Working registers \in {W0...W15} |
| WREG | W0 (Working register used in file register instructions) |
| Ws | Source W register \in { Ws, [Ws], [Ws++], [Ws--], [++Ws], [--Ws] } |
| Wso | Source W register \in { Wns, [Wns], [Wns++], [Wns--], [++Wns], [--Wns], [Wns+Wb] } |
| Wx | X Data Space Prefetch Address register for DSP instructions \in {[W8] + = 6, [W8] + = 4, [W8] + = 2, [W8], [W8] - = 6, [W8] - = 4, [W8] - = 2, [W9] + = 6, [W9] + = 4, [W9] + = 2, [W9], [W9] - = 6, [W9] - = 4, [W9] - = 2, [W9 + W12], none} |
| Wxd | X Data Space Prefetch Destination register for DSP instructions \in {W4...W7} |
| Wy | Y Data Space Prefetch Address register for DSP instructions \in {[W10] + = 6, [W10] + = 4, [W10] + = 2, [W10], [W10] - = 6, [W10] - = 4, [W10] - = 2, [W11] + = 6, [W11] + = 4, [W11] + = 2, [W11], [W11] - = 6, [W11] - = 4, [W11] - = 2, [W11 + W12], none} |
| Wyd | Y Data Space Prefetch Destination register for DSP instructions \in {W4...W7} |

TABLE 25-2: INSTRUCTION SET OVERVIEW

| Base Instr # | Assembly Mnemonic | Assembly Syntax | Description | # of Words | # of Cycles | Status Flags Affected |
|--------------------|-------------------|-----------------------------|--|------------|-------------|-----------------------|
| 1 | ADD | ADD <i>Acc</i> | Add Accumulators | 1 | 1 | OA,OB,SA,SB |
| | | ADD <i>f</i> | $f = f + WREG$ | 1 | 1 | C,DC,N,OV,Z |
| | | ADD <i>f, WREG</i> | $WREG = f + WREG$ | 1 | 1 | C,DC,N,OV,Z |
| | | ADD <i>#lit10, Wn</i> | $Wd = lit10 + Wd$ | 1 | 1 | C,DC,N,OV,Z |
| | | ADD <i>Wb, Ws, Wd</i> | $Wd = Wb + Ws$ | 1 | 1 | C,DC,N,OV,Z |
| | | ADD <i>Wb, #lit5, Wd</i> | $Wd = Wb + lit5$ | 1 | 1 | C,DC,N,OV,Z |
| | | ADD <i>Wso, #Slit4, Acc</i> | 16-Bit Signed Add to Accumulator | 1 | 1 | OA,OB,SA,SB |
| 2 | ADDC | ADDC <i>f</i> | $f = f + WREG + (C)$ | 1 | 1 | C,DC,N,OV,Z |
| | | ADDC <i>f, WREG</i> | $WREG = f + WREG + (C)$ | 1 | 1 | C,DC,N,OV,Z |
| | | ADDC <i>#lit10, Wn</i> | $Wd = lit10 + Wd + (C)$ | 1 | 1 | C,DC,N,OV,Z |
| | | ADDC <i>Wb, Ws, Wd</i> | $Wd = Wb + Ws + (C)$ | 1 | 1 | C,DC,N,OV,Z |
| | | ADDC <i>Wb, #lit5, Wd</i> | $Wd = Wb + lit5 + (C)$ | 1 | 1 | C,DC,N,OV,Z |
| 3 | AND | AND <i>f</i> | $f = f .AND. WREG$ | 1 | 1 | N,Z |
| | | AND <i>f, WREG</i> | $WREG = f .AND. WREG$ | 1 | 1 | N,Z |
| | | AND <i>#lit10, Wn</i> | $Wd = lit10 .AND. Wd$ | 1 | 1 | N,Z |
| | | AND <i>Wb, Ws, Wd</i> | $Wd = Wb .AND. Ws$ | 1 | 1 | N,Z |
| | | AND <i>Wb, #lit5, Wd</i> | $Wd = Wb .AND. lit5$ | 1 | 1 | N,Z |
| 4 | ASR | ASR <i>f</i> | $f = \text{Arithmetic Right Shift } f$ | 1 | 1 | C,N,OV,Z |
| | | ASR <i>f, WREG</i> | $WREG = \text{Arithmetic Right Shift } f$ | 1 | 1 | C,N,OV,Z |
| | | ASR <i>Ws, Wd</i> | $Wd = \text{Arithmetic Right Shift } Ws$ | 1 | 1 | C,N,OV,Z |
| | | ASR <i>Wb, Wns, Wnd</i> | $Wnd = \text{Arithmetic Right Shift } Wb \text{ by } Wns$ | 1 | 1 | N,Z |
| | | ASR <i>Wb, #lit5, Wnd</i> | $Wnd = \text{Arithmetic Right Shift } Wb \text{ by } lit5$ | 1 | 1 | N,Z |
| 5 | BCLR | BCLR <i>f, #bit4</i> | Bit Clear <i>f</i> | 1 | 1 | None |
| | | BCLR <i>Ws, #bit4</i> | Bit Clear <i>Ws</i> | 1 | 1 | None |
| 6 | BRA | BRA <i>C, Expr</i> | Branch if Carry | 1 | 1 (2) | None |
| | | BRA <i>GE, Expr</i> | Branch if Greater Than or Equal | 1 | 1 (2) | None |
| | | BRA <i>GEU, Expr</i> | Branch if Unsigned Greater Than or Equal | 1 | 1 (2) | None |
| | | BRA <i>GT, Expr</i> | Branch if Greater Than | 1 | 1 (2) | None |
| | | BRA <i>GTU, Expr</i> | Branch if Unsigned Greater Than | 1 | 1 (2) | None |
| | | BRA <i>LE, Expr</i> | Branch if Less Than or Equal | 1 | 1 (2) | None |
| | | BRA <i>LEU, Expr</i> | Branch if Unsigned Less Than or Equal | 1 | 1 (2) | None |
| | | BRA <i>LT, Expr</i> | Branch if Less Than | 1 | 1 (2) | None |
| | | BRA <i>LTU, Expr</i> | Branch if Unsigned Less Than | 1 | 1 (2) | None |
| | | BRA <i>N, Expr</i> | Branch if Negative | 1 | 1 (2) | None |
| | | BRA <i>NC, Expr</i> | Branch if Not Carry | 1 | 1 (2) | None |
| | | BRA <i>NN, Expr</i> | Branch if Not Negative | 1 | 1 (2) | None |
| | | BRA <i>NOV, Expr</i> | Branch if Not Overflow | 1 | 1 (2) | None |
| | | BRA <i>NZ, Expr</i> | Branch if Not Zero | 1 | 1 (2) | None |
| | | BRA <i>OA, Expr</i> | Branch if Accumulator A Overflow | 1 | 1 (2) | None |
| | | BRA <i>OB, Expr</i> | Branch if Accumulator B Overflow | 1 | 1 (2) | None |
| | | BRA <i>OV, Expr</i> | Branch if Overflow | 1 | 1 (2) | None |
| | | BRA <i>SA, Expr</i> | Branch if Accumulator A Saturated | 1 | 1 (2) | None |
| | | BRA <i>SB, Expr</i> | Branch if Accumulator B Saturated | 1 | 1 (2) | None |
| | | BRA <i>Expr</i> | Branch Unconditionally | 1 | 2 | None |
| BRA <i>Z, Expr</i> | Branch if Zero | 1 | 1 (2) | None | | |
| BRA <i>Wn</i> | Computed Branch | 1 | 2 | None | | |
| 7 | BSET | BSET <i>f, #bit4</i> | Bit Set <i>f</i> | 1 | 1 | None |
| | | BSET <i>Ws, #bit4</i> | Bit Set <i>Ws</i> | 1 | 1 | None |
| 8 | BSW | BSW.C <i>Ws, Wb</i> | Write C bit to $Ws < Wb >$ | 1 | 1 | None |
| | | BSW.Z <i>Ws, Wb</i> | Write Z bit to $Ws < Wb >$ | 1 | 1 | None |

TABLE 25-2: INSTRUCTION SET OVERVIEW (CONTINUED)

| Base Instr # | Assembly Mnemonic | Assembly Syntax | Description | # of Words | # of Cycles | Status Flags Affected |
|--------------|-------------------|--------------------------------|---|------------|---------------|-----------------------|
| 9 | BTG | BTG f, #bit4 | Bit Toggle f | 1 | 1 | None |
| | | BTG Ws, #bit4 | Bit Toggle Ws | 1 | 1 | None |
| 10 | BTSC | BTSC f, #bit4 | Bit Test f, Skip if Clear | 1 | 1 (2 or 3) | None |
| | | BTSC Ws, #bit4 | Bit Test Ws, Skip if Clear | 1 | 1 (2 or 3) | None |
| 11 | BTSS | BTSS f, #bit4 | Bit Test f, Skip if Set | 1 | 1 (2 or 3) | None |
| | | BTSS Ws, #bit4 | Bit Test Ws, Skip if Set | 1 | 1 (2 or 3) | None |
| 12 | BTST | BTST f, #bit4 | Bit Test f | 1 | 1 | Z |
| | | BTST.C Ws, #bit4 | Bit Test Ws to C | 1 | 1 | C |
| | | BTST.Z Ws, #bit4 | Bit Test Ws to Z | 1 | 1 | Z |
| | | BTST.C Ws, Wb | Bit Test Ws<Wb> to C | 1 | 1 | C |
| | | BTST.Z Ws, Wb | Bit Test Ws<Wb> to Z | 1 | 1 | Z |
| 13 | BTSTS | BTSTS f, #bit4 | Bit Test then Set f | 1 | 1 | Z |
| | | BTSTS.C Ws, #bit4 | Bit Test Ws to C, then Set | 1 | 1 | C |
| | | BTSTS.Z Ws, #bit4 | Bit Test Ws to Z, then Set | 1 | 1 | Z |
| 14 | CALL | CALL lit23 | Call Subroutine | 2 | 2 | None |
| | | CALL Wn | Call Indirect Subroutine | 1 | 2 | None |
| 15 | CLR | CLR f | f = 0x0000 | 1 | 1 | None |
| | | CLR WREG | WREG = 0x0000 | 1 | 1 | None |
| | | CLR Ws | Ws = 0x0000 | 1 | 1 | None |
| | | CLR Acc, Wx, Wxd, Wy, Wyd, AWB | Clear Accumulator | 1 | 1 | OA,OB,SA,SB |
| 16 | CLRWDT | CLRWDT | Clear Watchdog Timer | 1 | 1 | WDTO,Sleep |
| 17 | COM | COM f | f = \bar{f} | 1 | 1 | N,Z |
| | | COM f, WREG | WREG = \bar{f} | 1 | 1 | N,Z |
| | | COM Ws, Wd | Wd = \overline{Ws} | 1 | 1 | N,Z |
| 18 | CP | CP f | Compare f with WREG | 1 | 1 | C,DC,N,OV,Z |
| | | CP Wb, #lit5 | Compare Wb with lit5 | 1 | 1 | C,DC,N,OV,Z |
| | | CP Wb, Ws | Compare Wb with Ws (Wb – Ws) | 1 | 1 | C,DC,N,OV,Z |
| 19 | CP0 | CP0 f | Compare f with 0x0000 | 1 | 1 | C,DC,N,OV,Z |
| | | CP0 Ws | Compare Ws with 0x0000 | 1 | 1 | C,DC,N,OV,Z |
| 20 | CPB | CPB f | Compare f with WREG, with Borrow | 1 | 1 | C,DC,N,OV,Z |
| | | CPB Wb, #lit5 | Compare Wb with lit5, with Borrow | 1 | 1 | C,DC,N,OV,Z |
| | | CPB Wb, Ws | Compare Wb with Ws, with Borrow (Wb – Ws – C) | 1 | 1 | C,DC,N,OV,Z |
| 21 | CPSEQ | CPSEQ Wb, Wn | Compare Wb with Wn, Skip if = | 1 | 1 (2 or 3) | None |
| 22 | CPSGT | CPSGT Wb, Wn | Compare Wb with Wn, Skip if > | 1 | 1 (2 or 3) | None |
| 23 | CPSLT | CPSLT Wb, Wn | Compare Wb with Wn, Skip if < | 1 | 1 (2 or 3) | None |
| 24 | CPSNE | CPSNE Wb, Wn | Compare Wb with Wn, Skip if ≠ | 1 | 1 (2 or 3) | None |
| 25 | DAW | DAW Wn | Wn = Decimal Adjust Wn | 1 | 1 | C |
| 26 | DEC | DEC f | f = f – 1 | 1 | 1 | C,DC,N,OV,Z |
| | | DEC f, WREG | WREG = f – 1 | 1 | 1 | C,DC,N,OV,Z |
| | | DEC Ws, Wd | Wd = Ws – 1 | 1 | 1 | C,DC,N,OV,Z |
| 27 | DEC2 | DEC2 f | f = f – 2 | 1 | 1 | C,DC,N,OV,Z |
| | | DEC2 f, WREG | WREG = f – 2 | 1 | 1 | C,DC,N,OV,Z |
| | | DEC2 Ws, Wd | Wd = Ws – 2 | 1 | 1 | C,DC,N,OV,Z |
| 28 | DISI | DISI #lit14 | Disable Interrupts for k Instruction Cycles | 1 | 1 | None |

dsPIC33FJ32GS406/606/608/610 and dsPIC33FJ64GS406/606/608/610

TABLE 25-2: INSTRUCTION SET OVERVIEW (CONTINUED)

| Base Instr # | Assembly Mnemonic | Assembly Syntax | Description | # of Words | # of Cycles | Status Flags Affected |
|---------------|--|---------------------------------------|--|------------|-------------|-----------------------|
| 29 | DIV | DIV.S Wm, Wn | Signed 16/16-Bit Integer Divide | 1 | 18 | N,Z,C,OV |
| | | DIV.SD Wm, Wn | Signed 32/16-Bit Integer Divide | 1 | 18 | N,Z,C,OV |
| | | DIV.U Wm, Wn | Unsigned 16/16-Bit Integer Divide | 1 | 18 | N,Z,C,OV |
| | | DIV.UD Wm, Wn | Unsigned 32/16-Bit Integer Divide | 1 | 18 | N,Z,C,OV |
| 30 | DIVF | DIVF Wm, Wn | Signed 16/16-Bit Fractional Divide | 1 | 18 | N,Z,C,OV |
| 31 | DO | DO #lit14, Expr | Do code to PC + Expr, lit14 + 1 times | 2 | 2 | None |
| | | DO Wn, Expr | Do code to PC + Expr, (Wn) + 1 times | 2 | 2 | None |
| 32 | ED | ED Wm*Wm, Acc, Wx, Wy, Wxd | Euclidean Distance (no accumulate) | 1 | 1 | OA,OB,OAB,SA,SB,SAB |
| 33 | EDAC | EDAC Wm*Wm, Acc, Wx, Wy, Wxd | Euclidean Distance | 1 | 1 | OA,OB,OAB,SA,SB,SAB |
| 34 | EXCH | EXCH Wns, Wnd | Swap Wns with Wnd | 1 | 1 | None |
| 35 | FBCL | FBCL Ws, Wnd | Find Bit Change from Left (MSb) Side | 1 | 1 | C |
| 36 | FF1L | FF1L Ws, Wnd | Find First One from Left (MSb) Side | 1 | 1 | C |
| 37 | FF1R | FF1R Ws, Wnd | Find First One from Right (LSb) Side | 1 | 1 | C |
| 38 | GOTO | GOTO Expr | Go to Address | 2 | 2 | None |
| | | GOTO Wn | Go to Indirect | 1 | 2 | None |
| 39 | INC | INC f | f = f + 1 | 1 | 1 | C,DC,N,OV,Z |
| | | INC f, WREG | WREG = f + 1 | 1 | 1 | C,DC,N,OV,Z |
| | | INC Ws, Wd | Wd = Ws + 1 | 1 | 1 | C,DC,N,OV,Z |
| 40 | INC2 | INC2 f | f = f + 2 | 1 | 1 | C,DC,N,OV,Z |
| | | INC2 f, WREG | WREG = f + 2 | 1 | 1 | C,DC,N,OV,Z |
| | | INC2 Ws, Wd | Wd = Ws + 2 | 1 | 1 | C,DC,N,OV,Z |
| 41 | IOR | IOR f | f = f .IOR. WREG | 1 | 1 | N,Z |
| | | IOR f, WREG | WREG = f .IOR. WREG | 1 | 1 | N,Z |
| | | IOR #lit10, Wn | Wd = lit10 .IOR. Wd | 1 | 1 | N,Z |
| | | IOR Wb, Ws, Wd | Wd = Wb .IOR. Ws | 1 | 1 | N,Z |
| | | IOR Wb, #lit5, Wd | Wd = Wb .IOR. lit5 | 1 | 1 | N,Z |
| 42 | LAC | LAC Wso, #Slit4, Acc | Load Accumulator | 1 | 1 | OA,OB,OAB,SA,SB,SAB |
| 43 | LNK | LNK #lit14 | Link Frame Pointer | 1 | 1 | None |
| 44 | LSR | LSR f | f = Logical Right Shift f | 1 | 1 | C,N,OV,Z |
| | | LSR f, WREG | WREG = Logical Right Shift f | 1 | 1 | C,N,OV,Z |
| | | LSR Ws, Wd | Wd = Logical Right Shift Ws | 1 | 1 | C,N,OV,Z |
| | | LSR Wb, Wns, Wnd | Wnd = Logical Right Shift Wb by Wns | 1 | 1 | N,Z |
| | | LSR Wb, #lit5, Wnd | Wnd = Logical Right Shift Wb by lit5 | 1 | 1 | N,Z |
| 45 | MAC | MAC Wm*Wn, Acc, Wx, Wxd, Wy, Wyd, AWB | Multiply and Accumulate | 1 | 1 | OA,OB,OAB,SA,SB,SAB |
| | | MAC Wm*Wm, Acc, Wx, Wxd, Wy, Wyd | Square and Accumulate | 1 | 1 | OA,OB,OAB,SA,SB,SAB |
| 46 | MOV | MOV f, Wn | Move f to Wn | 1 | 1 | None |
| | | MOV f | Move f to f | 1 | 1 | N,Z |
| | | MOV f, WREG | Move f to WREG | 1 | 1 | None |
| | | MOV #lit16, Wn | Move 16-Bit Literal to Wn | 1 | 1 | None |
| | | MOV.b #lit8, Wn | Move 8-Bit Literal to Wn | 1 | 1 | None |
| | | MOV Wn, f | Move Wn to f | 1 | 1 | None |
| | | MOV Wso, Wdo | Move Ws to Wd | 1 | 1 | None |
| | | MOV WREG, f | Move WREG to f | 1 | 1 | None |
| | | MOV.D Wns, Wd | Move Double from W(ns):W(ns + 1) to Wd | 1 | 2 | None |
| MOV.D Ws, Wnd | Move Double from Ws to W(nd + 1):W(nd) | 1 | 2 | None | | |
| 47 | MOVSAC | MOVSAC Acc, Wx, Wxd, Wy, Wyd, AWB | Prefetch and Store Accumulator | 1 | 1 | None |

TABLE 25-2: INSTRUCTION SET OVERVIEW (CONTINUED)

| Base Instr # | Assembly Mnemonic | Assembly Syntax | Description | # of Words | # of Cycles | Status Flags Affected |
|--------------|-------------------|--|--|------------|-------------|-----------------------|
| 48 | MPY | MPY Wm*Wn, Acc, Wx, Wxd, Wy, Wyd | Multiply Wm by Wn to Accumulator | 1 | 1 | OA,OB,OAB, SA,SB,SAB |
| | | MPY Wm*Wm, Acc, Wx, Wxd, Wy, Wyd | Square Wm to Accumulator | 1 | 1 | OA,OB,OAB, SA,SB,SAB |
| 49 | MPY.N | MPY.N Wm*Wn, Acc, Wx, Wxd, Wy, Wyd | -(Multiply Wm by Wn) to Accumulator | 1 | 1 | None |
| 50 | MSC | MSC Wm*Wm, Acc, Wx, Wxd, Wy, Wyd / AWB | Multiply and Subtract from Accumulator | 1 | 1 | OA,OB,OAB, SA,SB,SAB |
| 51 | MUL | MUL.SS Wb, Ws, Wnd | {Wnd + 1, Wnd} = signed(Wb) * signed(Ws) | 1 | 1 | None |
| | | MUL.SU Wb, Ws, Wnd | {Wnd + 1, Wnd} = signed(Wb) * unsigned(Ws) | 1 | 1 | None |
| | | MUL.US Wb, Ws, Wnd | {Wnd + 1, Wnd} = unsigned(Wb) * signed(Ws) | 1 | 1 | None |
| | | MUL.UU Wb, Ws, Wnd | {Wnd + 1, Wnd} = unsigned(Wb) * unsigned(Ws) | 1 | 1 | None |
| | | MUL.SU Wb, #lit5, Wnd | {Wnd + 1, Wnd} = signed(Wb) * unsigned(lit5) | 1 | 1 | None |
| | | MUL.UU Wb, #lit5, Wnd | {Wnd + 1, Wnd} = unsigned(Wb) * unsigned(lit5) | 1 | 1 | None |
| | | MUL f | W3:W2 = f * WREG | 1 | 1 | None |
| 52 | NEG | NEG Acc | Negate Accumulator | 1 | 1 | OA,OB,OAB, SA,SB,SAB |
| | | NEG f | $f = \bar{f} + 1$ | 1 | 1 | C,DC,N,OV,Z |
| | | NEG f, WREG | WREG = $\bar{f} + 1$ | 1 | 1 | C,DC,N,OV,Z |
| | | NEG Ws, Wd | $Wd = \overline{Ws} + 1$ | 1 | 1 | C,DC,N,OV,Z |
| 53 | NOP | NOP | No Operation | 1 | 1 | None |
| | | NOPR | No Operation | 1 | 1 | None |
| 54 | POP | POP f | Pop f from Top-of-Stack (TOS) | 1 | 1 | None |
| | | POP Wdo | Pop from Top-of-Stack (TOS) to Wdo | 1 | 1 | None |
| | | POP.D Wnd | Pop from Top-of-Stack (TOS) to W(nd):W(nd + 1) | 1 | 2 | None |
| | | POP.S | Pop Shadow Registers | 1 | 1 | All |
| 55 | PUSH | PUSH f | Push f to Top-of-Stack (TOS) | 1 | 1 | None |
| | | PUSH Wso | Push Wso to Top-of-Stack (TOS) | 1 | 1 | None |
| | | PUSH.D Wns | Push W(ns):W(ns + 1) to Top-of-Stack (TOS) | 1 | 2 | None |
| | | PUSH.S | Push Shadow Registers | 1 | 1 | None |
| 56 | PWRSVAV | PWRSVAV #lit1 | Go into Sleep or Idle mode | 1 | 1 | WDTO,Sleep |
| 57 | RCALL | RCALL Expr | Relative Call | 1 | 2 | None |
| | | RCALL Wn | Computed Call | 1 | 2 | None |
| 58 | REPEAT | REPEAT #lit14 | Repeat Next Instruction lit14 + 1 times | 1 | 1 | None |
| | | REPEAT Wn | Repeat Next Instruction (Wn) + 1 times | 1 | 1 | None |
| 59 | RESET | RESET | Software Device Reset | 1 | 1 | None |
| 60 | RETFIE | RETFIE | Return from interrupt | 1 | 3 (2) | None |
| 61 | RETLW | RETLW #lit10, Wn | Return with Literal in Wn | 1 | 3 (2) | None |
| 62 | RETURN | RETURN | Return from Subroutine | 1 | 3 (2) | None |
| 63 | RLC | RLC f | f = Rotate Left through Carry f | 1 | 1 | C,N,Z |
| | | RLC f, WREG | WREG = Rotate Left through Carry f | 1 | 1 | C,N,Z |
| | | RLC Ws, Wd | Wd = Rotate Left through Carry Ws | 1 | 1 | C,N,Z |
| 64 | RLNC | RLNC f | f = Rotate Left (No Carry) f | 1 | 1 | N,Z |
| | | RLNC f, WREG | WREG = Rotate Left (No Carry) f | 1 | 1 | N,Z |
| | | RLNC Ws, Wd | Wd = Rotate Left (No Carry) Ws | 1 | 1 | N,Z |
| 65 | RRC | RRC f | f = Rotate Right through Carry f | 1 | 1 | C,N,Z |
| | | RRC f, WREG | WREG = Rotate Right through Carry f | 1 | 1 | C,N,Z |
| | | RRC Ws, Wd | Wd = Rotate Right through Carry Ws | 1 | 1 | C,N,Z |

dsPIC33FJ32GS406/606/608/610 and dsPIC33FJ64GS406/606/608/610

TABLE 25-2: INSTRUCTION SET OVERVIEW (CONTINUED)

| Base Instr # | Assembly Mnemonic | Assembly Syntax | Description | # of Words | # of Cycles | Status Flags Affected |
|-------------------|-------------------|------------------------|---------------------------------------|-------------|-------------|-----------------------|
| 66 | RRNC | RRNC f | f = Rotate Right (No Carry) f | 1 | 1 | N,Z |
| | | RRNC f, WREG | WREG = Rotate Right (No Carry) f | 1 | 1 | N,Z |
| | | RRNC Ws, Wd | Wd = Rotate Right (No Carry) Ws | 1 | 1 | N,Z |
| 67 | SAC | SAC Acc, #Slit4, Wdo | Store Accumulator | 1 | 1 | None |
| | | SAC.R Acc, #Slit4, Wdo | Store Rounded Accumulator | 1 | 1 | None |
| 68 | SE | SE Ws, Wnd | Wnd = Sign-Extended Ws | 1 | 1 | C,N,Z |
| 69 | SETM | SETM f | f = 0xFFFF | 1 | 1 | None |
| | | SETM WREG | WREG = 0xFFFF | 1 | 1 | None |
| | | SETM Ws | Ws = 0xFFFF | 1 | 1 | None |
| 70 | SFTAC | SFTAC Acc, Wn | Arithmetic Shift Accumulator by (Wn) | 1 | 1 | OA,OB,OAB,SA,SB,SAB |
| | | SFTAC Acc, #Slit6 | Arithmetic Shift Accumulator by Slit6 | 1 | 1 | OA,OB,OAB,SA,SB,SAB |
| 71 | SL | SL f | f = Left Shift f | 1 | 1 | C,N,OV,Z |
| | | SL f, WREG | WREG = Left Shift f | 1 | 1 | C,N,OV,Z |
| | | SL Ws, Wd | Wd = Left Shift Ws | 1 | 1 | C,N,OV,Z |
| | | SL Wb, Wns, Wnd | Wnd = Left Shift Wb by Wns | 1 | 1 | N,Z |
| | | SL Wb, #lit5, Wnd | Wnd = Left Shift Wb by lit5 | 1 | 1 | N,Z |
| 72 | SUB | SUB Acc | Subtract Accumulators | 1 | 1 | OA,OB,OAB,SA,SB,SAB |
| | | SUB f | f = f - WREG | 1 | 1 | C,DC,N,OV,Z |
| | | SUB f, WREG | WREG = f - WREG | 1 | 1 | C,DC,N,OV,Z |
| | | SUB #lit10, Wn | Wn = Wn - lit10 | 1 | 1 | C,DC,N,OV,Z |
| | | SUB Wb, Ws, Wd | Wd = Wb - Ws | 1 | 1 | C,DC,N,OV,Z |
| SUB Wb, #lit5, Wd | Wd = Wb - lit5 | 1 | 1 | C,DC,N,OV,Z | | |
| 73 | SUBB | SUBB f | f = f - WREG - (\overline{C}) | 1 | 1 | C,DC,N,OV,Z |
| | | SUBB f, WREG | WREG = f - WREG - (\overline{C}) | 1 | 1 | C,DC,N,OV,Z |
| | | SUBB #lit10, Wn | Wn = Wn - lit10 - (\overline{C}) | 1 | 1 | C,DC,N,OV,Z |
| | | SUBB Wb, Ws, Wd | Wd = Wb - Ws - (\overline{C}) | 1 | 1 | C,DC,N,OV,Z |
| | | SUBB Wb, #lit5, Wd | Wd = Wb - lit5 - (\overline{C}) | 1 | 1 | C,DC,N,OV,Z |
| 74 | SUBR | SUBR f | f = WREG - f | 1 | 1 | C,DC,N,OV,Z |
| | | SUBR f, WREG | WREG = WREG - f | 1 | 1 | C,DC,N,OV,Z |
| | | SUBR Wb, Ws, Wd | Wd = Ws - Wb | 1 | 1 | C,DC,N,OV,Z |
| | | SUBR Wb, #lit5, Wd | Wd = lit5 - Wb | 1 | 1 | C,DC,N,OV,Z |
| 75 | SUBBR | SUBBR f | f = WREG - f - (\overline{C}) | 1 | 1 | C,DC,N,OV,Z |
| | | SUBBR f, WREG | WREG = WREG - f - (\overline{C}) | 1 | 1 | C,DC,N,OV,Z |
| | | SUBBR Wb, Ws, Wd | Wd = Ws - Wb - (\overline{C}) | 1 | 1 | C,DC,N,OV,Z |
| | | SUBBR Wb, #lit5, Wd | Wd = lit5 - Wb - (\overline{C}) | 1 | 1 | C,DC,N,OV,Z |
| 76 | SWAP | SWAP.b Wn | Wn = Nibble Swap Wn | 1 | 1 | None |
| | | SWAP Wn | Wn = Byte Swap Wn | 1 | 1 | None |
| 77 | TBLRDH | TBLRDH Ws, Wd | Read Prog<23:16> to Wd<7:0> | 1 | 2 | None |
| 78 | TBLRDL | TBLRDL Ws, Wd | Read Prog<15:0> to Wd | 1 | 2 | None |
| 79 | TBLWTH | TBLWTH Ws, Wd | Write Ws<7:0> to Prog<23:16> | 1 | 2 | None |
| 80 | TBLWTL | TBLWTL Ws, Wd | Write Ws to Prog<15:0> | 1 | 2 | None |
| 81 | ULNK | ULNK | Unlink Frame Pointer | 1 | 1 | None |
| 82 | XOR | XOR f | f = f .XOR. WREG | 1 | 1 | N,Z |
| | | XOR f, WREG | WREG = f .XOR. WREG | 1 | 1 | N,Z |
| | | XOR #lit10, Wn | Wd = lit10 .XOR. Wd | 1 | 1 | N,Z |
| | | XOR Wb, Ws, Wd | Wd = Wb .XOR. Ws | 1 | 1 | N,Z |
| | | XOR Wb, #lit5, Wd | Wd = Wb .XOR. lit5 | 1 | 1 | N,Z |
| 83 | ZE | ZE Ws, Wnd | Wnd = Zero-Extend Ws | 1 | 1 | C,Z,N |

26.0 DEVELOPMENT SUPPORT

The PIC[®] microcontrollers and dsPIC[®] digital signal controllers are supported with a full range of software and hardware development tools:

- Integrated Development Environment
 - MPLAB[®] IDE Software
- Compilers/Assemblers/Linkers
 - MPLAB C Compiler for Various Device Families
 - HI-TECH C[®] for Various Device Families
 - MPASM[™] Assembler
 - MPLINK[™] Object Linker/
MPLIB[™] Object Librarian
 - MPLAB Assembler/Linker/Librarian for Various Device Families
- Simulators
 - MPLAB SIM Software Simulator
- Emulators
 - MPLAB REAL ICE[™] In-Circuit Emulator
- In-Circuit Debuggers
 - MPLAB ICD 3
 - PICKit[™] 3 Debug Express
- Device Programmers
 - PICKit[™] 2 Programmer
 - MPLAB PM3 Device Programmer
- Low-Cost Demonstration/Development Boards, Evaluation Kits, and Starter Kits

26.1 MPLAB Integrated Development Environment Software

The MPLAB IDE software brings an ease of software development previously unseen in the 8/16/32-bit microcontroller market. The MPLAB IDE is a Windows[®] operating system-based application that contains:

- A single graphical interface to all debugging tools
 - Simulator
 - Programmer (sold separately)
 - In-Circuit Emulator (sold separately)
 - In-Circuit Debugger (sold separately)
- A full-featured editor with color-coded context
- A multiple project manager
- Customizable data windows with direct edit of contents
- High-level source code debugging
- Mouse over variable inspection
- Drag and drop variables from source to watch windows
- Extensive on-line help
- Integration of select third party tools, such as IAR C Compilers

The MPLAB IDE allows you to:

- Edit your source files (either C or assembly)
- One-touch compile or assemble, and download to emulator and simulator tools (automatically updates all project information)
- Debug using:
 - Source files (C or assembly)
 - Mixed C and assembly
 - Machine code

MPLAB IDE supports multiple debugging tools in a single development paradigm, from the cost-effective simulators, through low-cost in-circuit debuggers, to full-featured emulators. This eliminates the learning curve when upgrading to tools with increased flexibility and power.

26.2 MPLAB C Compilers for Various Device Families

The MPLAB C Compiler code development systems are complete ANSI C compilers for Microchip's PIC18, PIC24 and PIC32 families of microcontrollers and the dsPIC30 and dsPIC33 families of digital signal controllers. These compilers provide powerful integration capabilities, superior code optimization and ease of use.

For easy source level debugging, the compilers provide symbol information that is optimized to the MPLAB IDE debugger.

26.3 HI-TECH C for Various Device Families

The HI-TECH C Compiler code development systems are complete ANSI C compilers for Microchip's PIC family of microcontrollers and the dsPIC family of digital signal controllers. These compilers provide powerful integration capabilities, omniscient code generation and ease of use.

For easy source level debugging, the compilers provide symbol information that is optimized to the MPLAB IDE debugger.

The compilers include a macro assembler, linker, pre-processor, and one-step driver, and can run on multiple platforms.

26.4 MPASM Assembler

The MPASM Assembler is a full-featured, universal macro assembler for PIC10/12/16/18 MCUs.

The MPASM Assembler generates relocatable object files for the MPLINK Object Linker, Intel® standard HEX files, MAP files to detail memory usage and symbol reference, absolute LST files that contain source lines and generated machine code and COFF files for debugging.

The MPASM Assembler features include:

- Integration into MPLAB IDE projects
- User-defined macros to streamline assembly code
- Conditional assembly for multi-purpose source files
- Directives that allow complete control over the assembly process

26.5 MPLINK Object Linker/ MPLIB Object Librarian

The MPLINK Object Linker combines relocatable objects created by the MPASM Assembler and the MPLAB C18 C Compiler. It can link relocatable objects from precompiled libraries, using directives from a linker script.

The MPLIB Object Librarian manages the creation and modification of library files of precompiled code. When a routine from a library is called from a source file, only the modules that contain that routine will be linked in with the application. This allows large libraries to be used efficiently in many different applications.

The object linker/library features include:

- Efficient linking of single libraries instead of many smaller files
- Enhanced code maintainability by grouping related modules together
- Flexible creation of libraries with easy module listing, replacement, deletion and extraction

26.6 MPLAB Assembler, Linker and Librarian for Various Device Families

MPLAB Assembler produces relocatable machine code from symbolic assembly language for PIC24, PIC32 and dsPIC devices. MPLAB C Compiler uses the assembler to produce its object file. The assembler generates relocatable object files that can then be archived or linked with other relocatable object files and archives to create an executable file. Notable features of the assembler include:

- Support for the entire device instruction set
- Support for fixed-point and floating-point data
- Command line interface
- Rich directive set
- Flexible macro language
- MPLAB IDE compatibility

26.7 MPLAB SIM Software Simulator

The MPLAB SIM Software Simulator allows code development in a PC-hosted environment by simulating the PIC MCUs and dsPIC® DSCs on an instruction level. On any given instruction, the data areas can be examined or modified and stimuli can be applied from a comprehensive stimulus controller. Registers can be logged to files for further run-time analysis. The trace buffer and logic analyzer display extend the power of the simulator to record and track program execution, actions on I/O, most peripherals and internal registers.

The MPLAB SIM Software Simulator fully supports symbolic debugging using the MPLAB C Compilers, and the MPASM and MPLAB Assemblers. The software simulator offers the flexibility to develop and debug code outside of the hardware laboratory environment, making it an excellent, economical software development tool.

26.8 MPLAB REAL ICE In-Circuit Emulator System

MPLAB REAL ICE In-Circuit Emulator System is Microchip's next generation high-speed emulator for Microchip Flash DSC and MCU devices. It debugs and programs PIC® Flash MCUs and dsPIC® Flash DSCs with the easy-to-use, powerful graphical user interface of the MPLAB Integrated Development Environment (IDE), included with each kit.

The emulator is connected to the design engineer's PC using a high-speed USB 2.0 interface and is connected to the target with either a connector compatible with in-circuit debugger systems (RJ11) or with the new high-speed, noise tolerant, Low-Voltage Differential Signal (LVDS) interconnection (CAT5).

The emulator is field upgradable through future firmware downloads in MPLAB IDE. In upcoming releases of MPLAB IDE, new devices will be supported, and new features will be added. MPLAB REAL ICE offers significant advantages over competitive emulators including low-cost, full-speed emulation, run-time variable watches, trace analysis, complex breakpoints, a ruggedized probe interface and long (up to three meters) interconnection cables.

26.9 MPLAB ICD 3 In-Circuit Debugger System

MPLAB ICD 3 In-Circuit Debugger System is Microchip's most cost effective high-speed hardware debugger/programmer for Microchip Flash Digital Signal Controller (DSC) and microcontroller (MCU) devices. It debugs and programs PIC® Flash microcontrollers and dsPIC® DSCs with the powerful, yet easy-to-use graphical user interface of MPLAB Integrated Development Environment (IDE).

The MPLAB ICD 3 In-Circuit Debugger probe is connected to the design engineer's PC using a high-speed USB 2.0 interface and is connected to the target with a connector compatible with the MPLAB ICD 2 or MPLAB REAL ICE systems (RJ-11). MPLAB ICD 3 supports all MPLAB ICD 2 headers.

26.10 PICKit 3 In-Circuit Debugger/ Programmer and PICKit 3 Debug Express

The MPLAB PICKit 3 allows debugging and programming of PIC® and dsPIC® Flash microcontrollers at a most affordable price point using the powerful graphical user interface of the MPLAB Integrated Development Environment (IDE). The MPLAB PICKit 3 is connected to the design engineer's PC using a full speed USB interface and can be connected to the target via an Microchip debug (RJ-11) connector (compatible with MPLAB ICD 3 and MPLAB REAL ICE). The connector uses two device I/O pins and the reset line to implement in-circuit debugging and In-Circuit Serial Programming™.

The PICKit 3 Debug Express include the PICKit 3, demo board and microcontroller, hookup cables and CDROM with user's guide, lessons, tutorial, compiler and MPLAB IDE software.

26.11 PICkit 2 Development Programmer/Debugger and PICkit 2 Debug Express

The PICkit™ 2 Development Programmer/Debugger is a low-cost development tool with an easy to use interface for programming and debugging Microchip's Flash families of microcontrollers. The full featured Windows® programming interface supports baseline (PIC10F, PIC12F5xx, PIC16F5xx), midrange (PIC12F6xx, PIC16F), PIC18F, PIC24, dsPIC30, dsPIC33, and PIC32 families of 8-bit, 16-bit, and 32-bit microcontrollers, and many Microchip Serial EEPROM products. With Microchip's powerful MPLAB Integrated Development Environment (IDE) the PICkit™ 2 enables in-circuit debugging on most PIC® microcontrollers. In-Circuit-Debugging runs, halts and single steps the program while the PIC microcontroller is embedded in the application. When halted at a breakpoint, the file registers can be examined and modified.

The PICkit 2 Debug Express include the PICkit 2, demo board and microcontroller, hookup cables and CDROM with user's guide, lessons, tutorial, compiler and MPLAB IDE software.

26.12 MPLAB PM3 Device Programmer

The MPLAB PM3 Device Programmer is a universal, CE compliant device programmer with programmable voltage verification at VDDMIN and VDDMAX for maximum reliability. It features a large LCD display (128 x 64) for menus and error messages and a modular, detachable socket assembly to support various package types. The ICSP™ cable assembly is included as a standard item. In Stand-Alone mode, the MPLAB PM3 Device Programmer can read, verify and program PIC devices without a PC connection. It can also set code protection in this mode. The MPLAB PM3 connects to the host PC via an RS-232 or USB cable. The MPLAB PM3 has high-speed communications and optimized algorithms for quick programming of large memory devices and incorporates an MMC card for file storage and data applications.

26.13 Demonstration/Development Boards, Evaluation Kits, and Starter Kits

A wide variety of demonstration, development and evaluation boards for various PIC MCUs and dsPIC DSCs allows quick application development on fully functional systems. Most boards include prototyping areas for adding custom circuitry and provide application firmware and source code for examination and modification.

The boards support a variety of features, including LEDs, temperature sensors, switches, speakers, RS-232 interfaces, LCD displays, potentiometers and additional EEPROM memory.

The demonstration and development boards can be used in teaching environments, for prototyping custom circuits and for learning about various microcontroller applications.

In addition to the PICDEM™ and dsPICDEM™ demonstration/development board series of circuits, Microchip has a line of evaluation kits and demonstration software for analog filter design, KEELOQ® security ICs, CAN, IrDA®, PowerSmart battery management, SEEVAL® evaluation system, Sigma-Delta ADC, flow rate sensing, plus many more.

Also available are starter kits that contain everything needed to experience the specified device. This usually includes a single application and debug capability, all on one board.

Check the Microchip web page (www.microchip.com) for the complete list of demonstration, development and evaluation kits.

27.0 ELECTRICAL CHARACTERISTICS

This section provides an overview of dsPIC33FJ32GS406/606/608/610 and dsPIC33FJ64GS406/606/608/610 electrical characteristics. Additional information will be provided in future revisions of this document as it becomes available.

Absolute maximum ratings for the dsPIC33FJ32GS406/606/608/610 and dsPIC33FJ64GS406/606/608/610 family are listed below. Exposure to these maximum rating conditions for extended periods may affect device reliability. Functional operation of the device at these or any other conditions above the parameters indicated in the operation listings of this specification is not implied.

Absolute Maximum Ratings⁽¹⁾

| | |
|---|-----------------------|
| Ambient temperature under bias | -40°C to +125°C |
| Storage temperature | -65°C to +150°C |
| Voltage on VDD with respect to VSS | -0.3V to +4.0V |
| Voltage on any pin that is not 5V tolerant with respect to VSS ⁽³⁾ | -0.3V to (VDD + 0.3V) |
| Voltage on any 5V tolerant pin with respect to VSS when VDD ≥ 3.0V ⁽³⁾ | -0.3V to +5.6V |
| Voltage on any 5V tolerant pin with respect to VSS when VDD < 3.0V ⁽³⁾ | -0.3V to (VDD + 0.3V) |
| Maximum current out of VSS pin | 300 mA |
| Maximum current into VDD pin ⁽²⁾ | 250 mA |
| Maximum current sourced/sunk by any 4x I/O pin | 15 mA |
| Maximum current sourced/sunk by any 8x I/O pin | 25 mA |
| Maximum current sourced/sunk by any 16x I/O pin | 45 mA |
| Maximum current sunk by all ports | 200 mA |
| Maximum current sourced by all ports ⁽²⁾ | 200mA |

Note 1: Stresses above those listed under “Absolute Maximum Ratings” may cause permanent damage to the device. This is a stress rating only, and functional operation of the device at those or any other conditions above those indicated in the operation listings of this specification is not implied. Exposure to maximum rating conditions for extended periods may affect device reliability.

2: Maximum allowable current is a function of the device maximum power dissipation (see [Table 27-2](#)).

3: See the “[Pin Diagrams](#)” section for 5V tolerant pins.

dsPIC33FJ32GS406/606/608/610 and dsPIC33FJ64GS406/606/608/610

27.1 DC Characteristics

TABLE 27-1: OPERATING MIPS vs. VOLTAGE

| Characteristic | VDD Range (in Volts) | Temp Range (in °C) | Max MIPS |
|----------------|-------------------------|-----------------------|--|
| | | | dsPIC33FJ32GS406/606/608/610 and dsPIC33FJ64GS406/606/608/610 |
| — | 3.0-3.6V ⁽¹⁾ | -40°C to +85°C | 40 |
| — | 3.0-3.6V ⁽¹⁾ | -40°C to +125°C | 40 |

Note 1: Overall functional device operation at $V_{BORMIN} < V_{DD} < V_{DDMIN}$ is tested but not characterized. All device analog modules, such as the ADC, etc., will function but with degraded performance below V_{DDMIN} . See Parameter [BO10](#) in [Table 27-11](#) for the BOR values.

TABLE 27-2: THERMAL OPERATING CONDITIONS

| Rating | Symbol | Min | Typ | Max | Unit |
|--|-------------------|-------------------------------------|-----|------|------|
| Industrial Temperature Devices | | | | | |
| Operating Junction Temperature Range | TJ | -40 | — | +125 | °C |
| Operating Ambient Temperature Range | TA | -40 | — | +85 | °C |
| Extended Temperature Devices | | | | | |
| Operating Junction Temperature Range | TJ | -40 | — | +140 | °C |
| Operating Ambient Temperature Range | TA | -40 | — | +125 | °C |
| Power Dissipation: Internal Chip Power Dissipation: $P_{INT} = V_{DD} \times (I_{DD} - \Sigma I_{OH})$ I/O Pin Power Dissipation: $I/O = \Sigma (\{V_{DD} - V_{OH}\} \times I_{OH}) + \Sigma (V_{OL} \times I_{OL})$ | PD | P _{INT} + P _{I/O} | | | W |
| Maximum Allowed Power Dissipation | PD _{MAX} | $(T_J - T_A) / \theta_{JA}$ | | | W |

TABLE 27-3: THERMAL PACKAGING CHARACTERISTICS

| Characteristic | Symbol | Typ | Max | Unit | Notes |
|---|---------------|------|-----|------|-------|
| Package Thermal Resistance, 64-Pin QFN (9x9x0.9 mm) | θ_{JA} | 28 | — | °C/W | 1 |
| Package Thermal Resistance, 64-Pin TQFP (10x10x1 mm) | θ_{JA} | 39 | — | °C/W | 1 |
| Package Thermal Resistance, 80-Pin TQFP (12x12x1 mm) | θ_{JA} | 53.1 | — | °C/W | 1 |
| Package Thermal Resistance, 100-Pin TQFP (12x12x1 mm) | θ_{JA} | 43 | — | °C/W | 1 |
| Package Thermal Resistance, 100-Pin TQFP (14x14x1 mm) | θ_{JA} | 43 | — | °C/W | 1 |

Note 1: Junction to ambient thermal resistance, Theta-JA (θ_{JA}) numbers are achieved by package simulations.

TABLE 27-4: DC TEMPERATURE AND VOLTAGE SPECIFICATIONS

| DC CHARACTERISTICS | | | Standard Operating Conditions: 3.0V to 3.6V (unless otherwise stated) Operating temperature -40°C ≤ TA ≤ +85°C for Industrial -40°C ≤ TA ≤ +125°C for Extended | | | | |
|--------------------------|--------|---|---|--------------------|-----|-------|-------------------------|
| Param No. | Symbol | Characteristic | Min | Typ ⁽¹⁾ | Max | Units | Conditions |
| Operating Voltage | | | | | | | |
| DC10 | VDD | Supply Voltage⁽⁴⁾ | 3.0 | — | 3.6 | V | Industrial and extended |
| DC12 | VDR | RAM Data Retention Voltage⁽²⁾ | 1.8 | — | — | V | |
| DC16 | VPOR | VDD Start Voltage to Ensure Internal Power-on Reset Signal | — | — | VSS | V | |
| DC17 | SVDD | VDD Rise Rate⁽³⁾ to Ensure Internal Power-on Reset Signal | 0.03 | — | — | V/ms | 0-3.0V in 0.1s |

- Note 1:** Data in “Typ” column is at 3.3V, +25°C unless otherwise stated.
- 2:** This is the limit to which VDD may be lowered without losing RAM data.
- 3:** These parameters are characterized but not tested in manufacturing.
- 4:** Overall functional device operation at VBORMIN < VDD < VDDMIN is tested but not characterized. All device analog modules such as the ADC, etc., will function but with degraded performance below VDDMIN. See Parameter BO10 in [Table 27-11](#) for the BOR values.

dsPIC33FJ32GS406/606/608/610 and dsPIC33FJ64GS406/606/608/610

TABLE 27-5: DC CHARACTERISTICS: OPERATING CURRENT (IDD)

| DC CHARACTERISTICS | | Standard Operating Conditions: 3.0V to 3.6V (unless otherwise stated) Operating temperature -40°C ≤ TA ≤ +85°C for Industrial -40°C ≤ TA ≤ +125°C for Extended | | |
|--|------------------------|---|-------|------------|
| Parameter No. | Typical ⁽¹⁾ | Max | Units | Conditions |
| Operating Current (IDD)⁽²⁾ | | | | |
| DC20d | 21 | 30 | mA | -40°C |
| DC20a | 21 | 30 | mA | +25°C |
| DC20b | 21 | 30 | mA | +85°C |
| DC20c | 22 | 30 | mA | +125°C |
| DC21d | 28 | 40 | mA | -40°C |
| DC21a | 28 | 40 | mA | +25°C |
| DC21b | 28 | 40 | mA | +85°C |
| DC21c | 29 | 40 | mA | +125°C |
| DC22d | 35 | 45 | mA | -40°C |
| DC22a | 35 | 45 | mA | +25°C |
| DC22b | 35 | 45 | mA | +85°C |
| DC22c | 36 | 45 | mA | +125°C |
| DC23d | 49 | 60 | mA | -40°C |
| DC23a | 49 | 60 | mA | +25°C |
| DC23b | 49 | 60 | mA | +85°C |
| DC23c | 50 | 60 | mA | +125°C |
| DC24d | 66 | 75 | mA | -40°C |
| DC24a | 66 | 75 | mA | +25°C |
| DC24b | 66 | 75 | mA | +85°C |
| DC24c | 67 | 75 | mA | +125°C |
| DC25d | 153 | 170 | mA | -40°C |
| DC25a | 154 | 170 | mA | +25°C |
| DC25b | 155 | 170 | mA | +85°C |
| DC25c | 156 | 170 | mA | +125°C |

Note 1: Data in "Typical" column is at 3.3V, +25°C unless otherwise stated.

2: IDD is primarily a function of the operating voltage and frequency. Other factors, such as I/O pin loading and switching rate, oscillator type, internal code execution pattern and temperature, also have an impact on the current consumption. The test conditions for all IDD measurements are as follows:

- Oscillator is configured in EC mode with PLL, OSC1 is driven with external square wave from rail-to-rail (EC clock overshoot/undershoot < 250 mV required)
- CLKO is configured as an I/O input pin in the Configuration Word
- All I/O pins are configured as inputs and pulled to Vss
- $\overline{\text{MCLR}} = \text{VDD}$, WDT and FSCM are disabled
- CPU, SRAM, program memory and data memory are operational
- No peripheral modules are operating; however, every peripheral is being clocked (all PMDx bits are all '0's)
- CPU executing `while(1)` statement
- JTAG disabled

3: These parameters are characterized but not tested in manufacturing.

TABLE 27-5: DC CHARACTERISTICS: OPERATING CURRENT (IDD) (CONTINUED)

| DC CHARACTERISTICS | | | Standard Operating Conditions: 3.0V to 3.6V (unless otherwise stated) Operating temperature -40°C ≤ TA ≤ +85°C for Industrial -40°C ≤ TA ≤ +125°C for Extended | |
|--|------------------------|-----|---|------------|
| Parameter No. | Typical ⁽¹⁾ | Max | Units | Conditions |
| Operating Current (IDD)⁽²⁾ | | | | |
| DC26d | 122 | 135 | mA | -40°C |
| DC26a | 123 | 135 | mA | +25°C |
| DC26b | 124 | 135 | mA | +85°C |
| DC26c | 125 | 135 | mA | +125°C |
| DC27d | 107 | 120 | mA | -40°C |
| DC27a | 108 | 120 | mA | +25°C |
| DC27b | 109 | 120 | mA | +85°C |
| DC27c | 110 | 120 | mA | +125°C |
| DC28d | 88 | 100 | mA | -40°C |
| DC28a | 89 | 100 | mA | +25°C |
| DC28b | 89 | 100 | mA | +85°C |
| DC28c | 89 | 100 | mA | +125°C |

Note 1: Data in “Typical” column is at 3.3V, +25°C unless otherwise stated.

- 2:** IDD is primarily a function of the operating voltage and frequency. Other factors, such as I/O pin loading and switching rate, oscillator type, internal code execution pattern and temperature, also have an impact on the current consumption. The test conditions for all IDD measurements are as follows:
- Oscillator is configured in EC mode with PLL, OSC1 is driven with external square wave from rail-to-rail (EC clock overshoot/undershoot < 250 mV required)
 - CLKO is configured as an I/O input pin in the Configuration Word
 - All I/O pins are configured as inputs and pulled to VSS
 - MCLR = VDD, WDT and FSCM are disabled
 - CPU, SRAM, program memory and data memory are operational
 - No peripheral modules are operating; however, every peripheral is being clocked (all PMDx bits are all ‘0’s)
 - CPU executing `while(1)` statement
 - JTAG disabled
- 3:** These parameters are characterized but not tested in manufacturing.

dsPIC33FJ32GS406/606/608/610 and dsPIC33FJ64GS406/606/608/610

TABLE 27-6: DC CHARACTERISTICS: IDLE CURRENT (IDLE)

| DC CHARACTERISTICS | | | Standard Operating Conditions: 3.0V to 3.6V (unless otherwise stated) Operating temperature $-40^{\circ}\text{C} \leq T_A \leq +85^{\circ}\text{C}$ for Industrial $-40^{\circ}\text{C} \leq T_A \leq +125^{\circ}\text{C}$ for Extended | | |
|---|------------------------|-----|---|------------|--------------------------------|
| Parameter No. | Typical ⁽¹⁾ | Max | Units | Conditions | |
| Idle Current (IDLE): Core Off, Clock On Base Current⁽²⁾ | | | | | |
| DC40d | 8 | 15 | mA | -40°C | 3.3V 10 MIPS |
| DC40a | 9 | 15 | mA | +25°C | |
| DC40b | 9 | 15 | mA | +85°C | |
| DC40c | 10 | 15 | mA | +125°C | |
| DC41d | 11 | 20 | mA | -40°C | 3.3V 16 MIPS ⁽³⁾ |
| DC41a | 11 | 20 | mA | +25°C | |
| DC41b | 11 | 20 | mA | +85°C | |
| DC41c | 12 | 20 | mA | +125°C | |
| DC42d | 14 | 25 | mA | -40°C | 3.3V 20 MIPS ⁽³⁾ |
| DC42a | 14 | 25 | mA | +25°C | |
| DC42b | 14 | 25 | mA | +85°C | |
| DC42c | 15 | 25 | mA | +125°C | |
| DC43d | 20 | 30 | mA | -40°C | 3.3V 30 MIPS ⁽³⁾ |
| DC43a | 20 | 30 | mA | +25°C | |
| DC43b | 21 | 30 | mA | +85°C | |
| DC43c | 22 | 30 | mA | +125°C | |
| DC44d | 29 | 40 | mA | -40°C | 3.3V 40 MIPS |
| DC44a | 29 | 40 | mA | +25°C | |
| DC44b | 30 | 40 | mA | +85°C | |
| DC44c | 31 | 40 | mA | +125°C | |

Note 1: Data in “Typical” column is at 3.3V, +25°C unless otherwise stated.

2: Base Idle current (IDLE) is measured as follows:

- CPU core is off, oscillator is configured in EC mode and external clock is active, OSC1 is driven with external square wave from rail-to-rail (EC clock overshoot/undershoot < 250 mV required)
- CLKO is configured as an I/O input pin in the Configuration Word
- All I/O pins are configured as inputs and pulled to V_{SS}
- MCLR = V_{DD}, WDT and FSCM are disabled
- No peripheral modules are operating; however, every peripheral is being clocked (all PMD_x bits are all ‘0’s)
- JTAG is disabled

3: These parameters are characterized but not tested in manufacturing.

TABLE 27-7: DC CHARACTERISTICS: POWER-DOWN CURRENT (IPD)

| DC CHARACTERISTICS | | | Standard Operating Conditions: 3.0V to 3.6V (unless otherwise stated) Operating temperature -40°C ≤ TA ≤ +85°C for Industrial -40°C ≤ TA ≤ +125°C for Extended | | |
|---|------------------------|------|---|------------|--|
| Parameter No. | Typical ⁽¹⁾ | Max | Units | Conditions | |
| Power-Down Current (IPD)^(2,4) | | | | | |
| DC60d | 50 | 200 | μA | -40°C | 3.3V Base Power-Down Current |
| DC60a | 50 | 200 | μA | +25°C | |
| DC60b | 200 | 500 | μA | +85°C | |
| DC60c | 600 | 1000 | μA | +125°C | |
| DC61d | 8 | 13 | μA | -40°C | 3.3V Watchdog Timer Current: ΔI _{WDT} ⁽³⁾ |
| DC61a | 10 | 15 | μA | +25°C | |
| DC61b | 12 | 20 | μA | +85°C | |
| DC61c | 13 | 25 | μA | +125°C | |

Note 1: Data in the Typical column is at 3.3V, +25°C unless otherwise stated.

2: IPD (Sleep) current is measured as follows:

- CPU core is off, oscillator is configured in EC mode and external clock is active, OSC1 is driven with external square wave from rail-to-rail (EC clock overshoot/undershoot < 250 mV required)
- CLKO is configured as an I/O input pin in the Configuration Word
- All I/O pins are configured as inputs and pulled to VSS
- $\overline{\text{MCLR}} = V_{\text{DD}}$, WDT and FSCM are disabled
- All peripheral modules are disabled (all PMDx bits are all '1's)
- The VREGS bit (RCON<8>) = 0 (i.e., core regulator is set to standby while the device is in Sleep mode)
- JTAG disabled

3: The Δ current is the additional current consumed when the WDT module is enabled. This current should be added to the base IPD current.

4: These currents are measured on the device containing the most memory in this family.

dsPIC33FJ32GS406/606/608/610 and dsPIC33FJ64GS406/606/608/610

TABLE 27-8: DC CHARACTERISTICS: DOZE CURRENT (IDOZE)

| DC CHARACTERISTICS | | | Standard Operating Conditions: 3.0V to 3.6V (unless otherwise stated) Operating temperature $-40^{\circ}\text{C} \leq T_A \leq +85^{\circ}\text{C}$ for Industrial $-40^{\circ}\text{C} \leq T_A \leq +125^{\circ}\text{C}$ for Extended | | | | |
|---|------------------------|-----|---|-------|------------|------|---------|
| Parameter No. | Typical ⁽¹⁾ | Max | Doze Ratio | Units | Conditions | | |
| Doze Current (IDOZE)⁽²⁾ | | | | | | | |
| DC73a | 45 | 60 | 1:2 | mA | -40°C | 3.3V | 40 MIPS |
| DC73f | 40 | 60 | 1:64 | mA | | | |
| DC73g | 40 | 60 | 1:128 | mA | | | |
| DC70a | 43 | 60 | 1:2 | mA | +25°C | 3.3V | 40 MIPS |
| DC70f | 38 | 60 | 1:64 | mA | | | |
| DC70g | 38 | 60 | 1:128 | mA | | | |
| DC71a | 42 | 60 | 1:2 | mA | +85°C | 3.3V | 40 MIPS |
| DC71f | 37 | 60 | 1:64 | mA | | | |
| DC71g | 37 | 60 | 1:128 | mA | | | |
| DC72a | 41 | 60 | 1:2 | mA | +125°C | 3.3V | 40 MIPS |
| DC72f | 36 | 60 | 1:64 | mA | | | |
| DC72g | 36 | 60 | 1:128 | mA | | | |

Note 1: Data in the Typical column is at 3.3V, +25°C unless otherwise stated.

2: IDOZE is primarily a function of the operating voltage and frequency. Other factors, such as I/O pin loading and switching rate, oscillator type, internal code execution pattern and temperature, also have an impact on the current consumption. The test conditions for all IDOZE measurements are as follows:

- Oscillator is configured in EC mode and external clock is active, OSC1 is driven with external square wave from rail-to-rail (EC clock overshoot/undershoot < 250 mV required)
- CLKO is configured as an I/O input pin in the Configuration Word
- All I/O pins are configured as inputs and pulled to Vss
- $\overline{\text{MCLR}} = V_{\text{DD}}$, WDT and FSCM are disabled
- CPU, SRAM, program memory and data memory are operational
- No peripheral modules are operating; however, every peripheral is being clocked (all PMDx bits are all '0's)
- CPU executing `while(1)` statement
- JTAG disabled

TABLE 27-9: DC CHARACTERISTICS: I/O PIN INPUT SPECIFICATIONS

| DC CHARACTERISTICS | | | Standard Operating Conditions: 3.0V to 3.6V (unless otherwise stated) Operating temperature -40°C ≤ TA ≤ +85°C for Industrial -40°C ≤ TA ≤ +125°C for Extended | | | | |
|--------------------|-------------------|--|---|--------------------|---------------------|-------|---|
| Param No. | Symbol | Characteristic | Min | Typ ⁽¹⁾ | Max | Units | Conditions |
| | V _{IL} | Input Low Voltage | | | | | |
| DI10 | | I/O Pins | V _{SS} | — | 0.2 V _{DD} | V | |
| DI15 | | $\overline{\text{MCLR}}$ | V _{SS} | — | 0.2 V _{DD} | V | |
| DI16 | | I/O Pins with OSC1 or SOSCI | V _{SS} | — | 0.2 V _{DD} | V | |
| DI18 | | I/O Pins with SDAx, SCLx | V _{SS} | — | 0.3 V _{DD} | V | SMBus disabled |
| DI19 | | I/O Pins with SDAx, SCLx | V _{SS} | — | 0.8 | V | SMBus enabled |
| | V _{IH} | Input High Voltage | | | | | |
| DI20 | | I/O Pins Non 5V Tolerant ⁽⁴⁾ | 0.7 V _{DD} | — | V _{DD} | V | |
| DI21 | | I/O Pins 5V Tolerant ⁽⁴⁾ | 0.7 V _{DD} | — | 5.5 | V | |
| DI28 | | SDAx, SCLx | 0.7 V _{DD} | — | 5.5 | V | SMBus disabled |
| DI29 | | SDAx, SCLx | 2.1 | — | 5.5 | V | SMBus enabled |
| | IC _{NPU} | CNx Pull-up Current | | | | | |
| DI30 | | | — | 250 | — | μA | V _{DD} = 3.3V, V _{PIN} = V _{SS} |
| | I _{IL} | Input Leakage Current^(2,3,4) | | | | | |
| DI50 | | I/O Pins with: 4x Driver Pins: RA0-RA7, RA14, RA15, RB0-RB15, RC1-RC4, RC12-RC14, RD0-RD2, RD8-RD12, RD14, RD15, RE8, RE9, RF0-RF8, RF12, RF13, RG0-RG3, RG6-RG9, RG14, RG15 | — | — | ±2 | μA | V _{SS} ≤ V _{PIN} ≤ V _{DD} , Pin at high-impedance |
| | | 8x Driver Pins: RC15 | — | — | ±4 | μA | V _{SS} ≤ V _{PIN} ≤ V _{DD} , Pin at high-impedance |
| | | 16x Driver Pins: RA9, RA10, RD3-RD7, RD13, RE0-RE7, RG12, RG13 | — | — | ±8 | μA | V _{SS} ≤ V _{PIN} ≤ V _{DD} , Pin at high-impedance |
| DI55 | | $\overline{\text{MCLR}}$ | — | — | ±2 | μA | V _{SS} ≤ V _{PIN} ≤ V _{DD} |
| DI56 | | OSC1 | — | — | ±2 | μA | V _{SS} ≤ V _{PIN} ≤ V _{DD} , XT and HS modes |

- Note 1:** Data in “Typ” column is at 3.3V, +25°C unless otherwise stated.
- 2:** The leakage current on the $\overline{\text{MCLR}}$ pin is strongly dependent on the applied voltage level. The specified levels represent normal operating conditions. Higher leakage current may be measured at different input voltages.
- 3:** Negative current is defined as current sourced by the pin.
- 4:** See “Pin Diagrams” for the list of 5V tolerant I/O pins.
- 5:** V_{IL} source < (V_{SS} – 0.3). Characterized but not tested.
- 6:** Non 5V tolerant pins V_{IH} source > (V_{DD} + 0.3), 5V tolerant pins V_{IH} source > 5.5V. Characterized but not tested.
- 7:** Digital 5V tolerant pins cannot tolerate any “positive” input injection current from input sources > 5.5V.
- 8:** Injection currents > |0| can affect the ADC results by approximately 4-6 counts.
- 9:** Any number and/or combination of I/O pins not excluded under I_{ICL} or I_{ICH} conditions are permitted, provided the mathematical “absolute instantaneous” sum of the input injection currents from all pins do not exceed the specified limit. Characterized but not tested.

dsPIC33FJ32GS406/606/608/610 and dsPIC33FJ64GS406/606/608/610

TABLE 27-9: DC CHARACTERISTICS: I/O PIN INPUT SPECIFICATIONS (CONTINUED)

| DC CHARACTERISTICS | | | Standard Operating Conditions: 3.0V to 3.6V (unless otherwise stated) Operating temperature $-40^{\circ}\text{C} \leq T_A \leq +85^{\circ}\text{C}$ for Industrial $-40^{\circ}\text{C} \leq T_A \leq +125^{\circ}\text{C}$ for Extended | | | | |
|--------------------|------------------|---|---|--------------------|-----------------------|-------|---|
| Param No. | Symbol | Characteristic | Min | Typ ⁽¹⁾ | Max | Units | Conditions |
| DI60a | I _{ICL} | Input Low Injection Current | 0 | — | -5 ^(3,5,8) | mA | All pins except V _{DD} , V _{SS} , AV _{DD} , AV _{SS} , MCLR, V _{CAP} , SOSCI, SOSCO and RB11 |
| DI60b | I _{ICH} | Input High Injection Current | 0 | — | +5 ^(6,7,8) | mA | All pins except V _{DD} , V _{SS} , AV _{DD} , AV _{SS} , MCLR, V _{CAP} , SOSCI, SOSCO, RB11, and digital 5V tolerant designated pins ⁽³⁾ |
| DI60c | $\sum I_{ICT}$ | Total Input Injection Current (sum of all I/O and control pins) | -20 ⁽⁹⁾ | — | +20 ⁽⁹⁾ | mA | Absolute instantaneous sum of all \pm input injection currents from all I/O pins $(I_{ICL} + I_{ICH}) \leq \sum I_{ICT}$ |

- Note 1:** Data in “Typ” column is at 3.3V, +25°C unless otherwise stated.
- 2:** The leakage current on the MCLR pin is strongly dependent on the applied voltage level. The specified levels represent normal operating conditions. Higher leakage current may be measured at different input voltages.
- 3:** Negative current is defined as current sourced by the pin.
- 4:** See “Pin Diagrams” for the list of 5V tolerant I/O pins.
- 5:** V_{IL} source < (V_{SS} – 0.3). Characterized but not tested.
- 6:** Non 5V tolerant pins V_{IH} source > (V_{DD} + 0.3), 5V tolerant pins V_{IH} source > 5.5V. Characterized but not tested.
- 7:** Digital 5V tolerant pins cannot tolerate any “positive” input injection current from input sources > 5.5V.
- 8:** Injection currents > |0| can affect the ADC results by approximately 4-6 counts.
- 9:** Any number and/or combination of I/O pins not excluded under I_{ICL} or I_{ICH} conditions are permitted, provided the mathematical “absolute instantaneous” sum of the input injection currents from all pins do not exceed the specified limit. Characterized but not tested.

TABLE 27-10: DC CHARACTERISTICS: I/O PIN OUTPUT SPECIFICATIONS

| DC CHARACTERISTICS | | | Standard Operating Conditions: 3.0V to 3.6V (unless otherwise stated) Operating temperature -40°C ≤ TA ≤ +85°C for Industrial -40°C ≤ TA ≤ +125°C for Extended | | | | |
|--------------------|--------|---|---|------|------|-------|--|
| Param. | Symbol | Characteristic | Min. | Typ. | Max. | Units | Conditions |
| DO10 | VOL | Output Low Voltage I/O Pins: 4x Sink Driver Pins – RA0-RA7, RA14, RA15, RB0-RB15, RC1-RC4, RC12-RC14, RD0-RD2, RD8-RD12, RD14, RD15, RE8, RE9, RF0-RF8, RF12, RF13, RG0-RG3, RG6-RG9, RG14, RG15 | — | — | 0.4 | V | IOL ≤ 6 mA, VDD = 3.3V See Note 1 |
| | | Output Low Voltage I/O Pins: 8x Sink Driver Pin – RC15 | — | — | 0.4 | V | IOL ≤ 10 mA, VDD = 3.3V See Note 1 |
| | | Output Low Voltage I/O Pins: 16x Sink Driver Pins – RA9, RA10, RD3-RD7, RD13, RE0-RE7, RG12, RG13 | — | — | 0.4 | V | IOL ≤ 18 mA, VDD = 3.3V See Note 1 |
| DO20 | VOH | Output High Voltage I/O Pins: 4x Sink Driver Pins – RA0-RA7, RA14, RA15, RB0-RB15, RC1-RC4, RC12-RC14, RD0-RD2, RD8-RD12, RD14, RD15, RE8, RE9, RF0-RF8, RF12, RF13, RG0-RG3, RG6-RG9, RG14, RG15 | 2.4 | — | — | V | IOH ≥ -6 mA, VDD = 3.3V See Note 1 |
| | | Output High Voltage I/O Pins: 8x Sink Driver Pin – RC15 | 2.4 | — | — | V | IOH ≥ -10 mA, VDD = 3.3V See Note 1 |
| | | Output High Voltage I/O Pins: 16x Sink Driver Pins – RA9, RA10, RD3-RD7, RD13, RE0-RE7, RG12, RG13 | 2.4 | — | — | V | IOH ≥ -18 mA, VDD = 3.3V See Note 1 |

Note 1: Parameters are characterized, but not tested.

TABLE 27-10: DC CHARACTERISTICS: I/O PIN OUTPUT SPECIFICATIONS (CONTINUED)

| DC CHARACTERISTICS | | | Standard Operating Conditions: 3.0V to 3.6V (unless otherwise stated) Operating temperature -40°C ≤ TA ≤ +85°C for Industrial -40°C ≤ TA ≤ +125°C for Extended | | | | |
|--------------------|--------|---|---|------|------|-------|--|
| Param. | Symbol | Characteristic | Min. | Typ. | Max. | Units | Conditions |
| DO20A | VOH1 | Output High Voltage I/O Pins: 4x Sink Driver Pins – RA0-RA7, RA14, RA15, RB0-RB15, RC1-RC4, RC12-RC14, RD0-RD2, RD8-RD12, RD14, RD15, RE8, RE9, RF0-RF8, RF12, RF13, RG0-RG3, RG6-RG9, RG14, RG15 | 1.5 | — | — | V | IOH ≥ -12 mA, VDD = 3.3V See Note 1 |
| | | | 2.0 | — | — | V | IOH ≥ -11 mA, VDD = 3.3V See Note 1 |
| | | | 3.0 | — | — | V | IOH ≥ -3 mA, VDD = 3.3V See Note 1 |
| | | Output High Voltage I/O Pins: 8x Sink Driver Pin – RC15 | 1.5 | — | — | V | IOH ≥ -16 mA, VDD = 3.3V See Note 1 |
| | | | 2.0 | — | — | V | IOH ≥ -12 mA, VDD = 3.3V See Note 1 |
| | | | 3.0 | — | — | V | IOH ≥ -4 mA, VDD = 3.3V See Note 1 |
| | | Output High Voltage I/O Pins: 16x Sink Driver Pins – RA9, RA10, RD3-RD7, RD13, RE0-RE7, RG12, RG13 | 1.5 | — | — | V | IOH ≥ -30 mA, VDD = 3.3V See Note 1 |
| | | | 2.0 | — | — | V | IOH ≥ -25 mA, VDD = 3.3V See Note 1 |
| | | | 3.0 | — | — | V | IOH ≥ -8 mA, VDD = 3.3V See Note 1 |

Note 1: Parameters are characterized, but not tested.

TABLE 27-11: ELECTRICAL CHARACTERISTICS: BROWN-OUT RESET (BOR)

| DC CHARACTERISTICS | | | Standard Operating Conditions: 3.0V to 3.6V ⁽³⁾ (unless otherwise stated) Operating temperature -40°C ≤ TA ≤ +85°C for Industrial -40°C ≤ TA ≤ +125°C for Extended | | | | |
|--------------------|--------|--|--|-----|------|-------|----------------------------|
| Param No. | Symbol | Characteristic | Min ⁽¹⁾ | Typ | Max | Units | Conditions |
| BO10 | VBOR | BOR Event on VDD Transition High-to-Low | 2.6 | — | 2.95 | V | See Note 2 |

Note 1: Parameters are for design guidance only and are not tested in manufacturing.

2: The device will operate as normal until the VDDMIN threshold is reached.

3: Overall functional device operation at VBORMIN < VDD < VDDMIN is tested but not characterized. All device analog modules, such as the ADC, etc., will function but with degraded performance below VDDMIN.

TABLE 27-12: DC CHARACTERISTICS: PROGRAM MEMORY

| DC CHARACTERISTICS | | | Standard Operating Conditions: 3.0V to 3.6V (unless otherwise stated) Operating temperature -40°C ≤ TA ≤ +85°C for Industrial -40°C ≤ TA ≤ +125°C for Extended | | | | |
|-----------------------------|--------|-----------------------------------|---|--------------------|------|-------|--|
| Param No. | Symbol | Characteristic | Min | Typ ⁽¹⁾ | Max | Units | Conditions |
| Program Flash Memory | | | | | | | |
| D130 | EP | Cell Endurance | 10,000 | — | — | E/W | -40°C to +125°C |
| D131 | VPR | VDD for Read | VMIN | — | 3.6 | V | VMIN = Minimum operating voltage |
| D132B | VPEW | VDD for Self-Timed Write | VMIN | — | 3.6 | V | VMIN = Minimum operating voltage |
| D134 | TRETD | Characteristic Retention | 20 | — | — | Year | Provided no other specifications are violated, -40°C to +125°C |
| D135 | IDDP | Supply Current during Programming | — | 10 | — | mA | |
| D136a | TRW | Row Write Time | 1.43 | — | 1.58 | ms | TRW = 11064 FRC cycles, TA = +85°C, See Note 2 |
| D136b | TRW | Row Write Time | 1.39 | — | 1.63 | ms | TRW = 11064 FRC cycles, TA = +125°C, See Note 2 |
| D137a | TPE | Page Erase Time | 21.8 | — | 24.1 | ms | TPE = 168517 FRC cycles, TA = +85°C, See Note 2 |
| D137b | TPE | Page Erase Time | 21.1 | — | 24.8 | ms | TPE = 168517 FRC cycles, TA = +125°C, See Note 2 |
| D138a | TWW | Word Write Cycle Time | 45.8 | — | 50.7 | µs | Tww = 355 FRC cycles, TA = +85°C, See Note 2 |
| D138b | TWW | Word Write Cycle Time | 44.5 | — | 52.3 | µs | Tww = 355 FRC cycles, TA = +125°C, See Note 2 |

Note 1: Data in “Typ” column is at 3.3V, +25°C unless otherwise stated.

- 2:** Other conditions: FRC = 7.37 MHz, TUN<5:0> = b'011111 (for Min.), TUN<5:0> = b'100000 (for Max.). This parameter depends on the FRC accuracy (see [Table 27-20](#)) and the value of the FRC Oscillator Tuning register (see [Register 9-4](#)). For complete details on calculating the minimum and maximum time, see [Section 5.3 “Programming Operations”](#).

TABLE 27-13: INTERNAL VOLTAGE REGULATOR SPECIFICATIONS

| Operating Conditions: -40°C ≤ TA ≤ +85°C for Industrial -40°C ≤ TA ≤ +125°C for Extended | | | | | | | |
|---|--------|--|-----|-----|-----|-------|--|
| Param No. | Symbol | Characteristics | Min | Typ | Max | Units | Comments |
| — | CEFC | External Filter Capacitor Value ⁽¹⁾ | 22 | — | — | µF | Capacitor must be low series resistance (< 0.5 Ohms) |

Note 1: Typical VCAP voltage = 2.5 volts when VDD ≥ VDDMIN.

dsPIC33FJ32GS406/606/608/610 and dsPIC33FJ64GS406/606/608/610

27.2 AC Characteristics and Timing Parameters

This section defines dsPIC33FJ32GS406/606/608/610 and dsPIC33FJ64GS406/606/608/610 AC characteristics and timing parameters.

TABLE 27-14: TEMPERATURE AND VOLTAGE SPECIFICATIONS – AC

| | |
|---------------------------|--|
| AC CHARACTERISTICS | <p>Standard Operating Conditions: 3.0V to 3.6V (unless otherwise stated)</p> <p>Operating temperature $-40^{\circ}\text{C} \leq T_A \leq +85^{\circ}\text{C}$ for Industrial $-40^{\circ}\text{C} \leq T_A \leq +125^{\circ}\text{C}$ for Extended</p> <p>Operating voltage V_{DD} range as described in Section 27.0 “Electrical Characteristics”.</p> |
|---------------------------|--|

FIGURE 27-1: LOAD CONDITIONS FOR DEVICE TIMING SPECIFICATIONS



TABLE 27-15: CAPACITIVE LOADING REQUIREMENTS ON OUTPUT PINS

| Param No. | Symbol | Characteristic | Min | Typ | Max | Units | Conditions |
|-----------|--------|-----------------------|-----|-----|-----|-------|---|
| DO50 | Cosco | OSC2 Pin | — | — | 15 | pF | In XT and HS modes, when external clock is used to drive OSC1 |
| DO56 | Cio | All I/O Pins and OSC2 | — | — | 50 | pF | EC mode |
| DO58 | CB | SCLx, SDAx | — | — | 400 | pF | In I ² C™ mode |

FIGURE 27-2: EXTERNAL CLOCK TIMING



TABLE 27-16: EXTERNAL CLOCK TIMING REQUIREMENTS

| AC CHARACTERISTICS | | | Standard Operating Conditions: 3.0V to 3.6V (unless otherwise stated) Operating temperature -40°C ≤ TA ≤ +85°C for Industrial -40°C ≤ TA ≤ +125°C for Extended | | | | |
|--------------------|---------------|--|---|--------------------|----------------|-------------------|---------------------------|
| Param No. | Symb | Characteristic | Min | Typ ⁽¹⁾ | Max | Units | Conditions |
| OS10 | FIN | External CLKI Frequency (external clocks allowed only in EC and ECPLL modes) | DC | — | 40 | MHz | EC |
| | | Oscillator Crystal Frequency | 3.5 — 10 | — — — | 10 33 40 | MHz kHz MHz | XT SOSC HS |
| OS20 | Tosc | Tosc = 1/Fosc | 12.5 | — | DC | ns | |
| OS25 | Tcy | Instruction Cycle Time ⁽²⁾ | 25 | — | DC | ns | |
| OS30 | TosL, TosH | External Clock in (OSC1) High or Low Time | 0.375 x TOSC | — | 0.625 x TOSC | ns | EC |
| OS31 | TosR, TosF | External Clock in (OSC1) Rise or Fall Time | — | — | 20 | ns | EC |
| OS40 | TckR | CLKO Rise Time ⁽³⁾ | — | 5.2 | — | ns | |
| OS41 | TckF | CLKO Fall Time ⁽³⁾ | — | 5.2 | — | ns | |
| OS41 | GM | External Oscillator Transconductance | 14 | 16 | 18 | mA/V | VDD = 3.3V, TA = +25°C |

Note 1: Data in “Typ” column is at 3.3V, +25°C unless otherwise stated.

2: Instruction cycle period (Tcy) equals two times the input oscillator time base period. All specified values are based on characterization data for that particular oscillator type, under standard operating conditions, with the device executing code. Exceeding these specified limits may result in an unstable oscillator operation and/or higher than expected current consumption. All devices are tested to operate at “min.” values with an external clock applied to the OSC1/CLKI pin. When an external clock input is used, the “max.” cycle time limit is “DC” (no clock) for all devices.

3: Measurements are taken in EC mode. The CLKO signal is measured on the OSC2 pin.

dsPIC33FJ32GS406/606/608/610 and dsPIC33FJ64GS406/606/608/610

TABLE 27-17: PLL CLOCK TIMING SPECIFICATIONS (V_{DD} = 3.0V TO 3.6V)

| AC CHARACTERISTICS | | | Standard Operating Conditions: 3.0V to 3.6V (unless otherwise stated) Operating temperature -40°C ≤ TA ≤ +85°C for Industrial -40°C ≤ TA ≤ +125°C for Extended | | | | |
|--------------------|-------------------|---|---|--------------------|-----|-------|-----------------------------|
| Param No. | Symbol | Characteristic | Min | Typ ⁽¹⁾ | Max | Units | Conditions |
| OS50 | FPLLI | PLL Voltage Controlled Oscillator (VCO) Input Frequency Range | 0.8 | — | 8 | MHz | ECPLL, XTPLL modes |
| OS51 | F _{SYS} | On-Chip VCO System Frequency | 100 | — | 200 | MHz | |
| OS52 | T _{LOCK} | PLL Start-up Time (Lock Time) | 0.9 | 1.5 | 3.1 | mS | |
| OS53 | D _{CLK} | CLKO Stability (Jitter) ⁽²⁾ | -3 | 0.5 | 3 | % | Measured over 100 ms period |

Note 1: Data in “Typ” column is at 3.3V, +25°C unless otherwise stated. Parameters are for design guidance only and are not tested in manufacturing.

2: These parameters are characterized by similarity, but are not tested in manufacturing. This specification is based on clock cycle by clock cycle measurements. To calculate the effective jitter for individual time bases or communication clocks, use this formula:

$$\text{Peripheral Clock Jitter} = \frac{DCLK}{\sqrt{\left(\frac{FOSC}{\text{Peripheral Bit Rate Clock}}\right)}}$$

For example: F_{OSC} = 32 MHz, D_{CLK} = 3%, SPI bit rate clock, (i.e., SCK) is 2 MHz.

$$\text{SPI SCK Jitter} = \left[\frac{DCLK}{\sqrt{\left(\frac{32 \text{ MHz}}{2 \text{ MHz}}\right)}} \right] = \left[\frac{3\%}{\sqrt{16}} \right] = \left[\frac{3\%}{4} \right] = 0.75\%$$

TABLE 27-18: AUXILIARY PLL CLOCK TIMING SPECIFICATIONS (V_{DD} = 3.0V TO 3.6V)

| AC CHARACTERISTICS | | | Standard Operating Conditions: 3.0V to 3.6V (unless otherwise stated) Operating temperature -40°C ≤ TA ≤ +85°C for Industrial -40°C ≤ TA ≤ +125°C for Extended | | | | |
|--------------------|--------------------|---|--|--------------------|-----|-------|------------|
| Param No. | Symbol | Characteristic | Min | Typ ⁽¹⁾ | Max | Units | Conditions |
| OS56 | F _{HPOUT} | On-Chip, 16x PLL CCO Frequency | 112 | 118 | 120 | MHz | |
| OS57 | F _{HPIN} | On-Chip, 16x PLL Phase Detector Input Frequency | 7.0 | 7.37 | 7.5 | MHz | |
| OS58 | T _{SU} | Frequency Generator Lock Time | — | — | 10 | μs | |

Note 1: Data in “Typ” column is at 3.3V, +25°C unless otherwise stated. Parameters are for design guidance only and are not tested in manufacturing.

TABLE 27-19: AC CHARACTERISTICS: INTERNAL FRC ACCURACY

| AC CHARACTERISTICS | | Standard Operating Conditions: 3.0V to 3.6V (unless otherwise stated) Operating temperature -40°C ≤ TA ≤ +85°C for industrial -40°C ≤ TA ≤ +125°C for Extended | | | | | |
|---|----------------|--|-----|-----|-------|---------------------|----------------|
| Param No. | Characteristic | Min | Typ | Max | Units | Conditions | |
| Internal FRC Accuracy @ FRC Frequency = 7.37 MHz⁽¹⁾ | | | | | | | |
| F20a | FRC | -1 | — | +1 | % | -40°C ≤ TA ≤ +85°C | VDD = 3.0-3.6V |
| F20b | FRC | -2 | — | +2 | % | -40°C ≤ TA ≤ +125°C | VDD = 3.0-3.6V |

Note 1: Frequency calibrated at +25°C and 3.3V. The TUN<5:0> bits can be used to compensate for temperature drift.

TABLE 27-20: AC CHARACTERISTICS: INTERNAL LPRC ACCURACY

| AC CHARACTERISTICS | | Standard Operating Conditions: 3.0V to 3.6V (unless otherwise stated) Operating temperature -40°C ≤ TA ≤ +85°C for Industrial -40°C ≤ TA ≤ +125°C for Extended | | | | | |
|--|----------------|--|-----|-----|-------|---------------------|--|
| Param No. | Characteristic | Min | Typ | Max | Units | Conditions | |
| LPRC @ 32.768 kHz⁽¹⁾ | | | | | | | |
| F21a | LPRC | -40 | — | +40 | % | -40°C ≤ TA ≤ +85°C | |
| F21b | LPRC | -70 | — | +70 | % | -40°C ≤ TA ≤ +125°C | |

Note 1: Change of LPRC frequency as VDD changes.

FIGURE 27-3: I/O TIMING CHARACTERISTICS

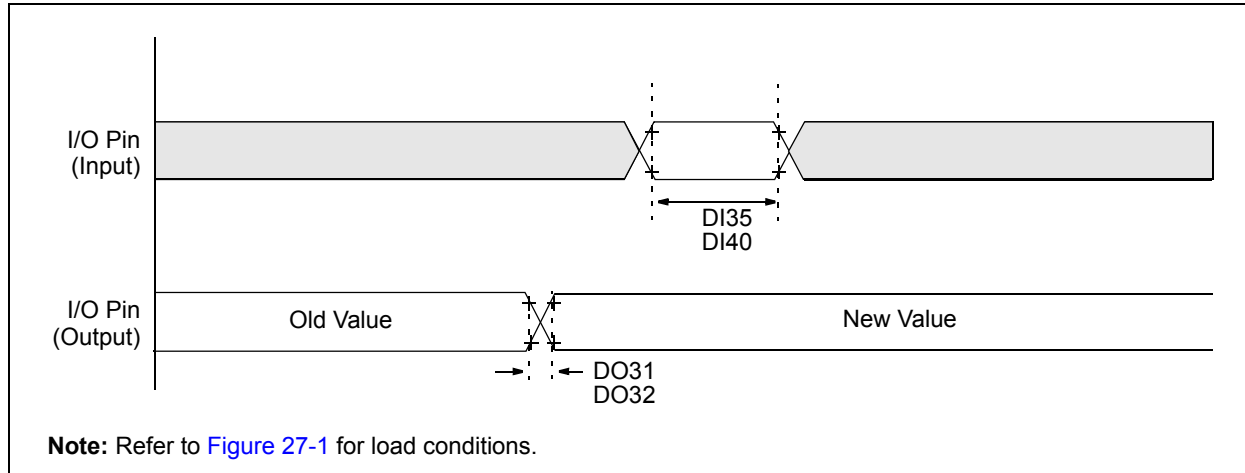

TABLE 27-21: I/O TIMING REQUIREMENTS

| AC CHARACTERISTICS | | | Standard Operating Conditions: 3.0V to 3.6V (unless otherwise stated) Operating temperature $-40^{\circ}\text{C} \leq T_A \leq +85^{\circ}\text{C}$ for Industrial $-40^{\circ}\text{C} \leq T_A \leq +125^{\circ}\text{C}$ for Extended | | | | |
|--------------------|--------|---|---|--------------------|-----|-------|--|
| Param No. | Symbol | Characteristic | Min | Typ ⁽¹⁾ | Max | Units | Conditions |
| DO31 | TioR | Port Output Rise Time | | | | | Refer to Figure 27-1 for test conditions |
| | | 4x Source Driver Pins – RA0-RA7, RA14, RA15, RB0-RB15, RC1-RC4, RC12-RC14, RD0-RD2, RD8-RD12, RD14, RD15, RE8, RE9, RF0-RF8, RF12, RF13, RG0-RG3, RG6-RG9, RG14, RG15 | — | 10 | 25 | ns | |
| | | 8x Source Driver Pins – RC15 | — | 8 | 20 | ns | |
| | | 16x Source Driver Pins – RE0-RE7, RG12, RG13 | — | 6 | 15 | ns | |
| DO32 | TioF | Port Output Fall Time | | | | | Refer to Figure 27-1 for test conditions |
| | | 4x Source Driver Pins – RA0-RA7, RA14, RA15, RB0-RB15, RC1-RC4, RC12-RC14, RD0-RD2, RD8-RD12, RD14, RD15, RE8, RE9, RF0-RF8, RF12, RF13, RG0-RG3, RG6-RG9, RG14, RG15 | — | 10 | 25 | ns | |
| | | 8x Source Driver Pins – RC15 | — | 8 | 20 | ns | |
| | | 16x Source Driver Pins – RE0-RE7, RG12, RG13 | — | 6 | 15 | ns | |
| DI35 | TINP | INTx Pin High or Low Time (input) | 20 | — | — | ns | |
| DI40 | TRBP | CNx High or Low Time (input) | 2 | — | — | Tcy | |

Note 1: Data in “Typ” column is at 3.3V, +25°C unless otherwise stated.

FIGURE 27-4: RESET, WATCHDOG TIMER, OSCILLATOR START-UP TIMER AND POWER-UP TIMER TIMING CHARACTERISTICS



dsPIC33FJ32GS406/606/608/610 and dsPIC33FJ64GS406/606/608/610

TABLE 27-22: RESET, WATCHDOG TIMER, OSCILLATOR START-UP TIMER, POWER-UP TIMER TIMING REQUIREMENTS

| AC CHARACTERISTICS | | | Standard Operating Conditions: 3.0V to 3.6V (unless otherwise stated) Operating temperature -40°C ≤ TA ≤ +85°C for Industrial -40°C ≤ TA ≤ +125°C for Extended | | | | |
|--------------------|--------|--|---|--------------------------------------|-----|-------|--|
| Param No. | Symbol | Characteristic ⁽¹⁾ | Min | Typ ⁽²⁾ | Max | Units | Conditions |
| SY10 | TMCL | MCLR Pulse Width (low) | 2 | — | — | μs | -40°C to +85°C |
| SY11 | TPWRT | Power-up Timer Period | — | 2 4 8 16 32 64 128 | — | ms | -40°C to +85°C User programmable |
| SY12 | TPOR | Power-on Reset Delay | 3 | 10 | 30 | μs | -40°C to +85°C |
| SY13 | TIOZ | I/O High-Impedance from MCLR Low or Watchdog Timer Reset | 0.68 | 0.72 | 1.2 | μs | |
| SY20 | TWDT1 | Watchdog Timer Time-out Period | — | — | — | ms | See Section 24.4 “Watchdog Timer (WDT)” and LPRC Parameter F21a (Table 27-20). |
| SY30 | TOST | Oscillator Start-up Time | — | 1024 TOSC | — | — | TOSC = OSC1 period |

Note 1: These parameters are characterized but not tested in manufacturing.

Note 2: Data in “Typ” column is at 3.3V, +25°C unless otherwise stated.

FIGURE 27-5: TIMER1/2/3 EXTERNAL CLOCK TIMING CHARACTERISTICS



Note: Refer to Figure 27-1 for load conditions.

TABLE 27-23: TIMER1 EXTERNAL CLOCK TIMING REQUIREMENTS⁽¹⁾

| AC CHARACTERISTICS | | | Standard Operating Conditions: 3.0V to 3.6V (unless otherwise stated) Operating temperature -40°C ≤ TA ≤ +85°C for Industrial -40°C ≤ TA ≤ +125°C for Extended | | | | | |
|--------------------|-----------|---|---|------------|---------------|-------|------------|---|
| Param No. | Symbol | Characteristic | Min | Typ | Max | Units | Conditions | |
| TA10 | TtxH | T1CK High Time | Synchronous, no prescaler | Tcy + 20 | — | — | ns | Must also meet Parameter TA15, N = prescale value (1, 8, 64, 256) |
| | | Synchronous, with prescaler | (Tcy + 20)/N | — | — | ns | | |
| | | Asynchronous | 20 | — | — | ns | | |
| TA11 | TtxL | T1CK Low Time | Synchronous, no prescaler | (Tcy + 20) | — | — | ns | Must also meet Parameter TA15, N = prescale value (1, 8, 64, 256) |
| | | Synchronous, with prescaler | (Tcy + 20)/N | — | — | ns | | |
| | | Asynchronous | 20 | — | — | ns | | |
| TA15 | TtxP | T1CK Input Period | Synchronous, no prescaler | 2 Tcy + 40 | — | — | ns | N = prescale value (1, 8, 64, 256) |
| | | Synchronous, with prescaler | Greater of: 40 ns or (2 Tcy + 40)/N | — | — | — | | |
| | | Asynchronous | 40 | — | — | ns | | |
| OS60 | Ft1 | SOSCI/T1CK Oscillator Input Frequency Range (oscillator enabled by setting bit, TCS (T1CON<1>)) | DC | — | 50 | kHz | | |
| TA20 | TCKEXTMRL | Delay from External T1CK Clock Edge to Timer Increment | 0.75 Tcy + 40 | — | 1.75 Tcy + 40 | — | | |

Note 1: Timer1 is a Type A.

dsPIC33FJ32GS406/606/608/610 and dsPIC33FJ64GS406/606/608/610

TABLE 27-24: TIMER2/4 EXTERNAL CLOCK TIMING REQUIREMENTS

| AC CHARACTERISTICS | | | | Standard Operating Conditions: 3.0V to 3.6V (unless otherwise stated) Operating temperature $-40^{\circ}\text{C} \leq T_A \leq +85^{\circ}\text{C}$ for Industrial $-40^{\circ}\text{C} \leq T_A \leq +125^{\circ}\text{C}$ for Extended | | | | |
|--------------------|-----------|--|------------------|---|-----|---------------|-------|---|
| Param No. | Symbol | Characteristic ⁽¹⁾ | | Min | Typ | Max | Units | Conditions |
| TB10 | TtxH | TxCK High Time | Synchronous mode | Greater of: 20 or (Tcy + 20)/N | — | — | ns | Must also meet Parameter TB15, N = prescale value (1, 8, 64, 256) |
| TB11 | TtxL | TxCK Low Time | Synchronous mode | Greater of: 20 or (Tcy + 20)/N | — | — | ns | Must also meet Parameter TB15, N = prescale value (1, 8, 64, 256) |
| TB15 | TtxP | TxCK Input Period | Synchronous mode | Greater of: 40 or (2 Tcy + 40)/N | — | — | ns | N = prescale value (1, 8, 64, 256) |
| TB20 | TCKEXTMRL | Delay from External TxCK Clock Edge to Timer Increment | | 0.75 Tcy + 40 | — | 1.75 Tcy + 40 | ns | |

Note 1: These parameters are characterized, but are not tested in manufacturing.

TABLE 27-25: TIMER3/5 EXTERNAL CLOCK TIMING REQUIREMENTS

| AC CHARACTERISTICS | | | | Standard Operating Conditions: 3.0V to 3.6V (unless otherwise stated) Operating temperature $-40^{\circ}\text{C} \leq T_A \leq +85^{\circ}\text{C}$ for Industrial $-40^{\circ}\text{C} \leq T_A \leq +125^{\circ}\text{C}$ for Extended | | | | |
|--------------------|-----------|--|-----------------------------|---|-----|---------------|-------|-------------------------------|
| Param No. | Symbol | Characteristic ⁽¹⁾ | | Min | Typ | Max | Units | Conditions |
| TC10 | TtxH | TxCK High Time | Synchronous | Tcy + 20 | — | — | ns | Must also meet Parameter TC15 |
| TC11 | TtxL | TxCK Low Time | Synchronous | Tcy + 20 | — | — | ns | Must also meet Parameter TC15 |
| TC15 | TtxP | TxCK Input Period | Synchronous, with prescaler | 2 Tcy + 40 | — | — | ns | |
| TC20 | TCKEXTMRL | Delay from External TxCK Clock Edge to Timer Increment | | 0.75 Tcy + 40 | — | 1.75 Tcy + 40 | ns | |

Note 1: These parameters are characterized, but are not tested in manufacturing.

FIGURE 27-6: INPUT CAPTURE x (ICx) TIMING CHARACTERISTICS



TABLE 27-26: INPUT CAPTURE x TIMING REQUIREMENTS

| AC CHARACTERISTICS | | | | Standard Operating Conditions: 3.0V to 3.6V (unless otherwise stated) Operating temperature $-40^{\circ}\text{C} \leq T_A \leq +85^{\circ}\text{C}$ for Industrial $-40^{\circ}\text{C} \leq T_A \leq +125^{\circ}\text{C}$ for Extended | | | |
|--------------------|--------|-------------------------------|----------------|---|-----|-------|-------------------------------|
| Param No. | Symbol | Characteristic ⁽¹⁾ | | Min | Max | Units | Conditions |
| IC10 | TccL | ICx Input Low Time | No prescaler | $0.5 T_{CY} + 20$ | — | ns | |
| | | | With prescaler | 10 | — | ns | |
| IC11 | TccH | ICx Input High Time | No prescaler | $0.5 T_{CY} + 20$ | — | ns | |
| | | | With prescaler | 10 | — | ns | |
| IC15 | TccP | ICx Input Period | | $(T_{CY} + 40)/N$ | — | ns | N = prescale value (1, 4, 16) |

Note 1: These parameters are characterized but not tested in manufacturing.

FIGURE 27-7: OUTPUT COMPARE x (OCx) MODULE TIMING CHARACTERISTICS



TABLE 27-27: OUTPUT COMPARE x MODULE TIMING REQUIREMENTS

| AC CHARACTERISTICS | | | | Standard Operating Conditions: 3.0V to 3.6V (unless otherwise stated) Operating temperature $-40^{\circ}\text{C} \leq T_A \leq +85^{\circ}\text{C}$ for Industrial $-40^{\circ}\text{C} \leq T_A \leq +125^{\circ}\text{C}$ for Extended | | | | |
|--------------------|--------|-------------------------------|--|---|-----|-----|-------|--------------------|
| Param No. | Symbol | Characteristic ⁽¹⁾ | | Min | Typ | Max | Units | Conditions |
| OC10 | TccF | OCx Output Fall Time | | — | — | — | ns | See Parameter DO32 |
| OC11 | TccR | OCx Output Rise Time | | — | — | — | ns | See Parameter DO31 |

Note 1: These parameters are characterized but not tested in manufacturing.

FIGURE 27-8: OUTPUT COMPARE x/PWMx MODULE TIMING CHARACTERISTICS

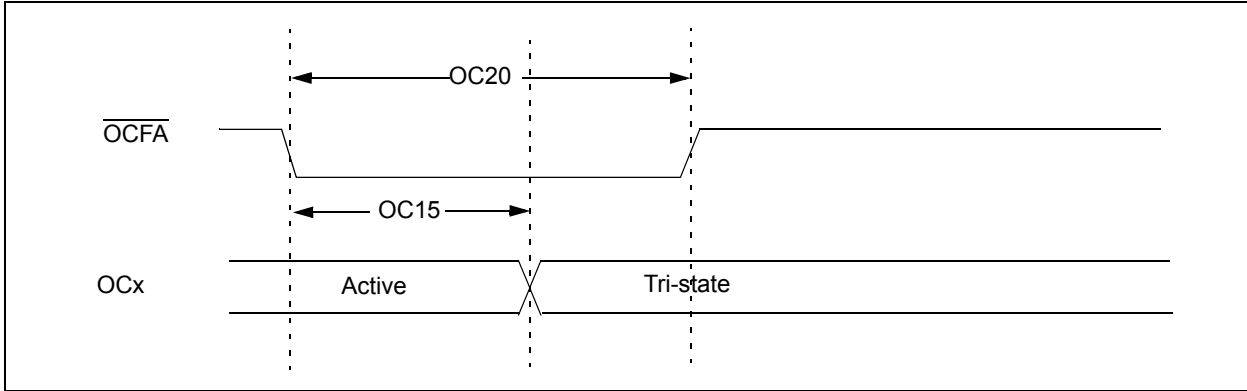

TABLE 27-28: SIMPLE OCx/PWMx MODE TIMING REQUIREMENTS

| AC CHARACTERISTICS | | | Standard Operating Conditions: 3.0V to 3.6V (unless otherwise stated) Operating temperature $-40^{\circ}\text{C} \leq T_A \leq +85^{\circ}\text{C}$ for Industrial $-40^{\circ}\text{C} \leq T_A \leq +125^{\circ}\text{C}$ for Extended | | | | |
|--------------------|--------|-------------------------------|---|-----|---------------|-------|------------|
| Param No. | Symbol | Characteristic ⁽¹⁾ | Min | Typ | Max | Units | Conditions |
| OC15 | TFD | Fault Input to PWM I/O Change | — | — | $T_{CY} + 20$ | ns | |
| OC20 | TFLT | Fault Input Pulse Width | $T_{CY} + 20$ | — | — | ns | |

Note 1: These parameters are characterized but not tested in manufacturing.

FIGURE 27-9: HIGH-SPEED PWMx MODULE FAULT TIMING CHARACTERISTICS



FIGURE 27-10: HIGH-SPEED PWMx MODULE TIMING CHARACTERISTICS



TABLE 27-29: HIGH-SPEED PWMx MODULE TIMING REQUIREMENTS

| AC CHARACTERISTICS | | | Standard Operating Conditions: 3.0V to 3.6V (unless otherwise stated) Operating temperature $-40^{\circ}\text{C} \leq T_A \leq +85^{\circ}\text{C}$ for Industrial $-40^{\circ}\text{C} \leq T_A \leq +125^{\circ}\text{C}$ for Extended | | | | |
|--------------------|-------------------|---|---|-----|-----|-------|-------------------|
| Param No. | Symbol | Characteristic ⁽¹⁾ | Min | Typ | Max | Units | Conditions |
| MP10 | T _{FPWM} | PWMx Output Fall Time | — | 2.5 | — | ns | |
| MP11 | T _{RPWM} | PWMx Output Rise Time | — | 2.5 | — | ns | |
| MP20 | T _{FD} | Fault Input \downarrow to PWMx I/O Change | — | — | 15 | ns | DTC<10> = 10 |
| MP30 | T _{FH} | Minimum PWMx Fault Pulse Width | 8 | — | — | ns | |
| MP31 | T _{PDLY} | Tap Delay | 1.04 | — | — | ns | ACLK = 120 MHz |
| MP32 | ACLK | PWMx Input Clock | — | — | 120 | MHz | See Note 2 |

Note 1: These parameters are characterized but not tested in manufacturing.

Note 2: This parameter is a maximum allowed input clock for the PWM module.

TABLE 27-30: SPIx MAXIMUM DATA/CLOCK RATE SUMMARY

| AC CHARACTERISTICS | | | Standard Operating Conditions: 3.0V to 3.6V (unless otherwise stated) Operating temperature -40°C ≤ TA ≤ +85°C for Industrial -40°C ≤ TA ≤ +125°C for Extended | | | |
|--------------------|------------------------------------|---------------------------------------|---|-----|-----|-----|
| Maximum Data Rate | Master Transmit Only (Half-Duplex) | Master Transmit/Receive (Full-Duplex) | Slave Transmit/Receive (Full-Duplex) | CKE | CKP | SMP |
| 15 MHz | Table 27-31 | — | — | 0,1 | 0,1 | 0,1 |
| 10 MHz | — | Table 27-32 | — | 1 | 0,1 | 1 |
| 10 MHz | — | Table 27-33 | — | 0 | 0,1 | 1 |
| 15 MHz | — | — | Table 27-34 | 1 | 0 | 0 |
| 11 MHz | — | — | Table 27-35 | 1 | 1 | 0 |
| 15 MHz | — | — | Table 27-36 | 0 | 1 | 0 |
| 11 MHz | — | — | Table 27-37 | 0 | 0 | 0 |

FIGURE 27-11: SPIx MASTER MODE (HALF-DUPLEX, TRANSMIT ONLY, CKE = 0) TIMING CHARACTERISTICS

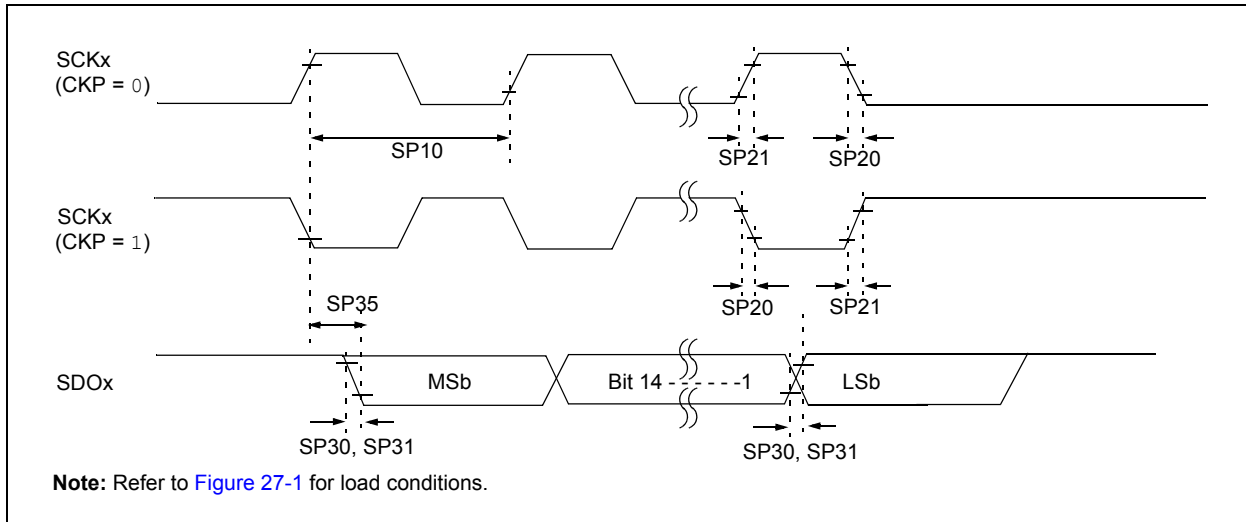

FIGURE 27-12: SPIx MASTER MODE (HALF-DUPLEX, TRANSMIT ONLY, CKE = 1) TIMING CHARACTERISTICS



TABLE 27-31: SPIx MASTER MODE (HALF-DUPLEX, TRANSMIT ONLY) TIMING REQUIREMENTS

| AC CHARACTERISTICS | | | Standard Operating Conditions: 3.0V to 3.6V (unless otherwise stated) Operating temperature -40°C ≤ TA ≤ +85°C for Industrial -40°C ≤ TA ≤ +125°C for Extended | | | | |
|--------------------|-----------------------|---|---|--------------------|-----|-------|---|
| Param No. | Symbol | Characteristic ⁽¹⁾ | Min | Typ ⁽²⁾ | Max | Units | Conditions |
| SP10 | TscP | Maximum SCKx Frequency | — | — | 15 | MHz | See Note 3 |
| SP20 | TscF | SCKx Output Fall Time | — | — | — | ns | See Parameter DO32 and Note 4 |
| SP21 | TscR | SCKx Output Rise Time | — | — | — | ns | See Parameter DO31 and Note 4 |
| SP30 | TdoF | SDOx Data Output Fall Time | — | — | — | ns | See Parameter DO32 and Note 4 |
| SP31 | TdoR | SDOx Data Output Rise Time | — | — | — | ns | See Parameter DO31 and Note 4 |
| SP35 | TscH2doV, TscL2doV | SDOx Data Output Valid after SCKx Edge | — | 6 | 20 | ns | |
| SP36 | TdiV2scH, TdiV2scL | SDOx Data Output Setup to First SCKx Edge | 30 | — | — | ns | |

- Note 1:** These parameters are characterized, but are not tested in manufacturing.
- 2:** Data in “Typ” column is at 3.3V, +25°C unless otherwise stated.
- 3:** The minimum clock period for SCKx is 66.7 ns. Therefore, the clock generated in Master mode must not violate this specification.
- 4:** Assumes 50 pF load on all SPIx pins.

FIGURE 27-13: SPIx MASTER MODE (FULL-DUPLEX, CKE = 1, CKP = x, SMP = 1) TIMING CHARACTERISTICS



TABLE 27-32: SPIx MASTER MODE (FULL-DUPLEX, CKE = 1, CKP = x, SMP = 1) TIMING REQUIREMENTS

| AC CHARACTERISTICS | | | Standard Operating Conditions: 3.0V to 3.6V (unless otherwise stated) Operating temperature -40°C ≤ TA ≤ +85°C for Industrial -40°C ≤ TA ≤ +125°C for Extended | | | | |
|--------------------|-----------------------|--|---|--------------------|-----|-------|---|
| Param No. | Symbol | Characteristic ⁽¹⁾ | Min | Typ ⁽²⁾ | Max | Units | Conditions |
| SP10 | TscP | Maximum SCKx Frequency | — | — | 10 | MHz | See Note 3 |
| SP20 | TscF | SCKx Output Fall Time | — | — | — | ns | See Parameter DO32 and Note 4 |
| SP21 | TscR | SCKx Output Rise Time | — | — | — | ns | See Parameter DO31 and Note 4 |
| SP30 | TdoF | SDOx Data Output Fall Time | — | — | — | ns | See Parameter DO32 and Note 4 |
| SP31 | TdoR | SDOx Data Output Rise Time | — | — | — | ns | See Parameter DO31 and Note 4 |
| SP35 | Tsch2doV, TscL2doV | SDOx Data Output Valid after SCKx Edge | — | 6 | 20 | ns | |
| SP36 | TdoV2sc, TdoV2scL | SDOx Data Output Setup to First SCKx Edge | 30 | — | — | ns | |
| SP40 | TdiV2sch, TdiV2scL | Setup Time of SDIx Data Input to SCKx Edge | 30 | — | — | ns | |
| SP41 | Tsch2diL, TscL2diL | Hold Time of SDIx Data Input to SCKx Edge | 30 | — | — | ns | |

- Note 1:** These parameters are characterized, but are not tested in manufacturing.
Note 2: Data in “Typ” column is at 3.3V, +25°C unless otherwise stated.
Note 3: The minimum clock period for SCKx is 100 ns. The clock generated in Master mode must not violate this specification.
Note 4: Assumes 50 pF load on all SPIx pins.

FIGURE 27-14: SPIx MASTER MODE (FULL-DUPLEX, CKE = 0, CKP = x, SMP = 1) TIMING CHARACTERISTICS



TABLE 27-33: SPIx MASTER MODE (FULL-DUPLEX, CKE = 0, CKP = x, SMP = 1) TIMING REQUIREMENTS

| AC CHARACTERISTICS | | | Standard Operating Conditions: 3.0V to 3.6V (unless otherwise stated) Operating temperature -40°C ≤ TA ≤ +85°C for Industrial -40°C ≤ TA ≤ +125°C for Extended | | | | |
|--------------------|-----------------------|--|---|--------------------|-----|-------|---|
| Param No. | Symbol | Characteristic ⁽¹⁾ | Min | Typ ⁽²⁾ | Max | Units | Conditions |
| SP10 | TscP | Maximum SCKx Frequency | — | — | 10 | MHz | -40°C to +125°C and see Note 3 |
| SP20 | TscF | SCKx Output Fall Time | — | — | — | ns | See Parameter DO32 and Note 4 |
| SP21 | TscR | SCKx Output Rise Time | — | — | — | ns | See Parameter DO31 and Note 4 |
| SP30 | TdoF | SDOx Data Output Fall Time | — | — | — | ns | See Parameter DO32 and Note 4 |
| SP31 | TdoR | SDOx Data Output Rise Time | — | — | — | ns | See Parameter DO31 and Note 4 |
| SP35 | Tsch2doV, TscL2doV | SDOx Data Output Valid after SCKx Edge | — | 6 | 20 | ns | |
| SP36 | TdoV2scH, TdoV2scL | SDOx Data Output Setup to First SCKx Edge | 30 | — | — | ns | |
| SP40 | TdiV2scH, TdiV2scL | Setup Time of SDIx Data Input to SCKx Edge | 30 | — | — | ns | |
| SP41 | Tsch2diL, TscL2diL | Hold Time of SDIx Data Input to SCKx Edge | 30 | — | — | ns | |

Note 1: These parameters are characterized, but are not tested in manufacturing.

2: Data in “Typ” column is at 3.3V, +25°C unless otherwise stated.

3: The minimum clock period for SCKx is 100 ns. The clock generated in Master mode must not violate this specification.

4: Assumes 50 pF load on all SPIx pins.

FIGURE 27-15: SPIx SLAVE MODE (FULL-DUPLEX, CKE = 1, CKP = 0, SMP = 0) TIMING CHARACTERISTICS



TABLE 27-34: SPIx SLAVE MODE (FULL-DUPLEX, CKE = 1, CKP = 0, SMP = 0) TIMING REQUIREMENTS

| AC CHARACTERISTICS | | | Standard Operating Conditions: 3.0V to 3.6V (unless otherwise stated) Operating temperature -40°C ≤ TA ≤ +85°C for Industrial -40°C ≤ TA ≤ +125°C for Extended | | | | |
|--------------------|-----------------------|--|---|--------------------|-----|-------|---|
| Param No. | Symbol | Characteristic ⁽¹⁾ | Min | Typ ⁽²⁾ | Max | Units | Conditions |
| SP70 | TscP | Maximum SCKx Input Frequency | — | — | 15 | MHz | See Note 3 |
| SP72 | TscF | SCKx Input Fall Time | — | — | — | ns | See Parameter DO32 and Note 4 |
| SP73 | TscR | SCKx Input Rise Time | — | — | — | ns | See Parameter DO31 and Note 4 |
| SP30 | TdoF | SDOx Data Output Fall Time | — | — | — | ns | See Parameter DO32 and Note 4 |
| SP31 | TdoR | SDOx Data Output Rise Time | — | — | — | ns | See Parameter DO31 and Note 4 |
| SP35 | Tsch2doV, TscL2doV | SDOx Data Output Valid after SCKx Edge | — | 6 | 20 | ns | |
| SP36 | TdoV2scH, TdoV2scL | SDOx Data Output Setup to First SCKx Edge | 30 | — | — | ns | |
| SP40 | TdiV2scH, TdiV2scL | Setup Time of SDIx Data Input to SCKx Edge | 30 | — | — | ns | |
| SP41 | Tsch2diL, TscL2diL | Hold Time of SDIx Data Input to SCKx Edge | 30 | — | — | ns | |
| SP50 | TssL2scH, TssL2scL | $\overline{SSx} \downarrow$ to SCKx \uparrow or SCKx Input | 120 | — | — | ns | |
| SP51 | TssH2doZ | $\overline{SSx} \uparrow$ to SDOx Output High-Impedance | 10 | — | 50 | ns | See Note 4 |
| SP52 | Tsch2ssH TscL2ssH | \overline{SSx} after SCKx Edge | 1.5 Tcy + 40 | — | — | ns | See Note 4 |
| SP60 | TssL2doV | SDOx Data Output Valid after \overline{SSx} Edge | — | — | 50 | ns | |

- Note 1:** These parameters are characterized, but are not tested in manufacturing.
- Note 2:** Data in “Typ” column is at 3.3V, +25°C unless otherwise stated.
- Note 3:** The minimum clock period for SCKx is 66.7 ns. Therefore, the SCKx clock, generated by the master, must not violate this specification.
- Note 4:** Assumes 50 pF load on all SPIx pins.

FIGURE 27-16: SPIx SLAVE MODE (FULL-DUPLEX, CKE = 1, CKP = 1, SMP = 0) TIMING CHARACTERISTICS



TABLE 27-35: SPIx SLAVE MODE (FULL-DUPLEX, CKE = 1, CKP = 1, SMP = 0) TIMING REQUIREMENTS

| AC CHARACTERISTICS | | | Standard Operating Conditions: 3.0V to 3.6V (unless otherwise stated) Operating temperature $-40^{\circ}\text{C} \leq T_A \leq +85^{\circ}\text{C}$ for Industrial $-40^{\circ}\text{C} \leq T_A \leq +125^{\circ}\text{C}$ for Extended | | | | |
|--------------------|-----------------------|---|---|--------------------|-----|-------|---|
| Param No. | Symbol | Characteristic ⁽¹⁾ | Min | Typ ⁽²⁾ | Max | Units | Conditions |
| SP70 | TscP | Maximum SCKx Input Frequency | — | — | 11 | MHz | See Note 3 |
| SP72 | TscF | SCKx Input Fall Time | — | — | — | ns | See Parameter DO32 and Note 4 |
| SP73 | TscR | SCKx Input Rise Time | — | — | — | ns | See Parameter DO31 and Note 4 |
| SP30 | TdoF | SDOx Data Output Fall Time | — | — | — | ns | See Parameter DO32 and Note 4 |
| SP31 | TdoR | SDOx Data Output Rise Time | — | — | — | ns | See Parameter DO31 and Note 4 |
| SP35 | Tsch2doV, TscL2doV | SDOx Data Output Valid after SCKx Edge | — | 6 | 20 | ns | |
| SP36 | TdoV2scH, TdoV2scL | SDOx Data Output Setup to First SCKx Edge | 30 | — | — | ns | |
| SP40 | TdiV2scH, TdiV2scL | Setup Time of SDIx Data Input to SCKx Edge | 30 | — | — | ns | |
| SP41 | Tsch2diL, TscL2diL | Hold Time of SDIx Data Input to SCKx Edge | 30 | — | — | ns | |
| SP50 | TssL2scH, TssL2scL | $\overline{\text{SSx}} \downarrow$ to SCKx \uparrow or SCKx Input | 120 | — | — | ns | |
| SP51 | TssH2doZ | $\overline{\text{SSx}} \uparrow$ to SDOx Output High-Impedance | 10 | — | 50 | ns | See Note 4 |
| SP52 | Tsch2ssH TscL2ssH | $\overline{\text{SSx}}$ after SCKx Edge | $1.5 T_{CY} + 40$ | — | — | ns | See Note 4 |
| SP60 | TssL2doV | SDOx Data Output Valid after $\overline{\text{SSx}}$ Edge | — | — | 50 | ns | |

Note 1: These parameters are characterized, but are not tested in manufacturing.

2: Data in “Typ” column is at 3.3V, +25°C unless otherwise stated.

3: The minimum clock period for SCKx is 91 ns. Therefore, the SCKx clock, generated by the master, must not violate this specification.

4: Assumes 50 pF load on all SPIx pins.

FIGURE 27-17: SPIx SLAVE MODE (FULL-DUPLEX, CKE = 0, CKP = 1, SMP = 0) TIMING CHARACTERISTICS



TABLE 27-36: SPIx SLAVE MODE (FULL-DUPLEX, CKE = 0, CKP = 1, SMP = 0) TIMING REQUIREMENTS

| AC CHARACTERISTICS | | | Standard Operating Conditions: 3.0V to 3.6V (unless otherwise stated) Operating temperature -40°C ≤ TA ≤ +85°C for Industrial -40°C ≤ TA ≤ +125°C for Extended | | | | |
|--------------------|-----------------------|--|---|--------------------|-----|-------|---|
| Param No. | Symbol | Characteristic ⁽¹⁾ | Min | Typ ⁽²⁾ | Max | Units | Conditions |
| SP70 | TscP | Maximum SCKx Input Frequency | — | — | 15 | MHz | See Note 3 |
| SP72 | TscF | SCKx Input Fall Time | — | — | — | ns | See Parameter DO32 and Note 4 |
| SP73 | TscR | SCKx Input Rise Time | — | — | — | ns | See Parameter DO31 and Note 4 |
| SP30 | TdoF | SDOx Data Output Fall Time | — | — | — | ns | See Parameter DO32 and Note 4 |
| SP31 | TdoR | SDOx Data Output Rise Time | — | — | — | ns | See Parameter DO31 and Note 4 |
| SP35 | Tsch2doV, TscL2doV | SDOx Data Output Valid after SCKx Edge | — | 6 | 20 | ns | |
| SP36 | TdoV2scH, TdoV2scL | SDOx Data Output Setup to First SCKx Edge | 30 | — | — | ns | |
| SP40 | TdiV2scH, TdiV2scL | Setup Time of SDIx Data Input to SCKx Edge | 30 | — | — | ns | |
| SP41 | Tsch2diL, TscL2diL | Hold Time of SDIx Data Input to SCKx Edge | 30 | — | — | ns | |
| SP50 | TssL2scH, TssL2scL | $\overline{SSx} \downarrow$ to SCKx \uparrow or SCKx Input | 120 | — | — | ns | |
| SP51 | TssH2doZ | $\overline{SSx} \uparrow$ to SDOx Output High-Impedance | 10 | — | 50 | ns | See Note 4 |
| SP52 | Tsch2ssH TscL2ssH | \overline{SSx} after SCKx Edge | 1.5 TCY + 40 | — | — | ns | See Note 4 |

- Note 1:** These parameters are characterized, but are not tested in manufacturing.
Note 2: Data in “Typ” column is at 3.3V, +25°C unless otherwise stated.
Note 3: The minimum clock period for SCKx is 66.7 ns. Therefore, the SCKx clock, generated by the master, must not violate this specification.
Note 4: Assumes 50 pF load on all SPIx pins.

FIGURE 27-18: SPIx SLAVE MODE (FULL-DUPLEX, CKE = 0, CKP = 0, SMP = 0) TIMING CHARACTERISTICS



TABLE 27-37: SPIx SLAVE MODE (FULL-DUPLEX, CKE = 0, CKP = 0, SMP = 0) TIMING REQUIREMENTS

| AC CHARACTERISTICS | | | Standard Operating Conditions: 3.0V to 3.6V (unless otherwise stated) Operating temperature -40°C ≤ TA ≤ +85°C for Industrial -40°C ≤ TA ≤ +125°C for Extended | | | | |
|--------------------|-----------------------|--|---|--------------------|-----|-------|---|
| Param No. | Symbol | Characteristic ⁽¹⁾ | Min | Typ ⁽²⁾ | Max | Units | Conditions |
| SP70 | TscP | Maximum SCKx Input Frequency | — | — | 11 | MHz | See Note 3 |
| SP72 | TscF | SCKx Input Fall Time | — | — | — | ns | See Parameter DO32 and Note 4 |
| SP73 | TscR | SCKx Input Rise Time | — | — | — | ns | See Parameter DO31 and Note 4 |
| SP30 | TdoF | SDOx Data Output Fall Time | — | — | — | ns | See Parameter DO32 and Note 4 |
| SP31 | TdoR | SDOx Data Output Rise Time | — | — | — | ns | See Parameter DO31 and Note 4 |
| SP35 | Tsch2doV, TscL2doV | SDOx Data Output Valid after SCKx Edge | — | 6 | 20 | ns | |
| SP36 | TdoV2sch, TdoV2scL | SDOx Data Output Setup to First SCKx Edge | 30 | — | — | ns | |
| SP40 | TdiV2sch, TdiV2scL | Setup Time of SDIx Data Input to SCKx Edge | 30 | — | — | ns | |
| SP41 | Tsch2diL, TscL2diL | Hold Time of SDIx Data Input to SCKx Edge | 30 | — | — | ns | |
| SP50 | TssL2sch, TssL2scL | $\overline{SSx} \downarrow$ to SCKx \uparrow or SCKx Input | 120 | — | — | ns | |
| SP51 | TssH2doZ | $\overline{SSx} \uparrow$ to SDOx Output High-Impedance | 10 | — | 50 | ns | See Note 4 |
| SP52 | Tsch2ssH TscL2ssH | \overline{SSx} after SCKx Edge | 1.5 TCY + 40 | — | — | ns | See Note 4 |

- Note 1:** These parameters are characterized, but are not tested in manufacturing.
Note 2: Data in “Typ” column is at 3.3V, +25°C unless otherwise stated.
Note 3: The minimum clock period for SCKx is 91 ns. Therefore, the SCKx clock, generated by the master, must not violate this specification.
Note 4: Assumes 50 pF load on all SPIx pins.

FIGURE 27-19: I2Cx BUS START/STOP BITS TIMING CHARACTERISTICS (MASTER MODE)



FIGURE 27-20: I2Cx BUS DATA TIMING CHARACTERISTICS (MASTER MODE)



TABLE 27-38: I2Cx BUS DATA TIMING REQUIREMENTS (MASTER MODE)

| AC CHARACTERISTICS | | | | Standard Operating Conditions: 3.0V to 3.6V (unless otherwise stated) Operating temperature -40°C ≤ TA ≤ +85°C for Industrial -40°C ≤ TA ≤ +125°C for Extended | | | |
|--------------------|---------|----------------------------|---------------------------|---|------|------------|---|
| Param No. | Symbol | Characteristic | | Min ⁽¹⁾ | Max | Units | Conditions |
| IM10 | TLO:SCL | Clock Low Time | 100 kHz mode | T _{CY} /2 (BRG + 1) | — | μs | |
| | | | 400 kHz mode | T _{CY} /2 (BRG + 1) | — | μs | |
| | | | 1 MHz mode ⁽²⁾ | T _{CY} /2 (BRG + 1) | — | μs | |
| IM11 | THI:SCL | Clock High Time | 100 kHz mode | T _{CY} /2 (BRG + 1) | — | μs | |
| | | | 400 kHz mode | T _{CY} /2 (BRG + 1) | — | μs | |
| | | | 1 MHz mode ⁽²⁾ | T _{CY} /2 (BRG + 1) | — | μs | |
| IM20 | TF:SCL | SDAx and SCLx Fall Time | 100 kHz mode | — | 300 | ns | Cb is specified to be from 10 to 400 pF |
| | | | 400 kHz mode | 20 + 0.1 Cb | 300 | ns | |
| | | | 1 MHz mode ⁽²⁾ | — | 100 | ns | |
| IM21 | TR:SCL | SDAx and SCLx Rise Time | 100 kHz mode | — | 1000 | ns | Cb is specified to be from 10 to 400 pF |
| | | | 400 kHz mode | 20 + 0.1 Cb | 300 | ns | |
| | | | 1 MHz mode ⁽²⁾ | — | 300 | ns | |
| IM25 | TSU:DAT | Data Input Setup Time | 100 kHz mode | 250 | — | ns | |
| | | | 400 kHz mode | 100 | — | ns | |
| | | | 1 MHz mode ⁽²⁾ | 40 | — | ns | |
| IM26 | THD:DAT | Data Input Hold Time | 100 kHz mode | 0 | — | μs | |
| | | | 400 kHz mode | 0 | 0.9 | μs | |
| | | | 1 MHz mode ⁽²⁾ | 0.2 | — | μs | |
| IM30 | TSU:STA | Start Condition Setup Time | 100 kHz mode | T _{CY} /2 (BRG + 1) | — | μs | Only relevant for Repeated Start condition |
| | | | 400 kHz mode | T _{CY} /2 (BRG + 1) | — | μs | |
| | | | 1 MHz mode ⁽²⁾ | T _{CY} /2 (BRG + 1) | — | μs | |
| IM31 | THD:STA | Start Condition Hold Time | 100 kHz mode | T _{CY} /2 (BRG + 1) | — | μs | After this period, the first clock pulse is generated |
| | | | 400 kHz mode | T _{CY} /2 (BRG + 1) | — | μs | |
| | | | 1 MHz mode ⁽²⁾ | T _{CY} /2 (BRG + 1) | — | μs | |
| IM33 | TSU:STO | Stop Condition Setup Time | 100 kHz mode | T _{CY} /2 (BRG + 1) | — | μs | |
| | | | 400 kHz mode | T _{CY} /2 (BRG + 1) | — | μs | |
| | | | 1 MHz mode ⁽²⁾ | T _{CY} /2 (BRG + 1) | — | μs | |
| IM34 | THD:STO | Stop Condition Hold Time | 100 kHz mode | T _{CY} /2 (BRG + 1) | — | ns | |
| | | | 400 kHz mode | T _{CY} /2 (BRG + 1) | — | ns | |
| | | | 1 MHz mode ⁽²⁾ | T _{CY} /2 (BRG + 1) | — | ns | |
| IM40 | TAA:SCL | Output Valid from Clock | 100 kHz mode | — | 3500 | ns | |
| | | | 400 kHz mode | — | 1000 | ns | |
| | | | 1 MHz mode ⁽²⁾ | — | 400 | ns | |
| IM45 | TBF:SDA | Bus Free Time | 100 kHz mode | 4.7 | — | μs | Time the bus must be free before a new transmission can start |
| | | | 400 kHz mode | 1.3 | — | μs | |
| | | | 1 MHz mode ⁽²⁾ | 0.5 | — | μs | |
| IM50 | CB | Bus Capacitive Loading | — | 400 | pF | | |
| IM51 | TPGD | Pulse Gobbler Delay | 65 | 390 | ns | See Note 3 | |

Note 1: BRG is the value of the I²C™ Baud Rate Generator. Refer to Section 19. “Inter-Integrated Circuit (I²C™)” (DS70195) in the “dsPIC33F/PIC24H Family Reference Manual”.

2: Maximum pin capacitance = 10 pF for all I2Cx pins (for 1 MHz mode only).

3: Typical value for this parameter is 130 ns.

FIGURE 27-21: I2Cx BUS START/STOP BITS TIMING CHARACTERISTICS (SLAVE MODE)



FIGURE 27-22: I2Cx BUS DATA TIMING CHARACTERISTICS (SLAVE MODE)



dsPIC33FJ32GS406/606/608/610 and dsPIC33FJ64GS406/606/608/610

TABLE 27-39: I2Cx BUS DATA TIMING REQUIREMENTS (SLAVE MODE)

| AC CHARACTERISTICS | | | | Standard Operating Conditions: 3.0V to 3.6V (unless otherwise stated) Operating temperature -40°C ≤ TA ≤ +85°C for Industrial -40°C ≤ TA ≤ +125°C for Extended | | | |
|--------------------|---------|----------------------------|---------------------------|---|------|-------|---|
| Param. | Symbol | Characteristic | | Min | Max | Units | Conditions |
| IS10 | TLO:SCL | Clock Low Time | 100 kHz mode | 4.7 | — | μs | Device must operate at a minimum of 1.5 MHz |
| | | | 400 kHz mode | 1.3 | — | μs | Device must operate at a minimum of 10 MHz |
| | | | 1 MHz mode ⁽¹⁾ | 0.5 | — | μs | |
| IS11 | THI:SCL | Clock High Time | 100 kHz mode | 4.0 | — | μs | Device must operate at a minimum of 1.5 MHz |
| | | | 400 kHz mode | 0.6 | — | μs | Device must operate at a minimum of 10 MHz |
| | | | 1 MHz mode ⁽¹⁾ | 0.5 | — | μs | |
| IS20 | TF:SCL | SDAx and SCLx Fall Time | 100 kHz mode | — | 300 | ns | Cb is specified to be from 10 to 400 pF |
| | | | 400 kHz mode | 20 + 0.1 Cb | 300 | ns | |
| | | | 1 MHz mode ⁽¹⁾ | — | 100 | ns | |
| IS21 | Tr:SCL | SDAx and SCLx Rise Time | 100 kHz mode | — | 1000 | ns | Cb is specified to be from 10 to 400 pF |
| | | | 400 kHz mode | 20 + 0.1 Cb | 300 | ns | |
| | | | 1 MHz mode ⁽¹⁾ | — | 300 | ns | |
| IS25 | TSU:DAT | Data Input Setup Time | 100 kHz mode | 250 | — | ns | |
| | | | 400 kHz mode | 100 | — | ns | |
| | | | 1 MHz mode ⁽¹⁾ | 100 | — | ns | |
| IS26 | THD:DAT | Data Input Hold Time | 100 kHz mode | 0 | — | μs | |
| | | | 400 kHz mode | 0 | 0.9 | μs | |
| | | | 1 MHz mode ⁽¹⁾ | 0 | 0.3 | μs | |
| IS30 | TSU:STA | Start Condition Setup Time | 100 kHz mode | 4.7 | — | μs | Only relevant for Repeated Start condition |
| | | | 400 kHz mode | 0.6 | — | μs | |
| | | | 1 MHz mode ⁽¹⁾ | 0.25 | — | μs | |
| IS31 | THD:STA | Start Condition Hold Time | 100 kHz mode | 4.0 | — | μs | After this period, the first clock pulse is generated |
| | | | 400 kHz mode | 0.6 | — | μs | |
| | | | 1 MHz mode ⁽¹⁾ | 0.25 | — | μs | |
| IS33 | TSU:STO | Stop Condition Setup Time | 100 kHz mode | 4.7 | — | μs | |
| | | | 400 kHz mode | 0.6 | — | μs | |
| | | | 1 MHz mode ⁽¹⁾ | 0.6 | — | μs | |
| IS34 | THD:STO | Stop Condition Hold Time | 100 kHz mode | 4000 | — | ns | |
| | | | 400 kHz mode | 600 | — | ns | |
| | | | 1 MHz mode ⁽¹⁾ | 250 | — | ns | |
| IS40 | TAA:SCL | Output Valid From Clock | 100 kHz mode | 0 | 3500 | ns | |
| | | | 400 kHz mode | 0 | 1000 | ns | |
| | | | 1 MHz mode ⁽¹⁾ | 0 | 350 | ns | |
| IS45 | TBF:SDA | Bus Free Time | 100 kHz mode | 4.7 | — | μs | Time the bus must be free before a new transmission can start |
| | | | 400 kHz mode | 1.3 | — | μs | |
| | | | 1 MHz mode ⁽¹⁾ | 0.5 | — | μs | |
| IS50 | Cb | Bus Capacitive Loading | | — | 400 | pF | |

Note 1: Maximum pin capacitance = 10 pF for all I2Cx pins (for 1 MHz mode only).

dsPIC33FJ32GS406/606/608/610 and dsPIC33FJ64GS406/606/608/610

TABLE 27-40: 10-BIT, HIGH-SPEED ADC MODULE SPECIFICATIONS

| AC CHARACTERISTICS | | | Standard Operating Conditions: 3.0V and 3.6V ⁽²⁾ (unless otherwise stated) Operating temperature -40°C ≤ TA ≤ +85°C for Industrial -40°C ≤ TA ≤ +125°C for Extended | | | | |
|----------------------------|------------------|--|---|-------|----------------------------|-------|---|
| Param No. | Symbol | Characteristic | Min | Typ | Max | Units | Conditions |
| Device Supply | | | | | | | |
| AD01 | AVDD | Module VDD Supply | Greater of VDD - 0.3 or 3.0 | — | Lesser of VDD + 0.3 or 3.6 | V | |
| AD02 | AVSS | Module VSS Supply | VSS - 0.3 | — | VSS + 0.3 | V | |
| Analog Input | | | | | | | |
| AD10 | VINH-VINL | Full-Scale Input Span | VSS | — | VDD | V | |
| AD11 | VIN | Absolute Input Voltage | AVSS | — | AVDD | V | |
| AD12 | IAD | Operating Current | — | 8 | — | mA | |
| AD13 | — | Leakage Current | — | ±0.6 | — | μA | VINL = AVSS = 0V, AVDD = 3.3V Source Impedance = 100Ω |
| AD17 | RIN | Recommended Impedance of Analog Voltage Source | — | — | 100 | Ω | |
| DC Accuracy | | | | | | | |
| AD20 | Nr | Resolution | 10 data bits | | | bits | |
| AD21A | INL | Integral Nonlinearity | > -2 | ±0.5 | < 2 | LSb | VINL = AVSS = 0V, AVDD = 3.3V |
| AD22A | DNL | Differential Nonlinearity | > -1 | ±0.5 | < 1 | LSb | VINL = AVSS = 0V, AVDD = 3.3V |
| AD23A | GERR | Gain Error | > -5 | ±2.0 | < 5 | LSb | VINL = AVSS = 0V, AVDD = 3.3V |
| AD24A | E _{OFF} | Offset Error | > -3 | ±0.75 | < 3 | LSb | VINL = AVSS = VSS = 0V, AVDD = VDD = 3.3V |
| AD25 | — | Monotonicity ⁽¹⁾ | — | — | — | — | Guaranteed |
| Dynamic Performance | | | | | | | |
| AD30 | THD | Total Harmonic Distortion | — | -73 | — | dB | |
| AD31 | SINAD | Signal to Noise and Distortion | — | 58 | — | dB | |
| AD32 | SFDR | Spurious Free Dynamic Range | — | -73 | — | dB | |
| AD33 | FNYQ | Input Signal Bandwidth | — | — | 1 | MHz | |
| AD34 | ENOB | Effective Number of Bits | — | 9.4 | — | bits | |

Note 1: The Analog-to-Digital conversion result never decreases with an increase in the input voltage and has no missing codes.

2: Overall functional device operation at $V_{BOR} < V_{DD} < V_{DDMIN}$ is ensured but not characterized. All device analog modules, such as the ADC, etc., will function but with degraded performance below V_{DDMIN} .

TABLE 27-41: 10-BIT, HIGH-SPEED ADC MODULE TIMING REQUIREMENTS

| AC CHARACTERISTICS | | | Standard Operating Conditions: 3.0V to 3.6V ⁽²⁾ (unless otherwise stated) Operating temperature -40°C ≤ TA ≤ +85°C for Industrial -40°C ≤ TA ≤ +125°C for Extended | | | | |
|--------------------------|--------|--|--|--------------------|-----|-------|------------|
| Param No. | Symbol | Characteristic | Min | Typ ⁽¹⁾ | Max | Units | Conditions |
| Clock Parameters | | | | | | | |
| AD50b | TAD | ADC Clock Period | 35.8 | — | — | ns | |
| Conversion Rate | | | | | | | |
| AD55b | tCONV | Conversion Time | — | 14 TAD | — | — | |
| AD56b | FCNV | Throughput Rate | | | | | |
| | | Devices with Single SAR | — | — | 2.0 | Msp/s | |
| | | Devices with Dual SARs | — | — | 4.0 | Msp/s | |
| Timing Parameters | | | | | | | |
| AD63b | tDPU | Time to Stabilize Analog Stage from ADC Off to ADC On ⁽¹⁾ | 1.0 | — | 10 | μs | |

Note 1: These parameters are characterized but not tested in manufacturing.

2: Overall functional device operation at VBOR < VDD < VDDMIN is guaranteed but not characterized. All device analog modules such as the ADC, etc., will function but with degraded performance below VDDMIN.

FIGURE 27-23: ANALOG-TO-DIGITAL CONVERSION TIMING PER INPUT

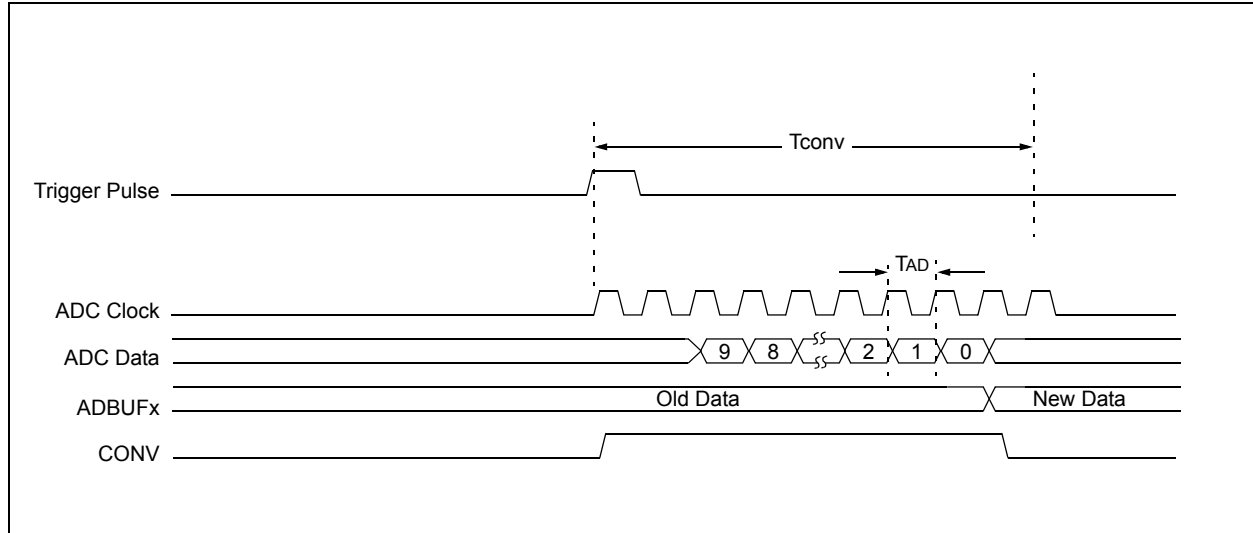

dsPIC33FJ32GS406/606/608/610 and dsPIC33FJ64GS406/606/608/610

TABLE 27-42: COMPARATOR MODULE SPECIFICATIONS

| AC and DC CHARACTERISTICS | | | Standard Operating Conditions (unless otherwise stated) Operating temperature: $-40^{\circ}\text{C} \leq T_A \leq +85^{\circ}\text{C}$ for Industrial $-40^{\circ}\text{C} \leq T_A \leq +125^{\circ}\text{C}$ for Extended | | | | |
|---------------------------|--------|--|---|---------|-----------------|-------|--|
| Param. No. | Symbol | Characteristic | Min | Typ | Max | Units | Comments |
| CM10 | VIOFF | Input Offset Voltage | | ± 5 | ± 15 | mV | |
| CM11 | VICM | Input Common-Mode Voltage Range ⁽¹⁾ | 0 | — | $AV_{DD} - 1.5$ | V | |
| CM12 | VGAIN | Open-Loop Gain ⁽¹⁾ | 90 | — | — | db | |
| CM13 | CMRR | Common-Mode Rejection Ratio ⁽¹⁾ | 70 | — | — | db | |
| CM14 | TRESP | Large Signal Response | | 20 | 30 | ns | V+ input step of 100 mv while V- input held at $AV_{DD}/2$. Delay measured from analog input pin to PWM output pin. |

Note 1: Parameters are for design guidance only and are not tested in manufacturing.

TABLE 27-43: DAC MODULE SPECIFICATIONS

| AC and DC CHARACTERISTICS | | | Standard Operating Conditions (unless otherwise stated) Operating temperature: $-40^{\circ}\text{C} \leq T_A \leq +85^{\circ}\text{C}$ for Industrial $-40^{\circ}\text{C} \leq T_A \leq +125^{\circ}\text{C}$ for Extended | | | | |
|---------------------------|--------|---|---|-----------|-----------------|-------|---|
| Param. No. | Symbol | Characteristic | Min | Typ | Max | Units | Comments |
| DA01 | EXTREF | External Reference Voltage ⁽¹⁾ | 0 | — | $AV_{DD} - 1.6$ | V | |
| DA08 | INTREF | Internal Reference Voltage ⁽¹⁾ | 1.25 | 1.32 | 1.41 | V | |
| DA02 | CVRES | Resolution | 10 data bits | | | bits | |
| DA03 | INL | Integral Nonlinearity Error | — | ± 1.0 | — | — | $AV_{DD} = 3.3\text{V}$, $DAC_{REF} = (AV_{DD}/2)\text{V}$ |
| DA04 | DNL | Differential Nonlinearity Error | — | ± 0.8 | — | LSB | |
| DA05 | E0FF | Offset Error | — | ± 2.0 | — | LSB | |
| DA06 | EG | Gain Error | — | ± 2.0 | — | LSB | |
| DA07 | TSET | Settling Time ⁽¹⁾ | — | — | 650 | nsec | Measured when range = 1 (high range) and $CM_{REF}<9:0>$ transitions from 0x1FF to 0x300. |

Note 1: Parameters are for design guidance only and are not tested in manufacturing.

TABLE 27-44: DAC OUTPUT BUFFER SPECIFICATIONS

| DC CHARACTERISTICS | | | Standard Operating Conditions (unless otherwise stated) Operating temperature: $-40^{\circ}\text{C} \leq T_A \leq +85^{\circ}\text{C}$ for Industrial $-40^{\circ}\text{C} \leq T_A \leq +125^{\circ}\text{C}$ for Extended | | | | |
|--------------------|---------|---|---|-----|--------------------------------|---------------|--|
| Param. No. | Symbol | Characteristic | Min | Typ | Max | Units | Comments |
| DA10 | RLOAD | Resistive Output Load Impedance | 3K | — | — | Ω | |
| DA11 | CLOAD | Output Load Capacitance | — | 20 | 35 | μF | |
| DA12 | IOUT | Output Current Drive Strength | 200 | 300 | 400 | μA | Sink and source |
| DA13 | VRANGE | Full Output Drive Strength Voltage Range | $\text{AVSS} + 250 \text{ mV}$ | — | $\text{AVDD} - 900 \text{ mV}$ | V | |
| DA14 | VLRANGE | Output Drive Voltage Range at Reduced Current Drive of $50 \mu\text{A}$ | $\text{AVSS} + 50 \text{ mV}$ | — | $\text{AVDD} - 500 \text{ mV}$ | V | |
| DA15 | IDD | Current Consumed when Module is Enabled, High-Power Mode | — | — | $1.3 \times \text{IOUT}$ | μA | Module will always consume this current even if no load is connected to the output |
| DA16 | ROUTON | Output Impedance when Module is Enabled | — | 500 | — | Ω | |

FIGURE 27-24: QEA/QEB INPUT CHARACTERISTICS



dsPIC33FJ32GS406/606/608/610 and dsPIC33FJ64GS406/606/608/610

TABLE 27-45: QUADRATURE DECODER TIMING REQUIREMENTS

| AC CHARACTERISTICS | | Standard Operating Conditions: 3.0V to 3.6V (unless otherwise stated) Operating temperature $-40^{\circ}\text{C} \leq T_A \leq +85^{\circ}\text{C}$ for Industrial $-40^{\circ}\text{C} \leq T_A \leq +125^{\circ}\text{C}$ for Extended | | | | |
|--------------------|--------|---|--------------------|-----|-------|--|
| Param No. | Symbol | Characteristic ⁽¹⁾ | Typ ⁽²⁾ | Max | Units | Conditions |
| TQ30 | TqUL | Quadrature Input Low Time | 6 TcY | — | ns | |
| TQ31 | TqUH | Quadrature Input High Time | 6 TcY | — | ns | |
| TQ35 | TqUIN | Quadrature Input Period | 12 TcY | — | ns | |
| TQ36 | TqUP | Quadrature Phase Period | 3 TcY | — | ns | |
| TQ40 | TqUFL | Filter Time to Recognize Low, with Digital Filter | $3 * N * TcY$ | — | ns | N = 1, 2, 4, 16, 32, 64, 128 and 256 (Note 3) |
| TQ41 | TqUFH | Filter Time to Recognize High, with Digital Filter | $3 * N * TcY$ | — | ns | N = 1, 2, 4, 16, 32, 64, 128 and 256 (Note 3) |

Note 1: These parameters are characterized but not tested in manufacturing.

2: Data in “Typ” column is at 3.3V, +25°C unless otherwise stated.

3: N = Index Channel Digital Filter Clock Divide Select bits. Refer to **Section 15. “Quadrature Encoder Interface (QEI)”** (DS70208) in the “dsPIC33F/PIC24H Family Reference Manual”.

FIGURE 27-25: QEI MODULE INDEX PULSE TIMING CHARACTERISTICS

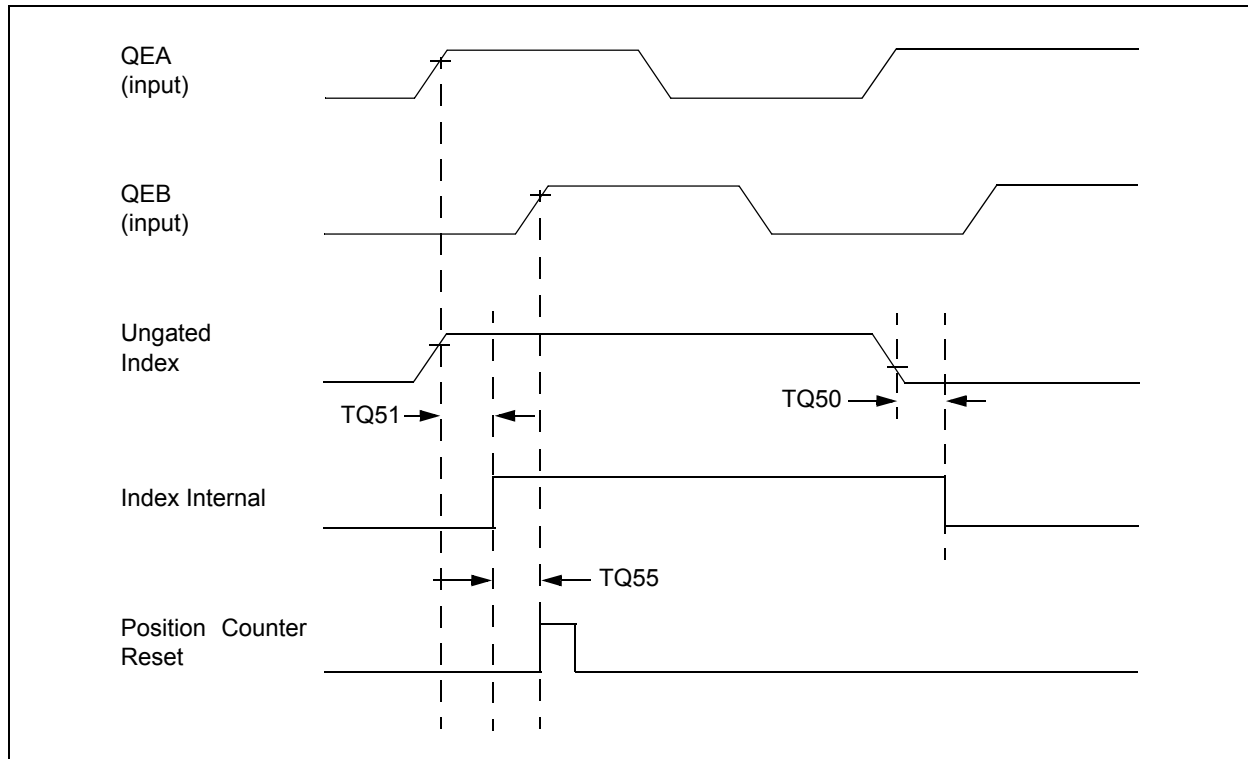

TABLE 27-46: QEI INDEX PULSE TIMING REQUIREMENTS

| AC CHARACTERISTICS | | Standard Operating Conditions: 3.0V to 3.6V (unless otherwise stated) Operating temperature $-40^{\circ}\text{C} \leq T_A \leq +85^{\circ}\text{C}$ for Industrial $-40^{\circ}\text{C} \leq T_A \leq +125^{\circ}\text{C}$ for Extended | | | | |
|--------------------|--------|---|------------------|-----|-------|---|
| Param No. | Symbol | Characteristic ⁽¹⁾ | Min | Max | Units | Conditions |
| TQ50 | TqIL | Filter Time to Recognize Low, with Digital Filter | $3 * N * T_{CY}$ | — | ns | N = 1, 2, 4, 16, 32, 64, 128 and 256 (Note 2) |
| TQ51 | TqiH | Filter Time to Recognize High, with Digital Filter | $3 * N * T_{CY}$ | — | ns | N = 1, 2, 4, 16, 32, 64, 128 and 256 (Note 2) |
| TQ55 | Tqidxr | Index Pulse Recognized to Position Counter Reset (ungated index) | $3 T_{CY}$ | — | ns | — |

- Note 1:** These parameters are characterized but not tested in manufacturing.
- Note 2:** Alignment of index pulses to QEA and QEB is shown for position counter Reset timing only. Shown for forward direction only (QEA leads QEB). Same timing applies for reverse direction (QEA lags QEB) but index pulse recognition occurs on the falling edge.

FIGURE 27-26: TIMERQ (QEI MODULE) EXTERNAL CLOCK TIMING CHARACTERISTICS



TABLE 27-47: QEI MODULE EXTERNAL CLOCK TIMING REQUIREMENTS

| AC CHARACTERISTICS | | Standard Operating Conditions: 3.0V to 3.6V (unless otherwise stated) Operating temperature $-40^{\circ}\text{C} \leq T_A \leq +85^{\circ}\text{C}$ for Industrial $-40^{\circ}\text{C} \leq T_A \leq +125^{\circ}\text{C}$ for Extended | | | | | | |
|--------------------|-----------|---|-----------------------------|-------------------|-----|--------------|-------|-------------------------------|
| Param No. | Symbol | Characteristic ⁽¹⁾ | | Min | Typ | Max | Units | Conditions |
| TQ10 | TtQH | TQCK High Time | Synchronous, with prescaler | $T_{CY} + 20$ | — | — | ns | Must also meet Parameter TQ15 |
| TQ11 | TtQL | TQCK Low Time | Synchronous, with prescaler | $T_{CY} + 20$ | — | — | ns | Must also meet Parameter TQ15 |
| TQ15 | TtQP | TQCP Input Period | Synchronous, with prescaler | $2 * T_{CY} + 40$ | — | — | ns | |
| TQ20 | TCKEXTMRL | Delay from External TxCK Clock Edge to Timer Increment | | $0.5 T_{CY}$ | — | $1.5 T_{CY}$ | — | |

- Note 1:** These parameters are characterized but not tested in manufacturing.

FIGURE 27-27: ECAN™ MODULE I/O TIMING CHARACTERISTICS

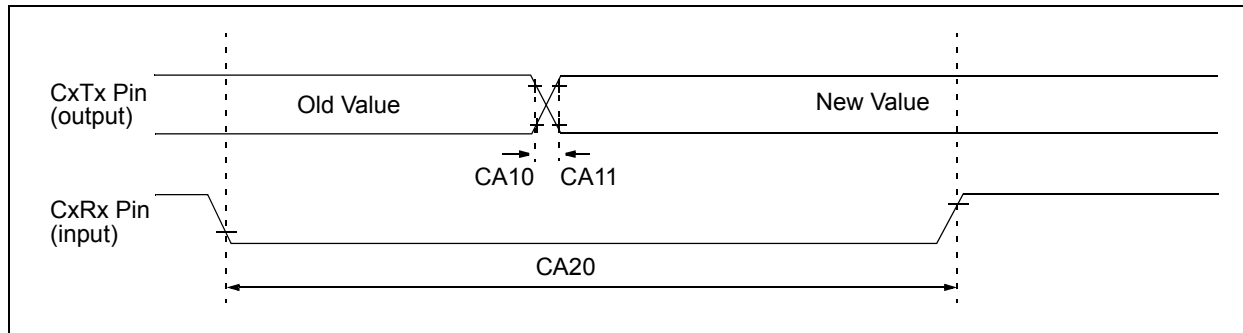

TABLE 27-48: ECAN™ MODULE I/O TIMING REQUIREMENTS

| AC CHARACTERISTICS | | | Standard Operating Conditions: 3.0V to 3.6V (unless otherwise stated) Operating temperature -40°C ≤ TA ≤ +85°C for Industrial -40°C ≤ TA ≤ +125°C for Extended | | | | |
|--------------------|--------|---|---|-----|-----|-------|------------------------------------|
| Param No. | Symbol | Characteristic ⁽¹⁾ | Min | Typ | Max | Units | Conditions |
| CA10 | TioF | Port Output Fall Time | — | — | — | ns | See Parameter DO32 |
| CA11 | TioR | Port Output Rise Time | — | — | — | ns | See Parameter DO31 |
| CA20 | Tcwf | Pulse Width to Trigger CAN Wake-up Filter | 120 | — | — | ns | |

Note 1: These parameters are characterized but not tested in manufacturing.

TABLE 27-49: DMA READ/WRITE TIMING REQUIREMENTS

| AC CHARACTERISTICS | | Standard Operating Conditions: 3.0V to 3.6V (unless otherwise stated) Operating temperature -40°C ≤ TA ≤ +85°C for Industrial -40°C ≤ TA ≤ +125°C for Extended | | | | |
|--------------------|---------------------------|---|-----|-------------------|-------|------------|
| Param No. | Characteristic | Min. | Typ | Max. | Units | Conditions |
| DM1 | DMA Read/Write Cycle Time | — | — | 1 T _{CY} | ns | |

28.0 50 MIPS ELECTRICAL CHARACTERISTICS

This section provides an overview of dsPIC33FJ32GS406/606/608/610 and dsPIC33FJ64GS406/606/608/610 electrical characteristics for devices operating at 50 MIPS.

Specifications are identical to those shown in [Section 27.0 “Electrical Characteristics”](#), with the exception of the parameters listed in this section.

Absolute maximum ratings for the dsPIC33FJ32GS406/606/608/610 and dsPIC33FJ64GS406/606/608/610 50 MIPS devices are listed below. Exposure to these maximum rating conditions for extended periods can affect device reliability. Functional operation of the device at these or any other conditions above the parameters indicated in the operation listings of this specification is not implied.

Absolute Maximum Ratings⁽¹⁾

| | |
|--|-----------------------|
| Ambient temperature under bias | -40°C to +85°C |
| Storage temperature | -65°C to +150°C |
| Voltage on VDD with respect to VSS | -0.3V to +4.0V |
| Voltage on any pin that is not 5V tolerant, with respect to VSS ⁽²⁾ | -0.3V to (VDD + 0.3V) |
| Voltage on any 5V tolerant pin with respect to VSS, when VDD ≥ 3.0V ⁽²⁾ | -0.3V to +5.6V |
| Voltage on any 5V tolerant pin with respect to VSS, when VDD < 3.0V ⁽²⁾ | -0.3V to (VDD + 0.3V) |
| Maximum current out of VSS pin | 300 mA |
| Maximum current into VDD pin ⁽²⁾ | 250 mA |
| Maximum current sourced/sunk by any 4x I/O pin | 15 mA |
| Maximum current sourced/sunk by any 8x I/O pin | 25 mA |
| Maximum current sourced/sunk by any 16x I/O pin | 45 mA |
| Maximum current sunk by all ports | 200 mA |
| Maximum current sourced by all ports ⁽²⁾ | 200mA |

Note 1: Stresses above those listed under “Absolute Maximum Ratings” may cause permanent damage to the device. This is a stress rating only, and functional operation of the device at those or any other conditions above those indicated in the operation listings of this specification is not implied. Exposure to maximum rating conditions for extended periods may affect device reliability.

2: See the “[Pin Diagrams](#)” section for 5V tolerant pins.

dsPIC33FJ32GS406/606/608/610 and dsPIC33FJ64GS406/606/608/610

28.1 DC Characteristics

TABLE 28-1: OPERATING MIPS vs. VOLTAGE

| Characteristic | VDD Range (in Volts) | Temp Range (in °C) | Max MIPS |
|----------------|-------------------------|-----------------------|--|
| | | | dsPIC33FJ32GS406/606/608/610 and dsPIC33FJ64GS406/606/608/610 |
| — | 3.0-3.6V ⁽¹⁾ | -40°C to +85°C | 50 |

Note 1: Overall functional device operation at $V_{BORMIN} < V_{DD} < V_{DDMIN}$ is tested but not characterized. All device analog modules, such as the ADC, etc., will function but with degraded performance below V_{DDMIN} . See Parameter **BO10** in [Table 27-11](#) for the BOR values.

TABLE 28-2: DC CHARACTERISTICS: OPERATING CURRENT (IDD)

| DC CHARACTERISTICS | | | Standard Operating Conditions: 3.0V to 3.6V (unless otherwise stated) Operating temperature $-40^{\circ}\text{C} \leq T_A \leq +85^{\circ}\text{C}$ for Industrial | | |
|--|---------|-----|---|------------|-----------------|
| Parameter No. | Typical | Max | Units | Conditions | |
| Operating Current (IDD)⁽¹⁾ | | | | | |
| MDC29d | 85 | 100 | mA | -40°C | 3.3V 50 MIPS |
| MDC29a | 85 | 100 | mA | +25°C | |
| MDC29b | 85 | 100 | mA | +85°C | |

Note 1: I_{DD} is primarily a function of the operating voltage and frequency. Other factors, such as I/O pin loading and switching rate, oscillator type, internal code execution pattern and temperature, also have an impact on the current consumption. The test conditions for all I_{DD} measurements are as follows:

- Oscillator is configured in EC mode with PLL, OSC1 is driven with external square wave from rail-to-rail (EC clock overshoot/undershoot < 250 mV required)
- CLKO is configured as an I/O input pin in the Configuration Word
- All I/O pins are configured as inputs and pulled to V_{SS}
- $\overline{\text{MCLR}} = V_{DD}$, WDT and FSCM are disabled
- CPU, SRAM, program memory and data memory are operational
- No peripheral modules are operating; however, every peripheral is being clocked (all PMDx bits are zeroed)
- CPU executing `while(1)` statement
- JTAG is disabled

TABLE 28-3: DC CHARACTERISTICS: IDLE CURRENT (I_{IDLE})

| DC CHARACTERISTICS | | | Standard Operating Conditions: 3.0V to 3.6V (unless otherwise stated) Operating temperature $-40^{\circ}\text{C} \leq T_A \leq +85^{\circ}\text{C}$ for Industrial | | | |
|--|---------|-----|--|------------|------|---------|
| Parameter No. | Typical | Max | Units | Conditions | | |
| Idle Current (I_{IDLE}): Core Off Clock On Base Current⁽¹⁾ | | | | | | |
| MDC45d | 40 | 50 | mA | -40°C | 3.3V | 50 MIPS |
| MDC45a | 40 | 50 | mA | +25°C | | |
| MDC45b | 40 | 50 | mA | +85°C | | |

Note 1: Base Idle current (I_{IDLE}) is measured as follows:

- CPU core is off, oscillator is configured in EC mode and external clock is active, OSC1 is driven with external square wave from rail-to-rail (EC clock overshoot/undershoot < 250 mV required)
- CLKO is configured as an I/O input pin in the Configuration Word
- All I/O pins are configured as inputs and pulled to V_{SS}
- MCLR = V_{DD}, WDT and FSCM are disabled
- No peripheral modules are operating; however, every peripheral is being clocked (all PMD_x bits are '0's)
- JTAG is disabled

dsPIC33FJ32GS406/606/608/610 and dsPIC33FJ64GS406/606/608/610

TABLE 28-4: DC CHARACTERISTICS: DOZE CURRENT (IDOZE)

| DC CHARACTERISTICS | | | Standard Operating Conditions: 3.0V to 3.6V (unless otherwise stated) Operating temperature $-40^{\circ}\text{C} \leq T_A \leq +85^{\circ}\text{C}$ for Industrial | | | | |
|---|---------|-----|--|-------|------------|------|---------|
| Parameter No. | Typical | Max | Doze Ratio | Units | Conditions | | |
| Doze Current (IDOZE)⁽¹⁾ | | | | | | | |
| MDC74a | 49 | 70 | 1:2 | mA | -40°C | 3.3V | 50 MIPS |
| MDC74f | 43 | 70 | 1:64 | mA | | | |
| MDC74g | 43 | 70 | 1:128 | mA | | | |
| MDC75a | 47 | 70 | 1:2 | mA | +25°C | 3.3V | 50 MIPS |
| MDC75f | 41 | 70 | 1:64 | mA | | | |
| MDC75g | 41 | 70 | 1:128 | mA | | | |
| MDC76a | 46 | 70 | 1:2 | mA | +85°C | 3.3V | 50 MIPS |
| MDC76f | 40 | 70 | 1:64 | mA | | | |
| MDC76g | 40 | 70 | 1:128 | mA | | | |

Note 1: IDOZE is primarily a function of the operating voltage and frequency. Other factors, such as I/O pin loading and switching rate, oscillator type, internal code execution pattern and temperature, also have an impact on the current consumption. The test conditions for all IDOZE measurements are as follows:

- Oscillator is configured in EC mode and external clock is active, OSC1 is driven with external square wave from rail-to-rail (EC clock overshoot/undershoot < 250 mV required)
- CLKO is configured as an I/O input pin in the Configuration Word
- All I/O pins are configured as inputs and pulled to Vss
- MCLR = VDD, WDT and FSCM are disabled
- CPU, SRAM, program memory and data memory are operational
- No peripheral modules are operating; however, every peripheral is being clocked (all PMDx bits are '0's)
- CPU executing `while(1)` statement
- JTAG is disabled

28.2 AC Characteristics and Timing Parameters

This section defines the dsPIC33FJ32GS406/606/608/610 and dsPIC33FJ64GS406/606/608/610 AC characteristics and timing parameters for 50 MIPS devices.

TABLE 28-5: EXTERNAL CLOCK TIMING REQUIREMENTS

| AC CHARACTERISTICS | | | Standard Operating Conditions: 3.0V to 3.6V (unless otherwise stated) Operating temperature $-40^{\circ}\text{C} \leq T_A \leq +85^{\circ}\text{C}$ for Industrial | | | | |
|--------------------|---------------|--|--|--------------------|------------------------|-------------------|---|
| Param No. | Symb | Characteristic | Min | Typ ⁽¹⁾ | Max | Units | Conditions |
| MOS10 | FIN | External CLKI Frequency (External clocks allowed only in EC and ECPLL modes) | DC | — | 50 | MHz | EC |
| | | Oscillator Crystal Frequency | 3.5 — 10 | — — — | 10 33 50 | MHz kHz MHz | XT SOSC HS |
| MOS20 | Tosc | $T_{osc} = 1/F_{osc}$ | 10 | — | DC | ns | |
| MOS25 | Tcy | Instruction Cycle Time ⁽²⁾ | 20 | — | DC | ns | |
| MOS30 | TosL, TosH | External Clock in (OSC1) High or Low Time | $0.375 \times T_{osc}$ | — | $0.625 \times T_{osc}$ | ns | EC |
| MOS31 | TosR, TosF | External Clock in (OSC1) Rise or Fall Time | — | — | 20 | ns | EC |
| MOS40 | TckR | CLKO Rise Time ⁽³⁾ | — | 5.2 | — | ns | |
| MOS41 | TckF | CLKO Fall Time ⁽³⁾ | — | 5.2 | — | ns | |
| MOS41 | GM | External Oscillator Transconductance | 14 | 16 | 18 | mA/V | $V_{DD} = 3.3V,$ $T_A = +25^{\circ}\text{C}$ |

Note 1: Data in “Typ” column is at 3.3V, +25°C unless otherwise stated.

2: Instruction cycle period (Tcy) equals two times the input oscillator time base period. All specified values are based on characterization data for that particular oscillator type under standard operating conditions with the device executing code. Exceeding these specified limits may result in an unstable oscillator operation and/or higher than expected current consumption. All devices are tested to operate at “min.” values with an external clock applied to the OSC1/CLKI pin. When an external clock input is used, the “max.” cycle time limit is “DC” (no clock) for all devices.

3: Measurements are taken in EC mode. The CLKO signal is measured on the OSC2 pin.

dsPIC33FJ32GS406/606/608/610 and dsPIC33FJ64GS406/606/608/610

TABLE 28-6: TIMER1 EXTERNAL CLOCK TIMING REQUIREMENTS⁽¹⁾

| AC CHARACTERISTICS | | | Standard Operating Conditions: 3.0V to 3.6V (unless otherwise stated) Operating temperature $-40^{\circ}\text{C} \leq T_A \leq +85^{\circ}\text{C}$ for Industrial | | | | | |
|--------------------|-----------|--|--|--|--------------------|-------|------------|---|
| Param No. | Symbol | Characteristic | Min | Typ | Max | Units | Conditions | |
| MTA10 | TTXH | T1CK High Time | Synchronous, no prescaler | $T_{CY} + 15$ | — | — | ns | Must also meet Parameter TA15, N = prescale value (1, 8, 64, 256) |
| | | | Synchronous, with prescaler | $(T_{CY} + 15)/N$ | — | — | ns | |
| | | | Asynchronous | 15 | — | — | ns | |
| MTA11 | TTXL | T1CK Low Time | Synchronous, no prescaler | $(T_{CY} + 15)$ | — | — | ns | Must also meet Parameter TA15, N = prescale value (1, 8, 64, 256) |
| | | | Synchronous, with prescaler | $(T_{CY} + 20)/N$ | — | — | ns | |
| | | | Asynchronous | 15 | — | — | ns | |
| MTA15 | TTXP | T1CK Input Period | Synchronous, no prescaler | $2 T_{CY} + 30$ | — | — | ns | N = prescale value (1, 8, 64, 256) |
| | | | Synchronous, with prescaler | Greater of: 40 ns or $(2 T_{CY} + 30)/N$ | — | — | — | |
| | | | Asynchronous | 30 | — | — | ns | |
| MOS60 | Ft1 | SOSCI/T1CK Oscillator Input Frequency Range (oscillator is enabled by setting bit, TCS (T1CON<1>)) | DC | — | 50 | kHz | | |
| MTA20 | TCKEXTMRL | Delay from External T1CK Clock Edge to Timer Increment | $0.75 T_{CY} + 30$ | — | $1.75 T_{CY} + 30$ | — | | |

Note 1: Timer1 is a Type A.

TABLE 28-7: TIMER2/4 EXTERNAL CLOCK TIMING REQUIREMENTS

| AC CHARACTERISTICS | | | | Standard Operating Conditions: 3.0V to 3.6V (unless otherwise stated) Operating temperature $-40^{\circ}\text{C} \leq T_A \leq +85^{\circ}\text{C}$ for Industrial | | | | |
|--------------------|-----------|--|------------------|--|-----|---------------|-------|--|
| Param No. | Symbol | Characteristic ⁽¹⁾ | | Min | Typ | Max | Units | Conditions |
| MTB10 | TtxH | TxCK High Time | Synchronous mode | Greater of: 15 or (Tcy + 15)/N | — | — | ns | Must also meet Parameter TB15 , N = prescale value (1, 8, 64, 256) |
| MTB11 | TtxL | TxCK Low Time | Synchronous mode | Greater of: 15 or (Tcy + 15)/N | — | — | ns | Must also meet Parameter TB15 , N = prescale value (1, 8, 64, 256) |
| MTB15 | TtxP | TxCK Input Period | Synchronous mode | Greater of: 40 or (2 Tcy + 30)/N | — | — | ns | N = prescale value(1, 8, 64, 256) |
| MTB20 | TCKEXTMRL | Delay from External TxCK Clock Edge to Timer Increment | | 0.75 Tcy + 30 | — | 1.75 Tcy + 30 | ns | |

Note 1: These parameters are characterized, but are not tested in manufacturing.

TABLE 28-8: TIMER3/5 EXTERNAL CLOCK TIMING REQUIREMENTS

| AC CHARACTERISTICS | | | | Standard Operating Conditions: 3.0V to 3.6V (unless otherwise stated) Operating temperature $-40^{\circ}\text{C} \leq T_A \leq +85^{\circ}\text{C}$ for Industrial | | | | |
|--------------------|-----------|--|-----------------------------|--|-----|---------------|-------|---|
| Param No. | Symbol | Characteristic ⁽¹⁾ | | Min | Typ | Max | Units | Conditions |
| MTC10 | TtxH | TxCK High Time | Synchronous | Tcy + 10 | — | — | ns | Must also meet Parameter TC15 |
| MTC11 | TtxL | TxCK Low Time | Synchronous | Tcy + 10 | — | — | ns | Must also meet Parameter TC15 |
| MTC15 | TtxP | TxCK Input Period | Synchronous, with prescaler | 2 Tcy + 20 | — | — | ns | |
| MTC20 | TCKEXTMRL | Delay from External TxCK Clock Edge to Timer Increment | | 0.75 Tcy + 20 | — | 1.75 Tcy + 20 | ns | |

Note 1: These parameters are characterized, but are not tested in manufacturing.

dsPIC33FJ32GS406/606/608/610 and dsPIC33FJ64GS406/606/608/610

TABLE 28-9: SIMPLE OCx/PWMx MODE TIMING REQUIREMENTS

| AC CHARACTERISTICS | | | Standard Operating Conditions: 3.0V to 3.6V (unless otherwise stated) Operating temperature $-40^{\circ}\text{C} \leq T_A \leq +85^{\circ}\text{C}$ for Industrial | | | | |
|--------------------|--------|-------------------------------|--|-----|----------------------|-------|------------|
| Param No. | Symbol | Characteristic ⁽¹⁾ | Min | Typ | Max | Units | Conditions |
| MOC15 | TFD | Fault Input to PWM I/O Change | — | — | T _{cy} + 10 | ns | |
| MOC20 | TFLT | Fault Input Pulse Width | T _{cy} + 10 | — | — | ns | |

Note 1: These parameters are characterized but not tested in manufacturing.

29.0 DC AND AC DEVICE CHARACTERISTICS GRAPHS

Note: The graphs provided following this note are a statistical summary based on a limited number of samples and are provided for design guidance purposes only. The performance characteristics listed herein are not tested or guaranteed. In some graphs, the data presented may be outside the specified operating range (e.g., outside specified power supply range) and therefore, outside the warranted range.

FIGURE 29-1: V_{OH} – 4x DRIVER PINS

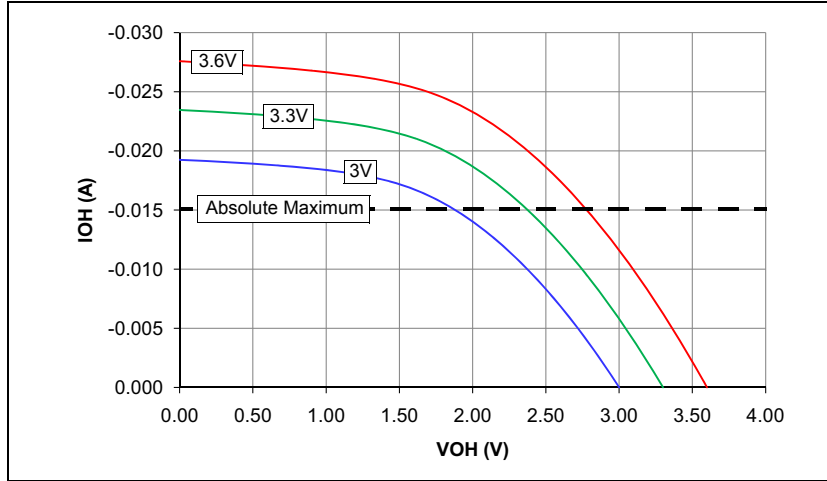

FIGURE 29-3: V_{OH} – 16x DRIVER PINS

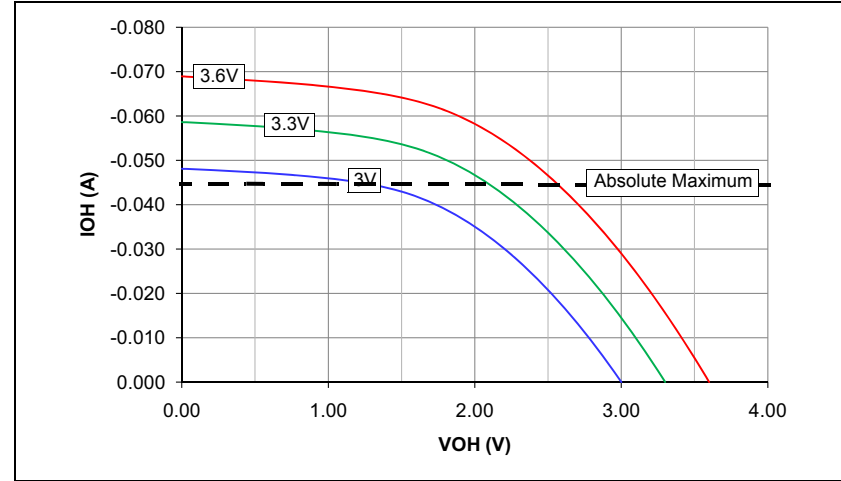

FIGURE 29-2: V_{OH} – 8x DRIVER PINS

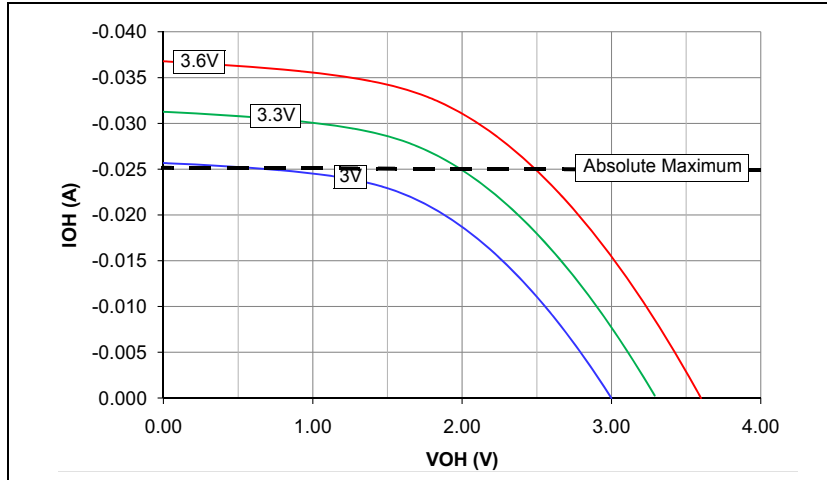

FIGURE 29-4: VOL – 4x DRIVER PINS



FIGURE 29-6: VOL – 16x DRIVER PINS



FIGURE 29-5: VOL – 8x DRIVER PINS



30.0 PACKAGING INFORMATION

30.1 Package Marking Information

64-Lead QFN (9x9x0.9mm)



Example



64-Lead TQFP (10x10x1mm)



Example



80-Lead TQFP (12x12x1mm)



Example



| | | |
|----------------|--|--|
| Legend: | XX...X | Customer-specific information |
| | Y | Year code (last digit of calendar year) |
| | YY | Year code (last 2 digits of calendar year) |
| | WW | Week code (week of January 1 is week '01') |
| | NNN | Alphanumeric traceability code |
| | (e3) | Pb-free JEDEC designator for Matte Tin (Sn) |
| | * (e3) | This package is Pb-free. The Pb-free JEDEC designator ((e3)) can be found on the outer packaging for this package. |
| Note: | If the full Microchip part number cannot be marked on one line, it is carried over to the next line, thus limiting the number of available characters for customer-specific information. | |

30.1 Package Marking Information (Continued)

100-Lead TQFP (12x12x1 mm)



Example

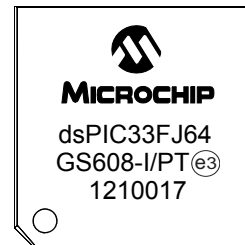

100-Lead TQFP (14x14x1mm)



Example

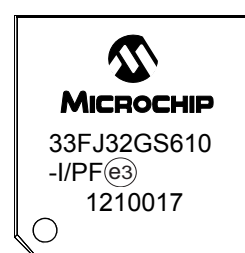

30.2 Package Details

64-Lead Plastic Quad Flat, No Lead Package (MR) – 9x9x0.9 mm Body [QFN]
With 7.15 x 7.15 Exposed Pad [QFN]

Note: For the most current package drawings, please see the Microchip Packaging Specification located at <http://www.microchip.com/packaging>

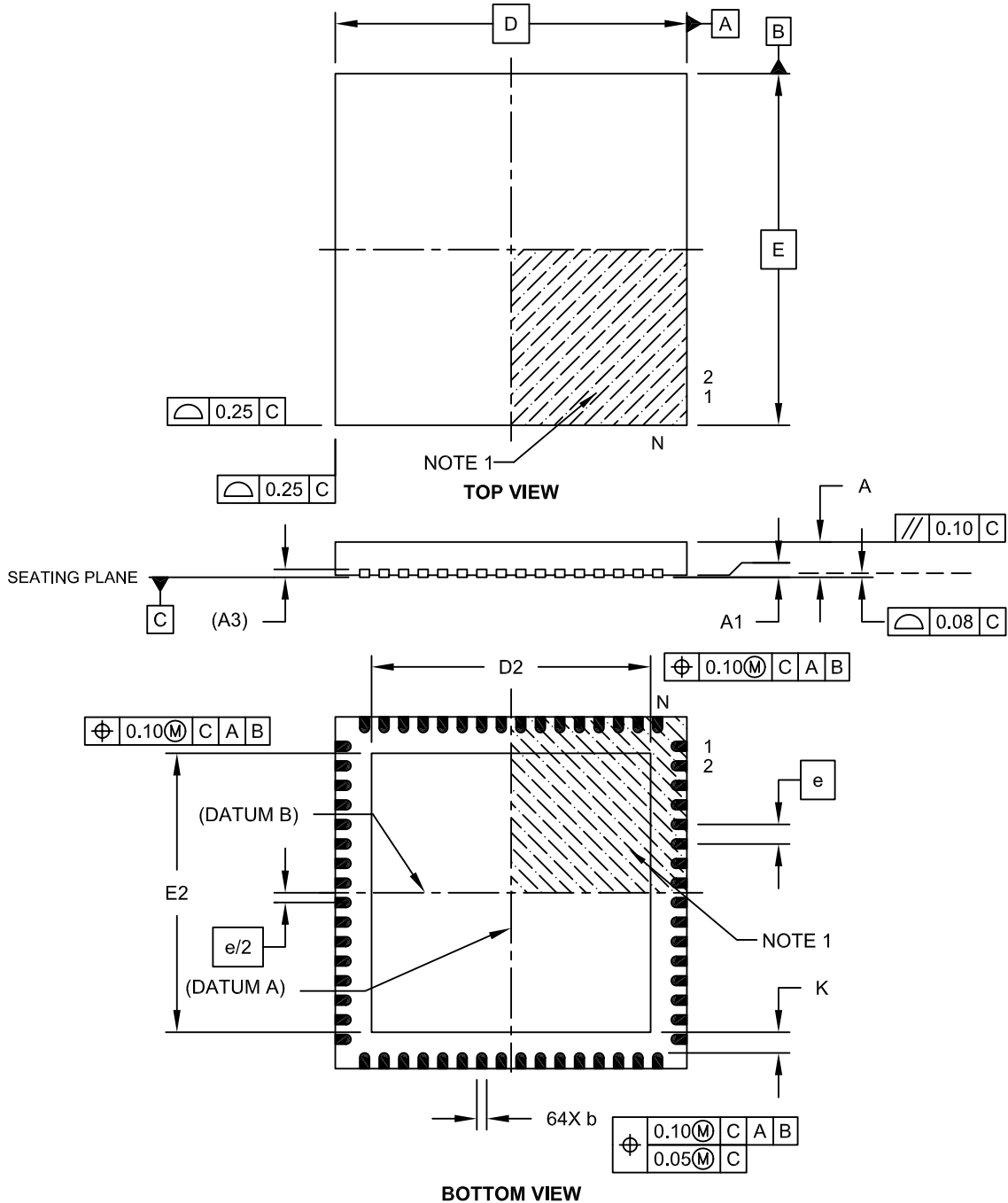

dsPIC33FJ32GS406/606/608/610 and dsPIC33FJ64GS406/606/608/610

64-Lead Plastic Quad Flat, No Lead Package (MR) – 9x9x0.9 mm Body [QFN] With 7.15 x 7.15 Exposed Pad [QFN]

Note: For the most current package drawings, please see the Microchip Packaging Specification located at <http://www.microchip.com/packaging>



| Dimension Limits | Units | MILLIMETERS | | |
|------------------------|-------|-------------|------|------|
| | | MIN | NOM | MAX |
| Number of Pins | N | 64 | | |
| Pitch | e | 0.50 BSC | | |
| Overall Height | A | 0.80 | 0.90 | 1.00 |
| Standoff | A1 | 0.00 | 0.02 | 0.05 |
| Contact Thickness | A3 | 0.20 REF | | |
| Overall Width | E | 9.00 BSC | | |
| Exposed Pad Width | E2 | 7.05 | 7.15 | 7.50 |
| Overall Length | D | 9.00 BSC | | |
| Exposed Pad Length | D2 | 7.05 | 7.15 | 7.50 |
| Contact Width | b | 0.18 | 0.25 | 0.30 |
| Contact Length | L | 0.30 | 0.40 | 0.50 |
| Contact-to-Exposed Pad | K | 0.20 | - | - |

Notes:

1. Pin 1 visual index feature may vary, but must be located within the hatched area.
2. Package is saw singulated.
3. Dimensioning and tolerancing per ASME Y14.5M.

BSC: Basic Dimension, Theoretically exact value shown without tolerances.

REF: Reference Dimension, usually without tolerance, for information purposes only.

Microchip Technology Drawing C04-149C Sheet 2 of 2

dsPIC33FJ32GS406/606/608/610 and dsPIC33FJ64GS406/606/608/610

64-Lead Plastic Quad Flat, No Lead Package (MR) – 9x9x0.9 mm Body [QFN]
With 0.40 mm Contact Length

Note: For the most current package drawings, please see the Microchip Packaging Specification located at <http://www.microchip.com/packaging>



RECOMMENDED LAND PATTERN

| Dimension Limits | Units | MILLIMETERS | | |
|----------------------------|-------|-------------|------|------|
| | | MIN | NOM | MAX |
| Contact Pitch | E | 0.50 BSC | | |
| Optional Center Pad Width | W2 | | | 7.35 |
| Optional Center Pad Length | T2 | | | 7.35 |
| Contact Pad Spacing | C1 | | 8.90 | |
| Contact Pad Spacing | C2 | | 8.90 | |
| Contact Pad Width (X64) | X1 | | | 0.30 |
| Contact Pad Length (X64) | Y1 | | | 0.85 |
| Distance Between Pads | G | 0.20 | | |

Notes:

1. Dimensioning and tolerancing per ASME Y14.5M

BSC: Basic Dimension. Theoretically exact value shown without tolerances.

Microchip Technology Drawing No. C04-2149A

64-Lead Plastic Thin Quad Flatpack (PT) – 10x10x1 mm Body, 2.00 mm [TQFP]

Note: For the most current package drawings, please see the Microchip Packaging Specification located at <http://www.microchip.com/packaging>



| Dimension Limits | Units | MILLIMETERS | | |
|--------------------------|-------|-------------|------|------|
| | | MIN | NOM | MAX |
| Number of Leads | N | 64 | | |
| Lead Pitch | e | 0.50 BSC | | |
| Overall Height | A | – | – | 1.20 |
| Molded Package Thickness | A2 | 0.95 | 1.00 | 1.05 |
| Standoff | A1 | 0.05 | – | 0.15 |
| Foot Length | L | 0.45 | 0.60 | 0.75 |
| Footprint | L1 | 1.00 REF | | |
| Foot Angle | φ | 0° | 3.5° | 7° |
| Overall Width | E | 12.00 BSC | | |
| Overall Length | D | 12.00 BSC | | |
| Molded Package Width | E1 | 10.00 BSC | | |
| Molded Package Length | D1 | 10.00 BSC | | |
| Lead Thickness | c | 0.09 | – | 0.20 |
| Lead Width | b | 0.17 | 0.22 | 0.27 |
| Mold Draft Angle Top | α | 11° | 12° | 13° |
| Mold Draft Angle Bottom | β | 11° | 12° | 13° |

Notes:

1. Pin 1 visual index feature may vary, but must be located within the hatched area.
2. Chamfers at corners are optional; size may vary.
3. Dimensions D1 and E1 do not include mold flash or protrusions. Mold flash or protrusions shall not exceed 0.25 mm per side.
4. Dimensioning and tolerancing per ASME Y14.5M.

BSC: Basic Dimension. Theoretically exact value shown without tolerances.

REF: Reference Dimension, usually without tolerance, for information purposes only.

Microchip Technology Drawing C04-085B

dsPIC33FJ32GS406/606/608/610 and dsPIC33FJ64GS406/606/608/610

64-Lead Plastic Thin Quad Flatpack (PT) 10x10x1 mm Body, 2.00 mm Footprint [TQFP]

Note: For the most current package drawings, please see the Microchip Packaging Specification located at <http://www.microchip.com/packaging>



RECOMMENDED LAND PATTERN

| | | Units | MILLIMETERS | | |
|--------------------------|----|-------|-------------|-------|------|
| Dimension Limits | | | MIN | NOM | MAX |
| Contact Pitch | E | | 0.50 BSC | | |
| Contact Pad Spacing | C1 | | | 11.40 | |
| Contact Pad Spacing | C2 | | | 11.40 | |
| Contact Pad Width (X64) | X1 | | | | 0.30 |
| Contact Pad Length (X64) | Y1 | | | | 1.50 |
| Distance Between Pads | G | 0.20 | | | |

Notes:

1. Dimensioning and tolerancing per ASME Y14.5M

BSC: Basic Dimension. Theoretically exact value shown without tolerances.

Microchip Technology Drawing No. C04-2085B

dsPIC33FJ32GS406/606/608/610 and dsPIC33FJ64GS406/606/608/610

80-Lead Plastic Thin Quad Flatpack (PT) – 12x12x1 mm Body, 2.00 mm [TQFP]

Note: For the most current package drawings, please see the Microchip Packaging Specification located at <http://www.microchip.com/packaging>



| Dimension Limits | Units | MILLIMETERS | | |
|--------------------------|----------|-------------|------|------|
| | | MIN | NOM | MAX |
| Number of Leads | N | 80 | | |
| Lead Pitch | e | 0.50 BSC | | |
| Overall Height | A | – | – | 1.20 |
| Molded Package Thickness | A2 | 0.95 | 1.00 | 1.05 |
| Standoff | A1 | 0.05 | – | 0.15 |
| Foot Length | L | 0.45 | 0.60 | 0.75 |
| Footprint | L1 | 1.00 REF | | |
| Foot Angle | ϕ | 0° | 3.5° | 7° |
| Overall Width | E | 14.00 BSC | | |
| Overall Length | D | 14.00 BSC | | |
| Molded Package Width | E1 | 12.00 BSC | | |
| Molded Package Length | D1 | 12.00 BSC | | |
| Lead Thickness | c | 0.09 | – | 0.20 |
| Lead Width | b | 0.17 | 0.22 | 0.27 |
| Mold Draft Angle Top | α | 11° | 12° | 13° |
| Mold Draft Angle Bottom | β | 11° | 12° | 13° |

Notes:

1. Pin 1 visual index feature may vary, but must be located within the hatched area.
2. Chamfers at corners are optional; size may vary.
3. Dimensions D1 and E1 do not include mold flash or protrusions. Mold flash or protrusions shall not exceed 0.25 mm per side.
4. Dimensioning and tolerancing per ASME Y14.5M.

BSC: Basic Dimension. Theoretically exact value shown without tolerances.

REF: Reference Dimension, usually without tolerance, for information purposes only.

Microchip Technology Drawing C04-092B

dsPIC33FJ32GS406/606/608/610 and dsPIC33FJ64GS406/606/608/610

80-Lead Plastic Thin Quad Flatpack (PT) - 12x12x1mm Body, 2.00 mm Footprint [TQFP]

Note: For the most current package drawings, please see the Microchip Packaging Specification located at <http://www.microchip.com/packaging>



| Dimension Limits | Units | MILLIMETERS | | |
|--------------------------|-------|-------------|-------|------|
| | | MIN | NOM | MAX |
| Contact Pitch | E | 0.50 BSC | | |
| Contact Pad Spacing | C1 | | 13.40 | |
| Contact Pad Spacing | C2 | | 13.40 | |
| Contact Pad Width (X80) | X1 | | | 0.30 |
| Contact Pad Length (X80) | Y1 | | | 1.50 |
| Distance Between Pads | G | 0.20 | | |

Notes:

1. Dimensioning and tolerancing per ASME Y14.5M

BSC: Basic Dimension. Theoretically exact value shown without tolerances.

Microchip Technology Drawing No. C04-2092B

dsPIC33FJ32GS406/606/608/610 and dsPIC33FJ64GS406/606/608/610

100-Lead Plastic Thin Quad Flatpack (PT) – 12x12x1 mm Body, 2.00 mm [TQFP]

Note: For the most current package drawings, please see the Microchip Packaging Specification located at <http://www.microchip.com/packaging>



| Dimension Limits | Units | MILLIMETERS | | |
|--------------------------|-------|-------------|------|------|
| | | MIN | NOM | MAX |
| Number of Leads | N | 100 | | |
| Lead Pitch | e | 0.40 BSC | | |
| Overall Height | A | – | – | 1.20 |
| Molded Package Thickness | A2 | 0.95 | 1.00 | 1.05 |
| Standoff | A1 | 0.05 | – | 0.15 |
| Foot Length | L | 0.45 | 0.60 | 0.75 |
| Footprint | L1 | 1.00 REF | | |
| Foot Angle | φ | 0° | 3.5° | 7° |
| Overall Width | E | 14.00 BSC | | |
| Overall Length | D | 14.00 BSC | | |
| Molded Package Width | E1 | 12.00 BSC | | |
| Molded Package Length | D1 | 12.00 BSC | | |
| Lead Thickness | c | 0.09 | – | 0.20 |
| Lead Width | b | 0.13 | 0.18 | 0.23 |
| Mold Draft Angle Top | α | 11° | 12° | 13° |
| Mold Draft Angle Bottom | β | 11° | 12° | 13° |

Notes:

- Pin 1 visual index feature may vary, but must be located within the hatched area.
- Chamfers at corners are optional; size may vary.
- Dimensions D1 and E1 do not include mold flash or protrusions. Mold flash or protrusions shall not exceed 0.25 mm per side.
- Dimensioning and tolerancing per ASME Y14.5M.

BSC: Basic Dimension. Theoretically exact value shown without tolerances.

REF: Reference Dimension, usually without tolerance, for information purposes only.

Microchip Technology Drawing C04-100B

dsPIC33FJ32GS406/606/608/610 and dsPIC33FJ64GS406/606/608/610

100-Lead Plastic Thin Quad Flatpack (PT)- 12x12x1mm Body, 2.00 mm Footprint [TQFP]

Note: For the most current package drawings, please see the Microchip Packaging Specification located at <http://www.microchip.com/packaging>



| Dimension Limits | Units | MILLIMETERS | | |
|---------------------------|-------|-------------|-------|------|
| | | MIN | NOM | MAX |
| Contact Pitch | E | 0.40 BSC | | |
| Contact Pad Spacing | C1 | | 13.40 | |
| Contact Pad Spacing | C2 | | 13.40 | |
| Contact Pad Width (X100) | X1 | | | 0.20 |
| Contact Pad Length (X100) | Y1 | | | 1.50 |
| Distance Between Pads | G | 0.20 | | |

Notes:

1. Dimensioning and tolerancing per ASME Y14.5M

BSC: Basic Dimension. Theoretically exact value shown without tolerances.

Microchip Technology Drawing No. C04-2100B

dsPIC33FJ32GS406/606/608/610 and dsPIC33FJ64GS406/606/608/610

100-Lead Plastic Thin Quad Flatpack (PF) – 14x14x1 mm Body, 2.00 mm [TQFP]

Note: For the most current package drawings, please see the Microchip Packaging Specification located at <http://www.microchip.com/packaging>



| Dimension Limits | Units | MILLIMETERS | | |
|--------------------------|----------|-------------|------|------|
| | | MIN | NOM | MAX |
| Number of Leads | N | 100 | | |
| Lead Pitch | e | 0.50 BSC | | |
| Overall Height | A | – | – | 1.20 |
| Molded Package Thickness | A2 | 0.95 | 1.00 | 1.05 |
| Standoff | A1 | 0.05 | – | 0.15 |
| Foot Length | L | 0.45 | 0.60 | 0.75 |
| Footprint | L1 | 1.00 REF | | |
| Foot Angle | ϕ | 0° | 3.5° | 7° |
| Overall Width | E | 16.00 BSC | | |
| Overall Length | D | 16.00 BSC | | |
| Molded Package Width | E1 | 14.00 BSC | | |
| Molded Package Length | D1 | 14.00 BSC | | |
| Lead Thickness | c | 0.09 | – | 0.20 |
| Lead Width | b | 0.17 | 0.22 | 0.27 |
| Mold Draft Angle Top | α | 11° | 12° | 13° |
| Mold Draft Angle Bottom | β | 11° | 12° | 13° |

Notes:

- Pin 1 visual index feature may vary, but must be located within the hatched area.
- Chamfers at corners are optional; size may vary.
- Dimensions D1 and E1 do not include mold flash or protrusions. Mold flash or protrusions shall not exceed 0.25 mm per side.
- Dimensioning and tolerancing per ASME Y14.5M.

BSC: Basic Dimension. Theoretically exact value shown without tolerances.

REF: Reference Dimension, usually without tolerance, for information purposes only.

Microchip Technology Drawing C04-110B

dsPIC33FJ32GS406/606/608/610 and dsPIC33FJ64GS406/606/608/610

100-Lead Plastic Thin Quad Flatpack (PF) - 14x14x1 mm Body 2.00 mm Footprint [TQFP]

Note: For the most current package drawings, please see the Microchip Packaging Specification located at <http://www.microchip.com/packaging>



| Dimension Limits | Units | MILLIMETERS | | |
|---------------------------|-------|-------------|-------|------|
| | | MIN | NOM | MAX |
| Contact Pitch | E | 0.50 BSC | | |
| Contact Pad Spacing | C1 | | 15.40 | |
| Contact Pad Spacing | C2 | | 15.40 | |
| Contact Pad Width (X100) | X1 | | | 0.30 |
| Contact Pad Length (X100) | Y1 | | | 1.50 |
| Distance Between Pads | G | 0.20 | | |

Notes:

1. Dimensioning and tolerancing per ASME Y14.5M

BSC: Basic Dimension. Theoretically exact value shown without tolerances.

Microchip Technology Drawing No. C04-2110B

NOTES:

APPENDIX A: MIGRATING FROM dsPIC33FJ06GS101/X02 AND dsPIC33FJ16GSX02/X04 TO dsPIC33FJ32GS406/606/608/610 AND dsPIC33FJ64GS406/606/608/610 DEVICES

This appendix provides an overview of considerations for migrating from the dsPIC33FJ06GS101/X02 and dsPIC33FJ16GSX02/X04 family of devices to the dsPIC33FJ32GS406/606/608/610 and dsPIC33FJ64GS406/606/608/610 family of devices. The code developed for the dsPIC33FJ06GS101/X02 and dsPIC33FJ16GSX02/X04 devices can be ported to the dsPIC33FJ32GS406/606/608/610 and dsPIC33FJ64GS406/606/608/610 devices after making the appropriate changes outlined below.

A.1 Device Pins and Peripheral Pin Select (PPS)

On dsPIC33FJ06GS101/X02 and dsPIC33FJ16GSX02/X04 devices, some peripherals such as the Timer, Input Capture, Output Compare, UART, SPI, External Interrupts, Analog Comparator Output, as well as the PWM4 pin pair, were mapped to physical pins via Peripheral Pin Select (PPS) functionality. On dsPIC33FJ32GS406/606/608/610 and dsPIC33FJ64GS406/606/608/610 devices, these peripherals are hard-coded to dedicated pins. Because of this, as well as pinout differences between the two devices families, software must be updated to utilize peripherals on the desired pin locations.

A.2 High-Speed PWM

A.2.1 FAULT AND CURRENT-LIMIT CONTROL SIGNAL SOURCE SELECTION

Fault and Current-Limit Control Signal Source selection has changed between the two families of devices. On dsPIC33FJ06GS101/X02 and dsPIC33FJ16GSX02/X04 devices, Fault1 through Fault8 were assigned to Fault and Current-Limit Controls with the following values:

- 00000 = Fault 1
- 00001 = Fault 2
- 00010 = Fault 3
- 00011 = Fault 4
- 00100 = Fault 5
- 00101 = Fault 6
- 00110 = Fault 7
- 00111 = Fault 8

On dsPIC33FJ32GS406/606/608/610 and dsPIC33FJ64GS406/606/608/610 devices, Fault1 through Fault8 were assigned to Fault and Current-Limit Controls with the following values:

- 01000 = Fault 1
- 01001 = Fault 2
- 01010 = Fault 3
- 01011 = Fault 4
- 01100 = Fault 5
- 01101 = Fault 6
- 01110 = Fault 7
- 01111 = Fault 8

A.2.2 ANALOG COMPARATORS CONNECTION

Connection of analog comparators to the PWM Fault and Current-Limit Control Signal Sources on dsPIC33FJ06GS101/X02 and dsPIC33FJ16GSX02/X04 devices is performed by assigning a comparator to one of the Fault sources via the virtual PPS pins, and then selecting the desired Fault as the source for Fault and Current-Limit Control. On dsPIC33FJ32GS406/606/608/610 and dsPIC33FJ64GS406/606/608/610 devices, analog comparators have a direct connection to Fault and Current-Limit Control, and can be selected with the following values for the CLSRC or FLTSRC bits:

- 00000 = Analog Comparator 1
- 00001 = Analog Comparator 2
- 00010 = Analog Comparator 3
- 00011 = Analog Comparator 4

A.2.3 LEADING-EDGE BLANKING (LEB)

The Leading-Edge Blanking Delay (LEB) bits have been moved from the LEBCOx register on dsPIC33FJ06GS101/X02 and dsPIC33FJ16GSX02/X04 devices to the LEBDLYx register on dsPIC33FJ32GS406/606/608/610 and dsPIC33FJ64GS406/606/608/610 devices.

APPENDIX B: REVISION HISTORY

Revision B (November 2009)

Revision A (March 2009)

This is the initial release of this document.

The revision includes the following global update:

- Added Note 2 to the shaded table that appears at the beginning of each chapter. This new note provides information regarding the availability of registers and their associated bits

This revision also includes minor typographical and formatting changes throughout the data sheet text.

All other major changes are referenced by their respective section in [Table B-1](#).

TABLE B-1: MAJOR SECTION UPDATES

| Section Name | Update Description |
|--|---|
| “High-Performance, 16-bit Digital Signal Controllers” | <p>Added “DMA Channels” column and updated the RAM size to 9K for the dsPIC33FJ64GS406 devices in the controller families table (see Table 1).</p> <p>Updated the pin diagrams as follows:</p> <ul style="list-style-type: none"> • 64-pin TQFP and QFN <ul style="list-style-type: none"> - Removed FLT8 from pin 51 - Added FLT8 to pin 60 - Added FLT17 to pin 31 - Added FLT18 to pin32 • 80-pin TQFP <ul style="list-style-type: none"> - Removed FLT8 from pin 63 - Added FLT8 to pin 76 - Added FLT19 to pin 53 - Added FLT20 to pin 52 • 100-pin TQFP <ul style="list-style-type: none"> - Removed FLT8 from pin 78 - Added FLT8 to pin 93 - Added SYNCO1 to pin 95 |
| Section 4.0 “Memory Organization” | <p>Added Data Memory Map for Devices with 8 KB RAM (see Figure 4-4).</p> <p>Removed SFRs IPC25 and IPC26 from the Interrupt Controller Register Map for dsPIC33FJ32GS406 and dsPIC33FJ64GS406 devices (see Table 4-7).</p> <p>The following bits in the Interrupt Controller Register Map for dsPIC33FJ32GS406 and dsPIC33FJ64GS406 devices were changed to unimplemented (see Table 4-7):</p> <ul style="list-style-type: none"> • Bit 2 of IFS1 • Bits 9-7 of IFS6 • Bit 2 of IEC1 • Bits 9-7 of IEC6 • Bits 10-8 of IPC4 <p>Removed OSCTUN2 and LFSR, updated OSCCON and OSCTUN, renamed bit 13 of the REFOCON SFR in the System Control Register Map from ROSIDL to ROSSLP and changed the All Resets value from ‘0000’ to ‘2300’ for the ACLKCON SFR (see Table 4-56).</p> <p>Updated bit 1 of the PMD Register Map for dsPIC33FJ64GS608 devices from unimplemented to C1MD (see Table 4-60).</p> |

TABLE B-1: MAJOR SECTION UPDATES (CONTINUED)

| Section Name | Update Description |
|---|--|
| Section 9.0 “Oscillator Configuration” | <p>Removed Section 9.2 “FRC Tuning”.</p> <p>Removed the PRCDEN, TSEQEN, and LPOSCEN bits from the Oscillator Control Register (see Register 9-1).</p> <p>Updated the Oscillator Tuning Register (see Register 9-4).</p> <p>Removed the Oscillator Tuning Register 2 and the Linear Feedback Shift Register.</p> <p>Updated the default Reset values from R/W-0 to R/W-1 for the SELACLK and APSTSCLR<2:0> bits in the ACLKCON register (see Register 9-5).</p> <p>Renamed the ROSIDL bit to ROSSLP in the REFOCON register (see Register 9-6).</p> |
| Section 10.0 “Power-Saving Features” | <p>Updated the last paragraph of Section 10.2.2 “Idle Mode” to clarify when instruction execution begins.</p> <p>Added Note 1 to the PMD1 register (see Register 10-1).</p> |
| Section 11.0 “I/O Ports” | <p>Changed the reference to digital-only pins to 5V tolerant pins in the second paragraph of Section 11.2 “Open-Drain Configuration”.</p> |
| Section 16.0 “High-Speed PWM” | <p>Updated the High-Speed PWM Module Register Interconnect Diagram (see Figure 16-2).</p> <p>Updated the SYNC SRC<2:0> = 111, 101, and 100 definitions to Reserved in the PTCON and STCON registers (see Register 16-1 and Register 16-5).</p> <p>Updated the PWM time base maximum value from 0xFFFFB to 0xFFFF8 in the PTPER register (Register 16-3).</p> <p>Updated the smallest pulse width value from 0x0008 to 0x0009 in Note 1 of the shaded note that follows the MDC register (see Register 16-10).</p> <p>Updated the smallest pulse width value from 0x0008 to 0x0009 in Note 2 of the shaded note that follows the PDCx and SDCx registers (see Register 16-12 and Register 16-13).</p> <p>Added Note 2 and updated the FLTDAT<1:0> and CLDAT<1:0> bits, changing the word ‘data’ to ‘state’ in the IOCONx register (see Register 16-19).</p> |
| Section 20.0 “Universal Asynchronous Receiver Transmitter (UART)” | <p>Updated the two baud rate range features to: 10 Mbps to 38 bps at 40 MIPS.</p> |
| Section 22.0 “High-Speed 10-bit Analog-to-Digital Converter (ADC)” | <p>Updated the TRGSRCx<4:0> = 01101 definition from Reserved to PWM secondary special event trigger selected, and updated Note 1 in the ADCP0-ADCP6 registers (see Register 22-6 through Register 22-12).</p> |
| Section 24.0 “Special Features” | <p>Updated the second paragraph and removed the fourth paragraph in Section 24.1 “Configuration Bits”.</p> <p>Updated the Device Configuration Register Map (see Table 24-1).</p> |

dsPIC33FJ32GS406/606/608/610 and dsPIC33FJ64GS406/606/608/610

TABLE B-1: MAJOR SECTION UPDATES (CONTINUED)

| Section Name | Update Description |
|---|---|
| <p>Section 27.0 “Electrical Characteristics”</p> | <p>Updated the Absolute Maximum Ratings for high temperature and added Note 4.</p> <p>Updated all Operating Current (IDD) Typical and Max values in Table 27-5.</p> <p>Updated all Idle Current (IDLE) Typical and Max values in Table 27-6.</p> <p>Updated all Power-Down Current (IPD) Typical and Max values in Table 27-7.</p> <p>Updated all Doze Current (IDOZE) Typical and Max values in Table 27-8.</p> <p>Updated the Typ and Max values for parameter D150 and removed parameters DI26, DI28, and DI29 from the I/O Pin Input Specifications (see Table 27-9).</p> <p>Updated the Typ and Max values for parameter DO10 and DO27 and the Min and Typ values for parameter DO20 in the I/O Pin Output Specifications (see Table 27-10).</p> <p>Added parameter numbers to the Auxiliary PLL Clock Timing Specifications (see Table 27-18).</p> <p>Added parameters numbers and updated the Internal RC Accuracy Min, Typ, and Max values (see Table 27-19 and Table 27-20).</p> <p>Added parameter numbers, Note 2, updated the Min and Typ parameter values for MP31 and MP32, and removed the conditions for MP10 and MP11 in the High-Speed PWM Module Timing Requirements (see Table 27-29).</p> <p>Updated the SPIx Module Slave Mode (CKE = 1) Timing Characteristics (see Figure 27-14).</p> <p>Added parameter IM51 to the I2Cx Bus Data Timing Requirements (Master Mode) (see Table 27-34).</p> <p>Updated the Max value for parameter AD33 in the 10-bit High-Speed ADC Module Specifications (see Table 27-36).</p> <p>Updated the titles and added parameter numbers to the Comparator and DAC Module Specifications (see Table 27-38 and Table 27-39) and the DAC Output Buffer Specifications (see Table 27-40).</p> |

Revision C (February 2010)

This revision includes minor typographical and formatting changes throughout the data sheet text.

All other changes are referenced by their respective section in [Table B-2](#).

TABLE B-2: MAJOR SECTION UPDATES

| Section Name | Update Description |
|--|--|
| Section 16.0 “High-Speed PWM” | <p>Added Note 2 to PTPER (Register 16-3).</p> <p>Added Note 1 to SEVTCMP (Register 16-4).</p> <p>Updated Note 1 in MDC (Register 16-10).</p> <p>Updated Note 5 and added Note 6 to PWMCONx (Register 16-11).</p> <p>Updated Note 1 in PDCx (Register 16-12).</p> <p>Updated Note 1 in SDCx (Register 16-13).</p> <p>Updated Note 1 and Note 2 in PHASEx (Register 16-14).</p> <p>Updated Note 2 in SPHASEx (Register 16-15).</p> <p>Updated Note 1 in FCLCONx (Register 16-21).</p> <p>Added Note 1 to STRIGx (Register 16-22).</p> <p>Updated Leading-Edge Blanking Delay increment value from 8.4 ns to 8.32 ns and added a shaded note in LEBDLYx (Register 16-24).</p> <p>Added Note 3 and Note 4 to PWMCAPx (Register 16-26).</p> |
| Section 27.0 “Electrical Characteristics” | <p>Updated the Min and Typ values for the Internal Voltage Regulator specifications in Table 27-13.</p> <p>Updated the Min and Max values for the Internal RC Accuracy specifications in Table 27-20.</p> |

dsPIC33FJ32GS406/606/608/610 and dsPIC33FJ64GS406/606/608/610

Revision D (January 2012)

This revision includes minor typographical and formatting changes throughout the data sheet text.

All occurrences of PGCn and PGDn (where n = 1, 2, or 3) were updated to: PGECn and PGEDn throughout the document.

All other changes are referenced by their respective section in [Table B-3](#).

TABLE B-3: MAJOR SECTION UPDATES

| Section Name | Update Description |
|--|---|
| “16-Bit Digital Signal Controllers with High-Speed PWM, ADC and Comparators” | Added 50 MIPS to Operating Range. Changed the Oscillator frequency range in System Management. Added the “Referenced Sources” section. |
| Section 1.0 “Device Overview” | Updated the block diagram of the core and peripheral modules (see Figure 1-1). |
| Section 2.0 “Guidelines for Getting Started with 16-Bit Digital Signal Controllers” | Updated the Recommended Minimum Connection diagram (see Figure 2-1). Updated the VCAP pin capacitor specification in Section 2.3 “Capacitor on Internal Voltage Regulator (VCAP)” . |
| Section 4.0 “Memory Organization” | Removed IPC20 and updated IFS5, IFS7, IEC5, IEC7, and IPC29 in the Interrupt Controller Register Map for dsPIC33FJ64GS606 devices (see Table 4-6). Removed IPC20 and IPC21 and updated IFS5, IFS7, IEC5, IEC7, and IPC29 in the Interrupt Controller Register Map for dsPIC33FJ32GS406 and dsPIC33FJ64GS406 devices (see Table 4-7). Removed IPC20 and updated IFS5, IFS7, IEC5, IEC7, and IPC29 in the Interrupt Controller Register Map for dsPIC33FJ32GS606 devices (see Table 4-10). Added High-Speed 10-bit ADC Register Map for dsPIC33FJ32GS406 and dsPIC33FJ64GS406 devices (see Table 4-35). Updated ODCG in PORTG Register Map for dsPIC33FJ32GS610 and dsPIC33FJ64GS610 devices (see Table 4-54). Updated ODCG in PORTG Register Map for dsPIC33FJ32GS608 and dsPIC33FJ64GS608 devices (see Table 4-55). Updated ODCG in PORTG Register Map for dsPIC33FJ32GS406/606 and dsPIC33FJ64GS406/606 devices (see Table 4-56). |
| Section 9.0 “Oscillator Configuration” | Changed the High-Speed Crystal (HS) frequency range in Section 9.1.1 “System Clock sources” . Updated the device operating speed to up to 50 MHz in Section 9.1.2 “System Clock Selection” . Updated Section 9.1.3 “PLL Configuration” to reflect the new operating range/speed of 50 MIPS/50 MHz. Updated Section 9.2 “Auxiliary Clock Generation” . |
| Section 22.0 “High-Speed, 10-Bit Analog-to-Digital Converter (ADC)” | Updated the ADC Block Diagram for dsPIC33FJ32GS406 and dsPIC33FJ64GS406 Devices with one SAR (see Table 22-1). Added Note 2 to ADCPC6: ADC Convert Pair Control Register 6 (see Register 22-12). |

TABLE B-3: MAJOR SECTION UPDATES (CONTINUED)

| Section Name | Update Description |
|--|---|
| Section 23.0 “High-Speed Analog Comparator” | Added Note 1 to the High-Speed Analog Comparator Module block diagram (see Figure 23-1). |
| Section 24.0 “Special Features” | <p>Updated Section 24.1 “Configuration Bits”.</p> <p>Added the RTSP Effect column to the dsPIC33F Configuration Bits Description (see Table 24-2).</p> <p>Added Note 3 to the Connections for the On-chip Voltage Regulator (see Figure 24-1).</p> |
| Section 27.0 “Electrical Characteristics” | <p>Updated the Absolute Maximum Ratings.</p> <p>Updated the Operating MIPS vs. Voltage and added Note 1 (see Table 27-1).</p> <p>Updated Note 4 and removed parameter DC18 from the DC Temperature and Voltage Specifications (see Table 27-4).</p> <p>Updated Note 2, Typical and Maximum values for parameters DC20-DC24, and the Conditions for parameters DC25-DC28 in the Operating Current DC Characteristics (see Table 27-5).</p> <p>Updated Note 2 in the Idle Current DC Characteristics (see Table 27-6).</p> <p>Updated Note 2 in the Power-down Current DC Characteristics (see Table 27-7).</p> <p>Added Note 2 to the Doze Current DC Characteristics (see Table 27-8).</p> <p>Added parameters DI60a, DI60b, and DI60c to the I/O Pin Input Specifications (see Table 27-9).</p> <p>Updated all I/O Pin Output Specifications (see Table 27-10).</p> <p>Updated parameter BO10 and added Note 2 and Note 3 to the BOR Electrical Characteristics (see Table 27-11).</p> <p>Added Note 1 to the Internal Voltage Regulator Specifications (see Table 27-13).</p> <p>Updated the OS25 parameter in the External Clock Timing diagram (see Figure 27-2).</p> <p>Added the Secondary Oscillator (SOSC) to parameter OS10, added parameter OS42 (GM), and added Note 2 to the External Clock Timing Requirements (see Table 27-16).</p> <p>Updated Note 2 in the Internal FRC Accuracy AC Characteristics (see Table 27-19).</p> <p>Updated parameters DO31 and DO32 in the I/O Timing Requirements (see Table 27-21).</p> |

dsPIC33FJ32GS406/606/608/610 and dsPIC33FJ64GS406/606/608/610

TABLE B-3: MAJOR SECTION UPDATES (CONTINUED)

| Section Name | Update Description |
|---|---|
| Section 27.0 “Electrical Characteristics” (Continued) | <p>Updated the Timer1, Timer2, and Timer3 External Clock Timing Requirements (see Table 27-23, Table 27-24, and Table 27-25).</p> <p>Updated the Simple OC/PWM Mode Timing Requirements (see Table 27-28).</p> <p>Updated all SPI Timing specifications (see Figure 27-11-Figure 27-18 and Table 27-30-Table 27-37).</p> <p>Added Note 2 to the 10-bit High-Speed ADC Module Specifications (see Table 27-40).</p> <p>Added Note 2 to the 10-bit High-Speed ADC Module Timing Requirements (see Table 27-41).</p> <p>Added parameter DA08 to the DAC Module Specifications (see Table 27-43).</p> <p>Updated parameter DA16 in the DAC Output Buffer Specifications (see Table 27-44).</p> <p>Added DMA Read/Write Timing Requirements (see Table 27-49).</p> |
| Section 28.0 “50 MIPS Electrical Characteristics” | Added new chapter with electrical specifications for 50 MIPS devices. |
| Section 29.0 “DC and AC Device Characteristics Graphs” | Added new chapter. |

Revision E (October 2012)

This revision removes the Preliminary watermark and includes minor typographical and formatting changes throughout the data sheet.

INDEX

A

| | |
|---|-----|
| AC Characteristics | 378 |
| 10-Bit, High-Speed ADC | 406 |
| Internal FRC Accuracy | 381 |
| Internal LPRC Accuracy | 381 |
| Load Conditions | 378 |
| Temperature and Voltage Specifications | 378 |
| Alternate Interrupt Vector Table (AIVT) | 123 |
| Arithmetic Logic Unit (ALU) | 39 |
| Assembler | |
| MPASM Assembler | 362 |

B

| | |
|---|---------------|
| Barrel Shifter | 43 |
| Bit-Reversed Addressing | 102 |
| Example | 103 |
| Implementation | 102 |
| Sequence Table (16-Entry) | 103 |
| Block Diagrams | |
| 16-Bit Timer1 Module | 215 |
| AC-to-DC Power Supply with PFC and 3 Outputs | 32 |
| ADC Module with 1 SAR for dsPIC33FJ32GS406, dsPIC33FJ64GS406 Devices | 311 |
| ADC Module with 2 SARs for dsPIC33FJ32GS606, dsPIC33FJ64GS606 Devices | 312 |
| ADC Module with 2 SARs for dsPIC33FJ32GS608, dsPIC33FJ64GS608 Devices | 313 |
| ADC Module with 2 SARs for dsPIC33FJ32GS610, dsPIC33FJ64GS610 Devices | 314 |
| Boost Converter Implementation | 27 |
| Conceptual High-Speed PWMx | 231 |
| Connections for On-Chip Voltage Regulator | 349 |
| Digital PFC | 27 |
| DMA Top Level System Architecture Using Dedicated Transaction Bus | 178 |
| DSP Engine | 40 |
| dsPIC33FJ32GS406/606/608/610 and dsPIC33FJ64GS406/606/608/610 | 18 |
| dsPIC33FJ32GS406/606/608/610 and dsPIC33FJ64GS406/606/608/610 CPU Core | 34 |
| ECANx Module | 282 |
| High-Speed Analog Comparator x Module | 341 |
| High-Speed PWMx Architecture | 230 |
| I ² C Module | 268 |
| Input Capture x | 223 |
| Interleaved PFC | 30 |
| Multi-Phase Synchronous Buck Converter | 28 |
| Off-Line Ups | 29 |
| Oscillator System | 188 |
| Output Compare Module | 225 |
| Phase-Shifted Full-Bridge Converter | 31 |
| PLL | 190 |
| Quadrature Encoder Interface x | 257 |
| Reset System | 115 |
| Shared Port Structure | 212 |
| Simplified UART Module | 275 |
| Single-Phase Synchronous Buck Converter | 28 |
| SPI Module | 261 |
| Timer2/3/4/5 (32-Bit) | 219 |
| Type B Timer | 217 |
| Type C Timer | 217 |
| Watchdog Timer (WDT) | 350 |
| Brown-out Reset (BOR) | 119, 345, 349 |

C

| | |
|--|----------|
| C Compilers | |
| MPLAB C18 | 362 |
| Clock Generation | |
| Auxiliary | 191 |
| Reference | 191 |
| Clock Switching | 199 |
| Enabling | 199 |
| Sequence | 199 |
| Code Examples | |
| Erasing a Program Memory Page | 113 |
| Initiating a Programming Sequence | 114 |
| Loading Write Buffers | 114 |
| Port Write/Read | 213 |
| PWRSAV Instruction Syntax | 201 |
| Code Protection | 345, 352 |
| CodeGuard Security | 345, 352 |
| Configuration Bits | 345 |
| Description | 346 |
| Configuration Register Map | 345 |
| Configuring Analog Port Pins | 213 |
| CPU | |
| Control Registers | 36 |
| CPU Clocking System | 189 |
| PLL Configuration | 190 |
| Selection | 189 |
| Sources | 189 |
| Customer Change Notification Service | 451 |
| Customer Notification Service | 451 |
| Customer Support | 451 |

D

| | |
|---|-----|
| Data Accumulators and Adder/Subtractor | 41 |
| Data Space Write Saturation | 43 |
| Overflow and Saturation | 41 |
| Round Logic | 42 |
| Write Back | 42 |
| Data Address Space | 47 |
| Alignment | 47 |
| Memory Map for 4-Kbyte RAM Devices | 48 |
| Memory Map for 8-Kbyte RAM Devices | 49 |
| Memory Map for 9-Kbyte RAM Devices | 50 |
| Near Data Space | 47 |
| SFR Space | 47 |
| Software Stack | 99 |
| Width | 47 |
| DC and AC Characteristics | |
| Graphs and Tables | 421 |
| DC Characteristics | |
| Brown-out Reset (BOR) | 376 |
| Doze Current (IDOZE) | 372 |
| I/O Pin Input Specifications | 373 |
| I/O Pin Output Specifications | 375 |
| Idle Current (IDLE) | 370 |
| Internal Voltage Regulator Specifications | 377 |
| Operating Current (IDD) | 368 |
| Operating MIPS vs. Voltage | 366 |
| Power-Down Current (IPD) | 371 |
| Program Memory | 377 |
| Temperature and Voltage Specifications | 367 |

dsPIC33FJ32GS406/606/608/610 and dsPIC33FJ64GS406/606/608/610

| | | | |
|---|----------|--|--|
| DC Characteristics (50 MIPS) | | | |
| Doze Current (IDOZE) | 416 | | |
| Idle Current (IDLE) | 415 | | |
| Operating Current (IDD)..... | 414 | | |
| Operating MIPS vs. Voltage..... | 414 | | |
| Development Support | 361 | | |
| DMA Controller | | | |
| Channel to Peripheral Associations | 177 | | |
| Registers | 178 | | |
| Doze Mode | 202 | | |
| DSP Engine..... | 39 | | |
| Multiplier..... | 41 | | |
| E | | | |
| ECAN Module | | | |
| Frame Types | 281 | | |
| Modes of Operation | 283 | | |
| Overview | 281 | | |
| ECANx Message Buffers | | | |
| ECANx Word 0..... | 305 | | |
| ECANx Word 1..... | 305 | | |
| ECANx Word 2..... | 306 | | |
| ECANx Word 3..... | 306 | | |
| ECANx Word 4..... | 307 | | |
| ECANx Word 5..... | 307 | | |
| ECANx Word 6..... | 308 | | |
| ECANx Word 7..... | 308 | | |
| Electrical Characteristics..... | 365 | | |
| Absolute Maximum Ratings | 365 | | |
| AC Characteristics and Timing Parameters | 378 | | |
| Electrical Characteristics (50 MIPS)..... | 413 | | |
| AC Characteristics and Timing Parameters | 417 | | |
| Enhanced CAN (ECAN) Module | 281 | | |
| Equations | | | |
| Device Operating Frequency | 189 | | |
| Fosc Calculation..... | 190 | | |
| Maximum Row Write Time | 110 | | |
| Minimum Row Write Time | 110 | | |
| Programming Time | 110 | | |
| XT with PLL Mode Example..... | 190 | | |
| Errata | 14 | | |
| External Reset (EXTR)..... | 120 | | |
| F | | | |
| Fail-Safe Clock Monitor (FSCM) | 199 | | |
| Flash Program Memory..... | 109 | | |
| Control Registers | 110 | | |
| Operations | 110 | | |
| Programming Algorithm | 113 | | |
| RTSP Operation..... | 110 | | |
| Table Instructions..... | 109 | | |
| Flexible Configuration | 345 | | |
| G | | | |
| Getting Started with 16-Bit DSCs..... | 23 | | |
| Application Connection Examples | 26 | | |
| Capacitor on Internal Voltage Regulator (VCAP) | 24 | | |
| Configuring Analog and Digital Pins During ICSP Operations | 26 | | |
| Connection Requirements | 23 | | |
| Decoupling Capacitors..... | 23 | | |
| External Oscillator Pins..... | 25 | | |
| ICSP Pins..... | 25 | | |
| Master Clear (MCLR)..... | 24 | | |
| Oscillator Value Conditions on Start-up | 26 | | |
| Unused I/Os | 26 | | |
| H | | | |
| High-Speed Analog Comparator..... | 341 | | |
| Applications | 342 | | |
| Control Registers | 342 | | |
| DAC | 342 | | |
| Output Range | 342 | | |
| Digital Logic | 342 | | |
| Features Overview..... | 341 | | |
| Interaction with I/O Buffers | 342 | | |
| Module Description | 341 | | |
| High-Speed PWM | 229 | | |
| Control Registers..... | 232 | | |
| High-Speed, 10-Bit ADC | | | |
| Control Registers | 310 | | |
| Description | 309 | | |
| Module Functionality..... | 310 | | |
| I | | | |
| I/O Ports..... | 211 | | |
| Parallel I/O (PIO) | 211 | | |
| Write/Read Timing | 213 | | |
| I ² C | | | |
| Operating Modes | 267 | | |
| Registers | 267 | | |
| Illegal Opcode Reset (IOPUWR) | 120 | | |
| In-Circuit Debugger..... | 351 | | |
| In-Circuit Emulation | 345 | | |
| In-Circuit Serial Programming (ICSP)..... | 345, 351 | | |
| Input Capture | 223 | | |
| Control Registers..... | 224 | | |
| Input Change Notification | 213 | | |
| Instruction Addressing Modes | 99 | | |
| File Register Instructions | 99 | | |
| Fundamental Modes Supported | 100 | | |
| MAC Instructions | 100 | | |
| MCU Instructions | 99 | | |
| Move and Accumulator Instructions..... | 100 | | |
| Other Instructions | 100 | | |
| Instruction Set | | | |
| Overview..... | 356 | | |
| Summary | 353 | | |
| Symbols Used in Opcode Descriptions | 354 | | |
| Instruction-Based Power-Saving Modes..... | 201 | | |
| Idle..... | 202 | | |
| Sleep | 201 | | |
| Interfacing Program and Data Memory Spaces..... | 104 | | |
| Internet Address | 451 | | |
| Interrupt Control and Status Registers | 127 | | |
| IECx..... | 127 | | |
| IFSx | 127 | | |
| INTCON1 | 127 | | |
| INTCON2..... | 127 | | |
| INTTREG..... | 127 | | |
| IPCx | 127 | | |
| Interrupt Vector Table (IVT) | 123 | | |
| Interrupts | | | |
| Setup Procedures | 176 | | |
| Initialization | 176 | | |
| Interrupt Disable | 176 | | |
| Interrupt Service Routine | 176 | | |
| Trap Service Routine..... | 176 | | |
| J | | | |
| JTAG Boundary Scan Interface | 345 | | |
| JTAG Interface..... | 351 | | |

dsPIC33FJ32GS406/606/608/610 and dsPIC33FJ64GS406/606/608/610

L

| | |
|----------------------------------|-----|
| Leading-Edge Blanking (LEB)..... | 229 |
| LPRC Oscillator | |
| Use with WDT | 349 |

M

| | |
|---|-----|
| Memory Organization..... | 45 |
| Microchip Internet Web Site..... | 451 |
| Migrating from dsPIC33FJ06GS101/X02 and dsPIC33FJ16GSX02/X04 to dsPIC33FJ32GS406/606/ 608/610 and dsPIC33FJ64GS406/606/608/610 Devices | 437 |
| Migration | |
| Analog Comparators Connection..... | 437 |
| Device Pins and Peripheral Pin Select (PPS)..... | 437 |
| Fault and Current-Limit Control Signal Source Selection..... | 437 |
| Leading-Edge Blanking (LEB)..... | 437 |
| Modes of Operation | |
| Disable | 283 |
| Initialization | 283 |
| Listen All Messages | 283 |
| Listen Only | 283 |
| Loopback | 283 |
| Normal Operation..... | 283 |
| Modulo Addressing | 101 |
| Applicability | 102 |
| Operation Example | 101 |
| Start and End Address..... | 101 |
| W Address Register Selection | 101 |
| MPLAB ASM30 Assembler, Linker, Librarian | 362 |
| MPLAB Integrated Development Environment | |
| Software..... | 361 |
| MPLAB PM3 Device Programmer | 364 |
| MPLAB REAL ICE In-Circuit Emulator System..... | 363 |
| MPLINK Object Linker/MPLIB Object Librarian | 362 |

O

| | |
|--------------------------------|-----|
| Open-Drain Configuration | 213 |
| Oscillator Configuration..... | 187 |
| Control Registers | 192 |
| Output Compare | 225 |
| Modes | 226 |

P

| | |
|--|-----|
| Packaging | 423 |
| Details | 425 |
| Marking | 423 |
| Peripheral Module Disable (PMD) | 203 |
| Pinout I/O Descriptions (table) | 19 |
| Power Save Instructions | |
| Coincident Interrupts..... | 202 |
| Power-on Reset (POR) | 119 |
| Power-Saving Features | 201 |
| Clock Frequency..... | 201 |
| Clock Switching..... | 201 |
| Power-up Timer (PWRT) | 119 |
| Program Address Space..... | 45 |
| Construction..... | 104 |
| Data Access from Program Memory Using Program Space Visibility..... | 107 |
| Data Access from Program Memory Using Table Instructions | 106 |
| Data Access from, Address Generation..... | 105 |
| Memory Maps | 45 |

Table Read High Instructions

| | |
|--------------|-----|
| TBLRDH | 106 |
|--------------|-----|

Table Read Low Instructions

| | |
|-------------|-----|
| TBLRDL..... | 106 |
|-------------|-----|

| | |
|---------------------------|-----|
| Visibility Operation..... | 107 |
|---------------------------|-----|

Program Memory

| | |
|-----------------------|----|
| Interrupt Vector..... | 46 |
|-----------------------|----|

| | |
|--------------------|----|
| Organization | 46 |
|--------------------|----|

| | |
|--------------------|----|
| Reset Vector | 46 |
|--------------------|----|

| | |
|--------------------------|----|
| Programmer's Model | 35 |
|--------------------------|----|

PWM

| | |
|-----------------------------|-----|
| Power-Saving Features | 202 |
|-----------------------------|-----|

Q

| | |
|---|-----|
| Quadrature Encoder Interface (QEI)..... | 257 |
|---|-----|

R

RCON Register

| | |
|--------------------------|-----|
| Use of Status Bits | 121 |
|--------------------------|-----|

| | |
|----------------------|-----|
| Reader Response..... | 452 |
|----------------------|-----|

Register Maps

| | |
|--------------------------------|----|
| Analog Comparator Control..... | 91 |
|--------------------------------|----|

| | |
|---|----|
| Change Notification (dsPIC33FJ32GS406/606 and dsPIC33FJ64GS406/606 Devices)..... | 54 |
|---|----|

| | |
|---|----|
| Change Notification (dsPIC33FJ32GS608/610 and dsPIC33FJ64GS608/601 Devices)..... | 54 |
|---|----|

| | |
|----------------|----|
| CPU Core | 52 |
|----------------|----|

| | |
|----------|----|
| DMA..... | 87 |
|----------|----|

| | |
|-------------------------------------|----|
| ECAN1 (WIN (C1CTRL1) = 0 or 1)..... | 88 |
|-------------------------------------|----|

| | |
|--------------------------------|----|
| ECAN1 (WIN (C1CTRL1) = 0)..... | 88 |
|--------------------------------|----|

| | |
|--------------------------------|----|
| ECAN1 (WIN (C1CTRL1) = 1)..... | 89 |
|--------------------------------|----|

| | |
|--|----|
| High-Speed 10-Bit ADC Module (dsPIC33FJ32GS608 and dsPIC33FJ64GS608 Devices)..... | 84 |
|--|----|

| | |
|--|----|
| High-Speed 10-Bit ADC Module (dsPIC33FJ32GS610 and dsPIC33FJ64GS610 Devices)..... | 82 |
|--|----|

| | |
|--|----|
| High-Speed 10-Bit ADC Module (for dsPIC33FJ32GS406 and dsPIC33FJ64GS406 Devices)..... | 86 |
|--|----|

| | |
|--|----|
| High-Speed 10-Bit ADC Module (for dsPIC33FJ32GS606 and dsPIC33FJ64GS606 Devices)..... | 85 |
|--|----|

| | |
|---------------------|----|
| High-Speed PWM..... | 71 |
|---------------------|----|

| | |
|---------------------------------|----|
| High-Speed PWM Generator 1..... | 71 |
|---------------------------------|----|

| | |
|---------------------------------|----|
| High-Speed PWM Generator 2..... | 72 |
|---------------------------------|----|

| | |
|---------------------------------|----|
| High-Speed PWM Generator 3..... | 73 |
|---------------------------------|----|

| | |
|---------------------------------|----|
| High-Speed PWM Generator 4..... | 74 |
|---------------------------------|----|

| | |
|---------------------------------|----|
| High-Speed PWM Generator 5..... | 75 |
|---------------------------------|----|

| | |
|---------------------------------|----|
| High-Speed PWM Generator 6..... | 76 |
|---------------------------------|----|

| | |
|--|----|
| High-Speed PWM Generator 7 (All devices except dsPIC33FJ32GS406 and dsPIC33FJ64GS406).... | 77 |
|--|----|

| | |
|--|----|
| High-Speed PWM Generator 8 (All devices except dsPIC33FJ32GS406 and dsPIC33FJ64GS406).... | 78 |
|--|----|

| | |
|--|----|
| High-Speed PWM Generator 9 (dsPIC33FJ32GS610 and dsPIC33FJ64GS610 Devices)..... | 79 |
|--|----|

| | |
|------------|----|
| I2C1 | 79 |
|------------|----|

| | |
|------------|----|
| I2C2 | 80 |
|------------|----|

| | |
|--------------------|----|
| Input Capture..... | 69 |
|--------------------|----|

| | |
|--|----|
| Interrupt Controller (dsPIC33FJ32GS406 and dsPIC33FJ64GS406 Devices)..... | 61 |
|--|----|

| | |
|--|----|
| Interrupt Controller (dsPIC33FJ32GS606 Devices) | 67 |
|--|----|

| | |
|--|----|
| Interrupt Controller (dsPIC33FJ32GS608 Devices) | 65 |
|--|----|

| | |
|--|----|
| Interrupt Controller (dsPIC33FJ32GS610 Devices) | 63 |
|--|----|

| | |
|--|----|
| Interrupt Controller (dsPIC33FJ64GS606 Devices) | 59 |
|--|----|

dsPIC33FJ32GS406/606/608/610 and dsPIC33FJ64GS406/606/608/610

| | | | |
|--|-----|---|---------|
| Interrupt Controller (dsPIC33FJ64GS608 Devices)..... | 57 | ADSTAT (ADC Status) | 317 |
| Interrupt Controller (dsPIC33FJ64GS610 Devices)..... | 55 | ALTDTRx (PWM Alternate Dead-Time x)..... | 246 |
| NVM | 96 | AUXCONx (PWM Auxiliary Control x) | 255 |
| Output Compare | 70 | CHOP (PWM Chop Clock Generator) | 239 |
| PMD (dsPIC33FJ64GS606 Devices)..... | 97 | CLKDIV (Clock Divisor) | 194 |
| PMD (dsPIC33FJ32GS406 and dsPIC33FJ64GS406 Devices) | 98 | CMPCONx (Comparator Control x) | 343 |
| PMD (dsPIC33FJ32GS606 Devices)..... | 98 | CMPDACx (Comparator DAC Control x)..... | 344 |
| PMD (dsPIC33FJ32GS608 Devices)..... | 97 | CORCON (Core Control)..... | 38, 128 |
| PMD (dsPIC33FJ32GS610 Devices)..... | 96 | CxBUFNT1 (ECANx Filter 0-3 Buffer Pointer 1)..... | 294 |
| PMD (dsPIC33FJ64GS608 Devices)..... | 97 | CxBUFNT2 (ECANx Filter 4-7 Buffer Pointer 2)..... | 295 |
| PMD (dsPIC33FJ64GS610 Devices)..... | 96 | CxBUFNT3 (ECANx Filter 8-11 Buffer Pointer 3) | 296 |
| PORTA (dsPIC33FJ32GS608 and dsPIC33FJ64GS608 Devices) | 91 | CxBUFNT4 (ECANx Filter 12-15 Buffer Pointer 4) | 297 |
| PORTA (dsPIC33FJ32GS610 and dsPIC33FJ64GS610 Devices) | 91 | CxCFG1 (ECANx Baud Rate Configuration 1) | 292 |
| PORTB..... | 92 | CxCFG2 (ECANx Baud Rate Configuration 2) | 293 |
| PORTC (dsPIC33FJ32GS406/606 and dsPIC33FJ64GS406/606 Devices)..... | 92 | CxCTRL1 (ECANx Control 1) | 284 |
| PORTC (dsPIC33FJ32GS608 and dsPIC33FJ64GS608 Devices) | 92 | CxCTRL2 (ECANx Control 2) | 285 |
| PORTC (dsPIC33FJ32GS610 and dsPIC33FJ64GS610 Devices) | 92 | CxEC (ECANx Transmit/Receive Error Count)..... | 292 |
| PORTD (dsPIC33FJ32GS406/606 and dsPIC33FJ64GS406/606 Devices)..... | 93 | CxFCTRL (ECANx FIFO Control)..... | 287 |
| PORTD (dsPIC33FJ32GS608/610 and dsPIC33FJ64GS608/610 Devices) | 93 | CxFEN1 (ECANx Acceptance Filter Enable 1)..... | 294 |
| PORTE (dsPIC33FJ32GS406/606 and dsPIC33FJ64GS406/606 Devices)..... | 93 | CxFIFO (ECANx FIFO Status)..... | 288 |
| PORTE (dsPIC33FJ32GS608/610 and dsPIC33FJ64GS608/610 Devices)..... | 93 | CxFMSKSEL1 (ECANx Filter 7-0 Mask Selection 1)..... | 299 |
| PORTF (dsPIC33FJ32GS406/606 and dsPIC33FJ64GS406/606 Devices) | 94 | CxFMSKSEL2 (ECANx Filter 15-8 Mask Selection 2)..... | 300 |
| PORTF (dsPIC33FJ32GS608 and dsPIC33FJ64GS608 Devices) | 94 | CxINTE (ECANx Interrupt Enable) | 291 |
| PORTF (dsPIC33FJ32GS610 and dsPIC33FJ64GS610 Devices) | 94 | CxINTF (ECANx Interrupt Flag)..... | 289 |
| PORTG (dsPIC33FJ32GS406/606 and dsPIC33FJ64GS406/606 Devices) | 95 | CxRXFnEID (ECANx Acceptance Filter n Extended Identifier) | 299 |
| PORTG (dsPIC33FJ32GS608 and dsPIC33FJ64GS608 Devices) | 95 | CxRXFnSID (ECANx Acceptance Filter n Standard Identifier) | 298 |
| PORTG (dsPIC33FJ32GS610 and dsPIC33FJ64GS610 Devices) | 94 | CxRXFUL1 (ECANx Receive Buffer Full 1)..... | 302 |
| Quadrature Encoder Interface 1 (QE1)..... | 70 | CxRXFUL2 (ECANx Receive Buffer Full 2)..... | 302 |
| Quadrature Encoder Interface 2 (QE2)..... | 70 | CxRXMnEID (ECANx Acceptance Filter Mask n Extended Identifier) | 301 |
| SPI1 | 81 | CxRXMnSID (ECANx Acceptance Filter Mask n Standard Identifier) | 301 |
| SPI2 | 81 | CxRXOVF1 (ECANx Receive Buffer Overflow 1)..... | 303 |
| System Control | 95 | CxRXOVF2 (ECANx Receive Buffer Overflow 2)..... | 303 |
| Timers | 69 | CxTRmnCON (ECANx TX/RX Buffer mn Control) | 304 |
| UART1 | 80 | CxVEC (ECANx Interrupt Code)..... | 286 |
| UART2 | 80 | DFLTxCON (Digital Filter x Control) | 260 |
| Registers | | DMACS0 (DMA Controller Status 0)..... | 183 |
| ACLKCON (Auxiliary Clock Divisor Control) | 197 | DMACS1 (DMA Controller Status 1)..... | 184 |
| ADBASE (ADC Base) | 318 | DMAxCNT (DMA Channel x Transfer Count) | 182 |
| ADC Base Register (ADBASE)..... | 318 | DMAxCON (DMA Channel x Control)..... | 179 |
| ADCON (ADC Control) | 315 | DMAxPAD (DMA Channel x Peripheral Address) | 181 |
| ADCPC0 (ADC Convert Pair Control 0)..... | 320 | DMAxREQ (DMA Channel x IRQ Select) | 180 |
| ADCPC1 (ADC Convert Pair Control 1)..... | 323 | DMAxSTA (DMA Channel x RAM Start Address Offset A) | 180 |
| ADCPC2 (ADC Convert Pair Control 2)..... | 326 | DMAxSTB (DMA Channel x RAM Start Address Offset B) | 181 |
| ADCPC3 (ADC Convert Pair Control 3)..... | 329 | DSADR (Most Recent DMA RAM Address) | 185 |
| ADCPC4 (ADC Convert Pair Control 4)..... | 332 | DTRx (PWM Dead-Time x)..... | 246 |
| ADCPC5 (ADC Convert Pair Control 5)..... | 335 | FCLCONx (PWM Fault Current-Limit Control x)..... | 250 |
| ADCPC6 (ADC Convert Pair Control 6)..... | 338 | I2CxCON (I2Cx Control)..... | 269 |
| ADPCFG (ADC Port Configuration) | 319 | I2CxMSK (I2Cx Slave Mode Address Mask)..... | 273 |
| ADPCFG2 (ADC Port Configuration 2)..... | 319 | I2CxSTAT (I2Cx Status) | 271 |
| | | ICxCON (Input Capture x Control, x = 1, 2)..... | 224 |
| | | ICxCON (Input Capture x Control)..... | 224 |
| | | IEC0 (Interrupt Enable Control 0) | 141 |
| | | IEC1 (Interrupt Enable Control 1) | 143 |
| | | IEC2 (Interrupt Enable Control 2) | 144 |
| | | IEC3 (Interrupt Enable Control 3) | 145 |
| | | IEC4 (Interrupt Enable Control 4) | 146 |

| | | | |
|---|-----|---|----------|
| IEC5 (Interrupt Enable Control 5) | 147 | SEVTCMP (PWM Special Event Compare) | 236 |
| IEC6 (Interrupt Enable Control 6) | 148 | SPHASEx (PWM Secondary Phase Shift x) | 245 |
| IEC7 (Interrupt Enable Control 7) | 149 | SPIxCON1 (SPIx Control 1) | 263 |
| IFS0 (Interrupt Flag Status 0) | 132 | SPIxCON2 (SPIx Control 2) | 265 |
| IFS1 (Interrupt Flag Status 1) | 134 | SPIxSTAT (SPIx Status and Control) | 262 |
| IFS2 (Interrupt Flag Status 2) | 135 | SR (CPU STATUS) | 128 |
| IFS3 (Interrupt Flag Status 3) | 136 | SR (CPU Status) | 36 |
| IFS4 (Interrupt Flag Status 4) | 137 | SSEVTCMP (PWM Secondary Special Event Compare) | 239 |
| IFS5 (Interrupt Flag Status 5) | 138 | STCON (PWM Secondary Master Time Base Control) | 237 |
| IFS6 (Interrupt Flag Status 6) | 139 | STCON2 (PWM Secondary Clock Divider Select 2) | 238 |
| IFS7 (Interrupt Flag Status 7) | 140 | STPER (Secondary Master Time Base Period) | 238 |
| INTCON1 (Interrupt Control 1) | 129 | STRIGx (PWM Secondary Trigger x Compare Value) | 252 |
| INTCON2 (Interrupt Control 2) | 131 | T1CON (Timer1 Control) | 216 |
| INTTREG (Interrupt Control and Status) | 175 | TRGCONx (PWM Trigger Control x) | 247 |
| IOCONx (PWM I/O Control x) | 248 | TRIGx (PWM Primary Trigger x Compare Value) | 249 |
| IPC0 (Interrupt Priority Control 0) | 150 | TxCON (Timerx Control, x = 2, 4) | 220 |
| IPC1 (Interrupt Priority Control 1) | 151 | TyCON (Timery Control, y = 3, 5) | 221 |
| IPC12 (Interrupt Priority Control 12) | 160 | UxMODE (UARTx Mode) | 276 |
| IPC13 (Interrupt Priority Control 13) | 161 | UxSTA (UARTx Status and Control) | 278 |
| IPC14 (Interrupt Priority Control 14) | 162 | Reset Sequence | 123 |
| IPC16 (Interrupt Priority Control 16) | 163 | Resets | 115 |
| IPC17 (Interrupt Priority Control 17) | 164 | Brown-out Reset (BOR) | 115 |
| IPC18 (Interrupt Priority Control 18) | 165 | Illegal Condition Reset (IOPUWR) | 115 |
| IPC2 (Interrupt Priority Control 2) | 152 | Illegal Opcode | 115, 120 |
| IPC20 (Interrupt Priority Control 20) | 166 | Master Clear Pin Reset (MCLR) | 115 |
| IPC21 (Interrupt Priority Control 21) | 167 | Power-on Reset (POR) | 115 |
| IPC23 (Interrupt Priority Control 23) | 168 | Security Reset | 115 |
| IPC24 (Interrupt Priority Control 24) | 169 | Software RESET Instruction (SWR) | 115 |
| IPC25 (Interrupt Priority Control 25) | 170 | Trap Conflict Reset (TRAPR) | 115 |
| IPC26 (Interrupt Priority Control 26) | 171 | Uninitialized W Register | 115, 120 |
| IPC27 (Interrupt Priority Control 27) | 172 | Watchdog Timer Reset (WDTO) | 115 |
| IPC28 (Interrupt Priority Control 28) | 173 | Revision History | 438 |
| IPC29 (Interrupt Priority Control 29) | 174 | S | |
| IPC3 (Interrupt Priority Control 3) | 153 | Serial Peripheral Interface (SPI) | 261 |
| IPC4 (Interrupt Priority Control 4) | 154 | Software RESET Instruction (SWR) | 120 |
| IPC5 (Interrupt Priority Control 5) | 155 | Software Simulator (MPLAB SIM) | 363 |
| IPC6 (Interrupt Priority Control 6) | 156 | Software Stack Pointer, Frame Pointer CALL Stack Frame | 99 |
| IPC7 (Interrupt Priority Control 7) | 157 | Special Features of the CPU | 345 |
| IPC8 (Interrupt Priority Control 8) | 158 | T | |
| IPC9 (Interrupt Priority Control 9) | 159 | Thermal Operating Conditions | 366 |
| LEBCONx (Leading-Edge Blanking Control x) | 253 | Thermal Packaging Characteristics | 366 |
| LEBDLYx (Leading-Edge Blanking Delay x) | 254 | Timer1 | 215 |
| MDC (PWM Master Duty Cycle) | 240 | Mode Settings | 215 |
| NVMCON (Flash Memory Control) | 111 | Timer2/3/4/5 | 217 |
| NVMKEY (Nonvolatile Memory Key) | 112 | 12-Bit Timer | 218 |
| OCxCON (Output Compare x Control, x = 1, 2) | 227 | 16-Bit Operation | 218 |
| OSCCON (Oscillator Control) | 192 | 32-Bit Operation | 218 |
| OSCTUN (Oscillator Tuning) | 196 | Mode Settings | 218 |
| PDCx (PWM Generator Duty Cycle x) | 243 | Timing Diagrams | |
| PHASEx (PWM Primary Phase Shift x) | 244 | Analog-to-Digital Conversion per Input | 407 |
| PLLFBF (PLL Feedback Divisor) | 195 | Brown-out Situations | 119 |
| PMD1 (Peripheral Module Disable Control 1) | 204 | ECAN I/O | 412 |
| PMD2 (Peripheral Module Disable Control 2) | 206 | External Clock | 379 |
| PMD3 (Peripheral Module Disable Control 3) | 207 | High-Speed PWMx | 389 |
| PMD4 (Peripheral Module Disable Control 4) | 207 | High-Speed PWMx Fault | 389 |
| PMD6 (Peripheral Module Disable Control 6) | 208 | I/O | 382 |
| PMD7 (Peripheral Module Disable Control 7) | 209 | I2Cx Bus Data (Master Mode) | 402 |
| PTCON (PWM Time Base Control) | 233 | I2Cx Bus Data (Slave Mode) | 404 |
| PTCON2 (PWM Clock Divider Select 2) | 235 | I2Cx Bus Start/Stop Bits (Master Mode) | 402 |
| PTPER (Primary Master Time Base Period) | 235 | | |
| PWMCAPx (Primary PWM Time Base Capture x) | 256 | | |
| PWMCONx (PWM Control x) | 241 | | |
| QEIxCON (QEIx Control, x = 1 or 2) | 258 | | |
| RCON (Reset Control) | 116 | | |
| REFOCN (Reference Oscillator Control) | 198 | | |
| SDCx (PWM Secondary Duty Cycle x) | 243 | | |

dsPIC33FJ32GS406/606/608/610 and dsPIC33FJ64GS406/606/608/610

| | | | |
|--|-----|---|----------|
| I2Cx Bus Start/Stop Bits (Slave Mode) | 404 | Timing Requirements (50 MIPS) | |
| Input Capture x (ICx)..... | 387 | External Clock..... | 417 |
| OCx/PWMx | 388 | Simple OCx/PWMx Mode..... | 420 |
| Output Compare Operation..... | 226 | Timer1 External Clock | 418 |
| Output Compare x (OCx) | 387 | Timer2/4 External Clock | 419 |
| QEA/QEB Input..... | 409 | Timer3/5 External Clock | 419 |
| QEI Module Index Pulse | 410 | Timing Specifications | |
| Reset, Watchdog Timer, Oscillator Start-up Timer and Power-up Timer | 383 | Comparator Module | 408 |
| SPIx Master Mode (Full-Duplex, CKE = 0, CKP = x, SMP = 1)..... | 393 | DAC Module | 408 |
| SPIx Master Mode (Full-Duplex, CKE = 1, CKP = x, SMP = 1)..... | 392 | DAC Output Buffer..... | 409 |
| SPIx Master Mode (Half-Duplex, Transmit Only, CKE = 0) | 390 | Trap Conflict Reset (TRAPR) | 120 |
| SPIx Master Mode (Half-Duplex, Transmit Only, CKE = 1) | 390 | U | |
| SPIx Slave Mode (Full-Duplex, CKE = 0, CKP = 0, SMP = 0) | 400 | Universal Asynchronous Receiver Transmitter (UART) | 275 |
| SPIx Slave Mode (Full-Duplex, CKE = 0, CKP = 1, SMP = 0) | 398 | V | |
| SPIx Slave Mode (Full-Duplex, CKE = 1, CKP = 0, SMP = 0) | 394 | Voltage Regulator (On-Chip) | 349 |
| SPIx Slave Mode (Full-Duplex, CKE = 1, CKP = 1, SMP = 0) | 396 | W | |
| Timer1/2/3 External Clock..... | 385 | Watchdog Timer (WDT)..... | 345, 349 |
| TimerQ (QEI Module) External Clock | 411 | Programming Considerations | 350 |
| Timing Requirements | | Watchdog Timer Time-out Reset (WDTO) | 120 |
| 10-Bit, High-Speed ADC | 407 | WWW Address | 451 |
| Auxiliary PLL Clock Specifications..... | 380 | WWW, On-Line Support | 14 |
| Capacitive Loading Requirements on Output Pins | 378 | | |
| DMA Read/Write | 412 | | |
| ECAN I/O | 412 | | |
| External Clock..... | 379 | | |
| High-Speed PWMx | 389 | | |
| I/O | 382 | | |
| I2Cx Bus Data (Master Mode) | 403 | | |
| I2Cx Bus Data (Slave Mode) | 405 | | |
| Input Capture x (ICx)..... | 387 | | |
| Output Compare x (OCx) | 387 | | |
| PLL Clock Specifications | 380 | | |
| QEI External Clock..... | 411 | | |
| QEI Index Pulse | 411 | | |
| Quadrature Decoder | 410 | | |
| Reset, Watchdog Timer, Oscillator Start-up Timer, Power-up Timer and Brown-out Reset..... | 384 | | |
| Simple OCx/PWMx Mode | 388 | | |
| SPIx Master Mode (Full-Duplex, CKE = 0, CKP = x, SMP = 1)..... | 393 | | |
| SPIx Master Mode (Full-Duplex, CKE = 1, CKP = x, SMP = 1)..... | 392 | | |
| SPIx Master Mode (Half-Duplex, Transmit Only)..... | 391 | | |
| SPIx Slave Mode (Full-Duplex, CKE = 0, CKP = 0, SMP = 0) | 401 | | |
| SPIx Slave Mode (Full-Duplex, CKE = 0, CKP = 1, SMP = 0) | 399 | | |
| SPIx Slave Mode (Full-Duplex, CKE = 1, CKP = 0, SMP = 0) | 395 | | |
| SPIx Slave Mode (Full-Duplex, CKE = 1, CKP = 1, SMP = 0) | 397 | | |
| Timer1 External Clock..... | 385 | | |
| Timer2/4 External Clock..... | 386 | | |
| Timer3/5 External Clock..... | 386 | | |

THE MICROCHIP WEB SITE

Microchip provides online support via our WWW site at www.microchip.com. This web site is used as a means to make files and information easily available to customers. Accessible by using your favorite Internet browser, the web site contains the following information:

- **Product Support** – Data sheets and errata, application notes and sample programs, design resources, user's guides and hardware support documents, latest software releases and archived software
- **General Technical Support** – Frequently Asked Questions (FAQs), technical support requests, online discussion groups, Microchip consultant program member listing
- **Business of Microchip** – Product selector and ordering guides, latest Microchip press releases, listing of seminars and events, listings of Microchip sales offices, distributors and factory representatives

CUSTOMER CHANGE NOTIFICATION SERVICE

Microchip's customer notification service helps keep customers current on Microchip products. Subscribers will receive e-mail notification whenever there are changes, updates, revisions or errata related to a specified product family or development tool of interest.

To register, access the Microchip web site at www.microchip.com. Under "Support", click on "Customer Change Notification" and follow the registration instructions.

CUSTOMER SUPPORT

Users of Microchip products can receive assistance through several channels:

- Distributor or Representative
- Local Sales Office
- Field Application Engineer (FAE)
- Technical Support
- Development Systems Information Line

Customers should contact their distributor, representative or field application engineer (FAE) for support. Local sales offices are also available to help customers. A listing of sales offices and locations is included in the back of this document.

Technical support is available through the web site at: <http://microchip.com/support>

READER RESPONSE

It is our intention to provide you with the best documentation possible to ensure successful use of your Microchip product. If you wish to provide your comments on organization, clarity, subject matter, and ways in which our documentation can better serve you, please FAX your comments to the Technical Publications Manager at (480) 792-4150.

Please list the following information, and use this outline to provide us with your comments about this document.

TO: Technical Publications Manager Total Pages Sent _____

RE: Reader Response

From: Name _____

Company _____

Address _____

City / State / ZIP / Country _____

Telephone: (_____) _____ - _____ FAX: (_____) _____ - _____

Application (optional):

Would you like a reply? Y N

Device: dsPIC33FJ32GS406/606/608/610 and
dsPIC33FJ64GS406/606/608/610

Literature Number: DS70591E

Questions:

1. What are the best features of this document?

2. How does this document meet your hardware and software development needs?

3. Do you find the organization of this document easy to follow? If not, why?

4. What additions to the document do you think would enhance the structure and subject?

5. What deletions from the document could be made without affecting the overall usefulness?

6. Is there any incorrect or misleading information (what and where)?

7. How would you improve this document?

PRODUCT IDENTIFICATION SYSTEM

To order or obtain information, e.g., on pricing or delivery, refer to the factory or the listed sales office.

| | | | | | | | | | | | | | | | | | | | | | | | | | | | | | | | | | | | | | | | | | | | | | | | | | | | | | | | | | | | | | |
|---|--|----------------------|--|---|----------------------------------|-----------------------------|----|---|----------------------------|-----------------------|-----|---|--|--|-----|---|--|-------------------|----|---|--------|--|----|---|--------|--|----|---|---------|---------------|----|---|---------|--|--|---|--|---------------------------|---|---|-----------------------------|--|---|---|----------------------------|-----------------|----|---|---|--|----|---|---|--|----|---|---|--|----|---|--|
| <p style="text-align: center;">dsPIC 33 FJ 32 GS4 06 T - 50 I / PT - XXX</p> <p>Microchip Trademark _____</p> <p>Architecture _____</p> <p>Flash Memory Family _____</p> <p>Program Memory Size (KB) _____</p> <p>Product Group _____</p> <p>Pin Count _____</p> <p>Tape and Reel Flag (if applicable) _____</p> <p>Speed _____</p> <p>Temperature Range _____</p> <p>Package _____</p> <p>Pattern _____</p> | <p>Examples:</p> <p>a) dsPIC33FJ32GS406-50I/PT: SMPS dsPIC33, 32-Kbyte program memory, 64-pin, 50 MIPS, Industrial temp., TQFP package.</p> | | | | | | | | | | | | | | | | | | | | | | | | | | | | | | | | | | | | | | | | | | | | | | | | | | | | | | | | | | | | |
| <table border="1" style="width: 100%; border-collapse: collapse;"> <tr> <td style="width: 20%;">Architecture:</td> <td style="width: 10%;">33</td> <td style="width: 10%;">=</td> <td>16-Bit Digital Signal Controller</td> </tr> <tr> <td>Flash Memory Family:</td> <td>FJ</td> <td>=</td> <td>Flash program memory, 3.3V</td> </tr> <tr> <td>Product Group:</td> <td>GS4</td> <td>=</td> <td>Switch Mode Power Supply (SMPS) family</td> </tr> <tr> <td></td> <td>GS6</td> <td>=</td> <td>Switch Mode Power Supply (SMPS) family</td> </tr> <tr> <td>Pin Count:</td> <td>06</td> <td>=</td> <td>64-pin</td> </tr> <tr> <td></td> <td>08</td> <td>=</td> <td>80-pin</td> </tr> <tr> <td></td> <td>10</td> <td>=</td> <td>100-pin</td> </tr> <tr> <td>Speed:</td> <td>50</td> <td>=</td> <td>50 MIPS</td> </tr> <tr> <td></td> <td></td> <td>=</td> <td>40 MIPS (marking intentionally absent)</td> </tr> <tr> <td>Temperature Range:</td> <td>I</td> <td>=</td> <td>-40°C to +85°C (Industrial)</td> </tr> <tr> <td></td> <td>E</td> <td>=</td> <td>-40°C to +125°C (Extended)</td> </tr> <tr> <td>Package:</td> <td>PT</td> <td>=</td> <td>Plastic Thin Quad Flatpack - 10x10x1 mm body (TQFP)</td> </tr> <tr> <td></td> <td>PT</td> <td>=</td> <td>Plastic Thin Quad Flatpack - 12x12x1 mm body (TQFP)</td> </tr> <tr> <td></td> <td>PF</td> <td>=</td> <td>Plastic Thin Quad Flatpack - 14x14x1 mm body (TQFP)</td> </tr> <tr> <td></td> <td>MR</td> <td>=</td> <td>Plastic Quad Flat, No Lead Package - 9x9x0.9 mm body (QFN)</td> </tr> </table> | | Architecture: | 33 | = | 16-Bit Digital Signal Controller | Flash Memory Family: | FJ | = | Flash program memory, 3.3V | Product Group: | GS4 | = | Switch Mode Power Supply (SMPS) family | | GS6 | = | Switch Mode Power Supply (SMPS) family | Pin Count: | 06 | = | 64-pin | | 08 | = | 80-pin | | 10 | = | 100-pin | Speed: | 50 | = | 50 MIPS | | | = | 40 MIPS (marking intentionally absent) | Temperature Range: | I | = | -40°C to +85°C (Industrial) | | E | = | -40°C to +125°C (Extended) | Package: | PT | = | Plastic Thin Quad Flatpack - 10x10x1 mm body (TQFP) | | PT | = | Plastic Thin Quad Flatpack - 12x12x1 mm body (TQFP) | | PF | = | Plastic Thin Quad Flatpack - 14x14x1 mm body (TQFP) | | MR | = | Plastic Quad Flat, No Lead Package - 9x9x0.9 mm body (QFN) |
| Architecture: | 33 | = | 16-Bit Digital Signal Controller | | | | | | | | | | | | | | | | | | | | | | | | | | | | | | | | | | | | | | | | | | | | | | | | | | | | | | | | | | |
| Flash Memory Family: | FJ | = | Flash program memory, 3.3V | | | | | | | | | | | | | | | | | | | | | | | | | | | | | | | | | | | | | | | | | | | | | | | | | | | | | | | | | | |
| Product Group: | GS4 | = | Switch Mode Power Supply (SMPS) family | | | | | | | | | | | | | | | | | | | | | | | | | | | | | | | | | | | | | | | | | | | | | | | | | | | | | | | | | | |
| | GS6 | = | Switch Mode Power Supply (SMPS) family | | | | | | | | | | | | | | | | | | | | | | | | | | | | | | | | | | | | | | | | | | | | | | | | | | | | | | | | | | |
| Pin Count: | 06 | = | 64-pin | | | | | | | | | | | | | | | | | | | | | | | | | | | | | | | | | | | | | | | | | | | | | | | | | | | | | | | | | | |
| | 08 | = | 80-pin | | | | | | | | | | | | | | | | | | | | | | | | | | | | | | | | | | | | | | | | | | | | | | | | | | | | | | | | | | |
| | 10 | = | 100-pin | | | | | | | | | | | | | | | | | | | | | | | | | | | | | | | | | | | | | | | | | | | | | | | | | | | | | | | | | | |
| Speed: | 50 | = | 50 MIPS | | | | | | | | | | | | | | | | | | | | | | | | | | | | | | | | | | | | | | | | | | | | | | | | | | | | | | | | | | |
| | | = | 40 MIPS (marking intentionally absent) | | | | | | | | | | | | | | | | | | | | | | | | | | | | | | | | | | | | | | | | | | | | | | | | | | | | | | | | | | |
| Temperature Range: | I | = | -40°C to +85°C (Industrial) | | | | | | | | | | | | | | | | | | | | | | | | | | | | | | | | | | | | | | | | | | | | | | | | | | | | | | | | | | |
| | E | = | -40°C to +125°C (Extended) | | | | | | | | | | | | | | | | | | | | | | | | | | | | | | | | | | | | | | | | | | | | | | | | | | | | | | | | | | |
| Package: | PT | = | Plastic Thin Quad Flatpack - 10x10x1 mm body (TQFP) | | | | | | | | | | | | | | | | | | | | | | | | | | | | | | | | | | | | | | | | | | | | | | | | | | | | | | | | | | |
| | PT | = | Plastic Thin Quad Flatpack - 12x12x1 mm body (TQFP) | | | | | | | | | | | | | | | | | | | | | | | | | | | | | | | | | | | | | | | | | | | | | | | | | | | | | | | | | | |
| | PF | = | Plastic Thin Quad Flatpack - 14x14x1 mm body (TQFP) | | | | | | | | | | | | | | | | | | | | | | | | | | | | | | | | | | | | | | | | | | | | | | | | | | | | | | | | | | |
| | MR | = | Plastic Quad Flat, No Lead Package - 9x9x0.9 mm body (QFN) | | | | | | | | | | | | | | | | | | | | | | | | | | | | | | | | | | | | | | | | | | | | | | | | | | | | | | | | | | |

NOTES:

Note the following details of the code protection feature on Microchip devices:

- Microchip products meet the specification contained in their particular Microchip Data Sheet.
- Microchip believes that its family of products is one of the most secure families of its kind on the market today, when used in the intended manner and under normal conditions.
- There are dishonest and possibly illegal methods used to breach the code protection feature. All of these methods, to our knowledge, require using the Microchip products in a manner outside the operating specifications contained in Microchip's Data Sheets. Most likely, the person doing so is engaged in theft of intellectual property.
- Microchip is willing to work with the customer who is concerned about the integrity of their code.
- Neither Microchip nor any other semiconductor manufacturer can guarantee the security of their code. Code protection does not mean that we are guaranteeing the product as “unbreakable.”

Code protection is constantly evolving. We at Microchip are committed to continuously improving the code protection features of our products. Attempts to break Microchip's code protection feature may be a violation of the Digital Millennium Copyright Act. If such acts allow unauthorized access to your software or other copyrighted work, you may have a right to sue for relief under that Act.

Information contained in this publication regarding device applications and the like is provided only for your convenience and may be superseded by updates. It is your responsibility to ensure that your application meets with your specifications. MICROCHIP MAKES NO REPRESENTATIONS OR WARRANTIES OF ANY KIND WHETHER EXPRESS OR IMPLIED, WRITTEN OR ORAL, STATUTORY OR OTHERWISE, RELATED TO THE INFORMATION, INCLUDING BUT NOT LIMITED TO ITS CONDITION, QUALITY, PERFORMANCE, MERCHANTABILITY OR FITNESS FOR PURPOSE. Microchip disclaims all liability arising from this information and its use. Use of Microchip devices in life support and/or safety applications is entirely at the buyer's risk, and the buyer agrees to defend, indemnify and hold harmless Microchip from any and all damages, claims, suits, or expenses resulting from such use. No licenses are conveyed, implicitly or otherwise, under any Microchip intellectual property rights.

Trademarks

The Microchip name and logo, the Microchip logo, dsPIC, FlashFlex, KEELOQ, KEELOQ logo, MPLAB, PIC, PICmicro, PICSTART, PIC³² logo, rPIC, SST, SST Logo, SuperFlash and UNI/O are registered trademarks of Microchip Technology Incorporated in the U.S.A. and other countries.

FilterLab, Hampshire, HI-TECH C, Linear Active Thermistor, MTP, SEEVAL and The Embedded Control Solutions Company are registered trademarks of Microchip Technology Incorporated in the U.S.A.

Silicon Storage Technology is a registered trademark of Microchip Technology Inc. in other countries.

Analog-for-the-Digital Age, Application Maestro, BodyCom, chipKIT, chipKIT logo, CodeGuard, dsPICDEM, dsPICDEM.net, dsPICworks, dsSPEAK, ECAN, ECONOMONITOR, FanSense, HI-TIDE, In-Circuit Serial Programming, ICSP, Mindi, MiWi, MPASM, MPF, MPLAB Certified logo, MPLIB, MPLINK, mTouch, Omniscient Code Generation, PICC, PICC-18, PICDEM, PICDEM.net, PICkit, PICTail, REAL ICE, rLAB, Select Mode, SQI, Serial Quad I/O, Total Endurance, TSHARC, UniWinDriver, WiperLock, ZENA and Z-Scale are trademarks of Microchip Technology Incorporated in the U.S.A. and other countries.

SQTP is a service mark of Microchip Technology Incorporated in the U.S.A.

GestIC and ULPP are registered trademarks of Microchip Technology Germany II GmbH & Co. & KG, a subsidiary of Microchip Technology Inc., in other countries.

All other trademarks mentioned herein are property of their respective companies.

© 2012, Microchip Technology Incorporated, Printed in the U.S.A., All Rights Reserved.

 Printed on recycled paper.

ISBN: 978-1-62076-650-7

QUALITY MANAGEMENT SYSTEM
CERTIFIED BY DNV
== ISO/TS 16949 ==

Microchip received ISO/TS-16949:2009 certification for its worldwide headquarters, design and wafer fabrication facilities in Chandler and Tempe, Arizona; Gresham, Oregon and design centers in California and India. The Company's quality system processes and procedures are for its PIC[®] MCUs and dsPIC[®] DSCs, KEELOQ[®] code hopping devices, Serial EEPROMs, microperipherals, nonvolatile memory and analog products. In addition, Microchip's quality system for the design and manufacture of development systems is ISO 9001:2000 certified.



MICROCHIP

Worldwide Sales and Service

AMERICAS

Corporate Office
2355 West Chandler Blvd.
Chandler, AZ 85224-6199
Tel: 480-792-7200
Fax: 480-792-7277
Technical Support:
<http://www.microchip.com/support>
Web Address:
www.microchip.com

Atlanta
Duluth, GA
Tel: 678-957-9614
Fax: 678-957-1455

Boston
Westborough, MA
Tel: 774-760-0087
Fax: 774-760-0088

Chicago
Itasca, IL
Tel: 630-285-0071
Fax: 630-285-0075

Cleveland
Independence, OH
Tel: 216-447-0464
Fax: 216-447-0643

Dallas
Addison, TX
Tel: 972-818-7423
Fax: 972-818-2924

Detroit
Farmington Hills, MI
Tel: 248-538-2250
Fax: 248-538-2260

Indianapolis
Noblesville, IN
Tel: 317-773-8323
Fax: 317-773-5453

Los Angeles
Mission Viejo, CA
Tel: 949-462-9523
Fax: 949-462-9608

Santa Clara
Santa Clara, CA
Tel: 408-961-6444
Fax: 408-961-6445

Toronto
Mississauga, Ontario,
Canada
Tel: 905-673-0699
Fax: 905-673-6509

ASIA/PACIFIC

Asia Pacific Office
Suites 3707-14, 37th Floor
Tower 6, The Gateway
Harbour City, Kowloon
Hong Kong
Tel: 852-2401-1200
Fax: 852-2401-3431

Australia - Sydney
Tel: 61-2-9868-6733
Fax: 61-2-9868-6755

China - Beijing
Tel: 86-10-8569-7000
Fax: 86-10-8528-2104

China - Chengdu
Tel: 86-28-8665-5511
Fax: 86-28-8665-7889

China - Chongqing
Tel: 86-23-8980-9588
Fax: 86-23-8980-9500

China - Hangzhou
Tel: 86-571-2819-3187
Fax: 86-571-2819-3189

China - Hong Kong SAR
Tel: 852-2401-1200
Fax: 852-2401-3431

China - Nanjing
Tel: 86-25-8473-2460
Fax: 86-25-8473-2470

China - Qingdao
Tel: 86-532-8502-7355
Fax: 86-532-8502-7205

China - Shanghai
Tel: 86-21-5407-5533
Fax: 86-21-5407-5066

China - Shenyang
Tel: 86-24-2334-2829
Fax: 86-24-2334-2393

China - Shenzhen
Tel: 86-755-8203-2660
Fax: 86-755-8203-1760

China - Wuhan
Tel: 86-27-5980-5300
Fax: 86-27-5980-5118

China - Xian
Tel: 86-29-8833-7252
Fax: 86-29-8833-7256

China - Xiamen
Tel: 86-592-2388138
Fax: 86-592-2388130

China - Zhuhai
Tel: 86-756-3210040
Fax: 86-756-3210049

ASIA/PACIFIC

India - Bangalore
Tel: 91-80-3090-4444
Fax: 91-80-3090-4123

India - New Delhi
Tel: 91-11-4160-8631
Fax: 91-11-4160-8632

India - Pune
Tel: 91-20-2566-1512
Fax: 91-20-2566-1513

Japan - Osaka
Tel: 81-66-152-7160
Fax: 81-66-152-9310

Japan - Yokohama
Tel: 81-45-471-6166
Fax: 81-45-471-6122

Korea - Daegu
Tel: 82-53-744-4301
Fax: 82-53-744-4302

Korea - Seoul
Tel: 82-2-554-7200
Fax: 82-2-558-5932 or
82-2-558-5934

Malaysia - Kuala Lumpur
Tel: 60-3-6201-9857
Fax: 60-3-6201-9859

Malaysia - Penang
Tel: 60-4-227-8870
Fax: 60-4-227-4068

Philippines - Manila
Tel: 63-2-634-9065
Fax: 63-2-634-9069

Singapore
Tel: 65-6334-8870
Fax: 65-6334-8850

Taiwan - Hsin Chu
Tel: 886-3-5778-366
Fax: 886-3-5770-955

Taiwan - Kaohsiung
Tel: 886-7-536-4818
Fax: 886-7-330-9305

Taiwan - Taipei
Tel: 886-2-2500-6610
Fax: 886-2-2508-0102

Thailand - Bangkok
Tel: 66-2-694-1351
Fax: 66-2-694-1350

EUROPE

Austria - Wels
Tel: 43-7242-2244-39
Fax: 43-7242-2244-393

Denmark - Copenhagen
Tel: 45-4450-2828
Fax: 45-4485-2829

France - Paris
Tel: 33-1-69-53-63-20
Fax: 33-1-69-30-90-79

Germany - Munich
Tel: 49-89-627-144-0
Fax: 49-89-627-144-44

Italy - Milan
Tel: 39-0331-742611
Fax: 39-0331-466781

Netherlands - Drunen
Tel: 31-416-690399
Fax: 31-416-690340

Spain - Madrid
Tel: 34-91-708-08-90
Fax: 34-91-708-08-91

UK - Wokingham
Tel: 44-118-921-5869
Fax: 44-118-921-5820

11/29/11



Компания «ЭлектроПласт» предлагает заключение долгосрочных отношений при поставках импортных электронных компонентов на взаимовыгодных условиях!

Наши преимущества:

- Оперативные поставки широкого спектра электронных компонентов отечественного и импортного производства напрямую от производителей и с крупнейших мировых складов;
- Поставка более 17-ти миллионов наименований электронных компонентов;
- Поставка сложных, дефицитных, либо снятых с производства позиций;
- Оперативные сроки поставки под заказ (от 5 рабочих дней);
- Экспресс доставка в любую точку России;
- Техническая поддержка проекта, помощь в подборе аналогов, поставка прототипов;
- Система менеджмента качества сертифицирована по Международному стандарту ISO 9001;
- Лицензия ФСБ на осуществление работ с использованием сведений, составляющих государственную тайну;
- Поставка специализированных компонентов (Xilinx, Altera, Analog Devices, Intersil, Interpoint, Microsemi, Aeroflex, Peregrine, Syfer, Eurofarad, Texas Instrument, Miteq, Cobham, E2V, MA-COM, Hittite, Mini-Circuits, General Dynamics и др.);

Помимо этого, одним из направлений компании «ЭлектроПласт» является направление «Источники питания». Мы предлагаем Вам помощь Конструкторского отдела:

- Подбор оптимального решения, техническое обоснование при выборе компонента;
- Подбор аналогов;
- Консультации по применению компонента;
- Поставка образцов и прототипов;
- Техническая поддержка проекта;
- Защита от снятия компонента с производства.



Как с нами связаться

Телефон: 8 (812) 309 58 32 (многоканальный)

Факс: 8 (812) 320-02-42

Электронная почта: org@eplast1.ru

Адрес: 198099, г. Санкт-Петербург, ул. Калинина, дом 2, корпус 4, литера А.