

RK168 Rotary Motor-driven Type

Remote controllable and available in a wide variety of products

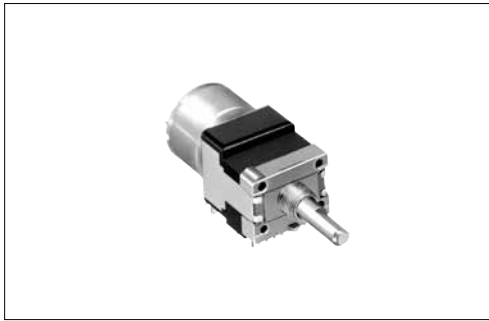

Typical Specifications



Items	Specifications
Total resistance tolerance	±20%
Maximum operating voltage	50V AC
Total rotational angle	300° ±5°
Rotational torque	10 to 40mN·m
Operating life	15,000 cycles
Operating temperature range	-10°C to +70°C
Motor voltage	4 to 6V DC (Standard: 4.5VDC)
Potentiometer rotational speed (sec/300°)	12±3 (4.5V DC)
Maximum operating current	At rotation: 100mA / At end slip: 150mA

Product Line

Number of resistor elements	Mounting direction	Shaft type	Length of the shaft L ₁ (mm)	Total resistance (kΩ)	Resistance taper	Motor print terminal	Minimum order unit (pcs.)		Products No.	Drawing No.
							Japan	Export		
Dual-unit	Horizontal type	Flat	25	100	3B	With	200	200	RK16812MG099	1
				10		Without			RK16812MG09T	2
Quad-unit				100	15A				RK16814MGA0K	3

Note

Other varieties are also available. Refer to "Other Specifications" (P.340, 341).

Packing Specifications

Tray

Number of packages (pcs.)		Export package measurements (mm)
1 case /Japan	1 case /export packing	
200	200	527×368×215

Dimensions

Unit:mm

No.	Photo	Style	PC board mounting hole dimensions (Viewed from mounting side)
1	<p>16mm size Single-shaft, dual-unit RK16812MG</p>	<p>Shaft shown in full CCW position</p>	
2	<p>16mm size Single-shaft, dual-unit RK16812MG</p>	<p>Shaft shown in full CCW position</p>	

Refer to P.340 for other specifications.
 Refer to P.341 for attached parts.
 Refer to P.342 for ordering products not listed.
 Refer to P.343 for soldering conditions.

Rotary Potentiometers
 Slide Potentiometers
 Metal Shaft
 Insulated Shaft
 Knob Operating
 Through Shaft Type
 Ring Type

RK168 Rotary Motor-driven Type

Dimensions

Unit:mm

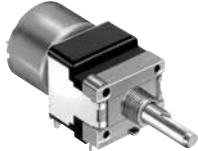
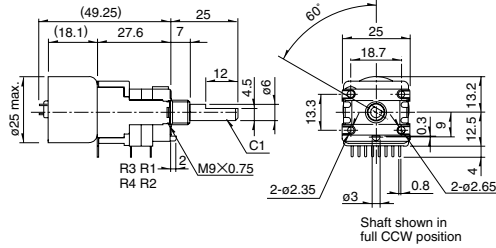
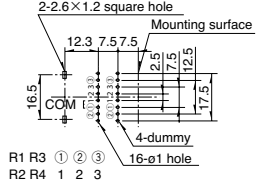
No.	Photo	Style	PC board mounting hole dimensions (Viewed from mounting side)
3	 <p>16mm size Single-shaft, quad.-unit RK16814MG</p>	 <p>Shaft shown in full CCW position</p>	 <p>2-2.6×1.2 square hole Mounting surface COM R1 R3 ① ② ③ R2 R4 1 2 3 4-dummy 16-φ1 hole</p>

Terminal Layout / Circuit Diagram

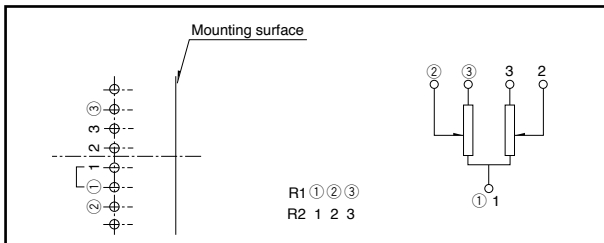

Rotary Motor-driven Type / Other Specifications

In addition to the products listed, we can accommodate the follow specifications.

Basic Motor Specifications

Number of unit	Model	Motor type		Motor voltage	Potentiometer rotational speed	Max. operating current
		Sealed case	Motor printed terminal			
Single-shaft, dual-unit	RK16812MG	Available	Available	4 to 6V DC (Standard: 4.5)	12±3sec./300° (4.5V DC)	At rotation 100mA At end slip 150mA (4.5V DC)
Single-shaft, quad-unit	RK16814MG					

Total Resistance Variety

Total resistance (kΩ)	10	20	50	100

Resistance Taper

Resistance taper	15A	3B

Rotary Motor-driven Type / Other Specifications

Shaft Variety

Unit:mm

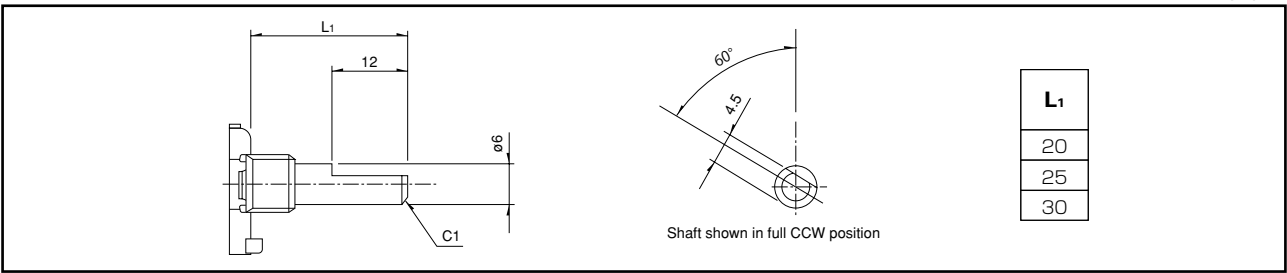

Standard Dimensions of Bushing and Fixing Lug

Unit:mm

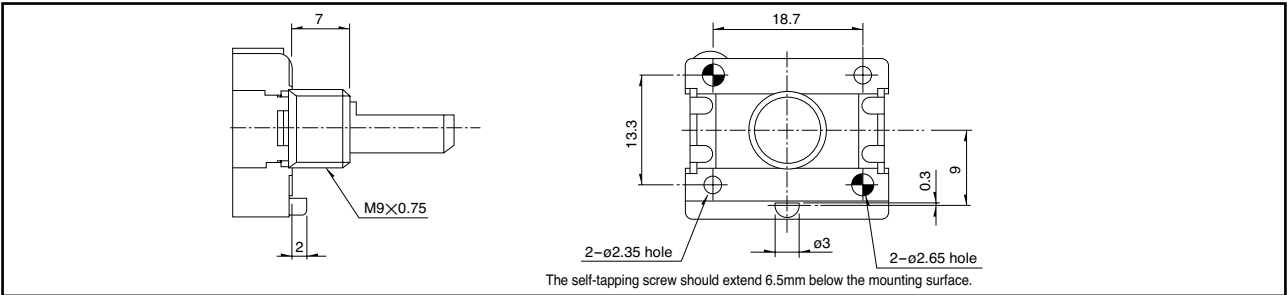

Style of Printed Terminal for Motor

Unit:mm

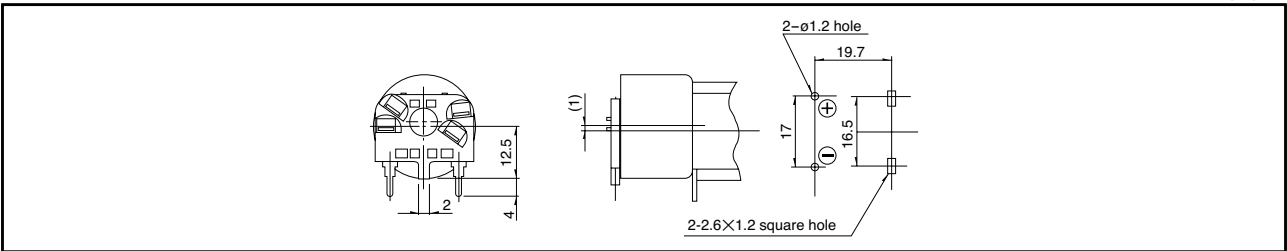

Note

Marked are specifications recommended by Alps Alpine.

Rotary Motor-driven Type / Attached Parts

The following parts are included with the product.

Unit:mm

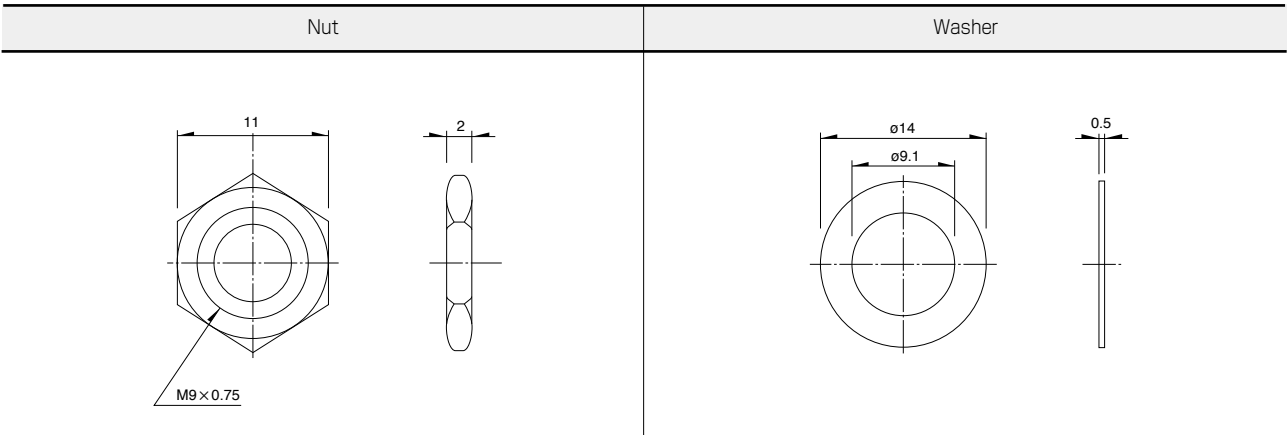

Rotary Motor-driven Type / Ordering Products Not Listed

When ordering product varieties that are not listed, specify referring to the examples below.

Sample Part Number

R K 1 6 8 1 2 M G - **F 2 0** - **B 1 0 3** - **M 0**

Model type

Code	Model type
12	Single-shaft, dual-unit
14	Single-shaft, quad-unit

Shaft type

Code	Shaft type
F	Flat

※ Flat shaft only

Length of the shaft L₁ (mm)

Code	Length of the shaft
20	20
25	25
30	30

Resistance taper

Code	Resistance taper
A	15A
V	3B

※ 1B can be accommodated on request. Please inquire.

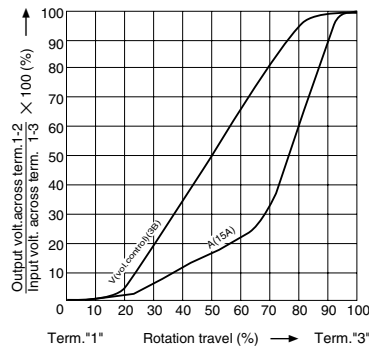

Total resistance

Code	Total resistance (k Ω)
10	103
20	203
50	503
100	104

Printed terminal for motor

Code	Printed terminal for motor
M0	without
M1	with

Note

Marked are specifications recommended by Alps Alpine.

Rotary Potentiometers

Slide Potentiometers











Metal Shaft

Insulated Shaft

Knob Operating

Through Shaft Type

Ring Type

Type	16mm size	20mm size	27mm size	50mm size	Rotary motor-driven	
Series	RK163	RK203	RK271	RK501	RK168	
	Single-shaft					
Number of resistor elements	Single/dual	Single	Single/dual/quad	Dual/quad	Dual/quad/5-ganged/6-ganged	
Photo						
Terminal mounting	Horizontal	Vertical	Horizontal			
Fixing method of bushing	Bushing screw clamp					
Operating temperature range	-10°C to +70°C	-40°C to +85°C	-10°C to +70°C			
Operating life	15,000 cycles	30,000 cycles	15,000 cycles			
Available for automotive use	—	○	—	—	—	
Life cycle (availability)						
Electrical performance	Total resistance (kΩ)	5, 10, 20, 50, 100, 200	10	5, 10, 20, 50, 100, 250	10, 20, 50, 100	
	Resistance taper	15A, 1B, 3B, 15C	B	15A, 3B		
	Rated Power	0.1W 0.05W (15A)	0.05W		0.1W	0.05W
	Residual resistance	R≤10kΩ 20Ω max. 10kΩ<R≤50kΩ 30Ω max. 50kΩ<R<3MΩ Nominal total resistance of 0.1% or less%	—	R≤10kΩ 20Ω max. 10kΩ<R<50kΩ 30Ω max. 50kΩ≤R Nominal total resistance of 0.1% or less%	—	—
	Maximum attenuation (Volume control)	5kΩ≤R<10kΩ 70dB min. 10kΩ≤R<50kΩ 80dB min. 50kΩ≤R<100kΩ 90dB min. 100kΩ≤R 100dB min.	—	5kΩ≤R<10kΩ 70dB min. 10kΩ≤R<50kΩ 80dB min. 50kΩ≤R<100kΩ 90dB min. 100kΩ≤R 100dB min.	120dB min.	5kΩ≤R<10kΩ 70dB min. 10kΩ≤R<50kΩ 80dB min. 50kΩ≤R<100kΩ 90dB min. 100kΩ≤R 100dB min.
	Gang error applicable to Dual-unit parts for audio volume control purposes	-40dB to 0dB 3dB max.	—	-70dB to -60dB 3dB max. -60dB to 0dB 2dB max.	-100dB to 0dB 2dB max.	-60dB to -40dB 5dB max. -40dB to 0dB 3dB max.
	Insulation resistance	100MΩ min. 500V DC	10MΩ min. 250V DC	100MΩ min. 500V DC		100MΩ min. 250V DC
	Voltage proof	500V AC for 1minute	300V AC for 1minute	500V AC for 1minute		300V AC for 1minute
	Center-taps	Without				
Mechanical performance	Detent	Without, Cente	17	Without, Center, 21, 31, 41	Without	
	Stopper strength	0.9 N·m	0.5 N·m	0.9 N·m	1.5 N·m	0.9 N·m
	Push-pull strength	100N max.			150N max.	100N max.
	Vibration	10 to 55 to 10Hz/min., the amplitude is 1.5mm for all the frequencies, in the 3 direction of X, Y and Z for 2 hours respectively				
Shaft style	Serrated type, Flat type, Slotted type	Flat type	Slotted type, Flat type	Slotted type	Flat type	
Terminal style	Insertion, Lead	Insertion				
Attached switch	—	—	—	—	—	
Page	325	330	333	337	339	

Metal Shaft Potentiometers Soldering Conditions	343
Potentiometers Cautions	418
Potentiometers Measurement and Test Methods	420
Potentiometers Resistance Taper	422

Note

○ Indicates applicability to some products in the series.

Rotary Potentiometers
 Slide Potentiometers
 Metal Shaft
 Insulated Shaft
 Knob Operating
 Through Shaft Type
 Ring Type

Reference for Manual Soldering

Series	Tip temperature	Soldering time	No. of solders
RK09L, RK097	350°C max.	3s max.	1 time
RK203	300°C max.	3s max.	1 time
RK119	350±10°C	3 ⁺¹ ₀ s	1 time
RK271	350°C max.	5s max.	1 time
RK501	350±10°C	5 ⁺¹ ₀ s	1 time
RK163	350°C max.	5s max.	1 time
RK168	Potentiometer terminal	300°C max.	3s max.
	Motor terminal	350°C max.	2s max.

Reference for Dip Soldering

Series	Preheating		Dip soldering		No. of solders
	Soldering surface temperature	Heating time	Soldering temperature	Soldering time	
RK09L, RK097, RK203	100°C max.	2 min. max.	260±5°C	5±1s	2 time max.
RK501	120±10°C	2 min. max.	260±5°C	5±1s	2 time

Example of Reflow Soldering Condition

Temperature profile

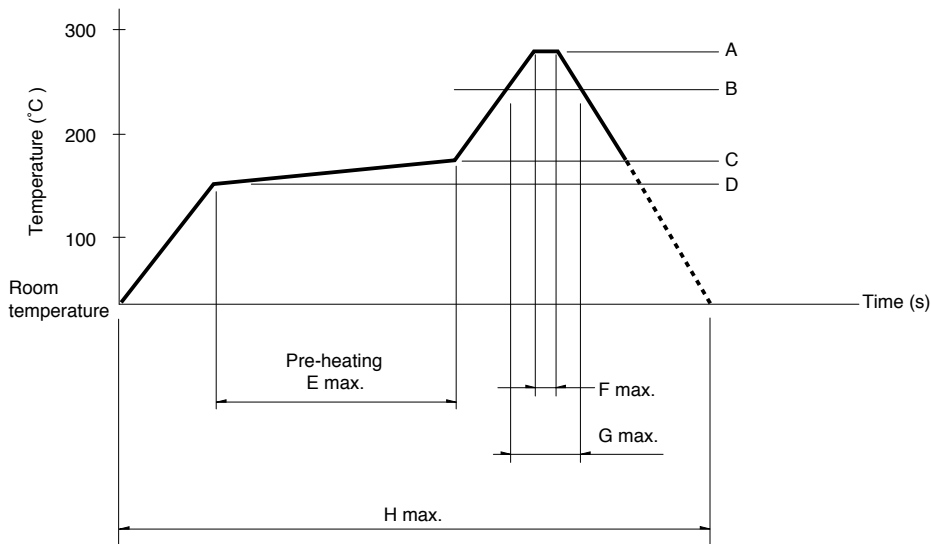

Series	A	B	C	D	E	F	G	H	No. of reflows
RK119	260°C	230°C	180°C	150°C	2 min.	3s	40s	4 min.	2 time max.

Notes

1. When using an infrared reflow oven, solder may sometimes not be applied. Be sure to use a hot air reflow oven or at type that uses infrared rays in combination with hot air.
2. The temperatures given above are the maximum temperatures at the terminals of the potentiometer when employing a hot air reflow method. The temperature of the PC board and the surface temperature of the potentiometer may vary greatly depending on the PC board material, its size and thickness. Ensure that the surface temperature of the potentiometer does not rise to 250°C or greater.
3. Conditions vary to some extent depending on the type of reflow bath used. Be sure to give due consideration to this prior to use.



Компания «ЭлектроПласт» предлагает заключение долгосрочных отношений при поставках импортных электронных компонентов на взаимовыгодных условиях!

Наши преимущества:

- Оперативные поставки широкого спектра электронных компонентов отечественного и импортного производства напрямую от производителей и с крупнейших мировых складов;
- Поставка более 17-ти миллионов наименований электронных компонентов;
- Поставка сложных, дефицитных, либо снятых с производства позиций;
- Оперативные сроки поставки под заказ (от 5 рабочих дней);
- Экспресс доставка в любую точку России;
- Техническая поддержка проекта, помощь в подборе аналогов, поставка прототипов;
- Система менеджмента качества сертифицирована по Международному стандарту ISO 9001;
- Лицензия ФСБ на осуществление работ с использованием сведений, составляющих государственную тайну;
- Поставка специализированных компонентов (Xilinx, Altera, Analog Devices, Intersil, Interpoint, Microsemi, Aeroflex, Peregrine, Syfer, Eurofarad, Texas Instrument, Miteq, Cobham, E2V, MA-COM, Hittite, Mini-Circuits, General Dynamics и др.);

Помимо этого, одним из направлений компании «ЭлектроПласт» является направление «Источники питания». Мы предлагаем Вам помощь Конструкторского отдела:

- Подбор оптимального решения, техническое обоснование при выборе компонента;
- Подбор аналогов;
- Консультации по применению компонента;
- Поставка образцов и прототипов;
- Техническая поддержка проекта;
- Защита от снятия компонента с производства.



Как с нами связаться

Телефон: 8 (812) 309 58 32 (многоканальный)

Факс: 8 (812) 320-02-42

Электронная почта: org@eplast1.ru

Адрес: 198099, г. Санкт-Петербург, ул. Калинина, дом 2, корпус 4, литера А.