

LOW POWER VIDEO AMPLIFIER WITH Y-C MIXER

■ GENERAL DESCRIPTION

The **NJM2274A** is a low voltage operation video amplifier with Y/C mixer and 75-ohm driver.

The NJM2274A is suitable for DSC, DVC, CCD camera and other portable video applications.

The NJM2274 is 0.5Vp-p input, and The NJM2274A is 1.0Vp-p input.

■ PACKAGE OUTLINE



NJM2274AR
(MSOP8 (VSP8))

■ FEATURES

- Low Operating Voltage 2.8 to 5.5V
- Y/C MIX Circuit
- 6dB Amplifier
- 75Ω Driver Circuit (2-line drive)
- Y-input: Clamp
C-input: Bias
- Bipolar Technology
- Package Outline MSOP8 (VSP8)*

*MEET JEDEC MO-187-DA

■ PIN CONFIGURATION

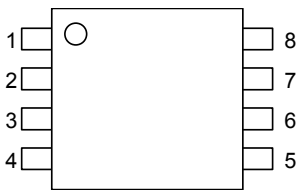

- 1: YIN
- 2: GND
- 3: VOUT
- 4: VSAG
- 5: V⁺
- 6: Power save
- 7: C mute
- 8: CIN

■ BLOCK DIAGRAM

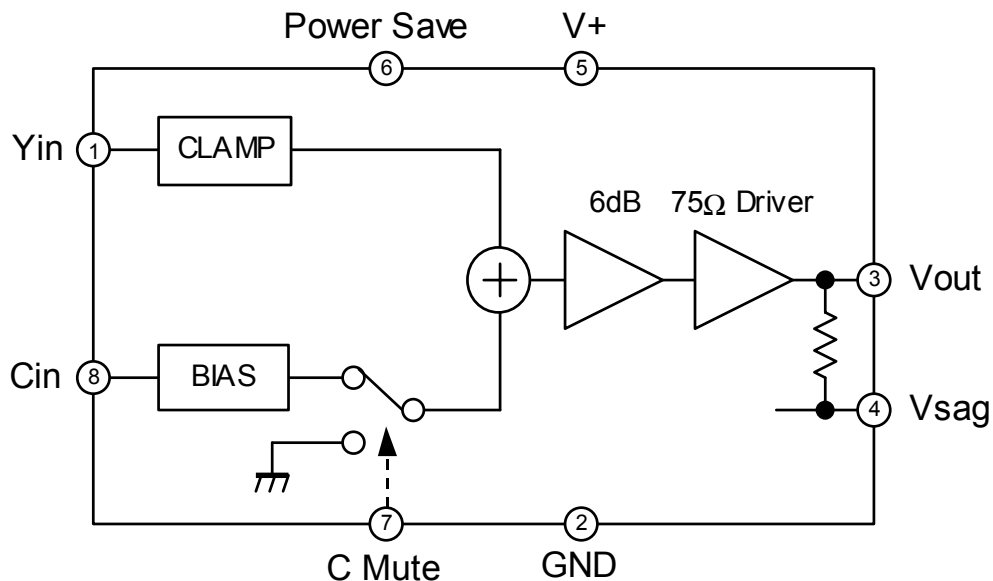

NJM2274A

■ ABOSOLUTE MAXIMUM RATINGS

(Ta=25°C)

PARAMRTER	SYMBOL	RATINGS	UNIT
Supply Voltage	V ⁺	7.0	V
Power Dissipation	P _D	580(Note1)	mW
Operating Temperature Range	Topr	-40 to +85	°C
Storage Temperature Range	Tstg	-40 to +125	°C

(Note) At on a board of EIA/JEDEC specification. (114.3 x 76.2 x 1.6mm 2 layers, FR-4)

■ RECOMMENDED OPEARATING CONDITION

(Ta=25°C)

PARAMETER	SYMBOL	TEST CONDITION	MIN.	TYP.	MAX.	UNIT
Operating Voltage	Vopr		2.8	3.0	5.5	V

■ ELECTRICAL CHARACTERISTICS (V⁺=3.0V, Ta=25°C)

PARAMETER	SYMBOL	TEST CONDITION	MIN.	TYP.	MAX.	UNIT
Operating Current	I _{cc}	No Signal	-	9.3	14.0	mA
Operating Current (Power Save Mode)	I _{save}	Power Save Mode	-	0.8	1.4	mA
Maximum Output Voltage	V _{om}	f=1kHz, THD=1%	2.2	-	-	V _{pp}
Voltage Gain	G _v	Yin=100kHz, 1.0V _{pp} , Sine Video Signal (note)	5.9	6.4	6.9	dB
Frequency Characteristic	G _f	Yin=10MHz/100kHz, 1.0V _{pp} , Sine Video Signal (note)	-1.0	0	+1.0	dB
Differential Gain	DG	Yin=1.0V _{pp} , 10Step Video Signal	-	2.5	-	%
Differential Phase	DP	Yin=1.0V _{pp} , 10Step Video Signal	-	1.0	-	deg
Chroma Mute Cross talk	CT	Cin=4.43MHz, 0.2V _{pp}	-	-65	-	dB
S/N Ratio	SN _v	Yin=0.2V _{pp} , 100%White Video Signal, Cin=AC gnd Wide Band 100kHz to 6MHz, R _L =75ohm	-	66	-	dB
Second Distortion	H _v	Yin=0.2V _{pp} , 3.58MHz Red Field Video Signal, Cin=AC gnd R _L =75ohm	-	-40	-	dB
Input Resistance	R _{cin}	Chroma signal input	-	20	-	kΩ
Mute Switch Change Voltage	V _{thMH}		1.4	-	V ⁺	V
	V _{thML}		0	-	0.6	
Power Save Switch Change Voltage	V _{thPH}		1.4	-	V ⁺	V
	V _{thPL}		0	-	0.6	

note) Sine Video Signal

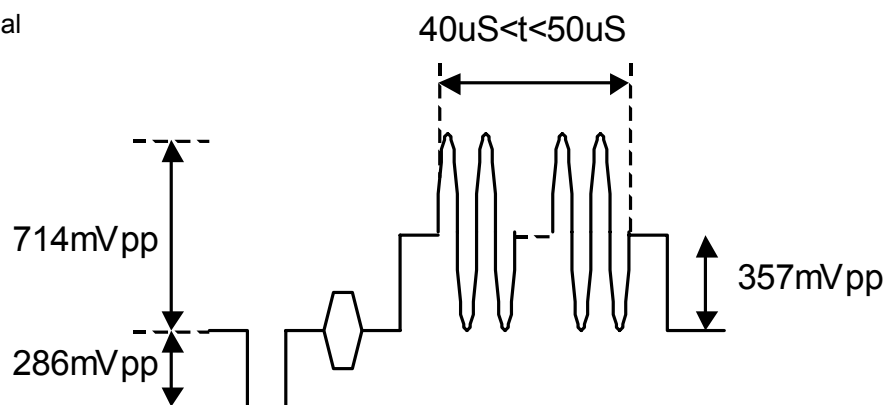

■ CONTROL TERMINAL EXPLANATION

PARAMETER	STATUS	NOTE
Chroma Mute	H	Chroma Mute: ON
	L	Chroma Mute: OFF
	OPEN	Chroma Mute: OFF
Power Save	H	Power Save: OFF (Active)
	L	Power Save: ON (Mute)
	OPEN	Power Save: ON (Mute)

■ TEST CIRCUIT

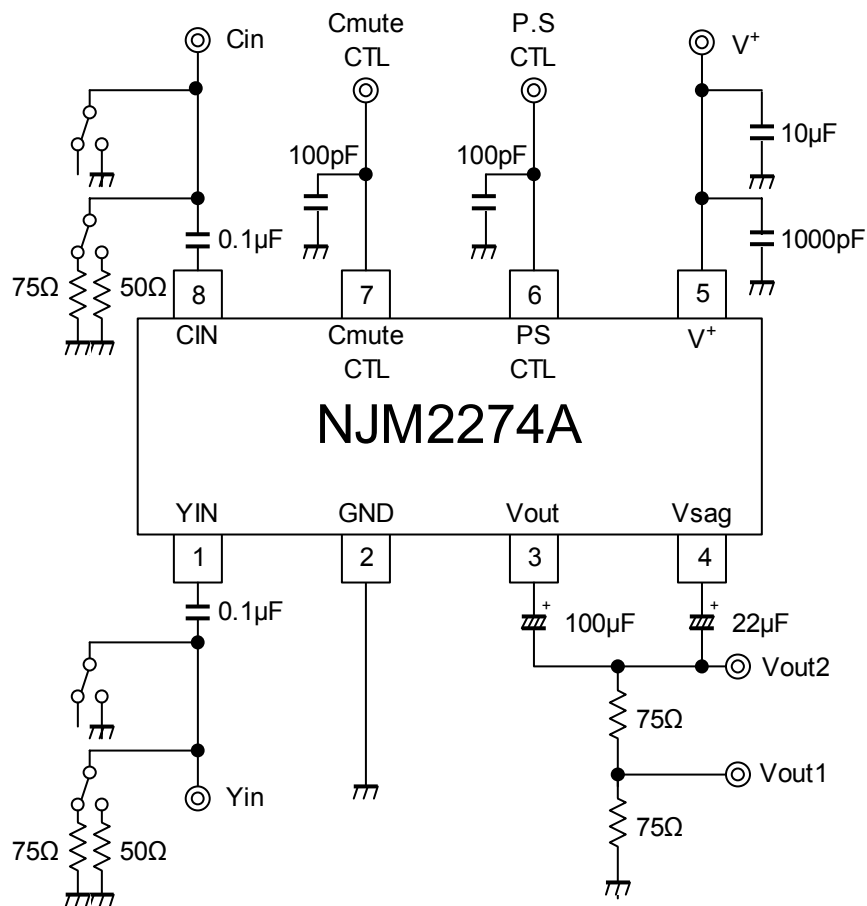

NJM2274A

APPLICATION CIRCUIT

(1) Standard circuit

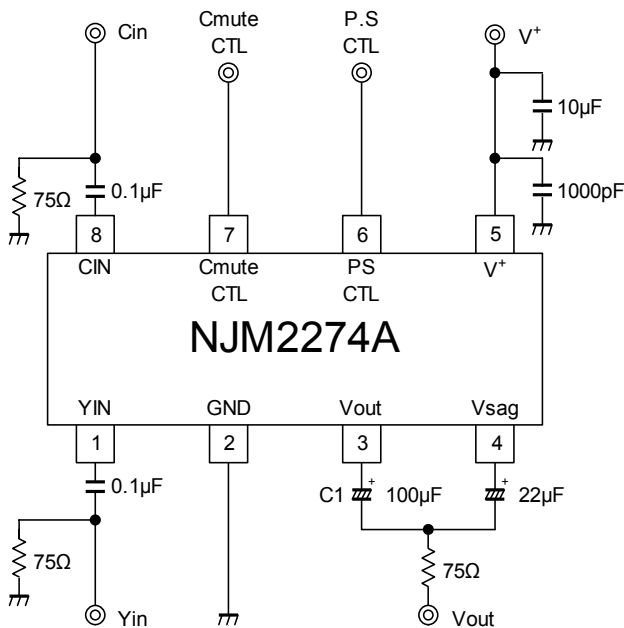

(2) SAG correction unused circuit

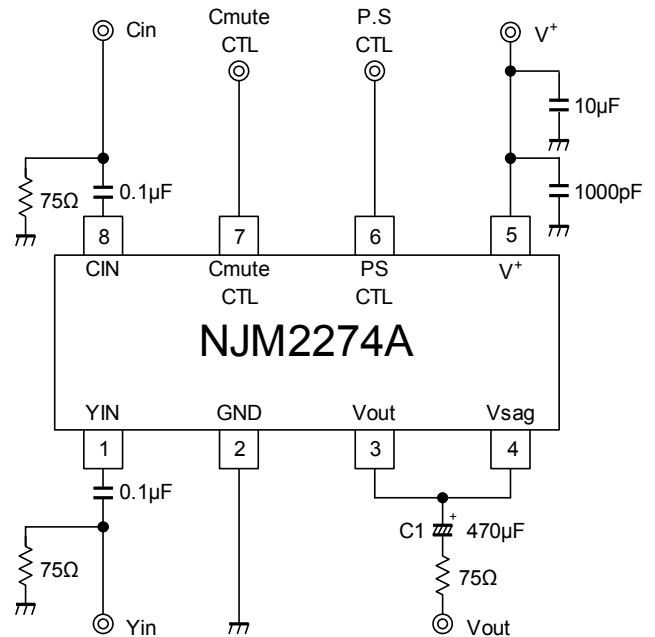

(3) Two-line driving circuit

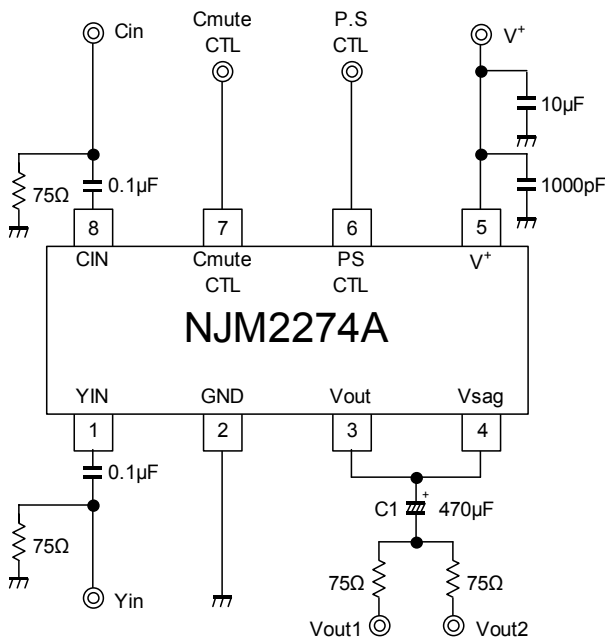

(1) Standard circuit

The SAG correction reduces output coupling capacitor values.

Adjust the C1 value, checking the waveform containing a lot of low frequency components like a bounce waveform (In case of worst condition). Change the capacitor of C1 into a large value to improve SAG.

(2) SAG correction unused circuit

Cancel the SAG correction to improve lost synchronization.

Connect the coupling capacitor after connecting the Vout pin and Vsag pin. The recommended value is 470μF or more.

(3) Two-line driving circuit

This circuit drives two-line of 150Ω. However, it may cause to lose synchronization by an input signal of large APL change (100% white signals more than 1Vp-p). Confirm the large APL change waveform (100% white signals more than 1Vp-p) and evaluate sufficiently.

■ TERMINAL DESCRIPTION

PIN No.	SYMBOL	FUNCTION	VOLTAGE	EQUIVALENT CIRCUIT
1	Yin	Luminance Signal Input	1.3V	
2	GND	GND	0V	
3	Vout	Composite Video Signal Output	0.3V	
4	Vsag	SAG Correction	0.38	

NJM2274A

PIN No.	SYMBOL	FUNCTION	VOLTAGE	EQUIVALENT CIRCUIT
5	V+	Power Supply	-	
6	Power Save CTL.	Power Save Control	0V	
7	Cmute CTL	Chroma Signal Mute Control	0V	
8	Cin	Chroma Signal Input	1.4V	

[CAUTION]
The specifications on this databook are only given for information, without any guarantee as regards either mistakes or omissions. The application circuits in this databook are described only to show representative usages of the product and not intended for the guarantee or permission of any right including the industrial rights.

Mouser Electronics

Authorized Distributor

Click to View Pricing, Inventory, Delivery & Lifecycle Information:

[NJR:](#)

[NJM2274AR-TE1](#)



Компания «ЭлектроПласт» предлагает заключение долгосрочных отношений при поставках импортных электронных компонентов на взаимовыгодных условиях!

Наши преимущества:

- Оперативные поставки широкого спектра электронных компонентов отечественного и импортного производства напрямую от производителей и с крупнейших мировых складов;
- Поставка более 17-ти миллионов наименований электронных компонентов;
- Поставка сложных, дефицитных, либо снятых с производства позиций;
- Оперативные сроки поставки под заказ (от 5 рабочих дней);
- Экспресс доставка в любую точку России;
- Техническая поддержка проекта, помощь в подборе аналогов, поставка прототипов;
- Система менеджмента качества сертифицирована по Международному стандарту ISO 9001;
- Лицензия ФСБ на осуществление работ с использованием сведений, составляющих государственную тайну;
- Поставка специализированных компонентов (Xilinx, Altera, Analog Devices, Intersil, Interpoint, Microsemi, Aeroflex, Peregrine, Syfer, Eurofarad, Texas Instrument, Miteq, Cobham, E2V, MA-COM, Hittite, Mini-Circuits, General Dynamics и др.);

Помимо этого, одним из направлений компании «ЭлектроПласт» является направление «Источники питания». Мы предлагаем Вам помощь Конструкторского отдела:

- Подбор оптимального решения, техническое обоснование при выборе компонента;
- Подбор аналогов;
- Консультации по применению компонента;
- Поставка образцов и прототипов;
- Техническая поддержка проекта;
- Защита от снятия компонента с производства.



Как с нами связаться

Телефон: 8 (812) 309 58 32 (многоканальный)

Факс: 8 (812) 320-02-42

Электронная почта: org@eplast1.ru

Адрес: 198099, г. Санкт-Петербург, ул. Калинина, дом 2, корпус 4, литера А.