

Kinetis KL28Zxxx with 512 KB Flash and 128 KB SRAM

72 MHz Cortex-M0+ based Microcontroller

Supports ultra low power ARM based microcontroller with crystal-less USB feature, large flash and RAM, evolutionary low-power peripherals and security features. This is an ideal solution for Sensor Hub applications, Bluetooth, Wi-Fi connectivity, Smart Energy, Internet of Things, and Edge and Concentrator. This device offers:

- 128KB SRAM for data processing and connectivity stack
- Ultra low dynamic and static power consumption with smart peripherals for low power applications
- Advanced LPI2C and LPSPi supporting asynchronous DMA master data transition
- FlexIO for flexible and high performance interfaces
- Crypto acceleration with AES/DES/3DES/MD5/SHA and TRNG
- USB FS 2.0 device operation without need of external crystal

MKL28Z512Vxx7

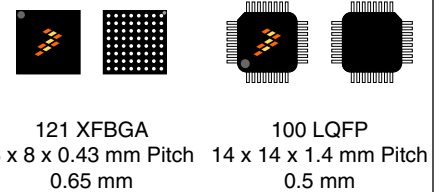

Core

- ARM® Cortex®-M0+ cores up to 72 MHz in Normal mode and 96 MHz in High Speed mode

Memories

- Up to 512 KB program flash memory
- 128 KB SRAM
- 32 KB ROM with built-in bootloader

System peripherals

- 8-channel DMA controller
- Independent clocked Watchdog
- Low-leakage wakeup unit
- SWD debug interface and Micro Trace Buffer
- Bit Manipulation Engine
- Memory Mapped Divide and Square Root module (MMDDVSQ)
- Cyclic Redundancy Check (CRC) module
- Nested Vector Interrupt Controller (NVIC) supports 32 interrupt vectors
- Additional peripheral interrupt support via Interrupt Multiplexer (INTMUX)

Clocks

- System Clock Generator module that includes the following clock sources:
 - 48 to 60 MHz high accuracy fast internal reference clock (FIRC)

Communication interfaces

- Three 16-bit Low Power Serial Peripheral Interface (LPSPi) modules
- One EMVSIM module supporting EMV version 4.3, ISO7816
- Three LPUART modules
- Three LPI2C modules supporting up to 5 Mbit/s
- One SAI module supporting I2S
- One FlexIO module emulating UART, SPI, I2S, camera interface, and Motorola 68K/Intel 8080 bus
- USB FS 2.0 device operation without need of external crystal

Analog Modules

- 16-bit, 24-channel SAR ADC with internal voltage reference
- Two High-speed analog comparators each containing a 6-bit DAC and programmable reference input
- One 12-bit DAC
- 1.2 V and 2.1 V voltage references (Vref)

Timers

- One 6-channel Timer/PWM module
- Two 2-channel Timer/PWM modules
- Two low-power timers
- Two periodic interrupt timers



- 32–40 kHz, or 3–32 MHz crystal oscillator
- 1 kHz LPO clock
- 8/2 MHz slow internal reference clock (SIRC)
- Peripheral Clock Control (PCC) module that supports asynchronous clocking and clock divide options for peripherals.

Human-machine interface

- General-purpose input/output up to 97
- Low-power hardware touch sensor interface (TSI)

- Secure Real time clock
- 56-bit software time stamp timer at 1 MHz

Security and integrity modules

- 80-bit unique identification number per chip
- MMCAU supports acceleration of the DES, 3DES, AES, MD5, SHA-1, and SHA-256 algorithms
- True Random Number Generator (TRNG)

Operating Characteristics

- Voltage range: 1.71 to 3.6 V
- Temperature range: –40 to 105 °C

NOTE

The 121-pin packages for this product is not yet available. However, it is included in a Package Your Way program for Kinetis MCUs. Visit nxp.com/KPYW for more details.

Ordering Information 1

Part Number	Memory		Package		IO and ADC channels		
	Flash (KB)	SRAM (KB)	Pin count	Package	GPIOs	GPIOs (INT/HD)	ADC channels (SE/DP)
MKL28Z512V LL7	512	128	100	LQFP	82	82/8	27/4
MKL28Z512V DC7 ²	512	128	121	XFBGA	97	97/8	27/4

1. To confirm current availability of orderable part numbers, go to <http://www.nxp.com> and perform a part number search.
2. Package Your Way.

Related Resources

Type	Description	Resource
Selector Guide	The NXP Solution Advisor is a web-based tool that features interactive application wizards and a dynamic product selector.	Solution Advisor
Product Brief	The Product Brief contains concise overview/summary information to enable quick evaluation of a device for design suitability.	KL2XPB ¹
Reference Manual	The Reference Manual contains a comprehensive description of the structure and function (operation) of a device.	MKL28ZRM ¹
Data Sheet	The Data Sheet includes electrical characteristics and signal connections.	MKL28Z512Vxx7 ¹
Chip Errata	The chip mask set Errata provides additional or corrective information for a particular device mask set.	KINETIS_L_1N52N ¹
Package drawing	Package dimensions are provided in package drawings.	<ul style="list-style-type: none"> • 121-XFBGA: 98ASA00595D¹ • 100-LQFP: 98ASS23308W¹

1. To find the associated resource, go to <http://www.nxp.com> and perform a search using this term.

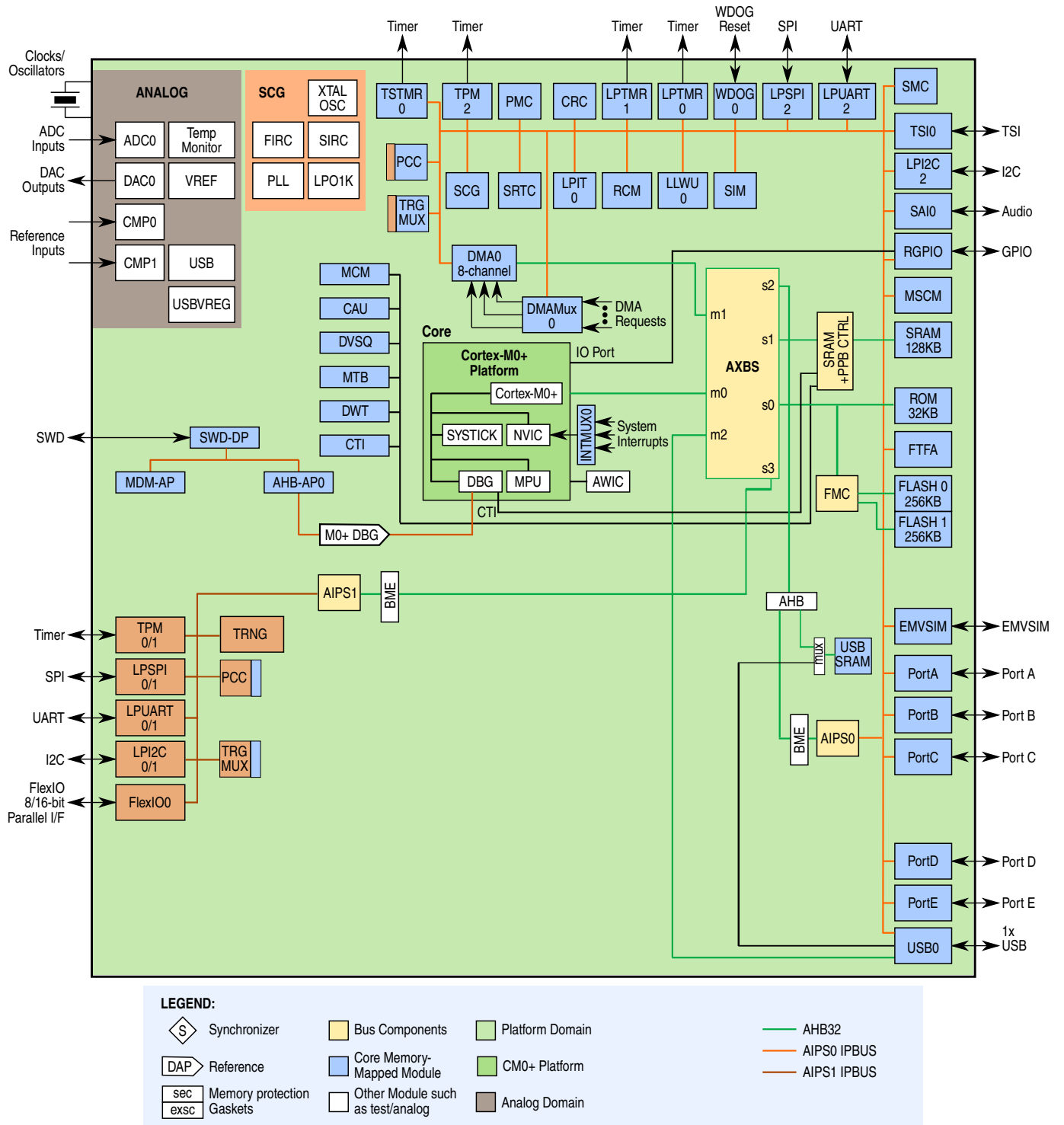

Figure 1. KL28Z block diagram

Table of Contents

1	Ratings.....	5	3.8	Communication interfaces.....	43
1.1	Thermal handling ratings.....	5	3.8.1	EMV SIM specifications.....	43
1.2	Moisture handling ratings.....	5	3.8.2	USB electrical specifications.....	48
1.3	ESD handling ratings.....	5	3.8.3	USB VREG electrical specifications.....	49
1.4	Voltage and current operating ratings.....	5	3.8.4	LPSPi switching specifications.....	49
2	General.....	6	3.8.5	LPI2C.....	54
2.1	AC electrical characteristics.....	6	3.8.6	LPUART.....	54
2.2	Nonswitching electrical specifications.....	7	3.8.7	I2S/SAI switching specifications.....	55
2.2.1	Voltage and current operating requirements.....	7	3.9	Human-machine interfaces (HMI).....	59
2.2.2	LVD, HVD, and POR operating requirements.....	7	3.9.1	TSI electrical specifications.....	59
2.2.3	Voltage and current operating behaviors.....	8	4	Dimensions.....	59
2.2.4	Power mode transition operating behaviors.....	9	4.1	Obtaining package dimensions.....	59
2.2.5	Power consumption operating behaviors.....	10	5	Pinouts and Packaging.....	60
2.2.6	EMC radiated emissions operating behaviors.....	19	5.1	KL28Z Signal Multiplexing and Pin Assignments.....	60
2.2.7	Designing with radiated emissions in mind.....	20	5.2	KL28Z Pinouts.....	65
2.2.8	Capacitance attributes.....	20	6	Ordering parts.....	67
2.3	Switching specifications.....	20	6.1	Determining valid orderable parts.....	67
2.3.1	Device clock specifications.....	20	7	Design considerations.....	68
2.3.2	General switching specifications.....	21	7.1	Hardware design considerations.....	68
2.4	Thermal specifications.....	23	7.1.1	Printed circuit board recommendations.....	68
2.4.1	Thermal operating requirements.....	23	7.1.2	Power delivery system.....	68
2.4.2	Thermal attributes.....	23	7.1.3	Analog design.....	69
3	Peripheral operating requirements and behaviors.....	24	7.1.4	Digital design.....	70
3.1	Core modules.....	24	7.1.5	Crystal oscillator.....	74
3.1.1	SWD electricals	24	7.2	Software considerations.....	75
3.2	System modules.....	26	8	Part identification.....	76
3.3	Clock modules.....	26	8.1	Description.....	76
3.3.1	System Clock Generation (SCG) specifications.....	26	8.2	Format.....	76
3.3.2	Oscillator electrical specifications.....	28	8.3	Fields.....	76
3.4	Memories and memory interfaces.....	30	8.4	Example.....	77
3.4.1	Flash electrical specifications.....	30	9	Terminology and guidelines.....	77
3.5	Security and integrity modules.....	32	9.1	Definitions.....	77
3.6	Analog.....	32	9.2	Examples.....	78
3.6.1	ADC electrical specifications.....	32	9.3	Typical-value conditions.....	78
3.6.2	Voltage reference electrical specifications.....	36	9.4	Relationship between ratings and operating requirements.....	79
3.6.3	CMP and 6-bit DAC electrical specifications.....	38	9.5	Guidelines for ratings and operating requirements.....	79
3.6.4	12-bit DAC electrical characteristics.....	40	10	Revision History.....	80
3.7	Timers.....	43			

1 Ratings

1.1 Thermal handling ratings

Table 1. Thermal handling ratings

Symbol	Description	Min.	Max.	Unit	Notes
T _{STG}	Storage temperature	-55	150	°C	1
T _{SDR}	Solder temperature, lead-free	—	260	°C	2

1. Determined according to JEDEC Standard JESD22-A103, *High Temperature Storage Life*.
2. Determined according to IPC/JEDEC Standard J-STD-020, *Moisture/Reflow Sensitivity Classification for Nonhermetic Solid State Surface Mount Devices*.

1.2 Moisture handling ratings

Table 2. Moisture handling ratings

Symbol	Description	Min.	Max.	Unit	Notes
MSL	Moisture sensitivity level	—	3	—	1

1. Determined according to IPC/JEDEC Standard J-STD-020, *Moisture/Reflow Sensitivity Classification for Nonhermetic Solid State Surface Mount Devices*.

1.3 ESD handling ratings

Table 3. ESD handling ratings

Symbol	Description	Min.	Max.	Unit	Notes
V _{HBM}	Electrostatic discharge voltage, human body model	-2000	+2000	V	1
V _{CDM}	Electrostatic discharge voltage, charged-device model	-500	+500	V	2
I _{LAT}	Latch-up current at ambient temperature of 105 °C	-100	+100	mA	3

1. Determined according to JEDEC Standard JESD22-A114, *Electrostatic Discharge (ESD) Sensitivity Testing Human Body Model (HBM)*.
2. Determined according to JEDEC Standard JESD22-C101, *Field-Induced Charged-Device Model Test Method for Electrostatic-Discharge-Withstand Thresholds of Microelectronic Components*.
3. Determined according to JEDEC Standard JESD78, *IC Latch-Up Test*.

1.4 Voltage and current operating ratings

Table 4. Voltage and current operating ratings

Symbol	Description	Min.	Max.	Unit
V_{DD}	Digital supply voltage	-0.3	3.8	V
I_{DD}	Digital supply current	—	120	mA
V_{IO}	IO pin input voltage	-0.3	$V_{DD} + 0.3$	V
I_D	Instantaneous maximum current single pin limit (applies to all port pins)	-25	25	mA
V_{DDA}	Analog supply voltage	$V_{DD} - 0.3$	$V_{DD} + 0.3$	V
V_{USB_DP}	USB_DP input voltage	-0.3	3.63	V
V_{USB_DM}	USB_DM input voltage	-0.3	3.63	V
V_{REGIN}	USB regulator input	-0.3	6.0	V

2 General

2.1 AC electrical characteristics

Unless otherwise specified, propagation delays are measured from the 50% to the 50% point, and rise and fall times are measured at the 20% and 80% points, as shown in the following figure.

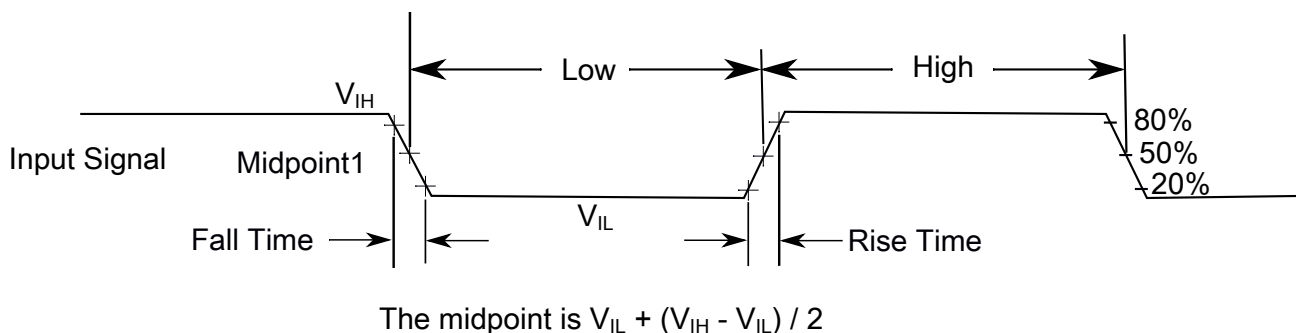

Figure 2. Input signal measurement reference

All digital I/O switching characteristics, unless otherwise specified, assume that the output pins have the following characteristics.

- $C_L=30$ pF loads
- Slew rate disabled
- Normal drive strength

2.2 Nonswitching electrical specifications

2.2.1 Voltage and current operating requirements

Table 5. Voltage and current operating requirements

Symbol	Description	Min.	Max.	Unit	Notes
V_{DD}	Supply voltage	1.71	3.6	V	
V_{DDA}	Analog supply voltage	1.71	3.6	V	
$V_{DD} - V_{DDA}$	V_{DD} -to- V_{DDA} differential voltage	-0.1	0.1	V	
$V_{SS} - V_{SSA}$	V_{SS} -to- V_{SSA} differential voltage	-0.1	0.1	V	
V_{IH}	Input high voltage <ul style="list-style-type: none"> • $2.7\text{ V} \leq V_{DD} \leq 3.6\text{ V}$ • $1.71\text{ V} \leq V_{DD} \leq 2.7\text{ V}$ 	$0.7 \times V_{DD}$	—	V	
		$0.75 \times V_{DD}$	—	V	
V_{IL}	Input low voltage <ul style="list-style-type: none"> • $2.7\text{ V} \leq V_{DD} \leq 3.6\text{ V}$ • $1.71\text{ V} \leq V_{DD} \leq 2.7\text{ V}$ 	—	$0.35 \times V_{DD}$	V	
		—	$0.3 \times V_{DD}$	V	
V_{HYS}	Input hysteresis	$0.06 \times V_{DD}$	—	V	
I_{ICIO}	IO pin negative DC injection current — single pin <ul style="list-style-type: none"> • $V_{IN} < V_{SS}-0.3\text{V}$ 	-5	—	mA	1
I_{ICcont}	Contiguous pin DC injection current —regional limit, includes sum of negative injection currents of 16 contiguous pins <ul style="list-style-type: none"> • Negative current injection 	-25	—	mA	
V_{ODPU}	Open drain pullup voltage level	V_{DD}	V_{DD}	V	2
V_{RAM}	V_{DD} voltage required to retain RAM	1.2	—	V	

- All I/O pins are internally clamped to V_{SS} through a ESD protection diode. There is no diode connection to V_{DD} . If V_{IN} greater than V_{IO_MIN} ($= V_{SS}-0.3\text{ V}$) is observed, then there is no need to provide current limiting resistors at the pads. If this limit cannot be observed then a current limiting resistor is required. The negative DC injection current limiting resistor is calculated as $R = (V_{IO_MIN} - V_{IN})/|I_{ICIO}|$.
- Open drain outputs must be pulled to V_{DD} .

2.2.2 LVD, HVD, and POR operating requirements

Table 6. V_{DD} supply LVD, HVD, and POR operating requirements

Symbol	Description	Min.	Typ.	Max.	Unit	Notes
V_{POR}	Falling V_{DD} POR detect voltage	0.8	1.1	1.5	V	—

Table continues on the next page...

Table 6. V_{DD} supply LVD, HVD, and POR operating requirements (continued)

Symbol	Description	Min.	Typ.	Max.	Unit	Notes
V _{LVDH}	Falling low-voltage detect threshold — high range (LVDV = 01)	2.48	2.56	2.64	V	—
V _{LVW1H}	Low-voltage warning thresholds — high range <ul style="list-style-type: none"> • Level 1 falling (LVWV = 00) • Level 2 falling (LVWV = 01) • Level 3 falling (LVWV = 10) • Level 4 falling (LVWV = 11) 	2.62	2.70	2.78	V	1
V _{LVW2H}		2.72	2.80	2.88	V	
V _{LVW3H}		2.82	2.90	2.98	V	
V _{LVW4H}		2.92	3.00	3.08	V	
V _{HYSH}	Low-voltage inhibit reset/recover hysteresis — high range	—	±60	—	mV	—
V _{LVDL}	Falling low-voltage detect threshold — low range (LVDV=00)	1.54	1.60	1.66	V	—
V _{LVW1L}	Low-voltage warning thresholds — low range <ul style="list-style-type: none"> • Level 1 falling (LVWV = 00) • Level 2 falling (LVWV = 01) • Level 3 falling (LVWV = 10) • Level 4 falling (LVWV = 11) 	1.74	1.80	1.86	V	1
V _{LVW2L}		1.84	1.90	1.96	V	
V _{LVW3L}		1.94	2.00	2.06	V	
V _{LVW4L}		2.04	2.10	2.16	V	
V _{HYSL}	Low-voltage inhibit reset/recover hysteresis — low range	—	±40	—	mV	—
V _{BG}	Bandgap voltage reference	0.97	1.00	1.03	V	—
t _{LPO}	Internal low power oscillator period — factory trimmed	900	1000	1100	µs	—
V _{HVDL}	High voltage detect threshold — low range (HVDV=0) — Rising	3.4	3.5	3.6	V	2
	High voltage detect threshold — low range (HVDV=0) — Falling	3.35	3.45	3.55		
V _{HVDH}	High voltage detect threshold — high range (HVDV=1) — Rising	3.65	3.75	3.85	V	2
	High voltage detect threshold — high range (HVDV=1) — Falling	3.6	3.7	3.8		
V _{HYSH}	High voltage detect hysteresis — low range (HVDV=0)	—	50	—	mV	—
	High voltage detect hysteresis — high range (HVDV=1)	—	50	—		

1. Rising thresholds are falling threshold + hysteresis voltage
2. The selection of high voltage detect trip voltage is controlled by PMC_HVDSC1[HVDV].

2.2.3 Voltage and current operating behaviors

Table 7. Voltage and current operating behaviors

Symbol	Description	Min.	Typ.	Max.	Unit	Notes
V _{OH}	Output high voltage — Normal drive pad <ul style="list-style-type: none"> • 2.7 V ≤ V_{DD} ≤ 3.6 V, I_{OH} = -5 mA • 1.71 V ≤ V_{DD} ≤ 2.7 V, I_{OH} = -2.5 mA 	V _{DD} - 0.5		—	V	1
		V _{DD} - 0.5		—	V	
V _{OH}	Output high voltage — High drive pad <ul style="list-style-type: none"> • 2.7 V ≤ V_{DD} ≤ 3.6 V, I_{OH} = -20 mA • 1.71 V ≤ V_{DD} ≤ 2.7 V, I_{OH} = -10 mA 	V _{DD} - 0.5		—	V	1
		V _{DD} - 0.5		—	V	
I _{OHT}	Output high current total for all ports	—		100	mA	
V _{OL}	Output low voltage — Normal drive pad <ul style="list-style-type: none"> • 2.7 V ≤ V_{DD} ≤ 3.6 V, I_{OL} = 5 mA • 1.71 V ≤ V_{DD} ≤ 2.7 V, I_{OL} = 2.5 mA 	—		0.5	V	1
		—		0.5	V	
V _{OL}	Output low voltage — High drive pad <ul style="list-style-type: none"> • 2.7 V ≤ V_{DD} ≤ 3.6 V, I_{OL} = 20 mA • 1.71 V ≤ V_{DD} ≤ 2.7 V, I_{OL} = 10 mA 	—		0.5	V	1
		—		0.5	V	
I _{OLT}	Output low current total for all ports	—		100	mA	
I _{IN}	Input leakage current (per pin) for full temperature range	—		1	μA	2
I _{IN}	Input leakage current (per pin) at 25 °C	—		0.025	μA	2
I _{IN}	Input leakage current (total all pins) for full temperature range	—		41	μA	2
I _{OZ}	Hi-Z (off-state) leakage current (per pin)	—		1	μA	
R _{PU}	Internal pullup resistors	20		50	kΩ	3

1. PTB0, PTB1, PTC3, PTC4, PTD4, PTD5, PTD6 and PTD7 I/O have both high drive and normal drive capability selected by the associated PORTx_PCRn[DSE] control bit. All other GPIOs are normal drive only. PTD4, PTD5, PTD6, PTD7, PTE20, PTE21, PTE22, and PTE23 are also fast pins.
2. Measured at V_{DD} = 3.6 V
3. Measured at V_{DD} supply voltage = V_{DD} min and V_{input} = V_{SS}

2.2.4 Power mode transition operating behaviors

All specifications in the following table assume this clock configuration in Run mode:

- CPU and system clocks = 48 MHz
- Bus and flash clock = 24 MHz
- SCG configured in FIRC mode; peripheral functional clocks from FIRCDIV3_CLK and USB clock from FIRCDIV1_CLK

Table 8. Power mode transition operating behaviors

Symbol	Description	Min.	Typ.	Max.	Unit	Notes
t _{POR}	After a POR event, amount of time from the point V _{DD} reaches 1.8 V to execution of the first instruction across the operating temperature range of the chip.	—	—	300	μs	1
	• VLLS0 → RUN	—	188	193	μs	
	• VLLS1 → RUN	—	188	193	μs	
	• VLLS2 → RUN	—	125	130	μs	
	• VLLS3 → RUN	—	125	130	μs	
	• LLS3 → RUN	—	5.5	6.1	μs	
	• LLS2 → RUN	—	5.5	6.1	μs	
	• VLPS → RUN	—	5.5	6.1	μs	
	• STOP → RUN	—	5.5	6.1	μs	

1. Normal boot (FTFA_FOPT[LPBOOT]=11).

2.2.5 Power consumption operating behaviors

NOTE

The values in the following table are based on characterization data with a few samples.

NOTE

The actual power consumption measured in the related condition, with certain peripherals running, is the sum of related low power current consumption of the device listed in [Table 9](#) and the related low power mode peripheral adders in [Table 10](#).

NOTE

The maximum values represent characterized results equivalent to the mean plus three times the standard deviation (mean + 3σ).

Table 9. Power consumption operating behaviors

Symbol	Description	Min.	Typ.	Max.	Unit	Notes
I _{DDA}	Analog supply current	—	—	See note	mA	1
I _{DD_HSRUN}	High speed run mode current at 96 MHz - all peripheral clocks disabled, code executing from flash, while(1) loop <ul style="list-style-type: none"> at 1.8 V at 3.0 V 	— —	12.6 12.8	17.4 17.6	mA mA	2
I _{DD_HSRUN}	High speed run mode current at 96 MHz - all peripheral clocks enabled, code executing from flash, while(1) loop <ul style="list-style-type: none"> at 1.8 V at 3.0 V 	— —	15.5 15.7	20.4 20.6	mA mA	3
I _{DD_RUN}	Run mode current at 72 MHz - all peripheral clocks disabled, code executing from flash, while(1) loop <ul style="list-style-type: none"> at 1.8 V at 3.0 V 	— —	9.4 9.6	13.6 13.8	mA mA	4
I _{DD_RUN}	Run mode current at 48 Mhz - all peripheral clocks disabled, code executing from flash, while(1) loop <ul style="list-style-type: none"> at 1.8 V at 3.0 V 	— —	7.3 7.4	11.4 11.5	mA mA	5
I _{DD_RUN}	Run mode current at 72 MHz - all peripheral clocks enabled, code executing from flash, while(1) loop <ul style="list-style-type: none"> at 1.8 V at 3.0 V 	— —	11.6 11.7	15.9 16.0	mA mA	6
I _{DD_RUN}	Run mode current at 48 Mhz - all peripheral clocks enabled, code executing from flash, while(1) loop <ul style="list-style-type: none"> at 1.8 V at 3.0 V 	— —	8.9 9.1	13.1 13.3	mA mA	7

Table continues on the next page...

Table 9. Power consumption operating behaviors (continued)

Symbol	Description	Min.	Typ.	Max.	Unit	Notes
I _{DD_WAIT}	Wait mode high frequency current at 72 MHz, at 3.0 V - all peripheral clocks disabled, while(1) loop	—	7.0	9.0	mA	4
I _{DD_WAIT}	Wait mode current at 3.0 V at 48 Mhz — all peripheral clocks disabled, while(1) loop	—	5.7	10.4	mA	5
I _{DD_VLPR}	Very-low-power run mode current at 3.0 V — all peripheral clocks enabled at 4 MHz, while(1) loop	—	483.7	1011.7	μA	8
I _{DD_VLPR}	Very-low-power run mode current at 3.0 V — all peripheral clocks enabled at 8 MHz, while(1) loop	—	557.6	1720.2	μA	9
I _{DD_VLPR}	Very-low-power run mode current at 3.0 V — all peripheral clocks disabled at 4 MHz, while(1) loop	—	400.3	926.5	μA	10
I _{DD_VLPR}	Very-low-power run mode current at 3.0 V — all peripheral clocks disabled at 8 MHz, while(1) loop	—	415.2	941.1	μA	11
I _{DD_VLPW}	Very-low-power wait mode current at 3.0 V — all peripheral clocks disabled at 4 MHz, while(1) loop	—	285.9	1145.6	μA	10
I _{DD_VLPW}	Very-low-power wait mode current at 3.0 V — all peripheral clocks disabled at 8 MHz, while(1) loop	—	415.6	1498.7	μA	11
I _{DD_STOP}	Stop mode current at 3.0 V <ul style="list-style-type: none"> • -40 to 25 °C • at 50 °C • at 70 °C • at 85 °C • at 105 °C 	—	264.5	320.5	μA	
I _{DD_VLPS}	Very-low-power stop mode current at 3.0 V <ul style="list-style-type: none"> • -40 to 25 °C • at 50 °C • at 70 °C • at 85 °C • at 105 °C 	—	4.2	16.4	μA	
I _{DD_LLS2}	Low-leakage stop mode 2 current at 3.0 V <ul style="list-style-type: none"> • -40 to 25 °C • at 50 °C • at 70 °C 	—	2.7	5.4	μA	
		—	4.7	10.6		
		—	8.6	22.7		
		—	14.7	49.0		

Table continues on the next page...

Table 9. Power consumption operating behaviors (continued)

Symbol	Description	Min.	Typ.	Max.	Unit	Notes
	<ul style="list-style-type: none"> at 85 °C at 105 °C 	—	30.4	88.6		
I _{DD_VLLS3}	Low-leakage stop mode 3 current at 3.0 V <ul style="list-style-type: none"> -40 to 25 °C at 50 °C at 70 °C at 85 °C at 105 °C 	—	3.0	5.9	μA	
		—	5.9	14.5		
		—	11.4	32.0		
		—	19.7	65.2		
		—	40.9	122.0		
I _{DD_VLLS3}	Very-low-leakage stop mode 3 current at 3.0 V <ul style="list-style-type: none"> -40 to 25 °C at 50 °C at 70 °C at 85 °C at 105 °C 	—	2.2	5.1	μA	
		—	4.6	10.9		
		—	9.0	24.4		
		—	15.9	44.8		
		—	33.1	91.0		
I _{DD_VLLS2}	Very-low-leakage stop mode 2 current at 3.0 V <ul style="list-style-type: none"> -40 to 25 °C at 50 °C at 70 °C at 85 °C at 105 °C 	—	1.8	3.4	μA	
		—	3.3	6.8		
		—	6.1	14.5		
		—	10.4	26.4		
		—	21.6	54.4		
I _{DD_VLLS1}	Very-low-leakage stop mode 1 current at 3.0V <ul style="list-style-type: none"> -40 to 25 °C at 50 °C at 70 °C at 85 °C at 105 °C 	—	0.65	0.88	μA	
		—	1.1	1.6		
		—	2.1	3.3		
		—	3.6	21.0		
		—	8.5	32.2		
I _{DD_VLLS0}	Very-low-leakage stop mode 0 current (SMC_STOPCTRL[PORPO] = 0) at 3.0 V <ul style="list-style-type: none"> -40 to 25 °C at 50 °C at 70 °C 	—	372.0	598	nA	
		—	768.6	1331		
		—	1734	3038		
		—	3291	20575		
		—	8025	27560		

Table continues on the next page...

Table 9. Power consumption operating behaviors (continued)

Symbol	Description	Min.	Typ.	Max.	Unit	Notes
	<ul style="list-style-type: none"> at 85 °C at 105 °C 					
I _{DD_VLLSO}	Very-low-leakage stop mode 0 current (SMC_STOPCTRL[PORPO] = 1) at 3.0 V <ul style="list-style-type: none"> -40 to 25 °C at 50 °C at 70 °C at 85 °C at 105 °C 	—	94.1	311	nA	12
		—	480.9	1024		
		—	1416	2760		
		—	2970	19574		
		—	7642	27325		

- The analog supply current is the sum of the active or disabled current for each of the analog modules on the device. See each module's specification for its supply current.
- 96 MHz core and system clock (DIVCORE_CLK), 24 MHz bus/slow clock(DIVSLOW_CLK), and 24 MHz flash clock. SCG configured as System PLL mode (SCG_HCCR[SCS]=0110), PLL clock source is SOSC from external 8 MHz crystal. All peripheral functional clocks disabled by clearing all xxDIV3, xxDIV2, and xxDIV1 in SCG_SOSCDIV and SCG_SPLLDIV registers. FIRC and SIRC disabled by clearing SCG_FIRCCSR[FIRCEN] and SCG_SIRCCSR[SIRCEN].
- 96 MHz core and system clock (DIVCORE_CLK), 24 MHz bus/slow clock(DIVSLOW_CLK), and 24 MHz flash clock. SCG configured as System PLL mode (SCG_HCCR[SCS]=0110), PLL clock source is SOSC from external 8 MHz crystal. All peripheral functional clocks except USB = 24 MHz from SPLLDIV3_CLK. USB functional clock = 48 MHz from SPLLDIV1_CLK. FIRC and SIRC disabled by clearing SCG_FIRCCSR[FIRCEN] and SCG_SIRCCSR[SIRCEN].
- 72 MHz core and system clock (DIVCORE_CLK), 24 MHz bus/slow clock(DIVSLOW_CLK), and 24 MHz flash clock. SCG configured as System PLL mode (SCG_RCCR[SCS]=0110), PLL clock source is SOSC from external 8 MHz crystal. All peripheral functional clocks disabled by clearing all xxDIV3, xxDIV2, and xxDIV1 in SCG_SOSCDIV and SCG_SPLLDIV registers. FIRC and SIRC disabled by clearing SCG_FIRCCSR[FIRCEN] and SCG_SIRCCSR[SIRCEN].
- 48 MHz core and system clock (DIVCORE_CLK), 24 MHz bus/slow clock(DIVSLOW_CLK), and 24 MHz flash clock. SCG configured as FIRC 48 MHz mode (SCG_RCCR[SCS]=0011). All peripheral functional clocks disabled by clearing all xxDIV3, xxDIV2, and xxDIV1 in SCG_FIRCDIV register. PLL, SOSC, and SIRC disabled by clearing SCG_SPLLCR[SPLLEN], SCG_SOSCCSR[SOSCEN], and SCG_SIRCCSR[SIRCEN].
- 72 MHz core and system clock (DIVCORE_CLK), 24 MHz bus/slow clock(DIVSLOW_CLK), and 24 MHz flash clock. SCG configured as System PLL mode (SCG_RCCR[SCS]=0110), PLL clock source is SOSC from external 8 MHz crystal. All peripheral functional clocks except USB = 24 MHz from SPLLDIV3_CLK. USB functional clock = 48 MHz from SPLLDIV1_CLK. FIRC and SIRC disabled by clearing SCG_FIRCCSR[FIRCEN] and SCG_SIRCCSR[SIRCEN].
- 48 MHz core and system clock (DIVCORE_CLK), 24 MHz bus/slow clock(DIVSLOW_CLK), and 24 MHz flash clock. SCG configured as FIRC 48 MHz mode (SCG_RCCR[SCS]=0011). All peripheral functional clocks except USB = 24 MHz from FIRCDIV3_CLK. USB functional clock = 48 MHz from FIRCDIV1_CLK. PLL, SOSC, and SIRC disabled by clearing SCG_SPLLCR[SPLLEN], SCG_SOSCCSR[SOSCEN], and SCG_SIRCCSR[SIRCEN].
- 4 MHz core and system clock (DIVCORE_CLK), 1 MHz bus/slow clock(DIVSLOW_CLK), and 1 MHz flash clock. SCG configured as SIRC 8 MHz mode (SCG_VCCR[SCS]=0010). All peripheral functional clocks except USB = 1M Hz from SIRCDIV3_CLK. USB clock disabled. PLL, SOSC, and FIRC disabled by clearing SCG_SPLLCR[SPLLEN], SCG_SOSCCSR[SOSCEN], and SCG_FIRCCSR[FIRCEN].
- 8 MHz core and system clock (DIVCORE_CLK), 1 MHz bus/slow clock(DIVSLOW_CLK), and 1 MHz flash clock. SCG configured as SIRC 8 MHz mode (SCG_VCCR[SCS]=0010). All peripheral functional clocks except USB = 1M Hz from SIRCDIV3_CLK. USB clock disabled. PLL, SOSC, and FIRC disabled by clearing SCG_SPLLCR[SPLLEN], SCG_SOSCCSR[SOSCEN], and SCG_FIRCCSR[FIRCEN].
- 4 MHz core and system clock (DIVCORE_CLK), 1 MHz bus/slow clock(DIVSLOW_CLK), and 1 MHz flash clock. SCG configured as SIRC 8 MHz mode (SCG_VCCR[SCS]=0010). All peripheral functional clocks disabled by clearing all xxDIV3, xxDIV2, and xxDIV1 in SCG_SIRCDIV register. PLL, SOSC, and FIRC disabled by clearing SCG_SPLLCR[SPLLEN], SCG_SOSCCSR[SOSCEN], and SCG_FIRCCSR[FIRCEN].
- 8 MHz core and system clock (DIVCORE_CLK), 1 MHz bus/slow clock(DIVSLOW_CLK), and 1 MHz flash clock. SCG configured as SIRC 8 MHz mode (SCG_VCCR[SCS]=0010). All peripheral functional clocks disabled by clearing all

xxDIV3, xxDIV2, and xxDIV1 in SCG_SIRCDIV register. PLL, SOSC, and FIRC disabled by clearing SCG_SPLLCR[SPLLEN], SCG_SOSCCSR[SOSCEN], and SCG_FIRCCSR[FIRCEN].

12. No brownout

Table 10. Low power mode peripheral adders — typical value

Symbol	Description	Temperature (°C)						Unit
		-40	25	50	70	85	105	
I _{EREFSTEN8MHz}	External 8 MHz crystal clock adder with System OSC. Measured by entering VLPS mode with the crystal enabled (SCG_SOSCCFG[RANGE] = 10, SCG_SOSCCFG[HGO] = 0, SCG_SOSCCFG[EREFS] = 1, and SC2P/SC4P/SC8P = 0).	402.9	462.1	477.5	492	506.2	530.4	uA
I _{EREFSTEN32KHz}	External 32 kHz crystal clock adder with System OSC by means of SCG_SOSCCFG[RANGE] = 01, SCG_SOSCCFG[HGO] = 0, SCG_SOSCCFG[EREFS] = 1, and SC2P/SC4P/SC8P = 0. Measured by entering all the following modes with the crystal enabled: <ul style="list-style-type: none"> • VLLS1 • VLLS3 • LLS3 • VLPS • STOP 							nA
		373.9	539.2	612.3	644.9	523.7	1000	
		568.4	552.6	650.8	757.9	995.6	1400	
		582.8	565.0	615.5	797.1	968.5	1700	
		472.4	635.2	776.9	425.6	1500	2800	
		528.0	534.1	636.6	9600	20300	40900	
I _{LPTMR}	LPTMR peripheral adder measured by placing the device in VLLS1 mode with LPTMR enabled using LPO clock.	151.0	7.7	21.8	7.6	174.0	31.0	nA
I _{CMP}	CMP peripheral adder measured by placing the device in VLLS1 mode with CMP enabled using the 6-bit DAC and a single external input for compare. Includes 6-bit DAC power consumption.	18.8	19.6	19.9	20.0	20.4	20.5	μA
I _{RTC}	RTC peripheral adder measured by placing the device in VLLS1 mode and the RTC ALARM set for 1 minute. Includes selected clock source power consumption. <ul style="list-style-type: none"> • OSC32KCLK (32KHz external crystal) • LPO (internal 1K Hz Low Power Oscillator) 							nA
		116.0	1400	1400	1500	1500	120.0	
		35.0	1400	1400	1600	1400	120.0	
I _{LPUART}	LPUART peripheral adder measured by placing the device in STOP mode with selected clock source waiting for RX data at 115200 baud rate. Includes							

Table continues on the next page...

Table 10. Low power mode peripheral adders — typical value (continued)

Symbol	Description	Temperature (°C)						Unit
		-40	25	50	70	85	105	
	selected clock source power consumption. <ul style="list-style-type: none"> Slow IRC clock from SCG (8 MHz internal reference clock) OSCERCLK (8 MHz external crystal) 	85.7	89.4	87.3	88.4	85.3	86.6	μA
		41.2	43.5	38.7	36.8	39.6	37.0	
I _{LPSPi}	LPSPi peripheral adder measured by placing the device in VLPS mode with selected clock source, LPSPi is configured as master mode with bit rate of 4 Mbps. Includes selected clock source power consumption. <ul style="list-style-type: none"> Slow IRC clock from SCG (8 MHz internal reference clock) OSCERCLK (8 MHz external crystal) 	69.4	66.7	65.9	66.1	65.8	66.0	μA
		431.9	489.9	503.5	518.6	533.0	557.0	
I _{TPM}	TPM peripheral adder measured by placing the device in STOP mode with selected clock source configured for output compare generating 100 Hz clock signal. No load is placed on the I/O generating the clock signal. Includes selected clock source and I/O switching currents. <ul style="list-style-type: none"> Slow IRC clock from SCG (8 MHz internal reference clock) OSCERCLK (8 MHz external crystal) 	80.7	84.2	84.2	84.4	84.8	86.3	μA
		35.5	37.2	37.3	37.1	37.7	37.7	
I _{LPI2C}	LPI2C peripheral adder measured by placing the device in VLPS mode with selected clock source, LPI2C is configured as master, and bit rate is 400 Kbps. Includes selected clock source power consumption. <ul style="list-style-type: none"> Slow IRC clock from SCG (8 MHz internal reference clock) OSCERCLK (8 MHz external crystal) 	69.7	66.7	66.9	67.6	68.2	68.2	μA
		582.9	597.9	610.8	623.8	637.0	660.2	
I _{BG}	Bandgap adder when BGEN bit is set and device is placed in VLPS mode. <ul style="list-style-type: none"> Bandgap buffer disabled Bandgap buffer enabled 	96.8	95.4	96.4	98.2	98.2	98.5	μA
		137.5	129.6	133.0	135.5	136.9	139.6	
I _{ADC}	ADC peripheral adder combining the measured values at V _{DD} and V _{DDA} by placing the device in STOP mode. ADC is configured for low power mode using the ADC asynchronous clock (ADACK) and continuous conversions.	372.9	380.5	384.0	388.3	392.2	394.6	μA

Table continues on the next page...

Table 10. Low power mode peripheral adders — typical value (continued)

Symbol	Description	Temperature (°C)						Unit
		-40	25	50	70	85	105	
I _{WDOG}	WDOG peripheral adder measured by placing the device in STOP mode, WDOG is configured to time out at 1 second. Includes selected clock source power consumption. <ul style="list-style-type: none"> Slow IRC clock from SCG (8 MHz internal reference clock) OSCERCLK (8 MHz external crystal) LPO (internal 1 kHz Lower Power Oscillator) 	68.8	68.5	69.2	69.9	71.7	72.6	μA
		11.2	10.1	10.1	10.2	10.5	10.7	
		56.0	57.1	58.6	58.5	58.6	60.0	
I _{SIRC_8MHz}	SIRC adder when SIRC is configured to 8 MHz. Measured by entering VLPS mode with 8 MHz IRC enabled, and SIRCDIV1, SIRCDIV2, SIRCDIV3 =000.	67.2	63.0	63.3	63.2	63.3	63.6	μA
I _{SIRC_2MHz}	SIRC adder when SIRC is configured to 2 MHz. Measured by entering STOP or VLPS mode with 2 MHz IRC enabled, and SIRCDIV1, SIRCDIV2, SIRCDIV3 =000.	22.3	21.2	21.4	21.5	21.7	21.4	μA

2.2.5.1 Diagram: Typical IDD_RUN operating behavior

The following data was measured under these conditions:

- SCG is configured as SPLL mode with SOSC as the clock source for RUN mode current measurement, and as SIRC mode for VLPR mode current measurement
- USB regulator disabled
- No GPIOs toggled
- Code execution from flash with cache enabled
- For the ALLOFF curve, all peripheral clocks are disabled except FTFA
- For the ALLON curve, all peripheral clocks are enabled as specified in notes of [Power consumption operating behaviors](#).

General

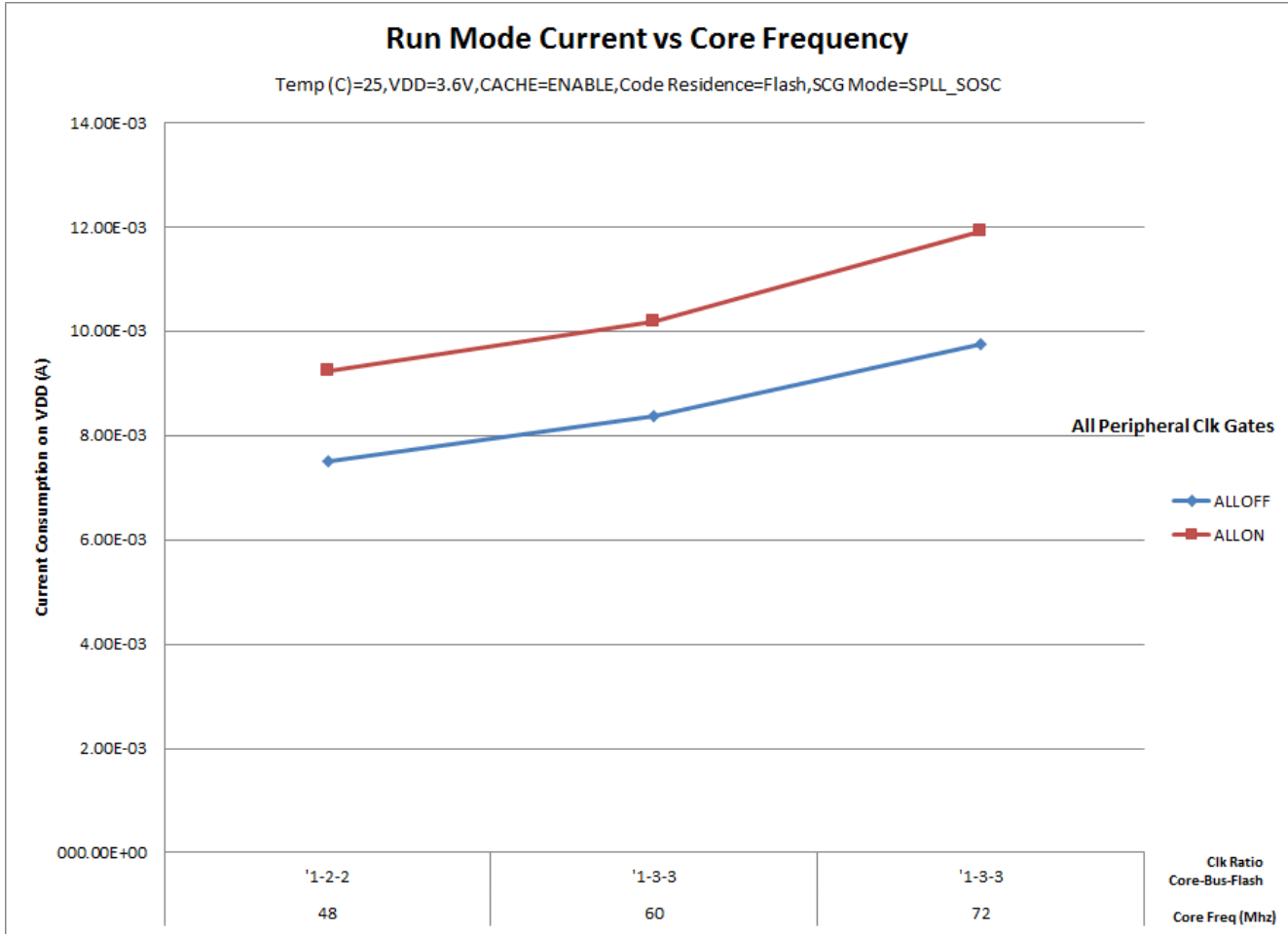

Figure 3. Run mode supply current vs. core frequency

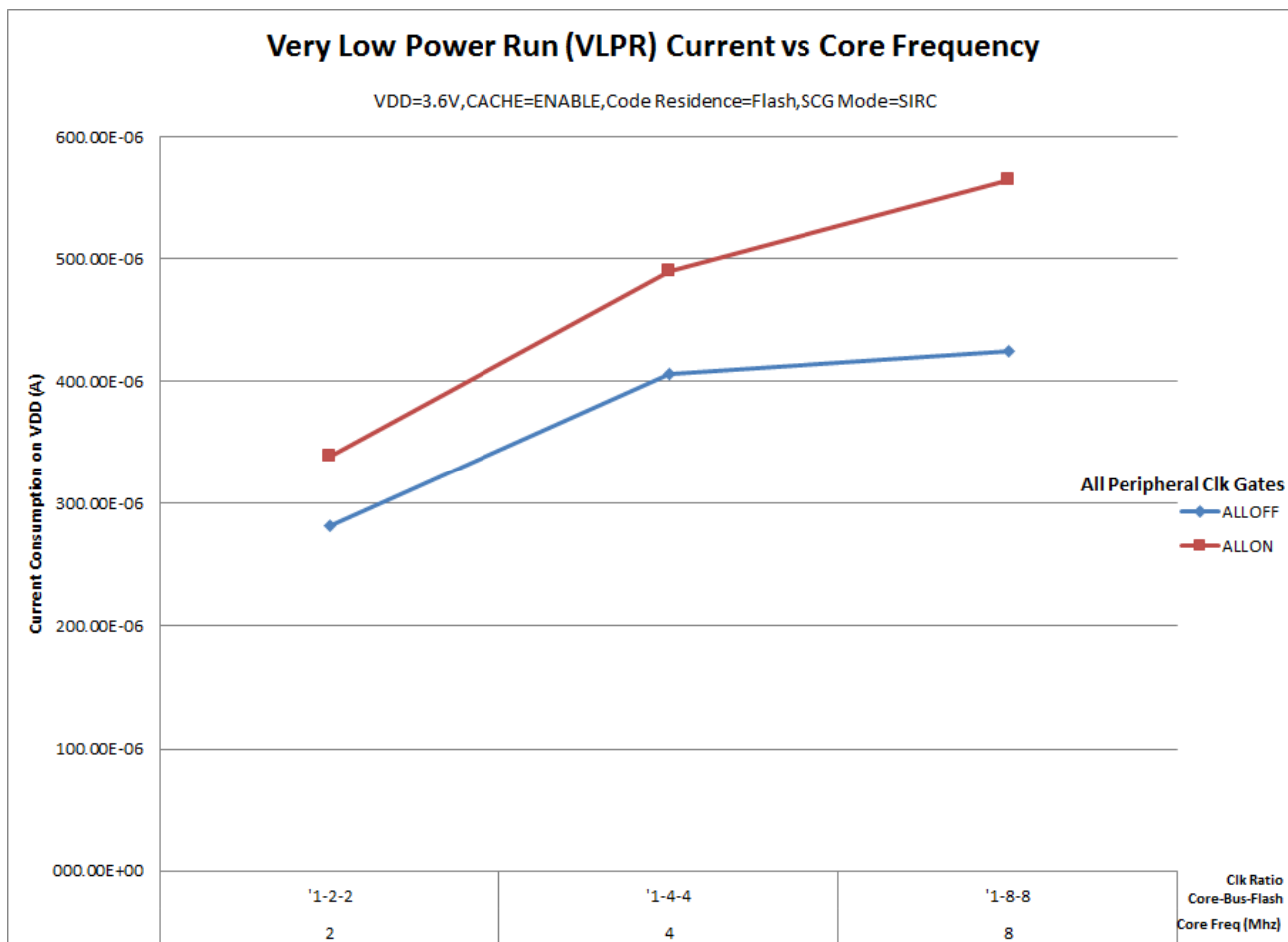

Figure 4. VLPR mode supply current vs. core frequency

2.2.6 EMC radiated emissions operating behaviors

Table 11. EMC radiated emissions operating behaviors

Symbol	Description	Frequency band (MHz)	Typ.	Unit	Notes
V _{RE1}	Radiated emissions voltage, band 1	0.15–50	18	dBμV	1, 2
V _{RE2}	Radiated emissions voltage, band 2	50–150	21	dBμV	
V _{RE3}	Radiated emissions voltage, band 3	150–500	21	dBμV	
V _{RE4}	Radiated emissions voltage, band 4	500–1000	24	dBμV	
V _{RE_IEC}	IEC level	0.15–1000	L	—	2, 3

1. Determined according to IEC Standard 61967-2 (and SAE J1752/3), *Integrated Circuits - Measurement of Electromagnetic Emissions, 150 kHz to 1 GHz Part 2: Measurement of Radiated Emissions—TEM Cell and Wideband TEM Cell Method*. Measurements were made while the microcontroller was running basic application code. The reported emission level is the value of the maximum measured emission, rounded up to the next whole number, from among the measured orientations in each frequency range.

General

2. $V_{DD} = 3.3\text{ V}$, $V_{REGIN} = 5\text{ V}$, $T_A = 25\text{ }^\circ\text{C}$, $f_{OSC} = 8\text{ MHz}$ (crystal), $f_{SYS_CORE} = 96\text{ MHz}$, $f_{BUS} = 24\text{ MHz}$
3. IEC/SAE level maximum: $L \leq 24\text{ dB mV}$

2.2.7 Designing with radiated emissions in mind

To find application notes that provide guidance on designing your system to minimize interference from radiated emissions:

1. Go to www.nxp.com.
2. Perform a keyword search for “EMC design.”

2.2.8 Capacitance attributes

Table 12. Capacitance attributes

Symbol	Description	Min.	Max.	Unit
C_{IN}	Input capacitance	—	7	pF

2.3 Switching specifications

2.3.1 Device clock specifications

Table 13. Device clock specifications

Symbol	Description	Min.	Max.	Unit	Run mode ¹
Normal run mode					
f_{SYS}	System and core clock (DIVCORE_CLK)	—	96	MHz	High speed run mode
		—	72	MHz	Normal speed run mode
		—	8	MHz	VLPR mode
f_{BUS}	Bus clock/Slow clock (DIVSLOW_CLK)	—	24	MHz	High speed run mode and Normal speed run mode
		—	1	MHz	VLPR mode
f_{FLASH}	Flash clock	—	24	MHz	High speed run mode and Normal speed run mode
		—	1	MHz	VLPR mode
f_{LLWU}	LLWU clock	—	1	KHz	All modes
f_{RCM}	RCM clock	—	1	KHz	All modes

Table continues on the next page...

Table 13. Device clock specifications (continued)

Symbol	Description	Min.	Max.	Unit	Run mode ¹
f_{WDOG} , f_{TSI}	WDOG clock, TSI clock	—	24	MHz	High speed run mode and Normal speed run mode
		—	1	MHz	VLPR mode
f_{ADC}	ADC clock	—	24 ²	MHz	High speed run mode and Normal speed run mode
		—	8	MHz	VLPR mode
f_{RTC}	RTC clock	—	32.768	KHz	All modes
f_{TSTMR}	TSTMR clock	—	1	MHz	All modes
f_{LPTMR}	LPTMR clock	—	24	MHz	All modes
f_{TPM} , f_{LPIT} , f_{LPSPi} , f_{LPI2C} , f_{LPUART} , f_{EMVSiM} , f_{SAI} , f_{FLEXIO}	TPM clock, LPIT clock, LPSPi clock, LPI2C clock, LPUART clock, EMVSiM clock, SAI clock, FlexIO clock	—	96	MHz	High speed run mode
		—	72	MHz	Normal speed run mode
		—	8	MHz	VLPR mode
f_{USB}	USB clock	—	48	MHz	High speed run mode and Normal speed run mode
		—	0	MHz	VLPR mode
f_{ERCLK}	External reference clock	—	48	MHz	High speed run mode and Normal speed run mode
		—	16	MHz	VLPR mode
$f_{osc_hi_2}$	Oscillator crystal or resonator frequency — high frequency mode (high range) (SCG_SOSCCFG[RANGE]=11)	—	32	MHz	High speed run mode and Normal speed run mode
		—	16	MHz	VLPR mode
f_{CAU} , f_{GPIO}	CAU clock, GPIO clock	—	96	MHz	High speed run mode
		—	72	MHz	Normal speed run mode
		—	8	MHz	VLPR mode

1. Normal run mode, High speed run mode, and VLPR mode.
2. See ADC electrical specifications

2.3.2 General switching specifications

These general-purpose specifications apply to all signals configured for GPIO, LPI2C, and LPUART signals.

Table 14. General switching specifications

Description	Min.	Max.	Unit	Notes
GPIO pin interrupt pulse width (digital glitch filter disabled) — Synchronous path	1.5	—	Bus clock cycles	1
GPIO pin interrupt pulse width (digital glitch filter disabled, analog filter enabled) — Asynchronous path	100	—	ns	
GPIO pin interrupt pulse width (digital glitch filter disabled, analog filter disabled) — Asynchronous path	50	—	ns	
External RESET and NMI pin interrupt pulse width — Asynchronous path	100	—	ns	2
GPIO pin interrupt pulse width — Asynchronous path	16	—	ns	2
Port rise/fall time				
Normal drive pins				3
<ul style="list-style-type: none"> • $2.7 \leq VDD \leq 3.6$ V <ul style="list-style-type: none"> • Fast slew rate • Slow slew rate • $1.71 \leq VDD \leq 2.7$ V <ul style="list-style-type: none"> • Fast slew rate • Slow slew rate 	—	3	ns	
	—	10.5		
	—	4		
	—	17		
High drive pins				4
Normal/low drive enabled	—	2.5	ns	
<ul style="list-style-type: none"> • $2.7 \leq VDD \leq 3.6$ V <ul style="list-style-type: none"> • Fast slew rate • Slow slew rate • $1.71 \leq VDD \leq 2.7$ V <ul style="list-style-type: none"> • Fast slew rate • Slow slew rate 	—	10.5		
	—	4		
	—	17		
High drive enabled	—	2		
<ul style="list-style-type: none"> • $2.7 \leq VDD \leq 3.6$ V <ul style="list-style-type: none"> • Fast slew rate • Slow slew rate • $1.71 \leq VDD \leq 2.7$ V <ul style="list-style-type: none"> • Fast slew rate • Slow slew rate 	—	11		
	—	2.5		
	—	17		
Normal drive fast pins				5
<ul style="list-style-type: none"> • $2.7 \leq VDD \leq 3.6$ V <ul style="list-style-type: none"> • Fast slew rate • Slow slew rate • $1.71 \leq VDD \leq 2.7$ V <ul style="list-style-type: none"> • Fast slew rate • Slow slew rate 	—	0.5	ns	
	—	10		
	—	0.75		
	—	19		
High drive fast pins				6
Normal/low drive enabled	—	0.5	ns	
<ul style="list-style-type: none"> • $2.7 \leq VDD \leq 3.6$ V 				

Table 14. General switching specifications

Description	Min.	Max.	Unit	Notes
<ul style="list-style-type: none"> Fast slew rate 	—	11		
<ul style="list-style-type: none"> Slow slew rate 	—	1		
<ul style="list-style-type: none"> $1.71 \leq VDD \leq 2.7$ V Fast slew rate 	—	19		
<ul style="list-style-type: none"> Slow slew rate 				
High drive enabled				
<ul style="list-style-type: none"> $2.7 \leq VDD \leq 3.6$ V Fast slew rate 	—	2		
<ul style="list-style-type: none"> Slow slew rate 	—	13		
<ul style="list-style-type: none"> $1.71 \leq VDD \leq 2.7$ V Fast slew rate 	—	4		
<ul style="list-style-type: none"> Slow slew rate 	—	21		

- The synchronous and asynchronous timing must be met.
- This is the shortest pulse that is guaranteed to be recognized.
- For high drive pins with high drive enabled, load is 75pF; other pins load (normal/low drive) is 25pF. Fast slew rate is enabled by clearing PORTx_PCRn[SRE].
- High drive pins are PTB0,PTB1, PTC3, and PTC4. High drive capability is enabled by setting PORTx_PCRn[DSE].
- Normal drive fast pins are PTE20, PTE21, PTE22, and PTE23.
- High drive fast pins are PTD4, PTD5, PTD6, and PTD7. High drive capability is enabled by setting PORTx_PCRn[DSE].

NOTE

Only PTA4, PTA20, and PTB19 pins have analog/passive filter.

2.4 Thermal specifications**2.4.1 Thermal operating requirements****Table 15. Thermal operating requirements**

Symbol	Description	Min.	Max.	Unit	Notes
T_J	Die junction temperature	-40	125	°C	
T_A	Ambient temperature	-40	105	°C	1

- Maximum T_A can be exceeded only if the user ensures that T_J does not exceed the maximum. The simplest method to determine T_J is: $T_J = T_A + R_{\theta JA} \times \text{chip power dissipation}$.

2.4.2 Thermal attributes

Table 16. Thermal attributes

Board type	Symbol	Description	100 LQFP	121 XFBGA	Unit	Notes
Single-layer (1S)	$R_{\theta JA}$	Thermal resistance, junction to ambient (natural convection)	64	94	°C/W	1
Four-layer (2s2p)	$R_{\theta JA}$	Thermal resistance, junction to ambient (natural convection)	51	57	°C/W	
Single-layer (1S)	$R_{\theta JMA}$	Thermal resistance, junction to ambient (200 ft./min. air speed)	54	81	°C/W	
Four-layer (2s2p)	$R_{\theta JMA}$	Thermal resistance, junction to ambient (200 ft./min. air speed)	45	53	°C/W	
—	$R_{\theta JB}$	Thermal resistance, junction to board	37	40	°C/W	2
—	$R_{\theta JC}$	Thermal resistance, junction to case	19	30	°C/W	3
—	Ψ_{JT}	Thermal characterization parameter, junction to package top outside center (natural convection)	4	8	°C/W	4

1. Determined according to JEDEC Standard JESD51-2, *Integrated Circuits Thermal Test Method Environmental Conditions—Natural Convection (Still Air)*, or EIA/JEDEC Standard JESD51-6, *Integrated Circuit Thermal Test Method Environmental Conditions—Forced Convection (Moving Air)*.
2. Determined according to JEDEC Standard JESD51-8, *Integrated Circuit Thermal Test Method Environmental Conditions—Junction-to-Board*.
3. Determined according to Method 1012.1 of MIL-STD 883, *Test Method Standard, Microcircuits*, with the cold plate temperature used for the case temperature. The value includes the thermal resistance of the interface material between the top of the package and the cold plate.
4. Determined according to JEDEC Standard JESD51-2, *Integrated Circuits Thermal Test Method Environmental Conditions—Natural Convection (Still Air)*.

3 Peripheral operating requirements and behaviors

3.1 Core modules

3.1.1 SWD electricals

Table 17. SWD full voltage range electricals

Symbol	Description	Min.	Max.	Unit
	Operating voltage	1.71	3.6	V
J1	SWD_CLK frequency of operation			

Table continues on the next page...

Table 17. SWD full voltage range electricals (continued)

Symbol	Description	Min.	Max.	Unit
	• Serial wire debug	0	25	MHz
J2	SWD_CLK cycle period	1/J1	—	ns
J3	SWD_CLK clock pulse width • Serial wire debug	20	—	ns
J4	SWD_CLK rise and fall times	—	3	ns
J9	SWD_DIO input data setup time to SWD_CLK rise	10	—	ns
J10	SWD_DIO input data hold time after SWD_CLK rise	0	—	ns
J11	SWD_CLK high to SWD_DIO data valid	—	32	ns
J12	SWD_CLK high to SWD_DIO high-Z	5	—	ns

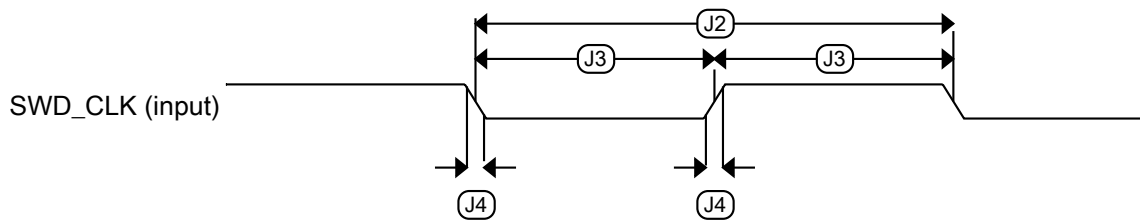
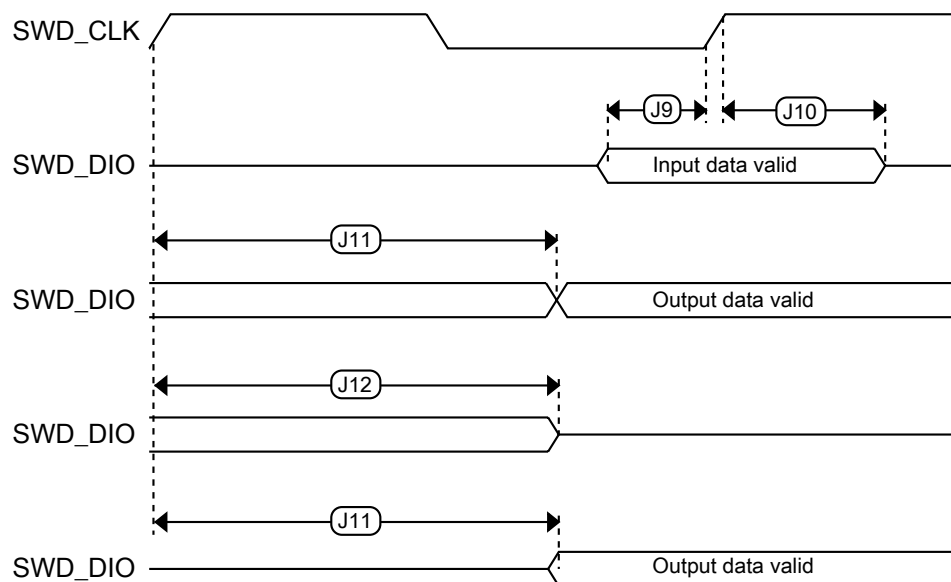
**Figure 5. Serial wire clock input timing****Figure 6. Serial wire data timing**

3.2 System modules

There are no specifications necessary for the device's system modules.

3.3 Clock modules

3.3.1 System Clock Generation (SCG) specifications

3.3.1.1 Fast IRC (FIRC) specifications

Table 18. Fast IRC (FIRC) specifications

Symbol	Description	Min.	Typ.	Max.	Unit	Notes
V_{dd_firc}	Supply voltage	1.71	—	3.6	V	
F_{firc_target}	IRC target frequency (nominal) Trim range = 00 Trim range = 01 Trim range = 10 Trim range = 11	—	48 52 56 60	—	MHz	1
$\Delta f_{firc_ol_lv}$	Open loop total deviation of FIRC frequency at low voltage (VDD=1.71V-1.89V) over full temperature • Regulator disable (SCG_FIRCCSR[FIRCREGOFF]=1) • Regulator enable (SCG_FIRCCSR[FIRCREGOFF]=0)	—	±0.5 ±0.5	±1.0 ±1.5	% F_{firc_target}	
$\Delta f_{firc_ol_hv}$	Open loop total deviation of FIRC frequency at high voltage (VDD=1.89V-3.6V) over full temperature Regulator enable (SCG_FIRCCSR[FIRCREGOFF]=0)	—	±0.5	±1.0	% F_{firc_target}	2
Δf_{firc_cl}	Fine Trim Resolution	—	—	± 0.1	% F_{firc_target}	
J_{cyc_firc}	Period Jitter (RMS)	—	35	150	ps	
T_{st_firc}	Startup time	—	2	3	μs	3
I_{dd_firc}	Current consumption: • 48 MHz • 52 MHz • 56 MHz • 60 MHz	— — — —	350 360 380 400	400 420 460 500	μA	

1. FIRC trim range is programmable via SCG_FIRCCFG[RANGE].

- Closed loop operation of the FIRC is only usable for USB device operation; it is not usable for USB host operation. It is enabled by configuring for USB Device, selecting FIRC as USB clock source, and enabling the clock recover function (USBn_CLK_RECOVER_CTRL[CLOCK_RECOVER_EN]=1, SCG_FIRCCSR[FIRCREGOFF]=0).
- FIRC startup time is defined as the time between clock enablement and clock availability for system use.

3.3.1.2 Slow IRC (SIRC) specifications

Table 19. Slow IRC specifications

Symbol	Description	Min.	Typ.	Max.	Unit	Notes
I_{DD_sirc2M}	Supply current in 2 MHz mode	—	14	17	μA	
I_{DD_sirc8M}	Supply current in 8 MHz mode	—	25	35	μA	
f_{sirc}	Output frequency	—	2	—	MHz	1
		—	8	—		
Δf_{sirc}	Total deviation of trimmed frequency over voltage and temperature <ul style="list-style-type: none"> 0 to 105 °C -40 to 0 °C 	—	—	± 3	$\%f_{sirc}$	2
		—	—	± 4		
Δf_{sirc_t}	Total deviation of trimmed frequency over temperature @ $V_{DD}=3.3V$	—	—	± 3	$\%f_{sirc}$	2
T_{su_sirc}	Startup time	—	—	12.5	μs	
J_{cyc_sirc}	Period jitter (RMS) <ul style="list-style-type: none"> $f_{sirc} = 2$ MHz $f_{sirc} = 8$ MHz 	—	350	—	ps	3
		—	100	—		

- Selection of output frequency for Slow IRC between 2 MHz and 8 MHz is controlled by SCG_SIRCCFG[RANGE].
- Maximum deviation occurs at cold temperature (-40 °C) and hot temperature (105 °C).
- This specification was obtained using a NXP developed PCB. Jitter is dependent on the noise characteristics of each PCB and results will vary.

3.3.1.3 System PLL specifications

Table 20. System PLL Specifications

Symbol	Description	Min.	Typ.	Max.	Unit	Notes
f_{pll_ref}	PLL reference frequency range	8	—	16	MHz	
f_{vcoclk_2x}	VCO output frequency	180	—	288	MHz	
f_{vcoclk}	PLL output frequency	90	—	144	MHz	
I_{pll}	PLL operating current — VCO @ 180 MHz ($f_{osc_hi_2} = 10$ MHz, $f_{pll_ref} = 10$ MHz, VDIV multiplier = 18)	—	1.1	—	mA	1
	PLL operating current — VCO @ 288 MHz ($f_{osc_hi_2} = 32$ MHz, $f_{pll_ref} = 8$ MHz, VDIV multiplier = 36)	—	2.0	—		
J_{cyc_pll}	PLL period jitter (RMS) <ul style="list-style-type: none"> $f_{vco} = 180$ MHz $f_{vco} = 288$ MHz 	—	120	—	ps	2
		—	80	—		

Table continues on the next page...

**Table 20. System PLL Specifications
(continued)**

Symbol	Description	Min.	Typ.	Max.	Unit	Notes
J_{acc_pll}	PLL accumulated jitter over 1 μ s (RMS) <ul style="list-style-type: none"> $f_{vco} = 180$ MHz $f_{vco} = 288$ MHz 	—	600	—	ps	2
D_{unl}	Lock exit frequency tolerance	± 4.47	—	± 5.97	%	
t_{pll_lock}	Lock detector detection time	—	—	150×10^{-6} + $1075(1/f_{pll_ref})$	s	3

1. Excludes any oscillator currents that are also consuming power while PLL is in operation.
2. This specification was obtained using a Freescale developed PCB. PLL jitter is dependent on the noise characteristics of each PCB and results will vary.
3. This specification applies to any time the PLL VCO divider or reference divider is changed, or changing from PLL disabled to PLL enabled. If a crystal/resonator is being used as the reference, this specification assumes it is already running.

3.3.2 Oscillator electrical specifications

3.3.2.1 Oscillator DC electrical specifications

Table 21. Oscillator DC electrical specifications

Symbol	Description	Min.	Typ.	Max.	Unit	Notes
V_{DD}	Supply voltage	1.71	—	3.6	V	
I_{DDOSC}	Supply current — low-power mode (HGO=0) <ul style="list-style-type: none"> 32 kHz 4 MHz 8 MHz (RANGE=01) 16 MHz 24 MHz 32 MHz 	—	500	—	nA	1
		—	200	—	μ A	
		—	300	—	μ A	
		—	950	—	μ A	
		—	1.2	—	mA	
		—	1.5	—	mA	
I_{DDOSC}	Supply current — high gain mode (HGO=1) <ul style="list-style-type: none"> 32 kHz 4 MHz 8 MHz (RANGE=01) 16 MHz 24 MHz 32 MHz 	—	25	—	μ A	1
		—	400	—	μ A	
		—	500	—	μ A	
		—	2.5	—	mA	
		—	3	—	mA	
		—	4	—	mA	

Table continues on the next page...

Table 21. Oscillator DC electrical specifications (continued)

Symbol	Description	Min.	Typ.	Max.	Unit	Notes
C_x	EXTAL load capacitance	—	—	—		2, 3
C_y	XTAL load capacitance	—	—	—		2, 3
R_F	Feedback resistor — low-frequency, low-power mode (HGO=0)	—	—	—	M Ω	2, 4
	Feedback resistor — low-frequency, high-gain mode (HGO=1)	—	10	—	M Ω	
	Feedback resistor — high-frequency, low-power mode (HGO=0)	—	—	—	M Ω	
	Feedback resistor — high-frequency, high-gain mode (HGO=1)	—	1	—	M Ω	
R_S	Series resistor — low-frequency, low-power mode (HGO=0)	—	—	—	k Ω	
	Series resistor — low-frequency, high-gain mode (HGO=1)	—	200	—	k Ω	
	Series resistor — high-frequency, low-power mode (HGO=0)	—	—	—	k Ω	
	Series resistor — high-frequency, high-gain mode (HGO=1)	—	0	—	k Ω	
V_{pp} ⁵	Peak-to-peak amplitude of oscillation (oscillator mode) — low-frequency, low-power mode (HGO=0)	—	0.6	—	V	
	Peak-to-peak amplitude of oscillation (oscillator mode) — low-frequency, high-gain mode (HGO=1)	—	V_{DD}	—	V	
	Peak-to-peak amplitude of oscillation (oscillator mode) — high-frequency, low-power mode (HGO=0)	—	1.0	—	V	
	Peak-to-peak amplitude of oscillation (oscillator mode) — high-frequency, high-gain mode (HGO=1)	—	V_{DD}	—	V	

1. $V_{DD}=3.3$ V, Temperature =25 °C
2. See crystal or resonator manufacturer's recommendation
3. C_x, C_y can be provided by using the integrated capacitors when the low frequency oscillator (RANGE = 00) is used. For all other cases external capacitors must be used.
4. When low power mode is selected, R_F is integrated and must not be attached externally.
5. The EXTAL and XTAL pins should only be connected to required oscillator components and must not be connected to any other devices.

3.3.2.2 Oscillator frequency specifications

Table 22. Oscillator frequency specifications

Symbol	Description	Min.	Typ.	Max.	Unit	Notes
f_{osc_lo}	Oscillator crystal or resonator frequency — low-frequency range (SCG_SOSCCFG[RANGE]=01)	32	—	40	kHz	
$f_{osc_hi_1}$	Oscillator crystal or resonator frequency — medium frequency range (SCG_SOSCCFG[RANGE]=10)	1	—	8	MHz	
$f_{osc_hi_2}$	Oscillator crystal or resonator frequency — high frequency range (SCG_SOSCCFG[RANGE]=11)	8	—	32	MHz	
f_{ec_extal}	Input clock frequency (external clock mode)	—	—	48	MHz	1, 2
t_{dc_extal}	Input clock duty cycle (external clock mode)	40	50	60	%	
t_{cst}	Crystal startup time — 32 kHz low-frequency, low-power mode (HGO=0)	—	750	—	ms	3, 4, 5
	Crystal startup time — 32 kHz low-frequency, high-gain mode (HGO=1)	—	250	—	ms	
	Crystal startup time — 8 MHz medium frequency (SCG_SOSCCFG[RANGE]=11), low-power mode (HGO=0)	—	0.6	—	ms	
	Crystal startup time — 8 MHz medium frequency (SCG_SOSCCFG[RANGE]=10), high-gain mode (HGO=1)	—	1	—	ms	

1. Other frequency limits may apply when external clock is being used as a reference for the PLL.
2. When transitioning to system PLL mode, restrict the frequency of the input clock so that, when it is divided by PREDIV, it remains within the limits of the PLL reference input clock frequency.
3. Proper PC board layout procedures must be followed to achieve specifications.
4. Crystal startup time is defined as the time between the oscillator being enabled and the SCG_SOSCCSR[SOSCVLD] being set.
5. Crystal startup time is dependent on external crystal and/or resonator and loading capacitance as well as series resistance.

3.4 Memories and memory interfaces

3.4.1 Flash electrical specifications

This section describes the electrical characteristics of the flash memory module.

3.4.1.1 Flash timing specifications — program and erase

The following specifications represent the amount of time the internal charge pumps are active and do not include command overhead.

Table 23. NVM program/erase timing specifications

Symbol	Description	Min.	Typ.	Max.	Unit	Notes
t_{hvpgm4}	Longword Program high-voltage time	—	7.5	18	μ s	—
$t_{hversscr}$	Sector Erase high-voltage time	—	13	113	ms	1
$t_{hversblk128k}$	Erase Block high-voltage time for 128 KB	—	52	452	ms	1
$t_{hversall}$	Erase All high-voltage time	—	104	904	ms	1

1. Maximum time based on expectations at cycling end-of-life.

3.4.1.2 Flash timing specifications — commands

Table 24. Flash command timing specifications

Symbol	Description	Min.	Typ.	Max.	Unit	Notes
$t_{rd1blk128k}$	Read 1s Block execution time • 128 KB program flash	—	—	1.7	ms	1
$t_{rd1sec1k}$	Read 1s Section execution time (flash sector)	—	—	60	μ s	1
t_{pgmchk}	Program Check execution time	—	—	45	μ s	1
t_{rdsrc}	Read Resource execution time	—	—	30	μ s	1
t_{pgm4}	Program Longword execution time	—	65	145	μ s	—
$t_{ersblk128k}$	Erase Flash Block execution time • 128 KB program flash	—	88	600	ms	2
t_{ersscr}	Erase Flash Sector execution time	—	14	114	ms	2
t_{rd1all}	Read 1s All Blocks execution time	—	—	1.8	ms	1
t_{rdonce}	Read Once execution time	—	—	25	μ s	1
$t_{pgmonce}$	Program Once execution time	—	65	—	μ s	—
t_{ersall}	Erase All Blocks execution time	—	175	1300	ms	2
t_{vfykey}	Verify Backdoor Access Key execution time	—	—	30	μ s	1

1. Assumes 25 MHz flash clock frequency.

2. Maximum times for erase parameters based on expectations at cycling end-of-life.

3.4.1.3 Flash high voltage current behaviors

Table 25. Flash high voltage current behaviors

Symbol	Description	Min.	Typ.	Max.	Unit
I_{DD_PGM}	Average current adder during high voltage flash programming operation	—	2.5	6.0	mA
I_{DD_ERS}	Average current adder during high voltage flash erase operation	—	1.5	4.0	mA

3.4.1.4 Reliability specifications

Table 26. NVM reliability specifications

Symbol	Description	Min.	Typ. ¹	Max.	Unit	Notes
Program Flash						
$t_{nvmretp10k}$	Data retention after up to 10 K cycles	5	50	—	years	—
$t_{nvmretp1k}$	Data retention after up to 1 K cycles	20	100	—	years	—
$n_{nvmcycp}$	Cycling endurance	10 K	50 K	—	cycles	2

1. Typical data retention values are based on measured response accelerated at high temperature and derated to a constant 25 °C use profile. Engineering Bulletin EB618 does not apply to this technology. Typical endurance defined in Engineering Bulletin EB619.
2. Cycling endurance represents number of program/erase cycles at $-40\text{ °C} \leq T_j \leq 125\text{ °C}$.

3.5 Security and integrity modules

There are no specifications necessary for the device's security and integrity modules.

3.6 Analog

3.6.1 ADC electrical specifications

3.6.1.1 16-bit ADC operating conditions

Table 27. 16-bit ADC operating conditions

Symbol	Description	Conditions	Min.	Typ. ¹	Max.	Unit	Notes
V_{DDA}	Supply voltage	Absolute	1.71	—	3.6	V	—
ΔV_{DDA}	Supply voltage	Delta to V_{DD} ($V_{DD} - V_{DDA}$)	-100	0	+100	mV	2
ΔV_{SSA}	Ground voltage	Delta to V_{SS} ($V_{SS} - V_{SSA}$)	-100	0	+100	mV	2
V_{ADIN}	Input voltage	<ul style="list-style-type: none"> • 16-bit differential mode • All other modes 	VREFL	—	31/32 × VREFH	V	—
C_{ADIN}	Input capacitance	<ul style="list-style-type: none"> • 16-bit mode • 8-bit / 10-bit / 12-bit modes 	—	8	10	pF	—
R_{ADIN}	Input series resistance		—	2	5	kΩ	—
R_{AS}	Analog source resistance	16-bit modes <ul style="list-style-type: none"> • $f_{ADCK} > 8\text{ MHz}$ 	—	—	0.5	kΩ	3, 4

Table continues on the next page...

Table 27. 16-bit ADC operating conditions (continued)

Symbol	Description	Conditions	Min.	Typ. ¹	Max.	Unit	Notes
		<ul style="list-style-type: none"> $f_{ADCK} = 4\text{--}8\text{ MHz}$ $f_{ADCK} < 4\text{ MHz}$ 	—	—	1	k Ω	
		<ul style="list-style-type: none"> $f_{ADCK} < 4\text{ MHz}$ 	—	—	2	k Ω	
		13-bit / 12-bit modes					
		<ul style="list-style-type: none"> $f_{ADCK} > 16\text{ MHz}$ 	—	—	0.5	k Ω	
		<ul style="list-style-type: none"> $f_{ADCK} > 8\text{ MHz}$ 	—	—	1	k Ω	
		<ul style="list-style-type: none"> $f_{ADCK} = 4\text{--}8\text{ MHz}$ 	—	—	2	k Ω	
		<ul style="list-style-type: none"> $f_{ADCK} < 4\text{ MHz}$ 	—	—	5	k Ω	
		11-bit / 10-bit modes					
		<ul style="list-style-type: none"> $f_{ADCK} > 8\text{ MHz}$ 	—	—	2	k Ω	
		<ul style="list-style-type: none"> $f_{ADCK} = 4\text{--}8\text{ MHz}$ 	—	—	5	k Ω	
		<ul style="list-style-type: none"> $f_{ADCK} < 4\text{ MHz}$ 	—	—	10	k Ω	
		9-bit / 8-bit modes					
		<ul style="list-style-type: none"> $f_{ADCK} > 8\text{ MHz}$ 	—	—	5	k Ω	
		<ul style="list-style-type: none"> $f_{ADCK} < 8\text{ MHz}$ 	—	—	10	k Ω	
f_{ADCK}	ADC conversion clock frequency	\leq 13-bit mode	1.0	—	24.0	MHz	5
		16-bit mode	2.0	—	12.0	MHz	
C_{rate}	ADC conversion rate	\leq 13-bit modes					6
		No ADC hardware averaging	20.000	—	1200	ksps	
		Continuous conversions enabled, subsequent conversion time					
C_{rate}	ADC conversion rate	16-bit mode					6
		No ADC hardware averaging	37.037	—	461.467	ksps	
		Continuous conversions enabled, subsequent conversion time					

1. Typical values assume $V_{DDA} = 3.0\text{ V}$, $\text{Temp} = 25\text{ }^{\circ}\text{C}$, $f_{ADCK} = 1.0\text{ MHz}$, unless otherwise stated. Typical values are for reference only, and are not tested in production.
2. DC potential difference.
3. Assumes $ADLSMP=0$
4. This resistance is external to the MCU. To achieve the best results, the analog source resistance must be kept as low as possible. The results in this data sheet were derived from a system that had $< 8\text{ }\Omega$ analog source resistance. The $R_{AS} * C_{AS}$ time constant should be kept to $< 1\text{ ns}$.
5. To use the maximum ADC conversion clock frequency, $CFG2[ADHSC]$ must be set and $CFG1[ADLPC]$ must be clear.
6. For guidelines and examples of conversion rate calculation, download the [ADC calculator tool](#).

ADC electrical specifications

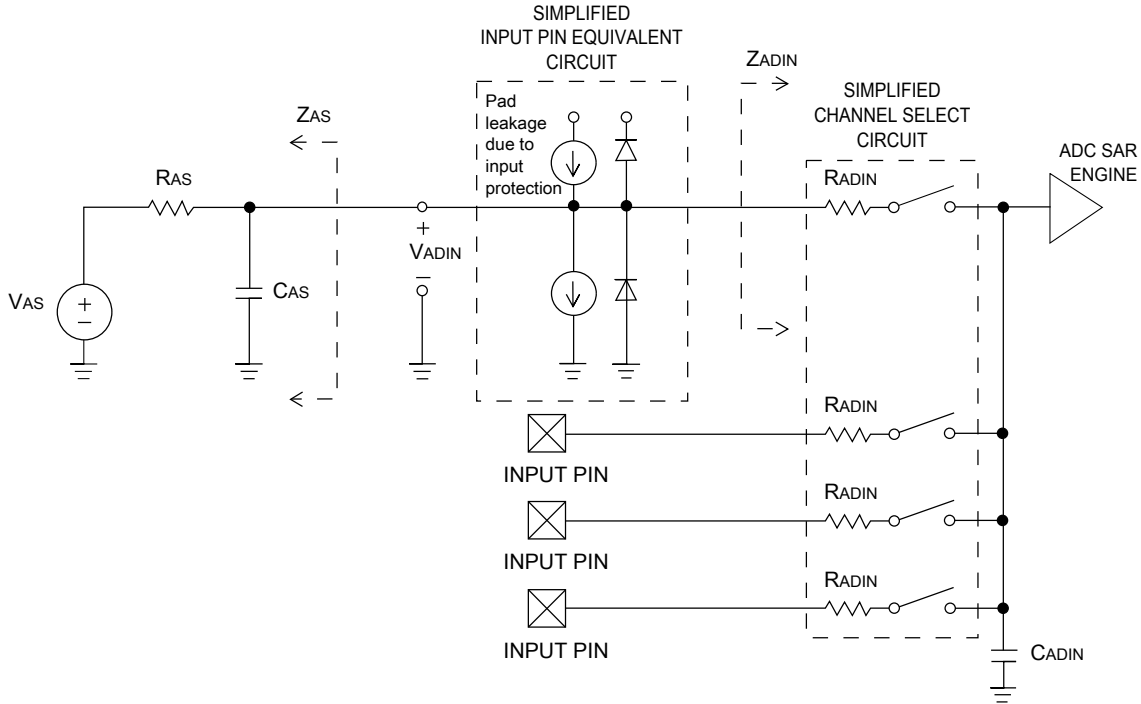

Figure 7. ADC input impedance equivalency diagram

3.6.1.2 16-bit ADC electrical characteristics

Table 28. 16-bit ADC characteristics ($V_{REFH} = V_{DDA}$, $V_{REFL} = V_{SSA}$)

Symbol	Description	Conditions ¹	Min.	Typ. ²	Max.	Unit	Notes
I_{DDA_ADC}	Supply current		0.215	—	1.7	mA	3
f_{ADACK}	ADC asynchronous clock source	<ul style="list-style-type: none"> • ADLPC = 1, ADHSC = 0 • ADLPC = 1, ADHSC = 1 • ADLPC = 0, ADHSC = 0 • ADLPC = 0, ADHSC = 1 	1.2	2.4	3.9	MHz	$t_{ADACK} = 1/f_{ADACK}$
			2.4	4.0	6.1	MHz	
			3.0	5.2	7.3	MHz	
			4.4	6.2	9.5	MHz	
	Sample Time	See Reference Manual chapter for sample times					
TUE	Total unadjusted error	<ul style="list-style-type: none"> • 12-bit modes • <12-bit modes 	—	±4	±6.8	LSB ⁴	5
DNL	Differential non-linearity	<ul style="list-style-type: none"> • 12-bit modes • <12-bit modes 	—	±0.7	-1.1 to +1.9	LSB ⁴	5
INL	Integral non-linearity	<ul style="list-style-type: none"> • 12-bit modes • <12-bit modes 	—	±1.0	-2.7 to +1.9	LSB ⁴	5

Table continues on the next page...

Table 28. 16-bit ADC characteristics ($V_{REFH} = V_{DDA}$, $V_{REFL} = V_{SSA}$) (continued)

Symbol	Description	Conditions ¹	Min.	Typ. ²	Max.	Unit	Notes
					-0.7 to +0.5		
E_{FS}	Full-scale error	<ul style="list-style-type: none"> 12-bit modes <12-bit modes 	—	-4	-5.4	LSB ⁴	$V_{ADIN} = V_{DDA}$ ⁵
E_Q	Quantization error	<ul style="list-style-type: none"> 16-bit modes ≤13-bit modes 	—	-1 to 0	—	LSB ⁴	
ENOB	Effective number of bits	16-bit differential mode					6
		<ul style="list-style-type: none"> Avg = 32 Avg = 4 	12.8	14.5	—	bits	
			11.9	13.8	—	bits	
		16-bit single-ended mode					
		<ul style="list-style-type: none"> Avg = 32 Avg = 4 	12.2	13.9	—	bits	
			11.4	13.1	—	bits	
SINAD	Signal-to-noise plus distortion	See ENOB	6.02 × ENOB + 1.76			dB	
THD	Total harmonic distortion	16-bit differential mode				dB	7
		<ul style="list-style-type: none"> Avg = 32 	—	-94	—	dB	
		16-bit single-ended mode					
		<ul style="list-style-type: none"> Avg = 32 	—	-85	—		
SFDR	Spurious free dynamic range	16-bit differential mode				dB	7
		<ul style="list-style-type: none"> Avg = 32 	82	95	—	dB	
		16-bit single-ended mode					
		<ul style="list-style-type: none"> Avg = 32 	78	90			
E_{IL}	Input leakage error		$I_{in} \times R_{AS}$			mV	I_{in} = leakage current (refer to the MCU's voltage and current operating ratings)
	Temp sensor slope	Across the full temperature range of the device	1.55	1.62	1.69	mV/°C	8
V_{TEMP25}	Temp sensor voltage	25 °C	706	716	726	mV	8

- All accuracy numbers assume the ADC is calibrated with $V_{REFH} = V_{DDA}$
- Typical values assume $V_{DDA} = 3.0$ V, Temp = 25 °C, $f_{ADCK} = 2.0$ MHz unless otherwise stated. Typical values are for reference only and are not tested in production.
- The ADC supply current depends on the ADC conversion clock speed, conversion rate and ADC_CFG1[ADLPC] (low power). For lowest power operation, ADC_CFG1[ADLPC] must be set, the ADC_CFG2[ADHSC] bit must be clear with 1 MHz ADC conversion clock speed.

ADC electrical specifications

- 1 LSB = $(V_{REFH} - V_{REFL})/2^N$
- ADC conversion clock < 16 MHz, Max hardware averaging (AVGE = %1, AVGS = %11)
- Input data is 100 Hz sine wave. ADC conversion clock < 12 MHz.
- Input data is 1 kHz sine wave. ADC conversion clock < 12 MHz.
- ADC conversion clock < 3 MHz

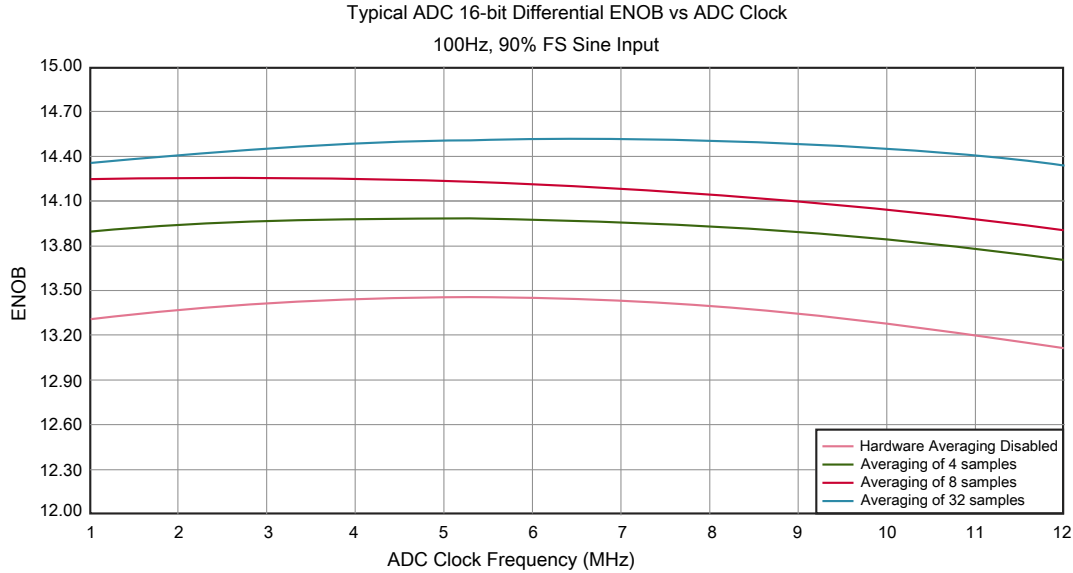

Figure 8. Typical ENOB vs. ADC_CLK for 16-bit differential mode

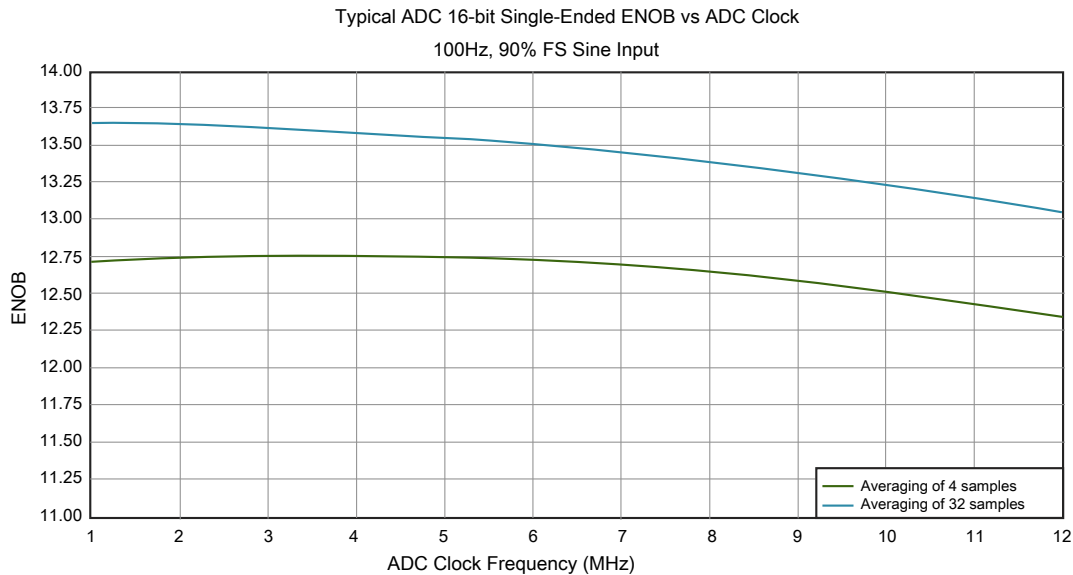

Figure 9. Typical ENOB vs. ADC_CLK for 16-bit single-ended mode

3.6.2 Voltage reference electrical specifications

Table 29. VREF full-range operating requirements

Symbol	Description	Min.	Max.	Unit	Notes
V _{DDA}	Supply voltage for 1.2V output		3.6	V	—
	Supply voltage for 2.1V output	2.4	3.6	V	—
T _A	Temperature	Operating temperature range of the device		°C	—
C _L	Output load capacitance	100		nF	1, 2

1. C_L must be connected to VREF_OUT if the VREF_OUT functionality is being used for either an internal or external reference.
2. The load capacitance should not exceed +/-25% of the nominal specified C_L value over the operating temperature range of the device.

Table 30. VREF full-range operating behaviors

Symbol	Description	Min.	Typ.	Max.	Unit	Notes
V _{out}	Voltage reference output with factory trim at nominal V _{DDA} and temperature=25°C	1.190	1.195	1.2	V	1
		2.092	2.1	2.108	V	
V _{out}	Voltage reference 1.2 V output— factory trim	1.188	1.195	1.202	V	1
	Voltage reference 2.1 V output — factory trim	2.087	2.1	2.113	V	1
V _{step}	Voltage reference trim step for 1.2 V output	—	0.5	—	mV	1
	Voltage reference trim step for 2.1 V output	—	1.5	—	mV	1
Ac	Aging coefficient	—	—	400	uV/yr	—
I _{bg}	Bandgap only current	—	60	80	μA	1
I _{lp}	Low-power buffer current	—	180	360	μA	1
I _{hp}	High-power buffer current	—	480	960	μA	1
ΔV _{LOAD}	Load regulation — current is ± 1.0 mA	—	±0.2	—	mV	1, 2
T _{stup}	Buffer startup time	—	—	100	μs	—
V _{vdrift}	Voltage drift for 1.2 V output (V _{max} -V _{min} across the full voltage range)	—	0.5	2	mV	1
	Voltage drift for 2.1 V output (V _{max} -V _{min} across the full voltage range)	—	0.9	3.5	mV	
V _{tdrift}	Temperature drift for 1.2 V output (V _{max} -V _{min} across the full temperature range)	—	2	15	mV	3
	Temperature drift for 2.1 V output (V _{max} -V _{min} across the full temperature range)	—	3.5	26	mV	

1. See the chip's Reference Manual for the appropriate settings of the VREF Status and Control register for V_{out} selection of 1.2 V or 2.1 V.
2. Load regulation voltage is the difference between the VREF_OUT voltage with no load vs. voltage with defined load
3. To get best performance of VREF temperature drift, VREF_SC[ICOMPEN] must be set.

Table 31. VREF limited-range operating requirements

Symbol	Description	Min.	Max.	Unit	Notes
T _A	Temperature	0	50	°C	—

Table 32. VREF limited-range operating behaviors

Symbol	Description	Min.	Max.	Unit	Notes
V _{out}	Voltage reference output 1.2 V with factory trim	1.173	1.225	V	—
V _{out}	Voltage reference output 2.1 V with factory trim	2.088	2.115	V	—

3.6.3 CMP and 6-bit DAC electrical specifications

Table 33. Comparator and 6-bit DAC electrical specifications

Symbol	Description	Min.	Typ.	Max.	Unit
V _{DD}	Supply voltage	1.71	—	3.6	V
I _{DDHS}	Supply current, High-speed mode (EN=1, PMODE=1)	—	—	200	μA
I _{DDL}	Supply current, low-speed mode (EN=1, PMODE=0)	—	—	20	μA
V _{AIN}	Analog input voltage	V _{SS} – 0.3	—	V _{DD}	V
V _{AIO}	Analog input offset voltage	—	—	20	mV
V _H	Analog comparator hysteresis ¹ <ul style="list-style-type: none"> • CR0[HYSTCTR] = 00 • CR0[HYSTCTR] = 01 • CR0[HYSTCTR] = 10 • CR0[HYSTCTR] = 11 	—	5 10 20 30	—	mV mV mV mV
V _{CMPOh}	Output high	V _{DD} – 0.5	—	—	V
V _{CMPOl}	Output low	—	—	0.5	V
t _{DHS}	Propagation delay, high-speed mode (EN=1, PMODE=1)	20	50	200	ns
t _{DLS}	Propagation delay, low-speed mode (EN=1, PMODE=0)	80	250	600	ns
	Analog comparator initialization delay ²	—	—	40	μs
I _{DAC6b}	6-bit DAC current adder (enabled)	—	7	—	μA
INL	6-bit DAC integral non-linearity	–0.5	—	0.5	LSB ³
DNL	6-bit DAC differential non-linearity	–0.3	—	0.3	LSB

1. Typical hysteresis is measured with input voltage range limited to 0.6 to V_{DD}–0.6 V.
2. Comparator initialization delay is defined as the time between software writes to change control inputs (Writes to CMP_DACCR[DACEN], CMP_DACCR[VRSEL], CMP_DACCR[VOSEL], CMP_MUXCR[PSEL], and CMP_MUXCR[MSEL]) and the comparator output settling to a stable level.
3. 1 LSB = V_{reference}/64

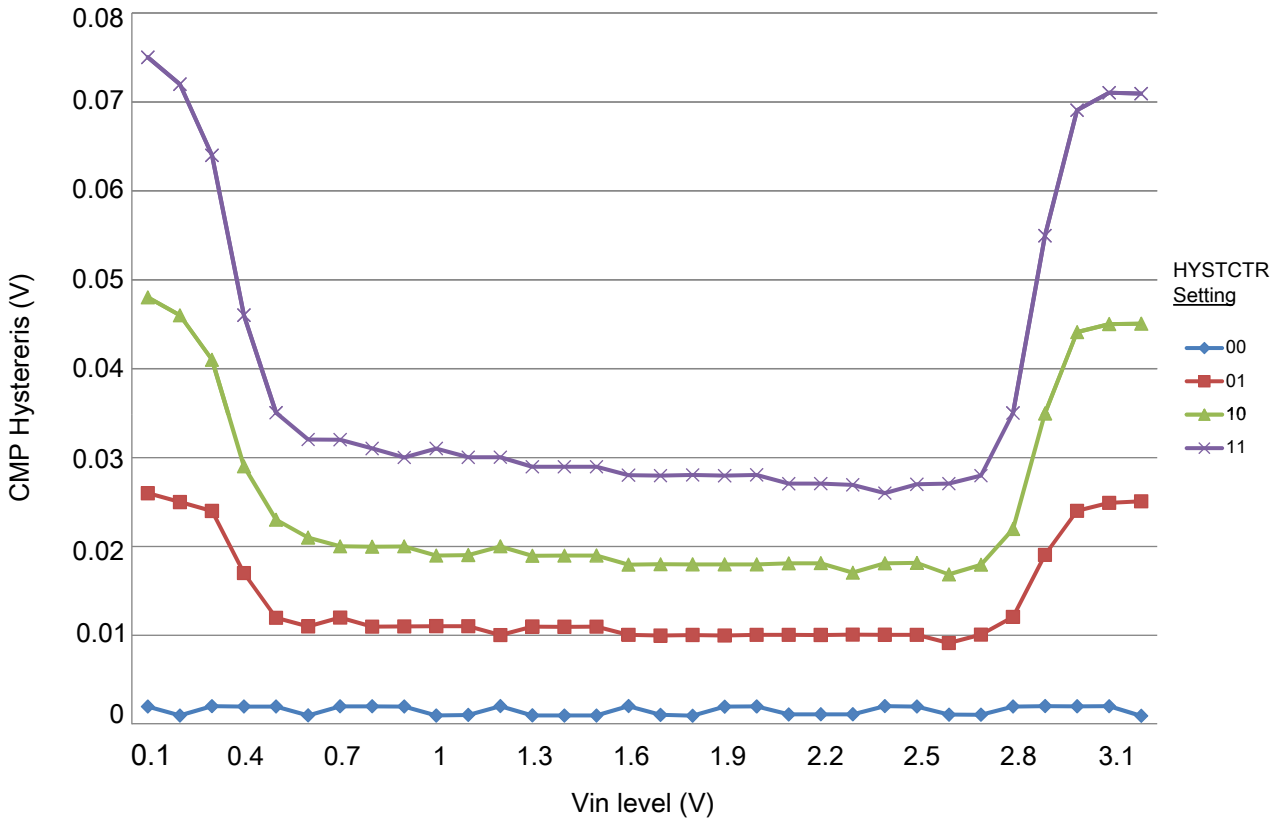

Figure 10. Typical hysteresis vs. Vin level (VDD = 3.3 V, PMODE = 0)

ADC electrical specifications

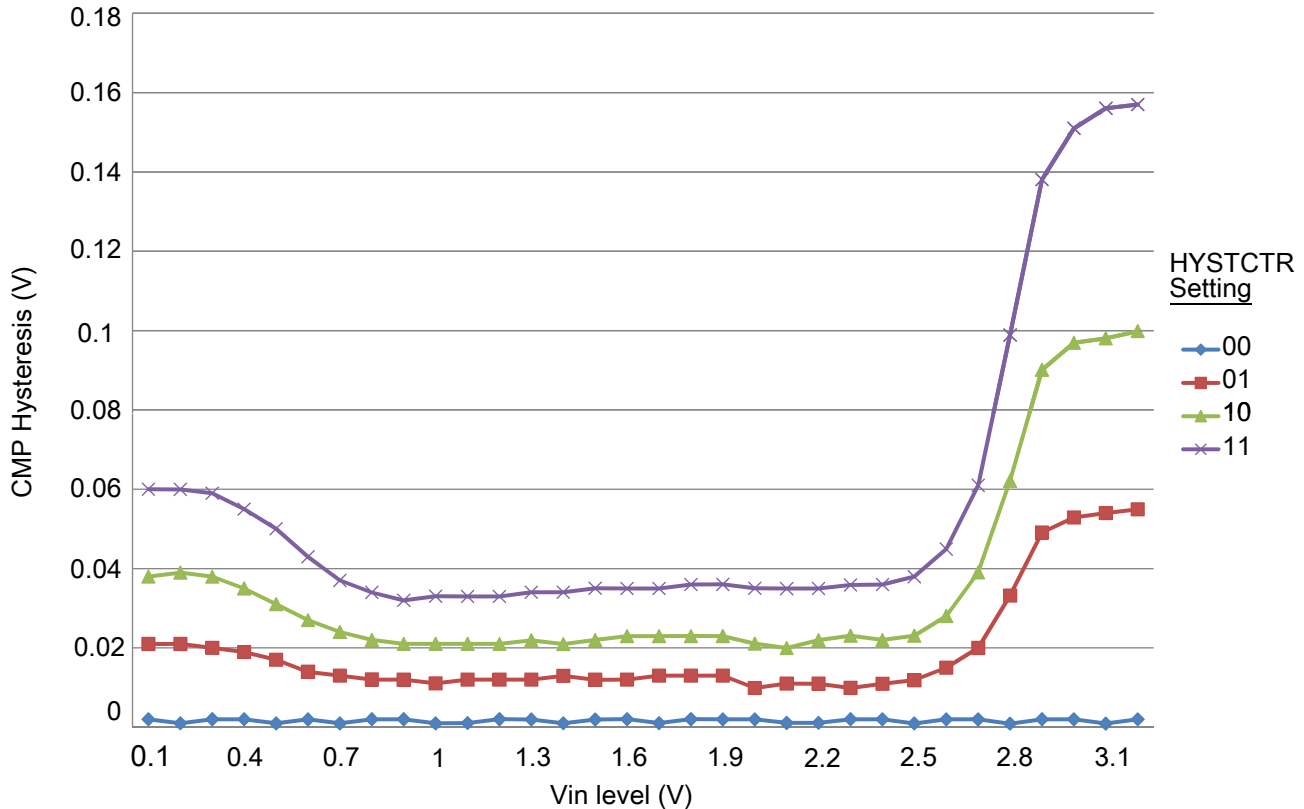

Figure 11. Typical hysteresis vs. Vin level (VDD = 3.3 V, PMODE = 1)

3.6.4 12-bit DAC electrical characteristics

3.6.4.1 12-bit DAC operating requirements

Table 34. 12-bit DAC operating requirements

Symbol	Description	Min.	Max.	Unit	Notes
V_{DDA}	Supply voltage		3.6	V	
V_{DACR}	Reference voltage	1.13	3.6	V	1
C_L	Output load capacitance	—	100	pF	2
I_L	Output load current	—	1	mA	

1. The DAC reference can be selected to be V_{DDA} or V_{REFH} .
2. A small load capacitance (47 pF) can improve the bandwidth performance of the DAC.

3.6.4.2 12-bit DAC operating behaviors

Table 35. 12-bit DAC operating behaviors

Symbol	Description	Min.	Typ.	Max.	Unit	Notes
I_{DDA_DACLP}	Supply current — low-power mode	—	—	250	μA	
I_{DDA_DACHP}	Supply current — high-speed mode	—	—	900	μA	
t_{DACLP}	Full-scale settling time (0x080 to 0xF7F) — low-power mode	—	100	200	μs	1
t_{DACHP}	Full-scale settling time (0x080 to 0xF7F) — high-power mode	—	15	30	μs	1
$t_{CCDACLP}$	Code-to-code settling time (0xBF8 to 0xC08) — low-power mode and high-speed mode	—	0.7	1	μs	1
$V_{dacoutl}$	DAC output voltage range low — high-speed mode, no load, DAC set to 0x000	—	—	100	mV	
$V_{dacouth}$	DAC output voltage range high — high-speed mode, no load, DAC set to 0xFFFF	$V_{DACR} - 100$	—	V_{DACR}	mV	
INL	Integral non-linearity error — high speed mode	—	—	± 8	LSB	2
DNL	Differential non-linearity error — $V_{DACR} > 2\text{ V}$	—	—	± 1	LSB	3
DNL	Differential non-linearity error — $V_{DACR} = V_{REF_OUT}$	—	—	± 1	LSB	4
V_{OFFSET}	Offset error	—	± 0.4	± 0.8	%FSR	5
E_G	Gain error	—	± 0.1	± 0.6	%FSR	5
PSRR	Power supply rejection ratio, $V_{DDA} \geq 2.4\text{ V}$	60	—	90	dB	
T_{CO}	Temperature coefficient offset voltage	—	3.7	—	$\mu\text{V}/\text{C}$	6
T_{GE}	Temperature coefficient gain error	—	0.000421	—	%FSR/C	
R_{op}	Output resistance (load = 3 k Ω)	—	—	250	Ω	
SR	Slew rate -80h→ F7Fh→ 80h <ul style="list-style-type: none"> High power (SP_{HP}) Low power (SP_{LP}) 	1.2 0.05	1.7 0.12	— —	$\text{V}/\mu\text{s}$	
BW	3dB bandwidth <ul style="list-style-type: none"> High power (SP_{HP}) Low power (SP_{LP}) 	550 40	— —	— —	kHz	

- Settling within ± 1 LSB
- The INL is measured for 0 + 100 mV to $V_{DACR} - 100$ mV
- The DNL is measured for 0 + 100 mV to $V_{DACR} - 100$ mV
- The DNL is measured for 0 + 100 mV to $V_{DACR} - 100$ mV with $V_{DDA} > 2.4\text{ V}$
- Calculated by a best fit curve from $V_{SS} + 100$ mV to $V_{DACR} - 100$ mV
- $V_{DDA} = 3.0\text{ V}$, reference select set for V_{DDA} ($DACx_CO:DACRFS = 1$), high power mode ($DACx_CO:LPEN = 0$), DAC set to 0x800, temperature range is across the full range of the device

ADC electrical specifications

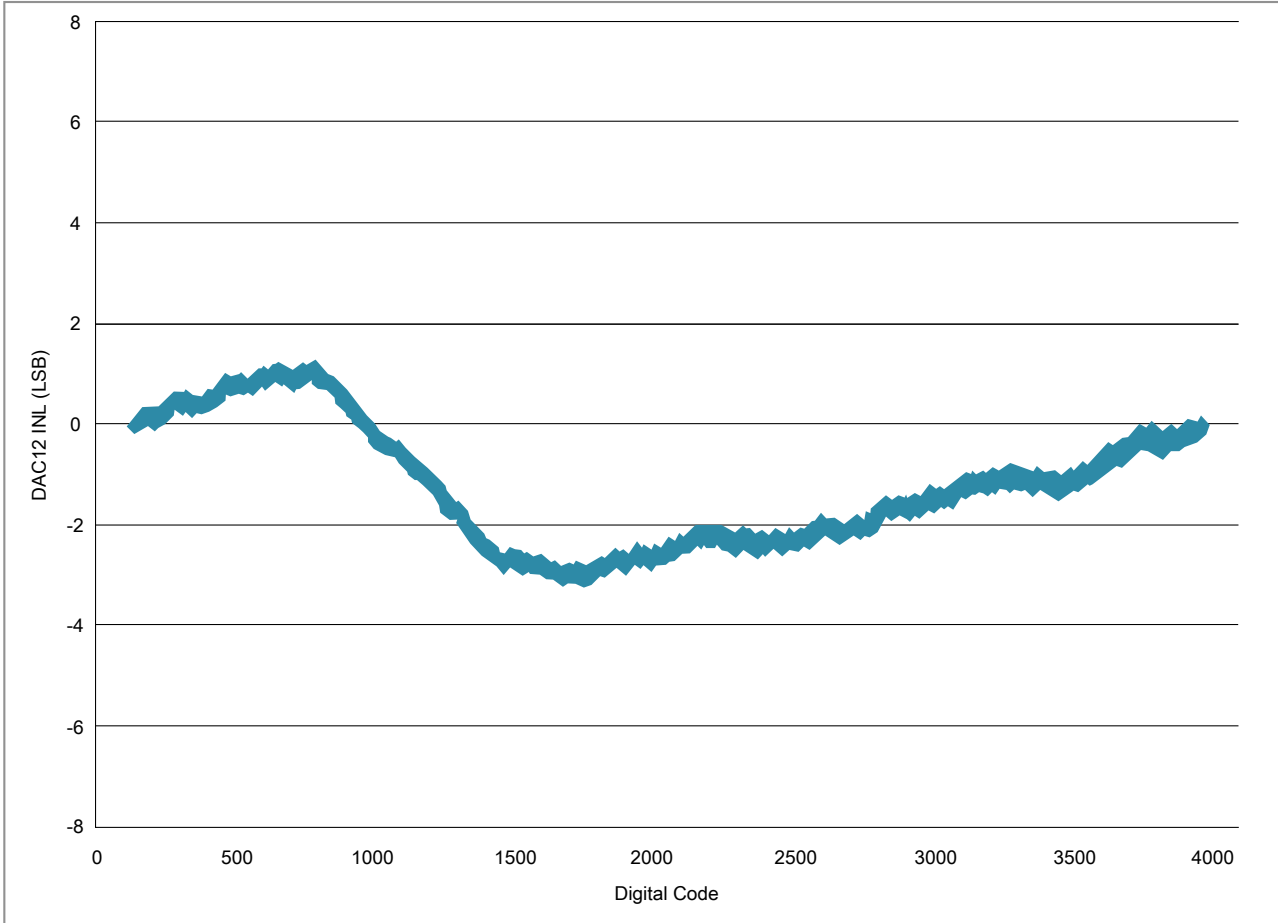

Figure 12. Typical INL error vs. digital code

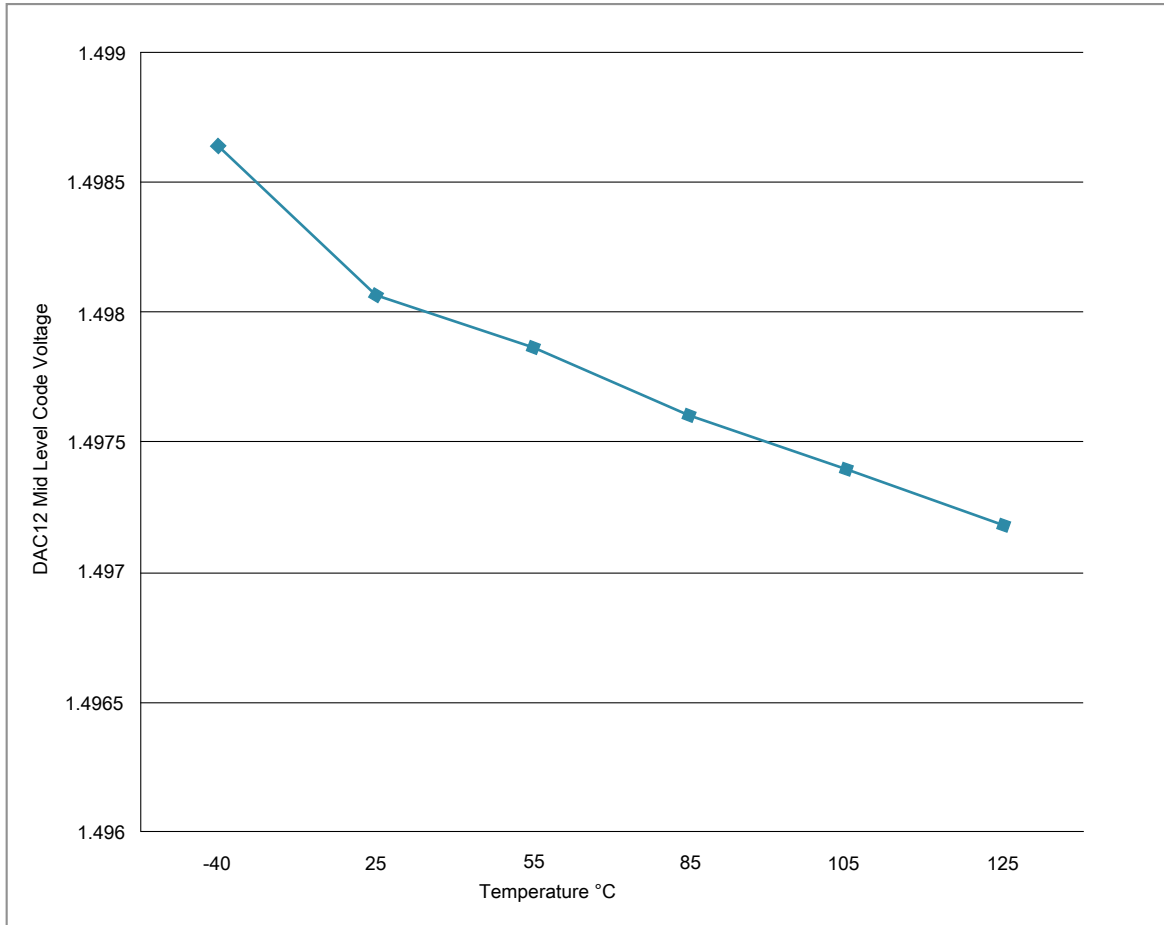

Figure 13. Offset at half scale vs. temperature

3.7 Timers

See [General switching specifications](#).

3.8 Communication interfaces

3.8.1 EMV SIM specifications

Each EMV SIM module interface consists of a total of five pins.

The interface is designed to be used with synchronous Smart cards, meaning the EMV SIM module provides the clock used by the Smart card. The clock frequency is typically 372 times the Tx/Rx data rate; however, the EMV SIM module can also work with CLK frequencies of 16 times the Tx/Rx data rate.

There is no timing relationship between the clock and the data. The clock that the EMV SIM module provides to the Smart card is used by the Smart card to recover the clock from the data in the same manner as standard UART data exchanges. All five signals of the EMV SIM module are asynchronous with each other.

There are no required timing relationships between signals in normal mode. The smart card is initiated by the interface device; the Smart card responds with Answer to Reset. Although the EMV SIM interface has no defined requirements, the ISO/IEC 7816 defines reset and power-down sequences (for detailed information see ISO/IEC 7816).

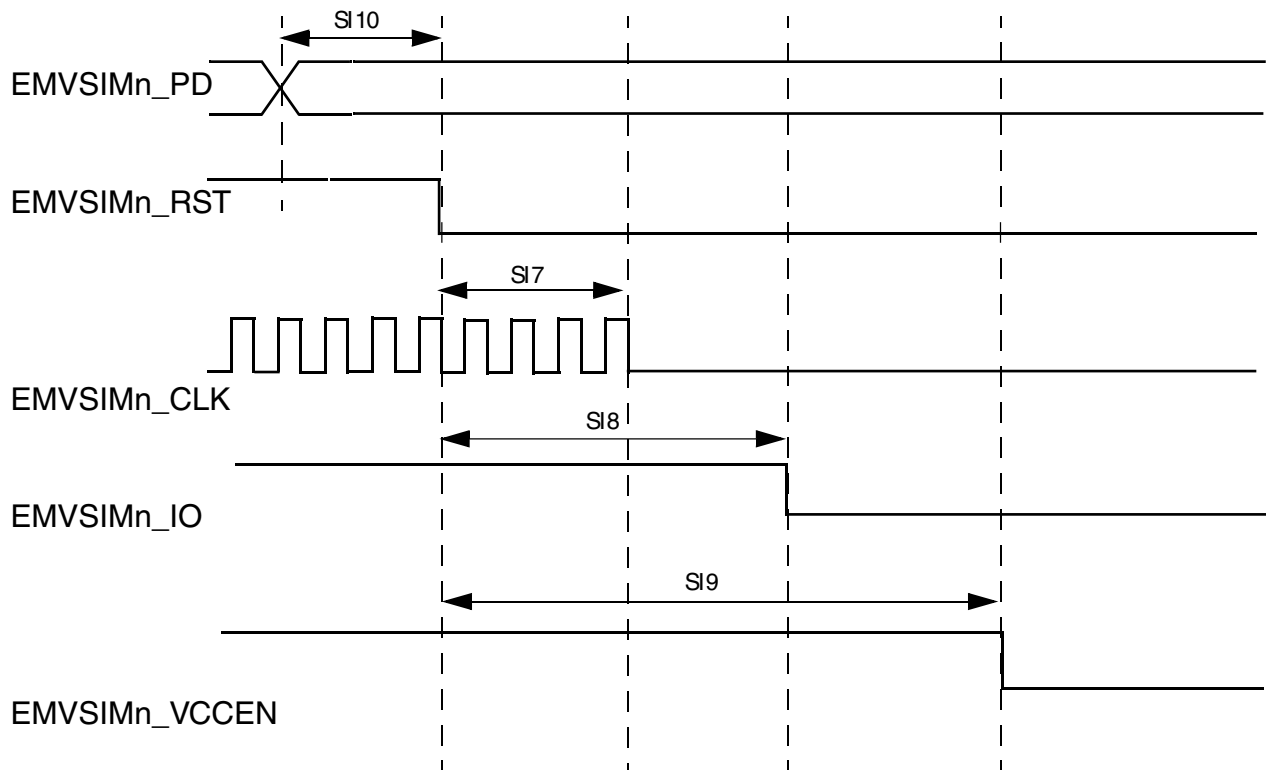

Figure 14. EMV SIM Clock Timing Diagram

The following table defines the general timing requirements for the EMV SIM interface.

Table 36. Timing Specifications, High Drive Strength

ID	Parameter	Symbol	Min	Max	Unit
SI 1	EMV SIM clock frequency (EMVSIMn_CLK) ¹	S _{freq}	1	5	MHz
SI 2	EMV SIM clock rise time (EMVSIMn_CLK) ²	S _{rise}	—	0.08 × (1/Sfreq)	ns
SI 3	EMV SIM clock fall time (EMVSIMn_CLK) ²	S _{fall}	—	0.08 × (1/Sfreq)	ns
SI 4	EMV SIM input transition time (EMVSIMn_IO, EMVSIMn_PD)	S _{tran}	20	25	ns
Si 5	EMV SIM I/O rise time / fall time (EMVSIMn_IO) ³	Tr/Tf	—	0.8	μs
Si 6	EMV SIM RST rise time / fall time (EMVSIMn_RST) ⁴	Tr/Tf	—	0.8	μs

1. 50% duty cycle clock,
2. With C = 50 pF
3. With C_{in} = 30 pF, C_{out} = 30 pF,
4. With C_{in} = 30 pF,

3.8.1.1 EMV SIM Reset Sequences

Smart cards may have internal reset, or active low reset. The following subset describes the reset sequences in these two cases.

3.8.1.1.1 Smart Cards with Internal Reset

Following figure shows the reset sequence for Smart cards with internal reset. The reset sequence comprises the following steps:

- After power-up, the clock signal is enabled on EMVSIMn_CLK (time T₀)
- After 200 clock cycles, EMVSIMn_IO must be asserted.
- The card must send a response on EMVSIMn_IO acknowledging the reset between 400–40000 clock cycles after T₀.

ADC electrical specifications

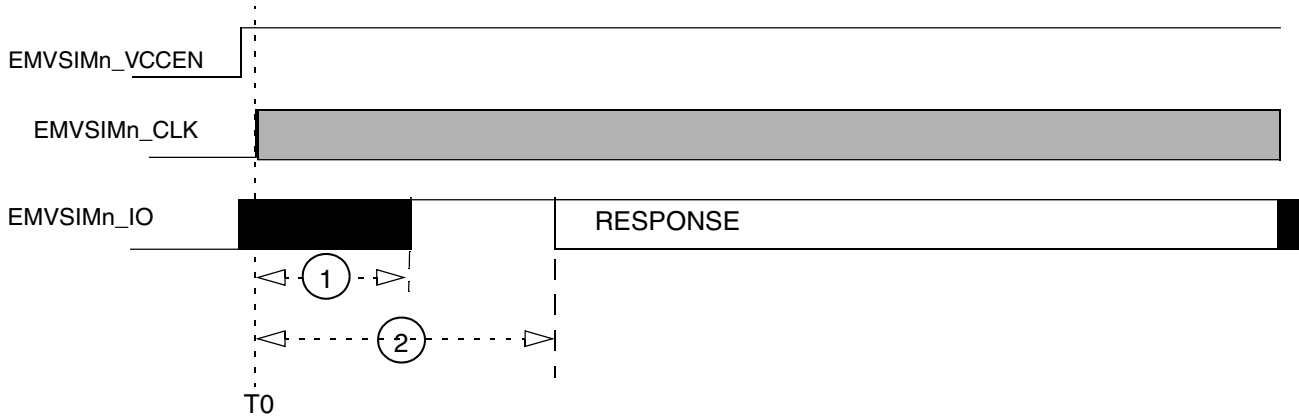

Figure 15. Internal Reset Card Reset Sequence

The following table defines the general timing requirements for the SIM interface.

Table 37. Timing Specifications, Internal Reset Card Reset Sequence

Ref	Min	Max	Units
1	—	200	EMVSiMx_CLK clock cycles
2	400	40,000	EMVSiMx_CLK clock cycles

3.8.1.1.2 Smart Cards with Active Low Reset

Following figure shows the reset sequence for Smart cards with active low reset. The reset sequence comprises the following steps::

- After power-up, the clock signal is enabled on EMVSiMn_CLK (time T0)
- After 200 clock cycles, EMVSiMn_IO must be asserted.
- EMVSiMn_RST must remain low for at least 40,000 clock cycles after T0 (no response is to be received on RX during those 40,000 clock cycles)
- EMVSiMn_RST is asserted (at time T1)
- EMVSiMn_RST must remain asserted for at least 40,000 clock cycles after T1, and a response must be received on EMVSiMn_IO between 400 and 40,000 clock cycles after T1.

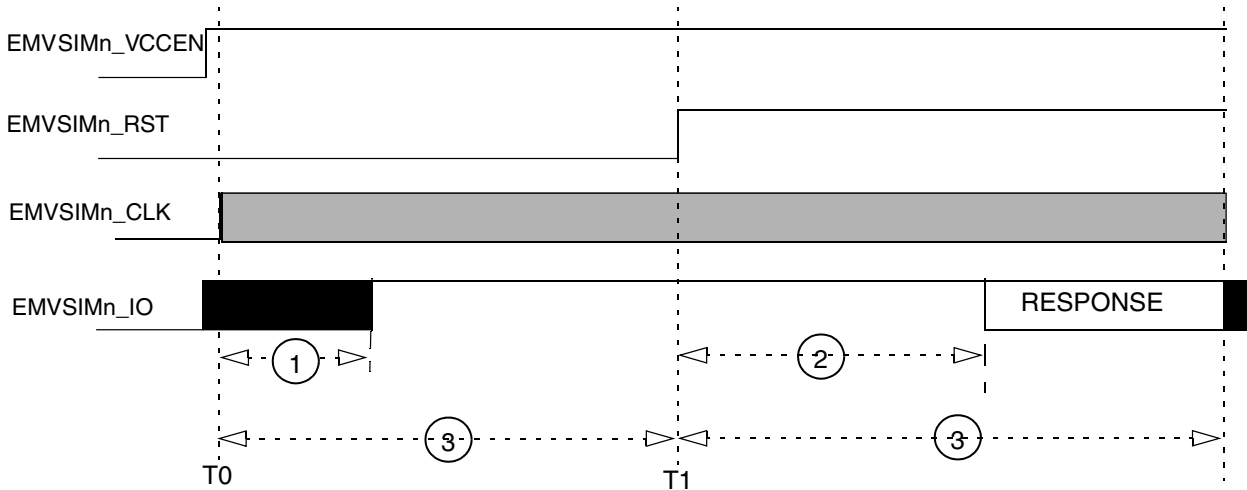

Figure 16. Active-Low-Reset Smart Card Reset Sequence

The following table defines the general timing requirements for the EMVSIM interface..

Table 38. Timing Specifications, Internal Reset Card Reset Sequence

Ref No	Min	Max	Units
1	—	200	EMVSIMx_CLK clock cycles
2	400	40,000	EMVSIMx_CLK clock cycles
3	40,000	—	EMVSIMx_CLK clock cycles

3.8.1.2 EMVSIM Power-Down Sequence

Following figure shows the EMV SIM interface power-down AC timing diagram. [Table 39](#) table shows the timing requirements for parameters (SI7–SI10) shown in the figure. The power-down sequence for the EMV SIM interface is as follows:

- EMVSIMn_SIMPD port detects the removal of the Smart Card
- EMVSIMn_RST is negated
- EMVSIMn_CLK is negated
- EMVSIMn_IO is negated
- EMVSIMx_VCCENy is negated

Each of the above steps requires one OSC32KCLK period (usually 32 kHz, also known as rtcclk in below figure). Power-down may be initiated by a Smart card removal detection; or it may be launched by the processor.

ADC electrical specifications

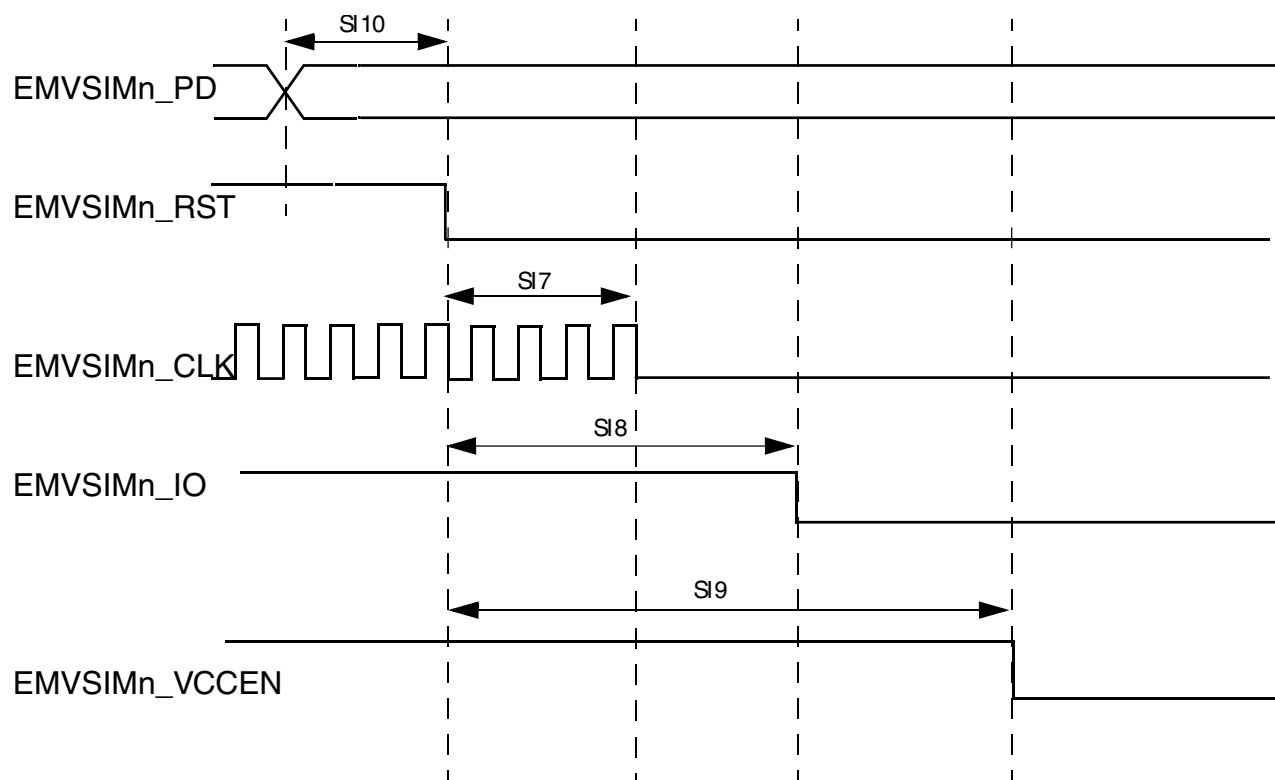

Figure 17. Smart Card Interface Power Down AC Timing

Table 39. Timing Requirements for Power-down Sequence

Ref No	Parameter	Symbol	Min	Max	Units
SI7	EMVSIM reset to SIM clock stop	$S_{rst2clk}$	$0.9 \times 1/Frtcclock^1$	$1.1 \times 1/Frtcclock$	μs
SI8	EMVSIM reset to SIM Tx data low	$S_{rst2dat}$	$1.8 \times 1/Frtcclock$	$2.2 \times 1/Frtcclock$	μs
SI9	EMVSIM reset to SIM voltage enable low	$S_{rst2ven}$	$2.7 \times 1/Frtcclock$	$3.3 \times 1/Frtcclock$	μs
SI10	EMVSIM presence detect to SIM reset low	S_{pd2rst}	$0.9 \times 1/Frtcclock$	$1.1 \times 1/Frtcclock$	μs

1. Frtcclk is OSC32KCLK, and this clock must be enabled during the power down sequence.

NOTE

Same timing is also followed when auto power down is initiated. See Reference Manual for reference.

3.8.2 USB electrical specifications

The USB electricals for the USB On-the-Go module conform to the standards documented by the Universal Serial Bus Implementers Forum. For the most up-to-date standards, visit usb.org.

NOTE

The Fast IRC do not meet the USB jitter specifications for certification for Host mode operation.

3.8.3 USB VREG electrical specifications

Table 40. USB VREG electrical specifications

Symbol	Description	Min.	Typ. ¹	Max.	Unit	Notes
VREGIN	Input supply voltage	2.7	—	5.5	V	
I _{DDon}	Quiescent current — Run mode, load current equal zero, input supply (VREGIN) > 3.6 V	—	125	186	μA	
I _{DDstby}	Quiescent current — Standby mode, load current equal zero	—	1.1	10	μA	
I _{DDoff}	Quiescent current — Shutdown mode <ul style="list-style-type: none"> VREGIN = 5.0 V and temperature=25 °C Across operating voltage and temperature 	—	650	—	nA	
		—	—	4	μA	
I _{LOADrun}	Maximum load current — Run mode	—	—	120	mA	
I _{LOADstby}	Maximum load current — Standby mode	—	—	1	mA	
V _{Reg33out}	Regulator output voltage — Input supply (VREGIN) > 3.6 V <ul style="list-style-type: none"> Run mode Standby mode 	3	3.3	3.6	V	
		2.1	2.8	3.6	V	
V _{Reg33out}	Regulator output voltage — Input supply (VREGIN) < 3.6 V, pass-through mode	2.1	—	3.6	V	2
C _{OUT}	External output capacitor	1.76	2.2	8.16	μF	
ESR	External output capacitor equivalent series resistance	1	—	100	mΩ	
I _{LIM}	Short circuit current	—	290	—	mA	

1. Typical values assume VREGIN = 5.0 V, Temp = 25 °C unless otherwise stated.

2. Operating in pass-through mode: regulator output voltage equal to the input voltage minus a drop proportional to I_{Load}.

3.8.4 LPSPI switching specifications

The Low Power Serial Peripheral Interface (LPSPI) provides a synchronous serial bus with master and slave operations. Many of the transfer attributes are programmable. The following tables provide timing characteristics for classic SPI timing modes.

All timing is shown with respect to 20% V_{DD} and 80% V_{DD} thresholds, unless noted, as well as input signal transitions of 3 ns and a 30 pF maximum load on all LPSPI pins.

NOTE

- Slew rate disabled pads are those pins with PORTx_PCRn[SRE] bit cleared. Slew rate enabled pads are those pins with PORTx_PCRn[SRE] bit set.
- To achieve high bit rate, it is recommended to use fast pins (PTE20, PTE21, PTE22, PTE23, PTD4, PTD5, PTD6, and PTD7) and/or high drive pins (PTC3, PTC4, PTD4, PTD5, PTD6, and PTD7).

Table 41. LPSPI master mode timing on slew rate disabled pads

Num.	Symbol	Description	Min.	Max.	Unit	Note
1	f_{op}	Frequency of operation	$f_{periph}/2048$	$f_{periph}/2$	Hz	1
2	t_{SPSCK}	SPSCK period	$2 \times t_{periph}$	$2048 \times t_{periph}$	ns	2
3	t_{Lead}	Enable lead time	1/2	—	t_{SPSCK}	—
4	t_{Lag}	Enable lag time	1/2	—	t_{SPSCK}	—
5	t_{WSPSCK}	Clock (SPSCK) high or low time	$t_{periph} - 30$	$1024 \times t_{periph}$	ns	—
6	t_{SU}	Data setup time (inputs)	18	—	ns	—
7	t_{HI}	Data hold time (inputs)	0	—	ns	—
8	t_v	Data valid (after SPSCK edge)	—	15	ns	—
9	t_{HO}	Data hold time (outputs)	0	—	ns	—
10	t_{RI}	Rise time input	—	$t_{periph} - 25$	ns	—
	t_{FI}	Fall time input				
11	t_{RO}	Rise time output	—	25	ns	—
	t_{FO}	Fall time output				

1. f_{periph} is the LPSPI peripheral functional clock.
2. $t_{periph} = 1/f_{periph}$

Table 42. LPSPI master mode timing on slew rate enabled pads

Num.	Symbol	Description	Min.	Max.	Unit	Note
1	f_{op}	Frequency of operation	$f_{periph}/2048$	$f_{periph}/2$	Hz	1

Table continues on the next page...

Table 42. LPSPI master mode timing on slew rate enabled pads (continued)

Num.	Symbol	Description	Min.	Max.	Unit	Note
2	t_{SPSCK}	SPSCK period	$2 \times t_{periph}$	$2048 \times t_{periph}$	ns	2
3	t_{Lead}	Enable lead time	1/2	—	t_{SPSCK}	—
4	t_{Lag}	Enable lag time	1/2	—	t_{SPSCK}	—
5	t_{WSPSCK}	Clock (SPSCK) high or low time	$t_{periph} - 30$	$1024 \times t_{periph}$	ns	—
6	t_{SU}	Data setup time (inputs)	96	—	ns	—
7	t_{HI}	Data hold time (inputs)	0	—	ns	—
8	t_v	Data valid (after SPSCK edge)	—	52	ns	—
9	t_{HO}	Data hold time (outputs)	0	—	ns	—
10	t_{RI}	Rise time input	—	$t_{periph} - 25$	ns	—
	t_{FI}	Fall time input				
11	t_{RO}	Rise time output	—	36	ns	—
	t_{FO}	Fall time output				

- f_{periph} is the LPSPI peripheral functional clock
- $t_{periph} = 1/f_{periph}$

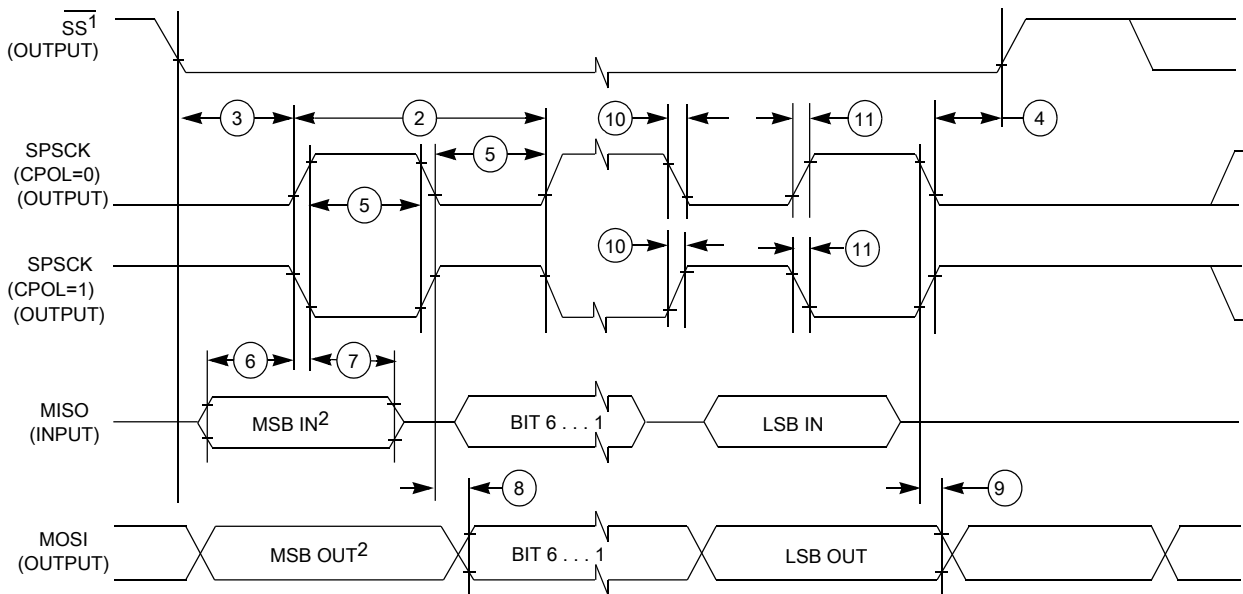

- If configured as an output.
- LSBF = 0. For LSBF = 1, bit order is LSB, bit 1, ..., bit 6, MSB.

Figure 18. LPSPI master mode timing (CPHA = 0)

ADC electrical specifications

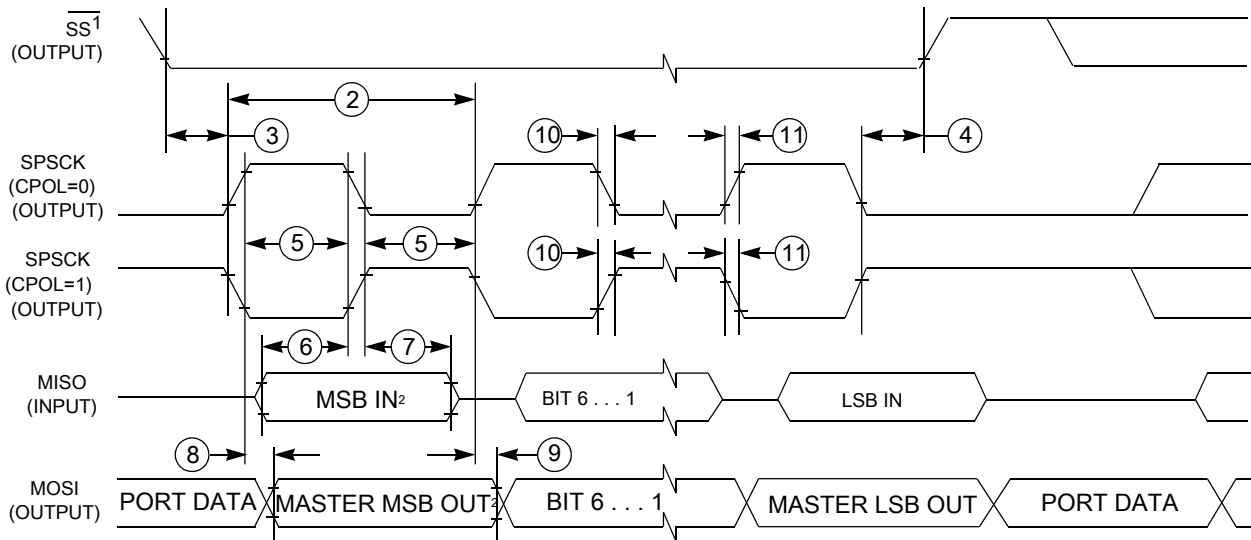

1. If configured as output
2. LSBF = 0. For LSBF = 1, bit order is LSB, bit 1, ..., bit 6, MSB.

Figure 19. LPSPI master mode timing (CPHA = 1)

Table 43. LPSPI slave mode timing on slew rate disabled pads

Num.	Symbol	Description	Min.	Max.	Unit	Note
1	f_{op}	Frequency of operation	0	$f_{periph}/4$	Hz	1
2	t_{SPSCK}	SPSCK period	$4 \times t_{periph}$	—	ns	2
3	t_{Lead}	Enable lead time	1	—	t_{periph}	—
4	t_{Lag}	Enable lag time	1	—	t_{periph}	—
5	t_{WSPSCK}	Clock (SPSCK) high or low time	$t_{periph} - 30$	—	ns	—
6	t_{SU}	Data setup time (inputs)	2.5	—	ns	—
7	t_{HI}	Data hold time (inputs)	3.5	—	ns	—
8	t_a	Slave access time	—	t_{periph}	ns	3
9	t_{dis}	Slave MISO disable time	—	t_{periph}	ns	4
10	t_v	Data valid (after SPSCK edge)	—	31	ns	—
11	t_{HO}	Data hold time (outputs)	0	—	ns	—
12	t_{RI}	Rise time input	—	$t_{periph} - 25$	ns	—
	t_{FI}	Fall time input				
13	t_{RO}	Rise time output	—	25	ns	—
	t_{FO}	Fall time output				

1. f_{periph} is the LPSPI peripheral functional clock
2. $t_{periph} = 1/f_{periph}$
3. Time to data active from high-impedance state
4. Hold time to high-impedance state

Table 44. LPSPI slave mode timing on slew rate enabled pads

Num.	Symbol	Description	Min.	Max.	Unit	Note
1	f_{op}	Frequency of operation	0	$f_{periph}/4$	Hz	1
2	t_{SPSCK}	SPSCK period	$4 \times t_{periph}$	—	ns	2
3	t_{Lead}	Enable lead time	1	—	t_{periph}	—
4	t_{Lag}	Enable lag time	1	—	t_{periph}	—
5	t_{WSPSCK}	Clock (SPSCK) high or low time	$t_{periph} - 30$	—	ns	—
6	t_{SU}	Data setup time (inputs)	2	—	ns	—
7	t_{HI}	Data hold time (inputs)	7	—	ns	—
8	t_a	Slave access time	—	t_{periph}	ns	3
9	t_{dis}	Slave MISO disable time	—	t_{periph}	ns	4
10	t_v	Data valid (after SPSCK edge)	—	122	ns	—
11	t_{HO}	Data hold time (outputs)	0	—	ns	—
12	t_{RI}	Rise time input	—	$t_{periph} - 25$	ns	—
	t_{FI}	Fall time input				
13	t_{RO}	Rise time output	—	36	ns	—
	t_{FO}	Fall time output				

1. f_{periph} is the LPSPI peripheral functional clock
2. $t_{periph} = 1/f_{periph}$
3. Time to data active from high-impedance state
4. Hold time to high-impedance state

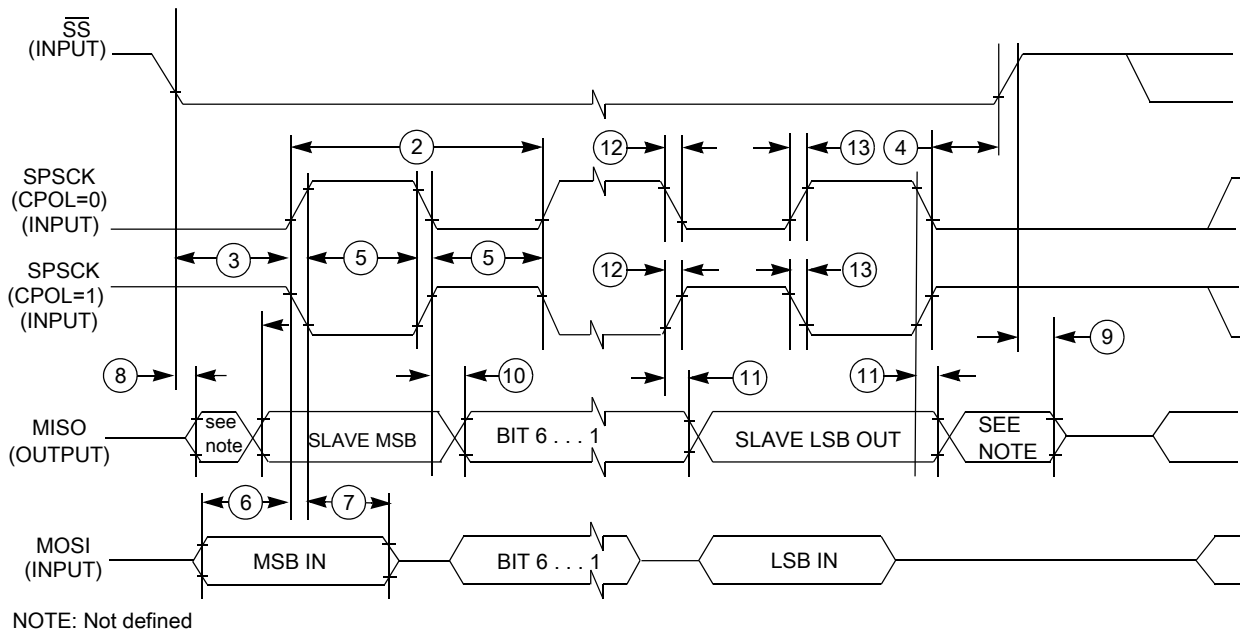

Figure 20. LPSPI slave mode timing (CPHA = 0)

ADC electrical specifications

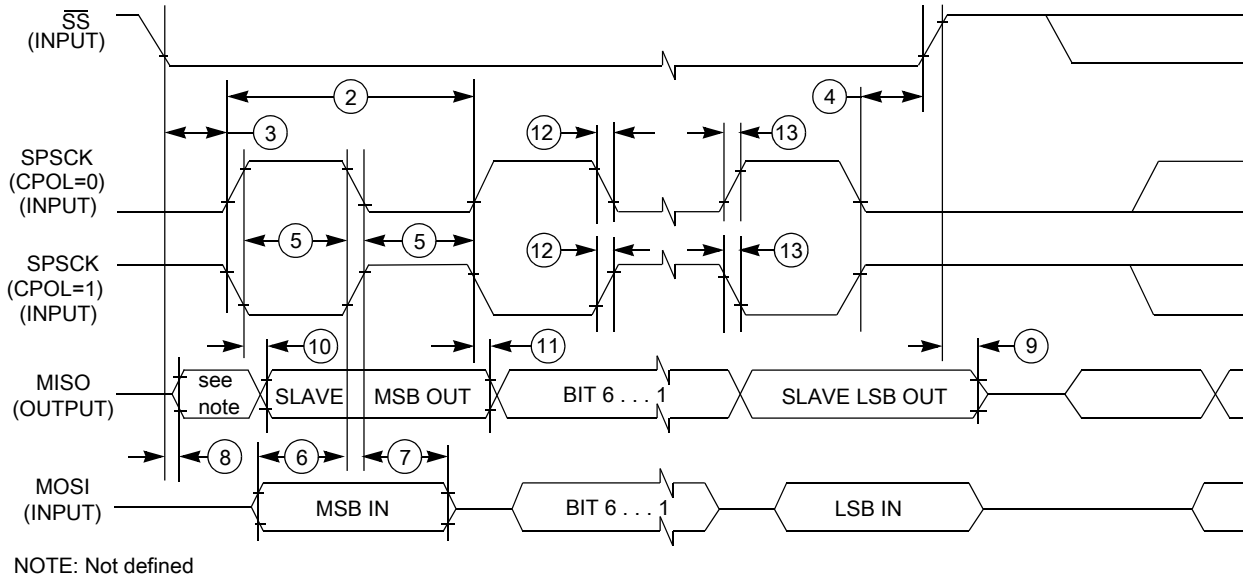

Figure 21. LPSPI slave mode timing (CPHA = 1)

3.8.5 LPI²C

Table 45. LPI²C specifications

Symbol	Description		Min.	Max.	Unit	Notes
f _{SCL}	SCL clock frequency	Standard mode (Sm)	0	100	kHz	1
		Fast mode (Fm)	0	400		1, 2
		Fast mode Plus (Fm+)	0	1000		1, 3
		Ultra Fast mode (UFm)	0	5000		1, 4
		High speed mode (Hs-mode)	0	3400		1, 5

1. See [General switching specifications](#), measured at room temperature.
2. Measured with the maximum bus loading of 400pF at 3.3V VDD with pull-up R_p = 580Ω on normal drive pins or 350Ω on high drive pins, and at 1.8V VDD with R_p = 880Ω. For all other cases, select appropriate R_p per I2C Bus Specification and the pin drive capability.
3. Fm+ is only supported on high drive pin with high drive enabled. It is measured with the maximum bus loading of 400pF at 3.3V VDD with R_p = 350Ω. For all other cases, select appropriate R_p per I2C Bus Specification and the pin drive capability.
4. UFm is only supported on high drive pin with high drive enabled and push-pull output only mode. It is measured at 3.3V VDD with the maximum bus loading of 400pF. For 1.8V VDD, the maximum speed is 4Mbps.
5. Hs-mode is only supported in slave mode and on the high drive pins with high drive enabled.

3.8.6 LPUART

See [General switching specifications](#).

3.8.7 I2S/SAI switching specifications

This section provides the AC timing for the I2S/SAI module in master mode (clocks are driven) and slave mode (clocks are input). All timing is given for noninverted serial clock polarity (TCR2[BCP] is 0, RCR2[BCP] is 0) and a noninverted frame sync (TCR4[FSP] is 0, RCR4[FSP] is 0). If the polarity of the clock and/or the frame sync have been inverted, all the timing remains valid by inverting the bit clock signal (BCLK) and/or the frame sync (FS) signal shown in the following figures.

3.8.7.1 Normal Run, Wait and Stop mode performance over the full operating voltage range

This section provides the operating performance over the full operating voltage for the device in Normal Run, Wait and Stop modes.

Table 46. I2S/SAI master mode timing

Num.	Characteristic	Min.	Max.	Unit
	Operating voltage	1.71	3.6	V
S1	I2S_MCLK cycle time	40	—	ns
S2	I2S_MCLK (as an input) pulse width high/low	45%	55%	MCLK period
S3	I2S_TX_BCLK/I2S_RX_BCLK cycle time (output)	80	—	ns
S4	I2S_TX_BCLK/I2S_RX_BCLK pulse width high/low	45%	55%	BCLK period
S5	I2S_TX_BCLK/I2S_RX_BCLK to I2S_TX_FS/ I2S_RX_FS output valid	—	15.5	ns
S6	I2S_TX_BCLK/I2S_RX_BCLK to I2S_TX_FS/ I2S_RX_FS output invalid	0	—	ns
S7	I2S_TX_BCLK to I2S_TXD valid	—	19	ns
S8	I2S_TX_BCLK to I2S_TXD invalid	0	—	ns
S9	I2S_RXD/I2S_RX_FS input setup before I2S_RX_BCLK	26	—	ns
S10	I2S_RXD/I2S_RX_FS input hold after I2S_RX_BCLK	0	—	ns

ADC electrical specifications

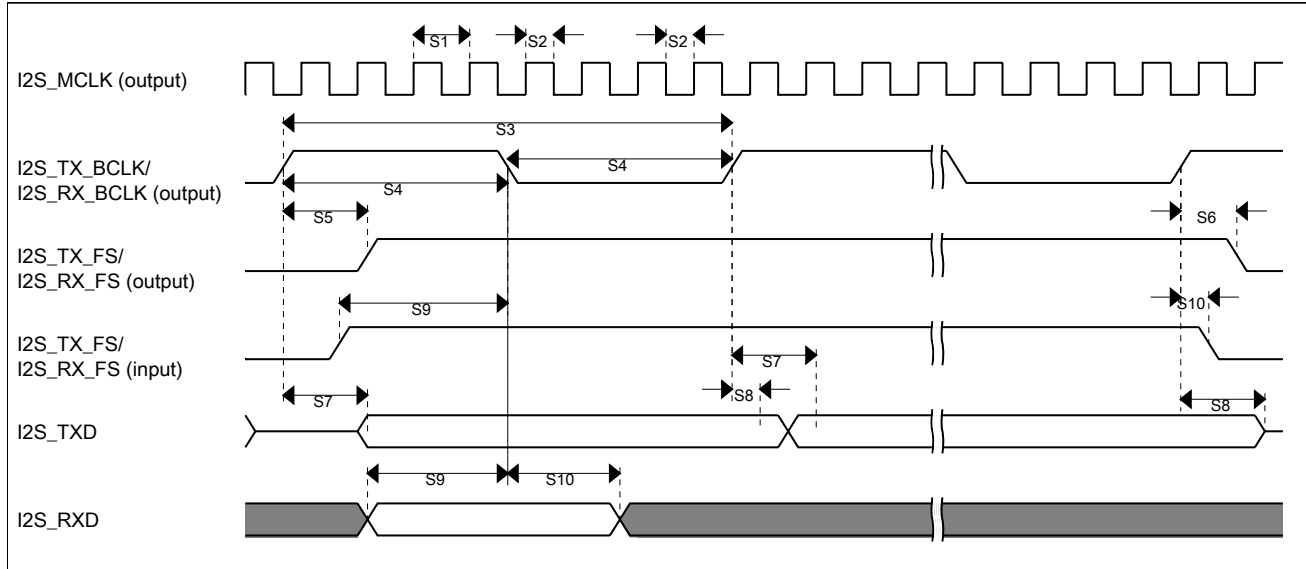

Figure 22. I2S/SAI timing — master modes

Table 47. I2S/SAI slave mode timing

Num.	Characteristic	Min.	Max.	Unit
	Operating voltage	1.71	3.6	V
S11	I2S_TX_BCLK/I2S_RX_BCLK cycle time (input)	80	—	ns
S12	I2S_TX_BCLK/I2S_RX_BCLK pulse width high/low (input)	45%	55%	MCLK period
S13	I2S_TX_FS/I2S_RX_FS input setup before I2S_TX_BCLK/I2S_RX_BCLK	10	—	ns
S14	I2S_TX_FS/I2S_RX_FS input hold after I2S_TX_BCLK/I2S_RX_BCLK	2	—	ns
S15	I2S_TX_BCLK to I2S_TXD/I2S_TX_FS output valid	—	33	ns
S16	I2S_TX_BCLK to I2S_TXD/I2S_TX_FS output invalid	0	—	ns
S17	I2S_RXD setup before I2S_RX_BCLK	10	—	ns
S18	I2S_RXD hold after I2S_RX_BCLK	2	—	ns
S19	I2S_TX_FS input assertion to I2S_TXD output valid ¹	—	28	ns

1. Applies to first bit in each frame and only if the TCR4[FSE] bit is clear

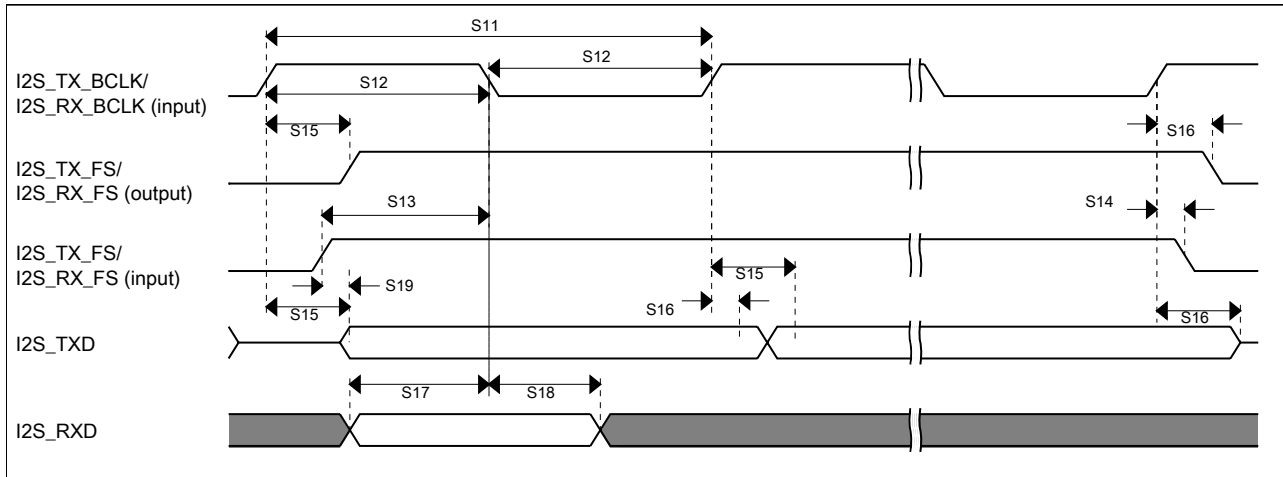

Figure 23. I2S/SAI timing — slave modes

3.8.7.2 VLPR, VLPW, and VLPS mode performance over the full operating voltage range

This section provides the operating performance over the full operating voltage for the device in VLPR, VLPW, and VLPS modes.

Table 48. I2S/SAI master mode timing in VLPR, VLPW, and VLPS modes (full voltage range)

Num.	Characteristic	Min.	Max.	Unit
	Operating voltage	1.71	3.6	V
S1	I2S_MCLK cycle time	62.5	—	ns
S2	I2S_MCLK pulse width high/low	45%	55%	MCLK period
S3	I2S_TX_BCLK/I2S_RX_BCLK cycle time (output)	250	—	ns
S4	I2S_TX_BCLK/I2S_RX_BCLK pulse width high/low	45%	55%	BCLK period
S5	I2S_TX_BCLK/I2S_RX_BCLK to I2S_TX_FS/ I2S_RX_FS output valid	—	45	ns
S6	I2S_TX_BCLK/I2S_RX_BCLK to I2S_TX_FS/ I2S_RX_FS output invalid		—	ns
S7	I2S_TX_BCLK to I2S_TXD valid	—	45	ns
S8	I2S_TX_BCLK to I2S_TXD invalid		—	ns
S9	I2S_RXD/I2S_RX_FS input setup before I2S_RX_BCLK		—	ns
S10	I2S_RXD/I2S_RX_FS input hold after I2S_RX_BCLK	0	—	ns

ADC electrical specifications

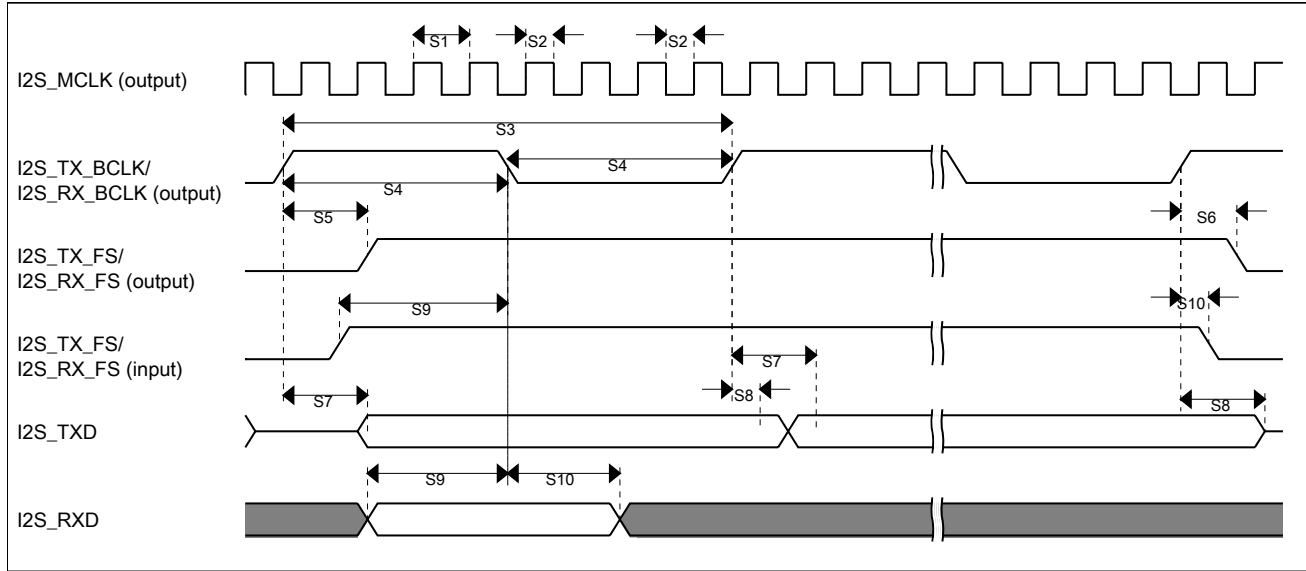

Figure 24. I2S/SAI timing — master modes

Table 49. I2S/SAI slave mode timing in VLPR, VLPW, and VLPS modes (full voltage range)

Num.	Characteristic	Min.	Max.	Unit
	Operating voltage	1.71	3.6	V
S11	I2S_TX_BCLK/I2S_RX_BCLK cycle time (input)	250	—	ns
S12	I2S_TX_BCLK/I2S_RX_BCLK pulse width high/low (input)	45%	55%	MCLK period
S13	I2S_TX_FS/I2S_RX_FS input setup before I2S_TX_BCLK/I2S_RX_BCLK	30	—	ns
S14	I2S_TX_FS/I2S_RX_FS input hold after I2S_TX_BCLK/I2S_RX_BCLK	—	—	ns
S15	I2S_TX_BCLK to I2S_TXD/I2S_TX_FS output valid	—	—	ns
S16	I2S_TX_BCLK to I2S_TXD/I2S_TX_FS output invalid	0	—	ns
S17	I2S_RXD setup before I2S_RX_BCLK	30	—	ns
S18	I2S_RXD hold after I2S_RX_BCLK	—	—	ns
S19	I2S_TX_FS input assertion to I2S_TXD output valid ¹	—	72	ns

1. Applies to first bit in each frame and only if the TCR4[FSE] bit is clear

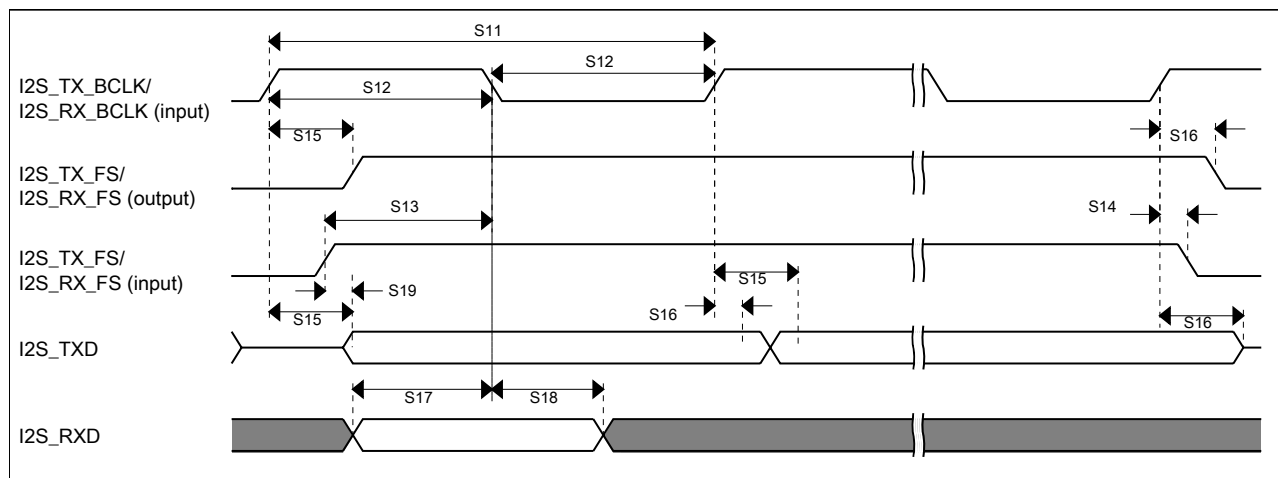

Figure 25. I2S/SAI timing — slave modes

3.9 Human-machine interfaces (HMI)

3.9.1 TSI electrical specifications

Table 50. TSI electrical specifications

Symbol	Description	Min.	Typ.	Max.	Unit
TSI_RUNF	Fixed power consumption in run mode	—	100	—	μA
TSI_RUNV	Variable power consumption in run mode (depends on oscillator's current selection)	1.0	—	128	μA
TSI_EN	Power consumption in enable mode	—	100	—	μA
TSI_DIS	Power consumption in disable mode	—	1.2	—	μA
TSI_TEN	TSI analog enable time	—	66	—	μs
TSI_CREF	TSI reference capacitor	—	1.0	—	pF
TSI_DVOLT	Voltage variation of VP & VM around nominal values	0.19	—	1.03	V

4 Dimensions

4.1 Obtaining package dimensions

Package dimensions are provided in package drawings.

To find a package drawing, go to nxp.com and perform a keyword search for the drawing's document number:

If you want the drawing for this package	Then use this document number
100-pin LQFP	98ASS23308W
121-pin XFBGA	98ASA00595D

5 Pinouts and Packaging

5.1 KL28Z Signal Multiplexing and Pin Assignments

The following table shows the signals available on each pin and the locations of these pins on the devices supported by this document. The Port Control Module is responsible for selecting which ALT function is available on each pin.

NOTE

The 121-pin XFBGA package for this product is not yet available. However, it is included in a Package Your Way program for Kinetis MCUs. Visit nxp.com/KPYW for more details.

NOTE

- A pull-up resistor (typically 4.7 K Ω) must be connected to the EMVSIM0_IO pin if this pin is configured as EMV SIM function.
- PTB0/1, PTC3/4, PTD4/5/6/7 have both high drive and normal/low drive capability. PTD4, PTD5, PTD6, PTD7, PTE20, PTE21, PTE22, PTE23 are also fast pins. When a high bit rate is required on the communication interface pins, it is recommended to use fast pins. In case of high bus loading, the high drive strength of high drive pins must be enabled by setting the corresponding PORTx_PCRn[DSE] bit.
- RESET_b pin is open drain with internal pullup device and passive analog filter when configured as RESET pin (default state after POR). When this pin is configured to other shared functions, the passive analog filter is disabled.

- NMI0_b pin has pullup device enabled and passive analog filter disabled after POR.
- SWD_DIO pin has pullup device enabled after POR.
SWD_CLK has pulldown device enabled after POR.

121 XFB GA	100 LQFP	Pin Name	Default	ALT0	ALT1	ALT2	ALT3	ALT4	ALT5	ALT6	ALT7
E4	1	PTE0	ADC0_SE16	ADC0_SE16	PTE0/ RTC_CLKOUT	LPSP11_SIN	LPUART1_TX		CMP0_OUT	LPI2C1_SDA	
E3	2	PTE1/ LLWU_P0	ADC0_SE17	ADC0_SE17	PTE1/ LLWU_P0	LPSP11_ SOUT	LPUART1_RX			LPI2C1_SCL	
E2	3	PTE2/ LLWU_P1	ADC0_SE18	ADC0_SE18	PTE2/ LLWU_P1	LPSP11_SCK	LPUART1_ CTS_b			LPI2C1_SDAS	
F4	4	PTE3	ADC0_SE19	ADC0_SE19	PTE3	LPSP11_SIN	LPUART1_ RTS_b			LPI2C1_SCLS	
H7	5	PTE4/ LLWU_P2	DISABLED		PTE4/ LLWU_P2	LPSP11_PCS0					
G4	6	PTE5	DISABLED		PTE5	LPSP11_PCS1					
F3	7	PTE6/ LLWU_P16	DISABLED		PTE6/ LLWU_P16	LPSP11_PCS2		I2S0_MCLK	USB_SOF_ OUT		
E6	8	VDD	VDD	VDD							
G7	9	VSS	VSS	VSS							
L6	—	VSS	VSS	VSS							
F1	10	USB0_DP	USB0_DP	USB0_DP							
F2	11	USB0_DM	USB0_DM	USB0_DM							
G1	12	VOUT33	VOUT33	VOUT33							
G2	13	VREGIN	VREGIN	VREGIN							
H1	14	PTE16	ADC0_DP1/ ADC0_SE1	ADC0_DP1/ ADC0_SE1	PTE16	LPSP10_PCS0	LPUART2_TX	TPM0_CLKIN	LPSP11_PCS3	FXIO0_D0	
H2	15	PTE17/ LLWU_P19	ADC0_DM1/ ADC0_SE5a	ADC0_DM1/ ADC0_SE5a	PTE17/ LLWU_P19	LPSP10_SCK	LPUART2_RX	TPM1_CLKIN	LPTMR0_ ALT3/ LPTMR1_ ALT3	FXIO0_D1	
J1	16	PTE18/ LLWU_P20	ADC0_DP2/ ADC0_SE2	ADC0_DP2/ ADC0_SE2	PTE18/ LLWU_P20	LPSP10_ SOUT	LPUART2_ CTS_b	LPI2C0_SDA		FXIO0_D2	
J2	17	PTE19	ADC0_DM2/ ADC0_SE6a	ADC0_DM2/ ADC0_SE6a	PTE19	LPSP10_SIN	LPUART2_ RTS_b	LPI2C0_SCL		FXIO0_D3	
K1	18	PTE20	ADC0_DP0/ ADC0_SE0	ADC0_DP0/ ADC0_SE0	PTE20	LPSP12_SCK	TPM1_CH0	LPUART0_TX		FXIO0_D4	
K2	19	PTE21	ADC0_DM0/ ADC0_SE4a	ADC0_DM0/ ADC0_SE4a	PTE21	LPSP12_ SOUT	TPM1_CH1	LPUART0_RX		FXIO0_D5	
L1	20	PTE22	ADC0_DP3/ ADC0_SE3	ADC0_DP3/ ADC0_SE3	PTE22	LPSP12_SIN	TPM2_CH0	LPUART2_TX		FXIO0_D6	
L2	21	PTE23	ADC0_DM3/ ADC0_SE7a	ADC0_DM3/ ADC0_SE7a	PTE23	LPSP12_PCS0	TPM2_CH1	LPUART2_RX		FXIO0_D7	
F5	22	VDDA	VDDA	VDDA							

Pinouts and Packaging

121 XFB GA	100 LQFP	Pin Name	Default	ALT0	ALT1	ALT2	ALT3	ALT4	ALT5	ALT6	ALT7
G5	23	VREFH/ VREF_OUT	VREFH/ VREF_OUT	VREFH/ VREF_OUT							
G6	24	VREFL	VREFL	VREFL							
F6	25	VSSA	VSSA	VSSA							
L3	26	PTE29	CMP1_IN5/ CMP0_IN5/ ADC0_SE4b	CMP1_IN5/ CMP0_IN5/ ADC0_SE4b	PTE29	EMVSIM0_ CLK	TPM0_CH2	TPM0_CLKIN			
K5	27	PTE30	DAC0_OUT/ CMP1_IN3/ ADC0_SE23/ CMP0_IN4	DAC0_OUT/ CMP1_IN3/ ADC0_SE23/ CMP0_IN4	PTE30	EMVSIM0_ RST	TPM0_CH3	TPM1_CLKIN			
L4	28	PTE31	DISABLED		PTE31	EMVSIM0_ VCCEN	TPM0_CH4	TPM2_CLKIN	LPI2C0_ HREQ		
L5	29	VSS	VSS	VSS							
K6	30	VDD	VDD	VDD							
H5	31	PTE24	ADC0_SE20	ADC0_SE20	PTE24	EMVSIM0_IO	TPM0_CH0		LPI2C0_SCL		
J5	32	PTE25/ LLWU_P21	ADC0_SE21	ADC0_SE21	PTE25/ LLWU_P21	EMVSIM0_PD	TPM0_CH1		LPI2C0_SDA		
H6	33	PTE26	DISABLED		PTE26/ RTC_CLKOUT		TPM0_CH5		LPI2C0_SCLS		USB_CLKIN
J6	34	PTA0	SWD_CLK	TSIO_CH1	PTA0	LPUART0_ CTS_b	TPM0_CH5		LPI2C0_SDAS		SWD_CLK
H8	35	PTA1	DISABLED	TSIO_CH2	PTA1	LPUART0_RX	TPM2_CH0				
J7	36	PTA2	DISABLED	TSIO_CH3	PTA2	LPUART0_TX	TPM2_CH1				
H9	37	PTA3	SWD_DIO	TSIO_CH4	PTA3	LPI2C1_SCL	TPM0_CH0	LPUART0_ RTS_b			SWD_DIO
J8	38	PTA4/ LLWU_P3	DISABLED	TSIO_CH5	PTA4/ LLWU_P3	LPI2C1_SDA	TPM0_CH1				NMI0_b
K7	39	PTA5	DISABLED		PTA5	USB_CLKIN	TPM0_CH2		LPI2C2_ HREQ	I2S0_TX_ BCLK	
E5	—	VDD	VDD	VDD							
G3	—	VSS	VSS	VSS							
K3	40	PTA6	DISABLED		PTA6		TPM0_CH3				
H4	41	PTA7	DISABLED		PTA7	LPSPIO_PCS3	TPM0_CH4		LPI2C2_SDAS		
J9	—	PTA10/ LLWU_P22	DISABLED		PTA10/ LLWU_P22	LPSPIO_PCS2	TPM2_CH0		LPI2C2_SCLS		
J4	—	PTA11/ LLWU_P23	DISABLED		PTA11/ LLWU_P23	LPSPIO_PCS1	TPM2_CH1		LPI2C2_SDA		
K8	42	PTA12	DISABLED		PTA12		TPM1_CH0		LPI2C2_SCL	I2S0_TXD0	
L8	43	PTA13/ LLWU_P4	DISABLED		PTA13/ LLWU_P4		TPM1_CH1		LPI2C2_SDA	I2S0_TX_FS	
K9	44	PTA14	DISABLED		PTA14	LPSPIO_PCS0	LPUART0_TX		LPI2C2_SCL	I2S0_RX_ BCLK	I2S0_TXD0
L9	45	PTA15	DISABLED		PTA15	LPSPIO_SCK	LPUART0_RX			I2S0_RXD0	

121 XFB GA	100 LQFP	Pin Name	Default	ALT0	ALT1	ALT2	ALT3	ALT4	ALT5	ALT6	ALT7
J10	46	PTA16	DISABLED		PTA16	LPSP10_ SOUT	LPUART0_ CTS_b			I2S0_RX_FS	I2S0_RXD0
H10	47	PTA17	ADC0_SE22	ADC0_SE22	PTA17	LPSP10_SIN	LPUART0_ RTS_b			I2S0_MCLK	
L10	48	VDD	VDD	VDD							
K10	49	VSS	VSS	VSS							
L11	50	PTA18	EXTAL0	EXTAL0	PTA18		LPUART1_RX	TPM0_CLKIN			
K11	51	PTA19	XTAL0	XTAL0	PTA19		LPUART1_TX	TPM1_CLKIN		LPTMR0_ ALT1/ LPTMR1_ ALT1	
J11	52	PTA20	RESET_b		PTA20	LPI2C0_SCLS		TPM2_CLKIN			RESET_b
H11	—	PTA29	DISABLED		PTA29	LPI2C0_SDAS					
G11	53	PTB0/ LLWU_P5	ADC0_SE8/ TSIO_CH0	ADC0_SE8/ TSIO_CH0	PTB0/ LLWU_P5	LPI2C0_SCL	TPM1_CH0			FXIO0_D8	
G10	54	PTB1	ADC0_SE9/ TSIO_CH6	ADC0_SE9/ TSIO_CH6	PTB1	LPI2C0_SDA	TPM1_CH1			FXIO0_D9	
G9	55	PTB2	ADC0_SE12/ TSIO_CH7	ADC0_SE12/ TSIO_CH7	PTB2	LPI2C0_SCL	TPM2_CH0		LPUART0_ RTS_b	FXIO0_D10	
G8	56	PTB3	ADC0_SE13/ TSIO_CH8	ADC0_SE13/ TSIO_CH8	PTB3	LPI2C0_SDA	TPM2_CH1	LPSP11_PCS3	LPUART0_ CTS_b	FXIO0_D11	
F11	—	PTB6	DISABLED		PTB6	LPSP11_PCS2					
E11	57	PTB7	DISABLED		PTB7	LPSP11_PCS1					
D11	58	PTB8	DISABLED		PTB8	LPSP11_PCS0				FXIO0_D12	
E10	59	PTB9	DISABLED		PTB9	LPSP11_SCK				FXIO0_D13	
D10	60	PTB10	DISABLED		PTB10	LPSP11_PCS0				FXIO0_D14	
C10	61	PTB11	DISABLED		PTB11	LPSP11_SCK		TPM2_CLKIN		FXIO0_D15	
B10	62	PTB16	TSIO_CH9	TSIO_CH9	PTB16	LPSP11_ SOUT	LPUART0_RX	TPM0_CLKIN	LPSP12_PCS3	FXIO0_D16	
E9	63	PTB17	TSIO_CH10	TSIO_CH10	PTB17	LPSP11_SIN	LPUART0_TX	TPM1_CLKIN	LPSP12_PCS2	FXIO0_D17	
D9	64	PTB18	TSIO_CH11	TSIO_CH11	PTB18		TPM2_CH0	I2S0_TX_ BCLK	LPI2C1_ HREQ	FXIO0_D18	
C9	65	PTB19	TSIO_CH12	TSIO_CH12	PTB19		TPM2_CH1	I2S0_TX_FS	LPSP12_PCS1	FXIO0_D19	
F10	66	PTB20	DISABLED		PTB20	LPSP12_PCS0				CMP0_OUT	
F9	67	PTB21	DISABLED		PTB21	LPSP12_SCK				CMP1_OUT	
F8	68	PTB22	DISABLED		PTB22	LPSP12_ SOUT					
E8	69	PTB23	DISABLED		PTB23	LPSP12_SIN					
B9	70	PTC0	ADC0_SE14/ TSIO_CH13	ADC0_SE14/ TSIO_CH13	PTC0	LPSP12_PCS1		USB_SOF_ OUT	CMP0_OUT	I2S0_TXD0	
D8	71	PTC1/ LLWU_P6	ADC0_SE15/ TSIO_CH14	ADC0_SE15/ TSIO_CH14	PTC1/ LLWU_P6	LPI2C1_SCL	LPUART1_ RTS_b	TPM0_CH0		I2S0_TXD0	

Pinouts and Packaging

121 XFB GA	100 LQFP	Pin Name	Default	ALT0	ALT1	ALT2	ALT3	ALT4	ALT5	ALT6	ALT7
C8	72	PTC2	ADC0_SE11/ CMP1_IN0/ TSIO_CH15	ADC0_SE11/ CMP1_IN0/ TSIO_CH15	PTC2	LPI2C1_SDA	LPUART1_ CTS_b	TPM0_CH1		I2S0_TX_FS	
B8	73	PTC3/ LLWU_P7	CMP1_IN1	CMP1_IN1	PTC3/ LLWU_P7	LPSPiO_PCS1	LPUART1_RX	TPM0_CH2	CLKOUT	I2S0_TX_ BCLK	
F7	74	VSS	VSS	VSS							
E7	75	VDD	VDD	VDD							
B11	—	PTC22	DISABLED		PTC22	LPSPiO_PCS3					
C11	—	PTC23	DISABLED		PTC23	LPSPiO_PCS2					
A8	76	PTC4/ LLWU_P8	DISABLED		PTC4/ LLWU_P8	LPSPiO_PCS0	LPUART1_TX	TPM0_CH3	I2S0_MCLK	CMP1_OUT	
D7	77	PTC5/ LLWU_P9	DISABLED		PTC5/ LLWU_P9	LPSPiO_SCK	LPTMR0_ ALT2/ LPTMR1_ ALT2	I2S0_RXD0		CMP0_OUT	
C7	78	PTC6/ LLWU_P10	CMP0_IN0	CMP0_IN0	PTC6/ LLWU_P10	LPSPiO_ SOUT		I2S0_RX_ BCLK		I2S0_MCLK	
B7	79	PTC7	CMP0_IN1	CMP0_IN1	PTC7	LPSPiO_SIN	USB_SOF_ OUT	I2S0_RX_FS		FXIO0_D20	
A7	80	PTC8	CMP0_IN2	CMP0_IN2	PTC8	LPI2C0_SCL	TPM0_CH4	I2S0_MCLK		FXIO0_D21	
D6	81	PTC9	CMP0_IN3	CMP0_IN3	PTC9	LPI2C0_SDA	TPM0_CH5	I2S0_RX_ BCLK		FXIO0_D22	
C6	82	PTC10	DISABLED		PTC10	LPI2C1_SCL		I2S0_RX_FS		FXIO0_D23	
C5	83	PTC11/ LLWU_P11	DISABLED		PTC11/ LLWU_P11	LPI2C1_SDA		I2S0_RXD0			
B6	84	PTC12	DISABLED		PTC12	LPI2C1_SCLS		TPM0_CLKIN			
A6	85	PTC13	DISABLED		PTC13	LPI2C1_SDAS		TPM1_CLKIN			
A5	86	PTC14	DISABLED		PTC14	EMVSIM0_ CLK					
B5	87	PTC15	DISABLED		PTC15	EMVSIM0_ RST					
A11	88	VSS	VSS	VSS							
—	89	VDD	VDD	VDD							
D5	90	PTC16	DISABLED		PTC16	EMVSIM0_ VCCEN					
C4	91	PTC17	DISABLED		PTC17	EMVSIM0_IO	LPSPiO_PCS3				
B4	92	PTC18	DISABLED		PTC18	EMVSIM0_PD	LPSPiO_PCS2				
A4	—	PTC19	DISABLED		PTC19	LPSPiO_PCS1					
D4	93	PTD0/ LLWU_P12	DISABLED		PTD0/ LLWU_P12	LPSPiO_PCS0	LPUART2_ RTS_b	TPM0_CH0		FXIO0_D0	
D3	94	PTD1	ADC0_SE5b	ADC0_SE5b	PTD1	LPSPiO_SCK	LPUART2_ CTS_b	TPM0_CH1		FXIO0_D1	
C3	95	PTD2/ LLWU_P13	DISABLED		PTD2/ LLWU_P13	LPSPiO_ SOUT	LPUART2_RX	TPM0_CH2		FXIO0_D2	

121 XFB GA	100 LQFP	Pin Name	Default	ALT0	ALT1	ALT2	ALT3	ALT4	ALT5	ALT6	ALT7
B3	96	PTD3	DISABLED		PTD3	LPSP10_SIN	LPUART2_TX	TPM0_CH3		FXIO0_D3	
A3	97	PTD4/ LLWU_P14	DISABLED		PTD4/ LLWU_P14	LPSP11_PCS0	LPUART2_RX	TPM0_CH4	LPUART0_ RTS_b	FXIO0_D4	
A2	98	PTD5	ADC0_SE6b	ADC0_SE6b	PTD5	LPSP11_SCK	LPUART2_TX	TPM0_CH5	LPUART0_ CTS_b	FXIO0_D5	
B2	99	PTD6/ LLWU_P15	ADC0_SE7b	ADC0_SE7b	PTD6/ LLWU_P15	LPSP11_ SOUT	LPUART0_RX			FXIO0_D6	
A1	100	PTD7	DISABLED		PTD7	LPSP11_SIN	LPUART0_TX			FXIO0_D7	
A10	—	PTD8/ LLWU_P24	DISABLED		PTD8/ LLWU_P24	LPI2C0_SCL	LPSP11_PCS1			FXIO0_D24	
A9	—	PTD9	DISABLED		PTD9	LPI2C0_SDA	LPSP12_PCS3			FXIO0_D25	
B1	—	PTD10	DISABLED		PTD10	LPSP12_PCS2	LPI2C0_SCLS			FXIO0_D26	
C2	—	PTD11/ LLWU_P25	DISABLED		PTD11/ LLWU_P25	LPSP12_PCS0	LPI2C0_SDAS			FXIO0_D27	
C1	—	PTD12	DISABLED		PTD12	LPSP12_SCK				FXIO0_D28	
D2	—	PTD13	DISABLED		PTD13	LPSP12_ SOUT				FXIO0_D29	
D1	—	PTD14	DISABLED		PTD14	LPSP12_SIN				FXIO0_D30	
E1	—	PTD15	DISABLED		PTD15	LPSP12_PCS1				FXIO0_D31	
J3	—	NC	NC	NC							
H3	—	NC	NC	NC							
K4	—	NC	NC	NC							
L7	—	NC	NC	NC							

5.2 KL28Z Pinouts

The below figure shows the pinout diagram for the devices supported by this document. Many signals may be multiplexed onto a single pin. To determine what signals can be used on which pin, see the previous section.

Pinouts and Packaging

	1	2	3	4	5	6	7	8	9	10	11	
A	PTD7	PTD5	PTD4/ LLWU_P14	PTC19	PTC14	PTC13	PTC8	PTC4/ LLWU_P8	PTD9	PTD8/ LLWU_P24	VSS	A
B	PTD10	PTD6/ LLWU_P15	PTD3	PTC18	PTC15	PTC12	PTC7	PTC3/ LLWU_P7	PTC0	PTB16	PTC22	B
C	PTD12	PTD11/ LLWU_P25	PTD2/ LLWU_P13	PTC17	PTC11/ LLWU_P11	PTC10	PTC6/ LLWU_P10	PTC2	PTB19	PTB11	PTC23	C
D	PTD14	PTD13	PTD1	PTD0/ LLWU_P12	PTC16	PTC9	PTC5/ LLWU_P9	PTC1/ LLWU_P6	PTB18	PTB10	PTB8	D
E	PTD15	PTE2/ LLWU_P1	PTE1/ LLWU_P0	PTE0	VDD	VDD	VDD	PTB23	PTB17	PTB9	PTB7	E
F	USB0_DP	USB0_DM	PTE6/ LLWU_P16	PTE3	VDDA	VSSA	VSS	PTB22	PTB21	PTB20	PTB6	F
G	VOUT33	VREGIN	VSS	PTE5	VREFH/ VREF_OUT	VREFL	VSS	PTB3	PTB2	PTB1	PTB0/ LLWU_P5	G
H	PTE16	PTE17/ LLWU_P19	NC	PTA7	PTE24	PTE26	PTE4/ LLWU_P2	PTA1	PTA3	PTA17	PTA29	H
J	PTE18/ LLWU_P20	PTE19	NC	PTA11/ LLWU_P23	PTE25/ LLWU_P21	PTA0	PTA2	PTA4/ LLWU_P3	PTA10/ LLWU_P22	PTA16	PTA20	J
K	PTE20	PTE21	PTA6	NC	PTE30	VDD	PTA5	PTA12	PTA14	VSS	PTA19	K
L	PTE22	PTE23	PTE29	PTE31	VSS	VSS	NC	PTA13/ LLWU_P4	PTA15	VDD	PTA18	L
	1	2	3	4	5	6	7	8	9	10	11	

Figure 26. 121 XFBGA Pinout Diagram

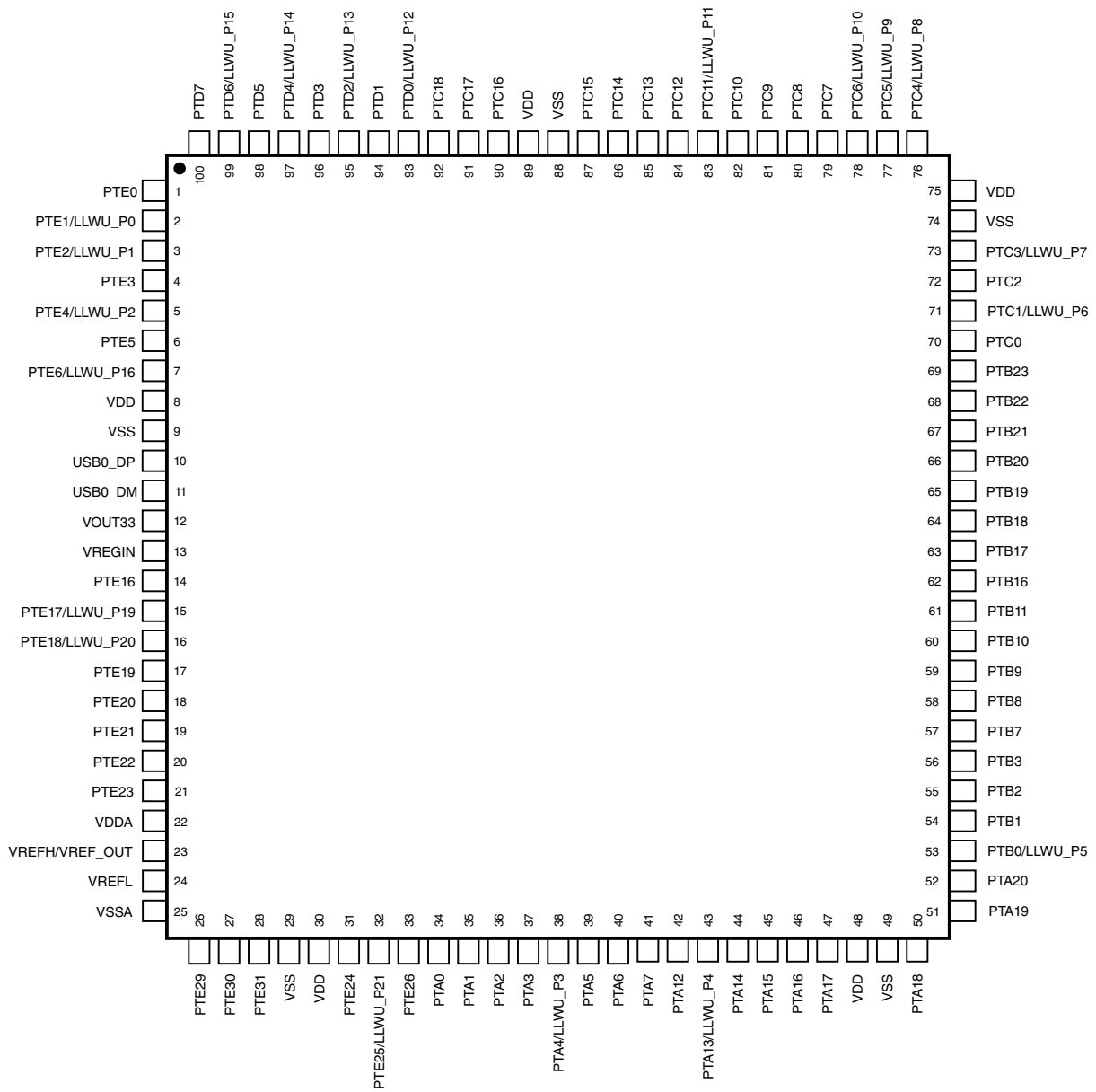

Figure 27. 100 LQFP Pinout Diagram

6 Ordering parts

6.1 Determining valid orderable parts

Valid orderable part numbers are provided on the web. To determine the orderable part numbers for this device, go to nxp.com and perform a part number search for the following device numbers: PKL28Z and MKL28Z

7 Design considerations

7.1 Hardware design considerations

This device contains protective circuitry to guard against damage due to high static voltage or electric fields. However, take normal precautions to avoid application of any voltages higher than maximum-rated voltages to this high-impedance circuit.

7.1.1 Printed circuit board recommendations

- Place connectors or cables on one edge of the board and do not place digital circuits between connectors.
- Drivers and filters for I/O functions must be placed as close to the connectors as possible. Connect TVS devices at the connector to a good ground. Connect filter capacitors at the connector to a good ground.
- Physically isolate analog circuits from digital circuits if possible.
- Place input filter capacitors as close to the MCU as possible.
- For best EMC performance, route signals as transmission lines; use a ground plane directly under LQFP/MAPBGA packages.

7.1.2 Power delivery system

Consider the following items in the power delivery system:

- Use a plane for ground.
- Use a plane for MCU VDD supply if possible.
- Always route ground first, as a plane or continuous surface, and never as sequential segments.
- Route power next, as a plane or traces that are parallel to ground traces.
- Place bulk capacitance, 10 μ F or more, at the entrance of the power plane.
- Place bypass capacitors for MCU power domain as close as possible to each VDD/VSS pair, including VDDA/VSSA and VREFH/VREFL.

- The minimum bypass requirement is to place 0.1 μF capacitors positioned as near as possible to the package supply pins.
- The VREG_IN voltage range is 2.7 V to 5.5 V. Typically, 5.0V is applied here. If USB module is used, this pin must be powered to make the USB transceiver also powered. It is recommended to include a filter circuit with one bulk capacitor (no less than 2.2 μF) and one 0.1 μF capacitor to VREG_IN at this pin to improve USB performance. Total capacitors on VBUS should be less than 10 μF .
- Take special care to minimize noise levels on the VREFH/VREFL inputs. An option is to use the internal reference voltage (output 1.2 V or 2.1 V typically) as the ADC reference.

NOTE

The internal reference voltage output (VREF_OUT) is bonded to the VREFH pin. When the VREF_OUT output is used, a 0.1 μF capacitor is required as a filter. Do not connect any other supply voltage to the pin that has VREF_OUT activated.

7.1.3 Analog design

Each ADC input must have an RC filter as shown in the following figure. The maximum value of R must be smaller than RAS max if high resolution is required. The value of C must be chosen to ensure that the RC time constant is very small compared to the sample period. See [AN4373: Cookbook for SAR ADC Measurements](#) for how to select proper RC values.

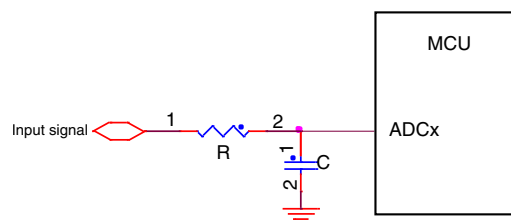

Figure 28. RC circuit for ADC input

High voltage measurement circuits require voltage division, current limiting, and overvoltage protection as shown the following figure. The voltage divider formed by R1 – R4 must yield a voltage less than or equal to VREFH. Typically, VREFH is connected to VDDA. The current must be limited to less than the negative injection current limit. Since the ADC pins do not have diodes to VDD, external clamp diodes must be included to protect against transient over-voltages.

Design considerations

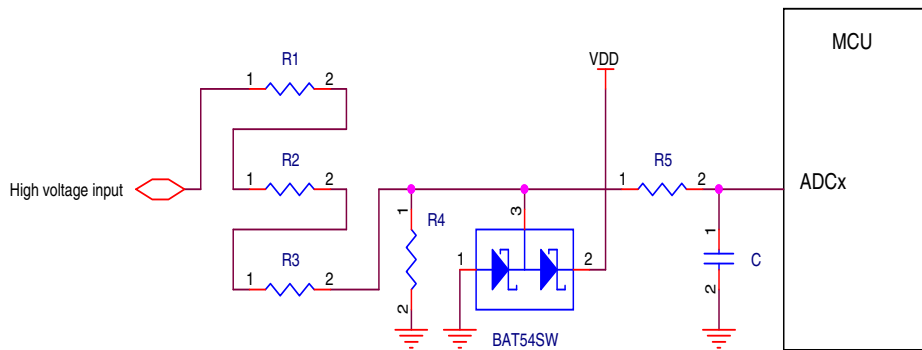

Figure 29. High voltage measurement with an ADC input

7.1.4 Digital design

Ensure that all I/O pins cannot get pulled above VDD (Max I/O is $VDD+0.3V$).

CAUTION

Do not provide power to I/O pins prior to VDD, especially the RESET_b pin.

- High drive pins

PTB0, PTB1, PTC3, PTC4, PTD4, PTD5, PTD6 and PTD7 I/O have both high drive and normal drive capability selected by the associated PTx_PCRn[DSE] control bit. All other GPIOs are normal drive only. When in high drive mode, the sink/source current for a high drive pin can reach 20 mA. However, the total current flowing into the MCU VDD must not exceed maximum limit of IDD.

- Fast pins

PTE20, PTE21, PTE22, PTE23, PTD4, PTD5, PTD6, PTD7 can support fast slew rate of 0.5 ns and are used for high speed communications. It is set/cleared by PTx_PCRn[SRE].

- Default I/O state

Most of digital pins are disabled (in high impedance state) after power up, so a pull-up/down is needed to a determined level for some applications. Please refer to the Signal Multiplexing and Pin Assignments chapter to know the default IO state for a dedicate pin.

- RESET_b pin

The RESET_b pin is an open-drain I/O pin that has an internal pullup resistor. An external RC circuit is recommended to filter noise as shown in the following figure. The resistor value must be in the range of 4.7 k Ω to 10 k Ω ; the recommended capacitance value is 0.1 μ F. The RESET_b pin also has a selectable digital filter to reject spurious noise.

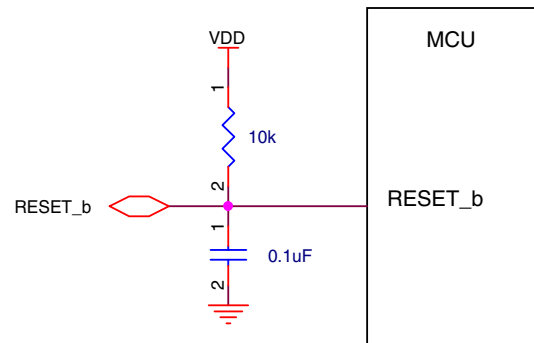

Figure 30. Reset circuit

When an external supervisor chip is connected to the RESET_b pin, a series resistor must be used to avoid damaging the supervisor chip or the RESET_b pin, as shown in the following figure. The series resistor value (RS below) must be in the range of 100 Ω to 1 k Ω depending on the external reset chip drive strength. The supervisor chip must have an active high, open-drain output.

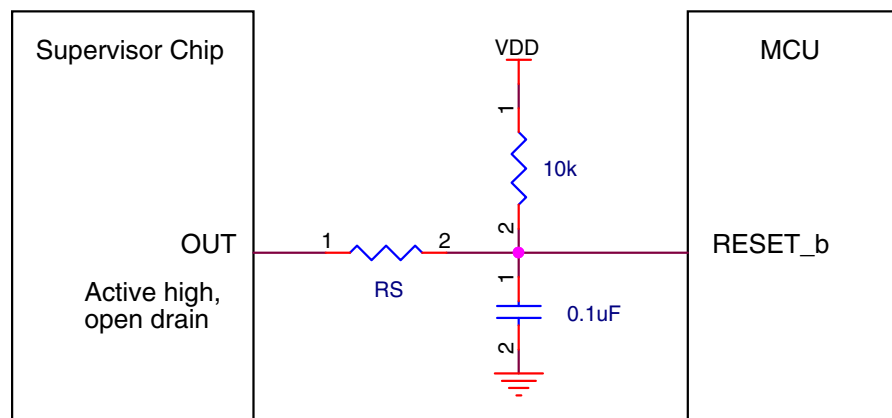

Figure 31. Reset signal connection to external reset chip

- NMI pin

Design considerations

Do not add a pull-down resistor or capacitor on the NMI_b pin, because a low level on this pin will trigger non-maskable interrupt. When this pin is enabled as the NMI function, an external pull-up resistor (10 k Ω) as shown in the following figure is recommended for robustness.

If the NMI_b pin is used as an I/O pin, use the following two ways to disable NMI function:

- Define NMI interrupt handler in which NMI pin function is remapped to other pin mux function
- Disable NMI function by programming flash configuration byte at 0x40d for FOPT, change FOPT[NMI_DIS] bit to zero. It will not take effect until next reset.

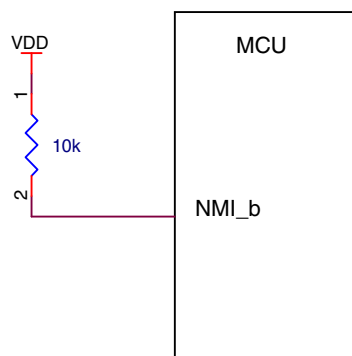

Figure 32. NMI pin biasing

- Debug interface

This MCU uses the standard ARM SWD interface protocol as shown in the following figure. While pull-up or pull-down resistors are not required (SWD_DIO has an internal pull-up and SWD_CLK has an internal pull-down), external 10 k Ω pull resistors are recommended for system robustness. The RESET_b pin recommendations mentioned above must also be considered.

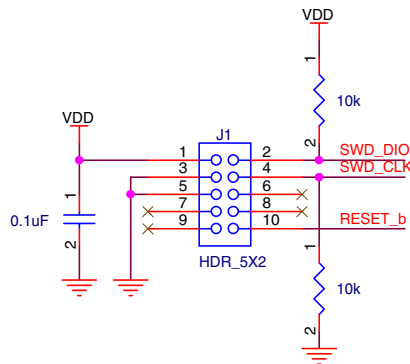

Figure 33. SWD debug interface

- Low leakage stop mode wakeup

Select low leakage wakeup pins (LLWU_Px) to wake the MCU from one of the low leakage stop modes (LLS/VLLSx). See KL28 Signal Multiplexing and Pin Assignments chapter for pin selection.

- Unused pin

Unused GPIO pins must be left floating (no electrical connections) with the MUX field of the pin's PORTx_PCRn register equal to 000. This disables the digital input path to the MCU.

If the USB module is not used, leave the USB data pins (USB0_DP, USB0_DM) floating.

- EMVSIM

When using EMVSIM, a typical 4.7 K Ω pull up resistor should be added on the EMVSIM_IO pin.

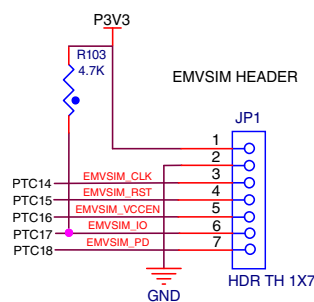

Figure 34. EMVSIM interface

- Pull up resistor for getting correct power consumption result

Design considerations

Connect the pull up resistor to VDD_MCU for the pins like RESET and NMI. For other pull up resistor, do not use VDD_MCU.

7.1.5 Crystal oscillator

When using an external crystal or ceramic resonator as the frequency reference for the MCU clock system, refer to the following table and diagrams.

The feedback resistor, RF, is incorporated internally with the low power oscillators. An external feedback is required when using high gain (HGO=1) mode. In harsh EMC environment, it is recommended to use high gain mode. For low frequency (32 to 40 kHz), switching between high gain and low power is not supported.

The series resistor, RS, is used to limit current to external crystal or resonator to avoid overdrive, and is required in high gain (HGO=1) mode when the crystal or resonator frequency is below 2 MHz. The low power oscillator (HGO=0) must not have any series resistor RS.

Internal load capacitors (Cx, Cy) are provided in the low frequency (32.786kHz) mode. Use the SCxP bits in the SCG_SOSCCFG register to adjust the load capacitance for the crystal. Typically, values of 10 pf to 16 pF are sufficient for 32.768 kHz crystals that have a 12.5 pF CL specification. The internal load capacitor selection must not be used for high frequency crystals and resonators. See crystal or resonator manufacturer's recommendation for parameters about load capacitance and RF.

Table 51. External crystal/resonator connections

Oscillator mode	Diagram
Low frequency (32 kHz-40 kHz), low power	Diagram 1
Low frequency (32 kHz-40 kHz), high gain	Diagram 2, Diagram 4
High/Medium frequency (1-32 MHz), low power	Diagram 3
High/Medium frequency (1-32MHz), high gain	Diagram 4

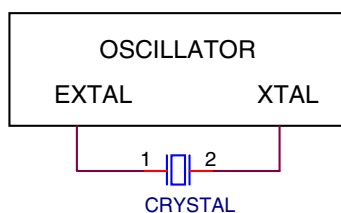

Figure 35. Crystal connection – Diagram 1

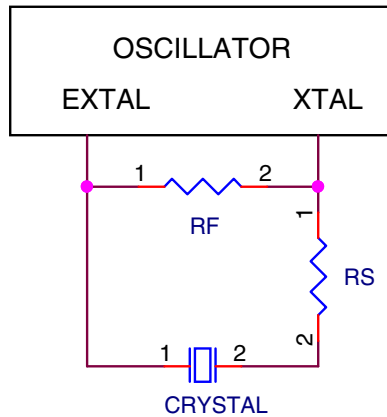

Figure 36. Crystal connection – Diagram 2

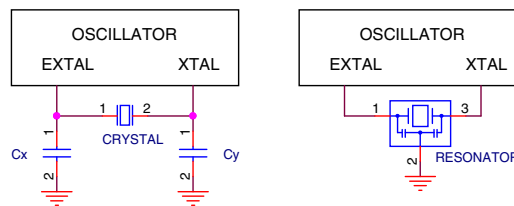

Figure 37. Crystal connection – Diagram 3

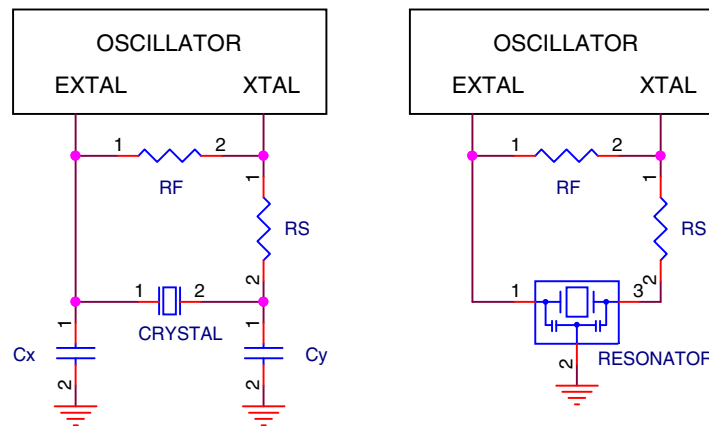

Figure 38. Crystal connection – Diagram 4

7.2 Software considerations

All Kinetis MCUs are supported by comprehensive NXP and third-party hardware and software enablement solutions, which can reduce development costs and time to market. Featured software and tools are listed below. Visit <http://www.nxp.com/kinetis/sw> for more information and supporting collateral.

Evaluation and Prototyping Hardware

Part identification

- NXP Freedom Development Platform: <http://www.nxp.com/freedom>
- Tower System Development Platform: <http://www.nxp.com/tower>

IDEs for Kinetis MCUs

- Kinetis Design Studio IDE: <http://www.nxp.com/kds>
- Partner IDEs: <http://www.nxp.com/kide>

Development Tools

- PEG Graphics Software: <http://www.nxp.com/peg>
- Processor Expert Software and Embedded Components: <http://www.nxp.com/processorexpert>)

Run-time Software

- Kinetis SDK: <http://www.nxp.com/ksdk>
- Kinetis Bootloader: <http://www.nxp.com/kboot>
- ARM mbed Development Platform: <http://www.nxp.com/mbed>
- MQX RTOS: <http://www.nxp.com/mqx>

For all other partner-developed software and tools, visit <http://www.nxp.com/partners>.

8 Part identification

8.1 Description

Part numbers for the chip have fields that identify the specific part. You can use the values of these fields to determine the specific part you have received.

8.2 Format

Part numbers for this device have the following format:

Q KL## A FFF R T PP CC N

8.3 Fields

This table lists the possible values for each field in the part number (not all combinations are valid):

Table 52. Part number fields descriptions

Field	Description	Values
Q	Qualification status	<ul style="list-style-type: none"> M = Fully qualified, general market flow P = Prequalification
KL##	Kinetis family	<ul style="list-style-type: none"> KL28
A	Key attribute	
FFF	Program flash memory size	<ul style="list-style-type: none"> 256 = 256 KB 512 = 512 KB
R	Silicon revision	<ul style="list-style-type: none"> (Blank) = Main A = Revision after main
T	Temperature range (°C)	<ul style="list-style-type: none"> V = -40 to 105
PP	Package identifier	<ul style="list-style-type: none"> LL = 100 LQFP (14 mm x 14 mm) DC = 121XFBGA (8mm x 8mm)
CC	Maximum CPU frequency (MHz)	<ul style="list-style-type: none"> 7 = 72 MHz
N	Packaging type	<ul style="list-style-type: none"> R = Tape and reel (Blank) = Trays

8.4 Example

This is an example part number:

MKL28Z512VDC7

MKL28Z512VLL7

9 Terminology and guidelines

9.1 Definitions

Key terms are defined in the following table:

Term	Definition
Rating	A minimum or maximum value of a technical characteristic that, if exceeded, may cause permanent chip failure:

Table continues on the next page...

Terminology and guidelines

Term	Definition
	<ul style="list-style-type: none"> • <i>Operating ratings</i> apply during operation of the chip. • <i>Handling ratings</i> apply when the chip is not powered. <p>NOTE: The likelihood of permanent chip failure increases rapidly as soon as a characteristic begins to exceed one of its operating ratings.</p>
Operating requirement	A specified value or range of values for a technical characteristic that you must guarantee during operation to avoid incorrect operation and possibly decreasing the useful life of the chip
Operating behavior	A specified value or range of values for a technical characteristic that are guaranteed during operation if you meet the operating requirements and any other specified conditions
Typical value	<p>A specified value for a technical characteristic that:</p> <ul style="list-style-type: none"> • Lies within the range of values specified by the operating behavior • Is representative of that characteristic during operation when you meet the typical-value conditions or other specified conditions <p>NOTE: Typical values are provided as design guidelines and are neither tested nor guaranteed.</p>

9.2 Examples

Operating rating:

Symbol	Description	Min.	Max.	Unit
V _{DD}	1.0 V core supply voltage	-0.3	1.2	V

Operating requirement:

Symbol	Description	Min.	Max.	Unit
V _{DD}	1.0 V core supply voltage	0.9	1.1	V

Operating behavior that includes a typical value:

Symbol	Description	Min.	Typ.	Max.	Unit
I _{WP}	Digital I/O weak pullup/pulldown current	10	70	130	μA

9.3 Typical-value conditions

Typical values assume you meet the following conditions (or other conditions as specified):

Symbol	Description	Value	Unit
T_A	Ambient temperature	25	°C
V_{DD}	Supply voltage	3.3	V

9.4 Relationship between ratings and operating requirements

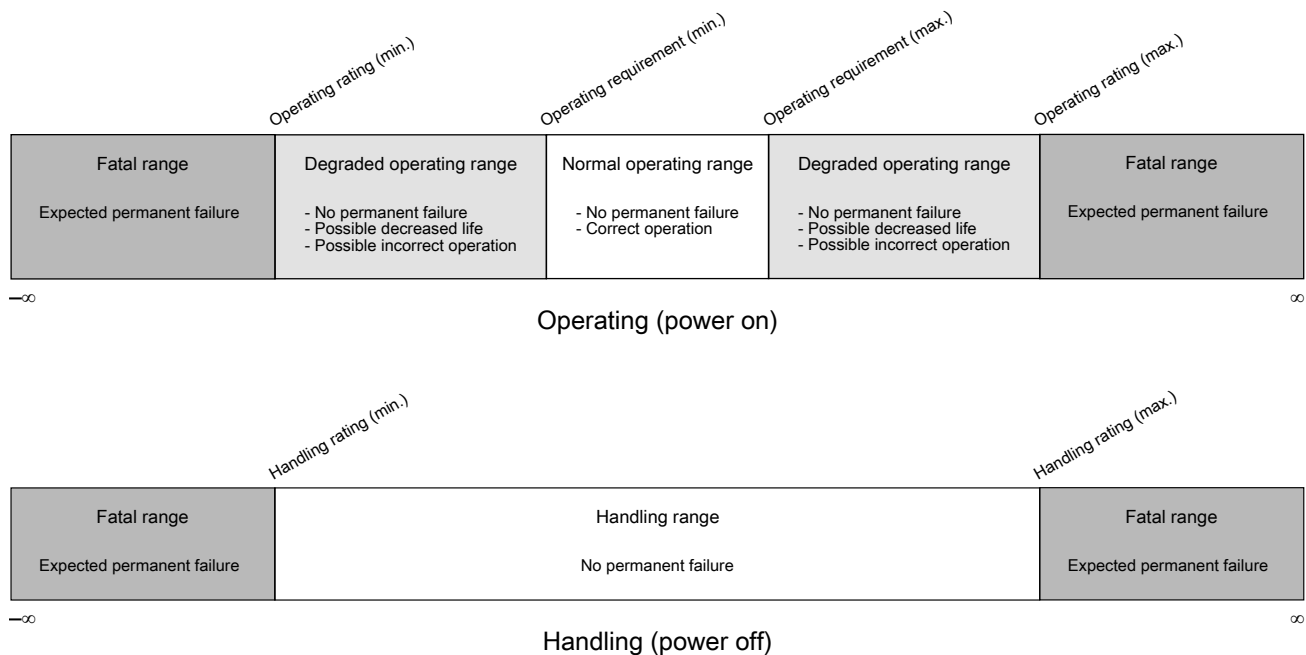

9.5 Guidelines for ratings and operating requirements

Follow these guidelines for ratings and operating requirements:

- Never exceed any of the chip's ratings.
- During normal operation, don't exceed any of the chip's operating requirements.
- If you must exceed an operating requirement at times other than during normal operation (for example, during power sequencing), limit the duration as much as possible.

10 Revision History

The following table provides a revision history for this document.

Table 53. Revision History

Rev. No.	Date	Substantial Changes
0	08/2015	Initial release
1	10/2015	<ul style="list-style-type: none"> • Removed "Ready Play module (RPM)" from the features list • Added "96 MHz high speed mode" to the features list under "Core" • Updated the values in the following sections: <ul style="list-style-type: none"> • Voltage and current operating requirements • Power mode transition operating behaviors • EMC radiated emissions operating behaviors • General switching specifications • Oscillator frequency specifications • 16-bit ADC operating conditions • LPSPI switching specifications • LPI2C specifications • Created new table for topic "Power consumption operating behaviors" • Updated the pinouts • Updated the "Terminology and guidelines" section to a new format
2	04/2016	<ul style="list-style-type: none"> • Removed 64-pin package information and marked 121-pin package information as "Package Your Way" • Updated the values in Power mode transition operating behaviors • Updated values and resolved TBDs in Power consumption operating behaviors • In section Diagram: Typical IDD_RUN operating behavior : <ul style="list-style-type: none"> • Added "For the ALLON curve, all peripheral clocks are enabled as specified in notes of Table 9." • Updated figures • Updated table in Slow IRC (SIRC) specifications • Removed section "Specification Test Methods" • In table VREF full-range operating behaviors, removed the user trim values and updated the factory trim values
2.1	06/2016	<ul style="list-style-type: none"> • In table Table 10 Low power mode peripheral adders — typical value, removed I_{USB_Alive}

How to Reach Us:

Home Page:

nxp.com

Web Support:

nxp.com/support

Information in this document is provided solely to enable system and software implementers to use NXP products. There are no express or implied copyright licenses granted hereunder to design or fabricate any integrated circuits based on the information in this document. NXP reserves the right to make changes without further notice to any products herein.

NXP makes no warranty, representation, or guarantee regarding the suitability of its products for any particular purpose, nor does NXP assume any liability arising out of the application or use of any product or circuit, and specifically disclaims any and all liability, including without limitation consequential or incidental damages. "Typical" parameters that may be provided in NXP data sheets and/or specifications can and do vary in different applications, and actual performance may vary over time. All operating parameters, including "typicals," must be validated for each customer application by customer's technical experts. NXP does not convey any license under its patent rights nor the rights of others. NXP sells products pursuant to standard terms and conditions of sale, which can be found at the following address: nxp.com/SalesTermsandConditions.

NXP, the NXP logo, NXP SECURE CONNECTIONS FOR A SMARTER WORLD, Freescale, the Freescale logo, and Kinetis are trademarks of NXP B.V. All other product or service names are the property of their respective owners. ARM, the ARM powered logo, and Cortex are registered trademarks of ARM Limited (or its subsidiaries) in the EU and/or elsewhere. All rights reserved.

© 2015 - 2016 NXP B.V.

Document Number MKL28Z512Vxx7
Revision 2.1, 06/2016





Компания «ЭлектроПласт» предлагает заключение долгосрочных отношений при поставках импортных электронных компонентов на взаимовыгодных условиях!

Наши преимущества:

- Оперативные поставки широкого спектра электронных компонентов отечественного и импортного производства напрямую от производителей и с крупнейших мировых складов;
- Поставка более 17-ти миллионов наименований электронных компонентов;
- Поставка сложных, дефицитных, либо снятых с производства позиций;
- Оперативные сроки поставки под заказ (от 5 рабочих дней);
- Экспресс доставка в любую точку России;
- Техническая поддержка проекта, помощь в подборе аналогов, поставка прототипов;
- Система менеджмента качества сертифицирована по Международному стандарту ISO 9001;
- Лицензия ФСБ на осуществление работ с использованием сведений, составляющих государственную тайну;
- Поставка специализированных компонентов (Xilinx, Altera, Analog Devices, Intersil, Interpoint, Microsemi, Aeroflex, Peregrine, Syfer, Eurofarad, Texas Instrument, Miteq, Cobham, E2V, MA-COM, Hittite, Mini-Circuits, General Dynamics и др.);

Помимо этого, одним из направлений компании «ЭлектроПласт» является направление «Источники питания». Мы предлагаем Вам помощь Конструкторского отдела:

- Подбор оптимального решения, техническое обоснование при выборе компонента;
- Подбор аналогов;
- Консультации по применению компонента;
- Поставка образцов и прототипов;
- Техническая поддержка проекта;
- Защита от снятия компонента с производства.



Как с нами связаться

Телефон: 8 (812) 309 58 32 (многоканальный)

Факс: 8 (812) 320-02-42

Электронная почта: org@eplast1.ru

Адрес: 198099, г. Санкт-Петербург, ул. Калинина, дом 2, корпус 4, литера А.