

2Vrms Ground Referenced Stereo Line Amplifier

■ GENERAL DESCRIPTION

The **NJU72015** is an audio line Amplifier . It can swing 2Vrms (5.6V peak-to-peak) signal at 3.3V operating voltage.

Ground-referenced outputs eliminate output coupling capacitor. It contains differential input.

The pop noise suppression circuit removes a pop noise at the power-on and power-off.

■ PACKAGE OUTLINE

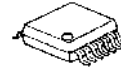

NJU72015V

■ APPLICATIONS

- Audio applications requiring 2Vrms outputs

■ FEATURES

- Operating Voltage +3.0 to +3.6V
- Operating Current $I_{DD}=5\text{mA typ. at } V^+=3.3\text{V, No Signal, No Load}$
- Output Coupling Capacitor-less
- Differential Input
- Pop Noise Suppression Circuit
- C-MOS Technology
- Package Outline SSOP14

■ BLOCK DIAGRAM

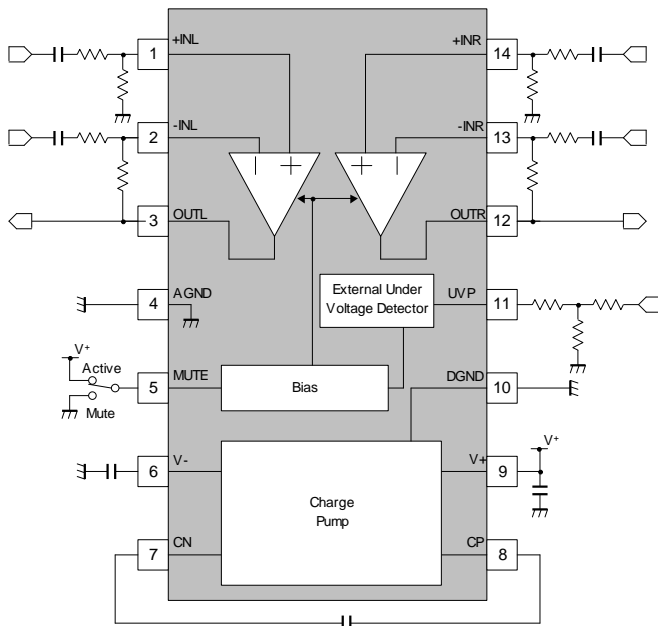

■ PIN CONFIGURATION

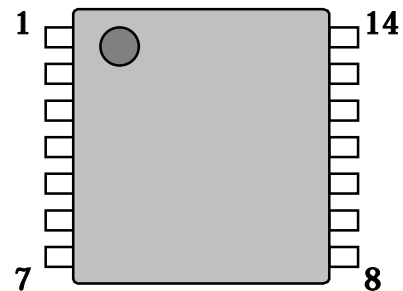

No.	Symbol	Function
1	+INL	Lch Noninverted Input
2	-INL	Lch Inverted Input
3	OUTL	Lch Output
4	GND	Ground
5	MUTE	Mute Control
6	V-	V- Power Supply
7	CN	Flying Capacitor Negative Terminal
8	CP	Flying Capacitor Positive Terminal
9	V+	V+ Power Supply
10	DGND	Ground
11	UVP	Undervoltage Protection Input
12	OUTR	Rch Output
13	-INR	Rch Inverted Input
14	+INR	Rch Noninverted Input

■ ABSOLUTE MAXIMUM RATING (Ta=25°C)

PARAMETER	SYMBOL	RATING	UNIT
Supply Voltage	V ⁺	+4	V
Power Dissipation	P _D	530 ^(Note1)	mW
Maximum Input Voltage	V _{IMAX}	-V ⁺ -0.3 ~ V ⁺ +0.3	V
Operating Temperature Range	Topr	-40 ~ +85	°C
Storage Temperature Range	Tstg	-40 ~ +125	°C

(Note1) EIA/JEDEC STANDARD Test board (76.2x114.3x1.6mm, 2layer, FR-4) mounting

■ RECOMMENDED OPERATING CONDITIONS

(V⁺=3.3V, Ta=25°C unless otherwise specified)

PARAMETER	SYMBOL	TEST CONDITION	MIN.	TYP.	MAX.	UNIT
Operating Voltage	V ⁺		3.0	3.3	3.6	V

■ ELECTRICAL CHARACTERISTICS

◆ DC CHARACTERISTICS

(V⁺=3.3V, Mute=OFF, R_L=10kΩ, Ta=25°C unless otherwise specified)

PARAMETER	SYMBOL	TEST CONDITION	MIN.	TYP.	MAX.	UNIT
Operating Current	I _{DD}	No signal, No load	-	5	10	mA
Power Supply Rejection Ratio	PSRR	V ⁺ =3V to 3.6V	-	80	-	dB
External undervoltage detection	V _{uvp}		-	1.25	-	V
External undervoltage detection hysteresis current	I _{Hys}		-	5	-	μA
Output Offset Voltage	V _{OS}	R _g =0Ω	-	-	1	mV

◆ AC CHARACTERISTICS

(V⁺=3.3V, f=1kHz, Vin=1Vrms [differential input], Mute=OFF, R_{IN}=10kΩ, R_{fb}=20kΩ, R_L=10kΩ, Ta=25°C unless otherwise specified)

PARAMETER	SYMBOL	TEST CONDITION	MIN.	TYP.	MAX.	UNIT
Maximum Output Voltage Level	V _{OMAX}	THD=1%	-	2.3	-	Vrms
Mute Level	V _{MUTE}	R _g =0Ω, Mute=ON	-	-80	-	dB
Equivalent Input Noise Voltage	V _{NI}	R _g =0Ω, A-weighted	-	-106	-	dB
Total Harmonic Distortion	THD	BW:400Hz-22kHz	-	0.003	-	%
Channel Separation	CS	R _g =600Ω, Bandpass	-	110	-	dB

■ CONTROL CHARACTERISTICS

(V⁺=3.3V, Ta=25°C unless otherwise specified)

PARAMETER	SYMBOL	TEST CONDITION	MIN.	TYP.	MAX.	UNIT
Mute terminal High	MuteH	Mute=OFF	0.7V ⁺	-	V ⁺	V
Mute terminal Low	MuteL	Mute=ON	0	-	0.3V ⁺	V

TEST CIRCUIT

◆ I_{DD}

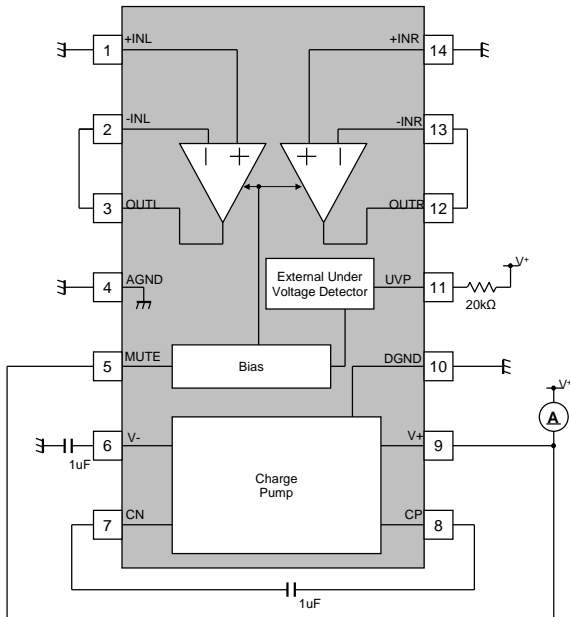

◆ PSRR

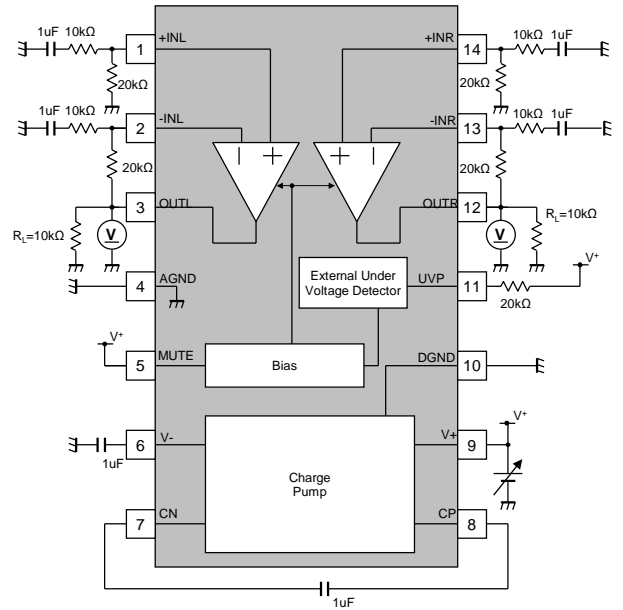

◆ V_{UVP} , I_{Hys} , V_{OMAX} , V_{MUTE}

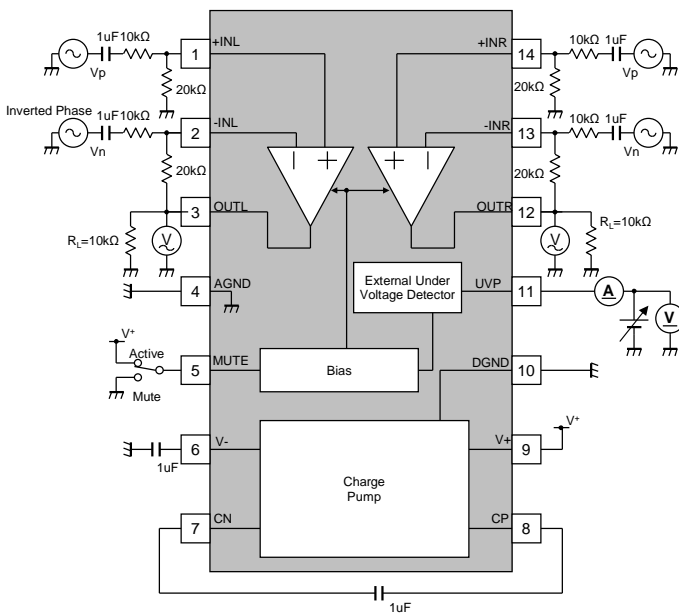

◆ V_{OS}

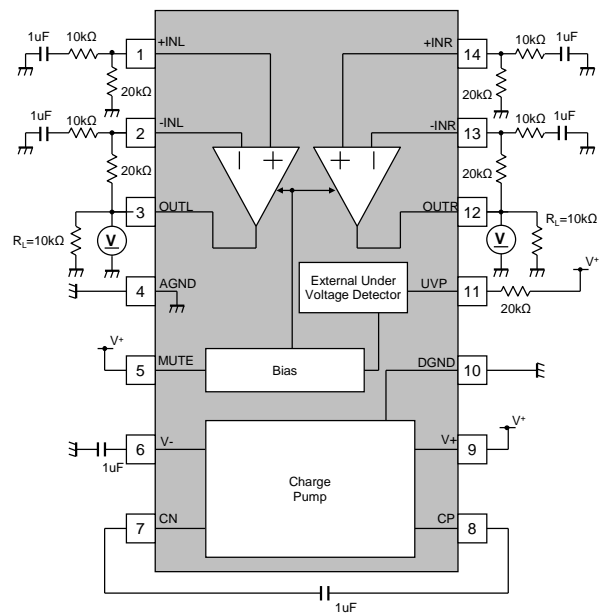

◆ V_{NI}

V_{NI} = Measurement - 12dB

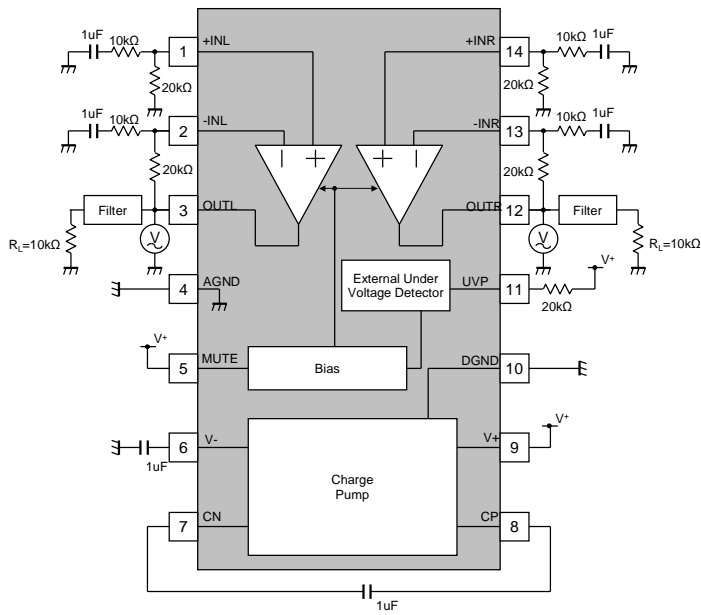

◆ THD

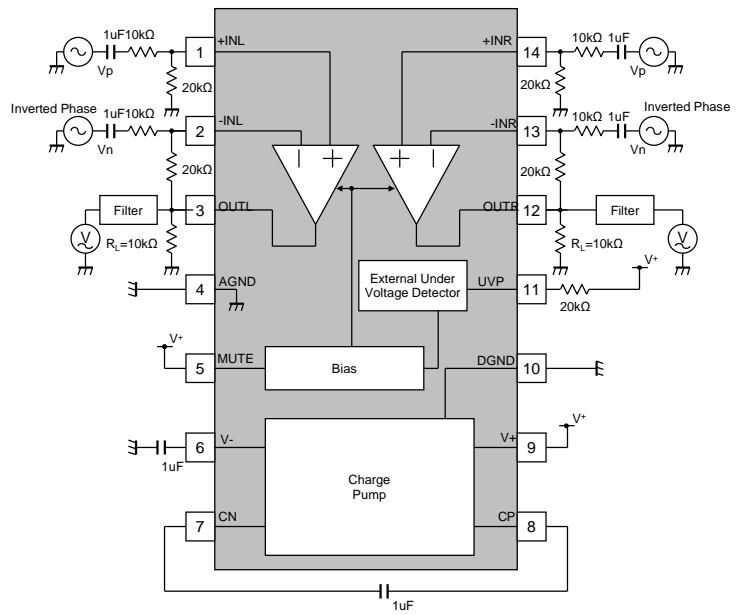

◆ CS

OUTL: $CS = 20 * \text{Log}(\text{OUTR}/\text{OUTL})$
 OUTR: $CS = 20 * \text{Log}(\text{OUTL}/\text{OUTR})$

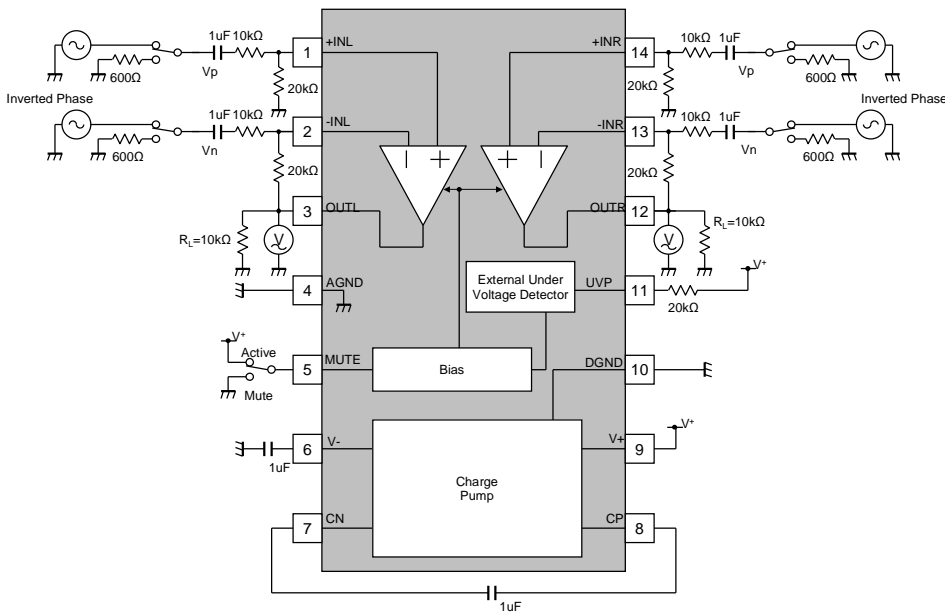

APPLICATION CIRCUIT

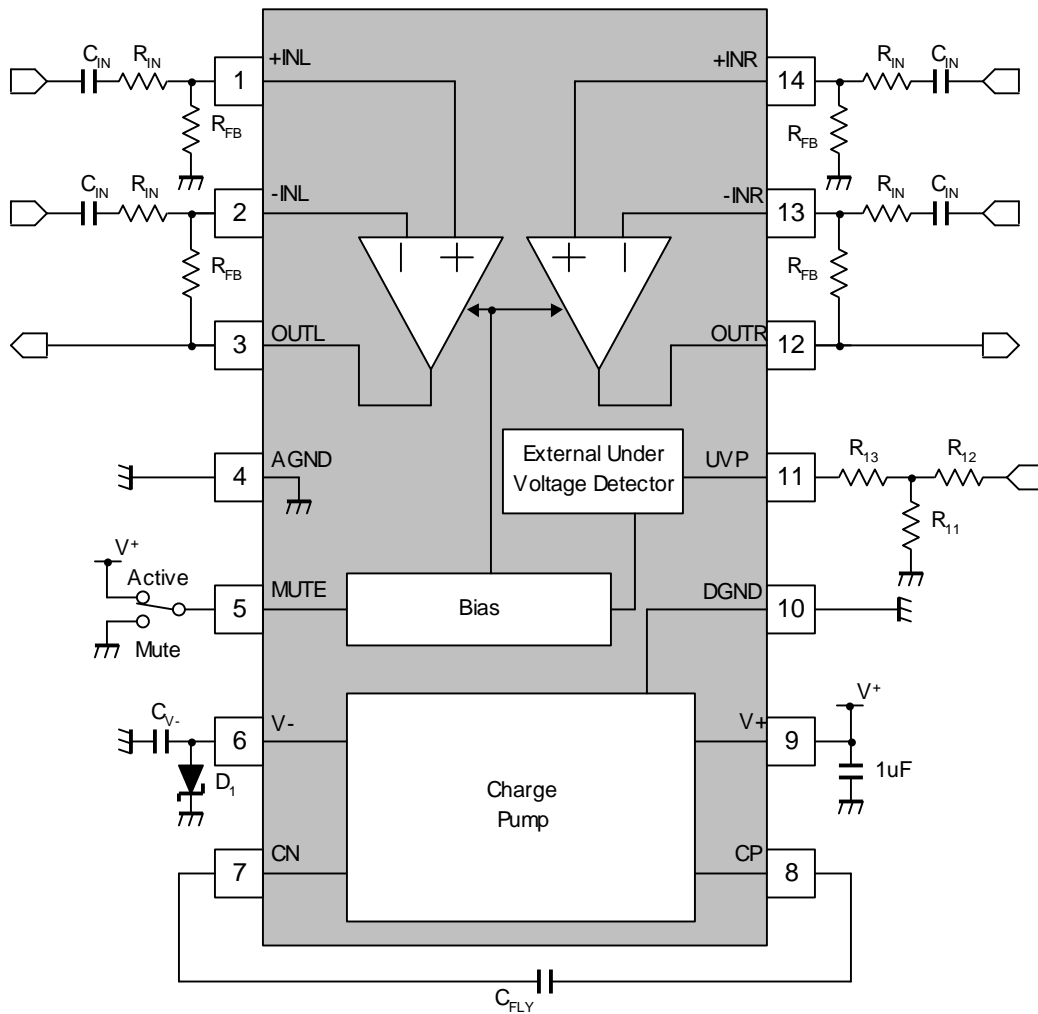

*1) Connect a zener diode between V- terminal[6pin] and GND terminal[8pin] to prevent connecting V- terminal[6pin] and V+ terminal[3pin].

APPLICATION CIRCUIT

Operating Overview

The drawing in Fig 1 illustrates the internal circuit in NJU72015. The NJU72015 has a charge-pump for negative power supply, pop noise suppression circuit, external under voltage detector, and a line amplifier.

The NJU72015 operates from a single supply voltage from 3.0V to 3.6V and the NJU72015's line drivers use a charge pump to invert the positive power supply (V+) to negative power supply (V-), see Fig 2. The output voltages are centered at zero volts with the capability to swing to the positive rail or negative rail. This feature eliminates the output capacitor that is using in conventional line driver operating by a single-supply voltage.

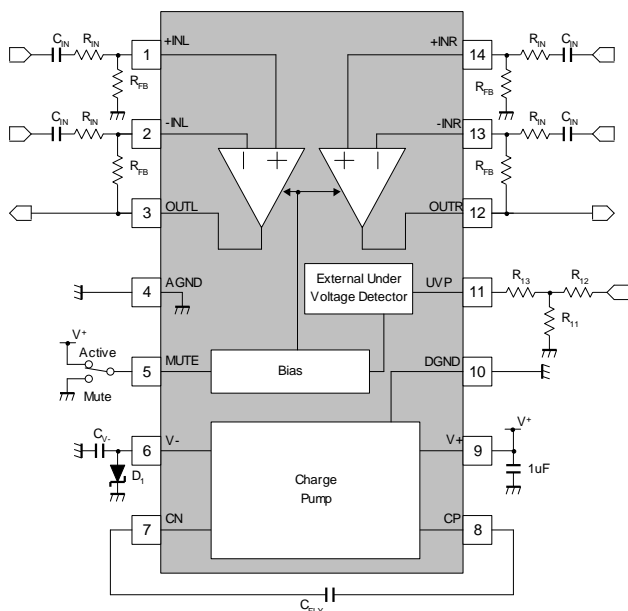

Fig.1 NJU72015 Block diagram

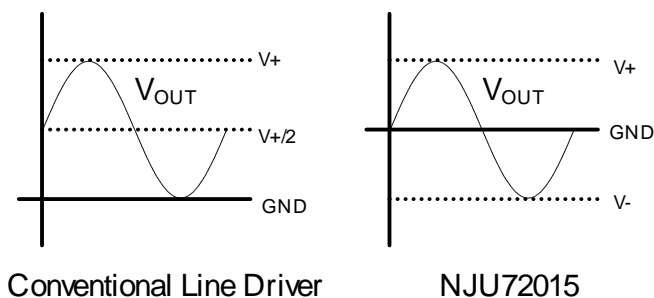

Fig.2 Capacitor-free Operation

Gain Setting Resistor

The drawing in Fig.1 illustrates the gain setting circuit configuration of NJU72015. The differential input gain of the NJU72015 is set by:

$$A_V = \frac{R_{FB}}{R_{IN}}$$

The value of Gain setting resistors, R_{IN} and R_{FB}, affect noise, stability and input capacitor size. Selecting values that are too low demands a large input ac-coupling capacitor, C_{IN}. Selecting values that are too high increases the noise of the amplifier.

Input Coupling Capacitor

An input capacitor, C_{IN}, is required to be added in series with the audio signal into the input pins of the NJU72015. The capacitor allows the amplifier to bias the input signal to the proper DC level for optimum operation. These capacitors form a high-pass filter with the input resistor, R_{IN}. The cutoff frequency is set by:

$$f_{C(HPF)} = \frac{1}{2\pi R_{IN} C_{IN}}$$

The value of C_{IN} must be considered carefully because it directly affects the low frequency response and can distort the audio signal.

Technical Information

◆Flying Capacitor

The flying capacitor is required to generate a negative supply. To achieve a high efficiency, low-ESR capacitors (ceramic capacitor) are to be selected, and to be placed near the CP terminal (pin7) and CN terminal (pin8) so as to reduce the resistance caused by the PCB trace. The recommended value of this capacitor is 1uF. Selecting values that are too low might reduce the maximum output voltage and might not be operated to specifications.

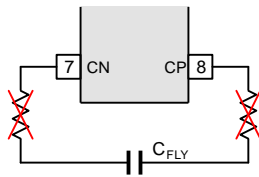

Fig.3 Flying capacitor @ 7pin/8pin

◆Negative supply decoupling Capacitor

To achieve a high efficiency on the negative voltage regulator (negative supply for the amplifier circuit), low ESR capacitor (ceramic capacitor) is to be used for this decoupling capacitor. This capacitor is to be placed near the V⁻ terminal (pin6) so as to reduce the resistance caused by the PCB trace. The recommended value of this capacitor is 1uF.

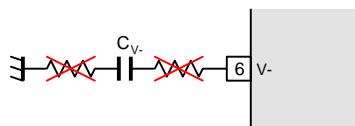

Fig.4 Decoupling capacitor @ 6pin

◆Protection Diode

For protection purpose, it is advisable to place a low V_f diode (Schottky diode) to Ground at V⁻ terminal (pin 6). The external diodes will protect the IC negative supply terminal when a positive voltage is accidentally applied to the pin.

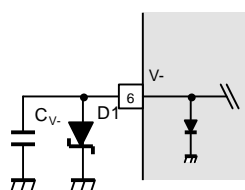

Fig.5 Negative supply terminal @ 6pin

◆External Under Voltage Protection

External under voltage detection can be used to mute the NJU72015's output before an input device can generate a pop noise.

The active-mute threshold at the UVP pin is 1.25V. The user selects a resistor divider to obtain the active-mute threshold and hysteresis for the specific application. The threshold is set by:

$$V_{HYS} = 5\mu \times R_{13} \frac{R_{11} + R_{12}}{R_{12}}$$

$$V_{UVP} = 1.25 \times \frac{R_{11} + R_{12}}{R_{12}} - V_{HYS}$$

$$= (1.25 - 5\mu \times R_{13}) \times \frac{R_{11} + R_{12}}{R_{12}}$$

with the condition $R_{13} \gg R_{11} // R_{12}$

For example, to obtain $V_{UVP}=4V$ and 1V hysteresis, $R_{11}=3k\Omega$, $R_{12}=1k\Omega$ and $R_{13}=50k\Omega$.

If the UVP function is not used, A pull-up resistance ,R_{PULL} is to be connected between UVP terminal and V+ terminal.

●Application Circuit for Using UVP

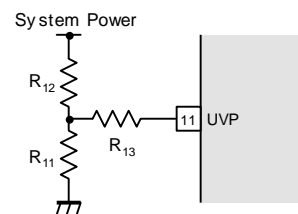

●Application Circuit for Not Using UVP

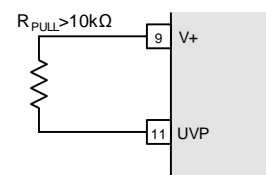

● Sequence of UVP Function

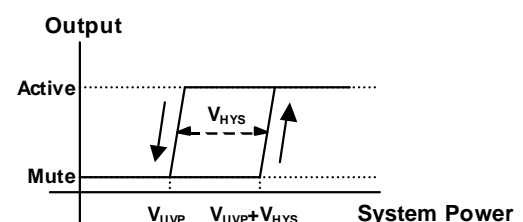

Fig.6 UVP function

◆Power up & down sequence to minimize pop noise

To further reduce pop noise, Recommend to Fig.7 how Power up and down sequence.

➤ *When power supply is turned ON*

To further reduce pop noise during power ON, the MUTE terminal should switch L->H after the power supply terminal has turned ON. It is recommended to have a time interval of 10msec (T_{ON}) or more between these two transitions.

➤ *When power supply is turned OFF*

To further reduce pop noise during power OFF, the MUTE terminal should switch H->L after the power supply terminal has turned OFF. It is recommended to have a time interval of 10msec (T_{OFF}) or more between these two transitions.

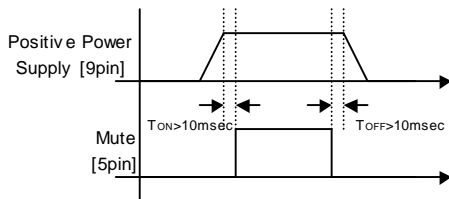

Fig.7 Timing diagram when turning on power supply and intercepting it

■ TERMINAL DESCRIPTION

Terminal	SYMBOL	FUNCTION	EQUIVALENT CIRCUIT	VOLTAGE
1 2 13 14	+INL -INL -INR +INR	AC Input		0V
2 9	OUTL OUTR	AC Output		0V
5	MUTE	MUTE Control		0V
7 8 9	CN CP DGND	Flying Capacitor Negative Terminal Flying Capacitor Positive Terminal Ground		- - 0V

■ TERMINAL DESCRIPTION

Terminal	SYMBOL	FUNCTION	EQUIVALENT CIRCUIT	VOLTAGE
11	UVP	Undervoltage Protection Input		-

TYPICAL CHARACTERISTICS

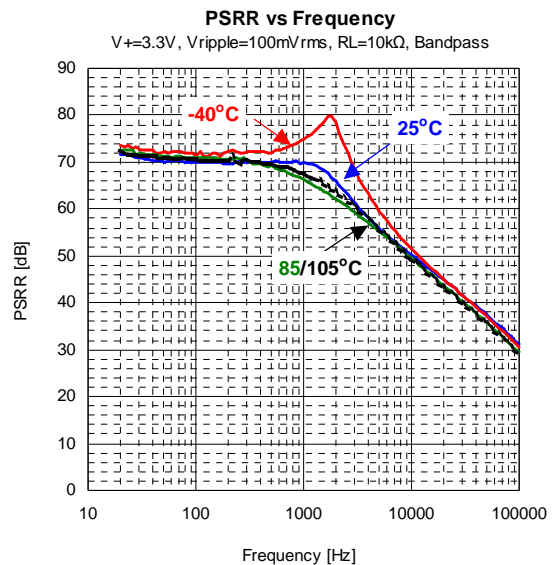
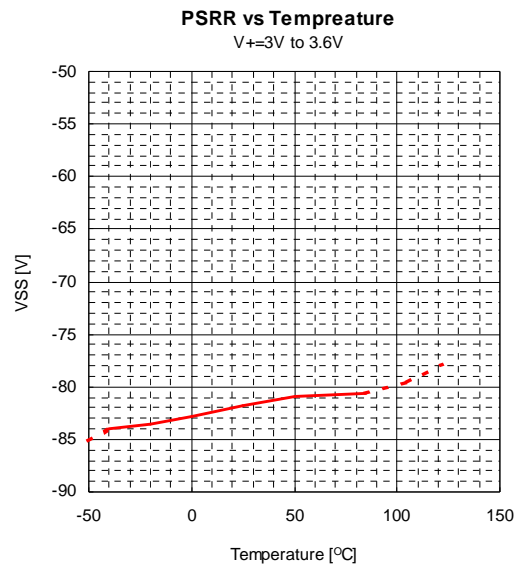
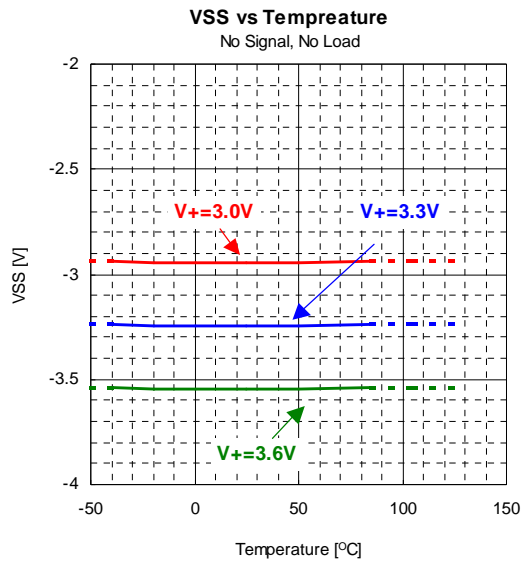
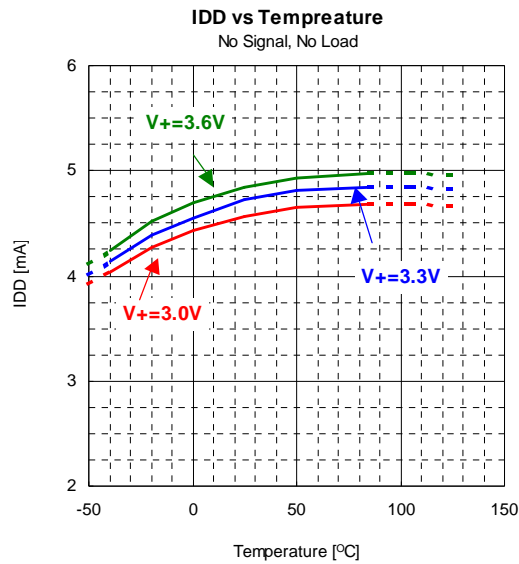
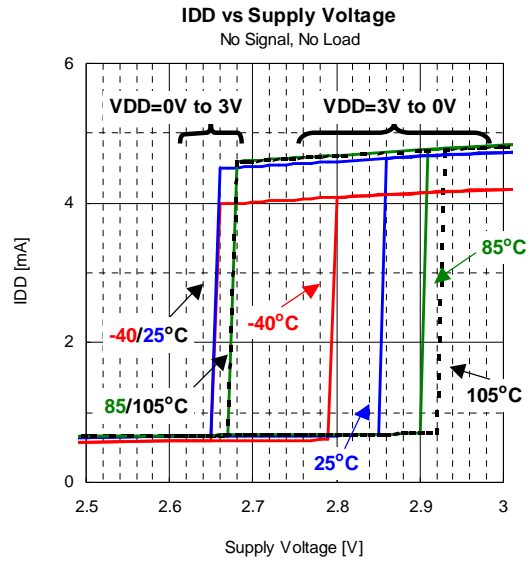
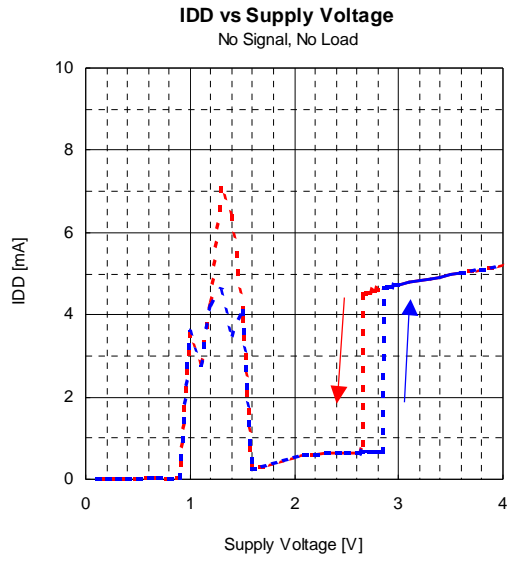

TYPICAL CHARACTERISTICS

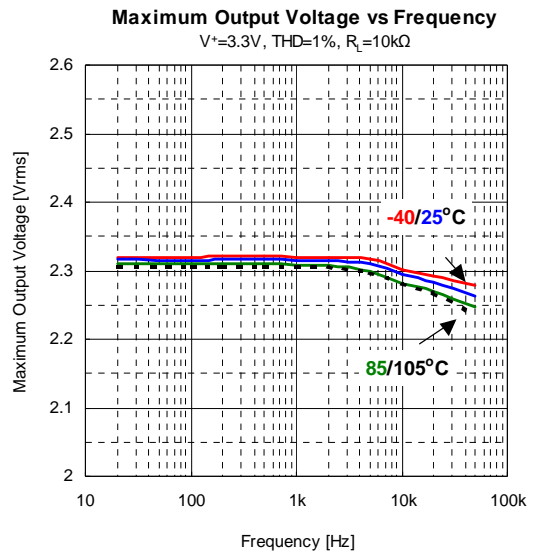
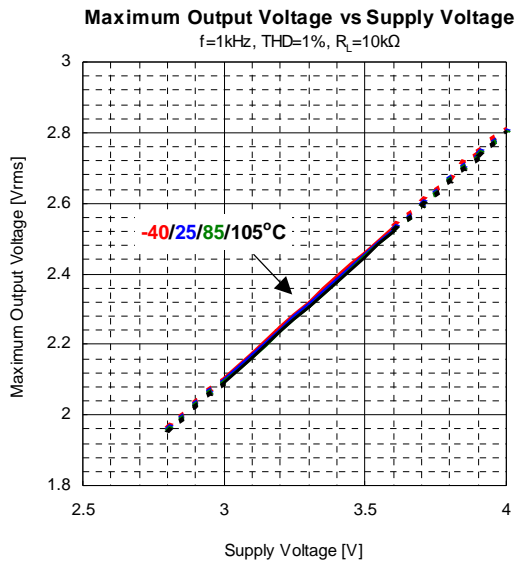
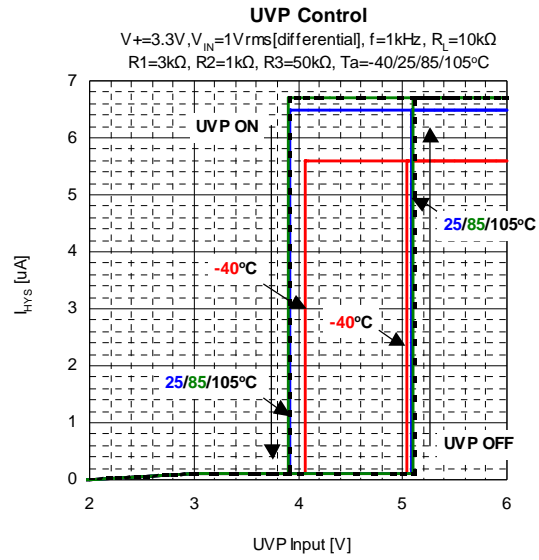
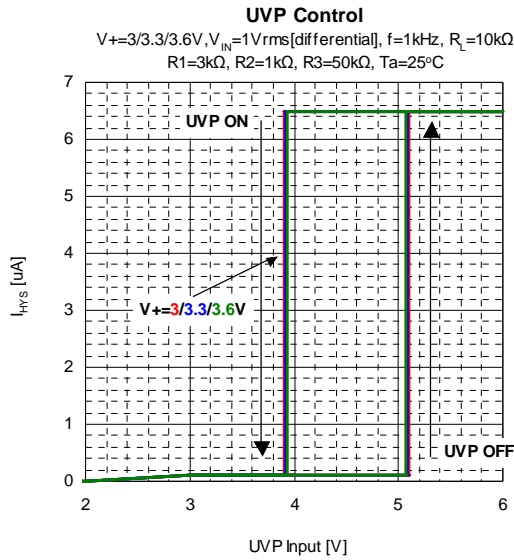
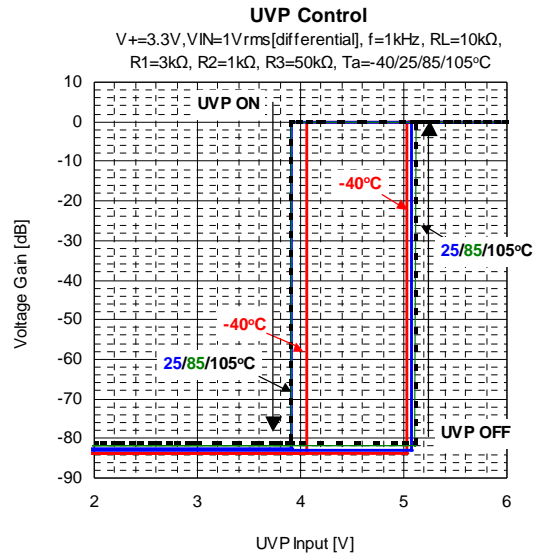
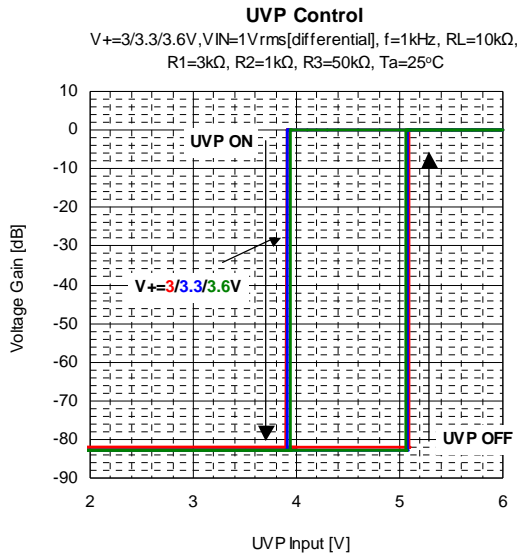

TYPICAL CHARACTERISTICS

Maximum Output Voltage vs Temperature
 $V_+ = 3.3V, f = 1kHz, THD = 1\%, R_L = 10k\Omega$

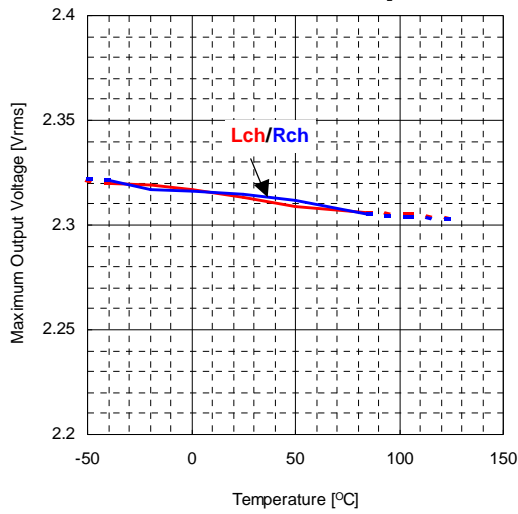

V_{MUTE} vs Temperature

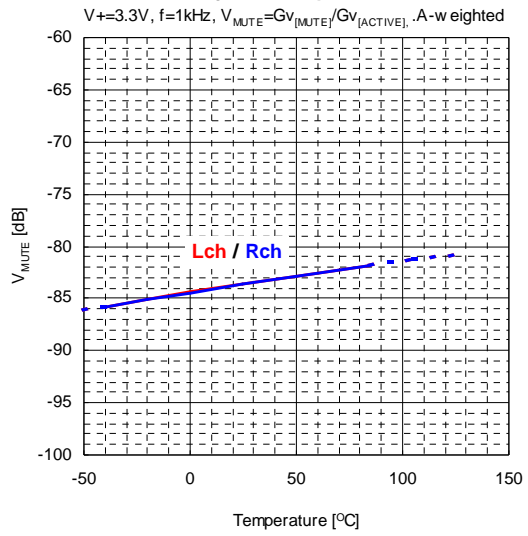

Mute Control

$V_+ = 3/3.3/3.6V, V_{IN} = 1V_{rms}$ [differential], $f = 1kHz, R_L = 10k\Omega$
 $T_a = 25^\circ C$

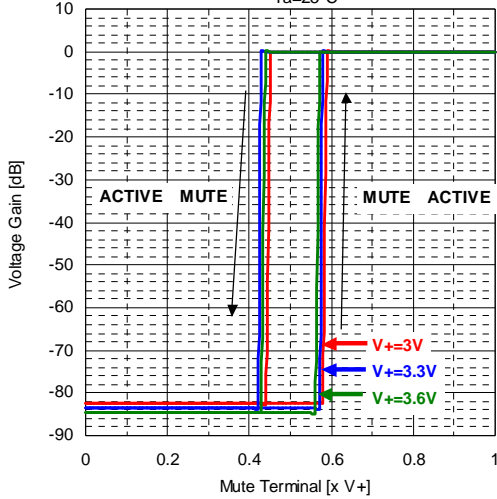

Mute Control

$V_+ = 3.3V, V_{IN} = 1V_{rms}$ [differential], $f = 1kHz, R_L = 10k\Omega$
 $T_a = -40/25/85/105^\circ C$

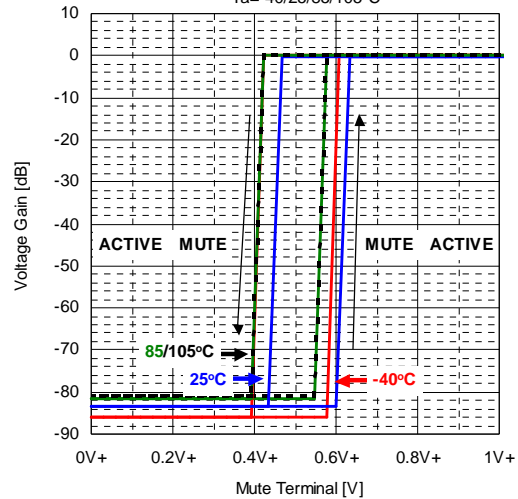

V_{NI} vs Temperature

$V_+ = 3.3V, R_g = 0\Omega$, A-w eighted

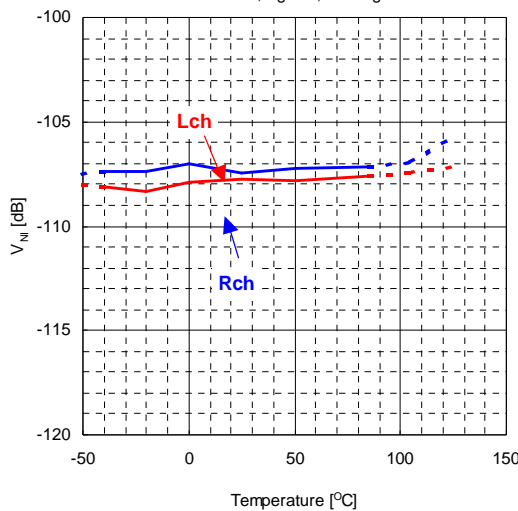

THD+N vs Temperature

$V_+ = 3.3V, V_{IN} = 1V_{rms}$ [differential], $f = 1kHz, R_L = 10k\Omega$,
 BW: 400-22kHz

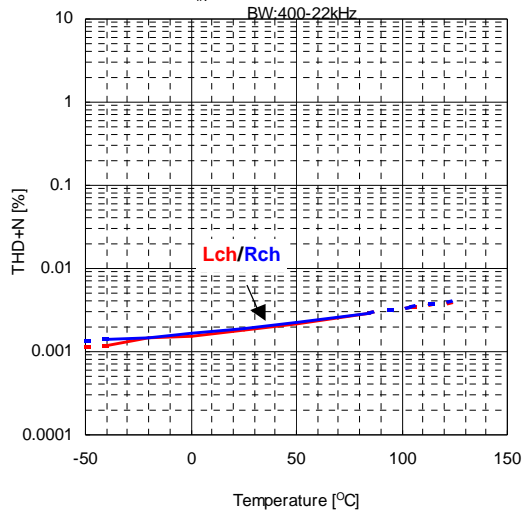

TYPICAL CHARACTERISTICS

THD+N vs Output Voltage

$V^+=3.3V$, BW:10-22kHz($f=100/1kHz$), 10-80kHz($f=10kHz$)

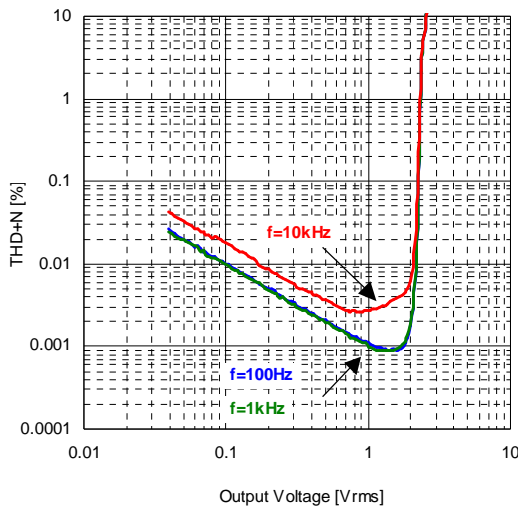

THD+N vs Output Voltage

$V^+=3.3V$, $f=100Hz$, BW:10-22kHz, $R_L=10k\Omega$

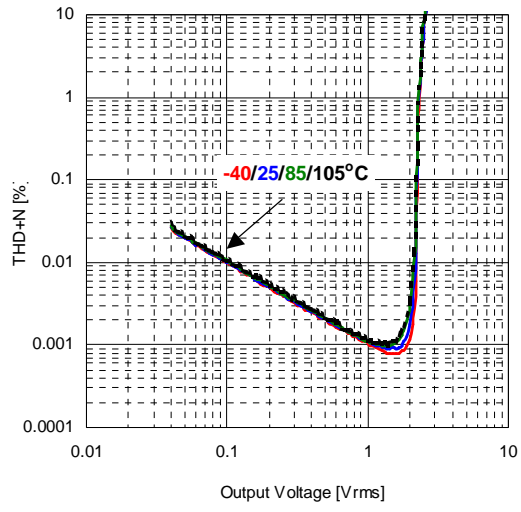

THD+N vs Output Voltage

$V^+=3.3V$, $f=1kHz$, BW:10-22kHz, $R_L=10k\Omega$

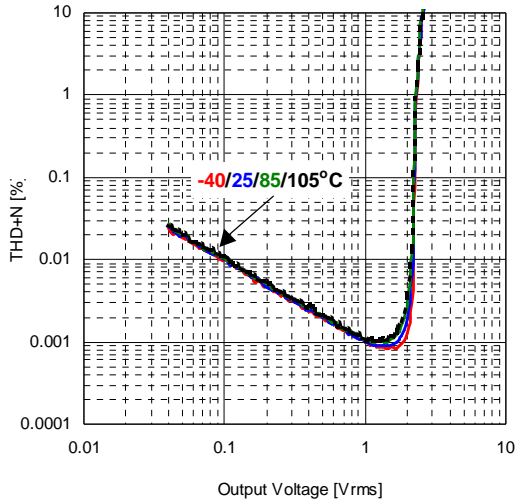

THD+N vs Output Voltage

$V^+=3.3V$, $f=10kHz$, BW:10-80kHz, $R_L=10k\Omega$

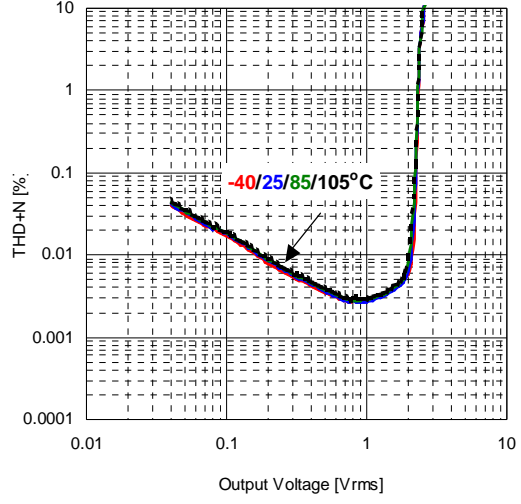

THD+N vs Frequency

$V^+=3.3V$, $V_o=1.8Vrms$, BW:10-80kHz

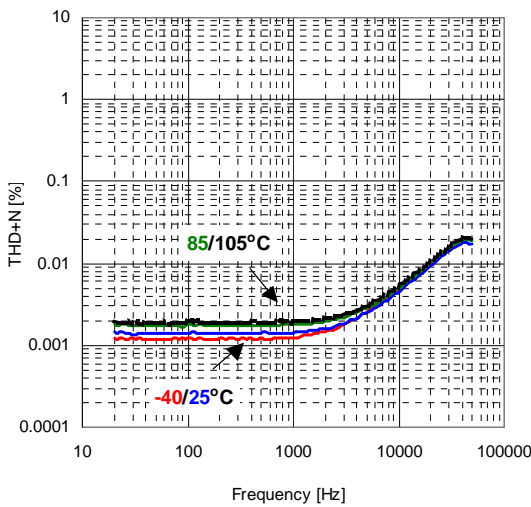

THD+N vs Frequency

$V^+=3.3V$, $V_o=2.0Vrms$, BW:10-80kHz

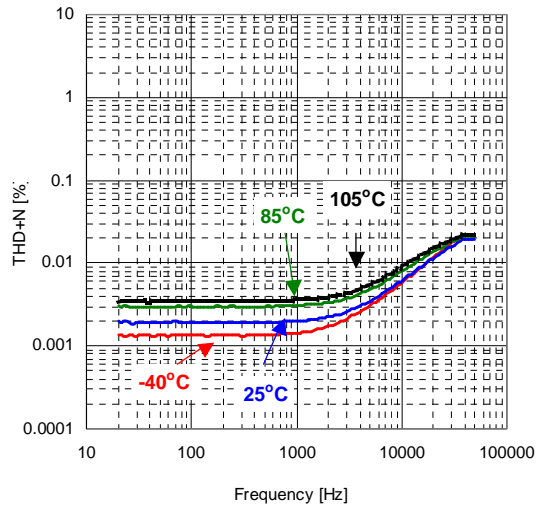

TYPICAL CHARACTERISTICS

Channel Separation vs Frequency

$V^+=3.3V$, $V_o=2V_{rms}$, $R_s=600\Omega$, BW:BandPass, $R_L=10k\Omega$

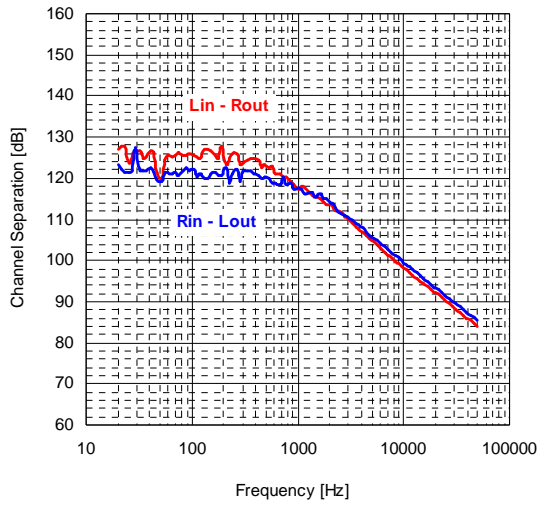

Channel Separation vs Frequency

$V^+=3.3V$, $V_o=2V_{rms}$, $R_s=600\Omega$, BW:BandPass, $R_L=10k\Omega$

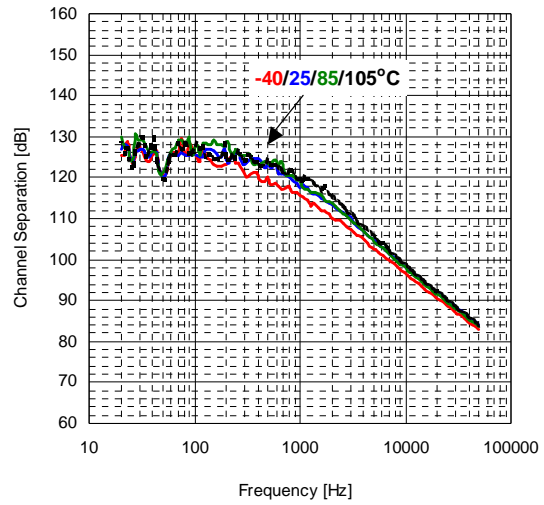

Output Voltage vs Load Resistance

$V^+=3.3V$, $f=1kHz$, THD=1%

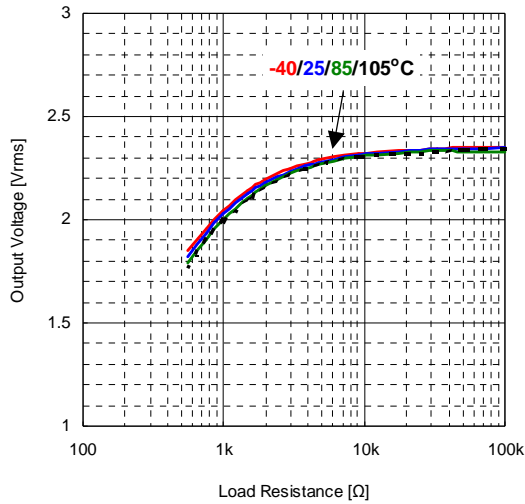

Negative Supply Voltage vs Load Current

$V^+=3.3V$, No Signal, No Load

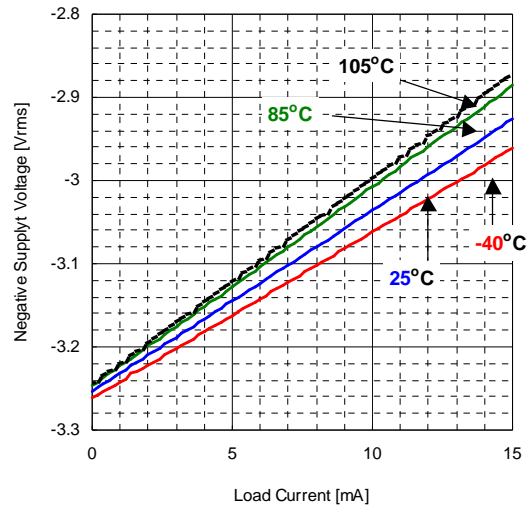

[CAUTION]
The specifications on this databook are only given for information, without any guarantee as regards either mistakes or omissions. The application circuits in this databook are described only to show representative usages of the product and not intended for the guarantee or permission of any right including the industrial rights.

Mouser Electronics

Authorized Distributor

Click to View Pricing, Inventory, Delivery & Lifecycle Information:

[NJR:](#)

[NJU72015](#)



Компания «ЭлектроПласт» предлагает заключение долгосрочных отношений при поставках импортных электронных компонентов на взаимовыгодных условиях!

Наши преимущества:

- Оперативные поставки широкого спектра электронных компонентов отечественного и импортного производства напрямую от производителей и с крупнейших мировых складов;
- Поставка более 17-ти миллионов наименований электронных компонентов;
- Поставка сложных, дефицитных, либо снятых с производства позиций;
- Оперативные сроки поставки под заказ (от 5 рабочих дней);
- Экспресс доставка в любую точку России;
- Техническая поддержка проекта, помощь в подборе аналогов, поставка прототипов;
- Система менеджмента качества сертифицирована по Международному стандарту ISO 9001;
- Лицензия ФСБ на осуществление работ с использованием сведений, составляющих государственную тайну;
- Поставка специализированных компонентов (Xilinx, Altera, Analog Devices, Intersil, Interpoint, Microsemi, Aeroflex, Peregrine, Syfer, Eurofarad, Texas Instrument, Miteq, Cobham, E2V, MA-COM, Hittite, Mini-Circuits, General Dynamics и др.);

Помимо этого, одним из направлений компании «ЭлектроПласт» является направление «Источники питания». Мы предлагаем Вам помощь Конструкторского отдела:

- Подбор оптимального решения, техническое обоснование при выборе компонента;
- Подбор аналогов;
- Консультации по применению компонента;
- Поставка образцов и прототипов;
- Техническая поддержка проекта;
- Защита от снятия компонента с производства.



Как с нами связаться

Телефон: 8 (812) 309 58 32 (многоканальный)

Факс: 8 (812) 320-02-42

Электронная почта: org@eplast1.ru

Адрес: 198099, г. Санкт-Петербург, ул. Калинина, дом 2, корпус 4, литера А.