

HITEK POWER OLH10K SERIES

10KW HIGH VOLTAGE POWER SUPPLIES

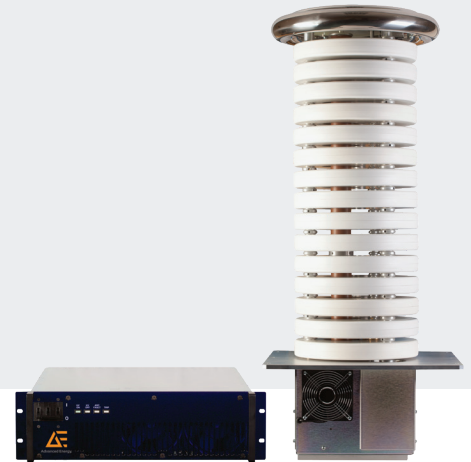

The HiTek Power® OLH10K Series is a range of high reliability single output high voltage power supplies designed to meet the rigorous requirements of ion and electron beam systems, ion implantation and X-ray equipment.

There are three different input voltage variants available to order: the OLH10K (208VAC), the OLH10KC (380VAC) and the OLH10KE (400VAC).

The systems consist of two units: a rack mounting power converter through which both local and remote controls can be facilitated, and a separate HV unit employing a modular disc construction. Numerous features are incorporated to ensure system integrity is maintained during adverse operating conditions, including HiTek Power's unique Arc Count and Extinguish (ACE) system for managing systems where load arcing is endemic.

If none of the models listed below suit your requirements, please contact our Sales Team to discuss a custom version.

PRODUCT HIGHLIGHTS

- 10kW of output power
- Output voltages from 60kV to 500kV
- Robust IGBT converter design
- Exceptional reliability
- High Stability
- Arc Count and Extinguish (ACE)
- Full Local & Remote control and monitoring
- Analogue or RS232 remote control
- Voltage or current control
- RoHS compliant to EU Directive 2002/95/EC
- Custom options available
- CE Marked

ELECTRICAL SPECIFICATIONS

Output Power	10kW maximum at full rated output voltage and current
Output Voltage	Units available with maximum output voltages from 60kV to 500kV
Output Current	Up to 166mA for 60kV and 10mA for 500kV
Input Voltage	OLH10K: 208VAC $\pm 10\%$ (187VAC to 229VAC) 47-63Hz 3 phase plus protective earth
OLH10KC	380VAC $\pm 10\%$ (342VAC to 418VAC) 47-63Hz 3 phase plus protective earth
OLH10KE	400VAC $\pm 10\%$ (360VAC to 440VAC) 47-63Hz 3 phase plus protective earth
Polarity	Positive or negative to order
Minimum Voltage	5% of rated output voltage. The unit may be turned down below this but the specifications are not guaranteed below this level.
Calibration	Calibration between Voltage Demand, Output Voltage and Voltage Monitor $\pm 0.2\%$ of setting or $\pm 0.05\%$ of rating, whichever is greater
Recovery Time	Less than 200ms to within 0.1% of previous operating level following a short circuit or arc. Maximum overshoot 2% of rated output voltage
Temperature Coefficient	Less than 100ppm/ $^{\circ}$ C
Drift	Less than 0.01% per hour after 1 hour's warm up, typically less than 0.02% per 8 hours after 1 hour's warm up, at constant load, line and temperature
Operating Temperature	0 $^{\circ}$ C to +40 $^{\circ}$ C ambient and air intake
Storage Temperature	-20 $^{\circ}$ C to +85 $^{\circ}$ C
Humidity	80% maximum relative humidity up to 31 Deg C, reducing linearly to 50% at 40 Deg C. Non-condensing (ref BS EN61010-1)
Altitude	Sea level to 2000 metres (6500 feet)
Installation Category	II (BS EN61010-1)
Pollution Degree	2 (BS EN61010-1)
Usage	Indoor use only
Protection	The units are fully protected against over voltage, over current, over temperature, load arcing and output short circuits.
Arc Count and Extinguish (ACE)	Each time the ACE system detects an arc it blanks the supply off for a brief period to extinguish the arc. The unit is then allowed to recover. If more arcs occur they are counted to determine the arc rate; if this exceeds a safe level the power supply is shut down. The parameters are factory set to 25 arcs in any 5 second period.
Safety	The OLH10K high voltage power supplies meet the requirements of the Low Voltage Directive, LVD, 2006/95/EC by complying with BS EN61010-1:2001 when installed as a component part of other equipment. They are CE marked accordingly.
Safety Class	Equipment Class 1
EMC ¹	EN55022 class B for conducted and radiated emissions EN61000-4-2 ESD - levels ± 4 kV contact, 8kV air discharge EN61000-4-4 fast transients on mains input - levels ± 2 kV EN61000-4-5 surges - levels ± 2 kV line to earth, ± 1 kV line to line EN61000-4-8 magnetic fields - levels 30A/m at 50/60Hz EN61000-4-11 voltage dips, interruptions
RoHS	The Series OLH10K meets the requirements of EU Directive 2002/95/EC on the Restriction of use of Certain Hazardous Substances in electrical and electronic equipment (RoHS).

¹ The Series OLH10K is intended for installation as a component of a system and is designed to meet
The unit will not trip and recovers to normal operation after a disturbance as defined in SEMI F47-0706.
The EMC performance of the power supply can only be fully assessed when installed within, and as part of, the final system.

ELECTRICAL SPECIFICATIONS (CONTINUEUD)

Input Current	
OLH10K	Less than 36A per phase
OLH10KC	Less than 22A per phase
OLH10KE	Less than 22A per phase
Voltage Ripple	
Voltage Mode	Less than 0.1% of rated voltage +2V, peak to peak or less than 0.02% of rated voltage +1V, rms
Current Mode	Less than 0.5% of rated voltage peak to peak or less than 0.1% of rated voltage rms
Voltage Regulation	
Line	Less than 0.01% +0.5V change in output voltage for a 10% change in line voltage
Load	Less than 0.01% +0.5V change in output voltage for 0 to 100% change in load current
Current Regulation	
Line	Less than 0.5% of rated current for a $\pm 10\%$ change in line voltage
Load	Less than 0.5% of rated current for 0 to 100% change in output voltage
Cooling	
Converter	<p>The unit utilises forced air cooling. Air is drawn in via the front panel slotted opening and through side panel vents. Ensure that within the rack there is a free air opening with a minimum effective area of 195cm² directly in front of the unit front panel slots. An additional free air opening with a minimum effective area of 195m² is required for the side vents. Air flow from this additional free air opening to the side vents of the power converter must not be restricted. The expected air flow for each opening is approximately 50 Litres per second. The maximum temperature of the air entering the units must not exceed 40°C (104°F).</p> <p>The unit can dissipate up to 1kW, therefore provision must be made to extract the exhaust air from the rack in order to prevent possible overheating.</p>
HV Unit	<p>The HV Unit may be mounted in any orientation, but at least 150mm of free space should be allowed around the HV base for air intake/exhaust from the fans. The side panel grilles must not be obstructed. The maximum temperature of air entering the HV base must not exceed 40°C (104°F).</p> <p>Adequate clearance must be allowed around the HV discs to take account of the high voltage output.</p> <p>The HV unit can dissipate up to 1kW, therefore provision must be made to extract air/cool the oil in the HV enclosure in order to prevent possible overheating.</p>

MECHANICAL SPECIFICATIONS

Please contact the Sales Team for 400kV and 500kV mechanical outline details and weights.

Dimensions	60kV-300kV models - see outline drawings attached	
Connections	All connections are mounted on the rear panel	
Mains	Harting Han C (mating part provided)	
Safety Earth	M6 stud on both the converter and HV unit	
HV Output	Direct connection to the top of the HV unit	
Front Panel	Stoving enamel trimite full gloss S60/9 colour blue RAL5011 as standard	
	Blank front panel available to order (see below)	
Weight		
60kV-300kV Converter	27kg	
60kV-300kV Stacks	Output Voltage Variant	HV Stack Weight
	60 kV	31 kg
	80 kV	36 kg
	100 kV	41 kg
	120 kV	46 kg
	140 kV	51 kg
	160 kV	56 kg
	180 kV	61 kg
	200 kV	66 kg
	300 kV	91 kg

MECHANICAL SPECIFICATIONS (CONTINUEUD)

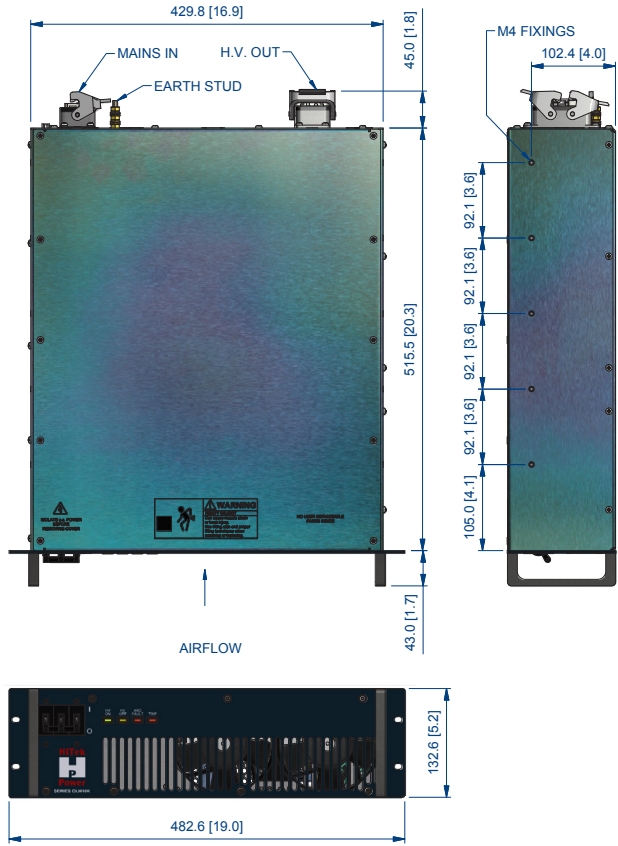

ALL DIMENSIONS - MILLIMETRES [INCHES]

OUTPUT KV	DIM 'A' NOMINAL
60	229.2 [9.0]
80	280.1 [11.0]
100	331.0 [13.0]
120	381.9 [15.0]
140	432.8 [17.0]
160	483.7 [19.0]
180	534.6 [21.0]
200	585.5 [23.1]
300	840.0 [33.1]

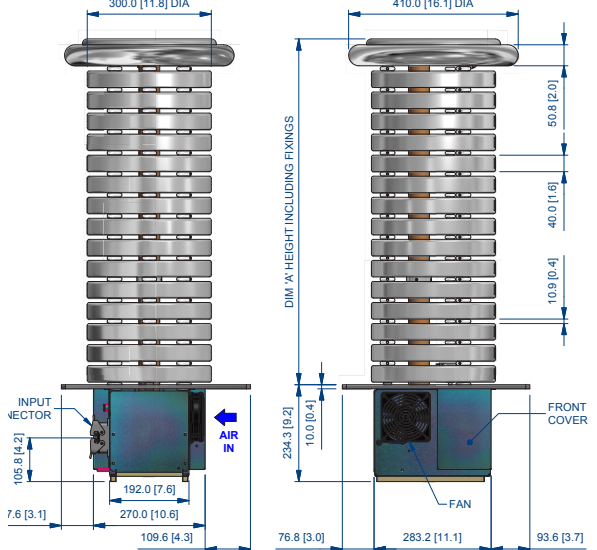
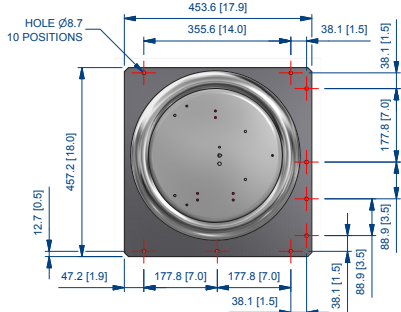

INTERFACE

Remote Control Interface Connections:

The Series OLH10K is fitted with an analogue remote control interface as standard, control is via a 25-way female D-type connector:

V STATUS INDICATOR	1	14	HV OUTPUT CURRENT MONITOR
I STATUS INDICATOR	2	15	HV OFF INDICATOR
HV OUTPUT VOLTAGE MONITOR	3	16	REMOTE INDICATOR
FAULT INDICATOR	4	17	ARC MONITOR INDICATOR
LOCAL INDICATOR	5	18	+10V REFERENCE VOLTAGE
HV ON INDICATOR	6	19	NO CONNECTION
VOLTAGE DEMAND MONITOR	7	20	NO CONNECTION
HV ON/OFF CONTROL Lo	8	21	HV ENABLE Lo
HV ON/OFF CONTROL Hi	9	22	HV ENABLE Hi
VOLTAGE DEMAND Hi	10	23	CURRENT DEMAND Lo
VOLTAGE DEMAND Lo	11	24	CURRENT DEMAND Hi
0V MONITOR 0V	12	25	NO CONNECTION

All logical indicators are open collector outputs rated at 16V (max) in the off state. An internal 100Ω resistor is connected in series with the open collector transistor. The pull down voltage is 0.9V plus the internal resistor drop.

All analogue Voltage and Current Monitors are 0V to +10V ±0.5% ±20mV, with respect to pin 13, representing 0 to rated output. Signal impedance is less than 100Ω and minimum external load resistance is 2kΩ.

All analogue Voltage and Current Inputs are 0V to +10V on the Hi input with respect to the Lo input representing 0V to rated output ±0.2% of setting ±0.1% of rating. Input impedance is better than 50kΩ.

Digital RS232 Remote Control 9-way female D-type connector:

NO CONNECTION	1	6	NO CONNECTION
TXD TRANSMIT DATA	2	7	NO CONNECTION
RXD RECEIVE DATA	3	8	NO CONNECTION
NO CONNECTION	4	9	NO CONNECTION
SIGNAL GROUND	5		

The Series OLH10K is configured as a DCE device. To connect to a PC or other DTE device, use a 'pin-pin' DB9 female to male serial cable.

The communication is set to 9,600 Baud, one start bit, one stop bit and no parity. The connector shell can be connected to earth and cable screen. A comprehensive set of commands is available for the control and monitoring of the power supply.

ORDERING INFORMATION

Model 208VAC Input	Model 380VAC Input	Model 400VAC Input	Output Voltage	Output Current
OLH10K-603 ¹	OLH10KC-603 ¹	OLH10KE-603 ¹	60kV	166mA
OLH10K-803 ¹	OLH10KC-803 ¹	OLH10KE-803 ¹	80kV	120mA
OLH10K-104 ¹	OLH10KC-104 ¹	OLH10KE-104 ¹	100kV	100mA
OLH10K-124 ¹	OLH10KC-124 ¹	OLH10KE-124 ¹	120kV	80 mA
OLH10K-144 ¹	OLH10KC-144 ¹	OLH10KE-144 ¹	140kV	65mA
OLH10K-164 ¹	OLH10KC-164 ¹	OLH10KE-164 ¹	160kV	55mA
OLH10K-184 ¹	OLH10KC-184 ¹	OLH10KE-184 ¹	180kV	45mA
OLH10K-204 ¹	OLH10KC-204 ¹	OLH10KE-204 ¹	200kV	40mA
OLH10K-304 ¹	OLH10KC-304 ¹	OLH10KE-304 ¹	300kV	15mA
OLH10K-404 ¹	OLH10KC-404 ¹	OLH10KE-404 ¹	400kV	10mA
OLH10K-504 ¹	OLH10KC-504 ¹	OLH10KE-504 ¹	500kV	10mA

¹ Please add the required suffix to the part number:

P Positive polarity

N Negative polarity

B Blank front panel (remote control only)

C RS232 control interface

eg order part number OLH10K-803PB for an 80kV positive polarity unit with blank front panel.

For voltages not listed above, please contact our sales team.

The attached outline drawings are only applicable to 60kV-300kV model variants. Please contact our Sales Team for mechanical information on the 400kV and 500kV models.

See separate datasheet on our Series OLH10KD for dual voltage range capability with accurate control and low ripple down to 1% of maximum rated output. Other voltages and combinations are available to special order.



For international contact information,
visit advanced-energy.com.

HVSales@aei.com
+1.970.221.0108

ABOUT ADVANCED ENERGY

Since 1981, Advanced Energy (AE) has perfected how power performs for its customers. For both end users and OEMs, AE's comprehensive portfolio of standard and custom high voltage components precisely match system specifications to deliver unparalleled energy, quality, and performance. Through close customer collaboration, design expertise, application insight, and world-class support, AE creates successful partnerships and enables customers to push the boundaries of innovation and stay ahead of evolving market needs.

PRECISION | POWER | PERFORMANCE



CAUTION:
High Voltage

Read and understand all documentation before you install, operate, or maintain Advanced Energy high voltage power supplies. Follow all safety instructions and precautions to protect against property damage and serious or possibly fatal bodily injury. Never defeat safety interlocks or grounds.

Specifications are subject to change without notice. Not responsible for errors or omissions. ©2018 Advanced Energy Industries, Inc. All rights reserved. Advanced Energy®, AE®, and HiTek Power® are U.S. trademarks of Advanced Energy Industries, Inc.





Компания «ЭлектроПласт» предлагает заключение долгосрочных отношений при поставках импортных электронных компонентов на взаимовыгодных условиях!

Наши преимущества:

- Оперативные поставки широкого спектра электронных компонентов отечественного и импортного производства напрямую от производителей и с крупнейших мировых складов;
- Поставка более 17-ти миллионов наименований электронных компонентов;
- Поставка сложных, дефицитных, либо снятых с производства позиций;
- Оперативные сроки поставки под заказ (от 5 рабочих дней);
- Экспресс доставка в любую точку России;
- Техническая поддержка проекта, помощь в подборе аналогов, поставка прототипов;
- Система менеджмента качества сертифицирована по Международному стандарту ISO 9001;
- Лицензия ФСБ на осуществление работ с использованием сведений, составляющих государственную тайну;
- Поставка специализированных компонентов (Xilinx, Altera, Analog Devices, Intersil, Interpoint, Microsemi, Aeroflex, Peregrine, Syfer, Eurofarad, Texas Instrument, Miteq, Cobham, E2V, MA-COM, Hittite, Mini-Circuits, General Dynamics и др.);

Помимо этого, одним из направлений компании «ЭлектроПласт» является направление «Источники питания». Мы предлагаем Вам помощь Конструкторского отдела:

- Подбор оптимального решения, техническое обоснование при выборе компонента;
- Подбор аналогов;
- Консультации по применению компонента;
- Поставка образцов и прототипов;
- Техническая поддержка проекта;
- Защита от снятия компонента с производства.



Как с нами связаться

Телефон: 8 (812) 309 58 32 (многоканальный)

Факс: 8 (812) 320-02-42

Электронная почта: org@eplast1.ru

Адрес: 198099, г. Санкт-Петербург, ул. Калинина, дом 2, корпус 4, литера А.