

C3D04060F–silicon Carbide Schottky Diode

Z-REC™ RECTIFIER (FULL-PAK)

| | |
|--------------|----------|
| V_{RRM} | = 600 V |
| $I_{F(AVG)}$ | = 4 A |
| Q_c | = 8.5 nC |

Features

- 600-Volt Schottky Rectifier
- Optimized for PFC Boost Diode Application
- Zero Reverse Recovery Current
- Zero Forward Recovery Voltage
- High-Frequency Operation
- Temperature-Independent Switching Behavior
- Extremely Fast Switching
- Positive Temperature Coefficient on V_F
- Fully Isolated Case

Benefits

- Replace Bipolar with Unipolar Rectifiers
- Essentially No Switching Losses
- Higher Efficiency
- Reduction of Heat Sink Requirements
- Parallel Devices Without Thermal Runaway
- No Additional Isolation Required

Applications

- Switch Mode Power Supplies
- Power Factor Correction
 - Typical PFC P_{out} : 150W-300W
- Motor Drives

Package

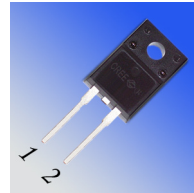

TO-220-F2



| Part Number | Package | Marking |
|-------------|-----------|----------|
| C3D04060F | TO-220-F2 | C3D04060 |

Maximum Ratings

| Symbol | Parameter | Value | Unit | Test Conditions | Note |
|----------------|--|----------------|------------------|---|------|
| V_{RRM} | Repetitive Peak Reverse Voltage | 600 | V | | |
| V_{RSM} | Surge Peak Reverse Voltage | 600 | V | | |
| V_{DC} | DC Blocking Voltage | 600 | V | | |
| $I_{F(AVG)}$ | Average Forward Current | 4 | A | $T_c=95^\circ\text{C}$, DC | |
| I_{FRM} | Repetitive Peak Forward Surge Current | 21 13 | A | $T_c=25^\circ\text{C}$, $t_p = 10$ ms, Half Sine Wave, $D=0.3$ $T_c=110^\circ\text{C}$, $t_p = 10$ ms, Half Sine Wave, $D=0.3$ | |
| I_{FSM} | Non-Repetitive Peak Forward Surge Current | 30 25 | A | $T_c=25^\circ\text{C}$, $t_p = 10$ ms, Half Sine Wave, $D=0.3$ $T_c=110^\circ\text{C}$, $t_p = 10$ ms, Half Sine Wave, $D=0.3$ | |
| I_{FSM} | Non-Repetitive Peak Forward Surge Current | 110 | A | $T_c=25^\circ\text{C}$, $t_p = 10$ μs , Pulse | |
| P_{tot} | Power Dissipation | 13.1 5.7 | W | $T_c=25^\circ\text{C}$ $T_c=110^\circ\text{C}$ | |
| T_j, T_{stg} | Operating Junction and Storage Temperature | -55 to +175 | $^\circ\text{C}$ | | |
| | TO-220 Mounting Torque | 1 8.8 | Nm lbf-in | M3 Screw 6-32 Screw | |

Electrical Characteristics

| Symbol | Parameter | Typ. | Max. | Unit | Test Conditions | Note |
|--------|-------------------------|-----------------|------------|---------------|--|------|
| V_F | Forward Voltage | 1.5 1.8 | 1.7 2.4 | V | $I_F = 4\text{ A}$ $T_J = 25^\circ\text{C}$ $I_F = 4\text{ A}$ $T_J = 175^\circ\text{C}$ | |
| I_R | Reverse Current | 10 20 | 50 100 | μA | $V_R = 600\text{ V}$ $T_J = 25^\circ\text{C}$ $V_R = 600\text{ V}$ $T_J = 175^\circ\text{C}$ | |
| Q_C | Total Capacitive Charge | 8.5 | | nC | $V_R = 600\text{ V}$, $I_F = 4\text{ A}$ $di/dt = 500\text{ A}/\mu\text{s}$ $T_J = 25^\circ\text{C}$ | |
| C | Total Capacitance | 251 22 21 | | pF | $V_R = 0\text{ V}$, $T_J = 25^\circ\text{C}$, $f = 1\text{ MHz}$ $V_R = 200\text{ V}$, $T_J = 25^\circ\text{C}$, $f = 1\text{ MHz}$ $V_R = 400\text{ V}$, $T_J = 25^\circ\text{C}$, $f = 1\text{ MHz}$ | |

Note:

1. This is a majority carrier diode, so there is no reverse recovery charge.

Thermal Characteristics

| Symbol | Parameter | Typ. | Unit |
|-----------------|--|------|---------------------------|
| $R_{\theta JC}$ | Thermal Resistance from Junction to Case | 11.5 | $^\circ\text{C}/\text{W}$ |

Typical Performance

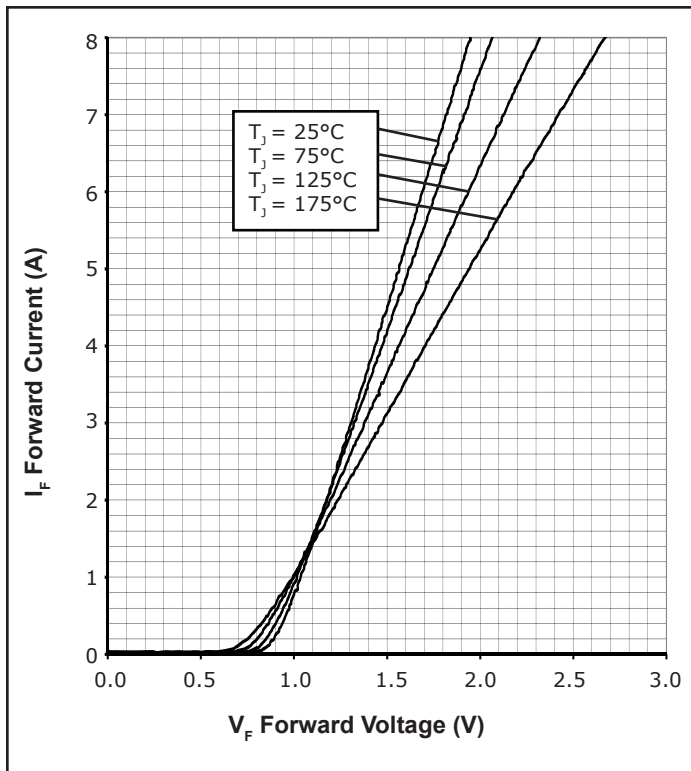

Figure 1. Forward Characteristics

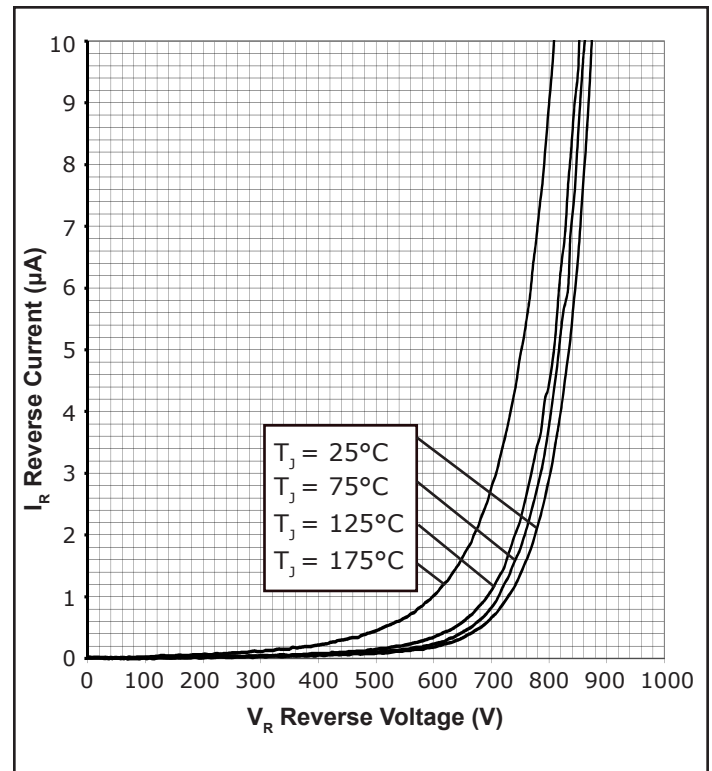

Figure 2. Reverse Characteristics

Typical Performance

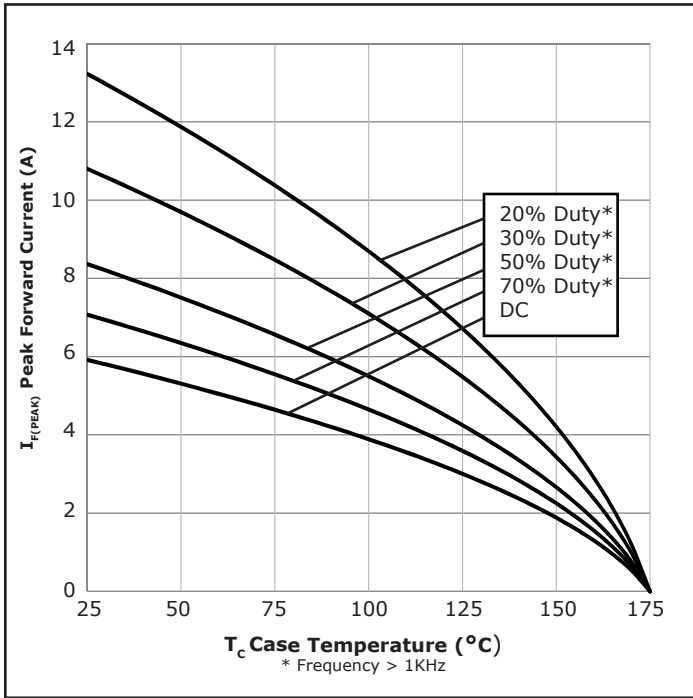

Figure 3. Current Derating

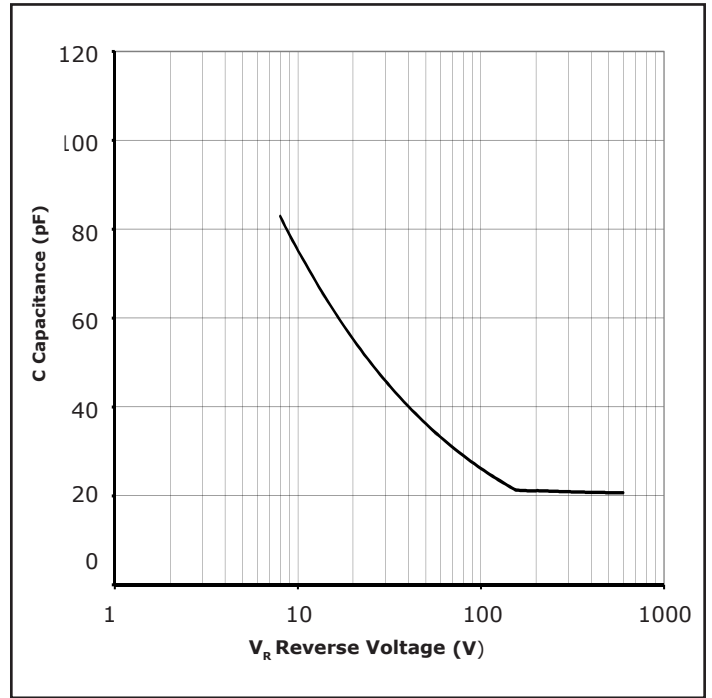

Figure 4. Capacitance vs. Reverse Voltage

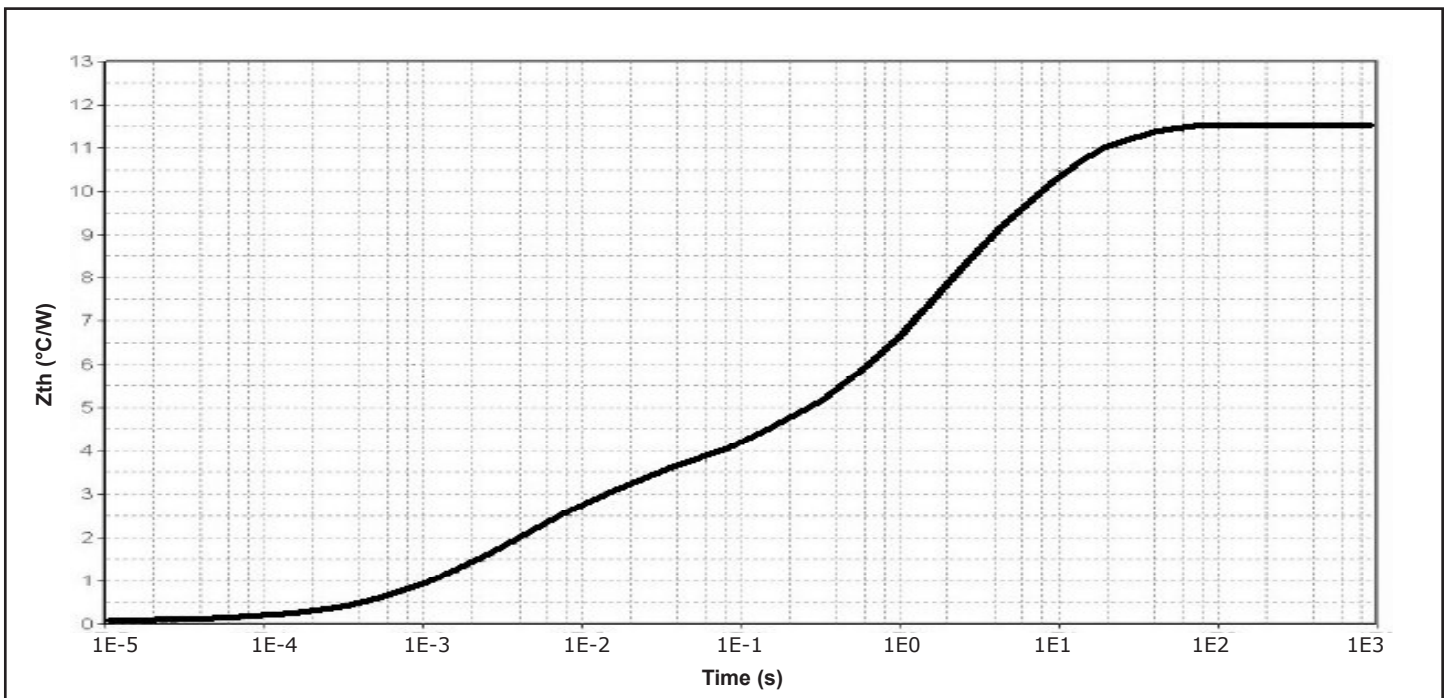

Figure 5. Transient Thermal Impedance

Typical Performance

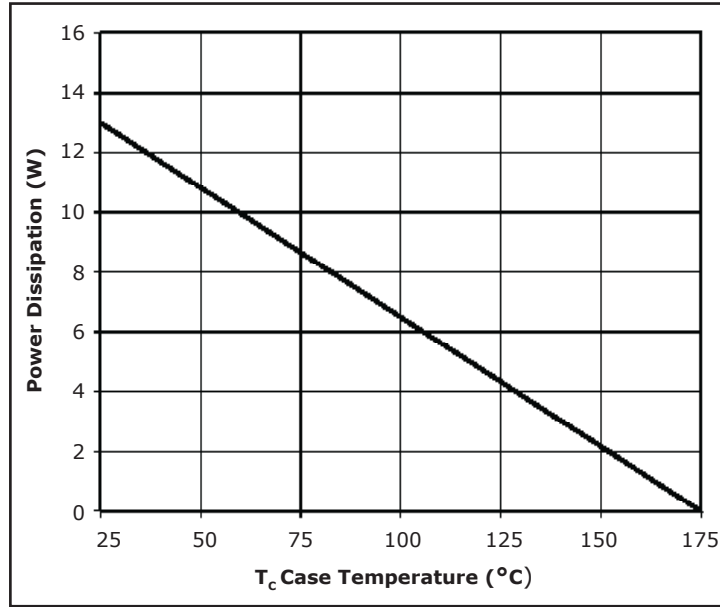
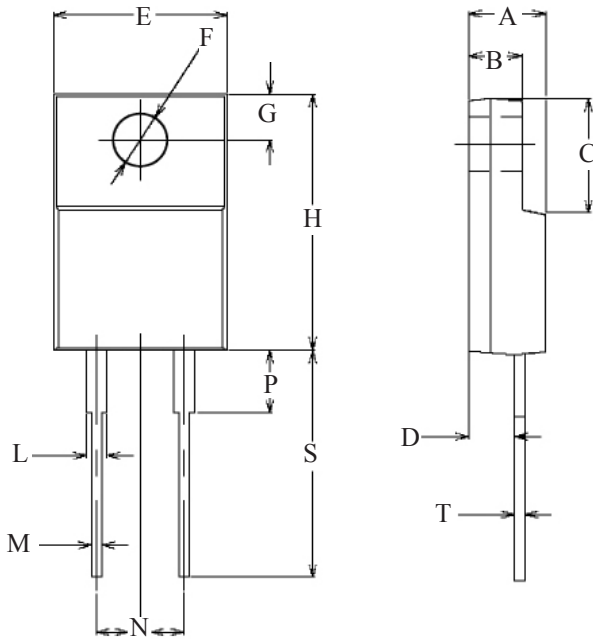

Figure 6. Power Derating

Package Dimensions

Package TO-220-F2



| POS | Inches | | Millimeters | |
|-----|--------|------|-------------|-------|
| | Min | Max | Min | Max |
| A | .177 | .193 | 4.5 | 4.9 |
| B | .092 | .108 | 2.34 | 2.74 |
| C | .248 | .272 | 6.3 | 6.9 |
| D | .098 | .114 | 2.5 | 2.9 |
| E | .390 | .406 | 9.9 | 10.3 |
| F | .118 | .134 | 3.0 | 3.4 |
| G | .122 | .137 | 3.1 | 3.5 |
| H | .617 | .633 | 15.67 | 16.07 |
| L | .039 | .055 | 1.0 | 1.4 |
| M | .016 | .031 | 0.4 | 0.8 |
| N | .185 | .217 | 4.7 | 5.5 |
| P | 0 | .154 | 0 | 3.9 |
| S | .476 | .508 | 12.1 | 12.9 |
| T | .016 | .031 | 0.4 | 0.8 |

NOTE:

1. Dimension L, M, T apply for Solder Dip Finish



Recommended Solder Pad Layout

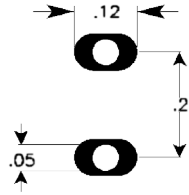

TO-220-F2

| Part Number | Package | Marking |
|-------------|-----------|----------|
| C3D04060F | TO-220-F2 | C3D04060 |

Diode Model

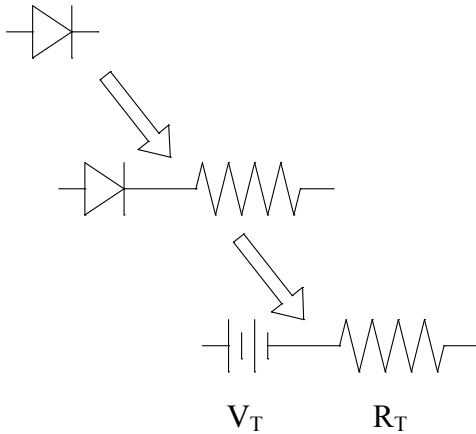

$$V_{fT} = V_T + I_f * R_T$$

$$V_T = 0.98 + (T_j * -1.8 * 10^{-3})$$

$$R_T = 0.10 + (T_j * 9.16 * 10^{-4})$$

Note: T_j = Diode Junction Temperature In Degrees Celcius

"The levels of environmentally sensitive, persistent biologically toxic (PBT), persistent organic pollutants (POP), or otherwise restricted materials in this product are below the maximum concentration values (also referred to as the threshold limits) permitted for such substances, or are used in an exempted application, in accordance with EU Directive 2002/95/EC on the restriction of the use of certain hazardous substances in electrical and electronic equipment (RoHS), as amended through April 21, 2006.

This product has not been designed or tested for use in, and is not intended for use in, applications implanted into the human body nor in applications in which failure of the product could lead to death, personal injury or property damage, including but not limited to equipment used in the operation of nuclear facilities, life-support machines, cardiac defibrillators or similar emergency medical equipment, aircraft navigation or communication or control systems, air traffic control systems, or weapons systems.

Copyright © 2009-2011 Cree, Inc. All rights reserved. The information in this document is subject to change without notice. Cree and the Cree logo are registered trademarks and Z-Rec is a trademark of Cree, Inc.

Cree, Inc.
4600 Silicon Drive
Durham, NC 27703
USA Tel: +1.919.313.5300
Fax: +1.919.313.5451
www.cree.com/power



Компания «ЭлектроПласт» предлагает заключение долгосрочных отношений при поставках импортных электронных компонентов на взаимовыгодных условиях!

Наши преимущества:

- Оперативные поставки широкого спектра электронных компонентов отечественного и импортного производства напрямую от производителей и с крупнейших мировых складов;
- Поставка более 17-ти миллионов наименований электронных компонентов;
- Поставка сложных, дефицитных, либо снятых с производства позиций;
- Оперативные сроки поставки под заказ (от 5 рабочих дней);
- Экспресс доставка в любую точку России;
- Техническая поддержка проекта, помощь в подборе аналогов, поставка прототипов;
- Система менеджмента качества сертифицирована по Международному стандарту ISO 9001;
- Лицензия ФСБ на осуществление работ с использованием сведений, составляющих государственную тайну;
- Поставка специализированных компонентов (Xilinx, Altera, Analog Devices, Intersil, Interpoint, Microsemi, Aeroflex, Peregrine, Syfer, Eurofarad, Texas Instrument, Miteq, Cobham, E2V, MA-COM, Hittite, Mini-Circuits, General Dynamics и др.);

Помимо этого, одним из направлений компании «ЭлектроПласт» является направление «Источники питания». Мы предлагаем Вам помощь Конструкторского отдела:

- Подбор оптимального решения, техническое обоснование при выборе компонента;
- Подбор аналогов;
- Консультации по применению компонента;
- Поставка образцов и прототипов;
- Техническая поддержка проекта;
- Защита от снятия компонента с производства.



Как с нами связаться

Телефон: 8 (812) 309 58 32 (многоканальный)

Факс: 8 (812) 320-02-42

Электронная почта: org@eplast1.ru

Адрес: 198099, г. Санкт-Петербург, ул. Калинина, дом 2, корпус 4, литера А.