

## Lighted Pushbutton Switch

## A3D

### Cylindrical 8-dia. Subminiature Series Feature Short Mounting Depth

- Round, square, and rectangular LED pushbutton units
- Models that can be used as an indicator also available.
- Requires only 18-mm mounting depth
- Efficiency in wiring improved by terminals arranged on the same surface.
- Lenses and legends replaceable without tools

## Ordering Information

When placing your order, specify the individual component part model numbers of the pushbutton unit, LED, lamp, and switch unit, as listed in the ordering tables below.

### Lighted Type Pushbutton Unit

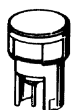

A3Dj -500j  
M2Dj -500j \*

### Switch Unit



A3Dj -7j j j  
M2Dj -7j j j \*

\* Model number unique for indicator unit

### Non-lighted Type Pushbutton Unit



A3Dj -501j

### Switch Unit



A3D-7j j j

### Pushbutton Unit



#### Lighted Type, Built-in LED

Button color	Rectangular	Square	Round
<b>Red</b>	A3DJ-500R	A3DA-500R	A3DT-500R
<b>Yellow</b>	A3DJ-500Y	A3DA-500Y	A3DT-500Y
<b>Green</b>	A3DJ-500GY	A3DA-500GY	A3DT-500GY
<b>White</b>	A3DJ-500W	A3DA-500W	A3DT-500W

#### Indicator

Button color	Rectangular	Square	Round
<b>Red</b>	M2DJ-500R	M2DA-500R	M2DT-500R
<b>Yellow</b>	M2DJ-500Y	M2DA-500Y	M2DT-500Y
<b>Green</b>	M2DJ-500GY	M2DA-500GY	M2DT-500GY
<b>White</b>	M2DJ-500W	M2DA-500W	M2DT-500W

## Switch Unit

Contact configuration	Switch action	Terminal	Degree of protection: IP00		
			Rectangular	Square	Round
SPST-NO+ SPST-NC	Momentary	Solder	 A3DJ-7111	 A3DA-7111	 A3DT-7111
		PCB	A3DJ-7112	A3DA-7112	A3DT-7112
	Alternate	Solder	A3DJ-7121	A3DA-7121	A3DT-7121
		PCB	A3DJ-7122	A3DA-7122	A3DT-7122
For indication (no switch)		Solder	M2DJ-7001	M2DA-7001	M2DT-7001
		PCB	M2DJ-7002	M2DA-7002	M2DT-7002

## Specifications

## Contact Ratings

DC (resistive load)	0.1 A, 30 VDC.
---------------------	----------------

**Note:** The minimum permissible load is 1 mA, 5 VDC.

## Built-in LED Ratings

Item		Red	Yellow	Green
Forward voltage $V_F$	Standard value (see note)	1.7 V	2.2 V	1.7 V
	Max. value	2.0 V	2.5 V	2.0 V
Forward current $I_F$	Standard value	20 mA	20 mA	20 mA
	Absolute max. value	50 mA	50 mA	50 mA
Permissible loss $P_D$	Absolute max. value	100 mW	125 mW	122 mW
Reverse voltage $V_R$	Absolute max. value	4 V	4 V	4 V

**Note:** Refer to  $V_F$  vs.  $I_F$  characteristics in Hints on Correct Use. Because no resistor is incorporated in the built-in LED, connect an appropriate external resistance within the above limit.

## Characteristics

Operating frequency	Mechanical: Momentary-action type: 120 operations per minute max. Alternate-action type: 60 operations per minute max. Electrical: 20 operations per minute max.
Insulation resistance	100 M $\Omega$ min. (at 500 VDC)
Dielectric strength	1,000 VAC, 50/60 Hz for 1 minute between terminals of same polarity 2,000 VAC, 50/60 Hz for 1 minute between terminals of different polarity and also between each terminal and ground
Vibration	Mechanical/malfunction durability: 10 to 55 Hz, 1.5 mm double amplitude
Shock	Mechanical durability: 500 m/s <sup>2</sup> (approx. 50 G) Malfunction durability: 150 m/s <sup>2</sup> (approx. 15 G)
Ambient temperature	Operating: -10_ to 55_C
Humidity	35 to 85% RH
Life expectancy	Mechanical: Momentary-action type: 1,000,000 operations min. Alternate-action type: 100,000 operations min. Electrical: 100,000 operations per minute max.
Weight	Approx. 3 g (see note)

**Note:** The weight indicated here applies to the lighted type (SPST-NO).

Applicable Load Range

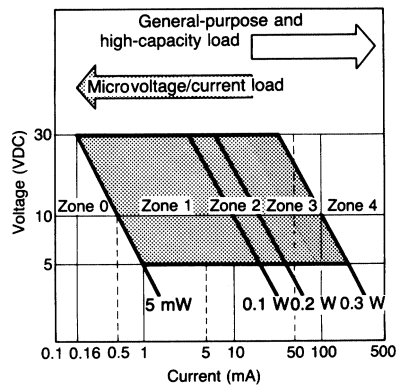

OF max.	250 g
RF min.	20 g
TT	3.5±0.5 mm
LTA min.	0.5 mm
PT max.	2.5 mm

# Dimensions

Unless otherwise specified, a tolerance of  $\pm 0.4$  mm applies to all dimensions.

The following dimensions apply to the switch unit with solder terminals.

## Rectangular A3DJ

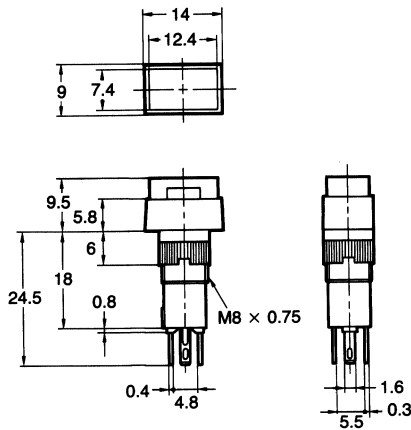

### Panel cutout

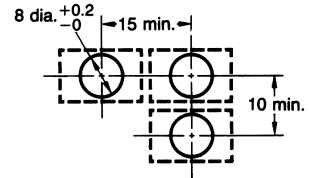

Note: Recommended panel thickness is 1.0 to 3.2 mm.

## Square A3DA

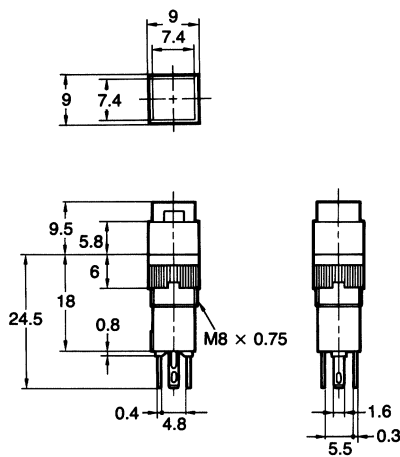

### Panel cutout

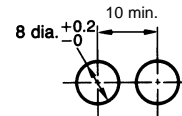

Note: Recommended panel thickness is 1.0 to 3.2 mm.

## Round A3DT

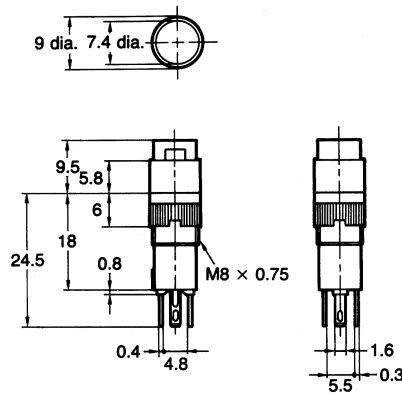

## Legend Plate A3DJ

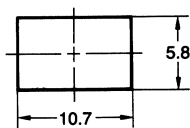

## A3DA

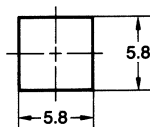

## A3DT

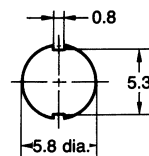



- Note:**
1. The thickness is 0.8 mm.
  2. Since the legend plate is made of polycarbonate, use alcohol-based paints such as melanin, phthalic acid, or acryl paint when marking the legend.

# Terminals/Connections

	Type	
	SPST-NO	Indicator
<b>Solder terminal</b>	<p><b>Lighted type, non-lighted type</b></p> <p><b>Terminal hole</b></p>	<p><b>Indicator</b></p> <p><b>Terminal hole</b></p>
<b>PCB terminal</b>	<p><b>Lighted type, non-lighted type</b></p> <p><b>Mounting hole (bottom view)</b></p>	<p><b>Indicator</b></p> <p><b>Mounting hole (bottom view)</b></p>

# Accessories (Order Separately)

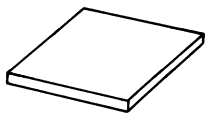
Name	Shape	Classification	Model	Remarks
Socket		Wire-wrap terminal	A3D-4101	Cannot be used with insulation cover.
		PCB terminal	A3D-4102	
		Solder terminal	A3D-4103	
Insulation Cover		---	A3D-3002	Cannot be used with socket.
Tightening Tool		---	A3D-3004	Useful for mounting switch units one after another. Do not over-tighten.
Legend Plate		Rectangular	A3DJ-5201	One legend plate is supplied per standard switch unit.
		Square	A3DA-5201	
		Round	A3DT-5201	

## Dimensions with Socket

### Wire-wrap Terminal

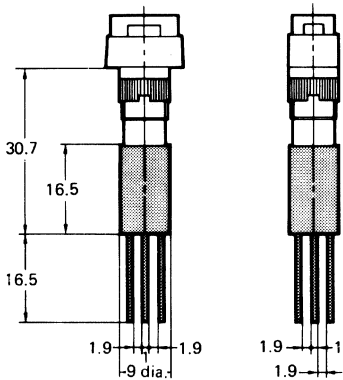

### PCB Terminal

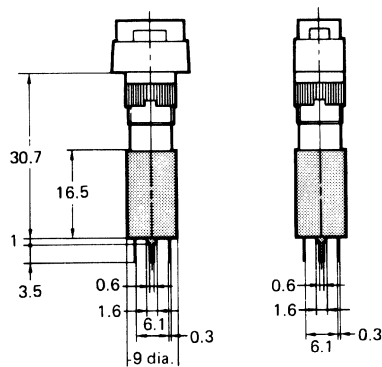

### Solder Terminal

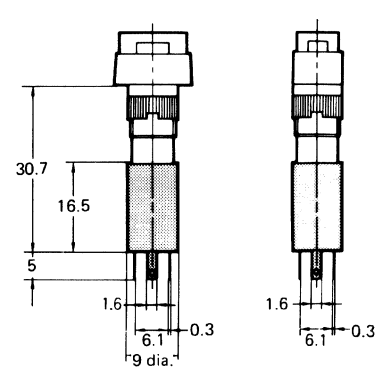

### Mounting Hole (Bottom View)

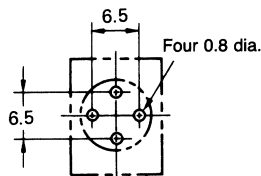

## Dimensions with Insulation Cover

The illustration below shows the insulation cover fitted to a rectangular pushbutton switch.

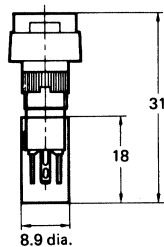

Mount the switch unit on the panel with the mounting nut. To perform the wiring, first insert the lead wires into the hole of the insulation cover. Mount the insulation cover to the switch so that the side of the cover having a cylindrical hole faces the switch unit. Insert the lead wire in the insulation cover from the side of the insulation cover having a barrier.

After performing the wiring, mount the insulation cover to the switch so that the projection of the switch fits in the hole on the insulation cover.

# Assembly/Disassembly

## Mounting Directions for Switch and Pushbutton Unit

- Insert the pushbutton unit in the switch unit so that the circular-shaped claw outside the projection of the switch unit mates with the claw on the upper part of the switch unit.
- The pressure applied during insertion should be 2.5 kg max.

**Note:** If the LED terminal is bent, it may not align with the mating hole. Before insertion, check to see if any LED terminal is bent and, if so, straighten it.

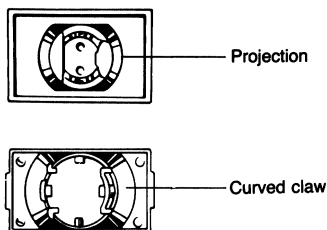

## Mounting Switch Unit on Panel

### Nut Mounting

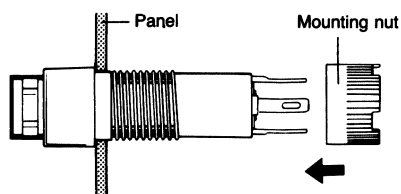

## Wiring

- Finish soldering within 5 seconds with a 30 watt soldering iron, or within 3 seconds at a solder temperature of 240\_C. For about a minute after soldering, do not apply any force to the switch unit to avoid deforming the softened plastic switch unit base.
- Use a non-corrosive, resin-based soldering flux.

## Construction

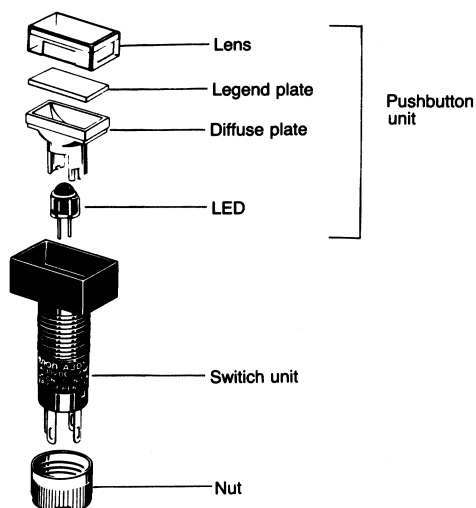

## Removing the Pushbutton Unit

- With your thumb and forefinger, while holding the recessed portions on both sides, firmly and steadily pull out the top of the pushbutton unit. Pulling out the cap with pliers or a similar tool will damage the cap.

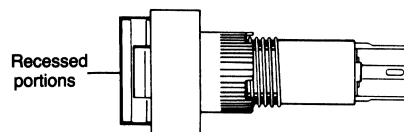

- Insert the switch unit from the front of the panel and tighten the mounting nut inserted from the rear of the panel.
- Since a projection exists on the rear portion of the switch unit, if the mounting nut cannot be fitted into position, turn the nut slightly.
- The tightening torque of the mounting nut should be less than 5 kg-cm.
- Solder the terminals after mounting the nut. Otherwise, the terminals, when thickened by solder, may prevent the nut from being screwed down onto the switch unit.

# Hints on Correct Use

## LED

- Because no resistor is incorporated in the LED of the lighted pushbutton switch, connect an appropriate external resistor.
- Make sure that the resistance of the resistor is within the permissible range determined by the LED characteristics. The forward current of the LED must be 8 mA minimum.
- The resistance of the external resistor can be obtained by this equation:

$$R = E - V_F / I_F (\Omega)$$

where,

E: operating voltage (V)

$V_F$ : LED forward voltage (V)

$I_F$ : LED forward current (mA)

Determine the resistance of the external resistor that satisfies the characteristics of the LED. However, the average LED forward current must be 8 mA or more.

Example of resistance calculation

When using a red LED where  $E = 24 \text{ V}$ ,  $I_F = 20 \text{ mA}$ , and  $T_a = 25^\circ\text{C}$ , from the  $V_F$  vs.  $I_F$  characteristics on the right, forward voltage  $V_F$  is 1.7 V

when 20 mA of  $I_F$  flows through the LED. Substituting these values for the variables in the above equation,

$$R = \frac{24 \text{ (V)} - 1.7 \text{ (V)}}{0.02 \text{ (A)}} = 1111.5 \text{ } (\Omega) \text{ (or } 20 \text{ mA) (or } 1.1 \text{ k}\Omega)$$

Therefore, the estimated resistance is 1.1 k $\Omega$ , 1W.

**Decrease in Forward Current**

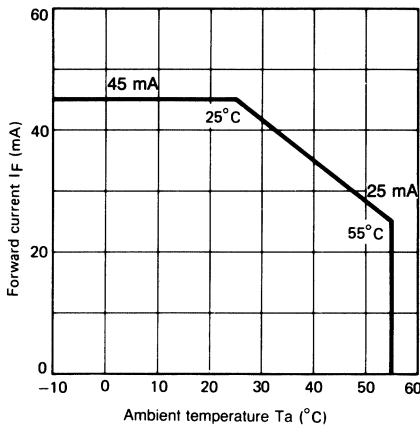

**LED Characteristics (VF vs. IF Characteristics) (Red)**

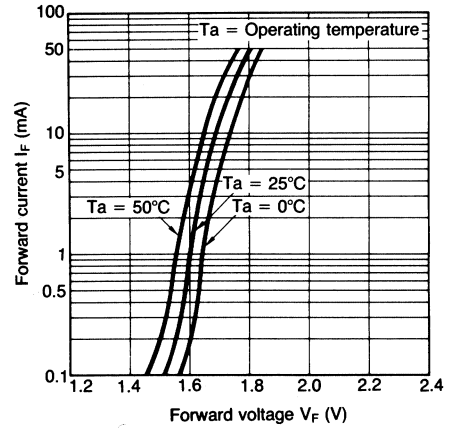

**LED Characteristics (VF vs. IF Characteristics) (Yellow)**

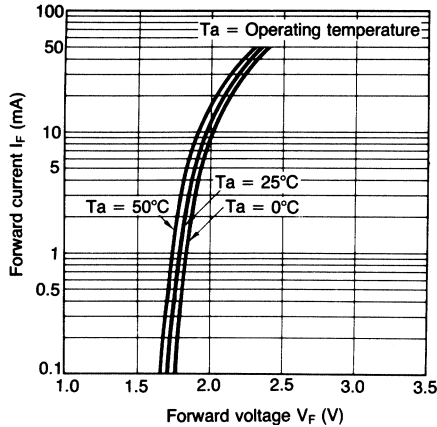

**LED Characteristics (VF vs. IF Characteristics) (Green)**

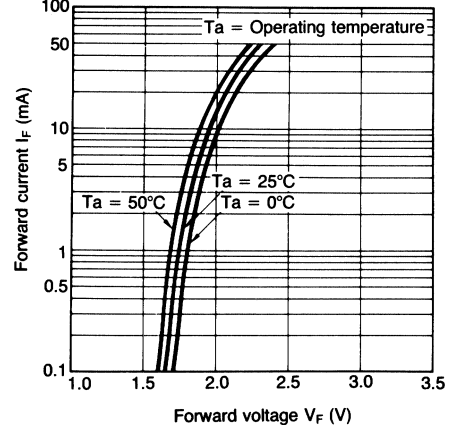

**ALL DIMENSIONS SHOWN ARE IN MILLIMETERS.**  
 To convert millimeters into inches, multiply by 0.03937. To convert grams into ounces, multiply by 0.03527.





Компания «ЭлектроПласт» предлагает заключение долгосрочных отношений при поставках импортных электронных компонентов на взаимовыгодных условиях!

Наши преимущества:

- Оперативные поставки широкого спектра электронных компонентов отечественного и импортного производства напрямую от производителей и с крупнейших мировых складов;
- Поставка более 17-ти миллионов наименований электронных компонентов;
- Поставка сложных, дефицитных, либо снятых с производства позиций;
- Оперативные сроки поставки под заказ (от 5 рабочих дней);
- Экспресс доставка в любую точку России;
- Техническая поддержка проекта, помощь в подборе аналогов, поставка прототипов;
- Система менеджмента качества сертифицирована по Международному стандарту ISO 9001;
- Лицензия ФСБ на осуществление работ с использованием сведений, составляющих государственную тайну;
- Поставка специализированных компонентов (Xilinx, Altera, Analog Devices, Intersil, Interpoint, Microsemi, Aeroflex, Peregrine, Syfer, Eurofarad, Texas Instrument, Miteq, Cobham, E2V, MA-COM, Hittite, Mini-Circuits, General Dynamics и др.);

Помимо этого, одним из направлений компании «ЭлектроПласт» является направление «Источники питания». Мы предлагаем Вам помощь Конструкторского отдела:

- Подбор оптимального решения, техническое обоснование при выборе компонента;
- Подбор аналогов;
- Консультации по применению компонента;
- Поставка образцов и прототипов;
- Техническая поддержка проекта;
- Защита от снятия компонента с производства.



#### Как с нами связаться

**Телефон:** 8 (812) 309 58 32 (многоканальный)

**Факс:** 8 (812) 320-02-42

**Электронная почта:** [org@eplast1.ru](mailto:org@eplast1.ru)

**Адрес:** 198099, г. Санкт-Петербург, ул. Калинина, дом 2, корпус 4, литера А.