



SANYO Semiconductors

DATA SHEET

An ON Semiconductor Company

LV8417CS — Bi-CMOS IC Forward/Reverse Motor Driver

Overview

The LV8417CS is a 1-channel H bridge motor driver IC. The package size is extremely small with wafer level package (WLP). Moreover, the on-resistance is low (upper and lower total 0.27Ω typ.).

The application voltage range is wide (2.0V to 10.5V).

The H bridge of this IC is P-N composition and thereby reduces the external parts without need of charge pump.

Therefore, LV8417CS realizes reduction of mounting area which enables lower cost and smaller application size.

Functions

- H-bridge 1-channel forward/reverse motor driver
- BiCDMOS process
- Output ON resistance (Upper and lower total 0.27Ω; Ts=25°C, IO=1.0A)
- IO max=1.0A (t≤100ms 2.0A, t≤10ms 3.8A)
- Built-in low voltage reset and thermal shutdown circuit

Specifications

Maximum Ratings at Ta = 25°C, SGND = PGND = 0V

Parameter	Symbol	Conditions	Ratings	Unit
Power supply voltage (for load)	V _M max		-0.5 to 12.6	V
Power supply voltage (for control)	V _{CC} max		-0.5 to 6.0	V
Output current	I _O max		1.0	A
Output peak current	I _O peak1	t ≤ 100ms	2.0	A
	I _O peak2	t ≤ 10ms	3.8	A
Input voltage	V _{IN} max		-0.5 to V _{CC} +0.5	V
Allowable power dissipation	P _d max	Mounted on a specified board *	850	mW
Operating temperature	T _{opr}		-20 to +85	°C
Storage temperature	T _{stg}		-55 to +150	°C

* Specified board : 57mm × 57mm × 1.6mm, glass epoxy both side board.

Caution 1) Absolute maximum ratings represent the value which cannot be exceeded for any length of time.

Caution 2) Even when the device is used within the range of absolute maximum ratings, as a result of continuous usage under high temperature, high current, high voltage, or drastic temperature change, the reliability of the IC may be degraded. Please contact us for the further details.

■ Any and all SANYO Semiconductor Co.,Ltd. products described or contained herein are, with regard to "standard application", intended for the use as general electronics equipment. The products mentioned herein shall not be intended for use for any "special application" (medical equipment whose purpose is to sustain life, aerospace instrument, nuclear control device, burning appliances, transportation machine, traffic signal system, safety equipment etc.) that shall require extremely high level of reliability and can directly threaten human lives in case of failure or malfunction of the product or may cause harm to human bodies, nor shall they grant any guarantee thereof. If you should intend to use our products for new introduction or other application different from current conditions on the usage of automotive device, communication device, office equipment, industrial equipment etc. , please consult with us about usage condition (temperature, operation time etc.) prior to the intended use. If there is no consultation or inquiry before the intended use, our customer shall be solely responsible for the use.

■ Specifications of any and all SANYO Semiconductor Co.,Ltd. products described or contained herein stipulate the performance, characteristics, and functions of the described products in the independent state, and are not guarantees of the performance, characteristics, and functions of the described products as mounted in the customer's products or equipment. To verify symptoms and states that cannot be evaluated in an independent device, the customer should always evaluate and test devices mounted in the customer's products or equipment.

SANYO Semiconductor Co., Ltd.

<http://semicon.sanyo.com/en/network>

LV8417CS

Allowable Operating Conditions at $T_a = 25^\circ\text{C}$, $\text{SGND} = \text{PGND} = 0\text{V}$

Parameter	Symbol	Conditions	Ratings	Unit
Power supply voltage (V_M pin)	V_M		2.0 to 10.5	V
Power supply voltage (V_{CC} pin)	V_{CC}		2.7 to 5.5	V
Input signal voltage	V_{IN}		0 to V_{CC}	V
Input signal frequency	f_{max}	Duty = 50%	200	kHz

Electrical Characteristics $T_a = 25^\circ\text{C}$, $V_{CC} = 3.0\text{V}$, $V_M = 6.0\text{V}$, $\text{SGND} = \text{PGND} = 0\text{V}$

Parameter	Symbol	Conditions	Remarks	Ratings			Unit	
				min	typ	max		
Standby load current drain	I_{MO}	$\text{ENA} = 0\text{V}$	1			1.0	μA	
Operating load current drain	I_{M1}	$\text{ENA} = 3.0\text{V}$, No load	3		80	120	μA	
Standby control current drain	I_{CO}	$\text{ENA} = \text{IN1} = \text{IN2} = 0\text{V}$	2			1.0	μA	
Operating current consumption 1	I_{C1}	$\text{ENA} = 3.0\text{V}$, No load	3		0.5	0.8	mA	
High-level input voltage	V_{IH}	$2.7 \leq V_{CC} \leq 5.5\text{V}$		$0.6 \times V_{CC}$		V_{CC}	V	
Low-level input voltage	V_{IL}	$2.7 \leq V_{CC} \leq 5.5\text{V}$		0		$0.2 \times V_{CC}$	V	
High-level input current ($\text{ENA}, \text{IN1}, \text{IN2}$)	I_{IH1}	$V_{IN} = 3\text{V}$			20	30	μA	
Low-level input current ($\text{ENA}, \text{IN1}, \text{IN2}$)	I_{IL1}	$V_{IN} = 0\text{V}$		-1.0			μA	
Pull-down resistance value	R_{DN}	$\text{ENA}, \text{IN1}, \text{IN2}$	4	100	200	400	k Ω	
Output ON resistance	R_{ON}	Sum of top and bottom sides ON resistance.	5		0.27	0.4	Ω	
Low-voltage detection operating voltage	V_{CS1}	V_{CC} pin voltage	6	2.1	2.3	2.5	V	
Low-voltage detection release voltage	V_{CS2}	V_{CC} pin voltage	6	2.3	2.5	2.7	V	
Thermal shutdown temperature	T_{th}	Design guarantee *	7	150	180	210	$^\circ\text{C}$	
Output block	Turn-on time	T_{PLH}	No load	8		0.10	0.15	μs
	Output response time H	T_{IOH}	No load, Design guarantee *	9		0.23	0.35	μs
	Turn-off time	T_{PHL}	No load	8		0.10	0.15	μs
	Output response time L	T_{IOL}	No load, Design guarantee *	9		0.25	0.38	μs

Remarks

- Current consumption when output at the V_M pin is off.
- Current consumption at the V_{CC} pin when in all function stop.
- Current consumption at the V_{CC} pin when $\text{ENA}=3\text{V}$ (IC starting time).
- $\text{ENA}, \text{IN1}$ and IN2 pin have an internal pull-down resistor.
- The saturation voltage of the bottom above an OUT pin is added, and the value broken by the current value is shown.
- All output transistors are turned off if a low-voltage is detected for V_{CC} .
- All output transistors are turned off if the thermal protection circuit is activated. They are turned on again as the temperature goes down.
- Rising time from 10 to 90% and falling time from 90 to 10% are specified.
- Time until it changes OUT pin voltage 10% from the time of change of input pin voltage being 50% of V_{CC} is specified.

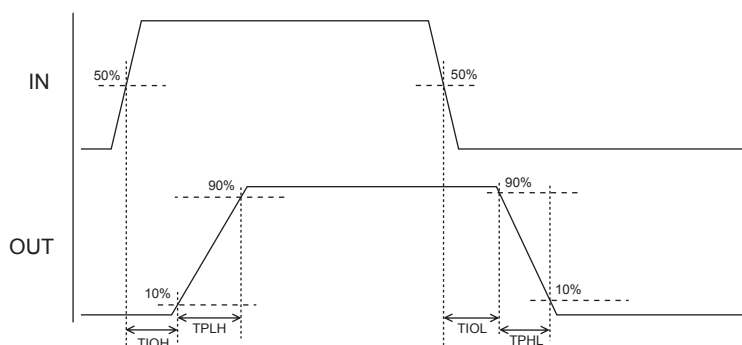

LV8417CS

Package Dimensions

unit : mm (typ)

3418

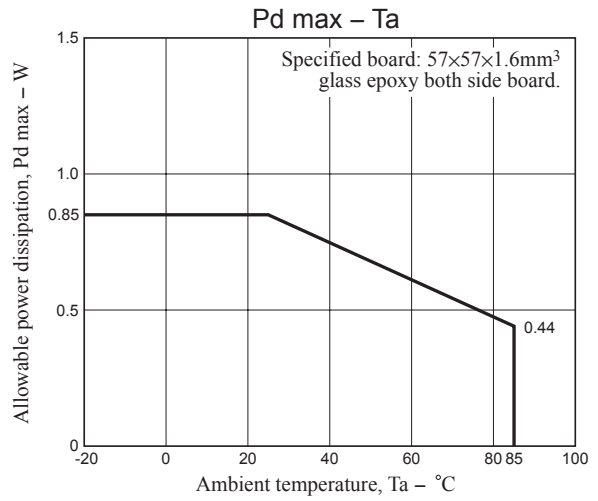
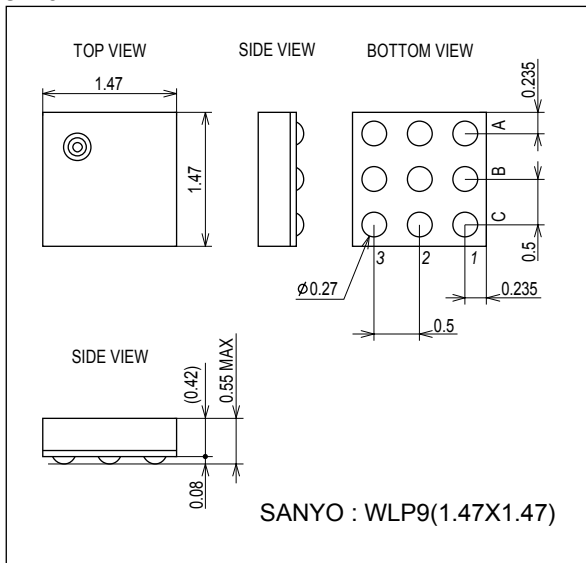

Pin Assignment

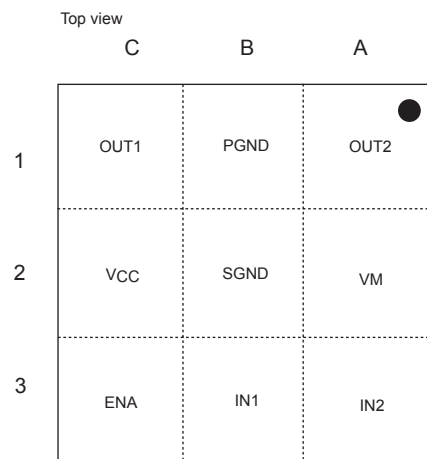
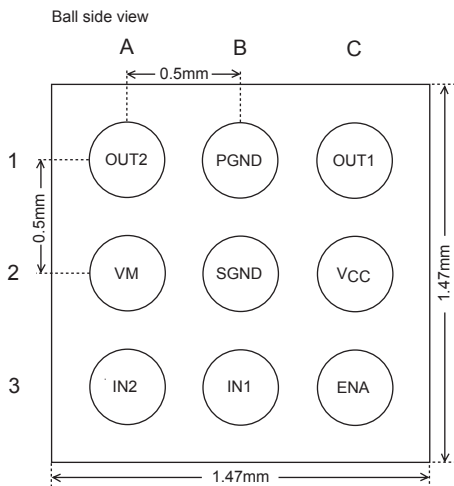

Block Diagram

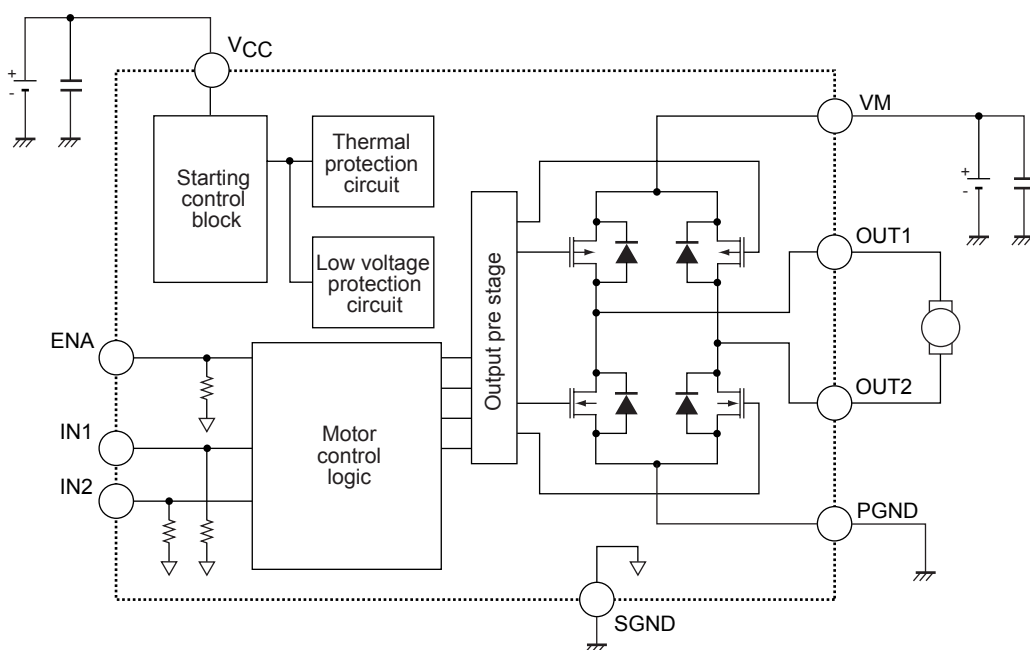

LV8417CS

Pin Functions

Pin No.	Pin name	Description	Equivalent circuit
C-3 B-3 A-3 C-2 B-2	ENA IN1 IN2 V _{CC} SGND	Logic enable pin Driver output change pin Driver output change pin Power supply for control Ground pin for control	
A-2 C-1 A-1 B-1	V _M OUT1 OUT2 PGND	Power supply for load Driver output pin Driver output pin Ground pin for load	

Truth Table

ENA	IN1	IN2	OUT1	OUT2	Mode
L	-	-	Z	Z	All function stop
H	L	L	Z	Z	Standby
	H	L	H	L	Forward
	L	H	L	H	Reverse
	H	H	L	L	Brake

- : denotes a don't care value. Z : High-impedance

- Current drain is zero in all function stop mode.
- All power transistors turn off and the motor stops driving when the IC is detected in low voltage or thermal protection mode.

Sample Application Circuit

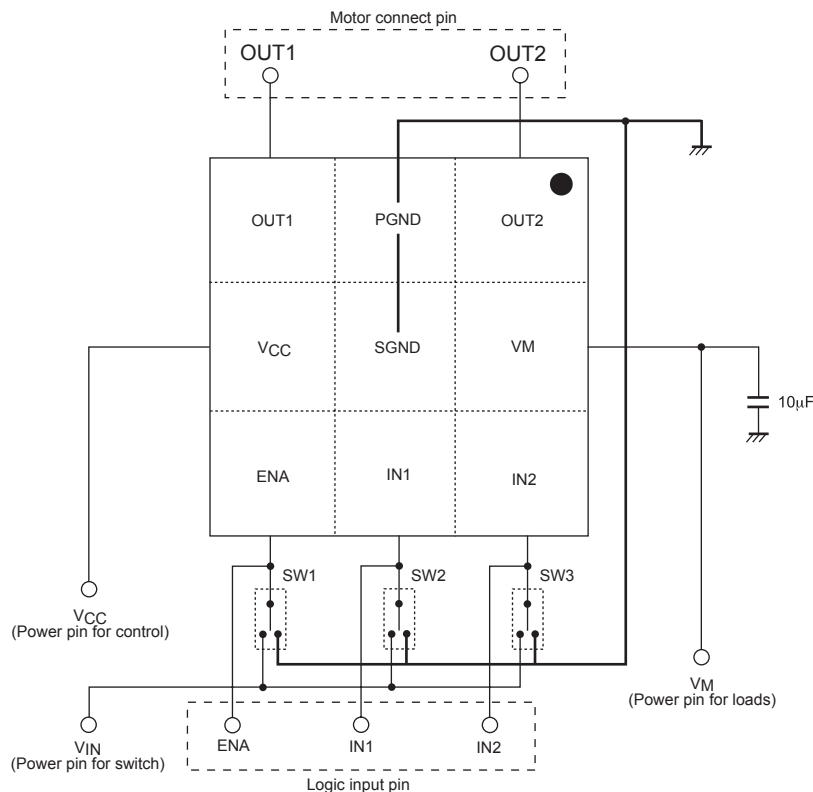

* Connect a kickback absorbing capacitor as close as possible to the IC. Characteristics deterioration of the IC or damage may result if an instantaneous voltage surge exceeding the maximum rated value is applied to the VM line due to coil kickback or other causes.

- SANYO Semiconductor Co.,Ltd. assumes no responsibility for equipment failures that result from using products at values that exceed, even momentarily, rated values (such as maximum ratings, operating condition ranges, or other parameters) listed in products specifications of any and all SANYO Semiconductor Co.,Ltd. products described or contained herein.
- SANYO Semiconductor Co.,Ltd. strives to supply high-quality high-reliability products, however, any and all semiconductor products fail or malfunction with some probability. It is possible that these probabilistic failures or malfunction could give rise to accidents or events that could endanger human lives, trouble that could give rise to smoke or fire, or accidents that could cause damage to other property. When designing equipment, adopt safety measures so that these kinds of accidents or events cannot occur. Such measures include but are not limited to protective circuits and error prevention circuits for safe design, redundant design, and structural design.
- In the event that any or all SANYO Semiconductor Co.,Ltd. products described or contained herein are controlled under any of applicable local export control laws and regulations, such products may require the export license from the authorities concerned in accordance with the above law.
- No part of this publication may be reproduced or transmitted in any form or by any means, electronic or mechanical, including photocopying and recording, or any information storage or retrieval system, or otherwise, without the prior written consent of SANYO Semiconductor Co.,Ltd.
- Any and all information described or contained herein are subject to change without notice due to product/technology improvement, etc. When designing equipment, refer to the "Delivery Specification" for the SANYO Semiconductor Co.,Ltd. product that you intend to use.
- Upon using the technical information or products described herein, neither warranty nor license shall be granted with regard to intellectual property rights or any other rights of SANYO Semiconductor Co.,Ltd. or any third party. SANYO Semiconductor Co.,Ltd. shall not be liable for any claim or suits with regard to a third party's intellectual property rights which has resulted from the use of the technical information and products mentioned above.

This catalog provides information as of December, 2011. Specifications and information herein are subject to change without notice.



Компания «ЭлектроПласт» предлагает заключение долгосрочных отношений при поставках импортных электронных компонентов на взаимовыгодных условиях!

Наши преимущества:

- Оперативные поставки широкого спектра электронных компонентов отечественного и импортного производства напрямую от производителей и с крупнейших мировых складов;
- Поставка более 17-ти миллионов наименований электронных компонентов;
- Поставка сложных, дефицитных, либо снятых с производства позиций;
- Оперативные сроки поставки под заказ (от 5 рабочих дней);
- Экспресс доставка в любую точку России;
- Техническая поддержка проекта, помощь в подборе аналогов, поставка прототипов;
- Система менеджмента качества сертифицирована по Международному стандарту ISO 9001;
- Лицензия ФСБ на осуществление работ с использованием сведений, составляющих государственную тайну;
- Поставка специализированных компонентов (Xilinx, Altera, Analog Devices, Intersil, Interpoint, Microsemi, Aeroflex, Peregrine, Syfer, Eurofarad, Texas Instrument, Miteq, Cobham, E2V, MA-COM, Hittite, Mini-Circuits, General Dynamics и др.);

Помимо этого, одним из направлений компании «ЭлектроПласт» является направление «Источники питания». Мы предлагаем Вам помощь Конструкторского отдела:

- Подбор оптимального решения, техническое обоснование при выборе компонента;
- Подбор аналогов;
- Консультации по применению компонента;
- Поставка образцов и прототипов;
- Техническая поддержка проекта;
- Защита от снятия компонента с производства.



Как с нами связаться

Телефон: 8 (812) 309 58 32 (многоканальный)

Факс: 8 (812) 320-02-42

Электронная почта: org@eplast1.ru

Адрес: 198099, г. Санкт-Петербург, ул. Калинина, дом 2, корпус 4, литера А.