

# SSL - Discrete Wire IDC Contact & Cap

## Series 9176-500

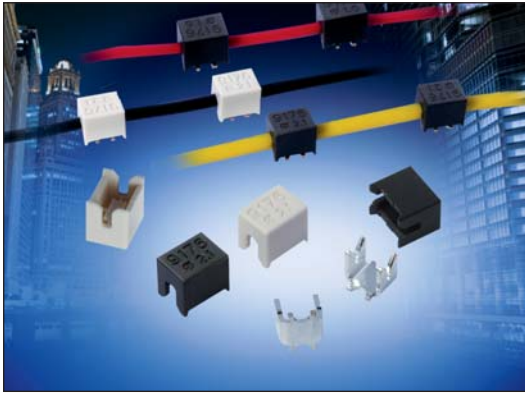

The 917X series of surface mount Insulation Displacement Connectors (IDC) were developed to meet the harsh automotive and industrial market applications for connecting individual wires directly to a PCB ranging from 14 AWG to 28 AWG. This industry proven contact system has been tested to automotive levels of shock, vibration, and temperature cycling to prove their reliability and robustness. This new single contact was developed as a standalone component to enhance the application uses with the IDC technology. The simplicity of inserting a wire into an SMT contact with a small tool or optional retention / termination cap allows a wide range of devices to be connected to the PCB without soldering. In SSL applications specifically, these contacts are used to bring power and signal onto the PCB or are used to daisy chain multiple boards together in a long string. While the IDC contact provides a gas-tight connection to conductor of the wire, the optional cap provides a positive strain relief even in the harshest conditions. In case of repair, the wires can be removed and replace up to three times.

The single 9176 series contact and cap accepts 18 AWG to 24 AWG wires with an insulation diameter ranging from 1.1mm to 2.1mm. These dual beam contacts support a 10 amp current rating with a large SMT solder base to provide maximum stability on the PCB. The optional locking strain relief cap acts as the termination tool for severe vibration applications.

### APPLICATIONS

- Connecting discrete wire components directly to the PCB
- Bringing power and signals onto a PCB
- Daisy chaining PCB's together to create a continuous string of boards
- Application notes: refer to 201-01-124

### FEATURES AND BENEFITS

- IDC contact is supplied in T&R pockets for standard SMT placement
- IDC contact provides a gas-tight connection to the PCB for long term reliability
- Optional termination cap provides additional strain relief for severe environments
- Tested to automotive levels on shock, vibration and temperature cycling for reliability
- Reduced total applied cost versus solder or crimp processes
- Individual contacts can be located anywhere on the PCB based on specific application

### ELECTRICAL

- Current Rating: 10 Amps/Contact
- Voltage Rating: Dependant on component proximity

### ENVIRONMENTAL

- Operating Temperature: -40°C to +125°C

### MECHANICAL

- Insulator Material: Nylon 46: UL94V0
- Contact Material: Phosphor Bronze
- Plating: Tin over Nickel
- Durability: 3 Cycles

### HOW TO ORDER – CONTACT OPTIONS

<b>70</b>	<b>9176</b>	<b>001</b>	<b>5XX</b>	<b>006</b>																
Prefix	Series	Number of Ways	Wire Gauge Size	Plating Option																
70 = Contact				06 = Pure Tin all over																
		<table border="1"> <thead> <tr> <th>Code</th> <th>No of Ways</th> <th>Details</th> </tr> </thead> <tbody> <tr> <td>001</td> <td>1</td> <td>Page 58</td> </tr> </tbody> </table>	Code	No of Ways	Details	001	1	Page 58	<table border="1"> <thead> <tr> <th>Code</th> <th>Accepted Wire Gauge</th> </tr> </thead> <tbody> <tr> <td>501</td> <td>18 Gauge Stranded</td> </tr> <tr> <td>511</td> <td>20 Gauge Stranded</td> </tr> <tr> <td>522</td> <td>22 Gauge Stranded</td> </tr> <tr> <td>532</td> <td>24 Gauge Stranded</td> </tr> </tbody> </table>	Code	Accepted Wire Gauge	501	18 Gauge Stranded	511	20 Gauge Stranded	522	22 Gauge Stranded	532	24 Gauge Stranded	
Code	No of Ways	Details																		
001	1	Page 58																		
Code	Accepted Wire Gauge																			
501	18 Gauge Stranded																			
511	20 Gauge Stranded																			
522	22 Gauge Stranded																			
532	24 Gauge Stranded																			

### HOW TO ORDER – CAP OPTIONS

<b>60</b>	<b>9176</b>	<b>001</b>	<b>5XX</b>	<b>X00</b>																					
Prefix	Series	Number of Ways	Wire Gauge Size	Insulator Color																					
60 = Cap																									
		<table border="1"> <thead> <tr> <th>Code</th> <th>No of Ways</th> <th>Details</th> </tr> </thead> <tbody> <tr> <td>001</td> <td>1</td> <td>Page 60</td> </tr> </tbody> </table>	Code	No of Ways	Details	001	1	Page 60	<table border="1"> <thead> <tr> <th>Code</th> <th>Wire Insulation (AWG)</th> </tr> </thead> <tbody> <tr> <td>516</td> <td>1.1-1.6 (22-24)</td> </tr> <tr> <td>521</td> <td>1.6-2.1 (18-20)</td> </tr> </tbody> </table>	Code	Wire Insulation (AWG)	516	1.1-1.6 (22-24)	521	1.6-2.1 (18-20)	<table border="1"> <thead> <tr> <th>Code</th> <th>Color</th> <th>Application</th> </tr> </thead> <tbody> <tr> <td>0</td> <td>Black</td> <td>Industrial</td> </tr> <tr> <td>1</td> <td>White</td> <td>Lighting</td> </tr> </tbody> </table>	Code	Color	Application	0	Black	Industrial	1	White	Lighting
Code	No of Ways	Details																							
001	1	Page 60																							
Code	Wire Insulation (AWG)																								
516	1.1-1.6 (22-24)																								
521	1.6-2.1 (18-20)																								
Code	Color	Application																							
0	Black	Industrial																							
1	White	Lighting																							

# SSL - Discrete Wire IDC Contact & Cap

Series 9176-500

## CONTACT DETAILS

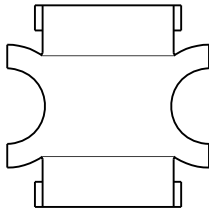
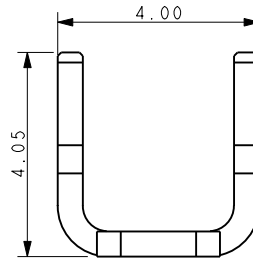
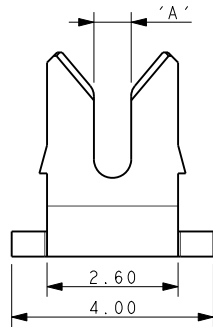

AREA AVAILABLE FOR PICK & PLACE 2.00mm SQUARE

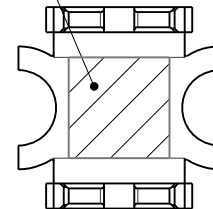

Code	Accepted Wire Gauge	A
501	18 Gauge Stranded	0.72
511	20 Gauge Stranded	0.60
522	22 Gauge Stranded	0.47
532	24 Gauge Stranded	0.37

### NOTES:

- CONNECTOR FOR IDC WIRE TO BOARD CONNECTION.
- CONTACT MATERIAL: PHOSPHORE BRONZE.
- CONTACT PLATING: PURE TIN.
- CONNECTOR DESIGNED TO ACCEPT BETWEEN 18 AND 24 GAUGE STRANDED WIRE. SEE TABLE.
- ALL DIMENSIONS FOR REFERENCE UNLESS OTHERWISE STATED.
- FOR FULL PRODUCT SPECIFICATION REFER TO ELCO SPEC 201-01-106 AND APPLICATION NOTES 201-01-124.
- SMT PCB LAYOUT, REFER TO PAGE 58.
- PACKING IN TAPE AND REEL, QUANTITY 1000 PER REEL.
- WHEN REQUIRED, MATCHING CAP DETAILS ON DRAWING 60-9176-001-5XX-X00S.
- ASSEMBLY TOOLING ON PAGE 59 (WITH CAP AND WITHOUT CAP).

## PACKING DETAILS

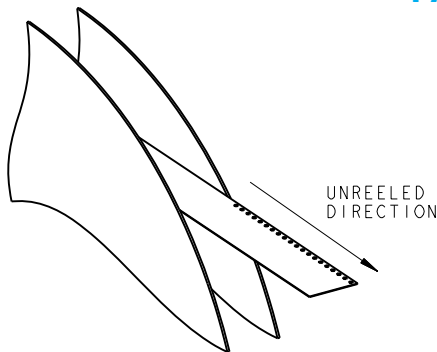

REEL QTY	1000
LEADER	480MM
TRAILER	120MM

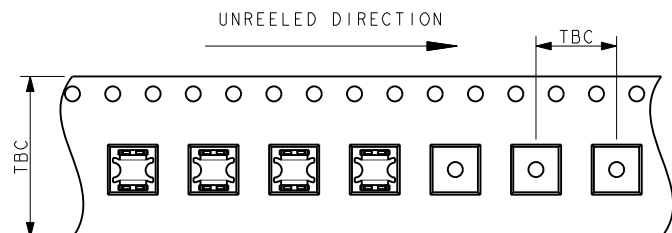

# SSL - Discrete Wire IDC Contact & Cap **AVX**

Series 9176-500

## 18-24 AWG IDC WIRE TO BOARD CONNECTOR SINGLE CONTACT

### SMT PCB LAYOUT

PURE TIN PADS

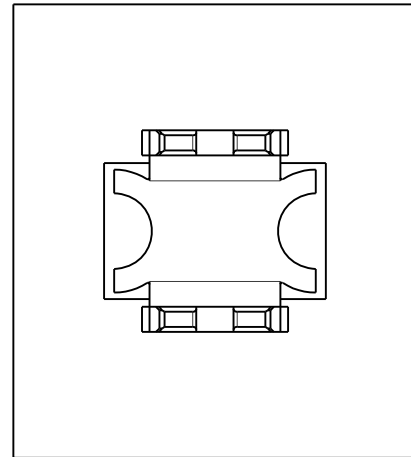
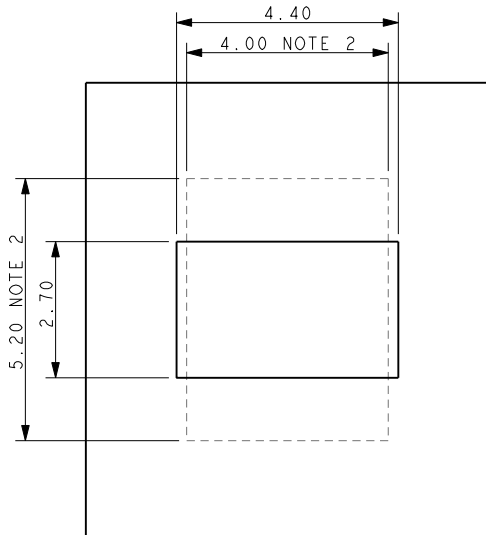

ORIENTATION OF CONTACT ON PAD

### ASSEMBLED/INSTALLED PRODUCTS

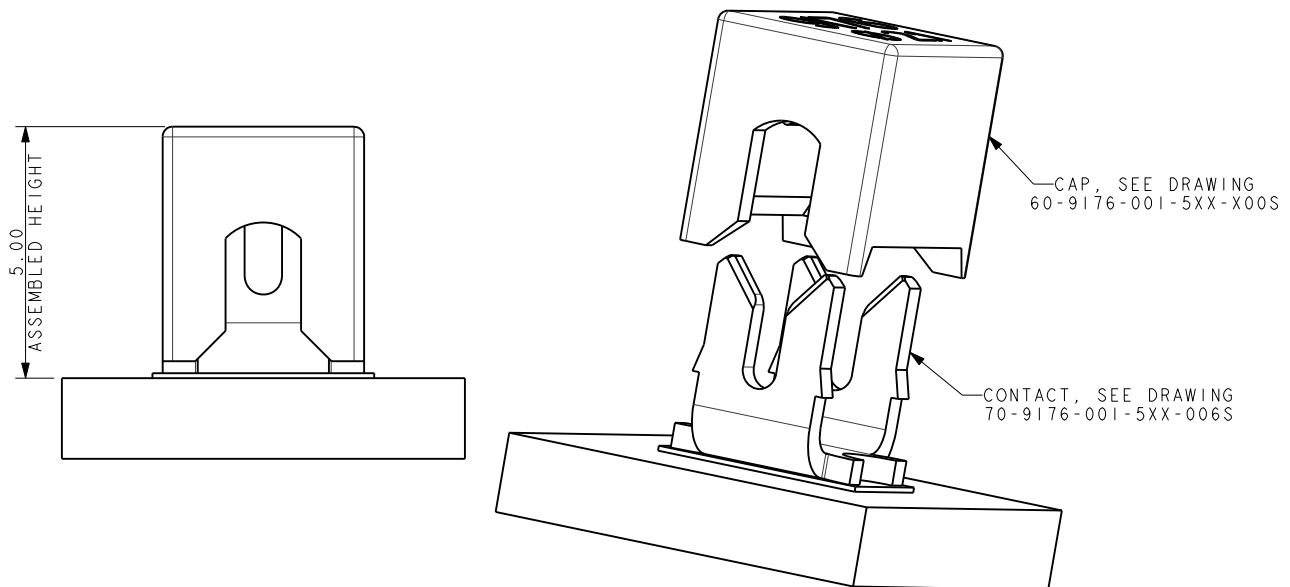

#### NOTES:

1. CONNECTOR CAN BE USED WITH CONTACT ONLY OR WITH OPTIONAL CAP.
2. OUTLINE OF CAP WHEN USED.
3. FOR FULL PRODUCT SPECIFICATION REFER TO ELCO SPEC 201-01-106 AND 201-01-124.
4. DIMENSIONS SHOWN ARE REFERENCED DIMENSIONS.
5. ASSEMBLY TOOLING ON PAGE 59 (WITH CAP AND WITHOUT CAP).

# SSL - Discrete Wire IDC Contact & Cap

Series 9176-500

## ASSEMBLY TOOLING – CAP USED

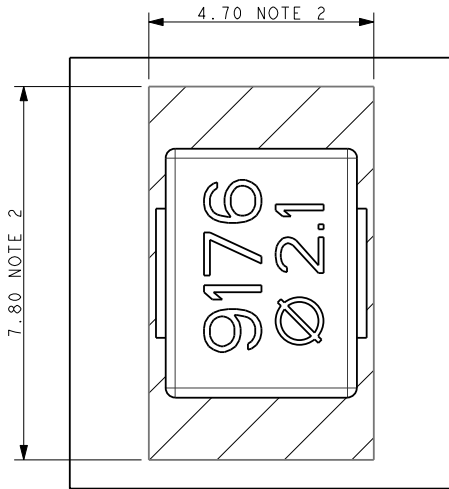

### CAP APPLICATION TOOL

06-9176-7018-01-000

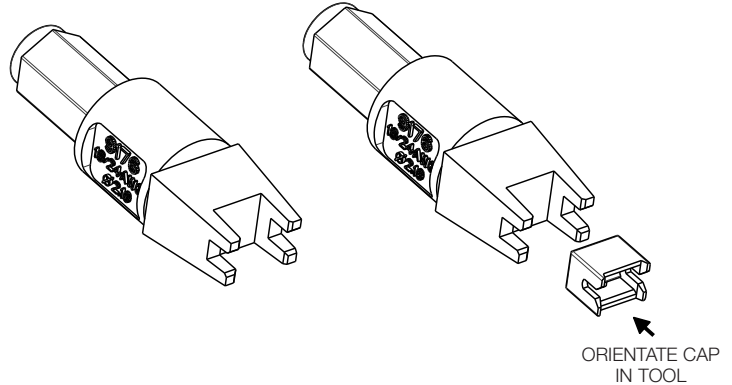

### UNIVERSAL HANDLE

06 7000 7730 01 000

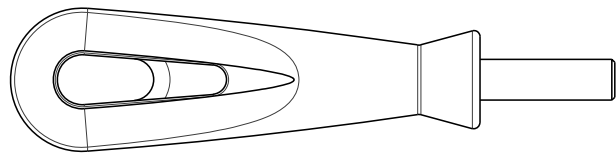

#### NOTES:

1. ASSEMBLY TOOLING FOR CAP.
2. AREA OF PCB TO BE KEPT CLEAR OF COMPONENTS, TACKS PERMISSIBLE.
3. WIRE AND CAP INSERTED IN ONE OPERATION.
4. REFER TO APPLICATION NOTE 201-01-124 FOR FURTHER INFORMATION.
5. REFER BELOW WHEN CONTACT USED WITHOUT CAP.

## ASSEMBLY TOOLING – CAP NOT USED WIRE ONTO CONTACT

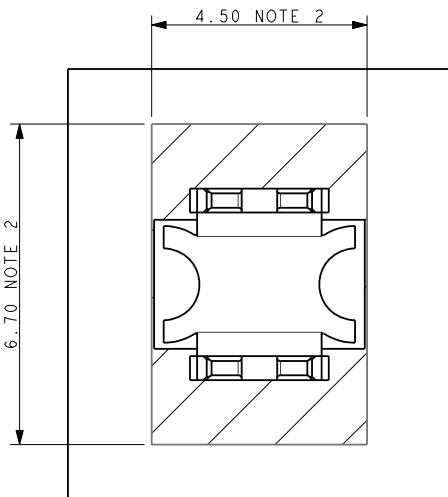

### 2.1 WIRE (18-20 AWG)

06-9176-7019-01-000  
06-9176-7020-01-000

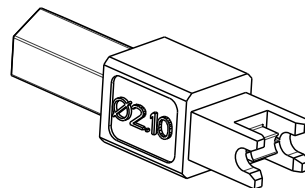

### 1.6 WIRE (22-24 AWG)

06-9176-7019-02-000  
06-9176-7020-02-000

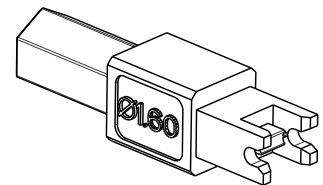

### UNIVERSAL HANDLE

06 7000 7730 01 000

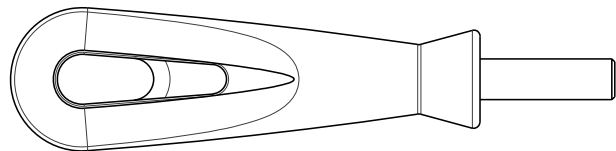

#### NOTES:

1. ASSEMBLY TOOLING FOR CONTACT ONLY, NO CAP USED.
2. MINIMUM AREA OF PCB TO BE KEPT CLEAR OF COMPONENTS, TRACK PERMISSIBLE.
3. REFER TO TABLE FOR CORRECT TOOL/WIRE COMBINATION.
4. REFER TO APPLICATION NOTE 201-01-124 FOR FURTHER INFORMATION.

Wire Gauge	Wire Insulation $\phi$	Metal Tool High Volume	Plastic Tool Small to Medium Volume	Handle
22-24 AWG	1.10 to 1.60	06-9176-7019-02-000	06-9176-7020-02-000	06-7000-7730-01-000
18-20 AWG	1.60 to 2.10	06-9176-7019-01-000	06-9176-7020-01-000	06-7000-7730-01-000

# SSL - Discrete Wire IDC Contact & Cap

Series 9176-500

## CAP DETAILS

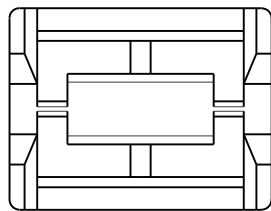
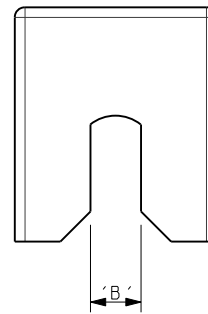
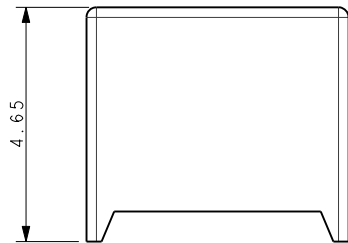
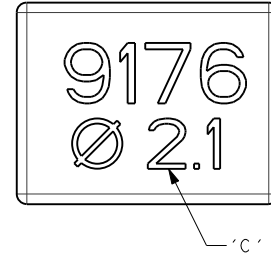
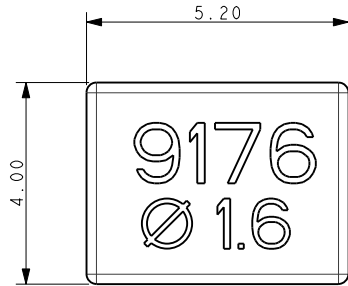

Code	Insulator Diameter (AWG)	B	Text C
516	1.1 to 1.6 (22-24)	1.00	Ø 1.6
521	1.6 to 2.1 (18-20)	1.50	Ø 2.1

### NOTES:

1. CAP FOR IDC WIRE TO BOARD CONNECTION.
2. CAP MATERIAL: GLASS FILLED NYLON 46, COLOR SEE PAGE 56.
3. CAPS DESIGNED TO ACCOMMODATE WIRE INSULATION DIAMETERS 1.1MM TO 2.1MM.
4. ALL DIMENSIONS FOR REFERENCE UNLESS OTHERWISE STATED.
5. FOR FULL PRODUCT SPECIFICATION REFER TO ELCO SPEC 201-01-106, APPLICATION NOTES 201-01-124.
6. PACKING IN BAGS, QUANTITY 1000 PER BAG.
7. FOR INSTALATION DETAILS REFER TO DRAWING 70-9176-001-XX-006S.



Компания «ЭлектроПласт» предлагает заключение долгосрочных отношений при поставках импортных электронных компонентов на взаимовыгодных условиях!

Наши преимущества:

- Оперативные поставки широкого спектра электронных компонентов отечественного и импортного производства напрямую от производителей и с крупнейших мировых складов;
- Поставка более 17-ти миллионов наименований электронных компонентов;
- Поставка сложных, дефицитных, либо снятых с производства позиций;
- Оперативные сроки поставки под заказ (от 5 рабочих дней);
- Экспресс доставка в любую точку России;
- Техническая поддержка проекта, помощь в подборе аналогов, поставка прототипов;
- Система менеджмента качества сертифицирована по Международному стандарту ISO 9001;
- Лицензия ФСБ на осуществление работ с использованием сведений, составляющих государственную тайну;
- Поставка специализированных компонентов (Xilinx, Altera, Analog Devices, Intersil, Interpoint, Microsemi, Aeroflex, Peregrine, Syfer, Eurofarad, Texas Instrument, Miteq, Cobham, E2V, MA-COM, Hittite, Mini-Circuits, General Dynamics и др.);

Помимо этого, одним из направлений компании «ЭлектроПласт» является направление «Источники питания». Мы предлагаем Вам помощь Конструкторского отдела:

- Подбор оптимального решения, техническое обоснование при выборе компонента;
- Подбор аналогов;
- Консультации по применению компонента;
- Поставка образцов и прототипов;
- Техническая поддержка проекта;
- Защита от снятия компонента с производства.



#### Как с нами связаться

**Телефон:** 8 (812) 309 58 32 (многоканальный)

**Факс:** 8 (812) 320-02-42

**Электронная почта:** [org@eplast1.ru](mailto:org@eplast1.ru)

**Адрес:** 198099, г. Санкт-Петербург, ул. Калинина, дом 2, корпус 4, литера А.