

### FEATURES

- Compact and battery operated
- Comprehensive I/O on a single board
- An expandable, scalable engine
- Graphics galore including LCD to XGA and touchscreen interface
- Operating System options: from Windows CE to Linux
- Power and power management

**The BitsyXb delivers low power in a small form factor and at a low cost with proven success in a wide range of vertical markets.** The BitsyXb, based on the Marvell PXA270, offers a rich set of graphics, communications, and I/O capabilities. The BitsyXb can be used as a stand-alone single board computer or can be integrated with a standard or custom adapter board for further feature expansions, including Power over Ethernet. The Bitsy Xb is designed as low-cost, application-ready platform that can reduce the product-to-market cycle from years to several months. To date, the Bitsy family of embedded computers from Eurotech Inc. has been quickly and readily “reconfigured” to satisfy dozens of application requirements.

Eurotech’s quick-turn capabilities are based on a world class engineering house with expertise in quickly and successfully reconfiguring systems using a deep reserve of hardware and software device technologies.

PROCESSOR	32-bit Marvell PXA270 RISC processor at 520 MHz
GRAPHICS/VIDEO	Video interface up to SVGA (800x600) color LCD interface (driven by the PXA270) Backlight connector with PWM + ON/OFF controlled by software 4 or 5 wire resistive touchscreen
AUDIO	AC'97, 16 bit stereo Codec
MEMORY	Program/Frame Buffer SDRAM to 128 Mbytes Flash Memory to 64 (Synchronous) Mbytes (32 asynchronous) One PCMCIA (Type II, also available for devices such as Ethernet, 802.11, etc.
OPERATING ENVIRONMENTS	Windows CE 6.0 Linux Others (contact factory for all options)
COMPREHENSIVE COMMUNICATIONS	One USB host port, one USB function port (personality board required for connectors) Three Serial Ports 10 digital I/Os SPI port I2C bus with I2C master controller ADSmartIO, 9 configurable input/outputs Support for PS2 keyboard (with personality board) - optional Support for external interrupt inputs Expansion slot (header) with 16 address and 11 data lines
PERIPHERALS	Real Time Clock Software controlled LED status indicator
DIMENSIONS / POWER REQUIREMENTS	3" x 5" 5V or 6 - 16V input <1W in operation Complete and partitioned on-board power supply
ADAPTER BOARD EXPANDABILITY	Compact Flash slot (Type II connector) Ethernet 10/100bT Power over Ethernet

\*Specifications and features subject to change without notice  
See our website for latest updates and more information  
[www.eurotech-inc.com](http://www.eurotech-inc.com)

### About Us

Eurotech delivers embedded computer systems for high capability and low power applications, networking and wearable computing solutions, and application framework middleware for multimedia, industrial, transportation, medical, and wireless applications. Eurotech platforms allow OEM and enterprise customers to focus on their core revenue-generating products and services and get to market quickly.

BitsyXb is a trademark of Eurotech Inc.  
Other trademarks are property of their respective holders.

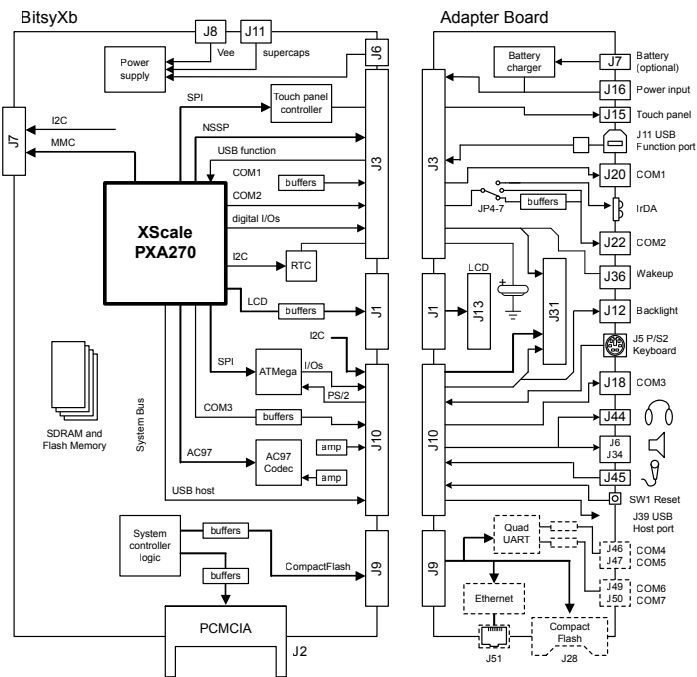

CMM4467E Aug2008v1.0



Компания «ЭлектроПласт» предлагает заключение долгосрочных отношений при поставках импортных электронных компонентов на взаимовыгодных условиях!

Наши преимущества:

- Оперативные поставки широкого спектра электронных компонентов отечественного и импортного производства напрямую от производителей и с крупнейших мировых складов;
- Поставка более 17-ти миллионов наименований электронных компонентов;
- Поставка сложных, дефицитных, либо снятых с производства позиций;
- Оперативные сроки поставки под заказ (от 5 рабочих дней);
- Экспресс доставка в любую точку России;
- Техническая поддержка проекта, помощь в подборе аналогов, поставка прототипов;
- Система менеджмента качества сертифицирована по Международному стандарту ISO 9001;
- Лицензия ФСБ на осуществление работ с использованием сведений, составляющих государственную тайну;
- Поставка специализированных компонентов (Xilinx, Altera, Analog Devices, Intersil, Interpoint, Microsemi, Aeroflex, Peregrine, Syfer, Eurofarad, Texas Instrument, Miteq, Cobham, E2V, MA-COM, Hittite, Mini-Circuits, General Dynamics и др.);

Помимо этого, одним из направлений компании «ЭлектроПласт» является направление «Источники питания». Мы предлагаем Вам помощь Конструкторского отдела:

- Подбор оптимального решения, техническое обоснование при выборе компонента;
- Подбор аналогов;
- Консультации по применению компонента;
- Поставка образцов и прототипов;
- Техническая поддержка проекта;
- Защита от снятия компонента с производства.



#### Как с нами связаться

**Телефон:** 8 (812) 309 58 32 (многоканальный)

**Факс:** 8 (812) 320-02-42

**Электронная почта:** [org@eplast1.ru](mailto:org@eplast1.ru)

**Адрес:** 198099, г. Санкт-Петербург, ул. Калинина, дом 2, корпус 4, литера А.