

SST Compliant Hardware Monitor with Three Temperature Channels and Three Voltage Channels

PRODUCT FEATURES

Data Brief

General Description

The EMC1133 is a one-wire sensor that is capable of monitoring up to three voltages and three temperature zones for an Intel PC platform containing an SST host. The three temperature zones consist of an internal temperature diode and two externally connected temperature diodes. In cooperation with a host device, thermal management and fan control can be performed. Communication takes place over a one-wire SST based interface. The internal 11-bit delta-sigma ADC architecture provides superb linearity, high accuracy, and excellent noise immunity.

Applications

- Desktop PCs, Servers and Workstations

Features

- Single Wire Interface (SST based)
 - SST 1.0 compliant
 - Fixed Address, Discoverable Device
 - Three programmable addresses
 - Supports FCS Abort functionality not available in SST 0.9 compliant devices

- Resistance Error Correction
- Ideality Configuration
- Beta Compensation
- Two External Temperature Monitors
 - 0.125°C resolution
 - ±1°C Accuracy (50°C to 70°C)
 - Diode Fault Reporting
 - Second External Diode configured to read a discrete diode.
- Internal Temperature Monitor
 - Range -40°C to +125°C
 - 0.125°C resolution
 - ±2°C Accuracy (40°C to 70°C)
- Voltage Monitor:
 - 3.3V, 2.5V, VCCP inputs
 - 2% Total Unadjusted Error
 - 11-bit resolution
- Supply
 - 3.0V to 3.6V

Simplified Block Diagram

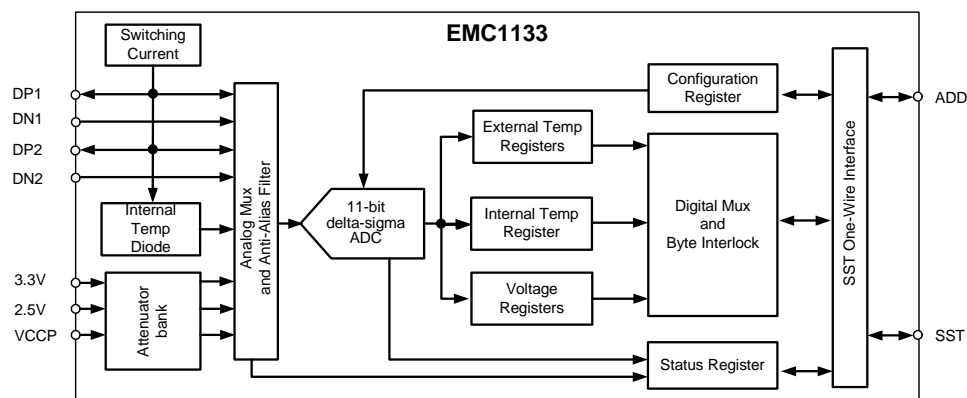

ORDER NUMBER:

PART NUMBER	FEATURES	PACKAGE
EMC1133-AIZL-TR	External Diode 1 configured to monitor 65nm CPU External diode 2 configured to monitor 2N3904	10 pin MSOP Lead-Free, ROHS Compliant



80 ARKAY DRIVE, HAUPPAUGE, NY 11788 (631) 435-6000, FAX (631) 273-3123

Copyright © 2007 SMSC or its subsidiaries. All rights reserved.

Circuit diagrams and other information relating to SMSC products are included as a means of illustrating typical applications. Consequently, complete information sufficient for construction purposes is not necessarily given. Although the information has been checked and is believed to be accurate, no responsibility is assumed for inaccuracies. SMSC reserves the right to make changes to specifications and product descriptions at any time without notice. Contact your local SMSC sales office to obtain the latest specifications before placing your product order. The provision of this information does not convey to the purchaser of the described semiconductor devices any licenses under any patent rights or other intellectual property rights of SMSC or others. All sales are expressly conditional on your agreement to the terms and conditions of the most recently dated version of SMSC's standard Terms of Sale Agreement dated before the date of your order (the "Terms of Sale Agreement"). The product may contain design defects or errors known as anomalies which may cause the product's functions to deviate from published specifications. Anomaly sheets are available upon request. SMSC products are not designed, intended, authorized or warranted for use in any life support or other application where product failure could cause or contribute to personal injury or severe property damage. Any and all such uses without prior written approval of an Officer of SMSC and further testing and/or modification will be fully at the risk of the customer. Copies of this document or other SMSC literature, as well as the Terms of Sale Agreement, may be obtained by visiting SMSC's website at <http://www.smisc.com>. SMSC is a registered trademark of Standard Microsystems Corporation ("SMSC"). Product names and company names are the trademarks of their respective holders.

SMSC DISCLAIMS AND EXCLUDES ANY AND ALL WARRANTIES, INCLUDING WITHOUT LIMITATION ANY AND ALL IMPLIED WARRANTIES OF MERCHANTABILITY, FITNESS FOR A PARTICULAR PURPOSE, TITLE, AND AGAINST INFRINGEMENT AND THE LIKE, AND ANY AND ALL WARRANTIES ARISING FROM ANY COURSE OF DEALING OR USAGE OF TRADE. IN NO EVENT SHALL SMSC BE LIABLE FOR ANY DIRECT, INCIDENTAL, INDIRECT, SPECIAL, PUNITIVE, OR CONSEQUENTIAL DAMAGES; OR FOR LOST DATA, PROFITS, SAVINGS OR REVENUES OF ANY KIND; REGARDLESS OF THE FORM OF ACTION, WHETHER BASED ON CONTRACT; TORT; NEGLIGENCE OF SMSC OR OTHERS; STRICT LIABILITY; BREACH OF WARRANTY; OR OTHERWISE; WHETHER OR NOT ANY REMEDY OF BUYER IS HELD TO HAVE FAILED OF ITS ESSENTIAL PURPOSE, AND WHETHER OR NOT SMSC HAS BEEN ADVISED OF THE POSSIBILITY OF SUCH DAMAGES.

Package Outline

Revision 2.58 (08-01-07)

PRODUCT PREVIEW 3

SMSC EMC1133

SST Compliant Hardware Monitor with Three Temperature Channels and Three Voltage Channels

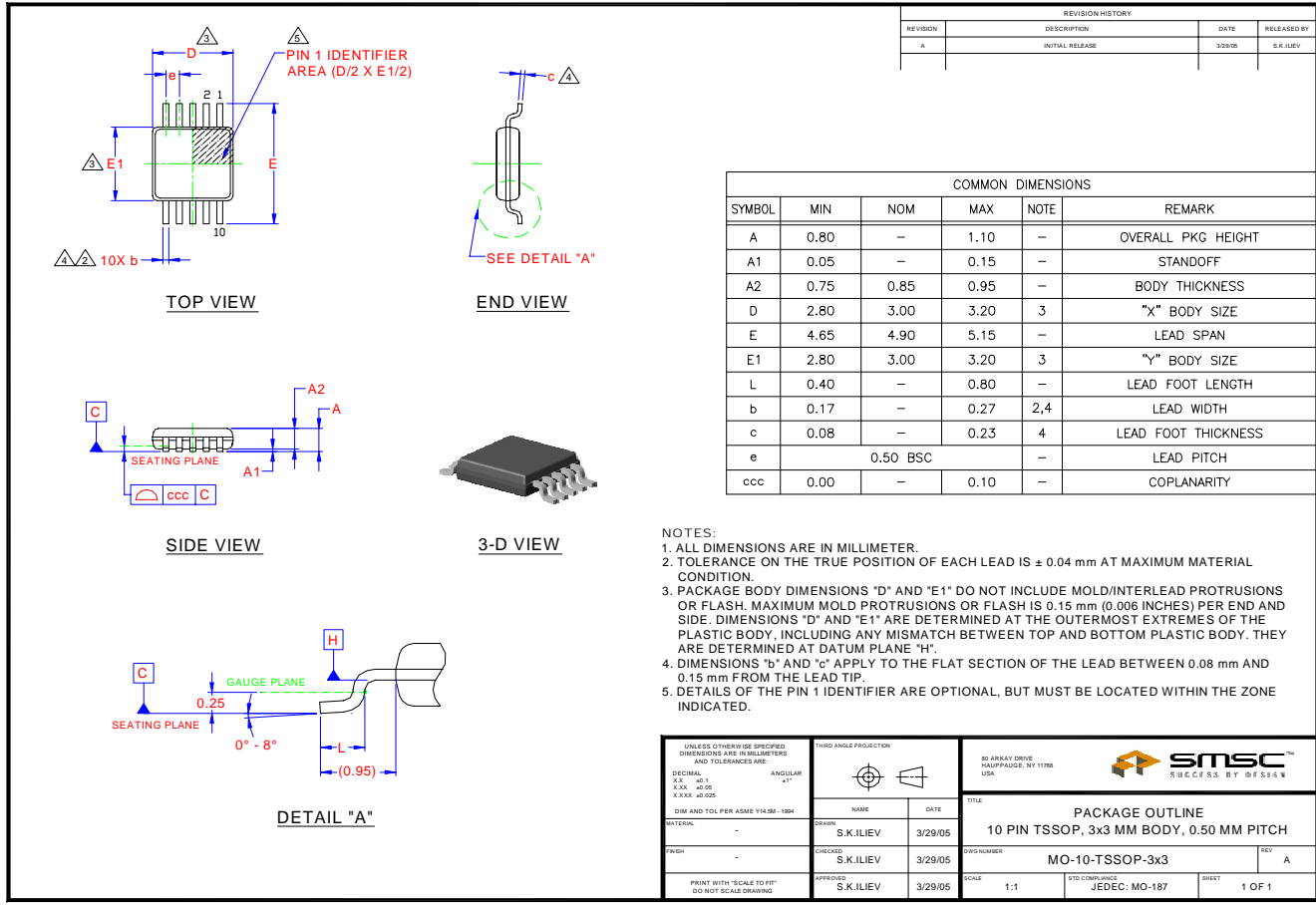

Figure 1 EMC1133 10-Pin MSOP Package Drawing



Компания «ЭлектроПласт» предлагает заключение долгосрочных отношений при поставках импортных электронных компонентов на взаимовыгодных условиях!

Наши преимущества:

- Оперативные поставки широкого спектра электронных компонентов отечественного и импортного производства напрямую от производителей и с крупнейших мировых складов;
- Поставка более 17-ти миллионов наименований электронных компонентов;
- Поставка сложных, дефицитных, либо снятых с производства позиций;
- Оперативные сроки поставки под заказ (от 5 рабочих дней);
- Экспресс доставка в любую точку России;
- Техническая поддержка проекта, помощь в подборе аналогов, поставка прототипов;
- Система менеджмента качества сертифицирована по Международному стандарту ISO 9001;
- Лицензия ФСБ на осуществление работ с использованием сведений, составляющих государственную тайну;
- Поставка специализированных компонентов (Xilinx, Altera, Analog Devices, Intersil, Interpoint, Microsemi, Aeroflex, Peregrine, Syfer, Eurofarad, Texas Instrument, Miteq, Cobham, E2V, MA-COM, Hittite, Mini-Circuits, General Dynamics и др.);

Помимо этого, одним из направлений компании «ЭлектроПласт» является направление «Источники питания». Мы предлагаем Вам помощь Конструкторского отдела:

- Подбор оптимального решения, техническое обоснование при выборе компонента;
- Подбор аналогов;
- Консультации по применению компонента;
- Поставка образцов и прототипов;
- Техническая поддержка проекта;
- Защита от снятия компонента с производства.



Как с нами связаться

Телефон: 8 (812) 309 58 32 (многоканальный)

Факс: 8 (812) 320-02-42

Электронная почта: org@eplast1.ru

Адрес: 198099, г. Санкт-Петербург, ул. Калинина, дом 2, корпус 4, литера А.