

# 24V DRIVE, FTP-60A SERIES

## ULTRA HIGH SPEED (250mm/s)

### 3" TYPE MECHANISM (with cutter option)

---

## FTP-63AMCL001/011/401/411-R

#### ■ OVERVIEW

The FTP-60AMCL Series thermal printer (driven by 24VDC) provides ultra-high speed printing (250mm/s) for 3-inch wide paper.

This series is suitable for a variety of applications, such as ATM, kiosk terminals, ticket machines, label printers, banking machines, measuring devices, medical equipment, etc.

#### ■ HIGHLIGHTS

- **Ultra high speed printing**  
It can print at 250 mm/s (2000 dotlines/s) maximum by using Fujitsu Components' unique head drive control.
- **2-D Barcode printing**  
QR, Maxi, PDF417
- **ELM (Easy Loading Mechanism) with replaceable thermal head**  
Fujitsu Components' unique platen release mechanism allows easy paper loading and easy head maintenance. 150km life minimum.
- **Auto Cutter**  
Printer with auto cutter (full cut/ partial cut) is available. It can be mounted in front of the mechanism. 1 million cuts minimum.
- **Heavy duty diecast frame**  
By application of heavy duty diecast frame, continuous printing by function of heat-sink, high ESD with stand by function of earth frame and shock/vibration with stand by function of solid frame are valid.
- **Compact size**  
Depth: 54mm (with cutter), width: 118.4mm, height: 30mm.
- **Wide temperature range**  
-20°C to +70°C.
- **RoHS compliant**



FTP-63AMCL011



FTP-63AMCL411

# FTP-63AMCL001/011/401/411

## ■ PART NUMBERS

Name		Part Number	
Printer mechanism	with FFC connector*1	Changeable head	FTP-63AMCL001
	with header connector		FTP-63AMCL011
Mechanism with cutter	with FFC connector*1	Guillotine	FTP-63AMCL401
	with header connector		FTP-63AMCL411
Interface board		USB (V 2.0)	FTP-62ADSL001
		Serial (RS232C)	FTP-62ADSL011
Interface cable (board to mechanism)		Serial	FTP-629Y302
		USB	FTP-629Y301
Power cables		Head	FTP-62AY001
		Platen / cutter motor	FTP-62AY003
		Power supply	FTP-62AY601

\*1: Requires Flat Flexible Cable (FFC)

## ■ GENERAL SPECIFICATIONS

Item		Specifications	
Part number		FTP-63AMCL001/011	FTP-63AMCL401/411
Printing method		Thermal sensitive line dot method	
Dot structure		640 dots/line	
Dot pitch (horizontal)		0.125mm (8dots/mm) - Dot density	
Dot pitch (vertical)		0.125mm x 0.16mm - Line feed pitch	
Effective printing area		80 mm maximum	
Number of columns		ANK 53 columns/line (12 x 24 dot font)	
Paper width		80-85mm +0/-1	
Paper thickness		60-150µm	
Cutting type		-	Guillotine (full or partial cut)
Printing speed	FTP-62ADSL series	200mm/sec. (1600 dot lines/sec.) line mode 250mm/sec. (2000 dot lines/sec.) page mode	
Interface types		FTP-62ADSL series	
Character types	Alphanumeric, Kana: International: JIS Kanji (Kanji CG loaded board): OCRI OCRII OCRIII Extended numeric	159 types 195 types about 6,800 types  103 types 23 types 103 types 11 types	
Character, dimensions (WxH), number of columns	8x16 dots, 80 columns: ANK 12x24 dots, 53 columns: ANK 16x16 dots, 40 columns: ANK 24x24 dots, 26 columns: ANK	24x40 dots, 26 columns, OCRI 24x48 dots, 26 columns, OCRIII 36x60 dots, 17 columns, OCRIV 24x48 dots, 26 columns, extended numeric	
Interface standard		RS232C /USB	

# FTP-63AMCL001/011/401/411

Item		Specifications	
Part number		FTP-63AMCL001/011	FTP-63AMCL401/411
Power supply	For head	24 VDC $\pm$ 5%, 5.7A (11.2A) (24V, 25% printing ratio)	
	For printer motor	24 VDC $\pm$ 5% 1.2A maximum	
	For cutter motor	---	24 VDC $\pm$ 5% 1.2A maximum
	For logic	3.3 to 5 VDC $\pm$ 5% 0.2A maximum	
Dimension W x D x H	Printer mechanism	112 x 50 x 30 /38.2mm	-
	Printer mechanism with cutter	-	119.1 x 54 x 30 /38.2mm
	Interface board (high speed)	96 x 71 x 21.2mm	
Weight	Printer mechanism	Approximately 180/185g	-
	Printer mechanism with cutter	-	Approximately 335/340g
	Interface board (high speed)	Approximately 50g	
Life	Head	Pulse durability: 150 million pulse/dot (using Fujitsu's standard driving method) Wear resistance: 150km (at 12.5% print ratio)	
	Cutter	-	1,000,000 cuts minimum
	Platen	5,000 times (open/close)	
Environmental conditions	Operating temperature	-20°C to +70°C (guarantee)	-20°C to +70°C (guarantee)
	Operating humidity	20 to 85% RH (no condensation)	
	Storage temperature	-25°C to +75°C	-25°C to +75°C
	Storage humidity	5 to 95% RH (no condensation)	
Detection	Head temperature	By thermistor	
	Paper out/Mark detect	By photointerruptor	
	Head release	By slide switch	
Recommended thermal sensitive paper	High sensitive paper	TF50KS-E4 (Nippon paper)	
	Standard paper	TF60KS-E2 (Nippon paper), FTP-030P0104 (80mm) PD150R (Oji paper), FTP-030P0701 (80mm)	
	Medium life storage paper	TF60KS-F1 (Nippon paper), FTP-030P0102 (80mm) PD170R (Oji paper) P220VBB-1 (Mitsubishi paper) PD160R-N (Oji paper)	
	Long life storage paper	AFP-235 (Mitsubishi paper) TP50KJ-R (Nippon paper) HA220AA (Nippon paper)	

# FTP-63AMCL001/011/401/411

## ■ DIMENSIONS

### 1. Printer mechanism

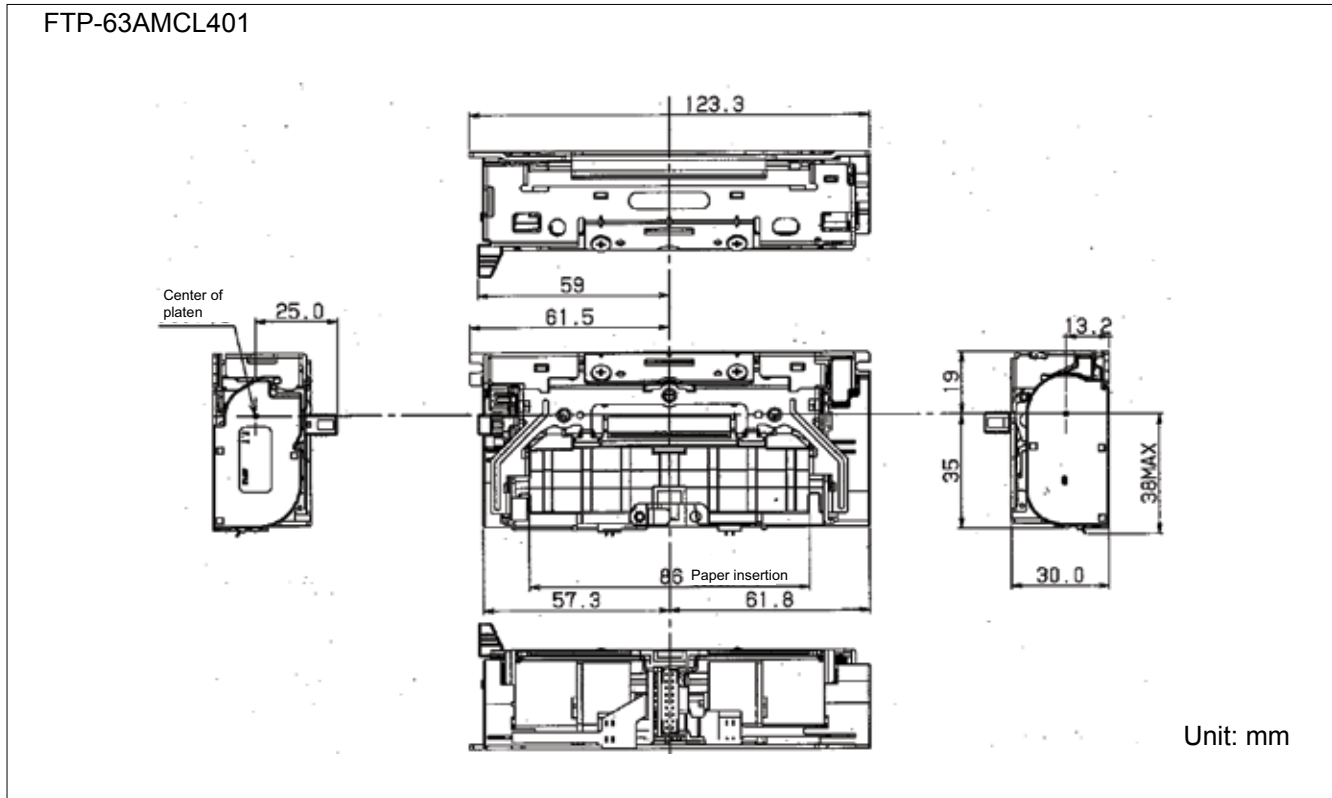
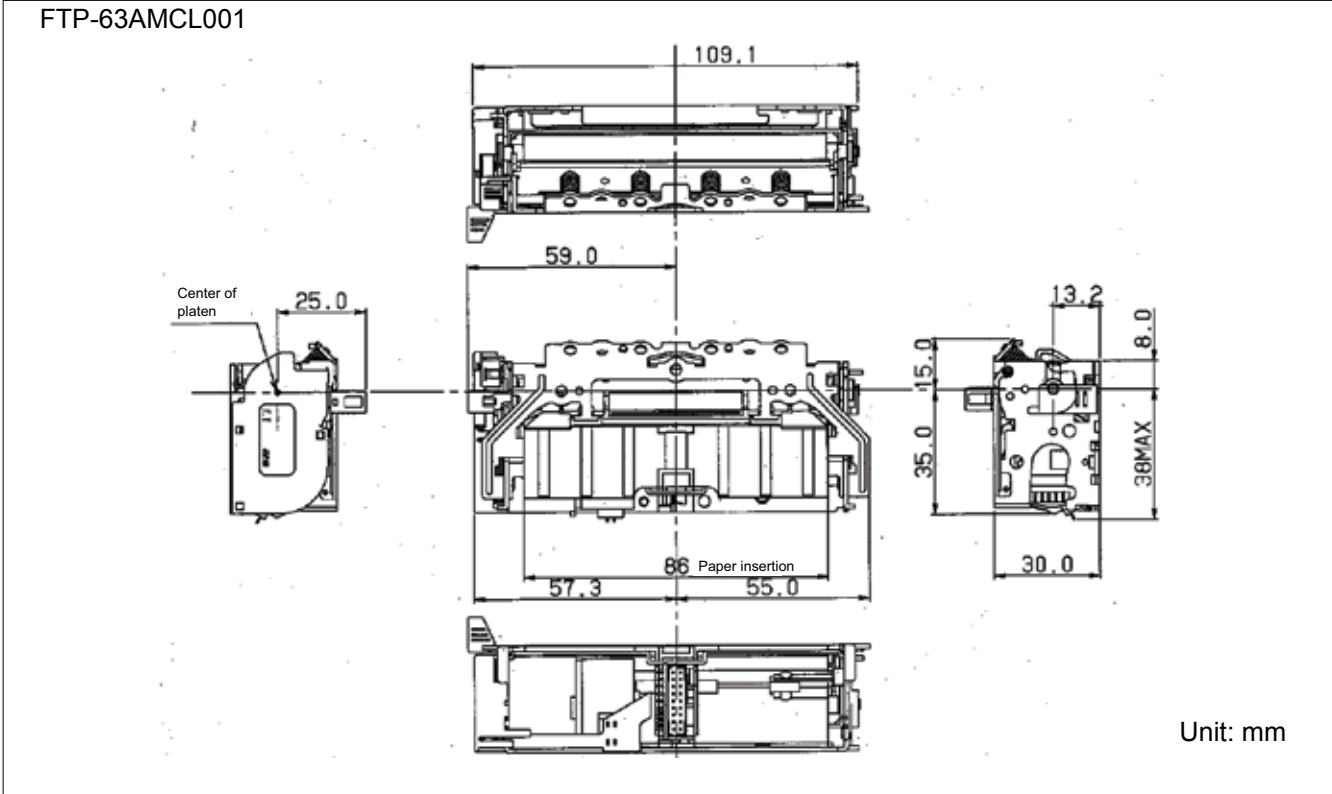

## ■ CONNECTOR PIN ASSIGNMENT OF PRINTER MECHANISM (FPC)

### 1. Thermal head control circuit side

#### a. FPC type (FTP-63AMCL001/401)

Printer mechanism side: FPC / FFC  
Control circuit side: for 1.25mm pitch x 28pins

#### b. Adaptor Board type (FTP-63AMCL011/411)

Printer mechanism side: B28B-PHDSS (J.S.T)  
Control circuit side: PHDR-28VS (J.S.T)

No.	Signal	I/O	Contents	No.	Signal	I/O	Contents
1	VH		Head drive power	2	VH		Head drive power
3	VH		Head drive power	4	VH		Head drive power
5	DO 1	O	Data out 1	6	DI 1		Data in 1
7	GND	-	Head ground	8	GND	-	Head ground
9	GND	-	Head ground	10	GND	-	Head ground
11	GND	-	Head ground	12	STB 1		Strobe 1
13	CLK		Clock	14	LAT		Data latch
15	Vdd		Logic	16	TH	O	Thermistor
17	TH	O	Thermistor	18	STB 2		Strobe 2
19	GND	-	Ground	20	GND	-	Ground
21	GND	-	Ground	22	GND	-	Ground
23	DO 2	O	Data out 2	24	DI 2		Data in 2
25	VH		Head drive power	26	VH		Head drive power
27	VH		Head drive power	28	VH		Head drive power

### 2. Motor, Sensor (CN4)

Printer mechanism side: LY20-18P-DLT1-P1E (JAE)  
Control circuit side: LY10-DC18 (JAE)

#### FTP-63AMCL001/011

No.	Signal	I/O	Contents	No.	Signal	I/O	Contents
1	N.C.	-	Not connected	2	N.C.	-	Not connected
3	N.C.	-	Not connected	4	N.C.	-	Not connected
5	N.C.	-	Not connected	6	N.C.	-	Not connected
7	N.C.	-	Not connected	8	TH	-	Thermistor
9	TH	-	Thermistor	10	PHK-P	-	Paper detection photointerruptor (cathode)
11	MT A		Motor excitation signal A	12	PHE-P	O	Paper detection photointerruptor (emitter)
13	MT B		Motor excitation signal B	14	VSEN		Power supply for photointerruptor
15	MT A		Motor excitation signal A	16	PHK-L	-	Lever detection photointerruptor (cathode)
17	MT B		Motor excitation signal B	18	PHE-L	O	Lever detection photointerruptor (emitter)

## FTP-63AMCL401/411

No.	Signal	I/O	Contents	No.	Signal	I/O	Contents
1	MT A		Motor excitation signal A (cutter)	2	MT $\bar{B}$		Motor excitation signal $\bar{B}$ (cutter)
3	MT B		Motor excitation signal B (cutter)	4	MT $\bar{A}$		Motor excitation signal $\bar{A}$ (cutter)
5	VSEN		Power supply for photointerruptor	6	PHE-C	O	Cutter photointerruptor (emitter)
7	PHK-C	-	Cutter photointerruptor (cathode)	8	TH	O	Thermistor
9	TH	O	Thermistor	10	PHK-P	-	Paper detection photointerruptor (cathode)
11	MT A		Motor excitation signal A (paper)	12	PHE-P	O	Paper detection photointerruptor (emitter)
13	MT $\bar{B}$		Motor excitation signal $\bar{B}$ (paper)	14	VSEN		Power supply for photointerruptor
15	MT B		Motor excitation signal B (paper)	16	PHK-L	-	Lever detection photointerruptor (cathode)
17	MT $\bar{A}$		Motor excitation signal $\bar{A}$ (paper)	18	PHE-L	O	Lever detection photointerruptor (emitter)

## ■ INTERFACE COMMAND OPTIONS

Please refer to the FTP-62ADSL series datasheet

## Fujitsu Components International Headquarter Offices

<p><b>Japan</b>            Fujitsu Component Limited            Gotanda-Chuo Building            3-5, Higashigotanda 2-chome, Shinagawa-ku            Tokyo 141, Japan            Tel: (81-3) 5449-7010            Fax: (81-3) 5449-2626            Email: <a href="mailto:promothq@ft.ed.fujitsu.com">promothq@ft.ed.fujitsu.com</a>            Web: <a href="http://www.fcl.fujitsu.com">www.fcl.fujitsu.com</a></p>	<p><b>Europe</b>            Fujitsu Components Europe B.V.            Diamantlaan 25            2132 WV Hoofddorp            Netherlands            Tel: (31-23) 5560910            Fax: (31-23) 5560950            Email: <a href="mailto:info@fceu.fujitsu.com">info@fceu.fujitsu.com</a>            Web: <a href="http://emea.fujitsu.com/components/">emea.fujitsu.com/components/</a></p>
<p><b>North and South America</b>            Fujitsu Components America, Inc.            250 E. Caribbean Drive            Sunnyvale, CA 94089 U.S.A.            Tel: (1-408) 745-4900            Fax: (1-408) 745-4970            Email: <a href="mailto:components@us.fujitsu.com">components@us.fujitsu.com</a>            Web: <a href="http://us.fujitsu.com/thermal-printers/">http://us.fujitsu.com/thermal-printers/</a></p>	<p><b>Asia Pacific</b>            Fujitsu Components Asia Ltd.            102E Pasir Panjang Road            #01-01 Citilink Warehouse Complex            Singapore 118529            Tel: (65) 6375-8560            Fax: (65) 6273-3021            Email: <a href="mailto:fcal@fcal.fujitsu.com">fcal@fcal.fujitsu.com</a>            Web: <a href="http://www.fujitsu.com/sg/services/micro/components/">http://www.fujitsu.com/sg/services/micro/components/</a></p>

©2013 Fujitsu Components America, Inc. All rights reserved. All trademarks or registered trademarks are the property of their respective owners.

Fujitsu Components America or its affiliates do not warrant that the content of datasheet is error free. In a continuing effort to improve our products Fujitsu Components America, Inc. or its affiliates reserve the right to change specifications/datasheets without prior notice.  
 Rev. April 24, 2013.



Компания «ЭлектроПласт» предлагает заключение долгосрочных отношений при поставках импортных электронных компонентов на взаимовыгодных условиях!

Наши преимущества:

- Оперативные поставки широкого спектра электронных компонентов отечественного и импортного производства напрямую от производителей и с крупнейших мировых складов;
- Поставка более 17-ти миллионов наименований электронных компонентов;
- Поставка сложных, дефицитных, либо снятых с производства позиций;
- Оперативные сроки поставки под заказ (от 5 рабочих дней);
- Экспресс доставка в любую точку России;
- Техническая поддержка проекта, помощь в подборе аналогов, поставка прототипов;
- Система менеджмента качества сертифицирована по Международному стандарту ISO 9001;
- Лицензия ФСБ на осуществление работ с использованием сведений, составляющих государственную тайну;
- Поставка специализированных компонентов (Xilinx, Altera, Analog Devices, Intersil, Interpoint, Microsemi, Aeroflex, Peregrine, Syfer, Eurofarad, Texas Instrument, Miteq, Cobham, E2V, MA-COM, Hittite, Mini-Circuits, General Dynamics и др.);

Помимо этого, одним из направлений компании «ЭлектроПласт» является направление «Источники питания». Мы предлагаем Вам помощь Конструкторского отдела:

- Подбор оптимального решения, техническое обоснование при выборе компонента;
- Подбор аналогов;
- Консультации по применению компонента;
- Поставка образцов и прототипов;
- Техническая поддержка проекта;
- Защита от снятия компонента с производства.



#### Как с нами связаться

**Телефон:** 8 (812) 309 58 32 (многоканальный)

**Факс:** 8 (812) 320-02-42

**Электронная почта:** [org@eplast1.ru](mailto:org@eplast1.ru)

**Адрес:** 198099, г. Санкт-Петербург, ул. Калинина, дом 2, корпус 4, литера А.