

SPECIFICATION

- Part No.** : **CGGP.18.2.A.02**
- Description** : GPS/GLONASS Dual-Band Ceramic Patch
Embedded Antenna 18x18x2mm
- Features** : Wide-band Operation 1575-1610MHz
3.23dBi Peak Gain for GPS Band
3.53dBi Peak Gain for GLONASS Band
Low profile – 2mm Height
Through-hole Mounting Pin type
Automotive TS16949 Production and Quality
Approved
RoHS compliant



1. Introduction

The CGGP.18.2.A.02 is a 18mm ceramic GPS/Glonass embedded passive patch antenna, with a 2mm low profile. It is designed for vehicle telematic applications as well as other M2M/IoT devices. Typical applicable industries are transportation, defense, marine, agriculture, and navigation.

The antenna has been tuned and tested on a 70 x 70 mm ground plane, working at GPS 1575.42MHz and GLONASS 1602MHz, with 3.23dBi gain and 3.53dBi gain, respectively. The low profile design makes this antenna perfect for applications where space is limited. It can be easily through-hole mounted on PCB via pin. Double sided adhesive on the bottom of the patch helps to keep it in place while undergoing mounting. The CGGP.18.2.A.02 is manufactured and tested in a TS16949 first tier automotive approved facility.

Like all antennas, at least some detuning will occur when placed in a different device environment or on a different ground-plane.

For large volume GPS/GLONASS projects where performance is paramount, tuning for customer specific device environment and ground-plane size is needed, so custom tuned patch antennas should always be used. Taoglas can also provide different pin length for these antennas, all subject to potential NRE and MOQ. For more details please contact [your regional Taoglas sales office.](#)

2. Specification

ELECTRICAL		
Application Bands	GPS	GLONASS
Operation Frequency (MHz)	1575.42 ±1.023	1602±5
Return Loss (dB)	-10 max.	
Gain at Zenith (dBi)	3.23	3.53
Efficiency (%)	54.88	59.52
Impedance	50 ohms	
MECHANICAL		
Ceramic Dimension (mm)	18 x 18 x 2	
Pin Diameter (mm)	0.9	
Pin Length (mm)	2.25	
Weight (g)	2.5	
ENVIRONMENTAL		
Operation Temperature	-40°C to 85°C	
Humidity	Non-condensing 65°C 95% RH	

* Antenna properties were measured with the antenna mounted on 70*70mm Ground Plane
Taoglas Part # CGGPD.18.D

3. Antenna Characteristics

3.1 Return Loss

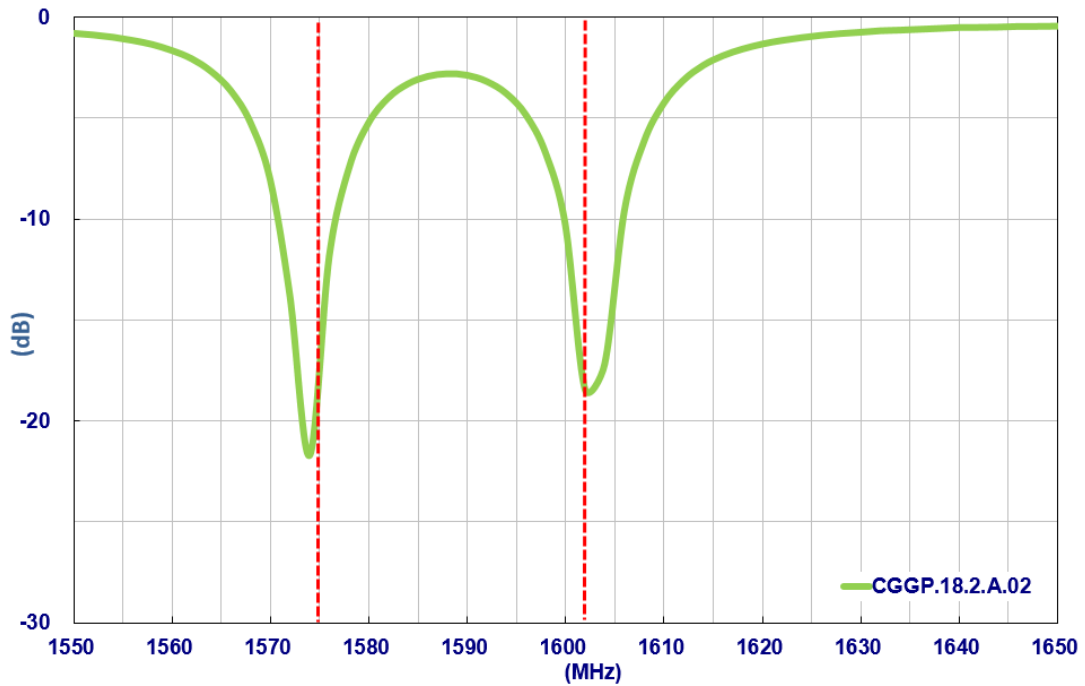

3.2 Efficiency

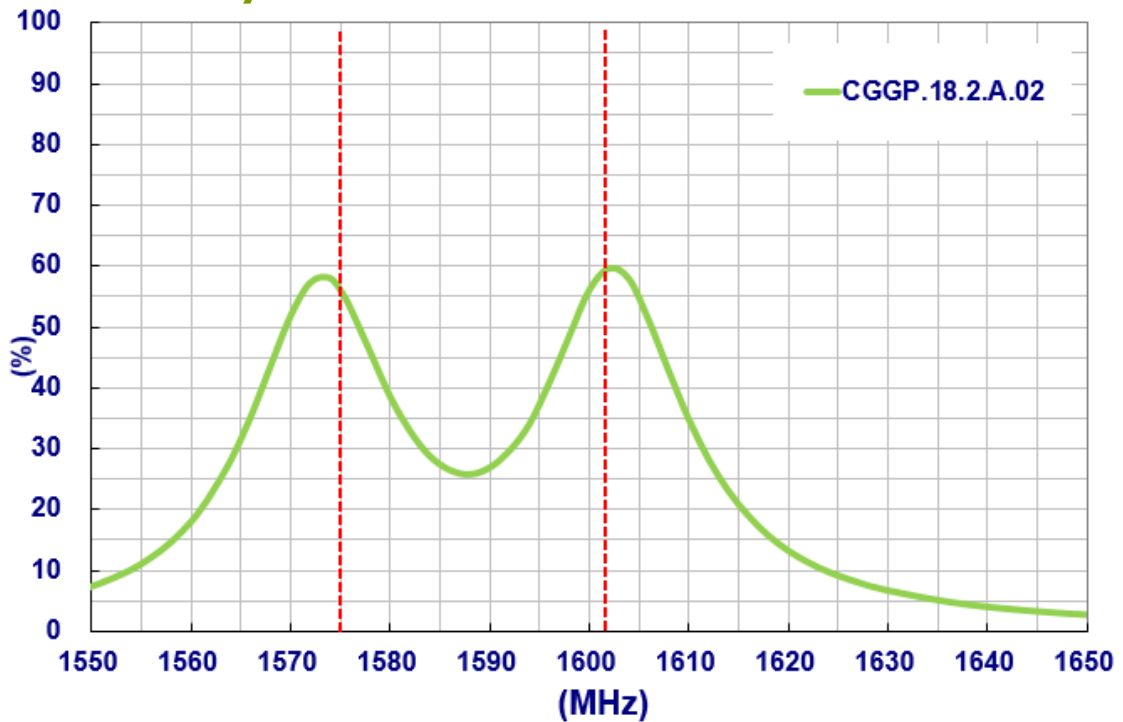

3.3 Average Gain

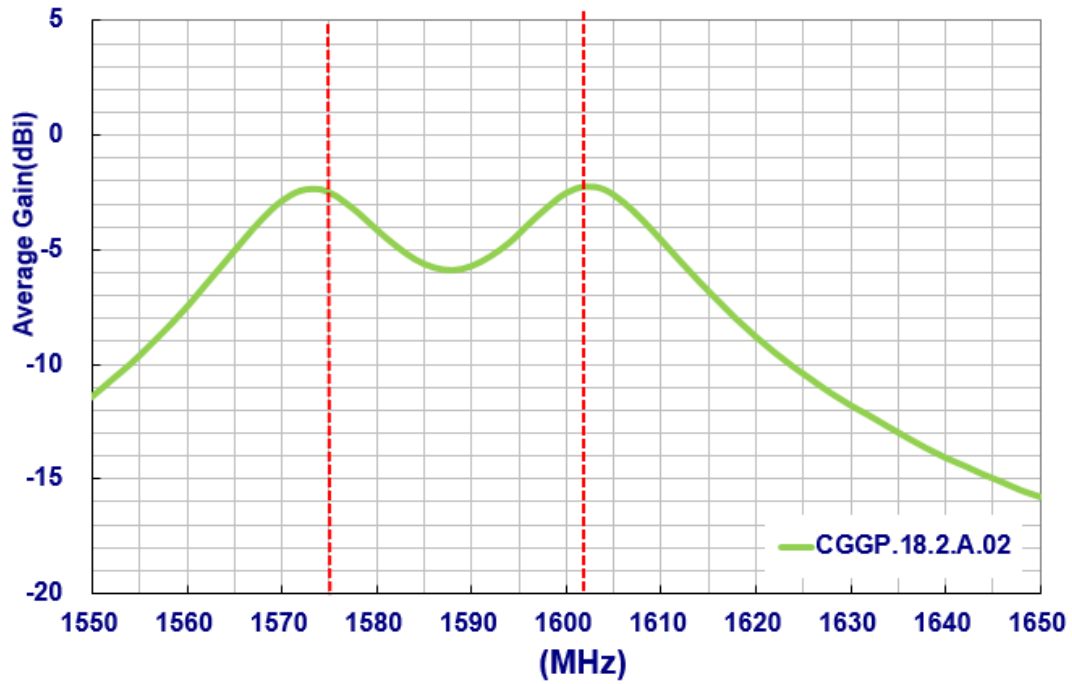

3.4 Peak Gain

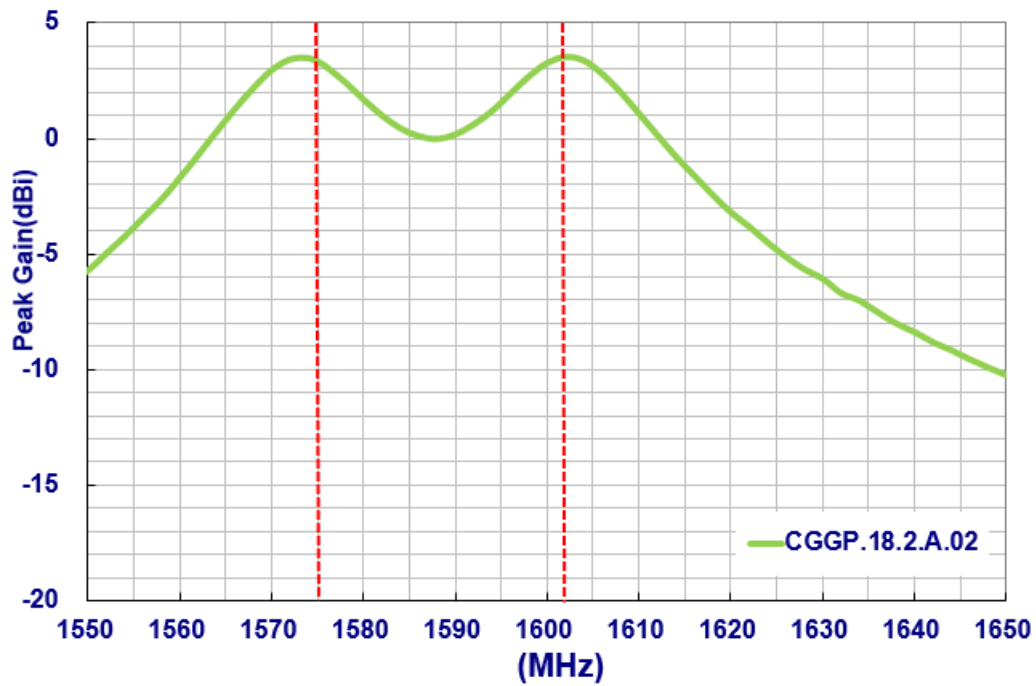

4. Antenna Radiation Pattern

4.1. Measurement Setup

The CGGP.18.2.A.02 antenna is tested in free-space on a 70mm*70mm ground plane in a CTIA certified ETS-Lindgren Anechoic Chamber. The test setup is shown below.

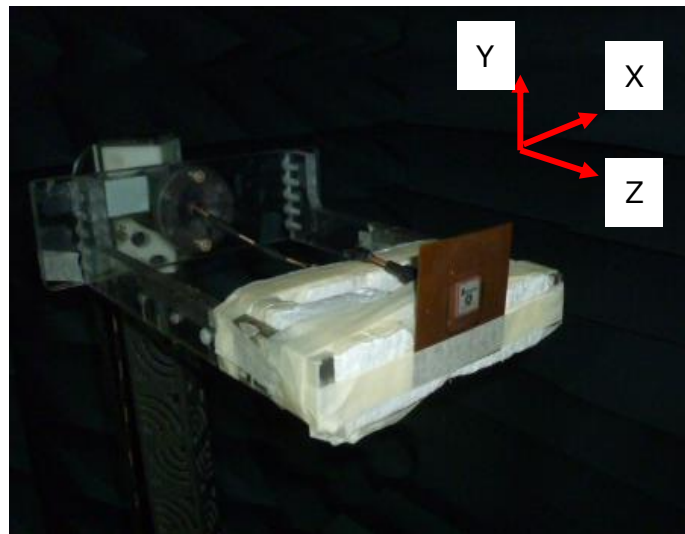

4.2. 2D Radiation Pattern

XY Plane

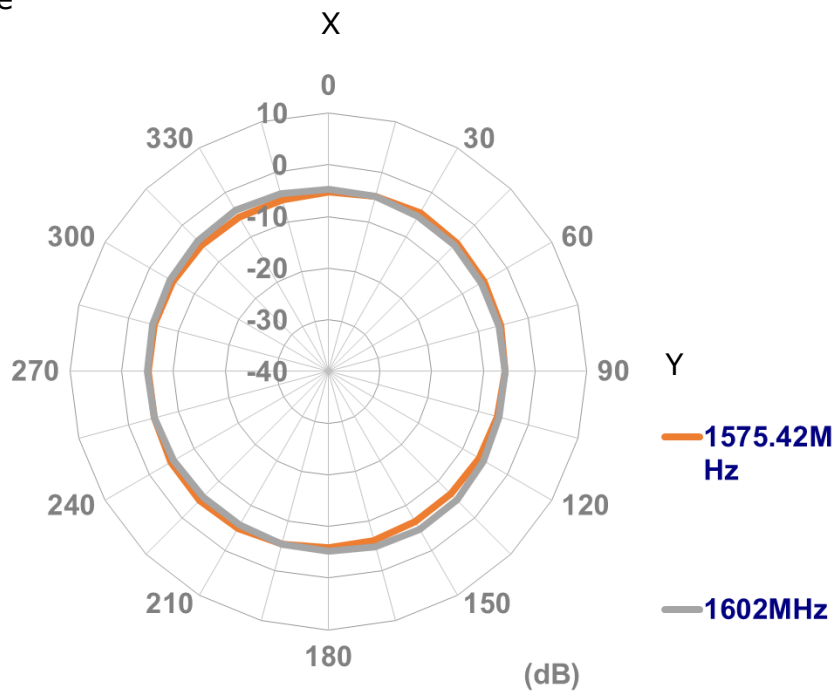

XZ Plane

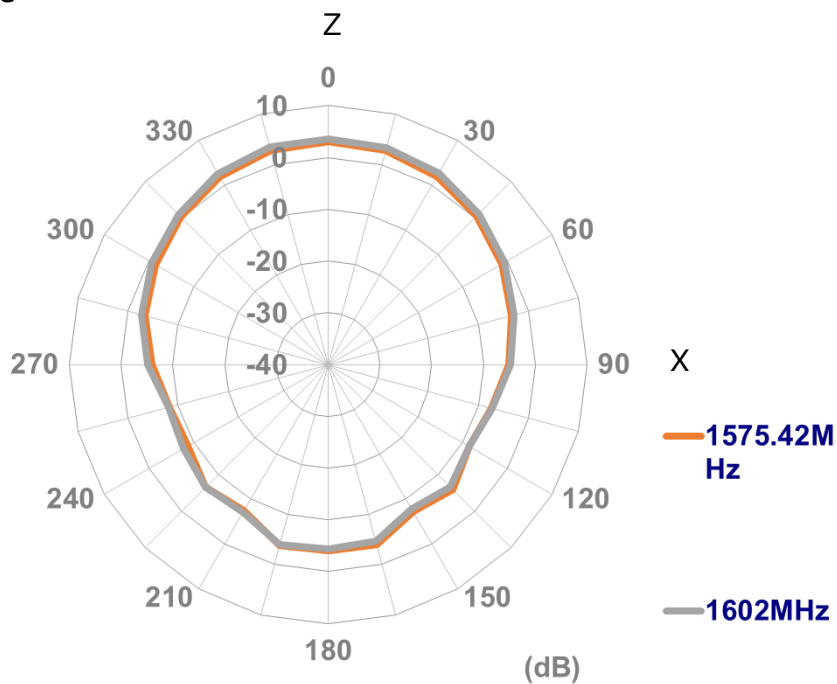

YZ Plane

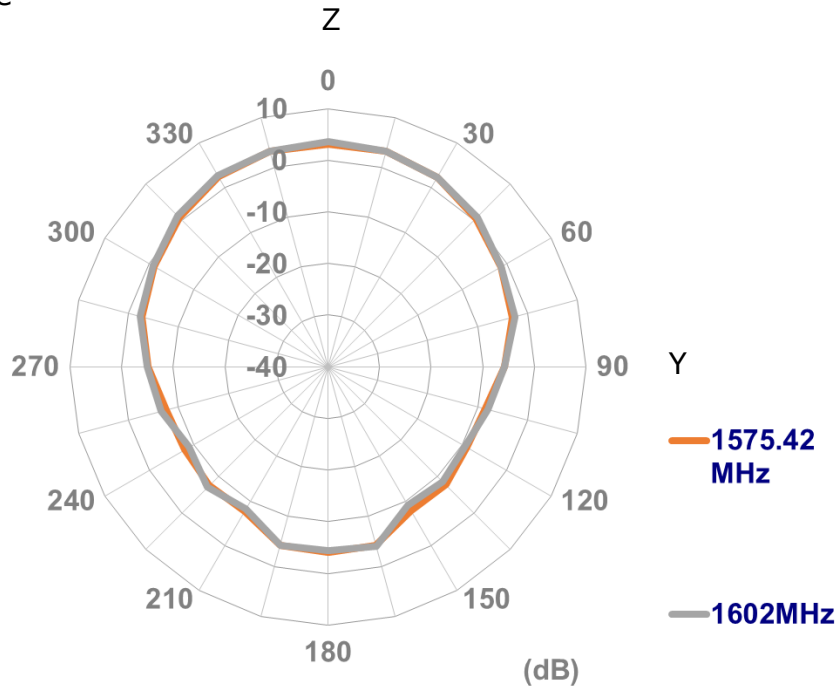

4.3. 3D Radiation Pattern

1575.42MHz

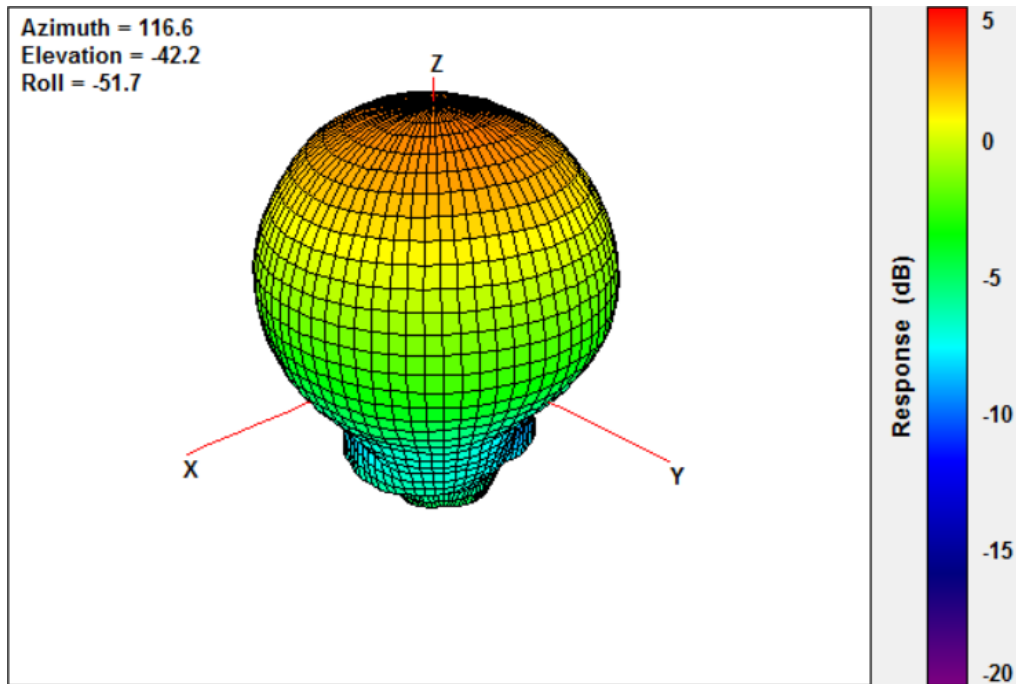

1602MHz

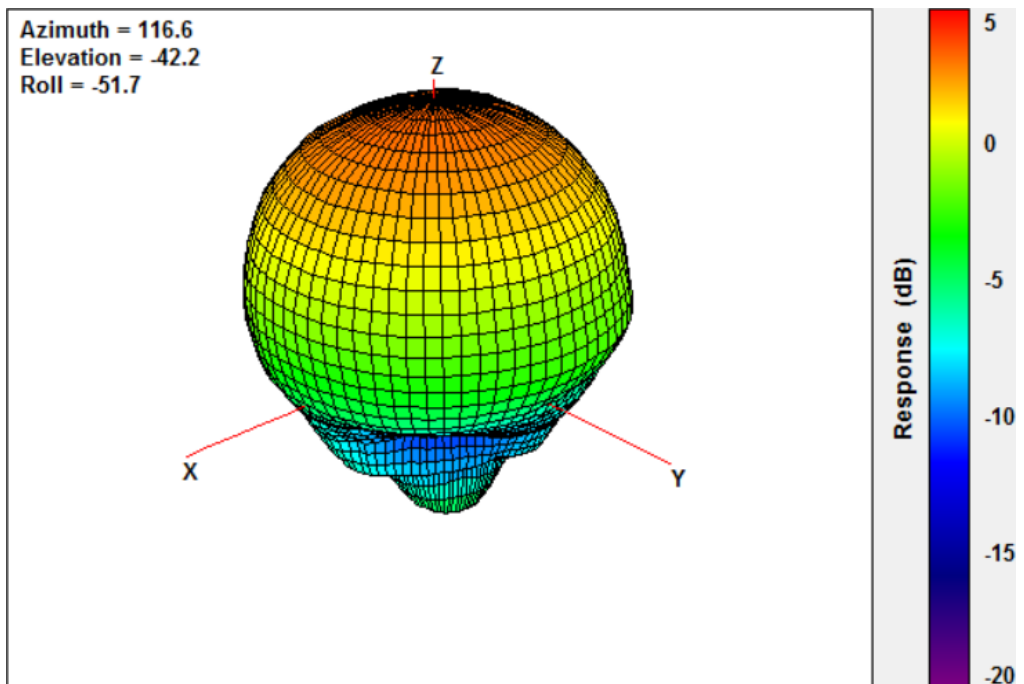

5. Mechanical Drawing

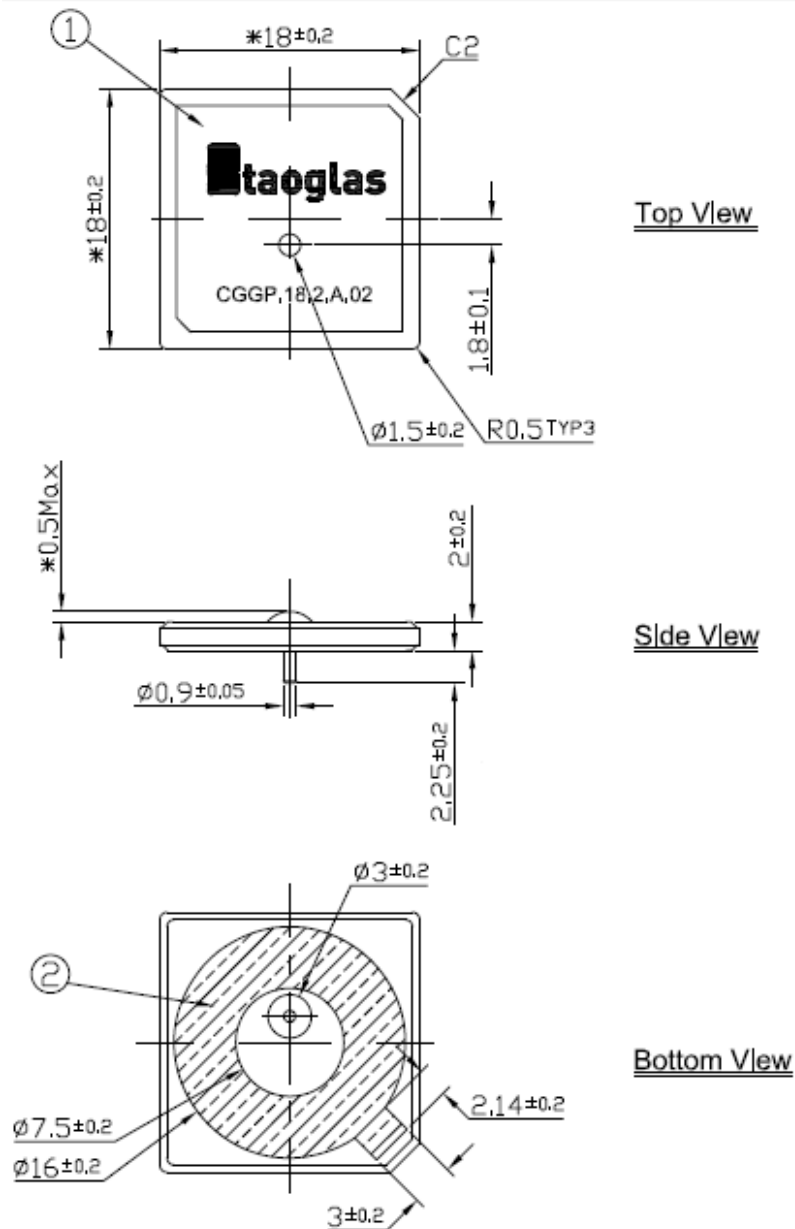

NOTES:

1. Double sided adhesive area 

	Name	P/N	Material	Finish	QTY
1	Patch 18x18x2	001513C110007A	Ceramic	Clear	1
2	Double sided Adhesive	001013C050007A	NITTO 5015	White Liner	1

Unit:mm

5.1 Adhesive Thickness

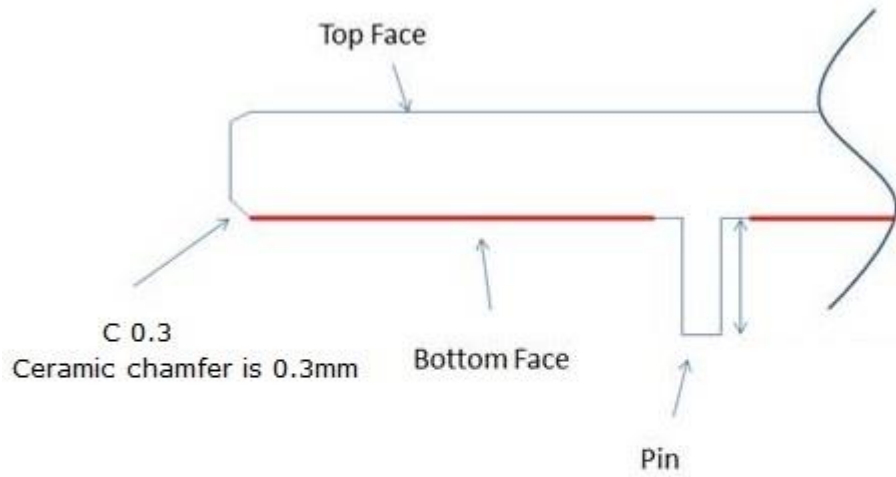

Red Line shows the adhesive without Liner - thickness 0.08~0.1mm

6. Evaluation Board (CGGPD.18.D)

Top View

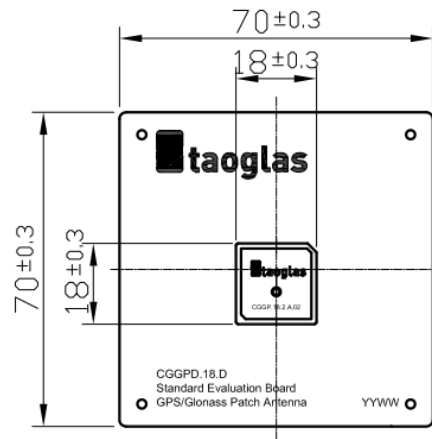

Side View

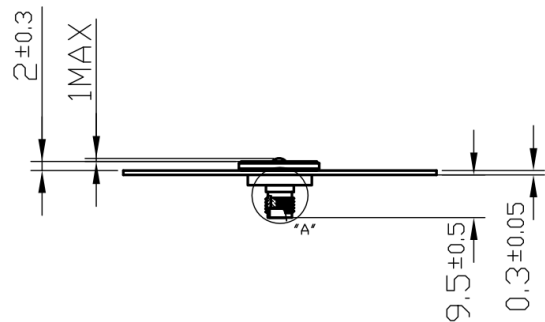

Bottom View

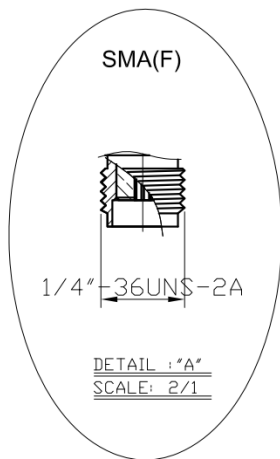
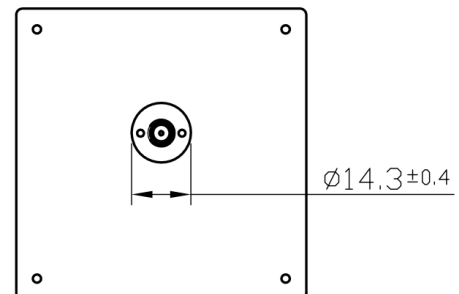

Unit:mm

	Name	Material	Finish	QTY
1	Patch(18x18x4mm)	Ceramic	Clear	1
2	Ground-Plane(70x70x0.3mm)	Brass	Silver	1
3	SMA(F) ST	Brass	Gold	1

7. PCB Footprint Recommendation

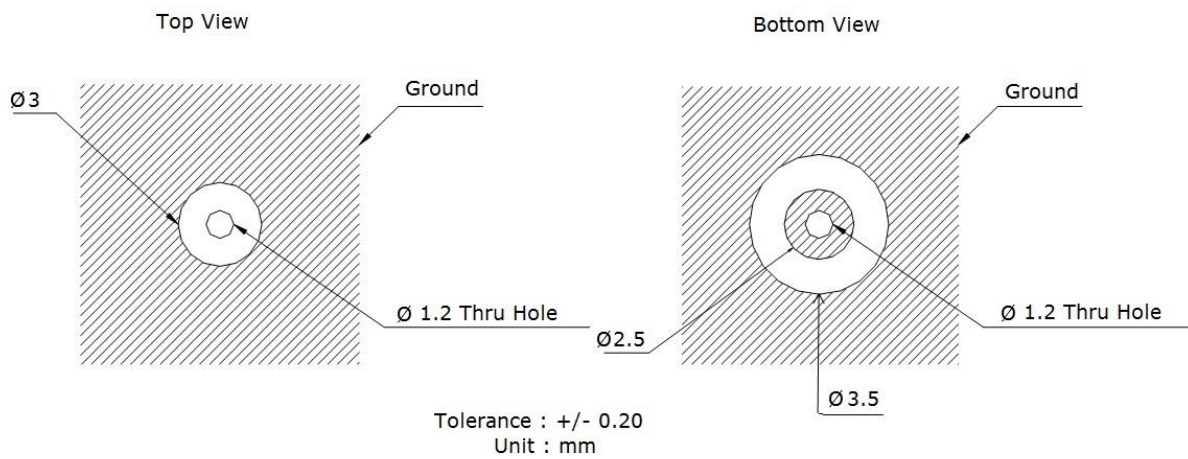

8. Packaging

8.1. Inner Tray & Inner Carton

CGGP.18.2.A.02

Packaging Specifications

25 pcs per tray
 Tray Dimensions - 250*150*11mm

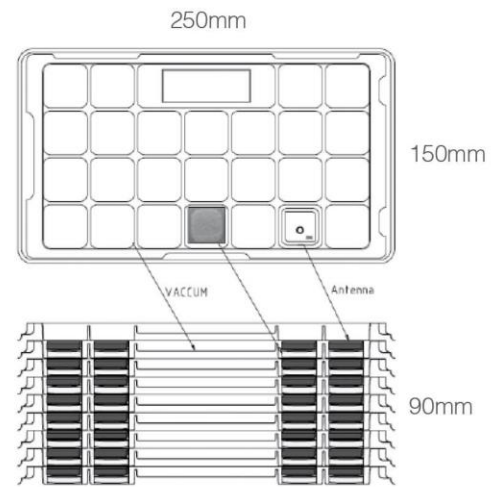

8 Trays per inner box
 200 pcs CGGP.18.2.A.02
 Dimensions - 260*160*100mm

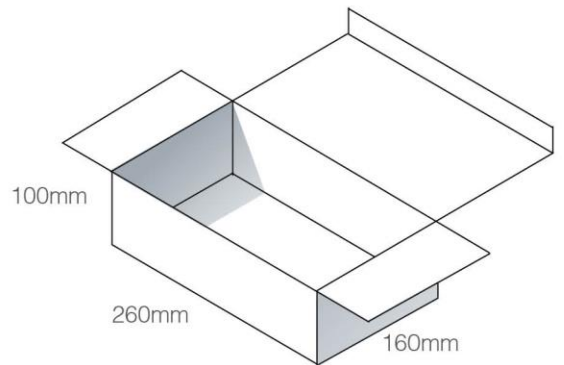

8.2. Carton

4 inner boxes per outer carton
800 Pieces CGGP.18.2.A.02 per carton
Carton Dimensions - 330*280*270mm

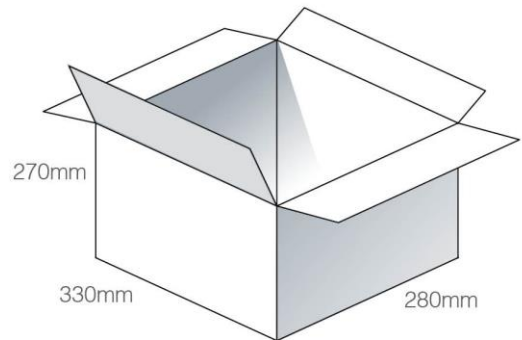

Pallet Dimensions 1100*1100*1500mm
60 Cartons per Pallet
12 Cartons per layer
5 Layers

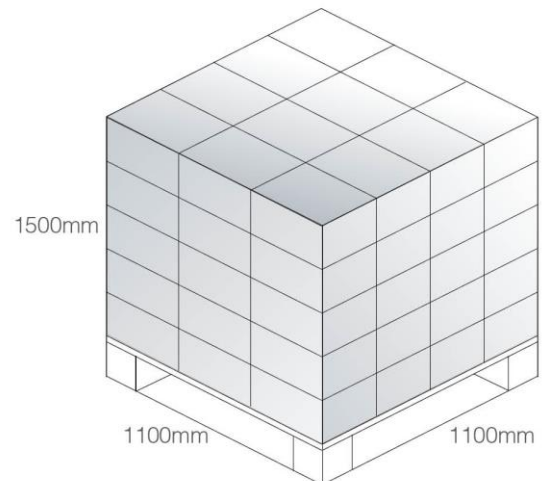



Компания «ЭлектроПласт» предлагает заключение долгосрочных отношений при поставках импортных электронных компонентов на взаимовыгодных условиях!

Наши преимущества:

- Оперативные поставки широкого спектра электронных компонентов отечественного и импортного производства напрямую от производителей и с крупнейших мировых складов;
- Поставка более 17-ти миллионов наименований электронных компонентов;
- Поставка сложных, дефицитных, либо снятых с производства позиций;
- Оперативные сроки поставки под заказ (от 5 рабочих дней);
- Экспресс доставка в любую точку России;
- Техническая поддержка проекта, помощь в подборе аналогов, поставка прототипов;
- Система менеджмента качества сертифицирована по Международному стандарту ISO 9001;
- Лицензия ФСБ на осуществление работ с использованием сведений, составляющих государственную тайну;
- Поставка специализированных компонентов (Xilinx, Altera, Analog Devices, Intersil, Interpoint, Microsemi, Aeroflex, Peregrine, Syfer, Eurofarad, Texas Instrument, Miteq, Cobham, E2V, MA-COM, Hittite, Mini-Circuits, General Dynamics и др.);

Помимо этого, одним из направлений компании «ЭлектроПласт» является направление «Источники питания». Мы предлагаем Вам помощь Конструкторского отдела:

- Подбор оптимального решения, техническое обоснование при выборе компонента;
- Подбор аналогов;
- Консультации по применению компонента;
- Поставка образцов и прототипов;
- Техническая поддержка проекта;
- Защита от снятия компонента с производства.



Как с нами связаться

Телефон: 8 (812) 309 58 32 (многоканальный)

Факс: 8 (812) 320-02-42

Электронная почта: org@eplast1.ru

Адрес: 198099, г. Санкт-Петербург, ул. Калинина, дом 2, корпус 4, литера А.