

7/8-Bit Single, +36V ($\pm 18V$) Digital POT with SPI Serial Interface and Volatile Memory

Features

- High-Voltage Analog Support:
 - +36V Terminal Voltage Range (DGND = V-)
 - $\pm 18V$ Terminal Voltage Range (DGND = V- + 18V)
- Wide Operating Voltage:
 - Analog: 10V to 36V (specified performance)
 - Digital: 2.7V to 5.5V
1.8V to 5.5V (DGND \geq V- + 0.9V)
- Single Resistor Network
- Potentiometer Configuration Options
- Resistor Network Resolution
 - 7-bit: 127 Resistors (128 Taps)
 - 8-bit: 255 Resistors (256 Taps)
- R_{AB} Resistance Options:
 - 5 k Ω – 10 k Ω
 - 50 k Ω – 100 k Ω
- High Terminal/Wiper Current (I_W) Support:
 - 25 mA (for 5 k Ω)
 - 12.5 mA (for 10 k Ω)
 - 6.5 mA (for 50 k Ω and 100 k Ω)
- Zero-Scale to Full-Scale Wiper Operation
- Low Wiper Resistance: 75 Ω (Typical)
- Low Tempco:
 - Absolute (Rheostat): 50 ppm Typical (0°C to +70°C)
 - Ratiometric (Potentiometer): 15 ppm Typical
- SPI Serial Interface (10 MHz, Modes 0, 0 and 1, 1)
- Resistor Network Terminal Disconnect Via:
 - Shutdown Pin (SHDN)
 - Terminal Control (TCON) Register
- Write Latch (WLAT) Pin to control update of Volatile Wiper Register (such as Zero Crossing)
- Power-On Reset / Brown-Out Reset for both:
 - Digital Supply (V_L/DGND); 1.5V Typical
 - Analog Supply (V+ / V-); 3.5V Typical
- Serial Interface Inactive Current (3 μ A Typical)
- 500 kHz Typical Bandwidth (-3 dB) Operation (5.0 k Ω Device)
- Extended Temperature Range (-40°C to +125°C)
- Package Types: TSSOP-14 and QFN-20 (5x5)

Package Types (Top View)

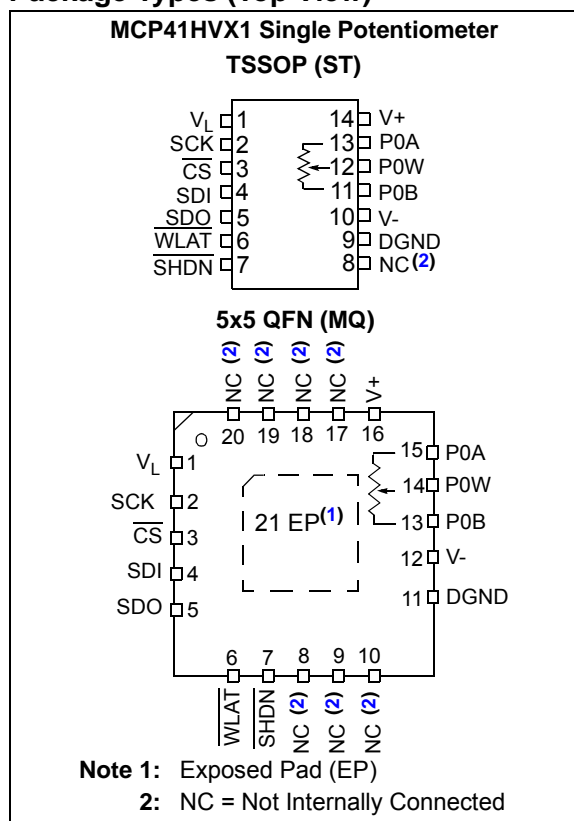

Description

The MCP41HVX1 family of devices have dual power rails (analog and digital). The analog power rail allows high voltage on the resistor network terminal pins. The analog voltage range is determined by the V+ and V- voltages. The maximum analog voltage is +36V, while the operating analog output minimum specifications are specified from either 10V or 20V. As the analog supply voltage becomes smaller, the analog switch resistances increase, which effect certain performance specifications. The system can be implemented as dual rail ($\pm 18V$) relative to the digital logic ground (DGND).

The device also has a Write Latch (WLAT) function, which will inhibit the volatile wiper register from being updated (latched) with the received data, until the WLAT pin is low. This allows the application to specify a condition where the volatile wiper register is updated (such as zero crossing).

MCP41HVX1

Device Block Diagram



Device Features

| Device | # of POTS | Wiper Configuration | Control Interface | POR Wiper Setting | Resistance (Typical) | | Number of: | | Specified Operating Range | |
|-----------|-----------|---------------------|-------------------|-------------------|------------------------------|--------------------------|----------------|------|---------------------------|--------------------|
| | | | | | R _{AB} Options (kΩ) | Wiper-R _W (Ω) | R _S | Taps | V _L (2) | V ₊ (3) |
| MCP41HV31 | 1 | Potentiometer (1) | SPI | 3Fh | 5.0, 10.0, 50.0, 100.0 | 75 | 127 | 128 | 1.8V to 5.5V | 10V (4) to 36V |
| MCP41HV51 | 1 | Potentiometer (1) | SPI | 7Fh | 5.0, 10.0, 50.0, 100.0 | 75 | 255 | 256 | 1.8V to 5.5V | 10V (4) to 36V |

- Note 1:** Floating either terminal (A or B) allows the device to be used as a Rheostat (variable resistor).
- 2:** This is relative to the DGND signal. There is a separate requirement for the V₊ / V₋ voltages. When V_L = 1.8V operation, DGND must be 0.9V above V₋.
- 3:** Relative to V₋, the V_L and DGND signals must be between V₋ and V₊.
- 4:** Analog operation will continue while the V₊ voltage is above the device's Analog Power-on Reset (POR) / Brown-out Reset (BOR) voltage. Operational characteristics may exceed specified limits while the V₊ voltage is below the specified minimum voltage.

1.0 ELECTRICAL CHARACTERISTICS

Absolute Maximum Ratings †

| | |
|--|--|
| Voltage on V- with respect to DGND | DGND + 0.6V to -40.0V |
| Voltage on V+ with respect to DGND | DGND - 0.3V to 40.0V |
| Voltage on V+ with respect to V- | DGND - 0.3V to 40.0V |
| Voltage on V _L with respect to V+ | -0.6V to -40.0V |
| Voltage on V _L with respect to V- | -0.6V to +40.0V |
| Voltage on V _L with respect to DGND | -0.6V to +7.0V |
| Voltage on $\overline{\text{CS}}$, SCK, SDI, $\overline{\text{WLAT}}$, and $\overline{\text{SHDN}}$ with respect to DGND | -0.6V to V _L + 0.6V |
| Voltage on all other pins (Px _A , Px _W , and Px _B) with respect to V- | -0.3V to V+ + 0.3V |
| Input clamp current, I _{IK} (V _I < 0, V _I > V _L , V _I > V _{PP} on HV pins) | ±20 mA |
| Output clamp current, I _{OK} (V _O < 0 or V _O > V _L) | ±20 mA |
| Maximum current out of DGND pin | 100 mA |
| Maximum current into V _L pin | 100 mA |
| Maximum current out of V- pin | 100 mA |
| Maximum current into V+ pin | 100 mA |
| Maximum current into Px _A , Px _W , & Px _B pins (Continuous) | |
| R _{AB} = 5 kΩ | ±25 mA |
| R _{AB} = 10 kΩ | ±12.5 mA |
| R _{AB} = 50 kΩ | ±6.5 mA |
| R _{AB} = 100 kΩ | ±6.5 mA |
| Maximum current into Px _A , Px _W , & Px _B pins (Pulsed) | |
| F _{PULSE} > 10 kHz | (Max I _{Continuous}) / (Duty Cycle) |
| F _{PULSE} ≤ 10 kHz | (Max I _{Continuous}) / √(Duty Cycle) |
| Maximum output current sunk by any Output pin | 25 mA |
| Maximum output current sourced by any Output pin | 25 mA |
| Package Power Dissipation (T _A = + 50°C, T _J = +150°C) | |
| TSSOP-14 | 1000 mW |
| SOIC-16 | 1250 mW |
| QFN-20 (5 x 5) | 2800 mW |
| QFN-20 (4x4) | 2300 mW |
| Soldering temperature of leads (10 seconds) | +300°C |
| ESD protection on all pins | |
| Human Body Model (HBM) | ≥ ±4 kV |
| Machine Model (MM) | ≥ ±400V |
| Maximum Junction Temperature (T _J) | 150°C |
| Storage temperature | -65°C to +150°C |
| Ambient temperature with power applied | -40°C to +125°C |

† **Notice:** Stresses above those listed under “Maximum Ratings” may cause permanent damage to the device. This is a stress rating only and functional operation of the device at those or any other conditions above those indicated in the operational listings of this specification is not implied. Exposure to maximum rating conditions for extended periods may affect device reliability.

MCP41HVX1

AC/DC CHARACTERISTICS

| DC Characteristics | | Standard Operating Conditions (unless otherwise specified) | | | | |
|---|-------------------|---|-----|-------------|-------|--|
| | | Operating Temperature $-40^{\circ}\text{C} \leq T_A \leq +125^{\circ}\text{C}$ (extended) | | | | |
| | | All parameters apply across the specified operating ranges unless noted. | | | | |
| | | $V_+ = 10\text{V to } 36\text{V}$ (referenced to V_-); | | | | |
| | | $V_+ = +5\text{V to } +18\text{V}$ & $V_- = -5.0\text{V to } -18\text{V}$ (referenced to DGND $\rightarrow \pm 5\text{V to } \pm 18\text{V}$), | | | | |
| | | $V_L = +2.7\text{V to } 5.5\text{V}$, 5 k Ω , 10 k Ω , 50 k Ω , 100 k Ω devices. | | | | |
| | | Typical specifications represent values for $V_L = 5.5\text{V}$, $T_A = +25^{\circ}\text{C}$. | | | | |
| Parameters | Sym | Min | Typ | Max | Units | Conditions |
| Digital Positive Supply Voltage (V_L) | V_L | 2.7 | — | 5.5 | V | With respect to DGND (Note 4) |
| | | 1.8 | — | 5.5 | V | DGND = $V_- + 0.9\text{V}$ (referenced to V_-) (Note 1, Note 4) |
| | | — | — | 0 | V | With respect to V_+ |
| Analog Positive Supply Voltage (V_+) | V_+ | V_L (16) | — | 36.0 | V | With respect to V_- (Note 4) |
| Digital Ground Voltage (DGND) | V_{DGND} | V_- | — | $V_+ - V_L$ | V | With respect to V_- (Note 4, Note 5) |
| Analog Negative Supply Voltage (V_-) | V_- | $-36.0 + V_L$ | — | 0 | V | With respect to DGND and $V_L = 1.8\text{V}$ |
| Resistor Network Supply Voltage | V_{RN} | — | — | 36V | V | Delta voltage between V_+ and V_- (Note 4) |
| V_L Start Voltage to ensure Wiper Reset | V_{DPOR} | — | — | 1.8 | V | With respect to DGND, $V_+ > 6.0\text{V}$ RAM retention voltage ($V_{\text{RAM}} < V_{\text{DBOR}}$) |
| V_+ Voltage to ensure Wiper Reset | V_{APOR} | — | — | 6.0 | V | With respect to V_- , $V_L = 0\text{V}$ RAM retention voltage ($V_{\text{RAM}} < V_{\text{BOR}}$) |
| Digital to Analog Level Shifter Operational Voltage | V_{LS} | — | — | 2.3 | V | V_L to V_- voltage. DGND = V_- |
| Power Rail Voltages during Power Up (Note 1) | V_{LPOR} | — | — | 5.5 | V | Digital Powers (V_L / DGND) up 1st: V_+ and V_- floating or as V_+ / V_- powers up (V_+ must be \geq to DGND) (Note 18) |
| | $V_{\text{+POR}}$ | — | — | 36 | V | Analog Powers (V_+ / V_-) up 1st: V_L and DGND floating or as V_L / DGND powers up (DGND must be between V_- and V_+) (Note 18) |
| V_L Rise Rate to ensure Power-on Reset | V_{LRR} | (Note 6) | | | V/ms | With respect to DGND |

Note 1 This specification by design.

Note 4 V_+ voltage is dependent on V_- voltage. The maximum delta voltage between V_+ and V_- is 36V. The digital logic DGND potential can be anywhere between V_+ and V_- , the V_L potential must be \geq DGND and $\leq V_+$.

Note 5 Minimum value determined by maximum V_- to V_+ potential equals 36V and minimum $V_L = 1.8\text{V}$ for operation. So $36\text{V} - 1.8\text{V} = 34.2\text{V}$.

Note 6 POR/BOR is not rate dependent.

Note 16 For specified analog performance, V_+ must be 20V or greater (unless otherwise noted).

Note 18 During the power up sequence, to ensure expected Analog POR operation, the two power systems (Analog and Digital) should have a common reference to ensure that the driven DGND voltage is not at a higher potential than the driven V_+ voltage.

AC/DC CHARACTERISTICS (CONTINUED)

| DC Characteristics | | Standard Operating Conditions (unless otherwise specified) Operating Temperature $-40^{\circ}\text{C} \leq T_A \leq +125^{\circ}\text{C}$ (extended) All parameters apply across the specified operating ranges unless noted. $V_+ = 10\text{V}$ to 36V (referenced to V_-); $V_+ = +5\text{V}$ to $+18\text{V}$ & $V_- = -5.0\text{V}$ to -18V (referenced to DGND $\rightarrow \pm 5\text{V}$ to $\pm 18\text{V}$), $V_L = +2.7\text{V}$ to 5.5V , $5\text{ k}\Omega$, $10\text{ k}\Omega$, $50\text{ k}\Omega$, $100\text{ k}\Omega$ devices. Typical specifications represent values for $V_L = 5.5\text{V}$, $T_A = +25^{\circ}\text{C}$. | | | | | |
|--|------------|--|----------------|-------|------------------|--|------------------|
| Parameters | Sym | Min | Typ | Max | Units | Conditions | |
| Delay after device exits the reset state ($V_L > V_{BOR}$) | T_{BORD} | — | 10 | 20 | μs | | |
| Supply Current (Note 7) | I_{DDD} | — | 45 | 300 | μA | Serial Interface Active, Write all 0's to Volatile Wiper 0 (address 0h) $V_L = 5.5\text{V}$, $\overline{\text{CS}} = V_{IL}$, $F_{SCK} = 5\text{ MHz}$, $V_- = \text{DGND}$ | |
| | | — | — | 7 | μA | Serial Interface Inactive, $V_L = 5.5\text{V}$, $\text{SCK} = V_{IH}$, $\overline{\text{CS}} = V_{IH}$, Wiper = 0, $V_- = \text{DGND}$ | |
| | I_{DDA} | — | — | 5 | μA | Current V_+ to V_- , $PxA = PxW$, $\text{DGND} = V_- + (V_+/2)$ | |
| Resistance ($\pm 20\%$) (Note 8) | R_{AB} | 4.0 | 5 | 6.0 | $\text{k}\Omega$ | -502 devices, $V_+/V_- = 10\text{V}$ to 36V | |
| | | 8.0 | 10 | 12.0 | $\text{k}\Omega$ | -103 devices, $V_+/V_- = 10\text{V}$ to 36V | |
| | | 40.0 | 50 | 60.0 | $\text{k}\Omega$ | -503 devices, $V_+/V_- = 10\text{V}$ to 36V | |
| | | 80.0 | 100 | 120.0 | $\text{k}\Omega$ | -104 devices, $V_+/V_- = 10\text{V}$ to 36V | |
| R_{AB} Current | I_{AB} | — | — | 9.00 | mA | -502 devices | |
| | | — | — | 4.50 | mA | -103 devices | |
| | | — | — | 0.90 | mA | -503 devices | |
| | | — | — | 0.45 | mA | -104 devices | |
| Resolution | N | 256 | | | Taps | 8-bit | No Missing Codes |
| | | 128 | | | Taps | 7-bit | No Missing Codes |
| Step Resistance (see Appendix B.4) | R_S | — | $R_{AB}/(255)$ | — | Ω | 8-bit | Note 1 |
| | | — | $R_{AB}/(127)$ | — | Ω | 7-bit | Note 1 |

Note 1 This specification by design.

Note 7 Supply current (I_{DDD} and I_{DDA}) is independent of current through the resistor network.

Note 8 Resistance (R_{AB}) is defined as the resistance between Terminal A to Terminal B.

Note 9 Guaranteed by the R_{AB} specification and Ohms Law.

MCP41HVX1

AC/DC CHARACTERISTICS (CONTINUED)

| DC Characteristics | | Standard Operating Conditions (unless otherwise specified) Operating Temperature $-40^{\circ}\text{C} \leq T_A \leq +125^{\circ}\text{C}$ (extended) All parameters apply across the specified operating ranges unless noted. $V_+ = 10\text{V}$ to 36V (referenced to V_-); $V_+ = +5\text{V}$ to $+18\text{V}$ & $V_- = -5.0\text{V}$ to -18V (referenced to DGND $\rightarrow \pm 5\text{V}$ to $\pm 18\text{V}$), $V_L = +2.7\text{V}$ to 5.5V , $5\text{ k}\Omega$, $10\text{ k}\Omega$, $50\text{ k}\Omega$, $100\text{ k}\Omega$ devices. Typical specifications represent values for $V_L = 5.5\text{V}$, $T_A = +25^{\circ}\text{C}$. | | | | | |
|---|--------------------------|--|-----|-------|-------------------------|---|--|
| Parameters | Sym | Min | Typ | Max | Units | Conditions | |
| Wiper Resistance (see Appendix B.5) | R_W | — | 75 | 170 | Ω | $I_W = 1\text{ mA}$ | $V_+ = +18\text{V}$, $V_- = -18\text{V}$, code = 00h, PxA = floating, PxB = V_- . |
| | | — | 145 | 200 | Ω | $I_W = 1\text{ mA}$ | $V_+ = +5.0\text{V}$, $V_- = -5.0\text{V}$, code = 00h, PxA = floating, PxB = V_- . (Note 2) |
| Nominal Resistance Tempco (see Appendix B.23) | $\Delta R_{AB}/\Delta T$ | — | 50 | — | ppm/ $^{\circ}\text{C}$ | $T_A = -40^{\circ}\text{C}$ to $+85^{\circ}\text{C}$ | |
| | | — | 100 | — | ppm/ $^{\circ}\text{C}$ | $T_A = -40^{\circ}\text{C}$ to $+125^{\circ}\text{C}$ | |
| Ratiometric Tempco (see Appendix B.22) | $\Delta V_{WB}/\Delta T$ | — | 15 | — | ppm/ $^{\circ}\text{C}$ | Code = Mid-scale (80h or 40h) | |
| Resistor Terminal Input Voltage Range (Terminals A, B and W) | V_A, V_W, V_B | V_- | — | V_+ | V | Note 1 , Note 11 | |
| Current through Terminals (A, B, and Wiper) (Note 1) | I_T, I_W | — | — | 25 | mA | -502 devices | $I_{BW(W \neq ZS)}$ and $I_{AW(W \neq FS)}$ |
| | | — | — | 12.5 | mA | -103 devices | $I_{BW(W \neq ZS)}$ and $I_{AW(W \neq FS)}$ |
| | | — | — | 6.5 | mA | -503 devices | $I_{BW(W \neq ZS)}$ and $I_{AW(W \neq FS)}$ |
| | | — | — | 6.5 | mA | -104 devices | $I_{BW(W \neq ZS)}$ and $I_{AW(W \neq FS)}$ |
| | | — | — | 36 | mA | $I_{BW(W = ZS)}$, or $I_{AW(W = FS)}$ | |
| Leakage current into A, W or B | I_{TL} | — | 5 | — | nA | A = W = B = V_- | |

[Note 1](#) This specification by design.

[Note 2](#) This parameter is not tested, but specified by characterization.

[Note 11](#) Resistor terminals A, W and B's polarity with respect to each other is not restricted.

AC/DC CHARACTERISTICS (CONTINUED)

| DC Characteristics | | Standard Operating Conditions (unless otherwise specified) | | | | | | |
|--|------------|---|-----|-------|-------|----------------|-------|--------------------------------------|
| | | Operating Temperature $-40^{\circ}\text{C} \leq T_A \leq +125^{\circ}\text{C}$ (extended) | | | | | | |
| | | All parameters apply across the specified operating ranges unless noted. | | | | | | |
| | | $V_+ = 10\text{V to } 36\text{V}$ (referenced to V_-); | | | | | | |
| | | $V_+ = +5\text{V to } +18\text{V}$ & $V_- = -5.0\text{V to } -18\text{V}$ (referenced to DGND $\rightarrow \pm 5\text{V to } \pm 18\text{V}$), | | | | | | |
| | | $V_L = +2.7\text{V to } 5.5\text{V}$, $5\text{ k}\Omega$, $10\text{ k}\Omega$, $50\text{ k}\Omega$, $100\text{ k}\Omega$ devices. | | | | | | |
| | | Typical specifications represent values for $V_L = 5.5\text{V}$, $T_A = +25^{\circ}\text{C}$. | | | | | | |
| Parameters | Sym | Min | Typ | Max | Units | Conditions | | |
| Full Scale Error (Potentiometer) (8-bit code = FFh, 7-bit code = 7Fh) (Note 10, Note 17) ($V_A = V_+$, $V_B = V_-$) (see Appendix B.10) | V_{WFSE} | -8.5 | — | — | LSb | 5 k Ω | 8-bit | $V_{AB} = 20\text{V to } 36\text{V}$ |
| | | -13.5 | — | — | LSb | | | $V_{AB} = 10\text{V to } 36\text{V}$ |
| | | -4.5 | — | — | LSb | | 7-bit | $V_{AB} = 20\text{V to } 36\text{V}$ |
| | | -7.0 | — | — | LSb | | | $V_{AB} = 10\text{V to } 36\text{V}$ |
| | | -4.5 | — | — | LSb | 10 k Ω | 8-bit | $V_{AB} = 20\text{V to } 36\text{V}$ |
| | | -6.0 | — | — | LSb | | | $V_{AB} = 10\text{V to } 36\text{V}$ |
| | | -2.25 | — | — | LSb | | 7-bit | $V_{AB} = 20\text{V to } 36\text{V}$ |
| | | -3.5 | — | — | LSb | | | $V_{AB} = 10\text{V to } 36\text{V}$ |
| | | -0.9 | — | — | LSb | 50 k Ω | 8-bit | $V_{AB} = 20\text{V to } 36\text{V}$ |
| | | -1.25 | — | — | LSb | | | $V_{AB} = 10\text{V to } 36\text{V}$ |
| | | -0.95 | — | — | LSb | | 7-bit | $V_{AB} = 20\text{V to } 36\text{V}$ |
| | | -1.1 | — | — | LSb | | | $V_{AB} = 10\text{V to } 36\text{V}$ |
| | | -0.5 | — | — | LSb | 100 k Ω | 8-bit | $V_{AB} = 20\text{V to } 36\text{V}$ |
| | | -0.7 | — | — | LSb | | | $V_{AB} = 10\text{V to } 36\text{V}$ |
| | | -0.75 | — | — | LSb | | 7-bit | $V_{AB} = 20\text{V to } 36\text{V}$ |
| | | -0.9 | — | — | LSb | | | $V_{AB} = 10\text{V to } 36\text{V}$ |
| Zero Scale Error (Potentiometer) (8-bit code = 00h, 7-bit code = 00h) (Note 10, Note 17) ($V_A = V_+$, $V_B = V_-$) (see Appendix B.11) | V_{WZSE} | — | — | +8.5 | LSb | 5 k Ω | 8-bit | $V_{AB} = 20\text{V to } 36\text{V}$ |
| | | — | — | +13.5 | LSb | | | $V_{AB} = 10\text{V to } 36\text{V}$ |
| | | — | — | +4.5 | LSb | | 7-bit | $V_{AB} = 20\text{V to } 36\text{V}$ |
| | | — | — | +7.0 | LSb | | | $V_{AB} = 10\text{V to } 36\text{V}$ |
| | | — | — | +4.0 | LSb | 10 k Ω | 8-bit | $V_{AB} = 20\text{V to } 36\text{V}$ |
| | | — | — | +6.0 | LSb | | | $V_{AB} = 10\text{V to } 36\text{V}$ |
| | | — | — | +2.0 | LSb | | 7-bit | $V_{AB} = 20\text{V to } 36\text{V}$ |
| | | — | — | +3.0 | LSb | | | $V_{AB} = 10\text{V to } 36\text{V}$ |
| | | — | — | +0.8 | LSb | 50 k Ω | 8-bit | $V_{AB} = 20\text{V to } 36\text{V}$ |
| | | — | — | +1.2 | LSb | | | $V_{AB} = 10\text{V to } 36\text{V}$ |
| | | — | — | +0.5 | LSb | | 7-bit | $V_{AB} = 20\text{V to } 36\text{V}$ |
| | | — | — | +0.7 | LSb | | | $V_{AB} = 10\text{V to } 36\text{V}$ |
| | | — | — | +0.5 | LSb | 100 k Ω | 8-bit | $V_{AB} = 20\text{V to } 36\text{V}$ |
| | | — | — | +0.7 | LSb | | | $V_{AB} = 10\text{V to } 36\text{V}$ |
| | | — | — | +0.25 | LSb | | 7-bit | $V_{AB} = 20\text{V to } 36\text{V}$ |
| | | — | — | +0.4 | LSb | | | $V_{AB} = 10\text{V to } 36\text{V}$ |

Note 10 Measured at V_W with $V_A = V_+$ and $V_B = V_-$.

Note 17 Analog switch leakage effects this specification. Higher temperatures increase the switch leakage.

MCP41HVX1

AC/DC CHARACTERISTICS (CONTINUED)

| DC Characteristics | | Standard Operating Conditions (unless otherwise specified) Operating Temperature $-40^{\circ}\text{C} \leq T_A \leq +125^{\circ}\text{C}$ (extended) All parameters apply across the specified operating ranges unless noted. $V_+ = 10\text{V}$ to 36V (referenced to V_-); $V_+ = +5\text{V}$ to $+18\text{V}$ & $V_- = -5.0\text{V}$ to -18V (referenced to DGND $\rightarrow \pm 5\text{V}$ to $\pm 18\text{V}$), $V_L = +2.7\text{V}$ to 5.5V , $5\text{ k}\Omega$, $10\text{ k}\Omega$, $50\text{ k}\Omega$, $100\text{ k}\Omega$ devices. Typical specifications represent values for $V_L = 5.5\text{V}$, $T_A = +25^{\circ}\text{C}$. | | | | | | |
|---|-------|--|-------------|--------|-------|----------------|--|--|
| Parameters | Sym | Min | Typ | Max | Units | Conditions | | |
| Potentiometer Integral Non-linearity (Note 10, Note 17) (see Appendix B.12) | P-INL | -1 | ± 0.5 | +1 | LSb | 5 k Ω | 8-bit | $V_{AB} = 10\text{V}$ to 36V |
| | | -0.5 | ± 0.25 | +0.5 | LSb | | 7-bit | $V_{AB} = 10\text{V}$ to 36V |
| | | -1 | ± 0.5 | +1 | LSb | 10 k Ω | 8-bit | $V_{AB} = 10\text{V}$ to 36V |
| | | -0.5 | ± 0.25 | +0.5 | LSb | | 7-bit | $V_{AB} = 10\text{V}$ to 36V |
| | | -1.1 | ± 0.5 | +1.1 | LSb | 50 k Ω | 8-bit | $V_{AB} = 10\text{V}$ to 36V |
| | | -1 | ± 0.5 | +1 | LSb | | | $V_{AB} = 20\text{V}$ to 36V , (Note 2) |
| | | -1 | ± 0.5 | +1 | LSb | | | $V_{AB} = 10\text{V}$ to 36V , $-40^{\circ}\text{C} \leq T_A \leq +85^{\circ}\text{C}$ (Note 2) |
| | | -0.6 | ± 0.25 | +0.6 | LSb | 100 k Ω | 7-bit | $V_{AB} = 10\text{V}$ to 36V |
| | | -1.85 | ± 0.5 | +1.85 | LSb | | 8-bit | $V_{AB} = 10\text{V}$ to 36V |
| | | -1.2 | ± 0.5 | +1.2 | LSb | | | $V_{AB} = 20\text{V}$ to 36V , (Note 2) |
| | | -1 | ± 0.5 | +1 | LSb | | $V_{AB} = 10\text{V}$ to 36V , $-40^{\circ}\text{C} \leq T_A \leq +85^{\circ}\text{C}$ (Note 2) | |
| | | -1 | ± 0.5 | +1 | LSb | 7-bit | $V_{AB} = 10\text{V}$ to 36V | |
| Potentiometer Differential Non-linearity (Note 10, Note 17) (see Appendix B.13) | P-DNL | -0.5 | ± 0.25 | +0.5 | LSb | 5 k Ω | 8-bit | $V_{AB} = 10\text{V}$ to 36V |
| | | -0.25 | ± 0.125 | +0.25 | LSb | | 7-bit | $V_{AB} = 10\text{V}$ to 36V |
| | | -0.25 | ± 0.125 | +0.25 | LSb | 10 k Ω | 8-bit | $V_{AB} = 10\text{V}$ to 36V |
| | | -0.125 | ± 0.1 | +0.125 | LSb | | 7-bit | $V_{AB} = 10\text{V}$ to 36V |
| | | -0.25 | ± 0.125 | +0.25 | LSb | 50 k Ω | 8-bit | $V_{AB} = 10\text{V}$ to 36V |
| | | -0.125 | ± 0.1 | +0.125 | LSb | | 7-bit | $V_{AB} = 10\text{V}$ to 36V |
| | | -0.25 | ± 0.125 | +0.25 | LSb | 100 k Ω | 8-bit | $V_{AB} = 10\text{V}$ to 36V |
| | | -0.125 | -0.15 | +0.125 | LSb | | 7-bit | $V_{AB} = 10\text{V}$ to 36V |

Note 2 This parameter is not tested, but specified by characterization.

Note 10 Measured at V_W with $V_A = V_+$ and $V_B = V_-$.

Note 17 Analog switch leakage effects this specification. Higher temperatures increase the switch leakage.

AC/DC CHARACTERISTICS (CONTINUED)

| DC Characteristics | | Standard Operating Conditions (unless otherwise specified) Operating Temperature $-40^{\circ}\text{C} \leq T_A \leq +125^{\circ}\text{C}$ (extended) All parameters apply across the specified operating ranges unless noted. $V_+ = 10\text{V}$ to 36V (referenced to V_-); $V_+ = +5\text{V}$ to $+18\text{V}$ & $V_- = -5.0\text{V}$ to -18V (referenced to DGND $\rightarrow \pm 5\text{V}$ to $\pm 18\text{V}$), $V_L = +2.7\text{V}$ to 5.5V , $5\text{ k}\Omega$, $10\text{ k}\Omega$, $50\text{ k}\Omega$, $100\text{ k}\Omega$ devices. Typical specifications represent values for $V_L = 5.5\text{V}$, $T_A = +25^{\circ}\text{C}$. | | | | | | |
|--|-------|--|-----|-----|---------------|----------------|--|------------|
| Parameters | Sym | Min | Typ | Max | Units | Conditions | | |
| Bandwidth -3 dB (load = 30 pF) | BW | — | 480 | — | kHz | 5 k Ω | 8-bit | Code = 7Fh |
| | | — | 480 | — | kHz | | 7-bit | Code = 3Fh |
| | | — | 240 | — | kHz | 10 k Ω | 8-bit | Code = 7Fh |
| | | — | 240 | — | kHz | | 7-bit | Code = 3Fh |
| | | — | 48 | — | kHz | 50 k Ω | 8-bit | Code = 7Fh |
| | | — | 48 | — | kHz | | 7-bit | Code = 3Fh |
| | | — | 24 | — | kHz | 100 k Ω | 8-bit | Code = 7Fh |
| | | — | 24 | — | kHz | | 7-bit | Code = 3Fh |
| V_W Settling Time ($V_A = 10\text{V}$, $V_B = 0\text{V}$, $\pm 1\text{LSb}$ error band, $C_L = 50\text{ pF}$) (see Appendix B.17) | t_S | — | 1 | — | μs | 5 k Ω | Code = 00h \rightarrow FFh (7Fh); FFh (7Fh) \rightarrow 00h | |
| | | — | 1 | — | μs | 10 k Ω | Code = 00h \rightarrow FFh (7Fh); FFh (7Fh) \rightarrow 00h | |
| | | — | 2.5 | — | μs | 50 k Ω | Code = 00h \rightarrow FFh (7Fh); FFh (7Fh) \rightarrow 00h | |
| | | — | 5 | — | μs | 100 k Ω | Code = 00h \rightarrow FFh (7Fh); FFh (7Fh) \rightarrow 00h | |

MCP41HVX1

AC/DC CHARACTERISTICS (CONTINUED)

| DC Characteristics | | Standard Operating Conditions (unless otherwise specified) | | | | | | | |
|---|-------|---|-------|-------|-------|--|-------|--|--|
| | | Operating Temperature $-40^{\circ}\text{C} \leq T_A \leq +125^{\circ}\text{C}$ (extended) | | | | | | | |
| | | All parameters apply across the specified operating ranges unless noted. | | | | | | | |
| | | $V_+ = 10\text{V to } 36\text{V}$ (referenced to V_-); | | | | | | | |
| | | $V_+ = +5\text{V to } +18\text{V}$ & $V_- = -5.0\text{V to } -18\text{V}$ (referenced to DGND $\rightarrow \pm 5\text{V to } \pm 18\text{V}$), | | | | | | | |
| | | $V_L = +2.7\text{V to } 5.5\text{V}$, 5 k Ω , 10 k Ω , 50 k Ω , 100 k Ω devices. | | | | | | | |
| | | Typical specifications represent values for $V_L = 5.5\text{V}$, $T_A = +25^{\circ}\text{C}$. | | | | | | | |
| Parameters | Sym | Min | Typ | Max | Units | Conditions | | | |
| Rheostat Integral Non-linearity (Note 12 , Note 13 , Note 14 , Note 17) (see Appendix B.5) | R-INL | -1.75 | — | +1.75 | LSb | 5 k Ω | 8-bit | $I_W = 6.0\text{ mA}$, $(V_+ - V_-) = 36\text{V}$ (Note 2) | |
| | | -2.5 | — | +2.5 | LSb | | | $I_W = 3.3\text{ mA}$, $(V_+ - V_-) = 20\text{V}$ (Note 2) | |
| | | -4.0 | — | +4.0 | LSb | | | $I_W = 1.7\text{ mA}$, $(V_+ - V_-) = 10\text{V}$ | |
| | | 7-bit | -1.0 | — | +1.0 | | LSb | $I_W = 6.0\text{ mA}$, $(V_+ - V_-) = 36\text{V}$ (Note 2) | |
| | | | -1.5 | — | +1.5 | | LSb | $I_W = 3.3\text{ mA}$, $(V_+ - V_-) = 20\text{V}$ (Note 2) | |
| | | | -2.0 | — | +2.0 | | LSb | $I_W = 1.7\text{ mA}$, $(V_+ - V_-) = 10\text{V}$ | |
| | | 10 k Ω | 8-bit | -1.0 | — | +1.0 | LSb | $I_W = 3.0\text{ mA}$, $(V_+ - V_-) = 36\text{V}$ (Note 2) | |
| | | | | -1.75 | — | +1.75 | LSb | $I_W = 1.7\text{ mA}$, $(V_+ - V_-) = 20\text{V}$ (Note 2) | |
| | | | | -2.0 | — | +2.0 | LSb | $I_W = 830\text{ }\mu\text{A}$, $(V_+ - V_-) = 10\text{V}$ | |
| | | | 7-bit | -0.5 | — | +0.5 | LSb | $I_W = 3.0\text{ mA}$, $(V_+ - V_-) = 36\text{V}$ (Note 2) | |
| | | | | -0.8 | — | +0.8 | LSb | $I_W = 1.7\text{ mA}$, $(V_+ - V_-) = 20\text{V}$ (Note 2) | |
| | | | | -1.0 | — | +1.0 | LSb | $I_W = 830\text{ }\mu\text{A}$, $(V_+ - V_-) = 10\text{V}$ | |
| | | 50 k Ω | 8-bit | -1.0 | — | +1.0 | LSb | $I_W = 600\text{ }\mu\text{A}$, $(V_+ - V_-) = 36\text{V}$ (Note 2) | |
| | | | | -1.0 | — | +1.0 | LSb | $I_W = 330\text{ }\mu\text{A}$, $(V_+ - V_-) = 20\text{V}$ (Note 2) | |
| | | | | -1.2 | — | +1.2 | LSb | $I_W = 170\text{ }\mu\text{A}$, $(V_+ - V_-) = 10\text{V}$ | |
| | | | 7-bit | -0.5 | — | +0.5 | LSb | $I_W = 600\text{ }\mu\text{A}$, $(V_+ - V_-) = 36\text{V}$ (Note 2) | |
| | | | | -0.5 | — | +0.5 | LSb | $I_W = 330\text{ }\mu\text{A}$, $(V_+ - V_-) = 20\text{V}$ (Note 2) | |
| | | | | -0.6 | — | +0.6 | LSb | $I_W = 170\text{ }\mu\text{A}$, $(V_+ - V_-) = 10\text{V}$ | |
| | | 100 k Ω | 8-bit | -1.0 | — | +1.0 | LSb | $I_W = 300\text{ }\mu\text{A}$, $(V_+ - V_-) = 36\text{V}$ (Note 2) | |
| | | | | -1.0 | — | +1.0 | LSb | $I_W = 170\text{ }\mu\text{A}$, $(V_+ - V_-) = 20\text{V}$ (Note 2) | |
| -1.2 | — | | | +1.2 | LSb | $I_W = 83\text{ }\mu\text{A}$, $(V_+ - V_-) = 10\text{V}$ | | | |
| 7-bit | -0.5 | | — | +0.5 | LSb | $I_W = 300\text{ }\mu\text{A}$, $(V_+ - V_-) = 36\text{V}$ (Note 2) | | | |
| | -0.5 | | — | +0.5 | LSb | $I_W = 170\text{ }\mu\text{A}$, $(V_+ - V_-) = 20\text{V}$ (Note 2) | | | |
| | -0.6 | | — | +0.6 | LSb | $I_W = 83\text{ }\mu\text{A}$, $(V_+ - V_-) = 10\text{V}$ | | | |

[Note 2](#) This parameter is not tested, but specified by characterization.

[Note 12](#) Non-linearity is affected by wiper resistance (R_W), which changes significantly over voltage and temperature.

[Note 13](#) Externally connected to a Rheostat configuration (RBW), and then tested.

[Note 14](#) Wiper current (I_W) condition determined by $R_{AB(\text{max})}$ and Voltage Condition, the delta voltage between V_+ and V_- (voltages are 36V, 20V, and 10V).

[Note 17](#) Analog switch leakage effects this specification. Higher temperatures increase the switch leakage.

AC/DC CHARACTERISTICS (CONTINUED)

| DC Characteristics | | Standard Operating Conditions (unless otherwise specified) Operating Temperature $-40^{\circ}\text{C} \leq T_A \leq +125^{\circ}\text{C}$ (extended) | | | | | |
|--|-------|--|-----|-------|-------|--|--|
| | | All parameters apply across the specified operating ranges unless noted. V+ = 10V to 36V (referenced to V-); V+ = +5V to +18V & V- = -5.0V to -18V (referenced to DGND -> $\pm 5\text{V}$ to $\pm 18\text{V}$), V _L = +2.7V to 5.5V, 5 k Ω , 10 k Ω , 50 k Ω , 100 k Ω devices. Typical specifications represent values for V _L = 5.5V, T _A = +25 $^{\circ}\text{C}$. | | | | | |
| Parameters | Sym | Min | Typ | Max | Units | Conditions | |
| Rheostat Differential Non-linearity (Note 12 , Note 13 , Note 14 , Note 17) (see Appendix B.5) | R-DNL | -0.5 | — | +0.5 | LSb | 5 k Ω 8-bit $I_W = 6.0 \text{ mA}$, (V+ - V-) = 36V (Note 2) | |
| | | -0.5 | — | +0.5 | LSb | | $I_W = 3.3 \text{ mA}$, (V+ - V-) = 20V (Note 2) |
| | | -0.6 | — | +0.6 | LSb | | $I_W = 1.7 \text{ mA}$, (V+ - V-) = 10V |
| | | -0.25 | — | +0.25 | LSb | 7-bit $I_W = 6.0 \text{ mA}$, (V+ - V-) = 36V (Note 2) | |
| | | -0.25 | — | +0.25 | LSb | | $I_W = 3.3 \text{ mA}$, (V+ - V-) = 20V (Note 2) |
| | | -0.3 | — | +0.3 | LSb | | $I_W = 1.7 \text{ mA}$, (V+ - V-) = 10V |
| | | -0.5 | — | +0.5 | LSb | 10 k Ω 8-bit $I_W = 3.0 \text{ mA}$, (V+ - V-) = 36V (Note 2) | |
| | | -0.5 | — | +0.5 | LSb | | $I_W = 1.7 \text{ mA}$, (V+ - V-) = 20V (Note 2) |
| | | -0.5 | — | +0.5 | LSb | | $I_W = 830 \mu\text{A}$, (V+ - V-) = 10V |
| | | -0.25 | — | +0.25 | LSb | 7-bit $I_W = 3.0 \text{ mA}$, (V+ - V-) = 36V (Note 2) | |
| | | -0.25 | — | +0.25 | LSb | | $I_W = 1.7 \text{ mA}$, (V+ - V-) = 20V (Note 2) |
| | | -0.25 | — | +0.25 | LSb | | $I_W = 830 \mu\text{A}$, (V+ - V-) = 10V |
| | | -0.5 | — | +0.5 | LSb | 50 k Ω 8-bit $I_W = 600 \mu\text{A}$, (V+ - V-) = 36V (Note 2) | |
| | | -0.5 | — | +0.5 | LSb | | $I_W = 330 \mu\text{A}$, (V+ - V-) = 20V (Note 2) |
| | | -0.5 | — | +0.5 | LSb | | $I_W = 170 \mu\text{A}$, (V+ - V-) = 10V |
| | | -0.25 | — | +0.25 | LSb | 7-bit $I_W = 600 \mu\text{A}$, (V+ - V-) = 36V (Note 2) | |
| | | -0.25 | — | +0.25 | LSb | | $I_W = 330 \mu\text{A}$, (V+ - V-) = 20V (Note 2) |
| | | -0.25 | — | +0.25 | LSb | | $I_W = 170 \mu\text{A}$, (V+ - V-) = 10V |
| | | -0.5 | — | +0.5 | LSb | 100 k Ω 8-bit $I_W = 300 \mu\text{A}$, (V+ - V-) = 36V (Note 2) | |
| | | -0.5 | — | +0.5 | LSb | | $I_W = 170 \mu\text{A}$, (V+ - V-) = 20V (Note 2) |
| | | -0.5 | — | +0.5 | LSb | | $I_W = 83 \mu\text{A}$, (V+ - V-) = 10V |
| | | -0.25 | — | +0.25 | LSb | 7-bit $I_W = 300 \mu\text{A}$, (V+ - V-) = 36V (Note 2) | |
| | | -0.25 | — | +0.25 | LSb | | $I_W = 170 \mu\text{A}$, (V+ - V-) = 20V (Note 2) |
| | | -0.25 | — | +0.25 | LSb | | $I_W = 83 \mu\text{A}$, (V+ - V-) = 10V |

[Note 2](#) This parameter is not tested, but specified by characterization.

[Note 12](#) Non-linearity is affected by wiper resistance (R_W), which changes significantly over voltage and temperature.

[Note 13](#) Externally connected to a Rheostat configuration (RBW), and then tested.

[Note 14](#) Wiper current (I_W) condition determined by $R_{AB(max)}$ and Voltage Condition, the delta voltage between V+ and V- (voltages are 36V, 20V, and 10V).

[Note 17](#) Analog switch leakage effects this specification. Higher temperatures increase the switch leakage.

MCP41HVX1

AC/DC CHARACTERISTICS (CONTINUED)

| DC Characteristics | | Standard Operating Conditions (unless otherwise specified) | | | | |
|---|-------------------------|---|-----------|---------------------|---------------|--|
| | | Operating Temperature $-40^{\circ}\text{C} \leq T_A \leq +125^{\circ}\text{C}$ (extended) | | | | |
| All parameters apply across the specified operating ranges unless noted. $V_+ = 10\text{V}$ to 36V (referenced to V_-); $V_+ = +5\text{V}$ to $+18\text{V}$ & $V_- = -5.0\text{V}$ to -18V (referenced to DGND $\rightarrow \pm 5\text{V}$ to $\pm 18\text{V}$), $V_L = +2.7\text{V}$ to 5.5V , $5\text{ k}\Omega$, $10\text{ k}\Omega$, $50\text{ k}\Omega$, $100\text{ k}\Omega$ devices. Typical specifications represent values for $V_L = 5.5\text{V}$, $T_A = +25^{\circ}\text{C}$. | | | | | | |
| Parameters | Sym | Min | Typ | Max | Units | Conditions |
| Capacitance (P_A) | C_A | — | 75 | — | pF | Measured to V_- , $f = 1\text{ MHz}$, Wiper code = Mid-Scale |
| Capacitance (P_W) | C_W | — | 120 | — | pF | Measured to V_- , $f = 1\text{ MHz}$, Wiper code = Mid-Scale |
| Capacitance (P_B) | C_B | — | 75 | — | pF | Measured to V_- , $f = 1\text{ MHz}$, Wiper code = Mid-Scale |
| Common-Mode Leakage | I_{CM} | — | 5 | — | nA | $V_A = V_B = V_W$ |
| Digital Interface Pin Capacitance | C_{IN} , C_{OUT} | — | 10 | — | pF | $f_C = 400\text{ kHz}$ |
| Digital Inputs/Outputs (\overline{CS} , \overline{SDI} , \overline{SDO} , \overline{SCK} , \overline{SHDN} , \overline{WLAT}) | | | | | | |
| Schmitt Trigger High-Input Threshold | V_{IH} | $0.45 V_L$ | — | $V_L + 0.3\text{V}$ | V | $2.7\text{V} \leq V_L \leq 5.5\text{V}$ |
| | | $0.5 V_L$ | — | $V_L + 0.3\text{V}$ | V | $1.8\text{V} \leq V_L \leq 2.7\text{V}$ |
| Schmitt Trigger Low-Input Threshold | V_{IL} | DGND - 0.5V | — | $0.2 V_L$ | V | |
| Hysteresis of Schmitt Trigger Inputs | V_{HYS} | — | $0.1 V_L$ | — | V | |
| Output Low Voltage (SDO) | V_{OL} | DGND | — | $0.2 V_L$ | V | $V_L = 5.5\text{V}$, $I_{OL} = 5\text{ mA}$ |
| | | DGND | — | $0.2 V_L$ | V | $V_L = 1.8\text{V}$, $I_{OL} = 800\text{ }\mu\text{A}$ |
| Output High Voltage (SDO) | V_{OH} | $0.8 V_L$ | — | V_L | V | $V_L = 5.5\text{V}$, $I_{OH} = -2.5\text{ mA}$ |
| | | $0.8 V_L$ | — | V_L | V | $V_L = 1.8\text{V}$, $I_{OL} = -800\text{ }\mu\text{A}$ |
| Input Leakage Current | I_{IL} | -1 | | 1 | μA | $V_{IN} = V_L$ and $V_{IN} = \text{DGND}$ |

AC/DC CHARACTERISTICS (CONTINUED)

| DC Characteristics | | Standard Operating Conditions (unless otherwise specified) Operating Temperature $-40^{\circ}\text{C} \leq T_A \leq +125^{\circ}\text{C}$ (extended) All parameters apply across the specified operating ranges unless noted. $V_+ = 10\text{V}$ to 36V (referenced to V_-); $V_+ = +5\text{V}$ to $+18\text{V}$ & $V_- = -5.0\text{V}$ to -18V (referenced to DGND $\rightarrow \pm 5\text{V}$ to $\pm 18\text{V}$), $V_L = +2.7\text{V}$ to 5.5V , $5\text{ k}\Omega$, $10\text{ k}\Omega$, $50\text{ k}\Omega$, $100\text{ k}\Omega$ devices. Typical specifications represent values for $V_L = 5.5\text{V}$, $T_A = +25^{\circ}\text{C}$. | | | | | |
|--|----------------------|--|--------|--------|-------|-------------------------|--|
| Parameters | Sym | Min | Typ | Max | Units | Conditions | |
| RAM (Wiper, TCON) Value | | | | | | | |
| Wiper Value Range | N | 0h | — | FFh | hex | 8-bit | |
| | | 0h | — | 7Fh | hex | 7-bit | |
| Wiper POR/BOR Value | $N_{\text{POR/BOR}}$ | 7Fh | | | hex | 8-bit | |
| | | 3Fh | | | hex | 7-bit | |
| TCON Value Range | N | 0h | — | FFh | hex | | |
| TCON POR/BOR Value | N_{TCON} | FF | | | hex | All Terminals connected | |
| Power Requirements | | | | | | | |
| Power Supply Sensitivity (see Appendix B.20) | PSS | — | 0.0015 | 0.0035 | %/% | 8-bit | $V_L = 2.7\text{V}$ to 5.5V , $V_+ = 18\text{V}$, $V_- = -18\text{V}$, Code = 7Fh |
| | | — | 0.0015 | 0.0035 | %/% | 7-bit | $V_L = 2.7\text{V}$ to 5.5V , $V_+ = 18\text{V}$, $V_- = -18\text{V}$, Code = 3Fh |
| Power Dissipation | P_{DISS} | — | 260 | — | mW | $5\text{ k}\Omega$ | $V_L = 5.5\text{V}$, $V_+ = 18\text{V}$, $V_- = -18\text{V}$ (Note 15) |
| | | — | 130 | — | mW | $10\text{ k}\Omega$ | |
| | | — | 26 | — | mW | $50\text{ k}\Omega$ | |
| | | — | 13 | — | mW | $100\text{ k}\Omega$ | |

Note 15 $P_{\text{DISS}} = I * V$, or $(I_{\text{DD}} * 5.5\text{V}) + (I_{\text{DDA}} * 36\text{V}) + (I_{\text{AB}} * 36\text{V})$.

MCP41HVX1

AC / DC Notes:

1. This specification by design.
2. This parameter is not tested, but specified by characterization.
3. See Absolute Maximum Ratings.
4. V+ voltage is dependent on V- voltage. The maximum delta voltage between V+ and V- is 36V. The digital logic DGND potential can be anywhere between V+ and V-, the V_L potential must be \geq DGND and \leq V+.
5. Minimum value determined by maximum V- to V+ potential equals 36V and minimum $V_L = 1.8V$ for operation. So $36V - 1.8V = 34.2V$.
6. POR/BOR is not rate dependent.
7. Supply current (I_{DDD} and I_{DDA}) is independent of current through the resistor network.
8. Resistance (R_{AB}) is defined as the resistance between Terminal A to Terminal B.
9. Guaranteed by the R_{AB} specification and Ohms Law.
10. Measured at V_W with $V_A = V+$ and $V_B = V-$.
11. Resistor terminals A, W and B's polarity with respect to each other is not restricted.
12. Non-linearity is affected by wiper resistance (R_W), which changes significantly over voltage and temperature.
13. Externally connected to a Rheostat configuration (R_{BW}), and then tested.
14. Wiper current (I_W) condition determined by $R_{AB(max)}$ and Voltage Condition, the delta voltage between V+ and V- (voltages are 36V, 20V, and 10V).
15. $P_{DISS} = I * V$, or $(I_{DDD} * 5.5V) + (I_{DDA} * 36V) + (I_{AB} * 36V)$.
16. For specified analog performance, V+ must be 20V or greater (unless otherwise noted).
17. Analog switch leakage effects this specification. Higher temperatures increase the switch leakage.
18. During the power up sequence, to ensure expected Analog POR operation, the two power systems (Analog and Digital) should have a common reference to ensure that the driven DGND voltage is not at a higher potential than the driven V+ voltage.

1.1 SPI Mode Timing Waveforms and Requirements



FIGURE 1-1: Settling Time Waveforms.

TABLE 1-1: WIPER SETTling TIMING

| Timing Characteristics | | Standard Operating Conditions (unless otherwise specified) | | | | | |
|--|-------|---|-----|-----|---------------|----------------|--|
| | | Operating Temperature $-40^{\circ}\text{C} \leq T_A \leq +125^{\circ}\text{C}$ (extended) | | | | | |
| | | All parameters apply across the specified operating ranges unless noted. | | | | | |
| | | $V_+ = 10\text{V to } 36\text{V}$ (referenced to V_-); | | | | | |
| | | $V_+ = +5\text{V to } +18\text{V}$ & $V_- = -5.0\text{V to } -18\text{V}$ (referenced to DGND $\rightarrow \pm 5\text{V to } \pm 18\text{V}$), | | | | | |
| | | $V_L = +2.7\text{V to } 5.5\text{V}$, 5 k Ω , 10 k Ω , 50 k Ω , 100 k Ω devices. | | | | | |
| | | Typical specifications represent values for $V_L = 5.5\text{V}$, $T_A = +25^{\circ}\text{C}$. | | | | | |
| Parameters | Sym | Min | Typ | Max | Units | Conditions | |
| V_W Settling Time ($V_A = 10\text{V}$, $V_B = 0\text{V}$, $\pm 1\text{LSb}$ error band, $C_L = 50\text{ pF}$) | t_S | — | 1 | — | μs | 5 k Ω | Code = 00h \rightarrow FFh (7Fh); FFh (7Fh) \rightarrow 00h |
| | | — | 1 | — | μs | 10 k Ω | Code = 00h \rightarrow FFh (7Fh); FFh (7Fh) \rightarrow 00h |
| | | — | 2.5 | — | μs | 50 k Ω | Code = 00h \rightarrow FFh (7Fh); FFh (7Fh) \rightarrow 00h |
| | | — | 5 | — | μs | 100 k Ω | Code = 00h \rightarrow FFh (7Fh); FFh (7Fh) \rightarrow 00h |



FIGURE 1-2: SPI Timing Waveform (Mode = 11).

MCP41HVX1

TABLE 1-2: SPI REQUIREMENTS (MODE = 11)

| # | Characteristic | Symbol | Min | Max | Units | Conditions |
|-----|---|-----------------|-----|-----|-------|------------------------|
| | SCK Input Frequency | F_{SCK} | — | 10 | MHz | $V_L = 2.7V$ to $5.5V$ |
| | | | — | 1 | MHz | $V_L = 1.8V$ to $2.7V$ |
| 70a | \overline{CS} Active (V_{IL}) to SCK \uparrow input | $T_{csA2scH}$ | 25 | — | ns | |
| 70b | \overline{WLAT} Active (V_{IL}) to eighth (or sixteenth) SCK \downarrow of the Serial Command to ensure previous data is latched (setup time) | $T_{wIA2scH}$ | 20 | — | ns | |
| 71 | SCK input high time | T_{scH} | 35 | — | ns | $V_L = 2.7V$ to $5.5V$ |
| | | | 120 | — | ns | $V_L = 1.8V$ to $2.7V$ |
| 72 | SCK input low time | T_{scL} | 35 | — | ns | $V_L = 2.7V$ to $5.5V$ |
| | | | 120 | — | ns | $V_L = 1.8V$ to $2.7V$ |
| 73 | Setup time of SDI input to SCK \uparrow edge | $T_{DIv2scH}$ | 10 | — | ns | |
| 74 | Hold time of SDI input from SCK \uparrow edge | T_{scH2DI} | 20 | — | ns | |
| 77 | \overline{CS} Inactive (V_{IH}) to SDO output high-impedance | $T_{csH2DoZ}$ | — | 50 | ns | Note 1 |
| 80 | SDO data output valid after SCK \downarrow edge | $T_{scL2DoV}$ | — | 55 | ns | $V_L = 2.7V$ to $5.5V$ |
| | | | — | 90 | ns | $V_L = 1.8V$ to $2.7V$ |
| 83a | \overline{CS} Inactive (V_{IH}) after SCK \uparrow edge | $T_{scH2csI}$ | 100 | — | ns | |
| 83b | \overline{WLAT} Inactive (V_{IH}) after eighth (or sixteenth) SCK \downarrow edge (hold time) | $T_{scH2wlatI}$ | 50 | — | ns | |
| 84 | Hold time of \overline{CS} (or \overline{WLAT}) Inactive (V_{IH}) to \overline{CS} (or \overline{WLAT}) Active (V_{IL}) | $T_{csA2csI}$ | 20 | — | ns | |
| 85 | \overline{WLAT} input low time | T_{wLATL} | 25 | — | ns | |

Note 1: This specification by design.



FIGURE 1-3: SPI Timing Waveform (Mode = 00).

TABLE 1-3: SPI REQUIREMENTS (MODE = 00)

| # | Characteristic | Symbol | Min | Max | Units | Conditions |
|-----|---|-------------|-----|-----|-------|------------------------|
| | SCK Input Frequency | F_{SCK} | — | 10 | MHz | $V_L = 2.7V$ to $5.5V$ |
| | | | — | 1 | MHz | $V_L = 1.8V$ to $2.7V$ |
| 70a | \overline{CS} Active (V_{IL}) to SCK \uparrow input | TcsA2sch | 25 | — | ns | |
| 70b | \overline{WLAT} Active (V_{IL}) to eighth (or sixteenth) SCK \downarrow of the Serial Command to ensure previous data is latched (setup time) | TwIA2sch | 20 | — | ns | |
| 71 | SCK input high time | Tsch | 35 | — | ns | $V_L = 2.7V$ to $5.5V$ |
| | | | 120 | — | ns | $V_L = 1.8V$ to $2.7V$ |
| 72 | SCK input low time | TscL | 35 | — | ns | $V_L = 2.7V$ to $5.5V$ |
| | | | 120 | — | ns | $V_L = 1.8V$ to $2.7V$ |
| 73 | Setup time of SDI input to SCK \uparrow edge | TdIV2sch | 10 | — | ns | |
| 74 | Hold time of SDI input from SCK \uparrow edge | Tsch2dIL | 20 | — | ns | |
| 77 | \overline{CS} Inactive (V_{IH}) to SDO output high-impedance | TcsH2doZ | — | 50 | ns | Note 1 |
| 80 | SDO data output valid after SCK \downarrow edge | TscL2doV | — | 55 | ns | $V_L = 2.7V$ to $5.5V$ |
| | | | — | 90 | ns | $V_L = 1.8V$ to $2.7V$ |
| 82 | SDO data output valid after \overline{CS} Active (V_{IL}) | TssL2doV | — | 70 | ns | |
| 83a | \overline{CS} Inactive (V_{IH}) after SCK \downarrow edge | TscL2csl | 100 | — | ns | |
| 83b | \overline{WLAT} Inactive (V_{IH}) after SCK \downarrow edge | TscL2wlatl | 50 | — | ns | |
| 84 | Hold time of \overline{CS} (or \overline{WLAT}) Inactive (V_{IH}) to \overline{CS} (or \overline{WLAT}) Active (V_{IL}) | TcsA2csl | 20 | — | ns | |
| 85 | \overline{WLAT} input low time | T_{WLATL} | 25 | — | ns | |

Note 1: This specification by design.

MCP41HVX1

TEMPERATURE CHARACTERISTICS

| Electrical Specifications: Unless otherwise indicated, $V_{DD} = +2.7V$ to $+5.5V$, $V_{SS} = GND$. | | | | | | |
|---|---------------|-----|------|------|-------|------------|
| Parameters | Sym | Min | Typ | Max | Units | Conditions |
| Temperature Ranges | | | | | | |
| Specified Temperature Range | T_A | -40 | — | +125 | °C | |
| Operating Temperature Range | T_A | -40 | — | +125 | °C | |
| Storage Temperature Range | T_A | -65 | — | +150 | °C | |
| Thermal Package Resistances | | | | | | |
| Thermal Resistance, 14L-TSSOP (ST) | θ_{JA} | — | 100 | — | °C/W | |
| Thermal Resistance, 20L-QFN (MQ) | θ_{JA} | — | 36.1 | — | °C/W | |

2.0 TYPICAL PERFORMANCE CURVES

Note: The device Performance Curves are available in a separate document. This is done to keep the file size of this PDF document less than the 10MB file attachment limit of many mail servers. The MCP41HVX1 Performance Curves document is literature number DS20005209, and can be found on the Microchip website. Look at the MCP41HVX1 Product Page under Documentation and Software, in the Data Sheets category.

MCP41HVX1

NOTES:

3.0 PIN DESCRIPTIONS

The descriptions of the pins are listed in [Table 3-1](#). Additional descriptions of the device pins follows.

TABLE 3-1: PINOUT DESCRIPTION FOR THE MCP41HVX1

| | | Pin | | | Function |
|-------|--------------------------|-------------------|------|-------------|---|
| TSSOP | QFN | Symbol | Type | Buffer Type | |
| 14L | 20L | | | | |
| 1 | 1 | V_L | P | — | Positive Digital Power Supply Input |
| 2 | 2 | SCK | I | ST | SPI Serial Clock pin |
| 3 | 3 | \overline{CS} | I | ST | Chip Select |
| 4 | 4 | SDI | I | ST | SPI Serial Data In pin |
| 5 | 5 | SDO | O | — | SPI Serial Data Out |
| 6 | 6 | \overline{WLAT} | I | ST | Wiper Latch Enable 0 = Received SPI Shift Register Buffer (SPIBUF) value is transferred to Wiper register. 1 = Received SPI data value is held in SPI Shift Register Buffer (SPIBUF). |
| 7 | 7 | \overline{SHDN} | I | ST | Shutdown |
| 8 | 11 | DGND | P | — | Ground |
| 9 | 8, 9, 10, 17, 18, 19, 20 | NC | — | — | Pin not internally connected to die. To reduce noise coupling, connect pin either to DGND or V_L . |
| 10 | 12 | V- | P | — | Analog Negative Potential Supply |
| 11 | 13 | P0B | I/O | A | Potentiometer 0 Terminal B |
| 12 | 14 | P0W | I/O | A | Potentiometer 0 Wiper Terminal |
| 13 | 15 | P0A | I/O | A | Potentiometer 0 Terminal A |
| 14 | 16 | V+ | P | — | Analog Positive Potential Supply |
| — | 21 | EP | P | — | Exposed Pad, connect to V- signal or Not Connected (floating). (Note 1) |

Legend: A = Analog ST = Schmitt Trigger
I = Input O = Output I/O = Input/Output P = Power

Note 1: The QFN package has a contact on the bottom of the package. This contact is conductively connected to the die substrate, and therefore should be unconnected or connected to the same ground as the device's V- pin.

MCP41HVX1

3.1 Positive Power Supply Input (V_L)

The V_L pin is the device's positive power supply input. The input power supply is relative to DGND and can range from 1.8V to 5.5V. A de-coupling capacitor on V_L (to DGND) is recommended to achieve maximum performance.

While the device's $V_L < V_{\min}$ (2.7V), the electrical performance of the device may not meet the data sheet specifications.

3.2 Serial Clock (SCK)

The SCK pin is the serial interface's Serial Clock pin. This pin is connected to the host controllers SCK pin. The MCP41HVX1 is an SPI slave device, so its SCK pin is an input only pin.

3.3 Chip Select (\overline{CS})

The \overline{CS} pin is the serial interface's chip select input. Forcing the \overline{CS} pin to V_{IL} enables the serial commands.

3.4 Serial Data In (SDI)

The SDI pin is the serial interfaces Serial Data In pin. This pin is connected to the host controller's SDO pin.

3.5 Serial Data Out (SDO)

The SDO pin is the serial interface's Serial Data Out pin. This pin is connected to the host controller's SDI pin.

This pin allows the host controller to read the digital potentiometer registers (Wiper and TCON), or monitor the state of the command error bit.

3.6 Wiper Latch (\overline{WLAT})

The \overline{WLAT} pin is used to hold off the transfer of the received wiper value (in the shift register) to the wiper register. This allows this transfer to be synchronized to an external event (such as zero crossing).

3.7 Shutdown (\overline{SHDN})

The \overline{SHDN} pin is used to force the resistor network terminals into the hardware shutdown state.

3.8 Digital Ground (DGND)

The DGND pin is the device's Digital ground reference.

3.9 Not Connected (NC)

This pin is not internally connected to the die. To reduce noise coupling, these pins should be connected to either V_L or DGND.

3.10 Analog Negative Voltage (V-)

Analog circuitry negative supply voltage. Must **not** have a higher potential than the DGND pin.

3.11 Potentiometer Terminal B

The terminal B pin is connected to the internal potentiometer's terminal B.

The potentiometer's terminal B is the fixed connection to the zero scale wiper value of the digital potentiometer. This corresponds to a wiper value of 0x00 for both 7-bit and 8-bit devices.

The terminal B pin does not have a polarity relative to the terminal W or A pins. The terminal B pin can support both positive and negative current. The voltage on terminal B must be between $V+$ and $V-$.

3.12 Potentiometer Wiper (W) Terminal

The terminal W pin is connected to the internal potentiometer's terminal W (the Wiper). The wiper terminal is the adjustable terminal of the digital potentiometer. The terminal W pin does not have a polarity relative to terminal's A or B pins. The terminal W pin can support both positive and negative current. The voltage on terminal W must be between $V+$ and $V-$.

If the $V+$ voltage powers up before the V_L voltage, the Wiper is forced to midscale once the Analog POR voltage is crossed.

If the $V+$ voltage powers up after the V_L voltage is greater than the Digital POR voltage, the Wiper is forced to the value in the Wiper Register once the Analog POR voltage is crossed.

3.13 Potentiometer Terminal A

The terminal A pin is connected to the internal potentiometer's terminal A.

The potentiometer's terminal A is the fixed connection to the full scale wiper value of the digital potentiometer. This corresponds to a wiper value of 0xFF for 8-bit devices or 0x7F for 7-bit devices.

The terminal A pin does not have a polarity relative to the terminal W or B pins. The terminal A pin can support both positive and negative current. The voltage on terminal A must be between $V+$ and $V-$.

3.14 Analog Positive Voltage (V+)

Analog circuitry positive supply voltage. Must have a higher potential than the $V-$ pin.

3.15 Exposed Pad (EP)

This pad is only on the bottom of the QFN packages. This pad is conductively connect to the device substrate. The EP pin must be connected to the $V-$ signal or left floating. This pad could be connected to a PCB heat sink to assist as a heat sink for the device.

4.0 FUNCTIONAL OVERVIEW

This data sheet covers a family of two volatile Digital Potentiometer devices that will be referred to as MCP41HVX1.

As the [Device Block Diagram](#) shows, there are six main functional blocks. These are:

- [Operating Voltage Range](#)
- [POR/BOR Operation](#)
- [Memory Map](#)
- [Control Module](#)
- [Resistor Network](#)
- [Serial Interface \(SPI\)](#)

The POR/BOR operation and the Memory Map are discussed in this section and the Resistor Network and SPI operation are described in their own sections. The [Device Commands](#) are discussed in [Section 7.0](#).

4.1 Operating Voltage Range

The MCP41HVX1 devices have four voltage signals. These are:

- V+ - Analog Power
- V_L - Digital Power
- DGND - Digital Ground
- V- - Analog Ground

[Figure 4-1](#) shows the two possible power-up sequences; analog power rails power-up first, or digital power rails power-up first. The device has been designed so that either power rail may power-up first. The device has a POR circuit for both Digital power circuitry and Analog power circuitry.

If the V+ voltage powers-up before the V_L voltage, the Wiper is forced to midscale once the Analog POR voltage is crossed.

If the V+ voltage powers-up after the V_L voltage is greater than the Digital POR voltage, the Wiper is forced to the value in the Wiper Register, once the Analog POR voltage is crossed.

[Figure 4-2](#) shows the three cases of the digital power signals (V_L / DGND) with respect to the analog power signals (V+ / V-). The device implement level shifts between the digital and analog power systems, which allows the digital interface voltage to be anywhere in the V+ / V- voltage window.

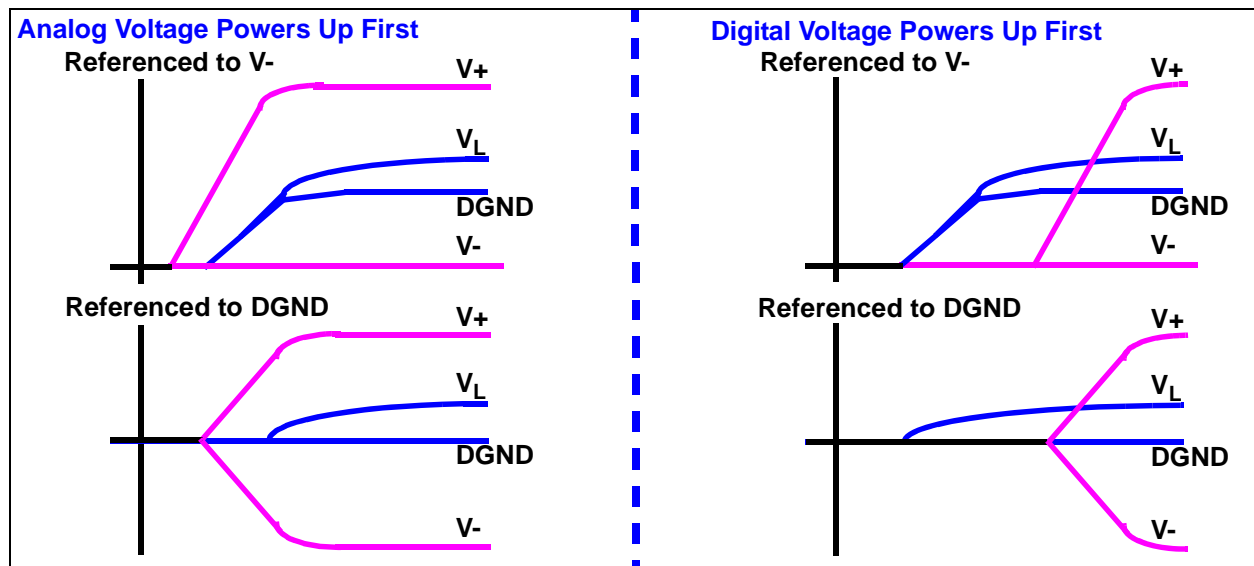

FIGURE 4-1: Power-On Sequences.

MCP41HVX1

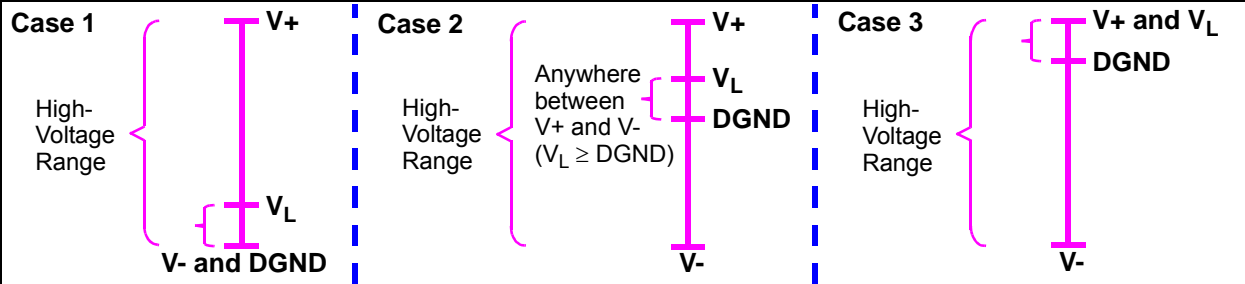

FIGURE 4-2: Voltage Ranges.

4.2 POR/BOR Operation

The resistor network's devices are powered by the analog power signals ($V+$ / $V-$), but the digital logic (including the wiper registers) is powered by the digital power signals (V_L / DGND). So, both the digital circuitry and analog circuitry have independent POR/BOR circuits.

The wiper position will be forced to the default state when the $V+$ voltage (relative to $V-$) is above the analog POR/BOR trip point. The wiper register will be in the default state when the V_L voltage (relative to DGND) is above the digital POR/BOR trip point.

The digital-signal-to-analog-signal voltage level shifters require a minimum voltage between the V_L and $V-$ signals. This voltage requirement is below the operating supply voltage specifications. The wiper output may fluctuate while the V_L voltage is less than the level shifter operating voltage, since the analog values may not reflect the digital value. Output issues may be reduced by powering-up the digital supply voltages to their operating voltage, before powering the analog supply voltage.

4.2.1 POWER-ON RESET

Each power system has its own independent Power-on-Reset circuitry. This is done so that regardless of the power-up sequencing of the analog and digital power rails, the wiper output will be forced to a default value after minimum conditions are met for either power supply.

Table 4-1 shows the interaction between the analog and digital PORs for the $V+$ and V_L voltages on the wiper pin state.

TABLE 4-1: WIPER PIN STATE BASED ON POR CONDITIONS

| V_L Voltage | $V+$ Voltage | | Comments |
|---------------------|-----------------|--------------------------|-------------------------------|
| | $V+ < V_{APOR}$ | $V+ \geq V_{APOR}$ | |
| $V_L < V_{DPOR}$ | Unknown | Mid-Scale | |
| $V_L \geq V_{DPOR}$ | Unknown | Wiper Register Value (1) | Wiper Register can be updated |

Note 1: Default POR state of the Wiper Register value is the Mid-Scale value.

4.2.1.1 Digital Circuitry

The Digital Power-on Reset (DPOR) is the case where the device's V_L signal has power applied (referenced from DGND) and the voltage rises above the trip point. The Brown-out Reset (BOR) occurs when a device had power applied to it, and the voltage drops below the trip point.

The device's RAM retention voltage (V_{RAM}) is lower than the POR/BOR voltage trip point (V_{POR}/V_{BOR}). The maximum V_{POR}/V_{BOR} voltage is less than 1.8V.

When the device powers up, the device V_L will cross the V_{POR}/V_{BOR} voltage. Once the V_L voltage crosses the V_{POR}/V_{BOR} voltage, the following happens:

- Volatile wiper registers are loaded with the POR/BOR value
- The TCON registers are loaded with the default values
- The device is capable of digital operation

Table 4-2 shows the default POR/BOR Wiper Register Setting Selection.

When $V_{POR}/V_{BOR} < V_{DD} < 2.7V$, the electrical performance may not meet the data sheet specifications. In this region, the device is capable of incrementing, decrementing, reading and writing to its volatile memory if the proper serial command is executed.

TABLE 4-2: DEFAULT POR/BOR WIPER REGISTER SETTING (DIGITAL)

| Typical R_{AB} Value | Package Code | Default POR Wiper Register Setting | Device Resolution | Wiper Code |
|------------------------|--------------|------------------------------------|-------------------|------------|
| 5.0 k Ω | -502 | Mid-scale | 8-bit | 7Fh |
| | | | 7-bit | 3Fh |
| 10.0 k Ω | -103 | Mid-scale | 8-bit | 7Fh |
| | | | 7-bit | 3Fh |
| 50.0 k Ω | -503 | Mid-scale | 8-bit | 7Fh |
| | | | 7-bit | 3Fh |
| 100.0 k Ω | -104 | Mid-scale | 8-bit | 7Fh |
| | | | 7-bit | 3Fh |

Note 1: Register setting independent of Analog power voltage.

MCP41HVX1

4.2.1.2 Analog Circuitry

The Analog Power-on Reset (APOR) is the case where the device's V+ pin voltage has power applied (referenced from V-) and the V+ pin voltage rises above the trip point.

Once the V_L pin voltage exceeds the digital POR trip point voltage, the Wiper Register will control the wiper setting.

Table 4-3 shows the default POR/BOR Wiper Setting for when the V_L pin is not powered (< digital POR trip point).

TABLE 4-3: DEFAULT POR/BOR WIPER SETTING (ANALOG)

| Typical R _{AB} Value | Package Code | Default POR Wiper Setting | Device Resolution |
|-------------------------------|--------------|---------------------------|-------------------|
| 5.0 kΩ | -502 | Mid-scale | 8-bit |
| | | | 7-bit |
| 10.0 kΩ | -103 | Mid-scale | 8-bit |
| | | | 7-bit |
| 50.0 kΩ | -503 | Mid-scale | 8-bit |
| | | | 7-bit |
| 100.0 kΩ | -104 | Mid-scale | 8-bit |
| | | | 7-bit |

Note 1: Wiper setting is dependent on the Wiper Register value if the V_L voltage is greater than the digital POR voltage.



FIGURE 4-3: DGND, V_L, V+, and V- Signal Waveform Examples.

4.2.2 BROWN-OUT RESET

Each power system has its own independent Brown-Out-Reset circuitry. This is done so that regardless of the power-down sequencing of the analog and digital power rails, the wiper output will be forced to a default value after the low voltage conditions are met for either power supply.

Table 4-4 shows the interaction between the analog and digital BORs for the V_+ and V_L voltages on the wiper pin state.

TABLE 4-4: WIPER PIN STATE BASED ON BOR CONDITIONS

| V_L Voltage | V_+ Voltage | | Comments |
|---------------------|------------------|--------------------------|-------------------------------|
| | $V_+ < V_{ABOR}$ | $V_+ \geq V_{ABOR}$ | |
| $V_L < V_{DBOR}$ | Unknown | Mid-Scale | |
| $V_L \geq V_{DBOR}$ | Unknown | Wiper Register Value (1) | Wiper Register can be updated |

Note 1: Default POR state of the Wiper Register value is the Mid-Scale value.

4.2.2.1 Digital Circuitry

When the device's digital power supply powers down, the device V_L pin voltage will cross the digital V_{DPOR}/V_{DBOR} voltage.

Once the V_L voltage decreases below the V_{DPOR}/V_{DBOR} voltage, the following happens:

- Serial Interface is disabled

If the V_L voltage decreases below the V_{RAM} voltage the following happens:

- Volatile wiper registers may become corrupted
- TCON registers may become corrupted

Section 4.2.1, **Power-on Reset** describes what occurs as the voltage recovers above the V_{DPOR}/V_{DBOR} voltage.

Serial commands not completed due to a brown-out condition may cause the memory location to become corrupted.

The brown-out circuit establishes a minimum V_{DBOR} threshold for operation ($V_{DBOR} < 1.8V$). The digital BOR voltage (V_{DBOR}) is higher than the RAM retention voltage (V_{RAM}) so that as the device voltage crosses the digital BOR threshold, the value that is loaded into the volatile wiper register is not corrupted, due to RAM retention issues.

When $V_L < V_{DBOR}$, all communications are ignored and potentiometer terminals are forced to the analog BOR state.

Whenever V_L transitions from $V_L < V_{DBOR}$ to $V_L > V_{DBOR}$, (a POR event) the Wiper's POR/BOR value is latched into the Wiper Register and the volatile TCON register is forced to the POR/BOR state.

When $1.8V \leq V_L$, the device is capable of digital operation.

Table 4-5 shows the digital potentiometer's level of functionality across the entire V_L range, while Figure 4-4 illustrates the Power-up and Brown-out functionality.

4.2.2.2 Analog Circuitry

The Analog Brown-Out-Reset (ABOR) is the case where the device's V_+ pin has power applied (referenced from V_-) and the V_+ pin voltage drops below the trip point. In this case, the resistor network terminals pins can become an unknown state.

MCP41HVX1

TABLE 4-5: DEVICE FUNCTIONALITY AT EACH V_L REGION

| V_L Level | $V+$ / $V-$ Level | Serial Interface | Potentiometer Terminals (2) | Wiper | | Comment |
|----------------------------|-------------------|------------------|-----------------------------|--|------------|---|
| | | | | Register Setting | Output (2) | |
| $V_L < V_{DBOR} < 1.8V$ | Valid Range | Ignored | "unknown" | Unknown | Invalid | |
| | Invalid Range | Ignored | "unknown" | Unknown | Invalid | |
| $V_{DBOR} \leq V_L < 1.8V$ | Valid Range | "Unknown" | connected | Volatile wiper Register initialized | Valid | The volatile registers are forced to the POR/BOR state when V_L transitions above the V_{DPOR} trip point |
| | Invalid Range | "Unknown" | connected | | Invalid | |
| $1.8V \leq V_L \leq 5.5V$ | Valid Range | Accepted | connected | Volatile wiper Register determines Wiper Setting | Valid | |
| | Invalid Range | Accepted | connected | | Invalid | |

Note 1: For system voltages below the minimum operating voltage, it is recommended to use a voltage supervisor to hold the system in reset. This ensures that MCP41HVX1 commands are not attempted out of the operating range of the device.

2: Assumes that $V+ > V_{APOR}$.

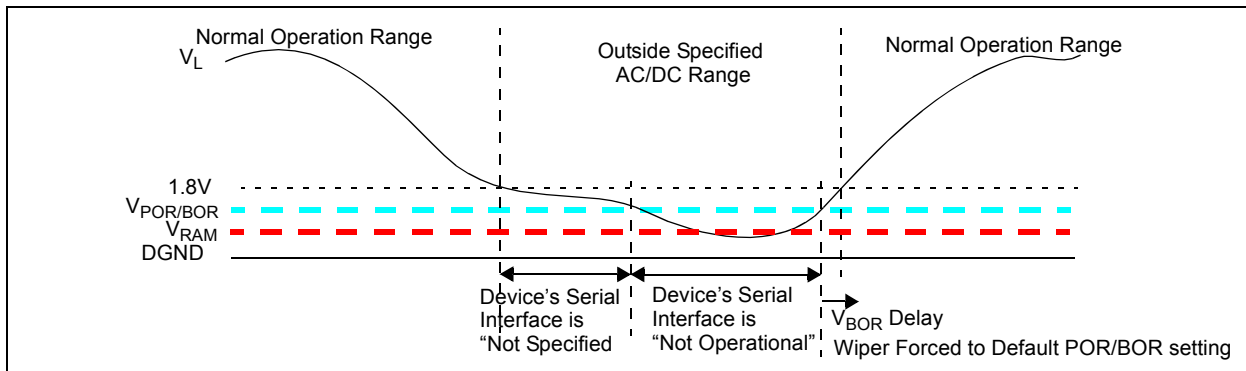

FIGURE 4-4: Power-up and Brown out - $V+$ / $V-$ at Normal Operating Voltage.

4.3 Control Module

The control module controls the following functionality:

- **Shutdown**
- **Wiper Latch**

4.3.1 SHUTDOWN

The MCP41HVX1 has two methods to disconnect the terminal's pins (P0A, P0W, and P0B) from the resistor network. These are:

- Hardware Shutdown pin ($\overline{\text{SHDN}}$)
- Terminal Control Register (TCON)

4.3.1.1 Hardware Shutdown Pin Operation

The $\overline{\text{SHDN}}$ pin has the same functionality as Microchip's family of standard voltage devices. When the $\overline{\text{SHDN}}$ pin is low, the P0A terminal will disconnect (become open) while the P0W terminal simultaneously connect to the P0B terminal (see [Figure 4-5](#)).

Note: When the $\overline{\text{SHDN}}$ pin is Active (V_{IL}), the state of the TCON register bits is overridden (ignored). When the state of the $\overline{\text{SHDN}}$ pin returns to the Inactive state (V_{IH}), the TCON register bits return to controlling the terminal connection state. That is the value in the TCON register is not corrupted

The Hardware Shutdown pin mode does not corrupt the Volatile Wiper Register. So when Shutdown is exited, the device returns to the Wiper setting specified by the Volatile Wiper value. See [Section 5.7](#) for additional description details.

Note: When the $\overline{\text{SHDN}}$ pin is active, the Serial Interface is not disabled, and serial interface activity is executed.



FIGURE 4-5: Hardware Shutdown Resistor Network Configuration.

4.3.1.2 Terminal Control Register

The Terminal Control (TCON) register allows the device's terminal pins to be independently removed from the application circuit. These terminal control settings do not modify the wiper setting values. Also this has no effect on the serial interface and the memory/wipers are still under full user control.

The resistor network has four TCON bits associated with it. One bit for each terminal (A, W, and B) and one to have a software configuration that matches the configuration of the $\overline{\text{SHDN}}$ pin. These bits are named R0A, R0W, R0B, and R0HW. [Register 4-1](#) describes the operation of the R0HW, R0A, R0B, and R0W bits.

Note: When the R0HW bit forces the resistor network into the hardware $\overline{\text{SHDN}}$ state, the state of the TCON register R0A, R0W, and R0B bits is overridden (ignored). When the state of the R0HW bit no longer forces the resistor network into the hardware $\overline{\text{SHDN}}$ state, the TCON register R0A, R0W, and R0B bits return to controlling the terminal connection state. That is, the R0HW bit does not corrupt the state of the R0A, R0W, and R0B bits.

[Figure 4-6](#) shows how the $\overline{\text{SHDN}}$ pin signal and the R0HW bit signal interact to control the hardware shutdown of each resistor network (independently).



FIGURE 4-6: R0HW bit and $\overline{\text{SHDN}}$ pin Interaction.

MCP41HVX1

4.3.2 WIPER LATCH

The wiper latch pin is used to control when the new wiper value in the Wiper register is transferred to the wiper. This is useful for applications that need to synchronize the wiper updates. This may be for synchronization to an external event, such as zero crossing, or to synchronize the update of multiple digital potentiometers.

When the $\overline{\text{WLAT}}$ pin is high, transfers from the Wiper register to the Wiper are inhibited. When the $\overline{\text{WLAT}}$ pin is low, transfers may occur from the Wiper register to the Wiper. Figure 4-7 shows the interaction of the $\overline{\text{WLAT}}$ pin and the loading of the Wiper.

If the external event crossing time is long, then the wiper could be updated the entire time that the $\overline{\text{WLAT}}$ signal is low. Once the $\overline{\text{WLAT}}$ signal goes high, the transfer from the Wiper register is disabled. The Wiper register can continue to be updated. Only the $\overline{\text{CS}}$ pin is used to enable/disable serial commands.

If the application does not require synchronized Wiper register updates, then the $\overline{\text{WLAT}}$ pin should be tied low.

Note 1: This feature only inhibits the data transfer from the Wiper register to the Wiper.

2: When the $\overline{\text{WLAT}}$ pin becomes active, data transferred to the Wiper will not be corrupted due to the Wiper Register Buffer getting loaded from an active SPI command.

4.3.3 DEVICE CURRENT MODES

There are two current modes for Volatile devices. These are:

- Serial Interface Inactive (Static Operation)
- Serial Interface Active

For the SPI interface, Static Operation occurs when the $\overline{\text{CS}}$ pin is at the V_{IH} voltage and the SCK pin is static (High or Low).



FIGURE 4-7: $\overline{\text{WLAT}}$ Interaction with Wiper During Serial Communication - (SPI Mode 1,1).

4.4 Memory Map

The device memory supports 16 locations that are 8-bits wide (16x8 bits). This memory space contains only volatile locations (see [Table 4-7](#)).

4.4.1 VOLATILE MEMORY (RAM)

There are two volatile memory locations. These are:

- Volatile Wiper 0
- Terminal Control (TCON0) Register 0

The volatile memory starts functioning at the RAM retention voltage (V_{RAM}). The POR/BOR Wiper code is shown in [Table 4-6](#).

[Table 4-7](#) shows this memory map and which serial commands operate (and don't) on each of these locations.

Accessing an "invalid" address (for that device) or an invalid command for that address will cause an error condition (CMDERR) on the serial interface.

TABLE 4-6: WIPER POR STANDARD SETTINGS

| Resistance Code | Typical R_{AB} Value | Default POR Wiper Setting | Wiper Code | |
|-----------------|------------------------|---------------------------|------------|-------|
| | | | 8-bit | 7-bit |
| -502 | 5.0 k Ω | Mid scale | 7Fh | 3Fh |
| -103 | 10.0 k Ω | Mid scale | 7Fh | 3Fh |
| -503 | 50.0 k Ω | Mid scale | 7Fh | 3Fh |
| -104 | 100.0 k Ω | Mid scale | 7Fh | 3Fh |

4.4.1.1 Write to Invalid (Reserved) Addresses

Any write to a reserved address will be ignored and will generate an error condition. To exit the error condition, the user must take the \overline{CS} pin to the V_{IH} level and then back to the active state (V_{IL}).

TABLE 4-7: MEMORY MAP AND THE SUPPORTED COMMANDS

| Address | Function | Allowed Commands | Disallowed Commands ⁽¹⁾ | Memory Type |
|-----------|------------------------|-----------------------------------|------------------------------------|-------------|
| 00h | Volatile Wiper 0 | Read, Write, Increment, Decrement | — | RAM |
| 01h - 03h | Reserved | none | Read, Write, Increment, Decrement | — |
| 04h | Volatile TCON Register | Read, Write | Increment, Decrement | RAM |
| 05h - 0Fh | Reserved | none | Read, Write, Increment, Decrement | — |

Note 1: This command on this address will generate an error condition. To exit the error condition, the user must take the \overline{CS} pin to the V_{IH} level and then back to the active state (V_{IL}).

MCP41HVX1

4.4.1.2 Terminal Control (TCON) Registers

The Terminal Control (TCON) Register contains 4 control bits for Wiper 0. [Register 4-1](#) describes each bit of the TCON register.

The state of each resistor network terminal connection is individually controlled. That is, each terminal connection (A, B and W) can be individually connected/disconnected from the resistor network. This allows the system to minimize the currents through the digital potentiometer.

The value that is written to this register will appear on the resistor network terminals when the serial command has completed.

On a POR/BOR, these registers are loaded with FFh, for all terminals connected. The host controller needs to detect the POR/BOR event and then update the volatile TCON register values.

REGISTER 4-1: TCON0 BITS (1) (CONTINUED)

| | | | | | | | |
|-------|-----|-----|-----|-------|-------|-------|-------|
| R-1 | R-1 | R-1 | R-1 | R/W-1 | R/W-1 | R/W-1 | R/W-1 |
| D7 | D6 | D5 | D4 | R0HW | R0A | R0W | R0B |
| bit 7 | | | | bit 0 | | | |

Legend:

| | | |
|-------------------|------------------|--|
| R = Readable bit | W = Writable bit | U = Unimplemented bit, read as '0' |
| -n = Value at POR | '1' = Bit is set | '0' = Bit is cleared x = Bit is unknown |

bit 7:4 **D7-D4:** Reserved. Forced to "1"

bit 3 **R0HW:** Resistor 0 Hardware Configuration Control bit
 This bit forces Resistor 0 into the "shutdown" configuration of the Hardware pin
 1 = Resistor 0 is NOT forced to the hardware pin "shutdown" configuration
 0 = Resistor 0 is forced to the hardware pin "shutdown" configuration

bit 2 **R0A:** Resistor 0 Terminal A (P0A pin) Connect Control bit
 This bit connects/disconnects the Resistor 0 Terminal A to the Resistor 0 Network
 1 = P0A pin is connected to the Resistor 0 Network
 0 = P0A pin is disconnected from the Resistor 0 Network

bit 1 **R0W:** Resistor 0 Wiper (P0W pin) Connect Control bit
 This bit connects/disconnects the Resistor 0 Wiper to the Resistor 0 Network
 1 = P0W pin is connected to the Resistor 0 Network
 0 = P0W pin is disconnected from the Resistor 0 Network

bit 0 **R0B:** Resistor 0 Terminal B (P0B pin) Connect Control bit
 This bit connects/disconnects the Resistor 0 Terminal B to the Resistor 0 Network
 1 = P0B pin is connected to the Resistor 0 Network
 0 = P0B pin is disconnected from the Resistor 0 Network

- Note 1:** These bits do not affect the wiper register values.
- 2:** The hardware SHDN pin (when active) overrides the state of these bits. When the SHDN pin returns to the inactive state, the TCON register will control the state of the terminals. The SHDN pin does not modify the state of the TCON bits.

5.0 RESISTOR NETWORK

The Resistor Network has either 7-bit or 8-bit resolution. Each Resistor Network allows zero scale to full-scale connections. [Figure 5-1](#) shows a block diagram for the resistive network of a device. The Resistor network has up to three external connections. These are referred to as Terminal A, Terminal B, and the Wiper (or Terminal W).

The Resistor Network is made up of several parts. These include:

- **Resistor Ladder Module**
- **Wiper**
- **Shutdown Control** (Terminal Connections)

Terminal A and B as well as the Wiper W do not have a polarity. These terminals can support both positive and negative current.

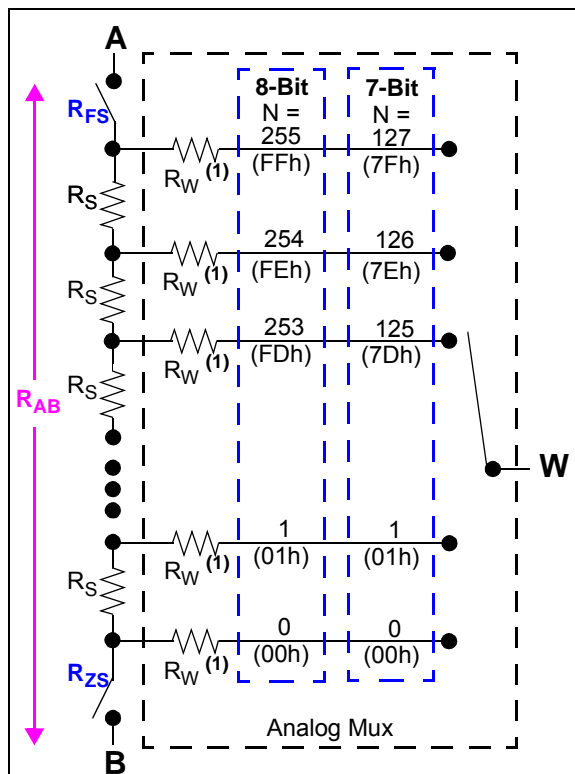

Note 1: The wiper resistance is dependent on several factors including wiper code, device V+ voltage, terminal voltages (on A, B and W), and temperature. Also for the same conditions, each tap selection resistance has a small variation. This R_W variation has greater effect on some specifications (such as INL) for the smaller resistance devices (5.0 k Ω) compared to larger resistance devices (100.0 k Ω).

FIGURE 5-1: Resistor Block Diagram.

5.1 Resistor Ladder Module

The R_{AB} resistor ladder is composed of the series of equal value Step resistors (R_S) and the Full-Scale (R_{FS}) and Zero-Scale (R_{ZS}) resistances:

$$R_{AB} = R_{ZS} + n * R_S + R_{FS}$$

Where “n” is determined by the resolution of the device. The R_{FS} and R_{ZS} resistances are discussed in [Section 5.1.3](#).

There is a connection point (tap) between each R_S resistor. Each tap point is a connection point for an analog switch. The opposite side of the analog switch is connected to a common signal which is connected to the Terminal W (Wiper) pin (see [Section 5.2](#)).

[Figure 5-1](#) shows a block diagram of the Resistor Network. The R_{AB} (and R_S) resistance has small variations over voltage and temperature.

The end points of the resistor ladder are connected to analog switches, which are connected to the device Terminal A and Terminal B pins. In the ideal case, these switches would have 0 Ω of resistance, that is $R_{FS} = R_{ZS} = 0\Omega$. This will also be referred as the Simplified model.

For an 8-bit device, there are 255 resistors in a string between Terminal A and Terminal B. The wiper can be set to tap onto any of these 255 resistors, thus providing 256 possible settings (including Terminal A and Terminal B). A wiper setting of 00h connects Terminal W (wiper) to Terminal B (Zero Scale). A wiper setting of 7Fh is the Mid-scale setting. A wiper setting of FFh connects Terminal W (wiper) to Terminal A (Full Scale). [Table 5-2](#) illustrates the full wiper setting map.

For a 7-bit device, there are 127 resistors in a string between Terminal A and Terminal B. The wiper can be set to tap onto any of these 127 resistors, thus providing 128 possible settings (including Terminal A and Terminal B). A wiper setting of 00h connects Terminal W (wiper) to Terminal B (Zero Scale). A wiper setting of 3Fh is the Mid-scale setting. A wiper setting of 7Fh connects the wiper to Terminal A (Full Scale). [Table 5-2](#) illustrates the full wiper setting map.

5.1.1 R_{AB} CURRENT (I_{RAB})

The current through the R_{AB} resistor (A pin to B pin) is dependent on the voltage on the V_A and V_B pins and the R_{AB} resistance.

EQUATION 5-1: R_{AB}

$$R_{AB} = R_{ZS} + (n * R_S) + R_{FS} = \frac{|(V_A - V_B)|}{(I_{RAB})}$$

V_A is the voltage on the V_A pin.

V_B is the voltage on the V_B pin.

I_{RAB} is the current into the V_{REF} pin.

MCP41HVX1

5.1.2 STEP RESISTANCE (R_S)

Step resistance (R_S) is the resistance from one tap setting to the next. This value will be dependent on the R_{AB} value that has been selected (and the full scale and zero scale resistances). The R_S resistors are manufactured so that they should be very consistent with each other, and track each other's values as voltage and/or temperature change.

Equation 5-2 shows the simplified and detailed equations for calculating the R_S value. The simplified equation assumes $R_{FS} = R_{ZS} = 0\Omega$. Table 5-1 shows example step resistance calculations for each device, and the variation of the detailed model ($R_{FS} \neq 0\Omega$; $R_{ZS} \neq 0\Omega$) from the simplified model ($R_{FS} = R_{ZS} = 0\Omega$). As the R_{AB} resistance option increases, the effects of the R_{ZS} and R_{FS} resistance decreases.

The total resistance of the device has minimal variation due to operating voltage (see device characterization graphs).

Equation 5-2 shows calculations for the step resistance.

EQUATION 5-2: R_S CALCULATION

Simplified Model (assumes $R_{FS} = R_{ZS} = 0\Omega$)

$$R_{AB} = (n * R_S)$$

$$R_S = \frac{R_{AB}}{n}$$

$R_S = \frac{R_{AB}}{255}$

$R_S = \frac{R_{AB}}{127}$

Detailed Model

$$R_{AB} = R_{FS} + (n * R_S) + R_{ZS}$$

$$R_S = \frac{R_{AB} - R_{FS} - R_{ZS}}{n}$$

or

$$R_S = \frac{(V_{FS} - V_{ZS})}{n I_{AB}}$$

Where:

"n" = 255 (8-bit) or 127 (7-bit)

V_{FS} is the wiper voltage at Full-Scale code

V_{ZS} is the wiper voltage at Zero-Scale code

I_{AB} is the current between Terminal A and Terminal B

TABLE 5-1: EXAMPLE STEP RESISTANCES (R_S) CALCULATIONS

| Example Resistance (Ω) | | | | | Variation % (1) | Resolution | Comment |
|---------------------------------|--------------|--------------|---------------|--------|-----------------|--------------------|----------------------|
| R_{AB} | R_{ZS} (3) | R_{FS} (3) | R_S | | | | |
| | | | Equation | Value | | | |
| 5,000 | 0 | 0 | 5,000 / 127 | 39.37 | 0 | 7-bit (127 R_S) | Simplified Model (2) |
| | 80 | 60 | 4,860 / 127 | 38.27 | -2.80 | | |
| | 0 | 0 | 5,000 / 255 | 19.61 | 0 | 8-bit (255 R_S) | Simplified Model (2) |
| | 80 | 60 | 4,860 / 255 | 19.06 | -2.80 | | |
| 10,000 | 0 | 0 | 10,000 / 127 | 78.74 | 0 | 7-bit (127 R_S) | Simplified Model (2) |
| | 80 | 60 | 9,860 / 127 | 77.64 | -1.40 | | |
| | 0 | 0 | 10,000 / 255 | 39.22 | 0 | 8-bit (255 R_S) | Simplified Model (2) |
| | 80 | 60 | 9,860 / 255 | 38.67 | -1.40 | | |
| 50,000 | 0 | 0 | 50,000 / 127 | 393.70 | 0 | 7-bit (127 R_S) | Simplified Model (2) |
| | 80 | 60 | 49,860 / 127 | 392.60 | -0.28 | | |
| | 0 | 0 | 50,000 / 255 | 196.08 | 0 | 8-bit (255 R_S) | Simplified Model (2) |
| | 80 | 60 | 49,860 / 255 | 195.53 | -0.28 | | |
| 100,000 | 0 | 0 | 100,000 / 127 | 787.40 | 0 | 7-bit (127 R_S) | Simplified Model (2) |
| | 80 | 60 | 99,860 / 127 | 786.30 | -0.14 | | |
| | 0 | 0 | 100,000 / 255 | 392.16 | 0 | 8-bit (255 R_S) | Simplified Model (2) |
| | 80 | 60 | 99,860 / 255 | 391.61 | -0.14 | | |

Note 1: Delta % from Simplified Model R_S calculation value:

2: Assumes $R_{FS} = R_{ZS} = 0\Omega$.

3: Zero-Scale (R_{ZS}) and Full-Scale (R_{FS}) resistances are dependent on many operational characteristics of the device, including the $V+$ / $V-$ voltage, the voltages on the A, B and W terminals, the wiper code selected, the R_{AB} resistance, and the temperature of the device.

5.1.3 R_{FS} AND R_{ZS} RESISTORS

The R_{FS} and R_{ZS} resistances are artifacts of the R_{AB} resistor network implementation. In the ideal model, the R_{FS} and R_{ZS} resistances would be 0Ω . These resistors are included in the block diagram to help better model the actual device operation. Equation 5-3 shows how to estimate the R_S , R_{FS} , and R_{ZS} resistances, based on the measured voltages of V_{REF} , V_{FS} , and V_{ZS} and the measured current I_{VREF} .

EQUATION 5-3: ESTIMATING R_S , R_{FS} , AND R_{ZS}

$$R_{FS} = \frac{|(V_A - V_{FS})|}{(I_{RAB})}$$

$$R_{ZS} = \frac{|(V_{ZS} - V_B)|}{(I_{RAB})}$$

$$R_S = \frac{V_S}{(I_{RAB})}$$

Where:

$$V_S = \frac{(V_{FS} - V_{ZS})}{255} \quad (8\text{-bit device})$$

$$V_S = \frac{(V_{FS} - V_{ZS})}{127} \quad (7\text{-bit device})$$

V_{FS} is the V_W voltage when the wiper code is at full-scale.

V_{ZS} is the V_W voltage when the wiper code is at zero-scale.

5.2 Wiper

The wiper terminal is connected to an analog switch mux, where one side of all the analog switches are connected together, the W terminal. The other side of each analog switch is connected to one of the taps of the R_{AB} resistor string (see Figure 5-1).

The value in the volatile wiper register selects which analog switch to close, connecting the W terminal to the selected node of the resistor ladder. The wiper register is 8-bits wide, and Table 5-2 shows the wiper value state for both 7-bit and 8-bit devices.

The wiper resistance (R_W) is the resistance of the selected analog switch in the analog mux. This resistance is dependent on many operational characteristics of the device, including the $V+$ / $V-$ voltage, the voltages on the A, B and W terminals, the wiper code selected, the R_{AB} resistance, and the temperature of the device.

When the wiper value is at zero scale (00h), the Wiper is connected closest to the B terminal. When the wiper value is at full scale (FFh for 8-bit, 7Fh for 7-bit), the Wiper is connected closest to the A terminal.

A zero-scale wiper value connects the W terminal (wiper) to the B terminal (wiper = 00h). A full-scale wiper value connects the W terminal (wiper) to the A terminal (wiper = FFh (8-bit), or wiper = 7Fh (7-bit)). In these configurations, the only resistance between the terminal W and the other terminal (A or B) is that of the analog switches.

TABLE 5-2: VOLATILE WIPER VALUE VS. WIPER POSITION

| Wiper Setting | | Properties |
|---------------|--------------|---|
| 7-bit | 8-bit | |
| 7Fh | FFh | Full Scale (W = A), Increment commands ignored |
| 7Eh - 40h | FEh - 80h | W = N |
| 3Fh | 7Fh | W = N (Mid Scale) |
| 3Eh - 01h | 7Eh - 01h | W = N |
| 00h | 00h | Zero Scale (W = B) Decrement command ignored |

MCP41HVX1

5.2.1 WIPER RESISTANCE (R_W)

Wiper resistance is significantly dependent on:

- The Resistor Network's Supply Voltage (V_{RN})
- The Resistor Network's Terminal (A, B, and W) Voltages
- Switch leakage (occurs at higher temperatures)
- I_W current

Figure 5-2 show the wiper resistance characterization data for all four R_{AB} resistances and temperatures. Each R_{AB} resistance determined the maximum wiper current based on worst case conditions $R_{AB} = R_{AB}$ maximum and at full scale code, $V_{BW} \approx V+$ (but not exceeding $V+$). The $V+$ targets were 10V, 20V, and 36V. What this graph shows is that at higher R_{AB} resistances (50 k Ω and 100 k Ω) and at the highest temperature (+125 $^{\circ}$ C), the analog switch leakage causes an increase in the measured result of R_W . Where R_W is measured in a rheostat configuration with $R_W = (V_{BW} - V_{BA}) / I_{BW}$.

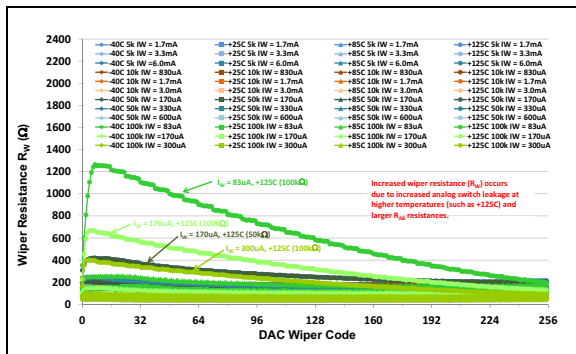

FIGURE 5-2: R_W Resistance vs R_{AB} , Wiper Current (I_W), Temperature and Wiper Code.

Since there is minimal variation of the total device resistance (R_{AB}) over voltage, at a constant temperature (see device characterization graphs), the change in wiper resistance over voltage can have a significant impact on the R_{INL} and R_{DNL} errors.

5.2.2 POTENTIOMETER CONFIGURATION

In a potentiometer configuration, the wiper resistance variation does not effect the output voltage seen on the W pin and therefore is not a significant source of error.

5.2.3 RHEOSTAT CONFIGURATION

In a rheostat configuration, the wiper resistance variation creates nonlinearity in the R_{BW} (or R_{AW}) value. The lower the nominal resistance (R_{AB}), the greater the possible relative error. Also a change in voltage needs to be taken into account. For the 5.0 k Ω device the maximum wiper resistance at 5.5V is approximately 6% of the total resistance, while at 2.7V it is approximately 6.5% of the total resistance.

5.2.4 LEVEL SHIFTERS (DIGITAL TO ANALOG)

Since the digital logic may operate anywhere within the analog power range, level shifters are present so that the digital signals control the analog circuitry. This level shifter logic is relative to the $V-$ and V_L voltages. A delta voltage of 2.7V between V_L and $V-$ is required for the serial interface to operate at the maximum specified frequency.

5.3 Terminal Currents

The terminal currents are limited by several factors, including the R_{AB} resistance (R_S resistance). The maximum current occurs when the wiper is at either the zero-scale (I_{BW}) or full-scale (I_{AW}) code. In this case, the current is only going through the analog switches (see I_T specification in [Electrical Characteristics](#)). When the current passes through at least one R_S resistive element, then the maximum terminal current (I_T) has a different limit. The current through the R_{AB} resistor is limited by the R_{AB} resistance. The worst case (max current) occurs when the resistance is at the minimum R_{AB} value.

Higher current capabilities allow a greater delta voltage between the desired terminals for a given resistance. This also allows a more usable range of wiper code val-

ues, without violating the maximum terminal current specification. [Table 5-3](#) shows resistance and current calculations based on the R_{AB} resistance (R_S resistance) for a system that supports $\pm 18V$ ($\Delta 36V$). In Rheostat configuration, the minimum wiper-code value is shown (for $V_{BW} = 36V$). As the V_{BW} voltage decreases, the minimum wiper-code value also decreases. Using a wiper code less than this value will cause the maximum terminal current (I_T) specification to be violated.

Note: For high terminal-current applications, it is recommended that proper PCB layout techniques be used to address the thermal implications of this high current. The QFN package has better thermal properties than the TSSOP package.

TABLE 5-3: TERMINAL (WIPER) CURRENT AND WIPER SETTINGS ($R_W = R_{FS} = R_{ZS} = 0\Omega$)

| R_{AB} Resistance (Ω) | | | $R_{S(MIN)}$ (Ω) | | $I_{AB(MAX)}$ (mA) (= $36V / R_{AB(MIN)}$) (1) | I_T (A, B, or W (I_W)) (mA) ($I_{BW(W=ZS)}, I_{AW(W=FS)}$) (1) | R_{BW} (Ω) (= $36V / I_T(MAX)$) (2) | Rheostat Min 'N' when $V_{BW} = 36V$ | | Rheostat $V_{BW(MAX)}$ When Wiper = 01h (V) (= $I_T(MAX) * R_{S(MIN)}$) | |
|----------------------------------|--------|---------|---------------------------|---------|--|---|--|--------------------------------------|-------|--|-------|
| | | | | | | | | 8-bit | 7-bit | 8-bit | 7-bit |
| Typical | Min | Max | 8-bit | 7-bit | | | | | | | |
| 5,000 | 4,000 | 6,000 | 15.686 | 31.496 | 9.00 | 25.0 | 1,440 | 91 | 45 | 0.392 | 0.787 |
| 10,000 | 8,000 | 12,000 | 31.373 | 62.992 | 4.50 | 12.5 | 2,880 | 91 | 45 | 0.392 | 0.787 |
| 50,000 | 40,000 | 60,000 | 156.863 | 314.961 | 0.90 | 6.5 | 5539 | 35 | 17 | 1.020 | 2.047 |
| 100,000 | 80,000 | 120,000 | 313.725 | 629.9 | 0.45 | 6.5 | 5539 | 17 | 8 | 2.039 | 4.094 |

Note 1: I_{BW} or I_{AW} currents can be much higher than this depending on voltage differential between Terminal B and Terminal W or Terminal A and Terminal W.

2: Any R_{BW} resistance greater than this limits the current.

3: If $V_{BW} = 36V$, then the wiper code value must be greater than or equal to Min 'N'. Wiper codes less than Min 'N' will cause the wiper current (I_W) to exceed the specification. Wiper codes greater than Min 'N' will cause the wiper current to be less than the maximum. The Min 'N' number has been rounded up from the calculated number to ensure that the wiper current does not exceed the maximum specification.

MCP41HVX1

Figure 5-3 through Figure 5-6 show a graph of the calculated currents (minimum, typical, and maximum) for each resistor option. These graphs are based on 25 mA (5 kΩ), 12.5 mA (10 kΩ), and 6.5 mA (50 kΩ and 100 kΩ) specifications.

To ensure no damage to the resistor network (including long-term reliability) the maximum terminal current must not be exceeded. This means that the application must assume that the R_{AB} resistance is the minimum R_{AB} value ($R_{AB(MIN)}$), see blue lines in graphs).

Looking at the 50 kΩ device, the maximum terminal current is 6.5 mA. That means that any wiper code value greater than 36 ensures that the terminal current is less than 6.5 mA. This is ~14% of the full scale value. If the application could change to the 100 kΩ device, which has the same maximum terminal current specification, any wiper-code value greater than 18 ensures that the terminal current is less than 6.5 mA. This is ~7% of the full-scale value. Supporting higher terminal current allows a greater wiper code range for a given V_{BW} voltage.



FIGURE 5-3: Maximum I_{BW} vs Wiper Code - 5 kΩ .



FIGURE 5-4: Maximum I_{BW} vs Wiper Code - 10 kΩ .



FIGURE 5-5: Maximum I_{BW} vs Wiper Code - 50 kΩ .



FIGURE 5-6: Maximum I_{BW} vs Wiper Code - 100 kΩ .

Figure 5-7 shows a graph of the maximum V_{BW} voltage vs wiper code (for 5 kΩ and 10 kΩ devices). To ensure that no damage is done to the resistor network, the $R_{AB(MIN)}$ resistance (blue line) should be used to determine V_{BW} voltages for the circuit. Devices where the R_{AB} resistance is greater than the $R_{AB(MIN)}$ resistance will naturally support a higher voltage limit.



FIGURE 5-7: Maximum V_{BW} vs Wiper Code (5 kΩ and 10 kΩ devices).

Table 5-4 shows the maximum V_{BW} voltage that can be applied across the Terminal B to Terminal W pins for a given wiper code value (for the 5 k Ω and 10 k Ω devices). These calculations assume the ideal model ($R_W = R_{FS} = R_{ZS} = 0\Omega$) and show the calculations based on $R_{S(MIN)}$ and $R_{S(MAX)}$. Table 5-5 shows the same calculations for the 50 k Ω devices, and Table 5-6 shows the calculations for the 100 k Ω devices. These tables are supplied as a quick reference.

TABLE 5-4: MAX V_{BW} AT EACH WIPER CODE ($R_W = R_{FS} = R_{ZS} = 0\Omega$) FOR $V_+ - V_- = 36V$, 5K Ω AND 10K Ω DEVICES.

| Code | | $V_{BW(MAX)}$ | | Code | | $V_{BW(MAX)}$ | | Code | | $V_{BW(MAX)}$ | |
|------|-----|---------------|--------------|------|-----|---------------|--------------|------|----------|---------------|--------------|
| Hex | Dec | $R_{S(MIN)}$ | $R_{S(MAX)}$ | Hex | Dec | $R_{S(MIN)}$ | $R_{S(MAX)}$ | Hex | Dec | $R_{S(MIN)}$ | $R_{S(MAX)}$ |
| 00h | 0 | 0.000 | 0.000 | 20h | 32 | 12.549 | 18.824 | 40h | 64 | 25.098 | |
| 01h | 1 | 0.392 | 0.588 | 21h | 33 | 12.941 | 19.412 | 41h | 65 | 25.490 | |
| 02h | 2 | 0.784 | 1.176 | 22h | 34 | 13.333 | 20.000 | 42h | 66 | 25.882 | |
| 03h | 3 | 1.176 | 1.765 | 23h | 35 | 13.725 | 20.588 | 43h | 67 | 25.275 | |
| 04h | 4 | 1.569 | 2.353 | 24h | 36 | 14.118 | 21.176 | 44h | 68 | 26.667 | |
| 05h | 5 | 1.961 | 2.941 | 25h | 37 | 14.510 | 21.765 | 45h | 69 | 27.059 | |
| 06h | 6 | 2.353 | 3.529 | 26h | 38 | 14.902 | 22.353 | 46h | 70 | 27.451 | |
| 07h | 7 | 2.745 | 4.118 | 27h | 39 | 15.294 | 22.941 | 47h | 71 | 27.843 | |
| 08h | 8 | 3.137 | 4.706 | 28h | 40 | 15.686 | 23.529 | 48h | 72 | 28.235 | |
| 09h | 9 | 3.529 | 5.294 | 29h | 41 | 16.078 | 24.118 | 49h | 73 | 28.627 | |
| 0Ah | 10 | 3.922 | 5.882 | 2Ah | 42 | 16.471 | 24.706 | 4Ah | 74 | 29.020 | |
| 0Bh | 11 | 4.314 | 6.471 | 2Bh | 43 | 16.863 | 25.294 | 4Bh | 75 | 29.412 | |
| 0Ch | 12 | 4.706 | 7.059 | 2Ch | 44 | 17.255 | 25.882 | 4Ch | 76 | 29.804 | |
| 0Dh | 13 | 5.098 | 7.647 | 2Dh | 45 | 17.647 | 26.471 | 4Dh | 77 | 30.196 | |
| 0Eh | 14 | 5.490 | 8.235 | 2Eh | 46 | 18.039 | 27.059 | 4Eh | 78 | 30.588 | |
| 0Fh | 15 | 5.882 | 8.824 | 2Fh | 47 | 18.431 | 27.647 | 4Fh | 79 | 30.980 | |
| 10h | 16 | 5.275 | 9.412 | 30h | 48 | 18.824 | 28.235 | 50h | 80 | 31.373 | |
| 11h | 17 | 6.667 | 10.000 | 31h | 49 | 19.216 | 28.824 | 51h | 81 | 31.765 | |
| 12h | 18 | 7.059 | 10.588 | 32h | 50 | 19.608 | 29.412 | 52h | 82 | 32.157 | |
| 13h | 19 | 7.451 | 11.176 | 33h | 51 | 20.000 | 30.000 | 53h | 83 | 32.549 | |
| 14h | 20 | 7.843 | 11.765 | 34h | 52 | 20.392 | 30.588 | 54h | 84 | 32.941 | |
| 15h | 21 | 8.235 | 12.353 | 35h | 53 | 20.784 | 31.176 | 55h | 85 | 33.333 | |
| 16h | 22 | 8.627 | 12.941 | 36h | 54 | 21.176 | 31.765 | 56h | 86 | 33.725 | |
| 17h | 23 | 9.020 | 13.529 | 37h | 55 | 21.569 | 32.353 | 57h | 87 | 34.118 | |
| 18h | 24 | 9.412 | 14.118 | 38h | 56 | 21.961 | 32.941 | 58h | 88 | 34.510 | |
| 19h | 25 | 9.804 | 14.706 | 39h | 57 | 22.353 | 33.529 | 59h | 89 | 34.902 | |
| 1Ah | 26 | 10.196 | 15.294 | 3Ah | 58 | 22.745 | 34.118 | 5Ah | 90 | 35.294 | |
| 1Bh | 27 | 10.588 | 15.882 | 3Bh | 59 | 23.137 | 34.706 | 5Bh | 91 | 35.686 | |
| 1Ch | 28 | 10.980 | 16.471 | 3Ch | 60 | 23.529 | 35.294 | 5Ch | 92 - 255 | 36.0 (1, 2) | |
| 1Dh | 29 | 11.373 | 17.059 | 3Dh | 61 | 23.922 | 35.882 | | | | |
| 1Eh | 30 | 11.765 | 17.647 | 3Eh | 62 | 24.314 | 36.0 (1, 2) | | | | |
| 1Fh | 31 | 12.157 | 18.235 | 3Fh | 63 | 24.706 | | | | | |

- Note 1:** Calculated R_{BW} voltage is greater than 36V (highlighted in color), must be limited to 36V ($V_+ - V_-$).
- Note 2:** This wiper code and greater will limit the I_{BW} current to less than the maximum supported terminal current (I_T).

MCP41HVX1

TABLE 5-5: MAX V_{BW} AT EACH WIPER CODE ($R_W = R_{FS} = R_{ZS} = 0\Omega$) FOR $V_+ - V_- = 36V$, $50K\Omega$ DEVICES.

| Code | | $V_{BW(MAX)}$ | | Code | | $V_{BW(MAX)}$ | | Code | | $V_{BW(MAX)}$ | |
|------|-----|---------------|--------------|------|-----|---------------|--------------|-----------|----------|---------------|--------------|
| Hex | Dec | $R_{S(MIN)}$ | $R_{S(MAX)}$ | Hex | Dec | $R_{S(MIN)}$ | $R_{S(MAX)}$ | Hex | Dec | $R_{S(MIN)}$ | $R_{S(MAX)}$ |
| 00h | 0 | 0.000 | 0.000 | 10h | 16 | 16.314 | 24.471 | 20h | 32 | 32.627 | |
| 01h | 1 | 1.020 | 1.529 | 11h | 17 | 17.333 | 26.000 | 21h | 33 | 33.647 | |
| 02h | 2 | 2.039 | 3.059 | 12h | 18 | 18.353 | 27.529 | 22h | 34 | 34.667 | |
| 03h | 3 | 3.059 | 4.588 | 13h | 19 | 19.373 | 29.059 | 23h | 35 | 35.686 | |
| 04h | 4 | 4.078 | 6.118 | 14h | 20 | 20.392 | 30.588 | 24h - FFh | 36 - 255 | 36.0 (1, 2) | |
| 05h | 5 | 5.098 | 7.647 | 15h | 21 | 21.412 | 32.118 | | | | |
| 06h | 6 | 6.118 | 9.176 | 16h | 22 | 22.431 | 33.647 | | | | |
| 07h | 7 | 7.137 | 10.706 | 17h | 23 | 23.451 | 35.176 | | | | |
| 08h | 8 | 8.157 | 12.235 | 18h | 24 | 24.471 | 36.0 (1, 2) | | | | |
| 09h | 9 | 9.176 | 13.765 | 19h | 25 | 25.490 | | | | | |
| 0Ah | 10 | 10.196 | 15.294 | 1Ah | 26 | 26.510 | | | | | |
| 0Bh | 11 | 11.216 | 16.824 | 1Bh | 27 | 27.529 | | | | | |
| 0Ch | 12 | 12.235 | 18.353 | 1Ch | 28 | 28.549 | | | | | |
| 0Dh | 13 | 13.255 | 19.882 | 1Dh | 29 | 29.569 | | | | | |
| 0Eh | 14 | 14.275 | 21.412 | 1Eh | 30 | 30.588 | | | | | |
| 0Fh | 15 | 15.294 | 22.941 | 1Fh | 31 | 31.608 | | | | | |

- Note** 1: Calculated R_{BW} voltage is greater than 36V (highlighted in color), must be limited to 36V ($V_+ - V_-$).
 2: This wiper code and greater will limit the I_{BW} current to less than the maximum supported terminal current (I_T).

TABLE 5-6: MAX V_{BW} AT EACH WIPER CODE ($R_W = R_{FS} = R_{ZS} = 0\Omega$) FOR $V_+ - V_- = 36V$, $100K\Omega$ DEVICES.

| Code | | $V_{BW(MAX)}$ | | Code | | $V_{BW(MAX)}$ | |
|------|-----|---------------|--------------|-----------|----------|---------------|--------------|
| Hex | Dec | $R_{S(MIN)}$ | $R_{S(MAX)}$ | Hex | Dec | $R_{S(MIN)}$ | $R_{S(MAX)}$ |
| 00h | 0 | 0.000 | 0.000 | 10h | 16 | 32.627 | |
| 01h | 1 | 2.039 | 3.059 | 11h | 17 | 34.667 | |
| 02h | 2 | 4.078 | 6.118 | 12h - FFh | 18 - 255 | 36.0 (1, 2) | |
| 03h | 3 | 6.118 | 9.176 | | | | |
| 04h | 4 | 8.157 | 12.235 | | | | |
| 05h | 5 | 10.196 | 15.294 | | | | |
| 06h | 6 | 12.235 | 18.353 | | | | |
| 07h | 7 | 14.275 | 21.412 | | | | |
| 08h | 8 | 16.314 | 24.471 | | | | |
| 09h | 9 | 18.353 | 27.529 | | | | |
| 0Ah | 10 | 20.392 | 30.588 | | | | |
| 0Bh | 11 | 22.431 | 33.647 | | | | |
| 0Ch | 12 | 24.471 | 36.0 (1, 2) | | | | |
| 0Dh | 13 | 26.510 | | | | | |
| 0Eh | 14 | 28.549 | | | | | |
| 0Fh | 15 | 30.588 | | | | | |

- Note** 1: Calculated R_{BW} voltage is greater than 36V (highlighted in color), must be limited to 36V ($V_+ - V_-$).
 2: This wiper code and greater will limit the I_{BW} current to less than the maximum supported terminal current (I_T).

5.4 Variable Resistor (Rheostat)

A variable resistor is created using terminal W and either terminal A or Terminal B. Since the wiper-code value of 0 connects the wiper to the terminal B, the R_{BW} resistance increases with increasing wiper code value. Conversely, the R_{AW} resistance will decrease with increasing wiper code value. Figure 5-8 shows the connections from a potentiometer to create a rheostat configuration.

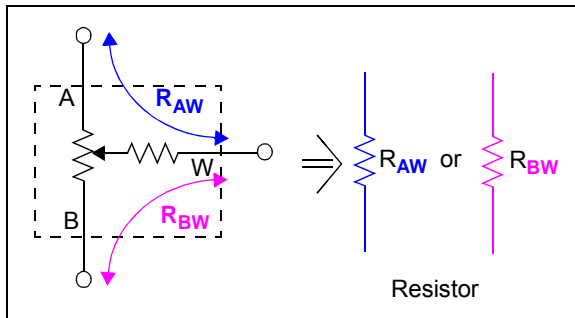

FIGURE 5-8: Rheostat Configuration.

Equation 5-4 shows the R_{BW} and R_{AW} calculations. The R_{BW} calculation is for the resistance between the wiper and terminal B. The R_{AW} calculation is for the resistance between the wiper and terminal A.

EQUATION 5-4: R_{BW} AND R_{AW} CALCULATION

Simplified Model (assumes $R_{FS} = R_{ZS} = 0\Omega$)

$$R_{BW} = (n * R_S)$$

$$R_{AW} = ((FSV - n) * R_S)$$

Where:

$$R_S = \frac{R_{AB}}{\text{Resolution}}$$

n = wiper code

FSV = The full scale vale
(255 for 8-bit or 127 for 7-bit)

| | | |
|----------------------------|----------------------------|--------------|
| | 8-bit | 7-bit |
| $R_S = \frac{R_{AB}}{255}$ | $R_S = \frac{R_{AB}}{127}$ | |

Detailed Model

$$R_{BW} = R_{ZS} + (n * R_S)$$

$$R_{AW} = R_{FS} + ((FSV - n) * R_S)$$

Where:

n = wiper code

FSV = The full scale vale
(255 for 8-bit or 127 for 7-bit)

5.5 Analog Circuitry Power Requirements

This device has two power supplies. One is for the digital interface (V_L and DGND) and the other is for the high voltage analog circuitry ($V+$ and $V-$). The maximum delta voltage between $V+$ and $V-$ is 36V. The digital power signals must be between $V+$ and $V-$.

If the digital ground (DGND) pin is at half the potential of $V+$ (relative to $V-$), then the terminal pins potentials can be $\pm(V+/2)$ relative to DGND.

Figure 5-9 shows the relationship of the four power signals. This shows that the $V+$ / $V-$ signals do not need to be symmetric around the DGND signal.

To ensure that the wiper register has been properly loaded with the POR/BOR value, the V_L voltage must be at the minimum specified operating voltage (referenced to DGND).

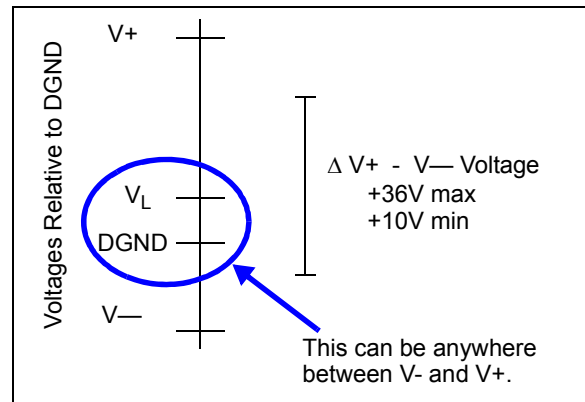

FIGURE 5-9: Analog Circuitry Voltage Ranges.

5.6 Resistor Characteristics

5.6.1 $V+$ / $V-$ LOW VOLTAGE OPERATION

The resistor network is specified from 20V to 36V. At voltages below 20V, the resistor network will function, but the operational characteristics may be outside the specified limits. Please refer to Section 2.0 "Typical Performance Curves" for additional information.

5.6.2 RESISTOR TEMPCO

Biasing the ends (Terminal A and Terminal B) near mid-supply ($(V+ - |V-|) / 2$) will give the worst switch resistance tempco.

MCP41HVX1

5.7 Shutdown Control

Shutdown is used to minimize the device's current consumption. The MCP41HVX1 has two methods to achieve this:

- **Hardware Shutdown Pin (SHDN)**
- **Terminal Control Register (TCON)**

The Hardware Shutdown pin is backwards compatible with the MCP42X1 devices.

5.7.1 HARDWARE SHUTDOWN PIN (SHDN)

The $\overline{\text{SHDN}}$ pin is available on the potentiometer devices. When the $\overline{\text{SHDN}}$ pin is forced active (V_{IL}):

- The P0A terminal is disconnected
- The P0W terminal is connected to the P0B terminal (see [Figure 4-5](#))
- The Serial Interface is NOT disabled, and all Serial Interface activity is executed

The Hardware Shutdown pin mode does NOT corrupt the values in the Volatile Wiper Registers nor the TCON register. When the Shutdown mode is exited ($\overline{\text{SHDN}}$ pin is inactive (V_{IH})):

- The device returns to the Wiper setting specified by the Volatile Wiper value
- The TCON register bits return to controlling the terminal connection state



FIGURE 5-10: Hardware Shutdown Resistor Network Configuration.

5.7.2 TERMINAL CONTROL REGISTER (TCON)

The Terminal Control (TCON) register is a volatile register used to configure the connection of each resistor network terminal pin (A, B and W) to the Resistor Network. This register is shown in [Register 4-1](#).

The R0HW bit forces the selected resistor network into the same state as the $\overline{\text{SHDN}}$ pin. Alternate low-power configurations may be achieved with the R0A, R0W and R0B bits.

When the R0HW bit is "0":

- The P0A terminal is disconnected
- The P0W terminal is simultaneously connect to the P0B terminal (see [Figure 5-11](#))

Note: When the R0HW bit forces the resistor network into the hardware $\overline{\text{SHDN}}$ state, the state of the TCON0 register's R0A, R0W and R0B bits is overridden (ignored). When the state of the R0HW bit no longer forces the resistor network into the hardware $\overline{\text{SHDN}}$ state, the TCON0 register's R0A, R0W and R0B bits return to controlling the terminal connection state. In other words, the R0HW bit does not corrupt the state of the R0A, R0W and R0B bits.

The R0HW bit does NOT corrupt the values in the Volatile Wiper registers nor the TCON register. When the Shutdown mode is exited (R0HW bit = 1):

- The device returns to the Wiper setting specified by the Volatile Wiper value
- The TCON register bits return to controlling the terminal connection state

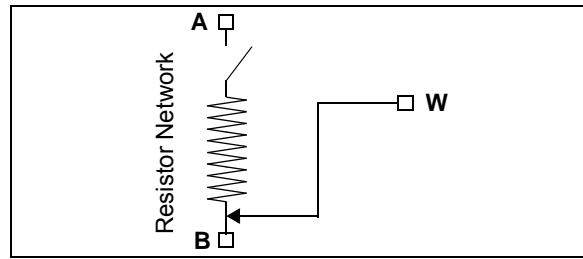

FIGURE 5-11: Resistor Network Shutdown State ($R0HW = 0$).

5.7.3 INTERACTION OF $\overline{\text{SHDN}}$ PIN AND TCON REGISTER

[Figure 4-6](#) shows how the $\overline{\text{SHDN}}$ pin signal and the R0HW bit signal interact to control the hardware shutdown of the resistor network.

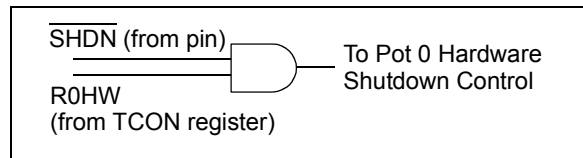

FIGURE 5-12: R0HW bit and $\overline{\text{SHDN}}$ pin Interaction.

6.0 SERIAL INTERFACE (SPI)

The MCP41HVX1 devices support the SPI serial protocol. This SPI operates in the Slave mode (does not generate the serial clock). The device's SPI command format operates on multiples of 8-bits.

The SPI interface uses up to four pins. These are:

- $\overline{\text{CS}}$ – Chip Select
- SCK – Serial Clock
- SDI – Serial Data In
- SDO – Serial Data Out

A typical SPI interface is shown in [Figure 6-1](#). In the SPI interface, the Master's Output pin is connected to the Slave's Input pin and the Master's Input pin is connected to the Slave's Output pin.

The MCP41HVX1 SPI's module supports two (of the four) standard SPI modes. These are Mode 0,0 and 1,1. The SPI mode is determined by the state of the SCK pin (V_{IH} or V_{IL}) on the when the $\overline{\text{CS}}$ pin transitions from inactive (V_{IH}) to active (V_{IL}).

Note: Some Host Controller SPI modules only operate with 16-bit transfers. For these Host Controllers, only the Read and Write Commands may be used, or the Continuous Increment or Decrement Commands that are an even multiple of Increment or Decrement commands.



FIGURE 6-1: Typical SPI Interface Block Diagram.

MCP41HVX1

6.1 SDI, SDO, SCK, and $\overline{\text{CS}}$ Operation

The operation of the four SPI interface pins are discussed in this section. These pins are:

- [Serial Data In \(SDI\)](#)
- [Serial Data Out \(SDO\)](#)
- [Serial Clock \(SCK\)](#)
- [The Chip Select Signal \(CS\)](#)

The serial interface works on either 8-bit or 16-bit boundaries depending on the selected command. The Chip Select ($\overline{\text{CS}}$) pin frames the SPI commands.

6.1.1 SERIAL DATA IN (SDI)

The Serial Data In (SDI) signal is the data signal into the device. The value on this pin is latched on the rising edge of the SCK signal.

6.1.2 SERIAL DATA OUT (SDO)

The Serial Data Out (SDO) signal is the data signal out of the device. The value on this pin is driven on the falling edge of the SCK signal.

Once the $\overline{\text{CS}}$ pin is forced to the active level (V_{IL}), the SDO pin will be driven. The state of the SDO pin is determined by the serial bit's position in the command, the command selected, and if there is a command error state (CMDERR).

6.1.3 SERIAL CLOCK (SCK)

The Serial Clock (SCK) signal is the clock signal of the SPI module. The frequency of the SCK pin determines the SPI frequency of operation.

The SPI interface is specified to operate up to 10 MHz. The actual clock rate depends on the configuration of the system and the serial command used. [Table 6-1](#) shows the SCK frequency.

TABLE 6-1: SCK FREQUENCY

| V_{L} Voltage | Command | | Comment |
|---------------------------|---------|-----------------------------------|------------------|
| | Read | Write, Increment, Decrement | |
| 2.7V | 10 MHz | 10 MHz | |
| 1.8V | 1 MHz | 1 MHz | DGND = V- + 0.9V |
| 2.0V | 1 MHz | 1 MHz | DGND = V- |

6.1.4 THE CHIP SELECT SIGNAL ($\overline{\text{CS}}$)

The Chip Select ($\overline{\text{CS}}$) signal is used to select the device and frame a command sequence. To start a command, or sequence of commands, the $\overline{\text{CS}}$ signal must transition from the inactive state (V_{IH}) to an active state (V_{IL}).

After the $\overline{\text{CS}}$ signal has gone active, the SDO pin is driven and the clock bit counter is reset.

Note: There is a required delay after the $\overline{\text{CS}}$ pin goes active to the 1st edge of the SCK pin.

If an error condition occurs for an SPI command, then the command byte's Command Error (CMDERR) bit (on the SDO pin) will be driven low (V_{IL}). To exit the error condition, the user must take the $\overline{\text{CS}}$ pin to the V_{IH} level.

When the $\overline{\text{CS}}$ pin returns to the inactive state (V_{IH}), the SPI module resets (including the Address Pointer). While the $\overline{\text{CS}}$ pin is in the inactive state (V_{IH}), the serial interface is ignored. This allows the host controller to interface to other SPI devices using the same SDI, SDO and SCK signals.

6.1.5 LOW VOLTAGE SUPPORT

The Serial Interface is designed to also support 1.8V operation (at reduced specifications - frequency, thresholds, etc.). This allows the MCP41HVX1 device to interface to low-voltage host controllers.

At 1.8V V_{L} operation, the DGND signal must be 0.9V or greater above the V- signal. If V_{L} is 2.0V or greater, than the DGND signal can be tied to the V- signal (see [Table 6-1](#)).

6.1.6 SPLIT RAIL SUPPORT

The Serial Interface is designed to support split rail systems. In a split rail system, the microcontroller can operate at a lower voltage than the MCP41HVX1 device. This is achieved with the V_{IH} specification.

For $V_{\text{L}} \geq 2.7\text{V}$, the minimum $V_{\text{IH}} = 0.45 * V_{\text{L}}$. So if the microcontroller V_{OH} at 1.8V is $0.8 * V_{\text{DD}}$, then V_{L} can be a maximum of 3.2V (see [Equation 6-1](#)).

See [Section 8.1](#) for additional discussion on split rail support.

EQUATION 6-1: CALCULATING MAX V_{L} FOR MICROCONTROLLER AT 1.8V

If $V_{\text{OH}} = 0.8 * V_{\text{DD}} = 0.8 * 1.8\text{V} = 1.44\text{V}$
 Then: $V_{\text{IH(MIN)}} = 1.44\text{V}$
 With $V_{\text{IH}} = 0.45 * V_{\text{L}}$
 Then: $V_{\text{L}} = 1.44\text{V} / 0.45 = \mathbf{3.2V}$

6.2 The SPI Modes

The SPI module supports two (of the four) standard SPI modes. These are Mode 0,0 and 1,1. The mode is determined by the state of the SDI pin on the rising edge of the first clock bit (of the 8-bit byte).

6.2.1 MODE 0,0

In **Mode 0,0**: SCK Idle state = low (V_{IL}), data is clocked in on the SDI pin on the rising edge of SCK and clocked out on the SDO pin on the falling edge of SCK.

6.2.2 MODE 1,1

In **Mode 1,1**: SCK Idle state = high (V_{IH}), data is clocked in on the SDI pin on the rising edge of SCK and clocked out on the SDO pin on the falling edge of SCK.

6.3 SPI Waveforms

Figure 6-2 through Figure 6-5 show the different SPI command waveforms. Figure 6-2 and Figure 6-3 are read and write commands. Figure 6-4 and Figure 6-5 are Increment and Decrement commands.

6.4 Daisy Chaining

This SPI Interface does **NOT** support daisy chaining.



FIGURE 6-2: 16-Bit Commands (Write, Read) – SPI Waveform (Mode 1,1).



FIGURE 6-3: 16-Bit Commands (Write, Read) – SPI Waveform (Mode 0,0).

MCP41HVX1



FIGURE 6-4: 8-Bit Commands (Increment, Decrement) – SPI Waveform with PIC MCU (Mode 1,1).



FIGURE 6-5: 8-Bit Commands (Increment, Decrement) – SPI Waveform with PIC MCU (Mode 0,0).

7.0 DEVICE COMMANDS

The MCP41HVX1's SPI command format supports 16 memory address locations and four commands. These commands are shown in Table 7-1.

Commands may be sent when the \overline{CS} pin is driven to V_{IL} . The 8-bit commands (Increment Wiper and Decrement Wiper commands) contain a command byte, see Figure 7-1, while 16-bit commands (Read Data and Write Data commands) contain a command byte and a data byte. The command byte contains two data bits, see Figure 7-1.

Table 7-2 shows the supported commands for each memory location and the corresponding values on the SDI and SDO pins.

TABLE 7-1: COMMANDS

| C1:C0 Bit States | Command Name | # of Bits |
|------------------|-----------------|-----------|
| 11 | Read Data | 16-Bits |
| 00 | Write Data | 16-Bits |
| 01 | Increment Wiper | 8-Bits |
| 10 | Decrement Wiper | 8-Bits |

7.1 Command Format

All commands have a **Command Byte**, which specifies the register address and the command. Commands which require data (write and read commands), also have the **Data Byte**.

7.1.1 COMMAND BYTE

The command byte has three fields, the address, the command, and two data bits, see Figure 7-1. Currently only one of the data bits is defined (D8). This is for the Write command.

The device memory is accessed when the master sends a proper command byte to select the desired operation. The memory location to be accessed is contained in the command byte's AD3:AD0 bits. The action desired is contained in the command byte's C1:C0 bits, see Table 7-1. C1:C0 determines if the desired memory location will be read, written, incremented (wiper setting +1) or decremented (wiper setting -1). The Increment and Decrement commands are only valid on the volatile wiper registers.

As the command byte is being loaded into the device (on the SDI pin), the device's SDO pin is driving. The SDO pin will output high bits for the first six bits of that command. On the 7th bit, the SDO pin will output the CMDERR bit state (see Section 7.1.1.1 "Error Condition"). The 8th bit state depends on the command selected.

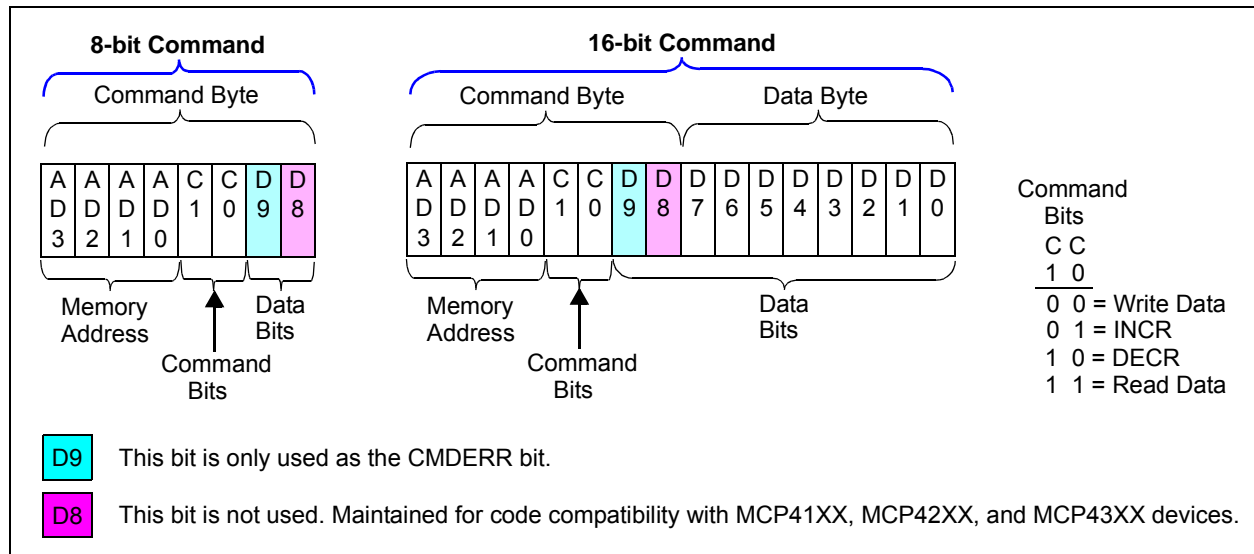

FIGURE 7-1: General SPI Command Formats.

MCP41HVX1

TABLE 7-2: MEMORY MAP AND THE SUPPORTED COMMANDS

| Address | | Command | Data (10-bits) ⁽¹⁾ | SPI String (Binary) | |
|-----------------------------|---------------------------|-----------------|----------------------------------|---------------------|-------------------------------|
| Value | Function | | | MOSI (SDI pin) | MISO (SDO pin) ⁽²⁾ |
| 00h | Volatile Wiper 0 | Write Data | nn nnnn nnnn | 0000 00nn nnnn nnnn | 1111 1111 1111 1111 |
| | | Read Data | nn nnnn nnnn | 0000 11nn nnnn nnnn | 1111 111n nnnn nnnn |
| | | Increment Wiper | — | 0000 0100 | 1111 1111 |
| | | Decrement Wiper | — | 0000 1000 | 1111 1111 |
| 01h - 03h ⁽⁴⁾ | Reserved | — | — | — | — |
| 04h ⁽³⁾ | Volatile TCON Register | Write Data | nn nnnn nnnn | 0100 00nn nnnn nnnn | 1111 1111 1111 1111 |
| | | Read Data | nn nnnn nnnn | 0100 11nn nnnn nnnn | 1111 111n nnnn nnnn |
| 05h - 0Fh ⁽⁴⁾ | Reserved | — | — | — | — |

- Note 1:** The data memory is 8-bits wide, so the two MSBs (D9:D8) are ignored by the device.
- Note 2:** All these address/command combinations are valid, so the CMDERR bit is set. Any other address/command combination is a command error state and the CMDERR bit will be clear.
- Note 3:** Increment or Decrement commands are invalid for these addresses.
- Note 4: Reserved addresses:** Any command is invalid for these addresses.

7.1.1.1 Error Condition

The CMDERR bit indicates if the four address bits received (AD3:AD0) and the two command bits received (C1:C0) are a valid combination. The CMDERR bit is high if the combination is valid and low if the combination is invalid (see [Table 7-3](#)).

The command error bit will also be low if a write to a Reserved Address has been specified. SPI commands that do not have a multiple of eight clocks are ignored.

Once an error condition has occurred, any following commands are ignored. All following SDO bits will be low until the CMDERR condition is cleared by forcing the CS pin to the inactive state (V_{IH}).

TABLE 7-3: COMMAND ERROR BIT

| CMDERR Bit States | Description |
|-------------------|---------------------------------------|
| 1 | "Valid" Command/Address combination |
| 0 | "Invalid" Command/Address combination |

Aborting a Transmission

All SPI transmissions must have the correct number of SCK pulses to be executed. The command is not executed until the complete number of clocks have been received. Some commands also require the CS pin to be forced inactive (V_{IH}). If the CS pin is forced to the inactive state (V_{IH}), the serial interface is reset. Partial commands are not executed.

SPI is more susceptible to noise than other bus protocols. The most likely case is that this noise corrupts the value of the data being clocked into the MCP41HVX1 or the SCK pin is injected with extra clock pulses. This may cause data to be corrupted in the device, or a command error to occur, since the address and command bits were not a valid combination. The extra SCK pulse will also cause the SPI data (SDI) and clock (SCK) to be out of sync. Forcing the CS pin to the inactive state (V_{IH}) resets the serial interface. The SPI interface will ignore activity on the SDI and SCK pins until the CS pin transition to the active state is detected (V_{IH} to V_{IL}).

Note 1: When data is not being received by the MCP41HVX1, it is recommended that the CS pin be forced to the inactive level (V_{IL})

2: It is also recommended that long continuous command strings should be broken down into single commands or shorter continuous command strings. This reduces the probability of noise on the SCK pin corrupting the desired SPI commands.

7.1.2 DATA BYTE

Only the Read command and the Write command use the data byte, see [Figure 7-1](#). These commands concatenate the 8 bits of the data byte with the one data bit (D8) contained in the command byte to form 9-bits of data (D8:D0). The command byte format supports up to 9-bits of data, but the MCP41HVX1 only uses the lower 8-bits. That means that the Full Scale code of the 8-bit resistor network is FFh. When at Full Scale, the wiper connects to Terminal A. The D8 bit is maintained for code compatibility with the MCP41XX, MCP42XX, and MCP43XX devices.

The D9 bit is currently unused, and corresponds to the position on the SDO data of the CMDERR bit.

7.1.3 CONTINUOUS COMMANDS

The device supports the ability to execute commands continuously while the CS pin is in the active state (V_{IL}). Any sequence of valid commands may be received.

The following example is a valid sequence of events:

1. CS pin driven active (V_{IL}).
2. Read Command.
3. Increment Command (Wiper 0).
4. Increment Command (Wiper 0).
5. Decrement Command (Wiper 0).
6. Write Command.
7. Read Command.
8. CS pin driven inactive (V_{IH}).

Note 1: It is recommended that while the CS pin is active, only one type of command should be issued. When changing commands, it is recommended to take the CS pin inactive, then force it back to the active state.

2: It is also recommended that long command strings should be broken down into shorter command strings. This reduces the probability of noise on the SCK pin corrupting the desired SPI command string.

MCP41HVX1

7.2 Write Data

The Write command is a 16-bit command. The format of the command is shown in Figure 7-2.

A Write command to a volatile memory location changes that location after a properly formatted Write command (16-clock) has been received.

7.2.1 SINGLE WRITE TO VOLATILE MEMORY

The write operation requires that the \overline{CS} pin be in the active state (V_{IL}). Typically, the \overline{CS} pin will be in the inactive state (V_{IH}) and is driven to the active state (V_{IL}). The 16-bit Write command (command byte and data byte) is then clocked (SCK pin) in on the SDI pin. Once all 16 bits have been received, the specified volatile address is updated. A write will not occur if the write command isn't exactly 16 clocks pulses.

Figure 6-2 and Figure 6-3 show possible waveforms for a single write.



FIGURE 7-2: Write Command – SDI and SDO States.

7.2.2 CONTINUOUS WRITES TO VOLATILE MEMORY

Continuous writes are possible only when writing to the volatile memory registers (address 00h and 04h).

Figure 7-3 shows the sequence for three continuous writes. The writes do not need to be to the same volatile memory address.



FIGURE 7-3: Continuous Write Sequence.

MCP41HVX1

7.3 Read Data

The Read command is a 16-bit command. The format of the command is shown in Figure 7-4.

The first six bits of the Read command determine the address and the command. The 7th clock will output the CMDERR bit on the SDO pin. The 8th clock will be fixed at 1, and the remaining 8-clocks the device will transmit the eight data bits (D7:D0) of the specified address (AD3:AD0).

Figure 7-4 shows the SDI and SDO information for a Read command.

7.3.1 SINGLE READ

The read operation requires that the \overline{CS} pin be in the active state (V_{IL}). Typically, the \overline{CS} pin will be in the inactive state (V_{IH}) and is driven to the active state (V_{IL}). The 16-bit Read command (command byte and data byte) is then clocked (SCK pin) in on the SDI pin. The SDO pin starts driving data on the 7th bit (CMDERR bit) and the addressed data comes out on the 8th through 16th clocks. Figure 6-2 through Figure 6-3 show possible waveforms for a single read.



FIGURE 7-4: Read Command – SDI and SDO States.

7.3.2 CONTINUOUS READS

Continuous reads allow the device's memory to be read quickly. Continuous reads are possible to all memory locations.

Figure 7-5 shows the sequence for three continuous reads. The reads do not need to be to the same memory address.



FIGURE 7-5: Continuous Read Sequence.

MCP41HVX1

7.4 Increment Wiper

The Increment command is an 8-bit command. The Increment command can only be issued to specific volatile memory locations (the Wiper register). The format of the command is shown in Figure 7-6.

An Increment command to the volatile memory location changes that location after a properly formatted command (8-clocks) have been received.

Increment commands provide a quick and easy method to modify the value of the volatile wiper location by +1 with minimal overhead.



FIGURE 7-6: Increment Command – SDI and SDO States.

Note: Table 7-2 shows the valid addresses for the Increment Wiper command. Other addresses are invalid.

7.4.1 SINGLE INCREMENT

Typically, the CS pin starts at the inactive state (V_{IH}), but may already be in the active state due to the completion of another command.

Figure 6-4 through Figure 6-5 show possible waveforms for a single increment. The increment operation requires that the CS pin be in the active state (V_{IL}). Typically, the CS pin will be in the inactive state (V_{IH}) and is driven to the active state (V_{IL}). The 8-bit Increment command (command byte) is then clocked in on the SDI pin by the SCK pins. The SDO pin drives the CMDERR bit on the 7th clock.

The wiper value will increment up to FFh on 8-bit devices and 7Fh on 7-bit devices. After the wiper value has reached full scale (8-bit = FFh, 7-bit = 7Fh), the wiper value will not be incremented further. See Table 7-4 for additional information on the Increment command versus the current volatile wiper value.

The increment operations only require the Increment command byte while the CS pin is active (V_{IL}) for a single increment.

After the wiper is incremented to the desired position, the CS pin should be forced to V_{IH} to ensure that unexpected transitions on the SCK pin do not cause the wiper setting to change. Driving the CS pin to V_{IH} should occur as soon as possible (within device specifications) after the last desired increment occurs.

TABLE 7-4: INCREMENT OPERATION VS. VOLATILE WIPER VALUE

| Current Wiper Setting | | Wiper (W) Properties | Increment Command Operates? |
|-----------------------|------------|----------------------|-----------------------------|
| 7-bit Pot | 8-bit Pot | | |
| 7Fh | FFh | Full Scale (W = A) | No |
| 7Eh 40h | FEh 80h | W = N | Yes |
| 3Fh | 7Fh | W = N (Mid-scale) | |
| 3Eh 01h | 7Eh 01h | W = N | |
| 00h | 00h | Zero Scale (W = B) | Yes |

7.4.2 CONTINUOUS INCREMENTS

Continuous increments are possible only when writing to the volatile Wiper registers (address 00h).

Figure 7-7 shows a continuous increment sequence.

When executing a continuous Increment command, the selected wiper will be altered from n to n+1 for each Increment command received. The wiper value will increment up to FFh on 8-bit devices and 7Fh on 7-bit devices. After the wiper value has reached full scale (8-bit = FFh, 7-bit = 7Fh), the wiper value will not be incremented further.

Increment commands can be sent repeatedly without raising \overline{CS} until a desired condition is met.

When executing a continuous command string, the Increment command can be followed by any other valid command.

The wiper terminal will move after the command has been received (8th clock).

After the wiper is incremented to the desired position, the \overline{CS} pin should be forced to V_{IH} to ensure that unexpected transitions (on the SCK pin do not cause the wiper setting to change). Driving the \overline{CS} pin to V_{IH} should occur as soon as possible (within device specifications) after the last desired increment occurs.

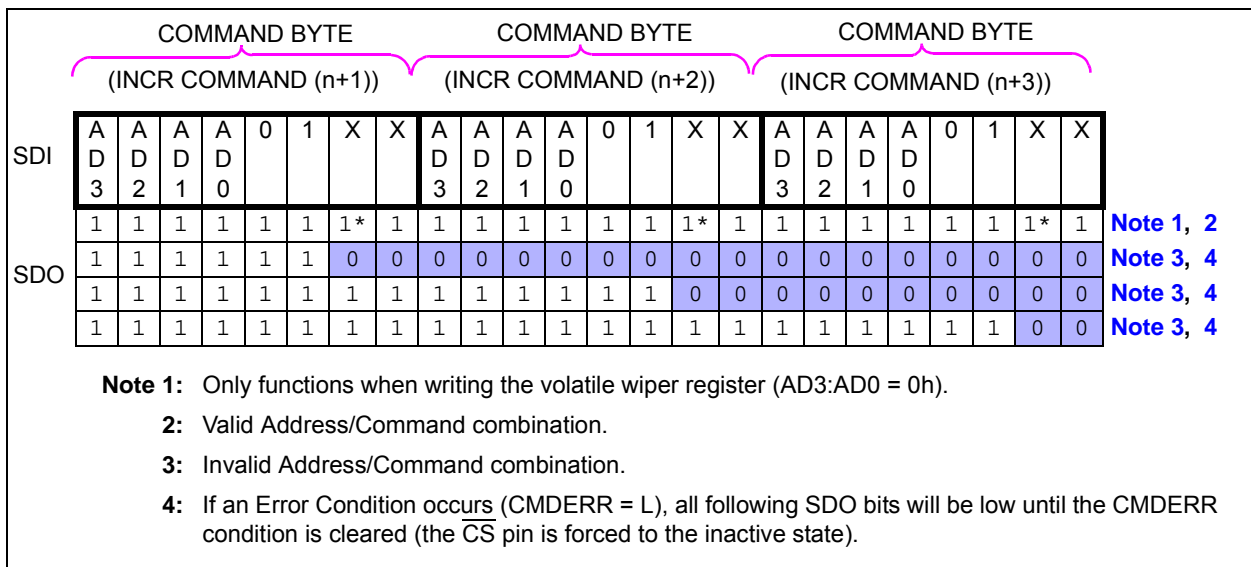

FIGURE 7-7: Continuous Increment Command – SDI and SDO States.

MCP41HVX1

7.5 Decrement Wiper

The Decrement command is an 8-bit command. The Decrement command can only be issued to volatile Wiper locations. The format of the command is shown in Figure 7-8.

A Decrement command to the volatile Wiper location changes that location after a properly formatted command (8 clocks) have been received.

Decrement commands provide a quick and easy method to modify the value of the volatile wiper location by -1 with minimal overhead.

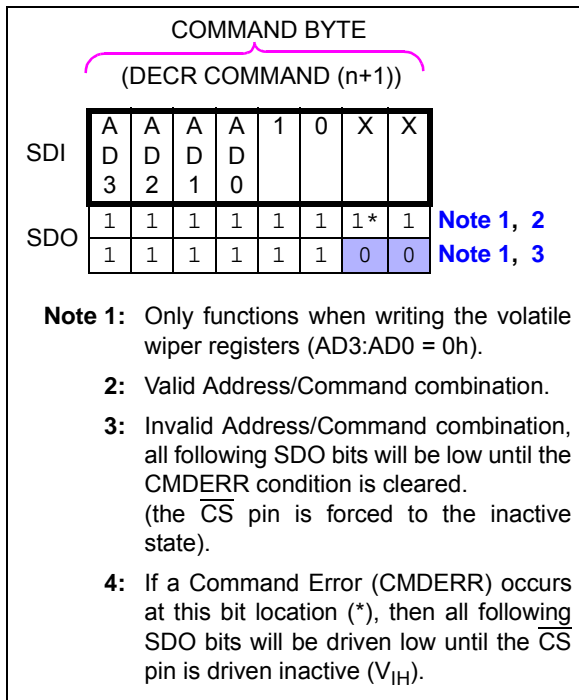

FIGURE 7-8: Decrement Command – SDI and SDO States.

Note: Table 7-2 shows the valid addresses for the Decrement Wiper command. Other addresses are invalid.

7.5.1 SINGLE DECREMENT

Typically, the \overline{CS} pin starts at the inactive state (V_{IH}), but may already be in the active state due to the completion of another command.

Figure 6-4 through Figure 6-5 show possible waveforms for a single decrement. The decrement operation requires that the \overline{CS} pin be in the active state (V_{IL}). Typically, the \overline{CS} pin will be in the inactive state (V_{IH}) and is driven to the active state (V_{IL}). Then the 8-bit Decrement command (command byte) is clocked in on the SDI pin by the SCK pin. The SDO pin drives the CMDERR bit on the 7th clock.

The wiper value will decrement from the wiper's full scale value (FFh on 8-bit devices and 7Fh on 7-bit devices). If the wiper register has a zero scale value (00h), then the wiper value will not decrement. See Table 7-5 for additional information on the Decrement command vs. the current volatile wiper value.

The Decrement commands only require the Decrement command byte, while the \overline{CS} pin is active (V_{IL} or V_{IH}) for a single decrement.

After the wiper is decremented to the desired position, the \overline{CS} pin should be forced to V_{IH} to ensure that unexpected transitions on the SCK pin do not cause the wiper setting to change. Driving the \overline{CS} pin to V_{IH} should occur as soon as possible (within device specifications) after the last desired decrement occurs.

TABLE 7-5: DECREMENT OPERATION VS. VOLATILE WIPER VALUE

| Current Wiper Setting | | Wiper (W) Properties | Decrement Command Operates? |
|-----------------------|------------|----------------------|-----------------------------|
| 7-bit Pot | 8-bit Pot | | |
| 7Fh | FFh | Full Scale (W = A) | Yes |
| 7Eh 40h | FEh 80h | W = N | Yes |
| 3Fh | 7Fh | W = N (Mid-scale) | |
| 3Eh 01h | 7Eh 01h | W = N | |
| 00h | 00h | Zero Scale (W = B) | No |

7.5.2 CONTINUOUS DECREMENTS

Continuous decrements are possible only when writing to the volatile Wiper register (address 00h).

Figure 7-9 shows a continuous decrement sequence.

When executing continuous Decrement commands, the selected wiper will be altered from n to n-1 for each Decrement command received. The wiper value will decrement from the wiper's full scale value (FFh on 8-bit devices and 7Fh on 7-bit devices). If the Wiper register has a zero scale value (00h), then the wiper value will not decrement. See Table 7-5 for additional information on the Decrement command vs. the current volatile wiper value.

Decrement commands can be sent repeatedly without raising \overline{CS} until a desired condition is met.

When executing a continuous command string, the Decrement command can be followed by any other valid command.

The wiper terminal will move after the command has been received (8th clock).

After the wiper is decremented to the desired position, the \overline{CS} pin should be forced to V_{IH} to ensure that "unexpected" transitions (on the SCK pin do not cause the wiper setting to change). Driving the \overline{CS} pin to V_{IH} should occur as soon as possible (within device specifications) after the last desired decrement occurs.

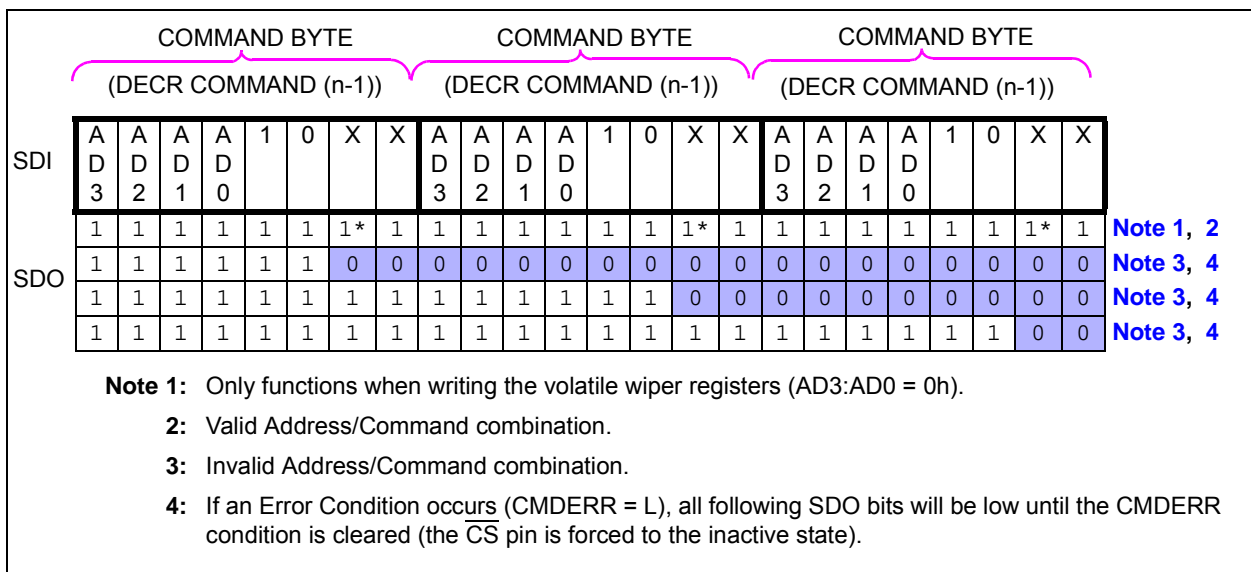

FIGURE 7-9: Continuous Decrement Command – SDI and SDO States.

MCP41HVX1

NOTES:

8.0 APPLICATIONS EXAMPLES

Digital potentiometers have a multitude of practical uses in modern electronic circuits. The most popular uses include precision calibration of set point thresholds, sensor trimming, LCD bias trimming, audio attenuation, adjustable power supplies, motor control overcurrent trip setting, adjustable gain amplifiers and offset trimming.

8.1 Split Rail Applications

Split rail applications are when one device operates from one voltage level (rail) and the second device operates from a second voltage level (rail). The typical scenario will be when the microcontroller is operating at a lower voltage level (for power savings, etc) and the MCP41HVX1 is operating at a higher voltage level to maximize operational performance. This configuration is shown in Figure 8-1.

To ensure that communication properly occurs between the devices, care must be done to verify the compatibility of the V_{IL} , V_{IH} , V_{OL} , V_{OH} levels of the interface signals between the devices. These interface signals are:

- \overline{CS}
- SCK
- SDI
- SDO
- \overline{SHDN}
- \overline{WLAT}

When the microcontroller is at a lower voltage rail, the V_{OH} of the microcontroller needs to be greater than the V_{IH} of the MCP41HVX1, and the V_{IL} of the microcontroller needs to be greater than the V_{OL} of the MCP41HVX1.

Table 8-1 shows the calculated maximum MCP41HVX1 V_L based on the microcontroller's minimum V_{OH} .

Note: V_{OH} specifications typically have a current load specified. This is due to the pin expected to drive externally circuitry. If the pin is unloaded (or lightly loaded), then the V_{OH} of the pin could approach the device V_{DD} (this is dependent on the implementation of the output driver circuit). For V_{OL} , unloaded (or lightly loaded) pins could approach the device V_{SS} . For V_{OH} and V_{OL} characterization graphs from an example microcontroller, see the PIC16F1934 data sheet (DS41364), Figure 31-15 and Figure 31-16.

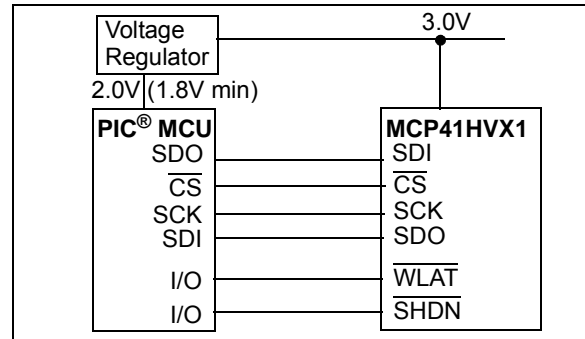

FIGURE 8-1: Example Split Rail System.

TABLE 8-1: MCP41HVX1 V_L VOLTAGE BASED ON MICROCONTROLLER V_{OH}

| V_{DD} (minimum) | PIC [®] MCU V_{OH} (minimum) ⁽¹⁾ | | MCP41HVX1 Max V_L |
|--------------------|--|------------|---------------------|
| | Formula (with load) | Calculated | |
| 1.8V | $0.7 * V_{DD}$ | 1.26V | 2.8V |
| | $0.8 * V_{DD}$ | 1.44V | 3.2V |
| | $0.85 * V_{DD}$ | 1.53V | 3.4V |
| | $0.9 * V_{DD}$ | 1.62V | 3.6V |
| | V_{DD} | 1.8V | 4.0V |
| | $V_{DD} - 0.7V$ | 1.1V | 2.44V |
| 2.7V | $0.7 * V_{DD}$ | 1.89V | 4.2V |
| | $0.8 * V_{DD}$ | 2.16V | 4.8V |
| | $0.9 * V_{DD}$ | 2.43V | 5.4V |
| | V_{DD} | 2.7V | 5.5V |

- Note 1:** The V_{OH} minimum voltage is determined by the load on the pin. If the load is small, a typical output's voltage should approach the device's V_{DD} voltage. This is dependent on the device's output driver design.
- 2:** Split Rail voltages are dependent on V_{IL} , V_{IH} , V_{OL} , and V_{OH} of the microcontroller and the MCP41HVX1 devices.

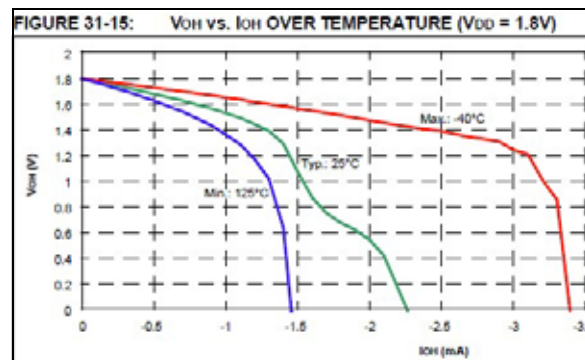

FIGURE 8-2: Example PIC[®] Microcontroller V_{OH} Characterization Graph ($V_{DD} = 1.8V$).

MCP41HVX1

8.2 Using Shutdown Modes

Figure 8-3 shows a possible application circuit where the independent terminals could be used. Disconnecting the wiper allows the transistor input to be taken to the bias voltage level (disconnecting A and or B may be desired to reduce system current). Disconnecting Terminal A modifies the transistor input by the R_{BW} rheostat value to the Common B. Disconnecting Terminal B modifies the transistor input by the R_{AW} rheostat value to the Common A. The Common A and Common B connections could be connected to $V+$ and $V-$.



FIGURE 8-3: Example Application Circuit using Terminal Disconnects.

8.3 High-Voltage DAC

A high-voltage DAC can be implemented using the MCP41HVXX, with voltages as high as 36V. The circuit is shown in Figure 8-4. The equation to calculate the voltage output is shown in Figure 8-1.

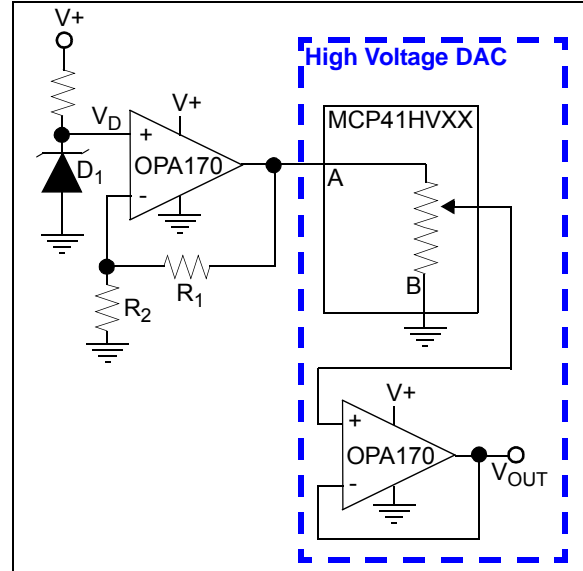

FIGURE 8-4: High Voltage DAC.

EQUATION 8-1: DAC OUTPUT VOLTAGE CALCULATION

8-bit

$$V_{OUT(N)} = \frac{N}{255} \times (V_D \times (1 + \frac{R1}{R2}))$$

N = 0 to 255 (decimal)

7-bit

$$V_{OUT(N)} = \frac{N}{127} \times (V_D \times (1 + \frac{R1}{R2}))$$

N = 0 to 127 (decimal)

8.4 Variable Gain Instrumentation Amplifier

A variable gain instrumentation amplifier can be implemented using the MCP41HVXX along with a high voltage dual analog switch and a high voltage instrumentation amplifier.

Figure 8-4. The equation to calculate the voltage output is shown in Figure 8-1.

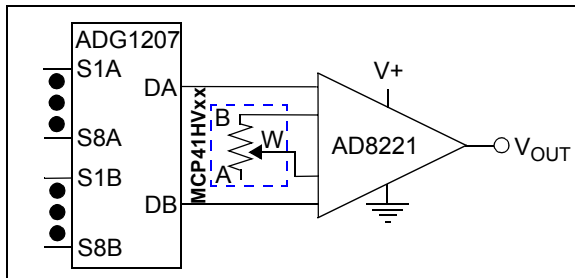

FIGURE 8-5: Variable Gain Instrumentation Amplifier for Data Acquisition System.

EQUATION 8-2: DAC OUTPUT VOLTAGE CALCULATION

8-bit

$$\text{Gain}(N) = 1 + \frac{49.4 \text{ k}\Omega}{(N / 255) \times R_{AB}}$$

N = 0 to 255 (decimal)

7-bit

$$\text{Gain}(N) = 1 + \frac{49.4 \text{ k}\Omega}{(N / 127) \times R_{AB}}$$

N = 0 to 127 (decimal)

8.5 Audio Volume Control

A digital volume control can be implemented with the MCP41HVXX. Figure 8-6 shows a simple audio volume control implementation.

Figure 8-7 shows a circuit-referenced voltage detect circuit. The output of this circuit could be used to control the Wiper Latch of the MCP41HVXX device in the Audio Volume control circuit to reduce zipper noise or to update the different channels at the same time.

The op amp (U1) could be an MCP6001, while the general purpose comparators (U2 and U3) could be an MCP6541. U4 is a simple AND gate.

U1 establishes the signal zero reference. The upper limit of the comparator is set above its offset. The WLAT pin is forced high whenever the voltage falls between 2.502V and 2.497V (a 0.005V window).

The capacitor C1 AC couples the V_{IN} signal into the circuit, before feeding into the windowed comparator (and MCP41HVXX Terminal A pin).

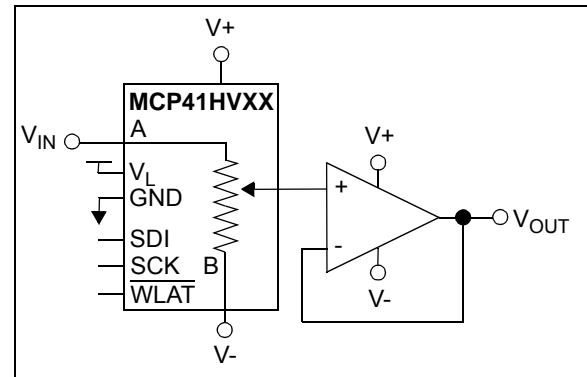

FIGURE 8-6: Audio Volume Control.

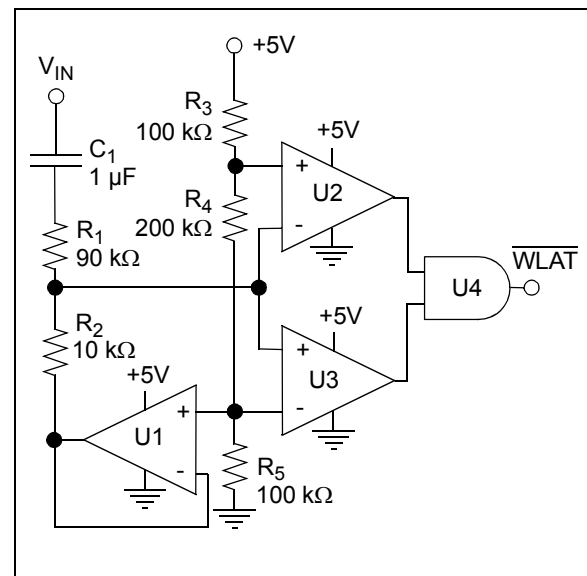

FIGURE 8-7: Referenced Voltage Crossing Detect.

MCP41HVX1

8.6 Programmable Power Supply

The ADP1611 is a step-up DC-to-DC switching converter. Using the MCP41HVXX device allows the power supply to be programmable up to 20V. Figure 8-7 shows a programmable power supply implementation.

Equation 8-3 shows the equation to calculate the output voltage of the programmable power supply. This output is derived from the R_{BW} resistance of the MCP41HVXX device and the R_2 resistor. The ADP1611 will adjust its output voltage to maintain 1.23V on the FB pin.

When power is connected, L1 acts as a short, and V_{OUT} is a diode drop below the +5V voltage. The V_{OUT} voltage will ramp to the programmed value.

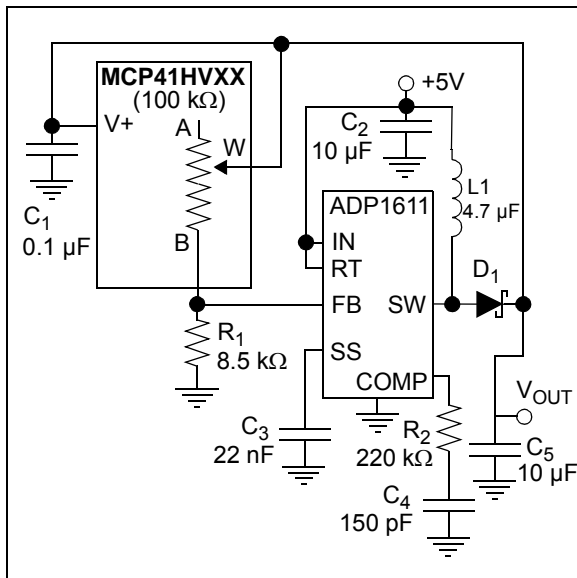

FIGURE 8-8: Programmable Power Supply.

EQUATION 8-3: POWER SUPPLY OUTPUT VOLTAGE CALCULATION

| | |
|--------------|--|
| 8-bit | $V_{OUT(N)} = 1.23V \times \left(1 + \left(\frac{N * R_{AB}}{255} \right) \right)$ |
| | N = 0 to 255 (decimal) |
| ----- | |
| 7-bit | $V_{OUT(N)} = 1.23V \times \left(1 + \left(\frac{N * R_{AB}}{127} \right) \right)$ |
| | N = 0 to 127 (decimal) |

8.7 Programmable Bidirectional Current Source

A programmable bidirectional current source can be implemented with the MCP41HVXX. Figure 8-9 shows an implementation where U1 and U2 work together to deliver the desired current (dependent on selected device) in both directions. The circuit is symmetrical ($R_{1A} = R_{1B}$, $R_{2A} = R_{2B}$, $R_{3A} = R_{3B}$) in order to improve stability. If the resistors are matched, the load current (I_L) calculation is shown below:

EQUATION 8-4: LOAD CURRENT (I_L)

$$I_L = \frac{(R_{2A} + R_{3A})}{R_{1A} * R_{3A}} \times V_W$$

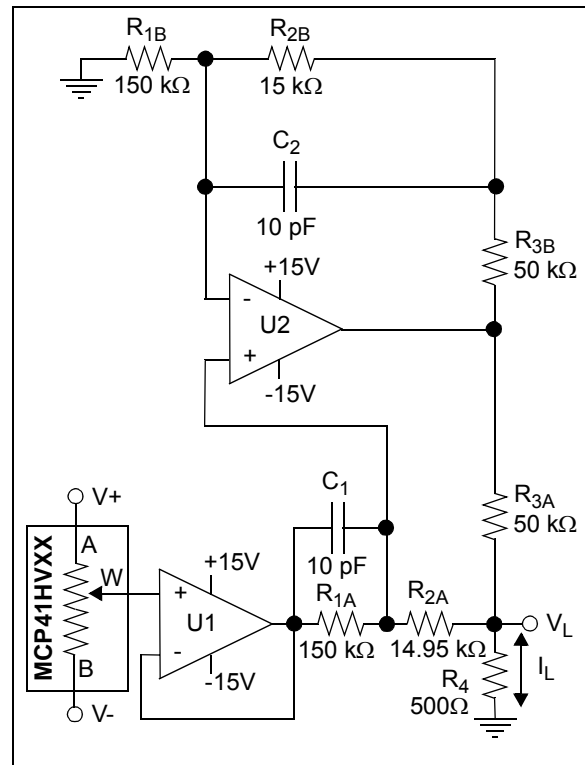

FIGURE 8-9: Programmable Bidirectional Current Source.

8.8 LCD Contrast Control

The MCP41HVXX can be used for LCD contrast control. Figure 8-10 shows a simple programmable LCD contrast control implementation.

Some LCD panels support a fixed power supply of up to 28V. The high voltage digital potentiometer's wiper can support contrast adjustments through the entire voltage range.



FIGURE 8-10: Programmable Contrast Control.

8.9 Serial Interface Communication Times

Table 8-2 shows the time for each SPI serial interface command as well as the effective data update rate that can be supported by the digital interface (based on the two SPI serial interface frequencies). So, the Serial Interface performance, along with the wiper response time, would be used to determine your application's volatile Wiper register update rate.

TABLE 8-2: SERIAL INTERFACE TIMES / FREQUENCIES

| Command | # of Serial Interface bits | Example | | Command Time (μ s) | | Effective Data Update Frequency (kHz) ⁽²⁾ | |
|------------------------|----------------------------|---------------------|----------------------------|-------------------------|-------|--|-----------|
| | | # Bytes Transferred | # of Serial Interface bits | 1MHz | 10MHz | 1MHz | 10MHz |
| Write Single Byte | 16 | 1 | 16 | 16 | 1.6 | 62,500 | 625,000 |
| Write Continuous Bytes | N * 16 | 5 | 80 | 80 | 8 | 12,500 | 125,000 |
| Read Byte | 16 | 1 | 16 | 16 | 1.6 | 62,500 | 625,000 |
| Read Continuous Bytes | N * 16 | 5 | 80 | 80 | 8 | 12,500 | 125,000 |
| Increment Wiper | 8 | 1 | 8 | 8 | 0.8 | 125,000 | 1,250,000 |
| Continuous Increments | N * 8 | 5 | 40 | 40 | 4 | 25,000 | 250,000 |
| Decrement Wiper | 8 | 1 | 8 | 8 | 0.8 | 125,000 | 1,250,000 |
| Continuous Decrements | N * 8 | 5 | 40 | 40 | 4 | 25,000 | 250,000 |

Note 1: Includes the Start or Stop bits.

2: This is the command frequency multiplied by the number of bytes transferred.

MCP41HVX1

8.10 Design Considerations

In the design of a system with the MCP41HVX1 devices, the following considerations should be taken into account:

- **Power Supply Considerations**
- **Layout Considerations**

8.10.1 POWER SUPPLY CONSIDERATIONS

The typical application will require a bypass capacitor in order to filter high-frequency noise, which can be induced onto the power supply's traces. The bypass capacitor helps to minimize the effect of these noise sources on signal integrity. **Figure 8-11** illustrates an appropriate bypass strategy.

In this example, the recommended bypass capacitor value is 0.1 μF . This capacitor should be placed as close (within 4 mm) to the device power pin (V_L) as possible.

The power source supplying these devices should be as clean as possible. If the application circuit has separate digital and analog power supplies, V_+ and V_- should reside on the analog plane.

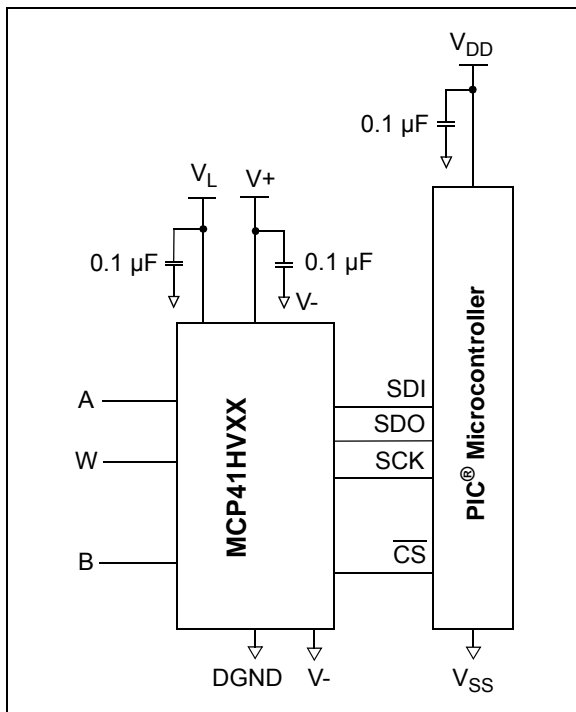

FIGURE 8-11: Typical Microcontroller Connections.

8.10.2 LAYOUT CONSIDERATIONS

In the design of a system with the MCP41HVX1 devices, the following layout considerations should be taken into account:

- **Noise**
- **PCB Area Requirements**
- **Power Dissipation**

8.10.2.1 Noise

Inductively-coupled AC transients and digital switching noise can degrade the input and output signal integrity, potentially masking the MCP41HVX1's performance. Careful board layout minimizes these effects and increases the Signal-to-Noise Ratio (SNR). Multi-layer boards utilizing a low-inductance ground plane, isolated inputs, isolated outputs and proper decoupling are critical to achieving the performance that the silicon is capable of providing. Particularly harsh environments may require shielding of critical signals.

If low noise is desired, breadboards and wire-wrapped boards are not recommended.

8.10.2.2 PCB Area Requirements

In some applications, PCB area is a criteria for device selection. **Table 8-3** shows the package dimensions and area for the different package options. The table also shows the relative area factor compared to the smallest area. For space critical applications, the QFN package would be the suggested package.

TABLE 8-3: PACKAGE FOOTPRINT (1)

| Package | | | Package Footprint | | | |
|---------|-------|------|-------------------|------|-------------------------|---------------|
| Pins | Type | Code | Dimensions (mm) | | Area (mm ²) | Relative Area |
| | | | X | Y | | |
| 14 | TSSOP | ST | 5.10 | 6.40 | 32.64 | 1.31 |
| 20 | QFN | MQ | 5.00 | 5.00 | 25.00 | 1 |

Note 1: Does not include recommended land pattern dimensions.

8.10.3 RESISTOR TEMPCO

Characterization curves of the resistor temperature coefficient (Tempco) are shown in the device characterization graphs.

These curves show that the resistor network is designed to correct for the change in resistance as temperature increases. This technique reduces the end-to-end change in R_{AB} resistance.

8.10.3.1 Power Dissipation

The power dissipation of the high-voltage digital potentiometer will most likely be determined by the power dissipation through the resistor networks.

Table 8-4 shows the power dissipation through the resistor ladder (R_{AB}) when Terminal A = +18V and Terminal B = -18V. This is not the worst case power dissipation based on the 25 mA terminal current specification. Table 8-4 show the worst case current (per resistor network), which is independent of the R_{AB} value).

TABLE 8-4: R_{AB} POWER DISSIPATION

| R_{AB} Resistance (Ω) | | | $ V_A + V_B $ = (V) | Power (mW) (1) |
|----------------------------------|--------|---------|-----------------------------|----------------------|
| Typical | Min | Max | | |
| 5,000 | 4,000 | 6,000 | 36 | 324 |
| 10,000 | 8,000 | 12,000 | 36 | 162 |
| 50,000 | 40,000 | 60,000 | 36 | 32.4 |
| 100,000 | 80,000 | 120,000 | 36 | 16.2 |

Note 1: Power = $V * I = V^2 / R_{AB(MIN)}$.

TABLE 8-5: R_{BW} POWER DISSIPATION

| R_{AB} (Ω) (Typical) | $ V_W + V_B $ (V) | I_{BW} (2) (mA) | Power (mW) (1) |
|------------------------------------|------------------------|----------------------|-------------------|
| 5,000 | 36 | 25 | 900 |
| 10,000 | 36 | 12.5 | 450 |
| 50,000 | 36 | 6.5 | 234 |
| 100,000 | 36 | 6.5 | 234 |

Note 1: Power = $V * I$.

2: See Electrical Specifications (max I_W).

MCP41HVX1

NOTES:

9.0 DEVICE OPTIONS

9.1 Standard Options

9.1.1 POR/BOR WIPER SETTING

The default wiper setting (mid-scale) is indicated by the customer in three digit suffix: -202, -502, -103 and -503. [Table 9-1](#) indicates the device's default settings.

TABLE 9-1: DEFAULT POR/BOR WIPER SETTING SELECTION

| Typical R_{AB} Value | Package Code | Default POR Wiper Setting | Device Resolution | Wiper Code |
|------------------------|--------------|---------------------------|-------------------|------------|
| 5.0 k Ω | -502 | Mid-scale | 8-bit | 7Fh |
| | | | 7-bit | 3Fh |
| 10.0 k Ω | -103 | Mid-scale | 8-bit | 7Fh |
| | | | 7-bit | 3Fh |
| 50.0 k Ω | -503 | Mid-scale | 8-bit | 7Fh |
| | | | 7-bit | 3Fh |
| 100.0 k Ω | -104 | Mid-scale | 8-bit | 7Fh |
| | | | 7-bit | 3Fh |

9.2 Custom Options

Custom options can be made available.

9.2.1 CUSTOM WIPER VALUE ON POR/BOR EVENT

Customers can specify a custom wiper setting via the NSCAR process.

Note 1: Non-Recurring Engineering (NRE) charges and minimum ordering requirements for custom orders. Please contact Microchip sales for additional information.

2: A custom device will be assigned custom device marking.

MCP41HVX1

NOTES:

10.0 DEVELOPMENT SUPPORT

10.1 Development Tools

Several development tools are available to assist in your design and evaluation of the MCP41HVX1 devices. The currently available tools are shown in [Table 10-1](#).

[Figure 10-1](#) shows how the TSSOP20EV bond-out PCB can be populated to easily evaluate the MCP41HVX1 devices. Evaluation can use the PICKit™ Serial Analyzer to control the position of the volatile Wiper and state of the TCON register.

[Figure 10-2](#) shows how the SOIC14EV bond-out PCB can be populated to evaluate the MCP41HVX1 devices. The use of the PICKit Serial Analyzer would require blue wire since the header H1 is not compatibly connected.

These boards may be purchased directly from the Microchip web site at www.microchip.com.

10.2 Technical Documentation

Several additional technical documents are available to assist you in your design and development. These technical documents include Application Notes, Technical Briefs, and Design Guides. [Table 10-2](#) shows some of these documents.

TABLE 10-1: DEVELOPMENT TOOLS

| Board Name | Part # | Comment |
|--|-----------|--|
| 20-pin TSSOP and SSOP Evaluation Board | TSSOP20EV | Can easily interface to PICKit Serial Analyzer (Order #: DV164122) |
| 14-pin SOIC/TSSOP/DIP Evaluation Board | SOIC14EV | |

TABLE 10-2: TECHNICAL DOCUMENTATION

| Application Note Number | Title | Literature # |
|-------------------------|--|--------------|
| TB3073 | Implementing a 10-bit Digital Potentiometer with an 8-bit Digital Potentiometer | DS93073 |
| AN1316 | Using Digital Potentiometers for Programmable Amplifier Gain | DS01316 |
| AN1080 | Understanding Digital Potentiometers Resistor Variations | DS01080 |
| AN737 | Using Digital Potentiometers to Design Low-Pass Adjustable Filters | DS00737 |
| AN692 | Using a Digital Potentiometer to Optimize a Precision Single Supply Photo Detect | DS00692 |
| AN691 | Optimizing the Digital Potentiometer in Precision Circuits | DS00691 |
| AN219 | Comparing Digital Potentiometers to Mechanical Potentiometers | DS00219 |
| — | Digital Potentiometer Design Guide | DS22017 |
| — | Signal Chain Design Guide | DS21825 |
| — | Analog Solutions for Automotive Applications Design Guide | DS01005 |

MCP41HVX1



FIGURE 10-1: Digital Potentiometer Evaluation Board Circuit Using TSSOP20EV.

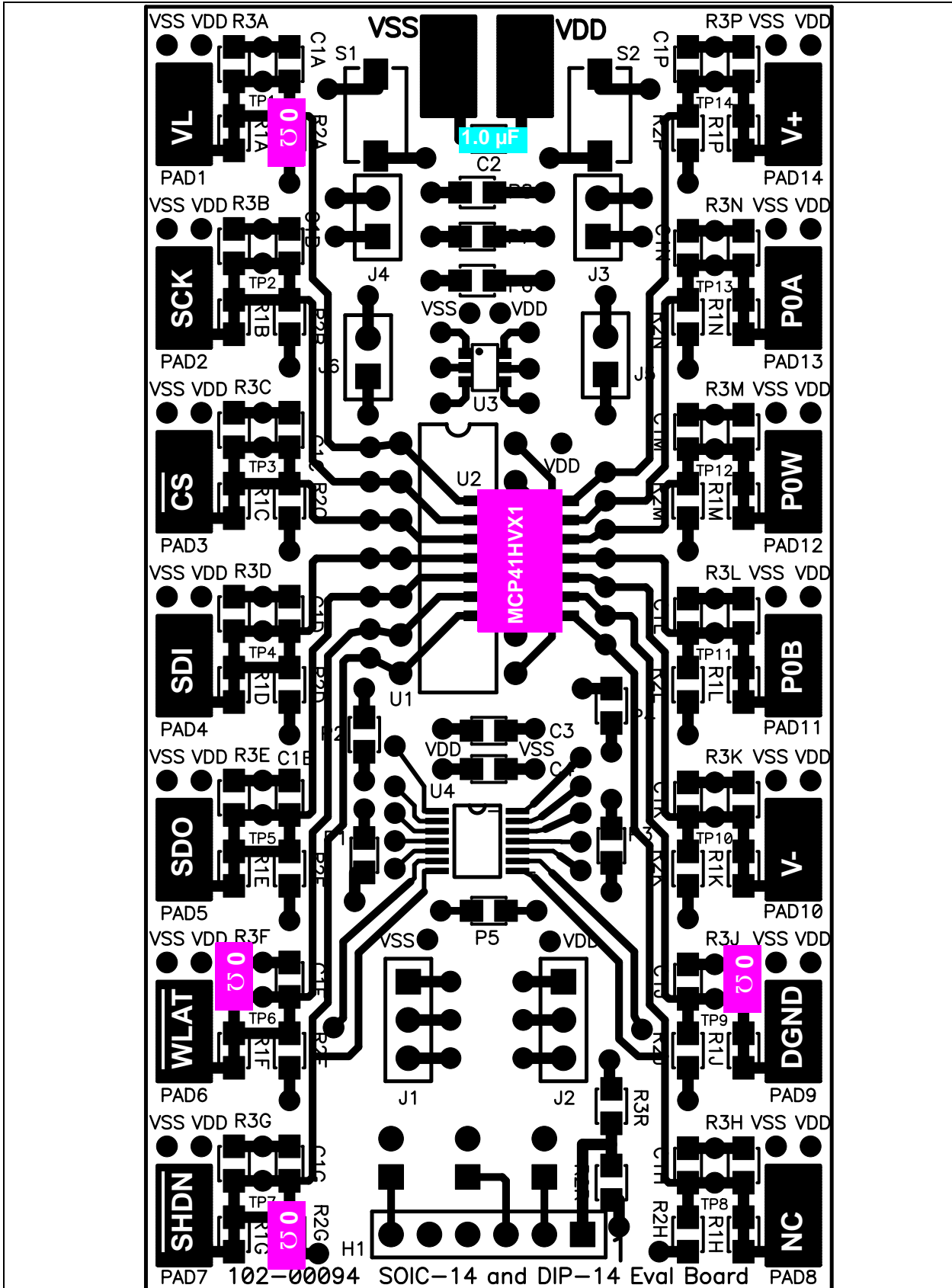

FIGURE 10-2: Digital Potentiometer Evaluation Board Circuit Using SOIC14EV.

MCP41HVX1

NOTES:

11.0 PACKAGING INFORMATION

11.1 Package Marking Information

14-Lead TSSOP (4.4 mm)



Example

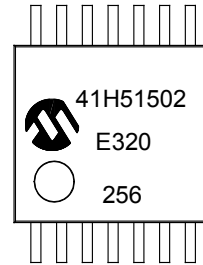

| Part Number | Code | Part Number | Code |
|-------------------|----------|-------------------|----------|
| MCP41HV51-502E/ST | 41H51502 | MCP41HV31-502E/ST | 41H31502 |
| MCP41HV51-103E/ST | 41H51103 | MCP41HV31-103E/ST | 41H31103 |
| MCP41HV51-503E/ST | 41H51503 | MCP41HV31-503E/ST | 41H31503 |
| MCP41HV51-104E/ST | 41H51104 | MCP41HV31-104E/ST | 41H31104 |

20-Lead QFN (5x5x0.9 mm)

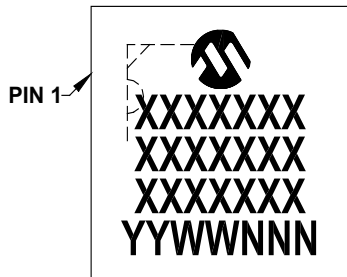

Example

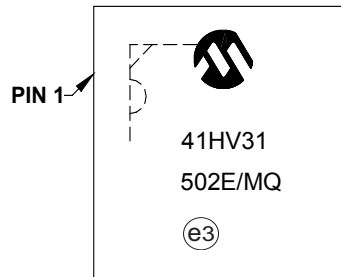

| Part Number | Code | Part Number | Code |
|-------------------|---------|-------------------|---------|
| MCP41HV51-502E/MQ | 502E/MQ | MCP41HV31-502E/MQ | 502E/MQ |
| MCP41HV51-103E/MQ | 103E/MQ | MCP41HV31-103E/MQ | 103E/MQ |
| MCP41HV51-503E/MQ | 503E/MQ | MCP41HV31-503E/MQ | 503E/MQ |
| MCP41HV51-104E/MQ | 104E/MQ | MCP41HV31-104E/MQ | 104E/MQ |

Legend:

- XX...X Customer-specific information
- Y Year code (last digit of calendar year)
- YY Year code (last 2 digits of calendar year)
- WW Week code (week of January 1 is week '01')
- NNN Alphanumeric traceability code
- (e3) RoHS Compliant JEDEC designator for Matte Tin (Sn)
- * This package is RoHS Compliant. The RoHS Compliant JEDEC designator (e3) can be found on the outer packaging for this package.

Note: In the event the full Microchip part number cannot be marked on one line, it will be carried over to the next line, thus limiting the number of available characters for customer-specific information.

MCP41HVX1

14-Lead Plastic Thin Shrink Small Outline (ST) - 4.4 mm Body [TSSOP]

Note: For the most current package drawings, please see the Microchip Packaging Specification located at <http://www.microchip.com/packaging>



Microchip Technology Drawing C04-087C Sheet 1 of 2

14-Lead Plastic Thin Shrink Small Outline (ST) - 4.4 mm Body [TSSOP]

Note: For the most current package drawings, please see the Microchip Packaging Specification located at <http://www.microchip.com/packaging>

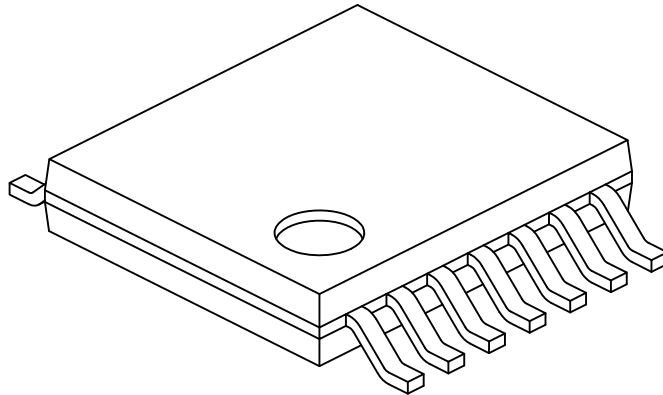

| Units | | MILLIMETERS | | |
|--------------------------|-----------|-------------|------|------|
| Dimension Limits | | MIN | NOM | MAX |
| Number of Pins | N | 14 | | |
| Pitch | e | 0.65 BSC | | |
| Overall Height | A | - | - | 1.20 |
| Molded Package Thickness | A2 | 0.80 | 1.00 | 1.05 |
| Standoff | A1 | 0.05 | - | 0.15 |
| Overall Width | E | 6.40 BSC | | |
| Molded Package Width | E1 | 4.30 | 4.40 | 4.50 |
| Molded Package Length | D | 4.90 | 5.00 | 5.10 |
| Foot Length | L | 0.45 | 0.60 | 0.75 |
| Footprint | (L1) | 1.00 REF | | |
| Foot Angle | φ | 0° | - | 8° |
| Lead Thickness | c | 0.09 | - | 0.20 |
| Lead Width | b | 0.19 | - | 0.30 |

Notes:

- Pin 1 visual index feature may vary, but must be located within the hatched area.
- Dimensions D and E1 do not include mold flash or protrusions. Mold flash or protrusions shall not exceed 0.15mm per side.
- Dimensioning and tolerancing per ASME Y14.5M

BSC: Basic Dimension. Theoretically exact value shown without tolerances.

REF: Reference Dimension, usually without tolerance, for information purposes only.

Microchip Technology Drawing No. C04-087C Sheet 2 of 2

MCP41HVX1

14-Lead Plastic Thin Shrink Small Outline (ST) - 4.4 mm Body [TSSOP]

Note: For the most current package drawings, please see the Microchip Packaging Specification located at <http://www.microchip.com/packaging>



RECOMMENDED LAND PATTERN

| Dimension Limits | Units | MILLIMETERS | | |
|--------------------------|-------|-------------|------|------|
| | | MIN | NOM | MAX |
| Contact Pitch | E | 0.65 BSC | | |
| Contact Pad Spacing | C1 | | 5.90 | |
| Contact Pad Width (X14) | X1 | | | 0.45 |
| Contact Pad Length (X14) | Y1 | | | 1.45 |
| Distance Between Pads | G | 0.20 | | |

Notes:

1. Dimensioning and tolerancing per ASME Y14.5M

BSC: Basic Dimension. Theoretically exact value shown without tolerances.

Microchip Technology Drawing No. C04-2087A

MCP41HVX1

20-Lead Plastic Quad Flat, No Lead Package (ML) – 4x4x0.9 mm Body [QFN]

Note: For the most current package drawings, please see the Microchip Packaging Specification located at <http://www.microchip.com/packaging>

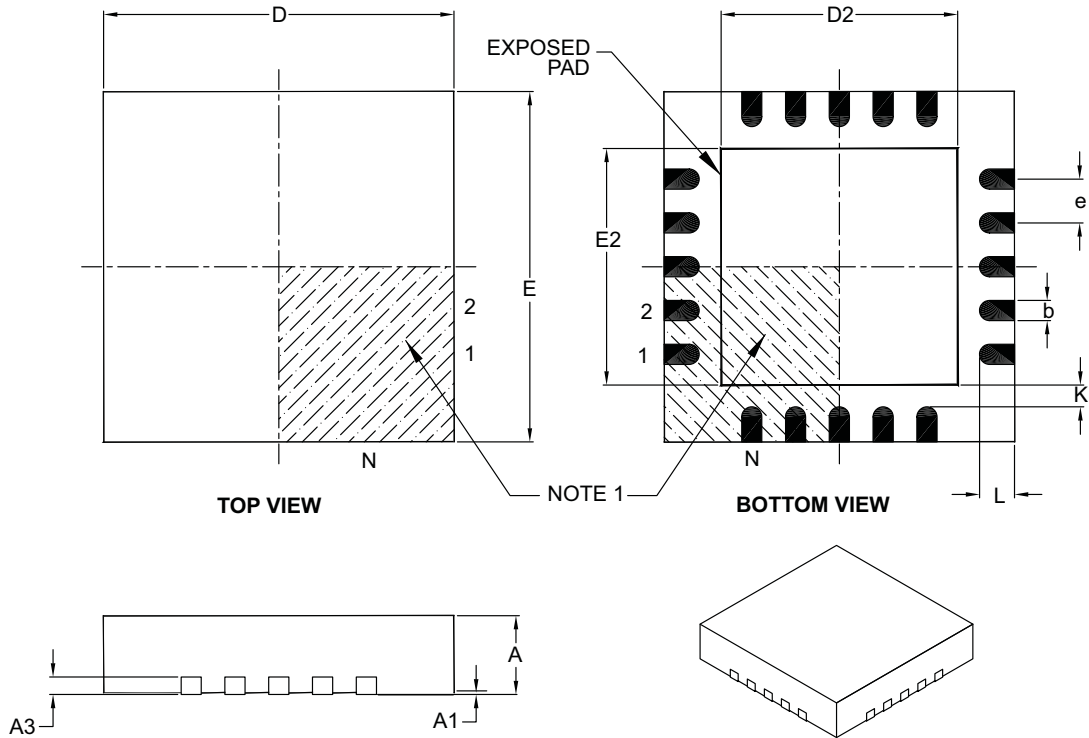

| Dimension Limits | Units | MILLIMETERS | | |
|------------------------|-------|-------------|------|------|
| | | MIN | NOM | MAX |
| Number of Pins | N | 20 | | |
| Pitch | e | 0.50 BSC | | |
| Overall Height | A | 0.80 | 0.90 | 1.00 |
| Standoff | A1 | 0.00 | 0.02 | 0.05 |
| Contact Thickness | A3 | 0.20 REF | | |
| Overall Width | E | 4.00 BSC | | |
| Exposed Pad Width | E2 | 2.60 | 2.70 | 2.80 |
| Overall Length | D | 4.00 BSC | | |
| Exposed Pad Length | D2 | 2.60 | 2.70 | 2.80 |
| Contact Width | b | 0.18 | 0.25 | 0.30 |
| Contact Length | L | 0.30 | 0.40 | 0.50 |
| Contact-to-Exposed Pad | K | 0.20 | – | – |

Notes:

- Pin 1 visual index feature may vary, but must be located within the hatched area.
- Package is saw singulated.
- Dimensioning and tolerancing per ASME Y14.5M.

BSC: Basic Dimension. Theoretically exact value shown without tolerances.

REF: Reference Dimension, usually without tolerance, for information purposes only.

Microchip Technology Drawing C04-126B

MCP41HVX1

20-Lead Plastic Quad Flat, No Lead Package (ML) - 4x4 mm Body [QFN]
With 0.40 mm Contact Length

Note: For the most current package drawings, please see the Microchip Packaging Specification located at <http://www.microchip.com/packaging>

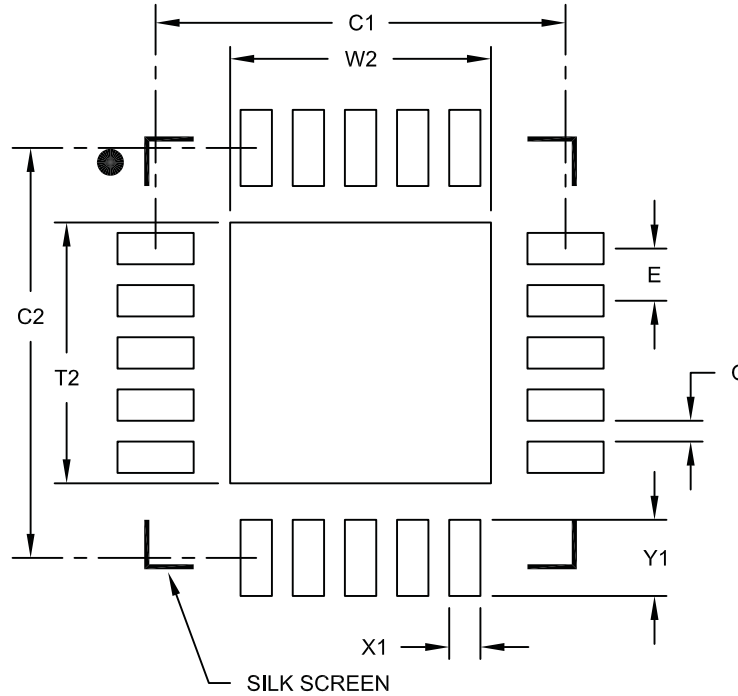

RECOMMENDED LAND PATTERN

| Dimension Limits | Units | MILLIMETERS | | |
|----------------------------|-------|-------------|------|------|
| | | MIN | NOM | MAX |
| Contact Pitch | E | 0.50 BSC | | |
| Optional Center Pad Width | W2 | | | 2.50 |
| Optional Center Pad Length | T2 | | | 2.50 |
| Contact Pad Spacing | C1 | | 3.93 | |
| Contact Pad Spacing | C2 | | 3.93 | |
| Contact Pad Width | X1 | | | 0.30 |
| Contact Pad Length | Y1 | | | 0.73 |
| Distance Between Pads | G | 0.20 | | |

Notes:

1. Dimensioning and tolerancing per ASME Y14.5M

BSC: Basic Dimension. Theoretically exact value shown without tolerances.

Microchip Technology Drawing No. C04-2126A

APPENDIX A: REVISION HISTORY

Revision A (May 2013)

- Original Release of this Document.

APPENDIX B: TERMINOLOGY

This appendix discusses the terminology used in this document as well as describes how a parameter is measured.

B.1 Potentiometer (Voltage Divider)

The potentiometer configuration is when all three terminals of the device are tied to different nodes in the circuit. This allows the potentiometer to output a voltage proportional to the input voltage. This configuration is sometimes called voltage divider mode. The potentiometer is used to provide a variable voltage by adjusting the wiper position between the two endpoints as shown in [Figure B-1](#). Reversing the polarity of the A and B terminals will not affect operation.

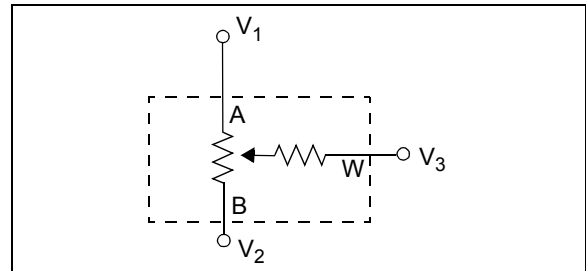

FIGURE B-1: POTENTIOMETER CONFIGURATION.

The temperature coefficient of the R_{AB} resistors is minimal by design. In this configuration, the resistors all change uniformly, so minimal variation should be seen.

B.2 Rheostat (Variable Resistor)

The rheostat configuration is when two of the three digital potentiometer's terminals are used as a resistive element in the circuit. With terminal W (wiper) and either terminal A or terminal B, a variable resistor is created. The resistance will depend on the tap setting of the wiper (and the wiper's resistance). The resistance is controlled by changing the wiper setting. [Figure B-2](#) shows the two possible resistors that can be used. Reversing the polarity of the A and B terminals will not affect operation.

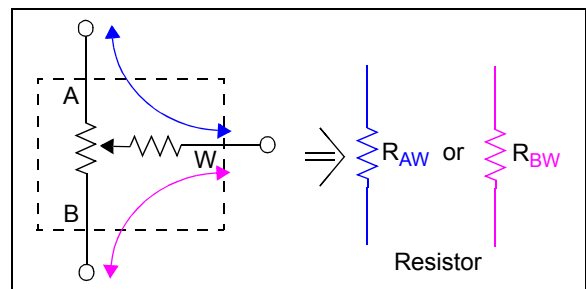

FIGURE B-2: RHEOSTAT CONFIGURATION.

MCP41HVX1

B.3 Resolution

The resolution is the number of Wiper output states that divide the full-scale range. For the 8-bit digital potentiometer, the resolution is 2^8 , meaning the digital potentiometer Wiper code ranges from 0 to 255.

B.4 Step Resistance (R_S)

The resistance Step size (R_S) equates to one LSB of the resistor ladder. Equation B-1 shows the calculation for the step resistance (R_S).

EQUATION B-1: R_S CALCULATION

Ideal

$$R_{S(Ideal)} = \frac{R_{AB}}{2^N - 1} \quad \text{or} \quad \frac{(V_A - V_B) / I_{AB}}{2^N - 1}$$

Measured

$$R_{S(Measured)} = \frac{(V_{W(@FS)} - V_{W(@ZS)}) / I_{AB}}{2^N - 1}$$

where:

$$2^N - 1 = 255 \text{ (MCP41HV51/61)}$$

$$= 127 \text{ (MCP41HV31/41)}$$

V_A = Voltage on Terminal A pin

V_B = Voltage on Terminal B pin

I_{AB} = Measured Current through A and B pins

$V_{W(@FS)}$ = Measured Voltage on W pin at Full-Scale code (FFh or 7Fh)

$V_{W(@ZS)}$ = Measured Voltage on W pin at Zero-Scale code (00h)

B.5 Wiper Resistance

Wiper resistance is the series resistance of the analog switch that connects the selected resistor ladder node to the Wiper Terminal common signal (see Figure 5-1).

A value in the volatile wiper register selects which analog switch to close, connecting the W terminal to the selected node of the resistor ladder.

The resistance is dependent on the voltages on the analog switch source, gate, and drain nodes, as well as the device's wiper code, temperature, and the current through the switch. As the device voltage decreases, the wiper resistance increases.

The wiper resistance is measured by forcing a current through the W and B terminals (I_{WB}) and measuring the voltage on the W and A terminals (V_W and V_A). Equation B-2 shows how to calculate this resistance.

EQUATION B-2: R_W CALCULATION

$$R_{W(Measured)} = \frac{(V_W - V_A)}{I_{WB}}$$

where:

V_A = Voltage on Terminal A pin

V_W = Voltage on Terminal W pin

I_{WB} = Measured current through W and B pins

The wiper resistance in potentiometer-generated voltage divider applications is not a significant source of error (it does not effect the output voltage seen on the W pin).

The wiper resistance in rheostat applications can create significant nonlinearity as the wiper is moved toward zero scale (00h). The lower the nominal resistance, the greater the possible error.

B.6 R_{ZS} Resistance

The analog switch between the resistor ladder and the Terminal B pin introduces a resistance, which we call the Zero-Scale resistance (R_{ZS}). Equation B-3 shows how to calculate this resistance.

EQUATION B-3: R_{ZS} CALCULATION

$$R_{ZS(Measured)} = \frac{(V_{W(@ZS)} - V_B)}{I_{AB}}$$

where:

$V_{W(@ZS)}$ = Voltage on Terminal W pin at Zero-Scale wiper code

V_B = Voltage on Terminal B pin

I_{WB} = Measured Current through A and B pins

B.7 R_{FS} Resistance

The analog switch between the resistor ladder and the Terminal A pin introduces a resistance, which we call the Full-Scale resistance (R_{FS}). Equation B-4 shows how to calculate this resistance.

EQUATION B-4: R_{FS} CALCULATION

$$R_{FS(Measured)} = \frac{(V_A - V_{W(@FS)})}{I_{AB}}$$

where:

V_A = Voltage on Terminal A pin

$V_{W(@FS)}$ = Voltage on Terminal W pin at Full-Scale wiper code

I_{WB} = Measured Current through A and B pins

B.8 Least Significant Bit (LSb)

This is the difference between two successive codes (either in resistance or voltage). For a given output range it is divided by the resolution of the device (Equation B-5).

EQUATION B-5: LSb CALCULATION

Ideal

$$LSb(Ideal) = \frac{\text{In Resistance } R_{AB}}{2^N - 1} = \frac{\text{In Voltage } V_A - V_B}{2^N - 1}$$

Measured

$$LSb(Measured) = \frac{(V_{W(@FS)} - V_{W(@ZS)}) / I_{AB}}{2^N - 1} = \frac{V_{W(@FS)} - V_{W(@ZS)}}{2^N - 1}$$

where:

- $2^N - 1 = 255$ (MCP41HV51/61)
- $= 127$ (MCP41HV31/41)
- V_A = Voltage on Terminal A pin
- V_B = Voltage on Terminal B pin
- V_{AB} = Measured Voltage between A and B pins
- I_{AB} = Measured Current through A and B pins
- $V_{W(@FS)}$ = Measured Voltage on W pin at Full-Scale code (FFh or 7Fh)
- $V_{W(@ZS)}$ = Measured Voltage on W pin at Zero-Scale code (00h)

B.9 Monotonic Operation

Monotonic operation means that the device's output (resistance (R_{BW}) or voltage (V_W)) increases with every one code step (LSb) increment of the wiper register.



FIGURE B-3: THEORETICAL V_W OUTPUT VS CODE (MONOTONIC OPERATION).

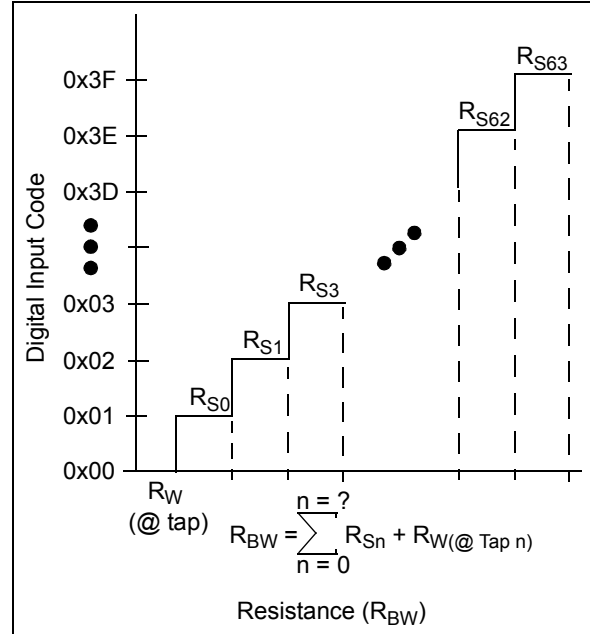

FIGURE B-4: THEORETICAL R_{BW} OUTPUT VS CODE (MONOTONIC OPERATION).

MCP41HVX1

B.10 Full-Scale Error (E_{FS})

The Full-Scale Error (see [Figure B-5](#)) is the error of the V_W pin relative to the expected V_W voltage (theoretical) for the maximum device Wiper register code (code FFh for 8-bit and code 7Fh for 7-bit), see [Equation B-6](#). The error is dependent on the resistive load on the V_{OUT} pin (and where that load is tied to, such as V_{SS} or V_{DD}). For loads (to V_{SS}) greater than specified, the full scale error will be greater.

The error in bits is determined by the theoretical voltage step size to give an error in LSB.

Note: Analog switch leakage increases with temperature. This leakage increase substantially at higher temperatures (> ~100°C). As analog switch leakage increases, the Full-Scale output value decreases, which increases the Full-Scale Error.

EQUATION B-6: FULL-SCALE ERROR

$$E_{FS} = \frac{V_{W(@FS)} - V_A}{V_{LSb(IDEAL)}}$$

Where:

E_{FS} is expressed in LSB

$V_{W(@FS)}$ is the V_W voltage when the Wiper register code is at Full-scale.

$V_{IDEAL(@FS)}$ is the ideal output voltage when the Wiper register code is at Full-scale.

$V_{LSb(IDEAL)}$ is the theoretical voltage step size.

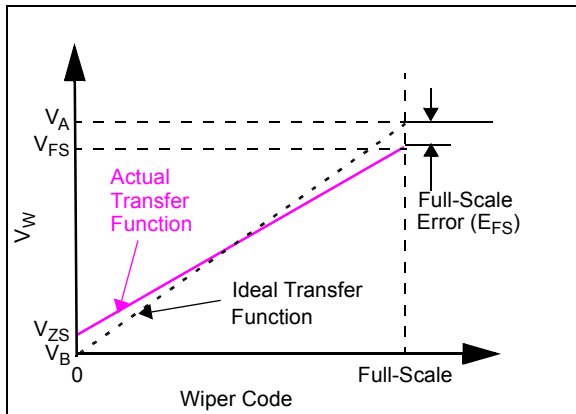

FIGURE B-5: FULL-SCALE ERROR EXAMPLE.

B.11 Zero-Scale Error (E_{ZS})

The Zero-Scale Error (see [Figure B-6](#)) is the difference between the ideal and measured V_{OUT} voltage with the Wiper register code equal to 00h ([Equation B-7](#)). The error is dependent on the resistive load on the V_{OUT} pin (and where that load is tied to, such as V_{SS} or V_{DD}). For loads (to V_{DD}) greater than specified, the zero scale error will be greater.

The error in bits is determined by the theoretical voltage step size to give an error in LSB.

Note: Analog switch leakage increases with temperature. This leakage increase substantially at higher temperatures (> ~100°C). As analog switch leakage increases the Zero-Scale output value decreases, which decreases the Zero-Scale Error.

EQUATION B-7: ZERO SCALE ERROR

$$E_{ZS} = \frac{V_{W@ZS}}{V_{LSb(IDEAL)}}$$

Where:

E_{FS} is expressed in LSB

$V_{W@ZS}$ is the V_W voltage when the Wiper register code is at Zero-scale.

$V_{LSb(IDEAL)}$ is the theoretical voltage step size.

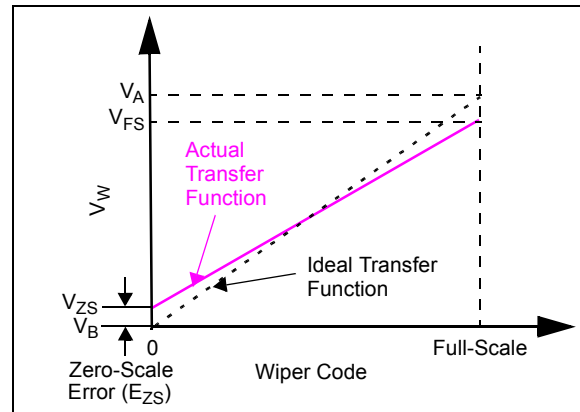

FIGURE B-6: ZERO-SCALE ERROR EXAMPLE.

B.12 Integral Non-linearity (P-INL) Potentiometer Configuration

The Potentiometer Integral nonlinearity (P-INL) error is the maximum deviation of an actual V_W transfer function from an ideal transfer function (straight line).

In the MCP41HVX1, P-INL is calculated using the Zero-Scale and Full-Scale wiper code end points. P-INL is expressed in LSB. P-INL is also called relative accuracy. Equation B-8 shows how to calculate the P-INL error in LSB and Figure B-7 shows an example of P-INL accuracy.

Positive P-INL means higher V_W voltage than ideal. Negative P-INL means lower V_W voltage than ideal.

Note: Analog switch leakage increases with temperature. This leakage increase substantially at higher temperatures (> ~100°C). As analog switch leakage increases, the Wiper output voltage (V_W) decreases, which effects the INL Error.

EQUATION B-8: P-INL ERROR

$$E_{INL} = \frac{(V_{W(@Code)} - (V_{LSb(Measured)} * Code))}{V_{LSb(Measured)}}$$

Where:

INL is expressed in LSB.

Code = Wiper Register Value

$V_{W(@Code)}$ = The measured V_W output voltage with a given Wiper register code

V_{LSb} = For Ideal:
 $V_{AB} / \text{Resolution}$
 For Measured:
 $(V_{W(@FS)} - V_{W(@ZS)}) / 255$

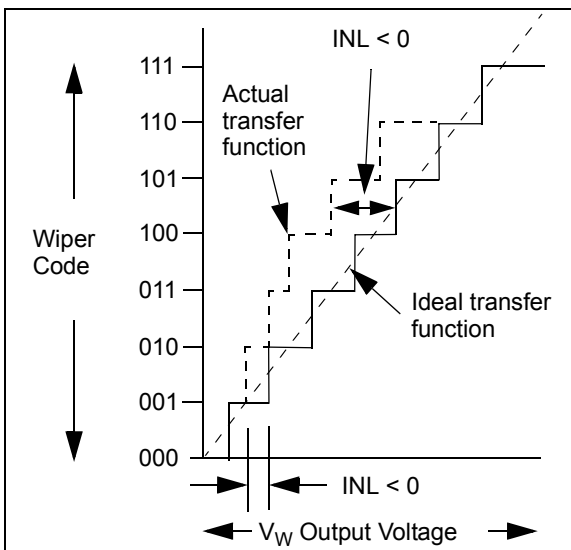

FIGURE B-7: P-INL ACCURACY.

B.13 Differential Nonlinearity (P-DNL) Potentiometer Configuration

The Potentiometer Differential nonlinearity (P-DNL) error (see Figure B-8) is the measure of V_W step size between codes. The ideal step size between codes is 1 LSB. A P-DNL error of zero would imply that every code is exactly 1 LSB wide. If the P-DNL error is less than 1 LSB, the Digital Potentiometer guarantees monotonic output and no missing codes. The P-DNL error between any two adjacent codes is calculated in Equation B-9.

P-DNL error is the measure of variations in code widths from the ideal code width.

Note: Analog switch leakage increases with temperature. This leakage increase substantially at higher temperatures (> ~100°C). As analog switch leakage increases, the Wiper output voltage (V_W) decreases, which effects the DNL Error.

EQUATION B-9: P-DNL ERROR

$$E_{DNL} = \frac{(V_{W(code = n+1)} - V_{W(code = n)}) - V_{LSb(Measured)}}{V_{LSb(Measured)}}$$

Where:

DNL is expressed in LSB.

$V_{W(Code = n)}$ = The measured V_W output voltage with a given Wiper register code.

V_{LSb} = For Ideal:
 $V_{AB} / \text{Resolution}$
 For Measured:
 $(V_{W(@FS)} - V_{W(@ZS)}) / \# \text{ of } R_S$



FIGURE B-8: P-DNL ACCURACY.

MCP41HVX1

B.14 Integral Non-linearity (R-INL) Rheostat Configuration

The Rheostat Integral nonlinearity (R-INL) error is the maximum deviation of an actual R_{BW} transfer function from an ideal transfer function (straight line).

In the MCP41HVX1, INL is calculated using the Zero-Scale and Full-Scale wiper code end points. R-INL is expressed in LSB. R-INL is also called relative accuracy. Equation B-10 shows how to calculate the R-INL error in LSB and Figure B-9 shows an example of R-INL accuracy.

Positive R-INL means higher V_{OUT} voltage than ideal. Negative R-INL means lower V_{OUT} voltage than ideal.

EQUATION B-10: R-INL ERROR

$$E_{INL} = \frac{(R_{BW(@code)} - R_{BW(Ideal)})}{R_{LSb(Ideal)}}$$

Where:
 INL is expressed in LSB.
 $R_{BW(Code = n)}$ = The measured R_{BW} resistance with a given wiper register code
 R_{LSb} = For Ideal:
 $R_{AB} / \text{Resolution}$
 For Measured:
 $R_{BW(@FS)} / \# \text{ of } R_S$



FIGURE B-9: R-INL ACCURACY.

B.15 Differential Nonlinearity (R-DNL) Rheostat Configuration

The Rheostat Differential nonlinearity (R-DNL) error (see Figure B-10) is the measure of R_{BW} step size between codes in actual transfer function. The ideal step size between codes is 1 LSB. A R-DNL error of zero would imply that every code is exactly 1 LSB wide. If the R-DNL error is less than 1 LSB, the R_{BW} Resistance guarantees monotonic output and no missing codes. The R-DNL error between any two adjacent codes is calculated in Equation B-11.

R-DNL error is the measure of variations in code widths from the ideal code width. A R-DNL error of zero would imply that every code is exactly 1 LSB wide.

EQUATION B-11: R-DNL ERROR

$$E_{DNL} = \frac{(V_{OUT(code = n+1)} - V_{OUT(code = n)}) - V_{LSb(Measured)}}{V_{LSb(Measured)}}$$

Where:
 DNL is expressed in LSB.
 $R_{BW(Code = n)}$ = The measured R_{BW} resistance with a given wiper register code
 R_{LSb} = For Ideal:
 $R_{AB} / \text{Resolution}$
 For Measured:
 $R_{BW(@FS)} / \# \text{ of } R_S$

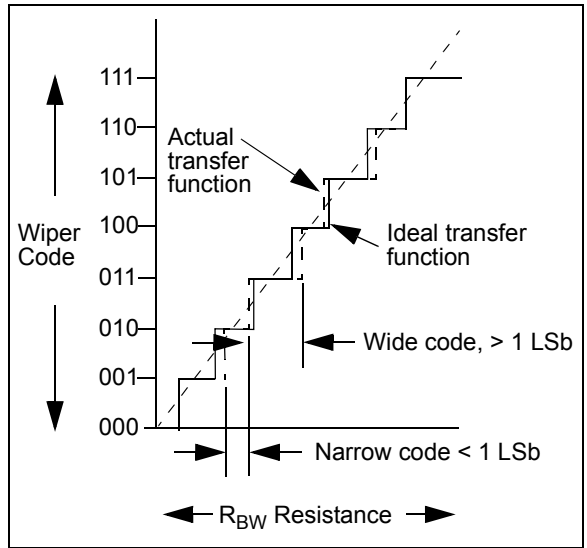

FIGURE B-10: R-DNL ACCURACY.

B.16 Total Unadjusted Error (E_T)

The Total Unadjusted Error (E_T) is the difference between the ideal and measured V_W voltage. Typically, calibration of the output voltage is implemented to improve system performance.

The error in bits is determined by the theoretical voltage step size to give an error in LSb.

Equation B-12 shows the Total Unadjusted Error calculation.

Note: Analog switch leakage increases with temperature. This leakage increase substantially at higher temperatures ($> \sim 100^\circ\text{C}$). As analog switch leakage increases, the Wiper output voltage (V_W) decreases, which effects the total Unadjusted Error.

EQUATION B-12: TOTAL UNADJUSTED ERROR CALCULATION

$$E_T = \frac{(V_{W_Actual}(@code) - V_{W_Ideal}(@Code))}{V_{LSb(Ideal)}}$$

Where:

E_T is expressed in LSb.

$V_{W_Actual}(@code)$ = The measured W pin output voltage at the specified code

$V_{W_Ideal}(@code)$ = The calculated W pin output voltage at the specified code (code * $V_{LSb(Ideal)}$)

$V_{LSb(Ideal)} = V_{AB} / \# R_S$
 8-bit = $V_{AB} / 255$
 7-bit = $V_{AB} / 127$

B.17 Settling Time

The Settling time is the time delay required for the V_W voltage to settle into its new output value. This time is measured from the start of code transition, to when the V_W voltage is within the specified accuracy. It is related to the RC characteristics of the resistor ladder and wiper switches.

In the MCP41HVX1, the settling time is a measure of the time delay until the V_W voltage reaches within 0.5 LSb of its final value, when the volatile Wiper Register changes from Zero Scale to Full Scale (or Full Scale to Zero Scale).

B.18 Major-Code Transition Glitch

Major-code transition glitch is the impulse energy injected into the Wiper pin when the code in the Wiper register changes state. It is normally specified as the area of the glitch in nV-Sec, and is measured when the digital code is changed by 1 LSb at the major carry transition (Example: 01111111 to 10000000, or 10000000 to 01111111).

B.19 Digital Feedthrough

The Digital feedthrough is the glitch that appears at the analog output caused by coupling from the digital input pins of the device. The area of the glitch is expressed in nV-Sec, and is measured with a full-scale change (Example: all 0s to all 1s and vice versa) on the digital input pins. The digital feedthrough is measured when the digital potentiometer is not being written to the output register.

B.20 Power-Supply Sensitivity (PSS)

PSS indicates how the output (V_W or R_{BW}) of the digital potentiometer is affected by changes in the supply voltage. PSS is the ratio of the change in V_W to a change in V_{DD} for mid-scale output of the digital potentiometer. The V_W is measured while the V_{DD} is varied from 5.5V to 2.7V as a step, and expressed in % / %, which is the % change of the V_W output voltage with respect to the % change of the V_{DD} voltage.

EQUATION B-13: PSS CALCULATION

$$PSS = \frac{(V_{W(@5.5V)} - V_{W(@2.7V)}) / V_{W(@5.5V)}}{(5.5V - 2.7V) / 5.5V}$$

Where:

PSS is expressed in % / %.

$V_{W(@5.5V)}$ = The measured V_W output voltage with $V_{DD} = 5.5V$

$V_{W(@2.7V)}$ = The measured V_W output voltage with $V_{DD} = 2.7V$

B.21 Power-Supply Rejection Ratio (PSRR)

PSRR indicates how the output of the digital potentiometer is affected by changes in the supply voltage. PSRR is the ratio of the change in V_W to a change in V_{DD} for full-scale output of the digital potentiometer. The V_W is measured while the V_{DD} is varied +/- 10% (V_A and V_B voltages held constant), and expressed in dB or $\mu\text{V/V}$.

MCP41HVX1

B.22 Ratiometric Temperature Coefficient

The ratiometric temperature coefficient quantifies the error in the ratio R_{AW}/R_{WB} due to temperature drift. This is typically the critical error when using a digital potentiometer in a voltage divider configuration.

B.23 Absolute Temperature Coefficient

The absolute temperature coefficient quantifies the error in the end-to-end resistance (Nominal resistance R_{AB}) due to temperature drift. This is typically the critical error when using the device in an adjustable resistor configuration.

Characterization curves of the resistor temperature coefficient (Tempco) are shown in [Section 2.0 “Typical Performance Curves”](#).

B.24 -3dB Bandwidth

This is the frequency of the signal at the A terminal, that causes the voltage at the W pin to fall -3 dB value from that value of a static value on the A terminal. The output decreases due to the RC characteristics of the resistor network.

B.25 Resistor Noise Density (e_{N_WB})

This is the random noise generated by the device's internal resistances. It is specified as a spectral density (voltage per square root Hertz).

PRODUCT IDENTIFICATION SYSTEM

To order or obtain information, e.g., on pricing or delivery, refer to the factory or the listed sales office.

| <u>PART NO.</u> | <u>XXX</u> | <u>X</u> | <u>/XX</u> |
|----------------------------|------------------------------------|---|------------|
| Device | Resistance Version | Temperature Range | Package |
| Device: | MCP41HV31: | Single Potentiometer (7-bit) with SPI Interface | |
| | MCP41HV31T: | Single Potentiometer (7-bit) with SPI Interface (Tape and Reel) | |
| | MCP41HV51: | Single Potentiometer (8-bit) with SPI Interface | |
| | MCP41HV51T: | Single Potentiometer (8-bit) with SPI Interface (Tape and Reel) | |
| Resistance Version: | 502 = 5 kΩ | | |
| | 103 = 10 kΩ | | |
| | 503 = 50 kΩ | | |
| | 104 = 100 kΩ | | |
| Temperature Range: | E = -40°C to +125°C | | |
| Package: | ST = Plastic TSSOP-14, 14-lead | | |
| | MQ = Plastic QFN-20 (5x5), 20-lead | | |

Examples:

- a) MCP41HV51T-502E/ST
5 kΩ, 8-bit, 14-LD TSSOP.
- b) MCP41HV51T-103E/ST
10 kΩ, 8-bit, 14-LD TSSOP.
- c) MCP41HV31T-503E/ST
50 kΩ, 7-bit, 14-LD TSSOP.
- d) MCP41HV31T-104E/MQ
100 kΩ, 7-bit, 20-LD QFN (5x5).

- a) MCP41HV51T-502E/MQ
5 kΩ, 8-bit, 20-LD QFN (5x5).
- b) MCP41HV51T-103E/MQ
10 kΩ, 8-bit, 20-LD QFN (5x5).
- c) MCP41HV31T-503E/MQ
50 kΩ, 7-bit, 20-LD QFN (5x5).
- d) MCP41HV31T-104E/MQ
100 kΩ, 7-bit, 20-LD QFN (5x5).

MCP41HVX1

NOTES:

Note the following details of the code protection feature on Microchip devices:

- Microchip products meet the specification contained in their particular Microchip Data Sheet.
- Microchip believes that its family of products is one of the most secure families of its kind on the market today, when used in the intended manner and under normal conditions.
- There are dishonest and possibly illegal methods used to breach the code protection feature. All of these methods, to our knowledge, require using the Microchip products in a manner outside the operating specifications contained in Microchip's Data Sheets. Most likely, the person doing so is engaged in theft of intellectual property.
- Microchip is willing to work with the customer who is concerned about the integrity of their code.
- Neither Microchip nor any other semiconductor manufacturer can guarantee the security of their code. Code protection does not mean that we are guaranteeing the product as “unbreakable.”

Code protection is constantly evolving. We at Microchip are committed to continuously improving the code protection features of our products. Attempts to break Microchip's code protection feature may be a violation of the Digital Millennium Copyright Act. If such acts allow unauthorized access to your software or other copyrighted work, you may have a right to sue for relief under that Act.

Information contained in this publication regarding device applications and the like is provided only for your convenience and may be superseded by updates. It is your responsibility to ensure that your application meets with your specifications. MICROCHIP MAKES NO REPRESENTATIONS OR WARRANTIES OF ANY KIND WHETHER EXPRESS OR IMPLIED, WRITTEN OR ORAL, STATUTORY OR OTHERWISE, RELATED TO THE INFORMATION, INCLUDING BUT NOT LIMITED TO ITS CONDITION, QUALITY, PERFORMANCE, MERCHANTABILITY OR FITNESS FOR PURPOSE. Microchip disclaims all liability arising from this information and its use. Use of Microchip devices in life support and/or safety applications is entirely at the buyer's risk, and the buyer agrees to defend, indemnify and hold harmless Microchip from any and all damages, claims, suits, or expenses resulting from such use. No licenses are conveyed, implicitly or otherwise, under any Microchip intellectual property rights.

Trademarks

The Microchip name and logo, the Microchip logo, dsPIC, FlashFlex, KEELOQ, KEELOQ logo, MPLAB, PIC, PICmicro, PICSTART, PIC³² logo, rPIC, SST, SST Logo, SuperFlash and UNI/O are registered trademarks of Microchip Technology Incorporated in the U.S.A. and other countries.

FilterLab, Hampshire, HI-TECH C, Linear Active Thermistor, MTP, SEEVAL and The Embedded Control Solutions Company are registered trademarks of Microchip Technology Incorporated in the U.S.A.

Silicon Storage Technology is a registered trademark of Microchip Technology Inc. in other countries.

Analog-for-the-Digital Age, Application Maestro, BodyCom, chipKIT, chipKIT logo, CodeGuard, dsPICDEM, dsPICDEM.net, dsPICworks, dsSPEAK, ECAN, ECONOMONITOR, FanSense, HI-TIDE, In-Circuit Serial Programming, ICSP, Mindi, MiWi, MPASM, MPF, MPLAB Certified logo, MPLIB, MPLINK, mTouch, Omniclient Code Generation, PICC, PICC-18, PICDEM, PICDEM.net, PICkit, PICtail, REAL ICE, rFLAB, Select Mode, SQI, Serial Quad I/O, Total Endurance, TSHARC, UniWinDriver, WiperLock, ZENA and Z-Scale are trademarks of Microchip Technology Incorporated in the U.S.A. and other countries.

SQTP is a service mark of Microchip Technology Incorporated in the U.S.A.

GestIC and ULPP are registered trademarks of Microchip Technology Germany II GmbH & Co. KG, a subsidiary of Microchip Technology Inc., in other countries.

All other trademarks mentioned herein are property of their respective companies.

© 2013, Microchip Technology Incorporated, Printed in the U.S.A., All Rights Reserved.

 Printed on recycled paper.

ISBN: 9781620772270

QUALITY MANAGEMENT SYSTEM
CERTIFIED BY DNV
== ISO/TS 16949 ==

Microchip received ISO/TS-16949:2009 certification for its worldwide headquarters, design and wafer fabrication facilities in Chandler and Tempe, Arizona; Gresham, Oregon and design centers in California and India. The Company's quality system processes and procedures are for its PIC[®] MCUs and dsPIC[®] DSCs, KEELOQ[®] code hopping devices, Serial EEPROMs, microperipherals, nonvolatile memory and analog products. In addition, Microchip's quality system for the design and manufacture of development systems is ISO 9001:2000 certified.



MICROCHIP

Worldwide Sales and Service

AMERICAS

Corporate Office
2355 West Chandler Blvd.
Chandler, AZ 85224-6199
Tel: 480-792-7200
Fax: 480-792-7277
Technical Support:
<http://www.microchip.com/support>
Web Address:
www.microchip.com

Atlanta
Duluth, GA
Tel: 678-957-9614
Fax: 678-957-1455

Boston
Westborough, MA
Tel: 774-760-0087
Fax: 774-760-0088

Chicago
Itasca, IL
Tel: 630-285-0071
Fax: 630-285-0075

Cleveland
Independence, OH
Tel: 216-447-0464
Fax: 216-447-0643

Dallas
Addison, TX
Tel: 972-818-7423
Fax: 972-818-2924

Detroit
Farmington Hills, MI
Tel: 248-538-2250
Fax: 248-538-2260

Indianapolis
Noblesville, IN
Tel: 317-773-8323
Fax: 317-773-5453

Los Angeles
Mission Viejo, CA
Tel: 949-462-9523
Fax: 949-462-9608

Santa Clara
Santa Clara, CA
Tel: 408-961-6444
Fax: 408-961-6445

Toronto
Mississauga, Ontario,
Canada
Tel: 905-673-0699
Fax: 905-673-6509

ASIA/PACIFIC

Asia Pacific Office
Suites 3707-14, 37th Floor
Tower 6, The Gateway
Harbour City, Kowloon
Hong Kong
Tel: 852-2401-1200
Fax: 852-2401-3431

Australia - Sydney
Tel: 61-2-9868-6733
Fax: 61-2-9868-6755

China - Beijing
Tel: 86-10-8569-7000
Fax: 86-10-8528-2104

China - Chengdu
Tel: 86-28-8665-5511
Fax: 86-28-8665-7889

China - Chongqing
Tel: 86-23-8980-9588
Fax: 86-23-8980-9500

China - Hangzhou
Tel: 86-571-2819-3187
Fax: 86-571-2819-3189

China - Hong Kong SAR
Tel: 852-2943-5100
Fax: 852-2401-3431

China - Nanjing
Tel: 86-25-8473-2460
Fax: 86-25-8473-2470

China - Qingdao
Tel: 86-532-8502-7355
Fax: 86-532-8502-7205

China - Shanghai
Tel: 86-21-5407-5533
Fax: 86-21-5407-5066

China - Shenyang
Tel: 86-24-2334-2829
Fax: 86-24-2334-2393

China - Shenzhen
Tel: 86-755-8864-2200
Fax: 86-755-8203-1760

China - Wuhan
Tel: 86-27-5980-5300
Fax: 86-27-5980-5118

China - Xian
Tel: 86-29-8833-7252
Fax: 86-29-8833-7256

China - Xiamen
Tel: 86-592-2388138
Fax: 86-592-2388130

China - Zhuhai
Tel: 86-756-3210040
Fax: 86-756-3210049

ASIA/PACIFIC

India - Bangalore
Tel: 91-80-3090-4444
Fax: 91-80-3090-4123

India - New Delhi
Tel: 91-11-4160-8631
Fax: 91-11-4160-8632

India - Pune
Tel: 91-20-2566-1512
Fax: 91-20-2566-1513

Japan - Osaka
Tel: 81-6-6152-7160
Fax: 81-6-6152-9310

Japan - Tokyo
Tel: 81-3-6880-3770
Fax: 81-3-6880-3771

Korea - Daegu
Tel: 82-53-744-4301
Fax: 82-53-744-4302

Korea - Seoul
Tel: 82-2-554-7200
Fax: 82-2-558-5932 or
82-2-558-5934

Malaysia - Kuala Lumpur
Tel: 60-3-6201-9857
Fax: 60-3-6201-9859

Malaysia - Penang
Tel: 60-4-227-8870
Fax: 60-4-227-4068

Philippines - Manila
Tel: 63-2-634-9065
Fax: 63-2-634-9069

Singapore
Tel: 65-6334-8870
Fax: 65-6334-8850

Taiwan - Hsin Chu
Tel: 886-3-5778-366
Fax: 886-3-5770-955

Taiwan - Kaohsiung
Tel: 886-7-213-7828
Fax: 886-7-330-9305

Taiwan - Taipei
Tel: 886-2-2508-8600
Fax: 886-2-2508-0102

Thailand - Bangkok
Tel: 66-2-694-1351
Fax: 66-2-694-1350

EUROPE

Austria - Wels
Tel: 43-7242-2244-39
Fax: 43-7242-2244-393

Denmark - Copenhagen
Tel: 45-4450-2828
Fax: 45-4485-2829

France - Paris
Tel: 33-1-69-53-63-20
Fax: 33-1-69-30-90-79

Germany - Munich
Tel: 49-89-627-144-0
Fax: 49-89-627-144-44

Italy - Milan
Tel: 39-0331-742611
Fax: 39-0331-466781

Netherlands - Drunen
Tel: 31-416-690399
Fax: 31-416-690340

Spain - Madrid
Tel: 34-91-708-08-90
Fax: 34-91-708-08-91

UK - Wokingham
Tel: 44-118-921-5869
Fax: 44-118-921-5820

11/29/12



Компания «ЭлектроПласт» предлагает заключение долгосрочных отношений при поставках импортных электронных компонентов на взаимовыгодных условиях!

Наши преимущества:

- Оперативные поставки широкого спектра электронных компонентов отечественного и импортного производства напрямую от производителей и с крупнейших мировых складов;
- Поставка более 17-ти миллионов наименований электронных компонентов;
- Поставка сложных, дефицитных, либо снятых с производства позиций;
- Оперативные сроки поставки под заказ (от 5 рабочих дней);
- Экспресс доставка в любую точку России;
- Техническая поддержка проекта, помощь в подборе аналогов, поставка прототипов;
- Система менеджмента качества сертифицирована по Международному стандарту ISO 9001;
- Лицензия ФСБ на осуществление работ с использованием сведений, составляющих государственную тайну;
- Поставка специализированных компонентов (Xilinx, Altera, Analog Devices, Intersil, Interpoint, Microsemi, Aeroflex, Peregrine, Syfer, Eurofarad, Texas Instrument, Miteq, Cobham, E2V, MA-COM, Hittite, Mini-Circuits, General Dynamics и др.);

Помимо этого, одним из направлений компании «ЭлектроПласт» является направление «Источники питания». Мы предлагаем Вам помощь Конструкторского отдела:

- Подбор оптимального решения, техническое обоснование при выборе компонента;
- Подбор аналогов;
- Консультации по применению компонента;
- Поставка образцов и прототипов;
- Техническая поддержка проекта;
- Защита от снятия компонента с производства.



Как с нами связаться

Телефон: 8 (812) 309 58 32 (многоканальный)

Факс: 8 (812) 320-02-42

Электронная почта: org@eplast1.ru

Адрес: 198099, г. Санкт-Петербург, ул. Калинина, дом 2, корпус 4, литера А.