

REV	ECN NO	REVISIONS	DRN	CKD	APP	DATE
A		NEW RELEASE	KLJ			

PART NUMBER	LED COLOR	
	POS. 1	POS. 2
553-2210-100F	RED	BLANK
553-2211-100F	RED	RED
553-2212-100F	RED	GREEN
553-2213-100F	RED	YELLOW
553-2220-100F	GREEN	BLANK
553-2221-100F	GREEN	RED
553-2222-100F	GREEN	GREEN
553-2223-100F	GREEN	YELLOW
553-2231-100F	YELLOW	RED
553-2232-100F	YELLOW	GREEN
553-2233-100F	YELLOW	YELLOW
553-2299-100F	WHITE	WHITE

COLOR BIN LIMIT SPECIFICATIONS OF WHITE LED					
BIN	CHROMATICITY COORDINATES				
1	x	0.330	0.330	0.356	0.361
	y	0.360	0.318	0.351	0.385
2	x	0.287	0.296	0.330	0.330
	y	0.295	0.276	0.318	0.339
3	x	0.264	0.280	0.296	0.283
	y	0.267	0.248	0.276	0.305
4	x	0.283	0.287	0.330	0.330
	y	0.305	0.295	0.339	0.360

TOLERANCE FOR EACH COLOR BIN LIMIT IS ±0.01.

INTENSITY BIN LIMITS OF WHITE LED (mcd @ I _f =20mA)		
BIN	MIN	MAX
Q	1150	1500
R	1500	1900
S	1900	2500

TOLERANCE FOR EACH BIN LIMIT IS ±15%.

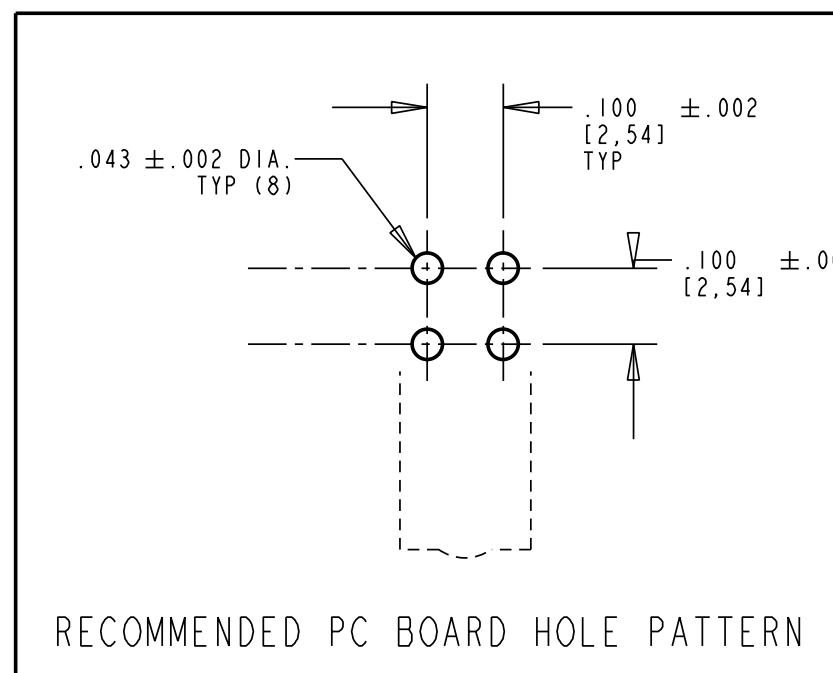
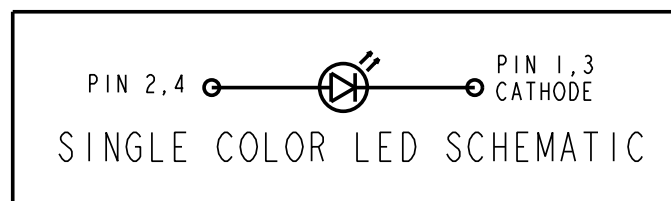
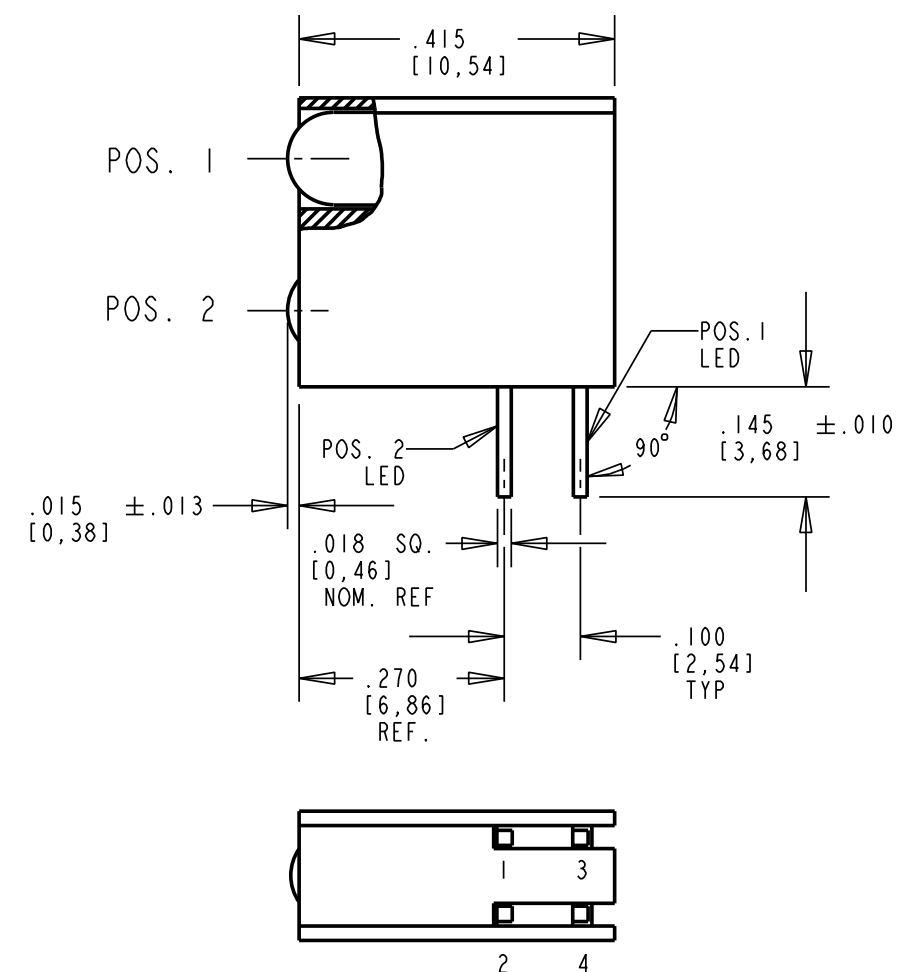
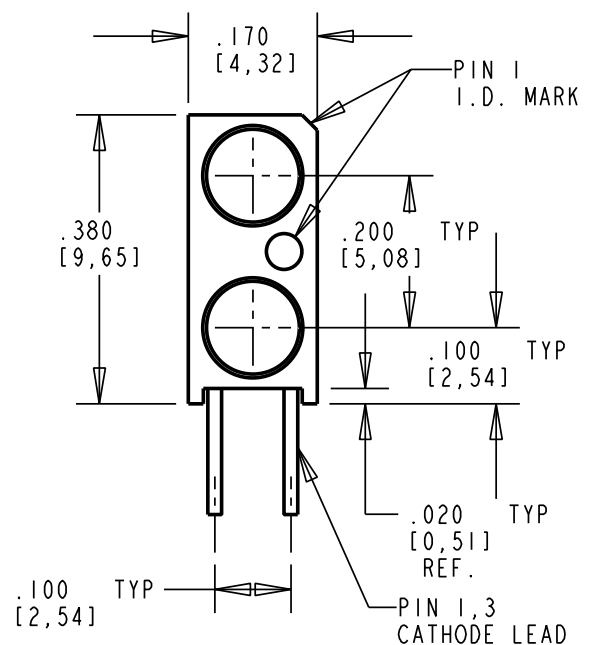

RoHS Compliant 553-22XX-100F

Part Numbers with the "F" suffix ending are RoHS Compliant. For example: 553-2222-100F. Packaging is marked with "RoHS Compliant" label or equivalent markings. Parts can be wave soldered, dip soldered or hand soldered using typical lead-free soldering process with max 260°C temp. for 5 sec.



OPERATING CHARACTERISTICS AT 25°C AMBIENT						
CHARACTERISTICS	COLOR	MIN	TYP	MAX	UNITS	TEST CONDITIONS
LUMINOUS INTENSITY	RED	8.7	29.0	—	mcd	I _f = 10 mA
	GREEN	32	50	—		
	YELLOW	10	—	50		I _f = 20 mA
	WHITE	950*	—	2900*		
FORWARD VOLTAGE	RED	—	2.0	2.8	V	I _f = 20 mA
	GREEN	—	2.1	2.8		
	YELLOW	—	2.1	2.8		
	WHITE	—	3.2	3.7		
REVERSE CURRENT	RED	—	—	100	μA	V _R = 5 V
	GREEN	—	—	100		
	YELLOW	—	—	100		
	WHITE	10	—	—		
PEAK WAVELENGTH	RED	—	635	—	nm	
	GREEN	—	565	—		
	YELLOW	—	585	—		
	WHITE	—	—	—		
VIEWING ANGLE	ALL	45		DEGREE		

ABSOLUTE MAXIMUM RATING AT 25°C AMBIENT			
POWER DISSIPATION	COLOR	VALUE	UNITS
	RED	100	mW
	GREEN	100	
	YELLOW	60	
WHITE	111		
DERATE LINEARLY FROM 50°C	COLOR	VALUE	UNITS
DERATE LINEARLY FROM 50°C	RED	0.4	mA/°C
DERATE LINEARLY FROM 50°C	GREEN	0.4	
DERATE LINEARLY FROM 50°C	YELLOW	0.25	
DERATE LINEARLY FROM 37°C	WHITE	0.42	
CONTINUOUS FORWARD CURRENT	COLOR	VALUE	UNITS
	RED	30	mA
	GREEN	30	
	YELLOW	20	
WHITE	30		
LEAD SOLDERING TEMPERATURE, 5 SEC., 1/16" FROM BODY	ALL	260	°C
OPERATING TEMPERATURE	COLOR	VALUE	UNITS
	RED	-55 TO +100	°C
	GREEN	-55 TO +100	
	YELLOW	-55 TO +100	
WHITE	-40 TO +85		
STORAGE TEMPERATURE	COLOR	VALUE	UNITS
	RED	-55 TO +100	°C
	GREEN	-55 TO +100	
	YELLOW	-55 TO +100	
WHITE	-40 TO +100		

- NOTES:
- LEADS TO FIT INTO HOLES SPACED AS PER HOLE PATTERN.
 - LEADS TO BE FREE OF DEFORMATION AFTER BENDING AND CUTTING.
 - LED LEAD DIMENSIONS SHOWN ARE MEASURED AT HOUSING EXIT.
 - PIN NUMBERS FOR REFERENCE ONLY, DESIGNATION NON-EXISTENT ON PARTS.
 - DIALIGHT PART NUMBERS: 553-22XX-100F
 - * THESE VALUES REFLECT A 15% TOLERANCE IN BINNING. WITHOUT THE 15% TOLERANCE, THE MINIMUM IS 1150mcd AND THE MAXIMUM IS 2500mcd.
 - THIS ASSEMBLY CONTAINS ELECTROSTATIC DISCHARGE SENSITIVE DEVICES (ESDS). MAINTAIN ALL PRECAUTIONARY MEASURES DURING ASSEMBLY, HANDLING AND STORAGE IN ACCORDANCE WITH IPC-A-610.

THIS DRAWING AND THE CONTENTS HEREIN ARE CONFIDENTIAL AND THE SOLE PROPERTY OF DIALIGHT. REPRODUCTION OF THIS DRAWING OR CONSTRUCTION OF ANY PARTS WITHIN THIS DRAWING ARE FORBIDDEN WITHOUT THE WRITTEN CONSENT OF DIALIGHT.		
SCALE: DRAWING SCALE ALL DIM'S IN: INCHES (MM)	DRAWING NUMBER C-17572	REV A
TOLERANCES: UNLESS OTHERWISE SPECIFIED	TITLE BI-LEVEL CBI ARRAY RoHS COMPLIANT	
FRACTIONS: ±1/64 DECIMALS (.XX): ±.01 DECIMALS (.XXX): ±.005 DECIMALS (.XXXX): ±.0005 ANGLES: ±1°	MATERIAL	
FINISH:	Dialight 1501 ROUTE 34 SOUTH FARMINGDALE, NJ 07727	
FSCM 83330	SHEET 1 OF 1 FAMILY TABLE:	



Компания «ЭлектроПласт» предлагает заключение долгосрочных отношений при поставках импортных электронных компонентов на взаимовыгодных условиях!

Наши преимущества:

- Оперативные поставки широкого спектра электронных компонентов отечественного и импортного производства напрямую от производителей и с крупнейших мировых складов;
- Поставка более 17-ти миллионов наименований электронных компонентов;
- Поставка сложных, дефицитных, либо снятых с производства позиций;
- Оперативные сроки поставки под заказ (от 5 рабочих дней);
- Экспресс доставка в любую точку России;
- Техническая поддержка проекта, помощь в подборе аналогов, поставка прототипов;
- Система менеджмента качества сертифицирована по Международному стандарту ISO 9001;
- Лицензия ФСБ на осуществление работ с использованием сведений, составляющих государственную тайну;
- Поставка специализированных компонентов (Xilinx, Altera, Analog Devices, Intersil, Interpoint, Microsemi, Aeroflex, Peregrine, Syfer, Eurofarad, Texas Instrument, Miteq, Cobham, E2V, MA-COM, Hittite, Mini-Circuits, General Dynamics и др.);

Помимо этого, одним из направлений компании «ЭлектроПласт» является направление «Источники питания». Мы предлагаем Вам помощь Конструкторского отдела:

- Подбор оптимального решения, техническое обоснование при выборе компонента;
- Подбор аналогов;
- Консультации по применению компонента;
- Поставка образцов и прототипов;
- Техническая поддержка проекта;
- Защита от снятия компонента с производства.



Как с нами связаться

Телефон: 8 (812) 309 58 32 (многоканальный)

Факс: 8 (812) 320-02-42

Электронная почта: org@eplast1.ru

Адрес: 198099, г. Санкт-Петербург, ул. Калинина, дом 2, корпус 4, литера А.