

Description

The 9DBU0531 is a member of IDT's 1.5V Ultra-Low-Power (ULP) PCIe family. The device has 5 output enables for clock management, and 3 selectable SMBus addresses.

Recommended Application

1.5V PCIe Gen1-2-3 Fanout Buffer (FOB)

Output Features

- 5 1–167MHz Low-Power (LP) HCSL DIF pairs

Key Specifications

- DIF *additive* cycle-to-cycle jitter < 5ps
- DIF output-to-output skew < 60ps
- DIF *additive* phase jitter is < 300fs rms for PCIe Gen3
- DIF *additive* phase jitter < 350fs rms for SGMII

Features/Benefits

- LP-HCSL outputs; save 10 resistors compared to standard HCSL outputs
- 35mW typical power consumption; eliminates thermal concerns
- Spread Spectrum (SS) compatible; allows SS for EMI reduction
- OE# pins for each output; support DIF power management
- HCSL-compatible differential input; can be driven by common clock sources
- Spread Spectrum tolerant; allows reduction of EMI
- SMBus-selectable features; optimize signal integrity to application
 - slew rate for each output
 - differential output amplitude
- Device contains default configuration; SMBus interface not required for device operation
- 3.3V tolerant SMBus interface works with legacy controllers
- 3 selectable SMBus addresses; multiple devices can easily share an SMBus segment
- 5 x 5 mm 32-VFQFPN; minimal board space

Block Diagram

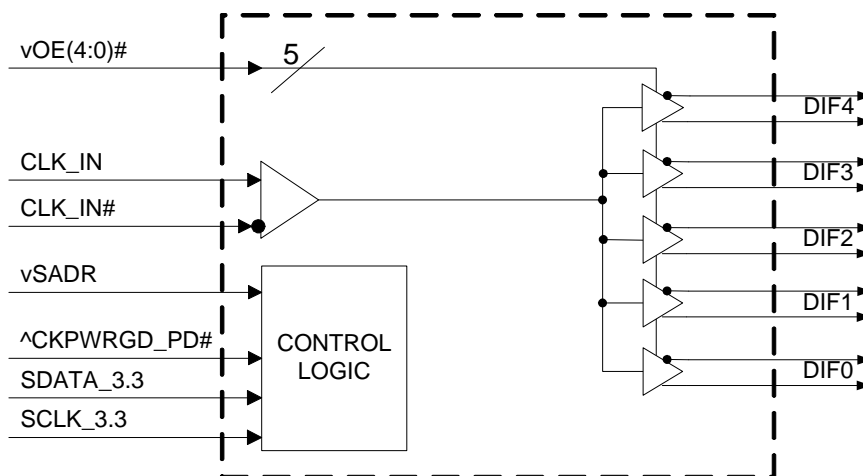

Pin Configuration

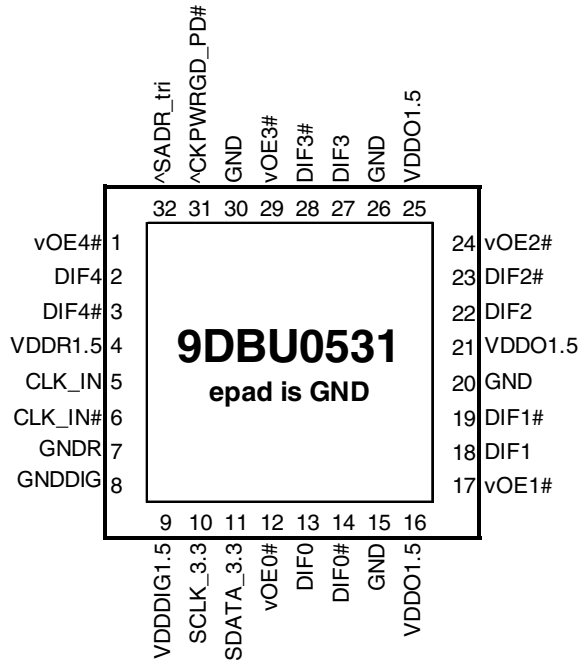

32-pin VFQFPN, 5x5 mm, 0.5mm pitch

- ^ prefix indicates internal 120KOhm pull up resistor
- ^v prefix indicates internal 120KOhm pull up AND pull down resistor (biased to VDD/2)
- v prefix indicates internal 120KOhm pull down resistor

SMBus Address Selection Table

	SADR	Address	+ Read/Write bit
State of SADR on first application of CKPWRGD_PD#	0	1101011	x
	M	1101100	x
	1	1101101	x

Power Management Table

CKPWRGD_PD#	CLK_IN	SMBus OEx bit	OEx# Pin	DIFx	
				True O/P	Comp. O/P
0	X	X	X	Low	Low
1	Running	0	X	Low	Low
1	Running	1	0	Running	Running
1	Running	1	1	Low	Low

Power Connections

Pin Number		Description
VDD	GND	
4	7	Input receiver analog
9	8	Digital power
16, 21, 25	15,20,26,30	DIF outputs

Note: EPAD on this device is not electrically connected to the die. It should be connected to ground for best thermal performance.

Pin Descriptions

Pin#	Pin Name	Type	Pin Description
1	vOE4#	IN	Active low input for enabling output 4. This pin has an internal 120kohm pull-down. 1 = disable outputs, 0 = enable outputs.
2	DIF4	OUT	Differential true clock output.
3	DIF4#	OUT	Differential complementary clock output.
4	VDDR1.5	PWR	1.5V power for differential input clock (receiver). This VDD should be treated as an Analog power rail and filtered appropriately.
5	CLK_IN	IN	True input for differential reference clock.
6	CLK_IN#	IN	Complementary input for differential reference clock.
7	GNDR	GND	Analog ground pin for the differential input (receiver)
8	GNDDIG	GND	Ground pin for digital circuitry.
9	VDDDIG1.5	PWR	1.5V digital power (dirty power)
10	SCLK_3.3	IN	Clock pin of SMBus circuitry, 3.3V tolerant.
11	SDATA_3.3	I/O	Data pin for SMBus circuitry, 3.3V tolerant.
12	vOE0#	IN	Active low input for enabling output 0. This pin has an internal 120kohm pull-down. 1 = disable outputs, 0 = enable outputs.
13	DIF0	OUT	Differential true clock output.
14	DIF0#	OUT	Differential complementary clock output.
15	GND	GND	Ground pin.
16	VDDO1.5	PWR	Power supply for outputs, nominally 1.5V.
17	vOE1#	IN	Active low input for enabling output 1. This pin has an internal 120kohm pull-down. 1 = disable outputs, 0 = enable outputs.
18	DIF1	OUT	Differential true clock output.
19	DIF1#	OUT	Differential complementary clock output.
20	GND	GND	Ground pin.
21	VDDO1.5	PWR	Power supply for outputs, nominally 1.5V.
22	DIF2	OUT	Differential true clock output.
23	DIF2#	OUT	Differential complementary clock output.
24	vOE2#	IN	Active low input for enabling output 2. This pin has an internal 120kohm pull-down. 1 = disable outputs, 0 = enable outputs.
25	VDDO1.5	PWR	Power supply for outputs, nominally 1.5V.
26	GND	GND	Ground pin.
27	DIF3	OUT	Differential true clock output.
28	DIF3#	OUT	Differential complementary clock output.
29	vOE3#	IN	Active low input for enabling output 3. This pin has an internal 120kohm pull-down. 1 = disable outputs, 0 = enable outputs.
30	GND	GND	Ground pin.
31	^CKPWRGD_PD#	IN	Input notifies device to sample latched inputs and start up on first high assertion. Low enters Power Down Mode, subsequent high assertions exit Power Down Mode. This pin has internal 120kohm pull-up resistor.
32	^SADR_tri	LATCHED IN	Tri-level latch to select SMBus Address. It has an internal 120kohm pull up resistor. See SMBus Address Selection Table.
33	EPAD	GND	Connect ePAD to ground.

Test Loads

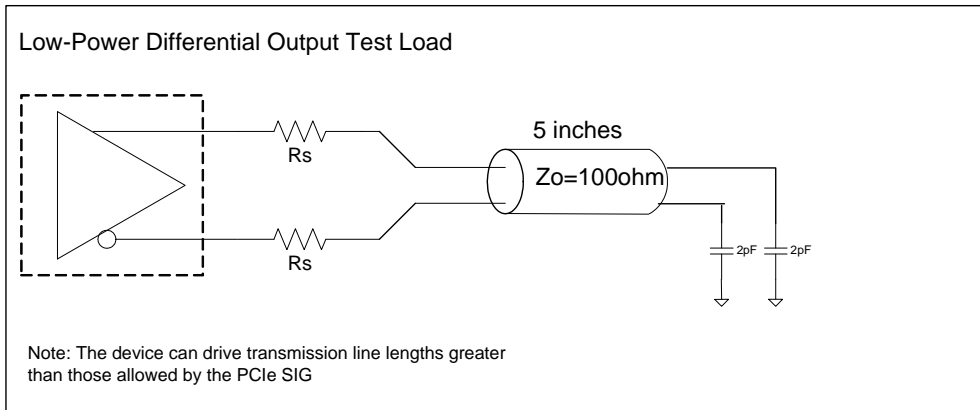

Alternate Differential Output Terminations

Rs	Zo	Units
33	100	Ohms
27	85	

Driving LVDS

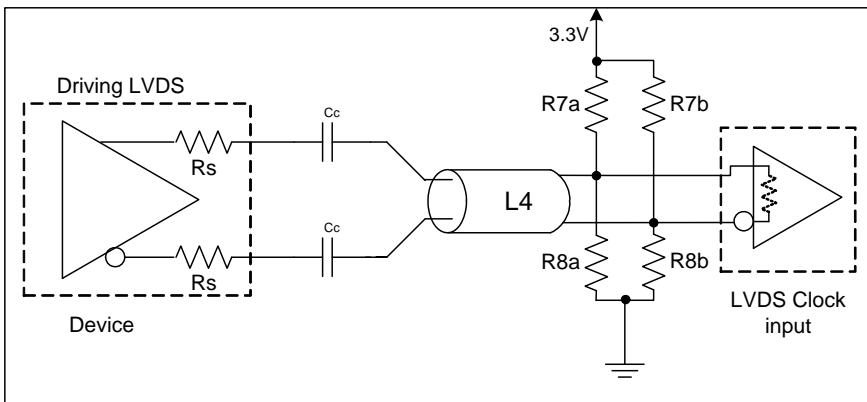

Driving LVDS Inputs

Component	Value	
	Receiver has termination	Receiver does not have termination
R7a, R7b	10K ohm	140 ohm
R8a, R8b	5.6K ohm	75 ohm
Cc	0.1µF	0.1µF
Vcm	1.2 volts	1.2 volts

Absolute Maximum Ratings

Stresses above the ratings listed below can cause permanent damage to the 9DBU0531. These ratings, which are standard values for IDT commercially rated parts, are stress ratings only. Functional operation of the device at these or any other conditions above those indicated in the operational sections of the specifications is not implied. Exposure to absolute maximum rating conditions for extended periods can affect product reliability. Electrical parameters are guaranteed only over the recommended operating temperature range.

PARAMETER	SYMBOL	CONDITIONS	MIN	TYP	MAX	UNITS	NOTES
Supply Voltage	VDDx	Applies to all VDD pins	-0.5		2	V	1,2
Input Voltage	V _{IN}		-0.5		V _{DD} +0.5	V	1,
Input High Voltage, SMBus	V _{IHSMB}	SMBus clock and data pins			3.3	V	1
Storage Temperature	T _s		-65		150	°C	1
Junction Temperature	T _j				125	°C	1
Input ESD Protection	ESD prot	Human Body Model	2000			V	1

¹ Guaranteed by design and characterization, not 100% tested in production.

² Operation under these conditions is neither implied nor guaranteed.

³ Not to exceed 2.0V.

Electrical Characteristics—Clock Input Parameters

T_A = T_{AMB}, Supply voltages per normal operation conditions; see Test Loads for loading conditions

PARAMETER	SYMBOL	CONDITIONS	MIN	TYP	MAX	UNITS	NOTES
Input Common Mode Voltage - DIF_IN	V _{COM}	Common mode input voltage	200		725	mV	1
Input Swing - DIF_IN	V _{SWING}	Differential value	300		1450	mV	1
Input Slew Rate - DIF_IN	dv/dt	Measured differentially	0.4		8	V/ns	1,2
Input Leakage Current	I _{IN}	V _{IN} = V _{DD} , V _{IN} = GND	-5		5	μA	
Input Duty Cycle	d _{tin}	Measurement from differential waveform	45	50	55	%	1
Input Jitter - Cycle to Cycle	J _{DIFIN}	Differential measurement	0		150	ps	1

¹ Guaranteed by design and characterization, not 100% tested in production.

² Slew rate measured through +/-75mV window centered around differential zero.

Electrical Characteristics–Input/Supply/Common Parameters–Normal Operating Conditions

TA = T_{AMB}; Supply voltages per normal operation conditions; see Test Loads for loading conditions

PARAMETER	SYMBOL	CONDITIONS	MIN	TYP	MAX	UNITS	NOTES
Supply Voltage	VDDx	Supply voltage for core and analog	1.425	1.5	1.575	V	
Ambient Operating Temperature	T _{AMB}	Commercial range	0	25	70	°C	1
		Industrial range	-40	25	85	°C	1
Input High Voltage	V _{IH}	Single-ended inputs, except SMBus	0.75 V _{DD}		V _{DD} + 0.3	V	
Input Mid Voltage	V _{IM}	Single-ended tri-level inputs ('_tri' suffix)	0.4 V _{DD}		0.6 V _{DD}	V	
Input Low Voltage	V _{IL}	Single-ended inputs, except SMBus	-0.3		0.25 V _{DD}	V	
Input Current	I _{IN}	Single-ended inputs, V _{IN} = GND, V _{IN} = VDD	-5		5	μA	
	I _{INP}	Single-ended inputs V _{IN} = 0 V; inputs with internal pull-up resistors V _{IN} = VDD; inputs with internal pull-down resistors	-200		200	μA	
Input Frequency	F _{in}		1		167	MHz	2
Pin Inductance	L _{pin}				7	nH	1
Capacitance	C _{IN}	Logic Inputs, except DIF_IN	1.5		5	pF	1
	C _{INDIF_IN}	DIF_IN differential clock inputs	1.5		2.7	pF	1,5
	C _{OUT}	Output pin capacitance			6	pF	1
Clk Stabilization	T _{STAB}	From V _{DD} power-up and after input clock stabilization or de-assertion of PD# to 1st clock			1	ms	1,2
Input SS Modulation Frequency PCIe	f _{MODINPCIe}	Allowable frequency for PCIe applications (Triangular modulation)	30		33	kHz	
Input SS Modulation Frequency non-PCIe	f _{MODIN}	Allowable frequency for non-PCIe applications (Triangular modulation)	0		66	kHz	
OE# Latency	t _{LATOE#}	DIF start after OE# assertion DIF stop after OE# deassertion	1		3	clocks	1,3
Tdrive_PD#	t _{DRVPD}	DIF output enable after PD# de-assertion			300	μs	1,3
Tfall	t _F	Fall time of single-ended control inputs			5	ns	2
Trise	t _R	Rise time of single-ended control inputs			5	ns	2
SMBus Input Low Voltage	V _{ILSMB}				0.6	V	
SMBus Input High Voltage	V _{IHSMB}	V _{DD} SMB = 3.3V, see note 4 for V _{DD} SMB < 3.3V	2.1		3.3	V	4
SMBus Output Low Voltage	V _{OLSMB}	at I _{PULLUP}			0.4	V	
SMBus Sink Current	I _{PULLUP}	at V _{OL}	4			mA	
Nominal Bus Voltage	V _{DD} SMB	Bus voltage	1.425		3.6	V	
SCLK/SDATA Rise Time	t _{RSMB}	(Max V _{IL} - 0.15V) to (Min V _{IH} + 0.15V)			1000	ns	1
SCLK/SDATA Fall Time	t _{FSMB}	(Min V _{IH} + 0.15V) to (Max V _{IL} - 0.15V)			300	ns	1
SMBus Operating Frequency	f _{MAXSMB}	Maximum SMBus operating frequency			400	kHz	6

¹ Guaranteed by design and characterization, not 100% tested in production.

² Control input must be monotonic from 20% to 80% of input swing.

³ Time from deassertion until outputs are > 200 mV.

⁴ For V_{DD}SMB < 3.3V, V_{IHSMB} > = 0.8xV_{DD}SMB.

⁵ DIF_IN input.

⁶ The differential input clock must be running for the SMBus to be active.

Electrical Characteristics–DIF Low-Power HCSL Outputs

TA = T_{AMB}; Supply voltages per normal operation conditions; see Test Loads for loading conditions

PARAMETER	SYMBOL	CONDITIONS	MIN	TYP	MAX	UNITS	NOTES
Slew Rate	dV/dt	Scope averaging on, fast setting	1.4	2.3	3.5	V/ns	1,2,3
	dV/dt	Scope averaging on, slow setting	0.9	1.5	2.5	V/ns	1,2,3
Slew Rate Matching	ΔdV/dt	Slew rate matching, scope averaging on		9.3	20	%	1,2,4
Voltage High	V _{HIGH}	Statistical measurement on single-ended signal using oscilloscope math function. (Scope averaging on)	630	750	850	mV	7
Voltage Low	V _{LOW}		-150	26	150		7
Max Voltage	V _{max}	Measurement on single ended signal using absolute value. (Scope averaging off)		763	1150	mV	7
Min Voltage	V _{min}		-300	22			7
Vswing	Vswing	Scope averaging off	300	1448		mV	1,2
Crossing Voltage (abs)	V _{cross_abs}	Scope averaging off	250	390	550	mV	1,5
Crossing Voltage (var)	Δ-V _{cross}	Scope averaging off		11	140	mV	1,6

¹Guaranteed by design and characterization, not 100% tested in production.

² Measured from differential waveform

³ Slew rate is measured through the Vswing voltage range centered around differential 0V. This results in a +/-150mV window around differential 0V.

⁴ Matching applies to rising edge rate for Clock and falling edge rate for Clock#. It is measured using a +/-75mV window centered on the average cross point where Clock rising meets Clock# falling. The median cross point is used to calculate the voltage thresholds the oscilloscope is to use for the edge rate calculations.

⁵ V_{cross} is defined as voltage where Clock = Clock# measured on a component test board and only applies to the differential rising edge (i.e. Clock rising and Clock# falling).

⁶ The total variation of all V_{cross} measurements in any particular system. Note that this is a subset of V_{cross_min/max} (V_{cross absolute}) allowed. The intent is to limit V_{cross} induced modulation by setting Δ-V_{cross} to be smaller than V_{cross absolute}.

⁷ At default SMBus settings.

Electrical Characteristics–Current Consumption

TA = T_{AMB}; Supply voltages per normal operation conditions; see Test Loads for loading conditions

PARAMETER	SYMBOL	CONDITIONS	MIN	TYP	MAX	UNITS	NOTES
Operating Supply Current	I _{DDR}	VDDR at 100MHz		1.84	3	mA	
	I _{DDDIG}	VDDIG, all outputs at 100MHz		0.09	0.5	mA	
	I _{DDAO}	VDDO1.5+VDDO, all outputs at 100MHz		21	25	mA	
Powerdown Current	I _{DDRPD}	VDDR, CKPWRGD_PD# = 0		0.001	0.3	mA	2
	I _{DDDIGPD}	VDDDIG, CKPWRGD_PD# = 0		0.1	0.2	mA	2
	I _{DDAOPD}	VDDO1.5+VDDO, CKPWRGD_PD# = 0		0.4	1	mA	2

¹ Guaranteed by design and characterization, not 100% tested in production.

² Input clock stopped.

Electrical Characteristics–Output Duty Cycle, Jitter, Skew and PLL Characteristics

TA = T_{AMB}: Supply voltages per normal operation conditions; see Test Loads for loading conditions

PARAMETER	SYMBOL	CONDITIONS	MIN	TYP	MAX	UNITS	NOTES
Duty Cycle Distortion	t _{DCD}	Measured differentially, at 100MHz	-1	-0.2	0.5	%	1,3
Skew, Input to Output	t _{pdBYP}	V _T = 50%	2400	2862	3700	ps	1
Skew, Output to Output	t _{sk3}	V _T = 50%		30	60	ps	1,4
Jitter, Cycle to Cycle	t _{jcy c-cyc}	Additive Jitter		0.1	5	ps	1,2

¹ Guaranteed by design and characterization, not 100% tested in production.

² Measured from differential waveform.

³ Duty cycle distortion is the difference in duty cycle between the output and the input clock.

⁴ All outputs at default slew rate.

Electrical Characteristics–Phase Jitter Parameters

TA = T_{AMB}: Supply voltages per normal operation conditions; see Test Loads for loading conditions

PARAMETER	SYMBOL	CONDITIONS	MIN	TYP	MAX	INDUSTRY LIMIT	UNITS	Notes
Additive Phase Jitter	t _{jphPCleG1}	PCIe Gen 1		0.1	5	N/A	ps (p-p)	1,2,3,5
	t _{jphPCleG2}	PCIe Gen 2 Lo Band 10kHz < f < 1.5MHz		0.1	0.4	N/A	ps (rms)	1,2,3,4,5
		PCIe Gen 2 High Band 1.5MHz < f < Nyquist (50MHz)		0.1	0.7	N/A	ps (rms)	1,2,3,4
	t _{jphPCleG3}	PCIe Gen 3 (2-4MHz or 2-5MHz, CDR = 10MHz)		0.1	0.3	N/A	ps (rms)	1,2,3,4
	t _{jphSGMIIM0}	125MHz, 1.5MHz to 10MHz, -20dB/decade rollover < 1.5MHz, -40db/decade rolloff > 10MHz		200	250	N/A	fs (rms)	1,6
t _{jphSGMIIM1}	125MHz, 12kHz to 20MHz, -20dB/decade rollover < 1.5MHz, -40db/decade rolloff > 10MHz		313	350	N/A	fs (rms)	1,6	

¹ Guaranteed by design and characterization, not 100% tested in production.

² See <http://www.pcisig.com> for complete specs.

³ Sample size of at least 100K cycles. This figure extrapolates to 108ps pk-pk @ 1M cycles for a BER of 1-12.

⁴ For RMS figures, additive jitter is calculated by solving the following equation: Additive jitter = SQRT[(total jitter)² - (input jitter)²].

⁵ Driven by 9FGV0831 or equivalent.

⁶ Rohde & Schwarz SMA100.

Additive Phase Jitter Plot: 125M (12kHz to 20MHz)

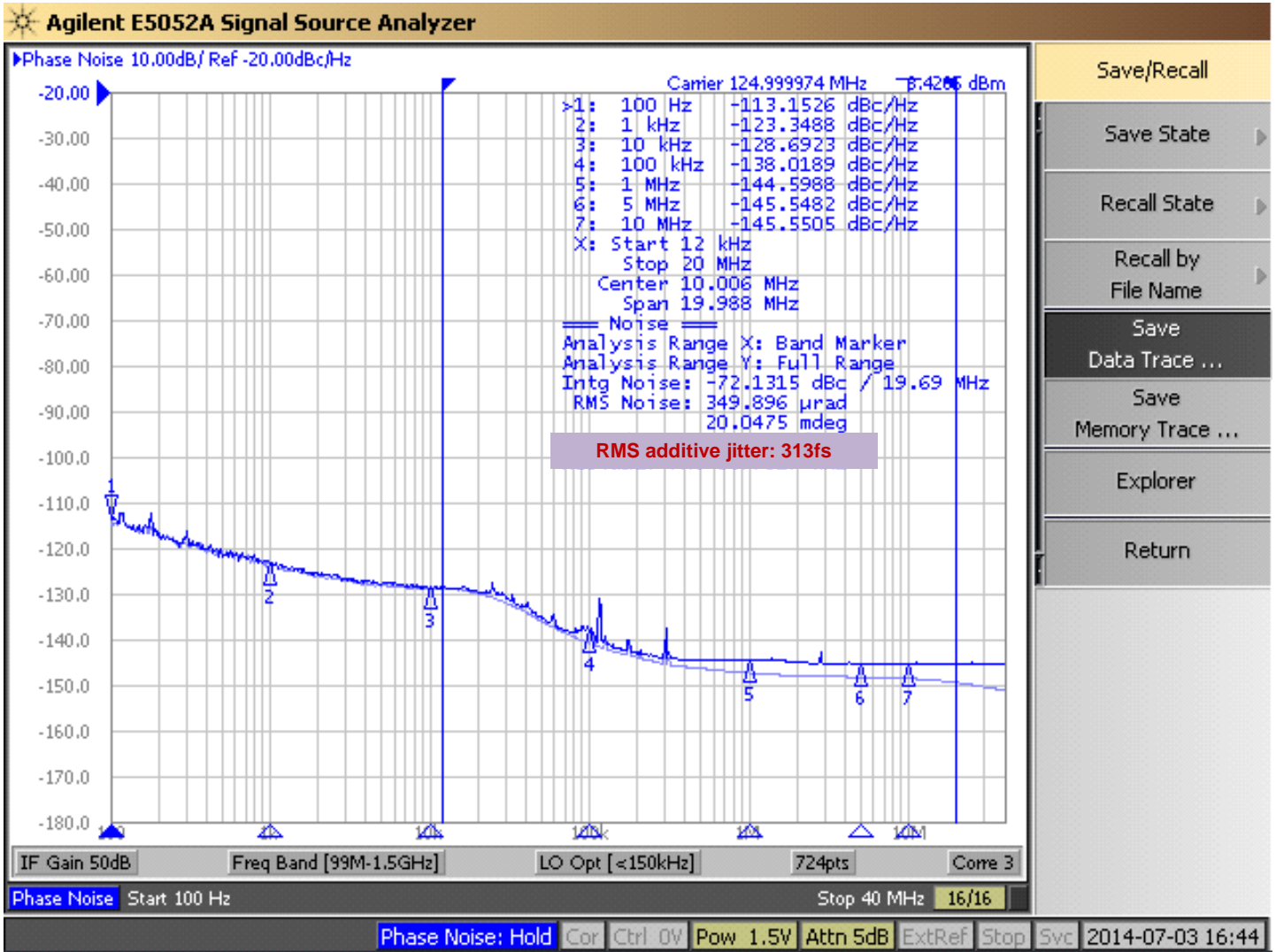

General SMBus Serial Interface Information

How to Write

- Controller (host) sends a start bit
- Controller (host) sends the write address
- IDT clock will **acknowledge**
- Controller (host) sends the beginning byte location = N
- IDT clock will **acknowledge**
- Controller (host) sends the byte count = X
- IDT clock will **acknowledge**
- Controller (host) starts sending Byte N through Byte N+X-1
- IDT clock will **acknowledge** each byte **one at a time**
- Controller (host) sends a stop bit

Index Block Write Operation			
Controller (Host)			IDT (Slave/Receiver)
T	starT bit		
Slave Address			
WR	WRite		
			ACK
Beginning Byte = N			
			ACK
Data Byte Count = X			
			ACK
Beginning Byte N		X Byte	
O			ACK
O			O
O			O
O			O
Byte N + X - 1			
			ACK
P	stoP bit		

Note: SMBus Address is Latched on SADR pin.

How to Read

- Controller (host) will send a start bit
- Controller (host) sends the write address
- IDT clock will **acknowledge**
- Controller (host) sends the beginning byte location = N
- IDT clock will **acknowledge**
- Controller (host) will send a separate start bit
- Controller (host) sends the read address
- IDT clock will **acknowledge**
- IDT clock will send the data byte count = X
- IDT clock sends Byte N+X-1
- IDT clock sends **Byte 0 through Byte X (if X_(H) was written to Byte 8)**
- Controller (host) will need to acknowledge each byte
- Controller (host) will send a not acknowledge bit
- Controller (host) will send a stop bit

Index Block Read Operation			
Controller (Host)			IDT (Slave/Receiver)
T	starT bit		
Slave Address			
WR	WRite		
			ACK
Beginning Byte = N			
			ACK
RT	Repeat starT		
Slave Address			
RD	ReaD		
			ACK
			Data Byte Count=X
ACK		X Byte	
ACK			Beginning Byte N
			O
			O
			O
			Byte N + X - 1
N	Not acknowledge		
P	stoP bit		

SMBus Table: Output Enable Register ¹

Byte 0	Name	Control Function	Type	0	1	Default
Bit 7	Reserved					1
Bit 6	DIF OE3	Output Enable	RW	Low/Low	Enabled	1
Bit 5	DIF OE2	Output Enable	RW	Low/Low	Enabled	1
Bit 4	Reserved					1
Bit 3	DIF OE1	Output Enable	RW	Low/Low	Enabled	1
Bit 2	Reserved					1
Bit 1	DIF OE0	Output Enable	RW	Low/Low	Enabled	1
Bit 0	Reserved					1

1. A low on these bits will override the OE# pin and force the differential output Low/Low

SMBus Table: PLL Operating Mode and Output Amplitude Control Register

Byte 1	Name	Control Function	Type	0	1	Default
Bit 7	Reserved					0
Bit 6	Reserved					1
Bit 5	DIF OE4	Output Enable	RW	Low/Low	Enabled	1
Bit 4	Reserved					0
Bit 3	Reserved					1
Bit 2	Reserved					1
Bit 1	AMPLITUDE 1	Controls Output Amplitude	RW	00 = 0.55V	01 = 0.65V	1
Bit 0	AMPLITUDE 0		RW	10 = 0.7V	11 = 0.8V	0

1. A low on the DIF OE bit will override the OE# pin and force the differential output Low/Low

SMBus Table: DIF Slew Rate Control Register

Byte 2	Name	Control Function	Type	0	1	Default
Bit 7	Reserved					1
Bit 6	SLEWRATESEL DIF3	Slew Rate Selection	RW	Slow Setting	Fast Setting	1
Bit 5	SLEWRATESEL DIF2	Slew Rate Selection	RW	Slow Setting	Fast Setting	1
Bit 4	Reserved					1
Bit 3	SLEWRATESEL DIF1	Slew Rate Selection	RW	Slow Setting	Fast Setting	1
Bit 2	Reserved					1
Bit 1	SLEWRATESEL DIF0	Slew Rate Selection	RW	Slow Setting	Fast Setting	1
Bit 0	Reserved					1

Note: See "DIF 0.7V Low-Power HCSL Outputs" table for slew rates.

SMBus Table: DIF Slew Rate Control Register

Byte 3	Name	Control Function	Type	0	1	Default
Bit 7	Reserved					1
Bit 6	Reserved					1
Bit 5	Reserved					0
Bit 4	Reserved					0
Bit 3	Reserved					0
Bit 2	Reserved					1
Bit 1	Reserved					1
Bit 0	SLEWRATESEL DIF4	Adjust Slew Rate of DIF4	RW	Slow Setting	Fast Setting	1

Note: See "DIF 0.7V Low-Power HCSL Outputs" table for slew rates.

Byte 4 is Reserved and reads back 'hFF'

SMBus Table: Revision and Vendor ID Register

Byte 5	Name	Control Function	Type	0	1	Default
Bit 7	RID3	Revision ID	R	A rev = 0000		0
Bit 6	RID2		R			0
Bit 5	RID1		R			0
Bit 4	RID0		R			0
Bit 3	VID3	VENDOR ID	R	0001 = IDT/ICS		0
Bit 2	VID2		R			0
Bit 1	VID1		R			0
Bit 0	VID0		R			1

SMBus Table: Device Type/Device ID

Byte 6	Name	Control Function	Type	0	1	Default
Bit 7	Device Type1	Device Type	R	00 = FGx, 01 = DBx, 10 = DMx, 11= DBx w/oPLL		1
Bit 6	Device Type0		R			1
Bit 5	Device ID5	Device ID	R	000101 binary or 05 hex		0
Bit 4	Device ID4		R			0
Bit 3	Device ID3		R			0
Bit 2	Device ID2		R			1
Bit 1	Device ID1		R			0
Bit 0	Device ID0		R			1

SMBus Table: Byte Count Register

Byte 7	Name	Control Function	Type	0	1	Default
Bit 7		Reserved				0
Bit 6		Reserved				0
Bit 5		Reserved				0
Bit 4	BC4	Byte Count Programming	RW	Writing to this register will configure how many bytes will be read back, default is = 8 bytes.		0
Bit 3	BC3		RW			1
Bit 2	BC2		RW			0
Bit 1	BC1		RW			0
Bit 0	BC0		RW			0

Marking Diagrams

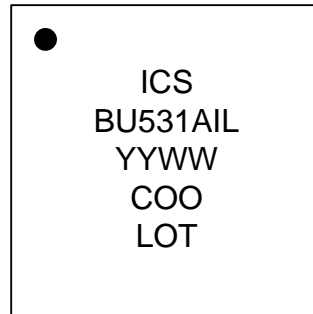
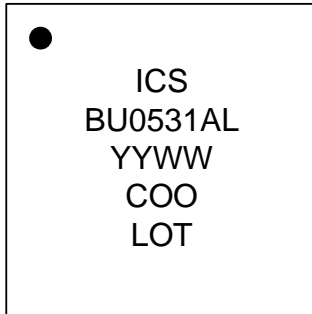

Notes:

1. "LOT" is the lot sequence number.
2. "COO" denotes country of origin.
3. YYWW is the last two digits of the year and week that the part was assembled.
4. Line 2: truncated part number
5. "L" denotes RoHS compliant package.
6. "I" denotes industrial temperature range device.

Thermal Characteristics

PARAMETER	SYMBOL	CONDITIONS	PKG	TYP VALUE	UNITS	NOTES
Thermal Resistance	θ_{JC}	Junction to Case	NLG32	42	°C/W	1
	θ_{Jb}	Junction to Base		2.4	°C/W	1
	θ_{JA0}	Junction to Air, still air		39	°C/W	1
	θ_{JA1}	Junction to Air, 1 m/s air flow		33	°C/W	1
	θ_{JA3}	Junction to Air, 3 m/s air flow		28	°C/W	1
	θ_{JA5}	Junction to Air, 5 m/s air flow		27	°C/W	1

¹ePad soldered to board

Package Outline and Dimensions (NLG32)

REVISIONS			
REV	DESCRIPTION	DATE	APPROVED
00	INITIAL RELEASE	11/23/15	J.H
01	MODIFY DIMENSION TABLE	11/30/15	J.H

TOLERANCES UNLESS SPECIFIED	
DECIMAL	±1°
XX.X	.1
XXX.X	.05
XXXX.X	.030

APPROVALS	
DRAWN	DATE
CHECKED	

TITLE	
NL/NLG 32 PACKAGE OUTLINE	
5.0 x 5.0 mm BODY, EPAD 3.10 mm SQ	
0.50 mm PITCH QFN.	

DRAWING No.	
C	PSC-4171-03

REV	
01	01

DO NOT SCALE DRAWING	
SHEET 1 OF 2	

NOTE :

- ALL DIMENSION ARE IN mm. ANGLES IN DEGREES.
- ALL DIMENSIONS ARE TO THE EXPOSED PAD AS WELL AS THE TERMINALS.
- WARPAGE SHALL NOT EXCEED 0.10 mm.

PIN #1 ID OPTION

Package Outline and Dimensions (NLG32), cont.

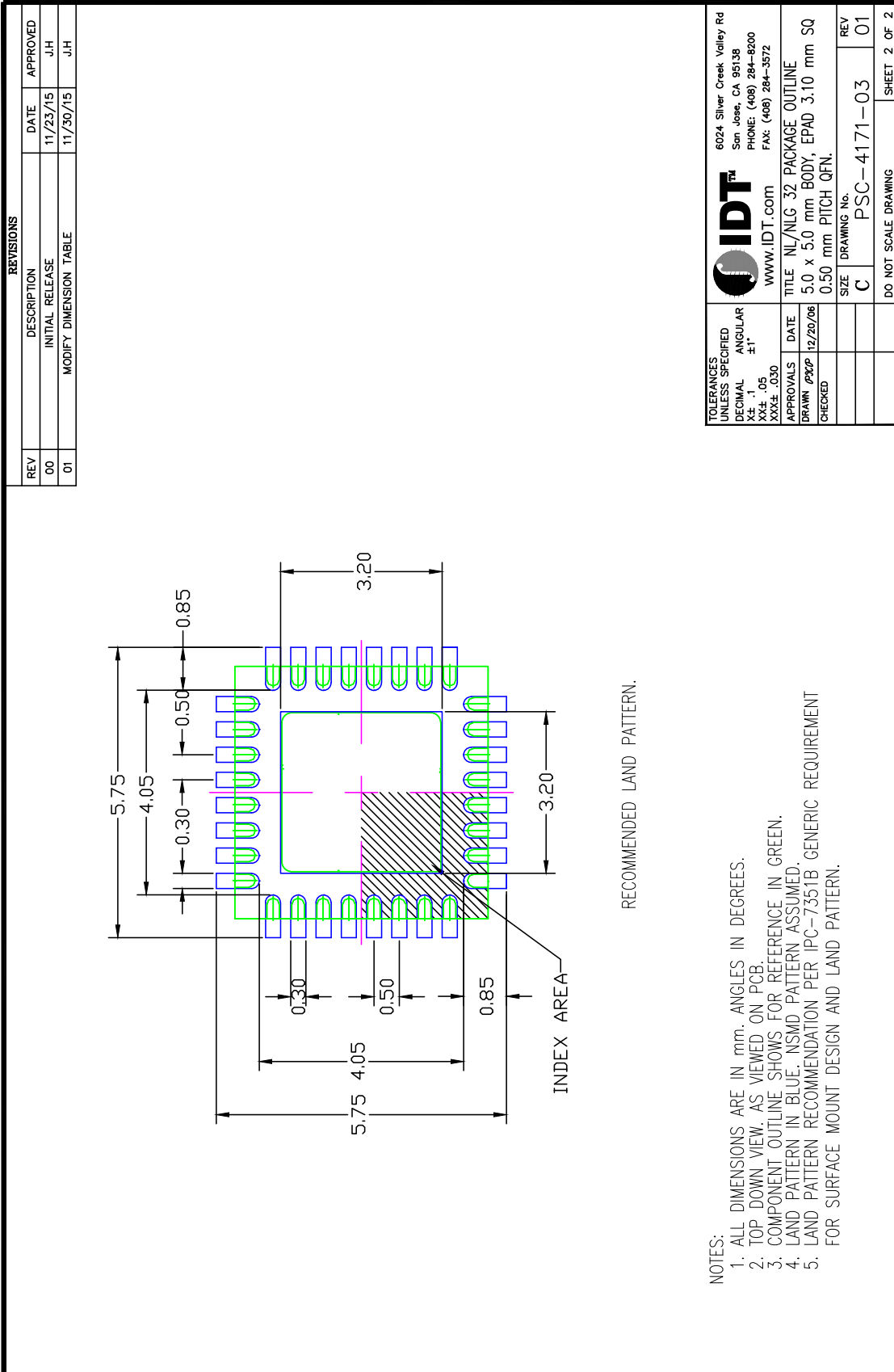

		6024 Silver Creek Valley Rd San Jose, CA 95138 PHONE: (408) 284-8200 FAX: (408) 284-3572 www.IDT.com	
TOLERANCES UNLESS SPECIFIED DECIMAL ±1 XX± .05 XXX± .030	APPROVALS DATE DRAWN ϕ XP 12/20/06 CHECKED	TITLE NL/NLG 32 PACKAGE OUTLINE 5.0 x 5.0 mm BODY, EPAD 3.10 mm SQ 0.50 mm PITCH QFN.	REV C PSC-4171-03 01 DO NOT SCALE DRAWING SHEET 2 OF 2

Ordering Information

Part / Order Number	Shipping Packaging	Package	Temperature
9DBU0531AKLF	Trays	32-pin VFQFPN	0 to +70° C
9DBU0531AKLFT	Tape and Reel	32-pin VFQFPN	0 to +70° C
9DBU0531AKILF	Trays	32-pin VFQFPN	-40 to +85° C
9DBU0531AKILFT	Tape and Reel	32-pin VFQFPN	-40 to +85° C

“LF” suffix to the part number are the Pb-Free configuration and are RoHS compliant.

“A” is the device revision designator (will not correlate with the datasheet revision).

Revision History

Rev.	Initiator	Issue Date	Description	Page #
A	RDW	7/15/2014	1. Final electrical table update, move to DS to release	Various
B	RDW	7/24/2014	1. Removed VDDIO reference in the Electrical Characteristics - Input/Supply/Common Parameters and Absolute Maximum Ratings tables. This power rail does not exist on this device. The pinout and the pin descriptions are correct.	6
C	RDW	9/19/2014	Updated SMBus Input High/Low parameters conditions, MAX values, and footnotes.	6
D	RDW	4/22/2014	1. Updated Key Specifications to be consistent across the family. 2. Updated pin out and pin descriptions to show ePad on package connected to ground. 3. Updated Clock Input Parameters table to be consistent with PCIe Vswing parameter. 4. Add note about epad to Power Connections table.	1-3,5
E	RDW	2/13/2017	1. Updated pins 21 and 20 from VDDA1.5/GNDA to VDDO1.5/GND to clearly indicate that this part has no PLL.	2, 3
F	RDW	3/9/2017	1. Removed "Bypass Mode" reference in "Output Duty Cycle..." and "Phase Jitter Parameters" tables; update note 3 under Output Duty Cycle table. 2. Corrected spelling errors/typos. 3. Change VDDA to VDDO1.5 in Current Consumption table. 4. Update Additive Phase Jitter conditions for PCIe Gen3.	7, 8



Corporate Headquarters
6024 Silver Creek Valley Road
San Jose, CA 95138 USA
www.idt.com

Sales
1-800-345-7015 or 408-284-8200
Fax: 408-284-2775
www.idt.com/go/sales

Tech Support
www.idt.com/go/support

DISCLAIMER Integrated Device Technology, Inc. (IDT) and its affiliated companies (herein referred to as "IDT") reserve the right to modify the products and/or specifications described herein at any time, without notice, at IDT's sole discretion. Performance specifications and operating parameters of the described products are determined in an independent state and are not guaranteed to perform the same way when installed in customer products. The information contained herein is provided without representation or warranty of any kind, whether express or implied, including, but not limited to, the suitability of IDT's products for any particular purpose, an implied warranty of merchantability, or non-infringement of the intellectual property rights of others. This document is presented only as a guide and does not convey any license under intellectual property rights of IDT or any third parties.

IDT's products are not intended for use in applications involving extreme environmental conditions or in life support systems or similar devices where the failure or malfunction of an IDT product can be reasonably expected to significantly affect the health or safety of users. Anyone using an IDT product in such a manner does so at their own risk, absent an express, written agreement by IDT.

Integrated Device Technology, IDT and the IDT logo are trademarks or registered trademarks of IDT and its subsidiaries in the United States and other countries. Other trademarks used herein are the property of IDT or their respective third party owners. For datasheet type definitions and a glossary of common terms, visit www.idt.com/go/glossary. Integrated Device Technology, Inc.. All rights reserved.



Компания «ЭлектроПласт» предлагает заключение долгосрочных отношений при поставках импортных электронных компонентов на взаимовыгодных условиях!

Наши преимущества:

- Оперативные поставки широкого спектра электронных компонентов отечественного и импортного производства напрямую от производителей и с крупнейших мировых складов;
- Поставка более 17-ти миллионов наименований электронных компонентов;
- Поставка сложных, дефицитных, либо снятых с производства позиций;
- Оперативные сроки поставки под заказ (от 5 рабочих дней);
- Экспресс доставка в любую точку России;
- Техническая поддержка проекта, помощь в подборе аналогов, поставка прототипов;
- Система менеджмента качества сертифицирована по Международному стандарту ISO 9001;
- Лицензия ФСБ на осуществление работ с использованием сведений, составляющих государственную тайну;
- Поставка специализированных компонентов (Xilinx, Altera, Analog Devices, Intersil, Interpoint, Microsemi, Aeroflex, Peregrine, Syfer, Eurofarad, Texas Instrument, Miteq, Cobham, E2V, MA-COM, Hittite, Mini-Circuits, General Dynamics и др.);

Помимо этого, одним из направлений компании «ЭлектроПласт» является направление «Источники питания». Мы предлагаем Вам помощь Конструкторского отдела:

- Подбор оптимального решения, техническое обоснование при выборе компонента;
- Подбор аналогов;
- Консультации по применению компонента;
- Поставка образцов и прототипов;
- Техническая поддержка проекта;
- Защита от снятия компонента с производства.



Как с нами связаться

Телефон: 8 (812) 309 58 32 (многоканальный)

Факс: 8 (812) 320-02-42

Электронная почта: org@eplast1.ru

Адрес: 198099, г. Санкт-Петербург, ул. Калинина, дом 2, корпус 4, литера А.