

## FEATURES

- Provides crosspoint switching between any input pair to any output pair
- Ultra-low jitter design:
  - $67\text{fs}_{\text{RMS}}$  phase jitter (typ)
- Guaranteed AC performance over temperature and voltage:
  - DC to >5Gbps throughput
  - <350ps propagation delay
  - <60ps  $t_r/t_f$  times
  - <25ps skew (output-to-output)
- Unique, patent-pending, channel-to-channel isolation design provides superior crosstalk performance
- Unique, patent-pending, 50Ω input termination extended CMVR, and VT pin accepts DC- and AC-coupled differential inputs
- 400mV CML output swing
- 50Ω source terminated outputs minimize round-trip reflections
- Power supply 2.5V ±5% or 3.3V ±10%
- -40°C to +85°C temperature range
- Available in 44-pin (7mm × 7mm) QFN package
- Pb-Free green package



Precision Edge®

## DESCRIPTION

The SY58040U is a low jitter, low skew, high-speed 4×4 crosspoint switch optimized for precision telecom and enterprise server/storage distribution applications. The SY58040U distributes clock frequencies from DC to 4GHz, and data rates to 5Gbps guaranteed over temperature and voltage.

The SY58040U differential input includes Micrel's unique, 3-pin input termination architecture that directly interfaces to any differential signal (AC- or DC-coupled) as small as 100mV (200mV<sub>pp</sub>) without any level shifting or termination resistor networks in the signal path. The outputs are 50Ω source-terminated CML with extremely fast rise/fall times guaranteed to be less than 60ps.

The SY58040U features a patent-pending isolation design that significantly improves on channel-to-channel crosstalk performance.

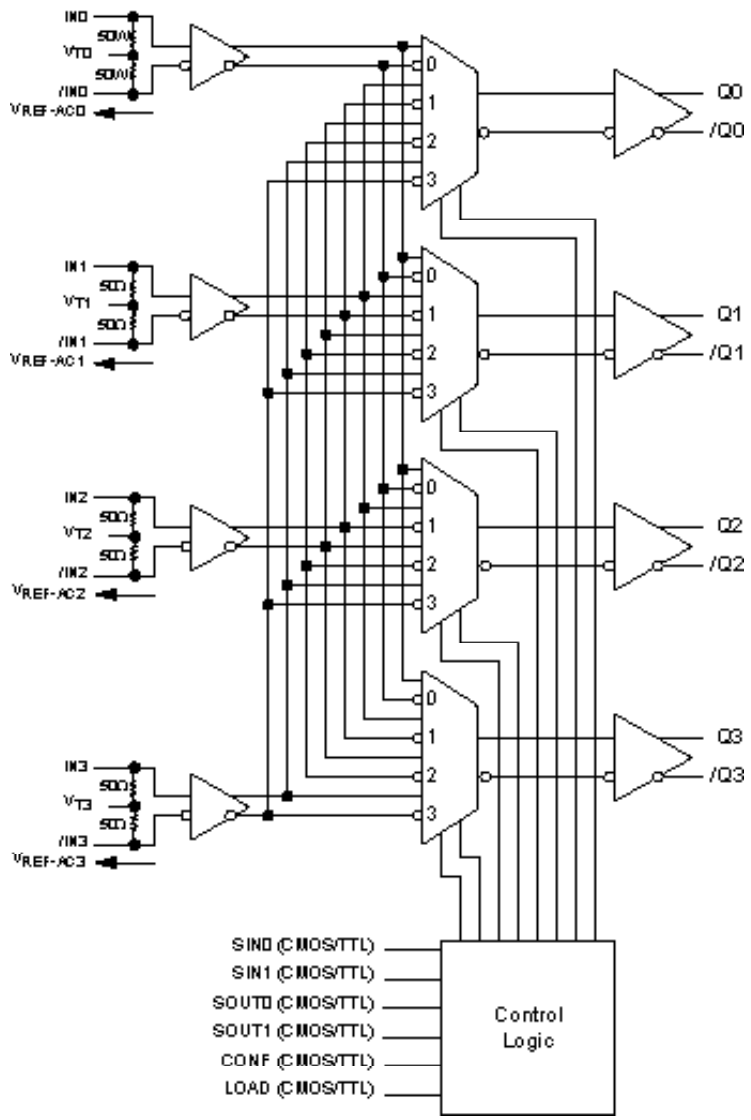
The SY58040U operates from a 2.5V ±5% or 3.3V ±10% supply and is guaranteed over the full industrial temperature range of -40°C to +85°C. The SY58040U is part of Micrel's high-speed, Precision Edge® product line.

Datasheets and support documentation can be found on Micrel's web site at: [www.micrel.com](http://www.micrel.com).

## APPLICATIONS

- Data communication systems
- All SONET/SDH data/clock applications
- All Fibre Channel applications
- All Gigabit Ethernet applications

**FUNCTIONAL BLOCK DIAGRAM**



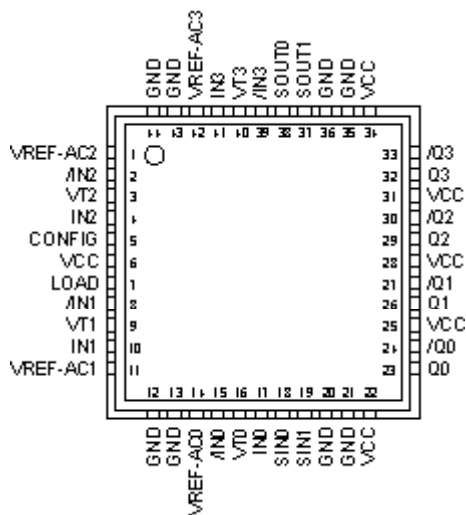
**TRUTH TABLES**

SIN1	SIN0	INPUT
0	0	IN0
0	1	IN1
1	0	IN2
1	1	IN3

SOUT1	SOUT0	OUTPUT
0	0	Q0
0	1	Q1
1	0	Q2
1	1	Q3

**PACKAGE/ORDERING INFORMATION**

**Ordering Information<sup>(1)</sup>**



**44-Pin QFN (QFN-44)**

Part Number	Package Type	Operating Range	Package Marking
SY58040UMY <sup>(3)</sup>	QFN-44 Pb-Free	Industrial	SY58040U Pb-Free bar-line indicator
SY58040UMYTR <sup>(2, 3)</sup>	QFN-44 Pb-Free	Industrial	SY58040U Pb-Free bar-line indicator

**Notes:**

1. Contact factory for die availability. Dice are guaranteed at T<sub>A</sub> = 25°C, DC electricals only.
2. Tape and Reel.
3. Pb-Free package recommended for new designs.

**PIN DESCRIPTION**

Pin Number	Pin Name	Pin Function
17, 15, 10, 8, 4, 2, 41, 39	IN0, /IN0 IN1, /IN1 IN2, /IN2 IN3, /IN3	Differential Inputs: These input pairs are the differential signal inputs to the device. Inputs accept AC or DC-coupled signals as small as 100mV. Each pin of a pair internally terminates to a VT pin through 50Ω. Note that these inputs will default to an indeterminate state if left open. Please refer to the “Input Interface Applications” section for more details.
16, 9, 3, 40	VT0, VT1 VT2, VT3	Input Termination Center-Tap: Each side of the differential input pair terminates to a VT pin. The VT pins provide a center-tap to a termination network for maximum interface flexibility. See “Input Interface Applications” section for more details.
14, 11, 1, 42	VRef_AC0 VRef_AC1 VRef_AC2 VRef_AC3	Reference Voltage: This output biases to V <sub>CC</sub> -1.2V. It is used when AC coupling the inputs. Connect VRef-AC output pin to the VT input pin. Bypass each VRef-AC pin with a 0.01μF low ESR capacitor to V <sub>CC</sub> . See “Input Interface Applications” section for more details.
18 19	SIN0 SIN1	These single-ended TTL/CMOS-compatible inputs address the data inputs. Note that these inputs are internally connected to a 25kΩ pull-up resistor and will default to a logic HIGH state if left open.
38 37	SOUT0 SOUT1	These single-ended TTL/CMOS-compatible inputs address the data outputs. Note that these inputs are internally connected to a 25kΩ pullup resistor and will default to a logic HIGH state if left open.
5 7	CONF, LOAD	These single-ended TTL/CMOS compatible inputs control the transfer of the addresses to the internal multiplexers. See “Address Tables” and “Timing Diagram” sections for more details. Note that these inputs are internally connected to a 25kΩ pull-up resistor and will default to a logic HIGH state if left open.  <i>Configuration Sequence</i>  1. Load: Loads configuration into buffer, while Configuration Buffer holds existing switch configuration. 2. Configuration: Loads new configuration into the Configuration Buffer and updates switch configuration.  <i>Buffer Mode</i>  The SY58040U defaults to buffer mode (IN-to-Q) if the load and configuration control signals are floating.
23, 24, 26, 27, 29, 30 32, 33	Q0, /Q0, Q1, /Q1, Q2, /Q2, Q3, /Q3,	Differential Outputs: These CML output pairs are the outputs of the device. Please refer to the truth table below for details. Unused output pairs may be left open. Each output is designed to drive 400mV into 100Ω across the pair, or 50Ω to V <sub>CC</sub> .
6, 22, 25, 28, 31, 34	VCC	Positive power supply. Bypass with 0.1μF//0.01μF low ESR capacitors and place as close to each V <sub>CC</sub> pin.
12, 13, 20, 21, 35, 36, 43, 44	GND, Exposed pad	Ground. GND and EPad must both be connected to most negative potential of chip ground.

### Absolute Maximum Ratings<sup>(1)</sup>

Power Supply Voltage ( $V_{CC}$ ) ..... -0.5V to +4.0V  
 Input Voltage ( $V_{IN}$ ) ..... -0.5V to  $V_{CC}$   
 CML Output Voltage ( $V_{OUT}$ ) .....  $V_{CC}$  -0.5V to  $V_{CC}$  +5.0V  
 Termination Current<sup>(3)</sup>  
     Source or sink current on VT pin .....  $\pm 100$ mA  
 Input Current<sup>(3)</sup>  
     Source or sink current on IN, /IN .....  $\pm 50$ mA  
 $V_{REF-AC}$  Current<sup>(3)</sup>  
     Source or sink current on IN, /IN .....  $\pm 2$ mA  
 Lead Temperature (soldering, 20 sec.) ..... 260°C  
 Storage Temperature Range ( $T_S$ ) ..... -65°C to +150°C

### Operating Ratings<sup>(2)</sup>

Power Supply Voltage ( $V_{CC}$ ) ..... +2.375V to +3.60V  
 Ambient Temperature Range ( $T_A$ ) ..... -40°C to +85°C  
 Package Thermal Resistance<sup>(4)</sup>  
     QFN ( $\theta_{JA}$ )  
         Still-Air ..... 23°C/W  
     QFN ( $\psi_{JB}$ )  
         Junction-to-board ..... 12°C/W

## DC ELECTRICAL CHARACTERISTICS<sup>(5)</sup>

$T_A = -40^\circ\text{C}$  to  $+85^\circ\text{C}$ , unless otherwise stated.

Symbol	Parameter	Condition	Min	Typ	Max	Units
$V_{CC}$	Power Supply Voltage	$V_{CC} = 2.5\text{V}$ .	2.375	2.5	2.625	V
		$V_{CC} = 3.3\text{V}$ .	3.0	3.3	3.6	V
$I_{CC}$	Power Supply Current	No load, max. $V_{CC}$ . Includes current from internal 50Ω pull-up on each output.		225	300	mA
$R_{IN}$	Input Resistance (IN-to- $V_T$ , /IN-to- $V_T$ )		45	50	55	Ω
$R_{DIFF\_IN}$	Differential Input Resistance (IN-to-/IN)		90	100	110	Ω
$V_{IH}$	Input HIGH Voltage (IN-to-/IN)	<b>Note 6</b>	$V_{CC}-1.6$		$V_{CC}$	V
$V_{IL}$	Input LOW Voltage (IN-to-/IN)		0		$V_{IH}-0.1$	V
$V_{IN}$	Input Voltage Swing (IN-to-/IN)	See Figure 1a.	0.1		1.7	V
$V_{DIFF\_IN}$	Differential Input Voltage Swing $ I_N - /I_N $	See Figure 1b.	0.2			V
$V_{T\_IN}$	IN to $V_T$ (IN-to-/IN)				1.28	V
$V_{REF-AC}$	Output Reference Voltage		$V_{CC}-1.3$	$V_{CC}-1.2$	$V_{CC}-1.1$	V

**Notes:**

1. Permanent device damage may occur if ratings in the "Absolute Maximum Ratings" section are exceeded. This is a stress rating only and functional operation is not implied for conditions other than those detailed in the operational sections of this data sheet. Exposure to absolute maximum ratings conditions for extended periods may affect device reliability.
2. The data sheet limits are not guaranteed if the device is operated beyond the operating ratings.
3. Due to the limited drive capability, use for input of the same package only.
4. Package thermal resistance assumes exposed pad is soldered (or equivalent) to the device's most negative potential on the PCB.  $\theta_{JA}$  uses 4-layer in still-air number, unless otherwise stated.
5. The circuit is designed to meet the DC specifications shown in the above table after thermal equilibrium has been established.
6.  $V_{IH}$  (min) not lower than 1.2V.

**CML OUTPUT DC ELECTRICAL CHARACTERISTICS<sup>(7)</sup>**

$V_{CC} = 2.5V \pm 5\%$  or  $3.3V \pm 10\%$ ;  $T_A = -40^\circ C$  to  $+85^\circ C$ ;  $R_L = 100\Omega$  across each output pair, unless otherwise stated.

Symbol	Parameter	Condition	Min	Typ	Max	Units
$V_{OH}$	Output HIGH Voltage Q, /Q		$V_{CC}-0.040$	$V_{CC}-0.010$	$V_{CC}$	V
$V_{OUT}$	Output Differential Swing Q, /Q	See Figure 1a.	325	400		mV
$V_{DIFF\_OUT}$	Differential Output Voltage Swing Q, /Q	See Figure 1b.	650	800		mV
$R_{OUT}$	Output Source Impedance		45	50	55	$\Omega$

**LVTTL/CMOS DC ELECTRICAL CHARACTERISTICS<sup>(7)</sup>**

$V_{CC} = 2.5V \pm 5\%$  or  $3.3V \pm 10\%$ ;  $T_A = -40^\circ C$  to  $+85^\circ C$ , unless otherwise stated.

Symbol	Parameter	Condition	Min	Typ	Max	Units
$V_{IH}$	Input HIGH Voltage		2.0		$V_{CC}$	V
$V_{IL}$	Input LOW Voltage				0.8	V
$I_{IH}$	Input HIGH Current		-125		30	$\mu A$
$I_{IL}$	Input LOW Current	$V_{IL} = 0V$ .	-300			$\mu A$

**Note:**

7. The circuit is designed to meet the DC specifications shown in the above table after thermal equilibrium has been established.

**AC ELECTRICAL CHARACTERISTICS<sup>(8)</sup>**

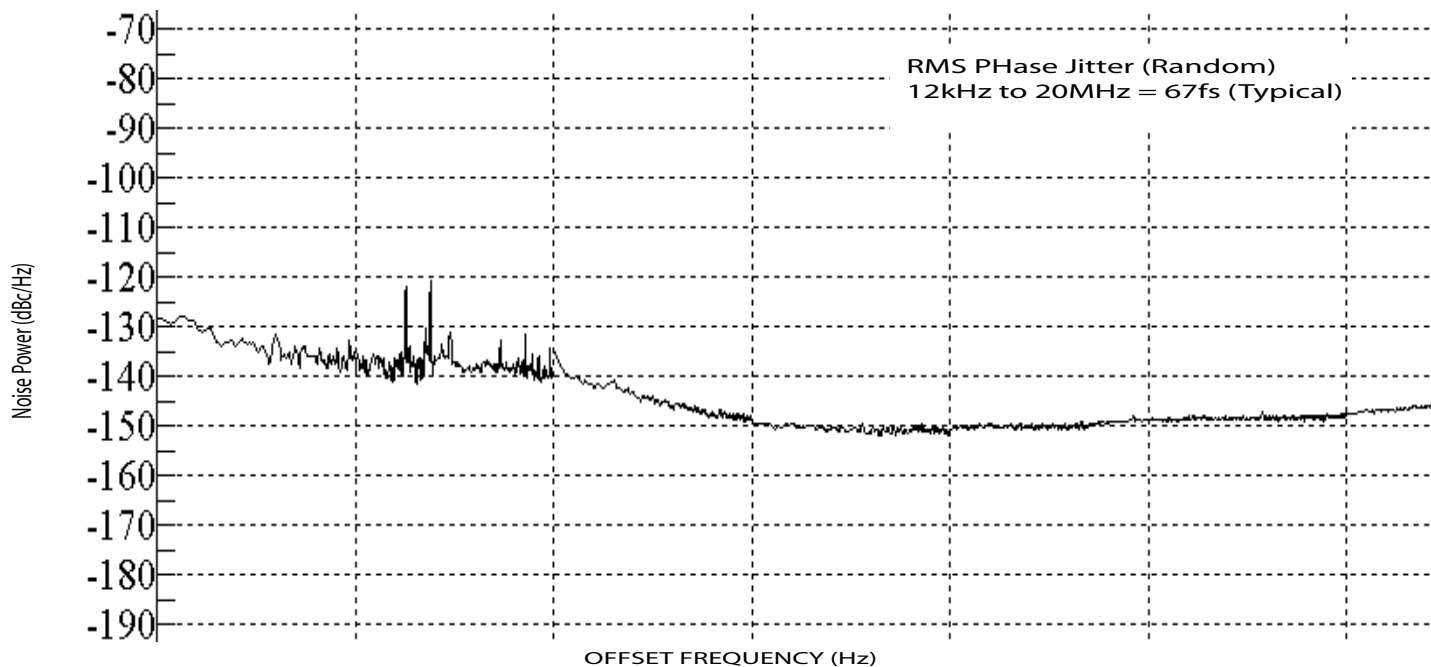
$V_{CC} = 2.5V \pm 5\%$  or  $3.3V \pm 10\%$ ;  $T_A = -40^{\circ}C$  to  $+85^{\circ}C$ ,  $R_L = 100\Omega$  across each output pair, unless otherwise stated.

Symbol	Parameter	Condition	Min	Typ	Max	Units
$f_{MAX}$	Maximum Operating Frequency	NRZ data	5			Gbps
		$V_{OUT} \geq 200mV$ Clock		3		GHz
$t_{pd}$	Differential Propagation Delay	IN-to-Q	150	225	350	ps
		CONFIG-to-Q			500	ps
$t_{pw}$	Pulse Width of LOAD/CONFIG signal		1500			ps
$\Delta t_{pd}$ Tempco	Differential Propagation Delay Temperature Coefficient			225		fs/ $^{\circ}C$
$t_S$	Set-Up Time	SIN-to-LOAD	800			ps
		SOUT-to-LOAD	800			ps
		LOAD-to-CONFIG	800			ps
		CONFIG-to-LOAD	950			ps
$t_H$	Hold Time	LOAD-to-SIN, LOAD-to-SOUT	800			ps
$t_{SKEW}$	Output-to-Output Skew Part-to-Part Skew	<b>Note 9</b>			25	ps
		<b>Note 10</b>			150	ps
$t_{JITTER}$	RMS Phase Jitter	Output = 622MHz; Integraion Range: 12kHz - 20MHz		67		fs <sub>RMS</sub>
$t_r, t_f$	Output Rise/Fall Time	At full output swing, 20% to 80%.	20	40	60	ps

**Notes:**

- 8. High-frequency AC-parameters are guaranteed by design and characterization.
- 9. Output-to-output skew is measured between two different outputs under identical input transitions.
- 10. Part-to-part skew is defined for two parts with identical power supply voltages at the same temperature and with no skew of the edges at the respective inputs

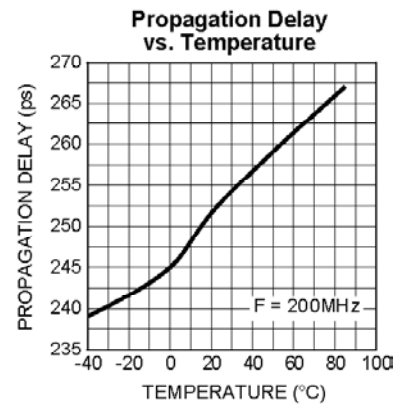
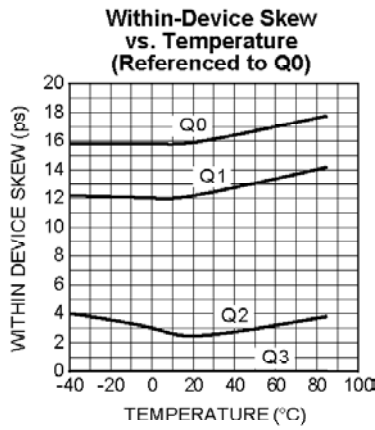
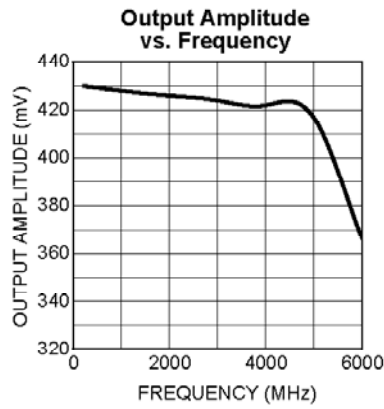
**PHASE NOISE**



Phase Noise Plot: 622MHz @ 3.3V

**TYPICAL OPERATING CHARACTERISTICS**

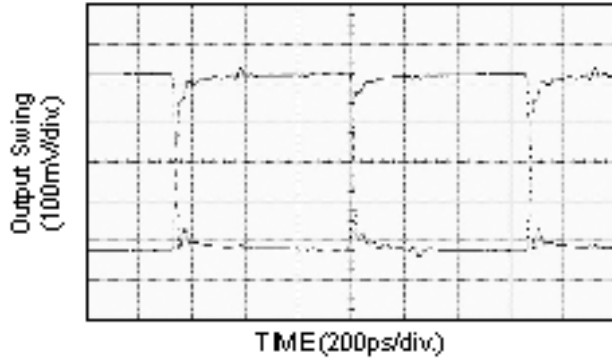
$V_{CC} = 3.3V$ ,  $GND = 0$ ,  $V_{IN} = 100mV$ ,  $T_A = 25^\circ C$ , unless otherwise stated.



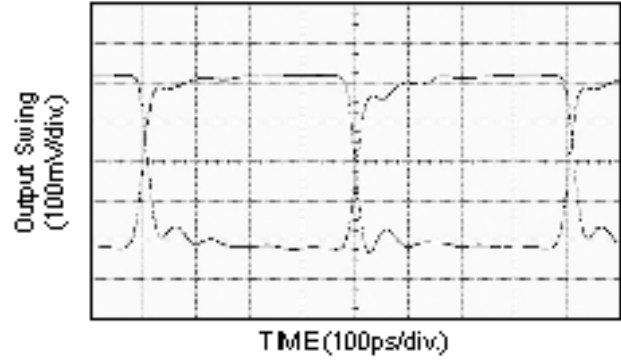
# FUNCTIONAL CHARACTERISTICS

$V_{CC} = 3.3V$ ,  $GND = 0$ ,  $V_{IN} = 100mV$ ,  $T_A = 25^\circ C$ , unless otherwise stated.

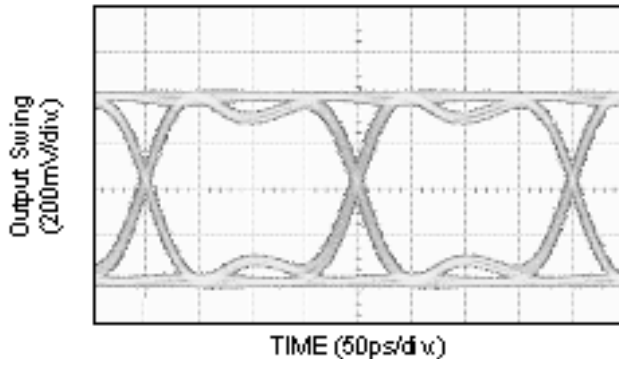
200M Hz Output



622M Hz Output



5Gbps Output (Q - /Q)





**SINGLE-ENDED AND DIFFERENTIAL SWINGS**

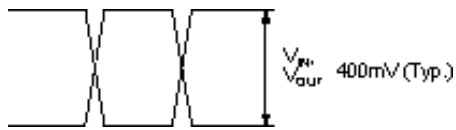


Figure 1a. Single-Ended Voltage Swing

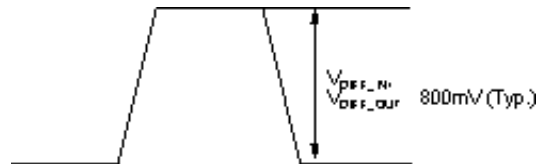
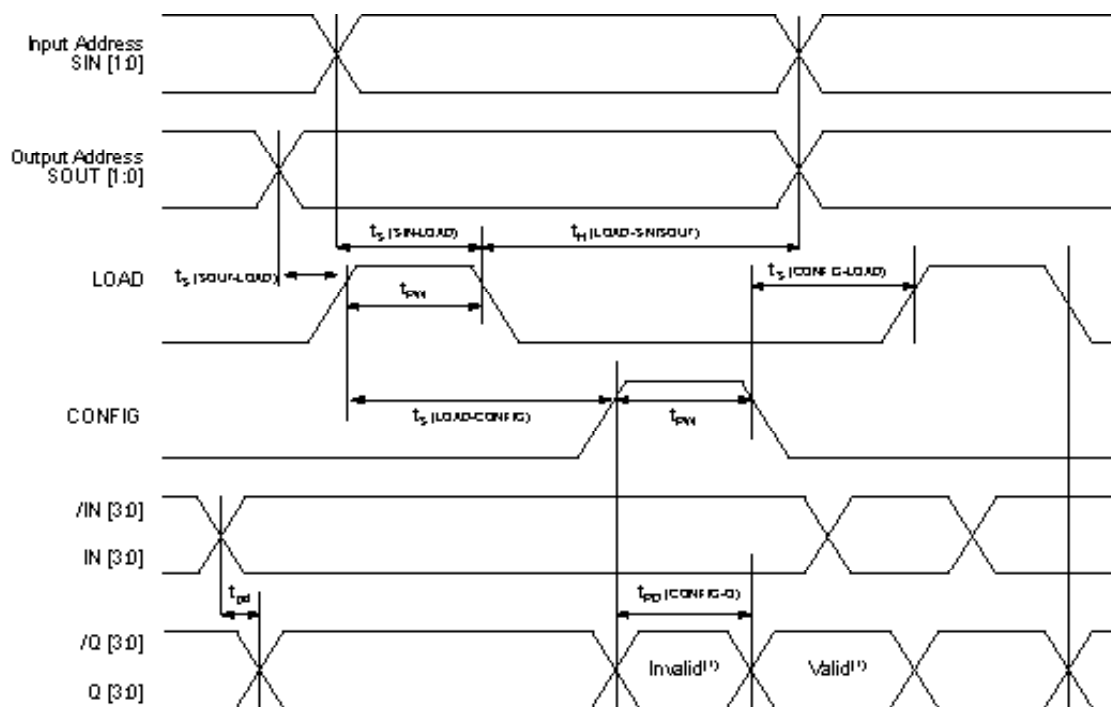


Figure 1b. Differential Voltage Swing

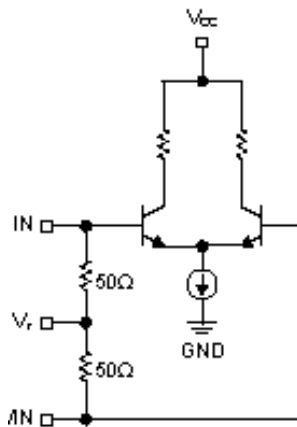
**TIMING DIAGRAM**



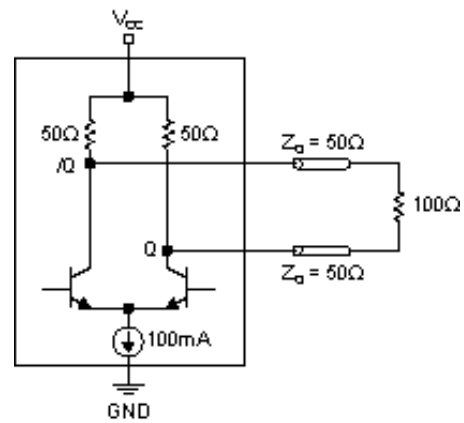
**Note:**

1. Invalid and Valid refers to onfiguration being changed. All outputs with unchanged configuration remain valid.

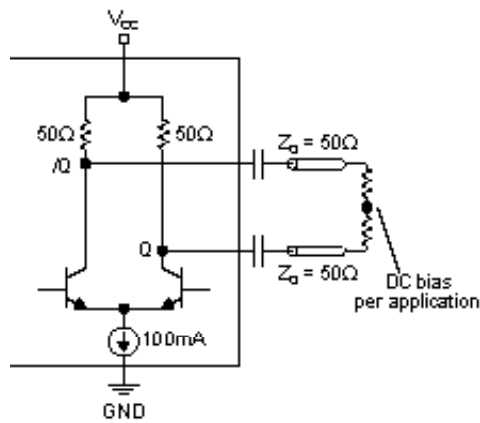
**INPUT AND OUTPUT STAGES**



**Figure 2a. Simplified Differential Input Stage**

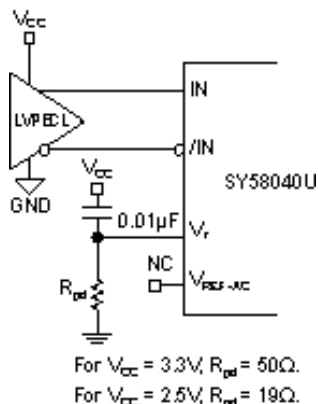


**Figure 2b. CML DC-Coupled (100Ω Termination)**

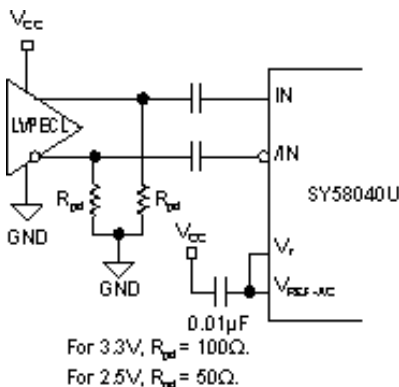


**Figure 2c. CML AC-Coupled (50Ω Termination)**

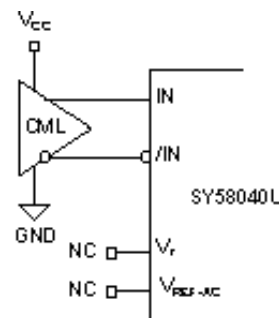
**INPUT INTERFACE APPLICATIONS**



**Figure 3a. LVPECL Interface (DC-Coupled)**

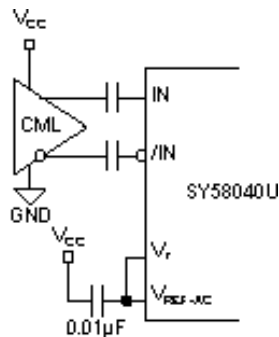


**Figure 3b. LVPECL Interface (AC-Coupled)**

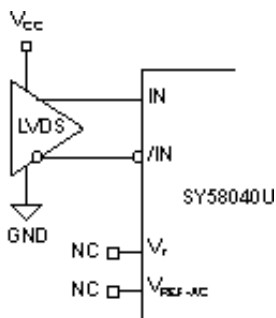


*Option: May connect  $V_T$  to  $V_{CC}$ .*

**Figure 3c. CML Interface (DC-Coupled)**



**Figure 3d. CML Interface (AC-Coupled)**

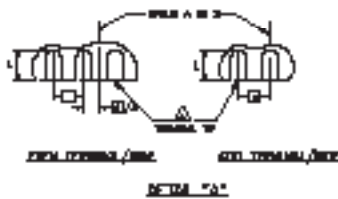
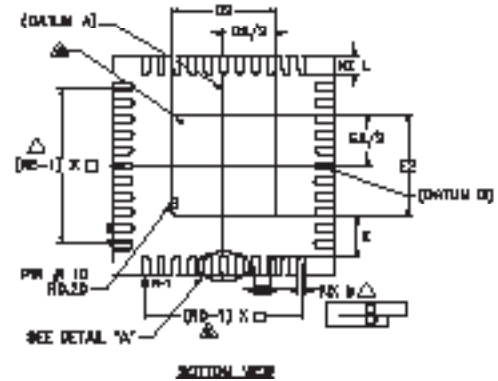
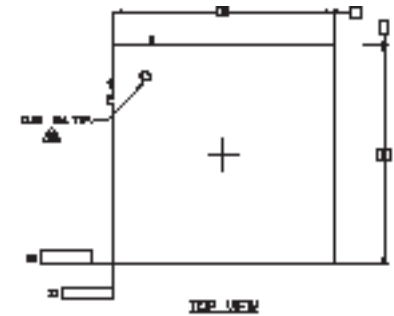


**Figure 3e. LVDS Interface**

**RELATED MICREL PRODUCTS AND SUPPORT DOCUMENTATION**

Part Number	Function	Data Sheet Link
SY58040U	Ultra Precision 4x4 CML Crosspoint Switch with Internal Input/Output Termination	<a href="http://www.micrel.com/product-info/products/sy58040u.shtml">http://www.micrel.com/product-info/products/sy58040u.shtml</a>
	MLF® Application Note	<a href="http://www.amkor.com/products/notes_paper/MLF_AppNote.pdf">www.amkor.com/products/notes_paper/MLF_AppNote.pdf</a>
HBW Solutions	New Products and Applications	<a href="http://www.micrel.com/product-info/products/solutions.shtml">www.micrel.com/product-info/products/solutions.shtml</a>

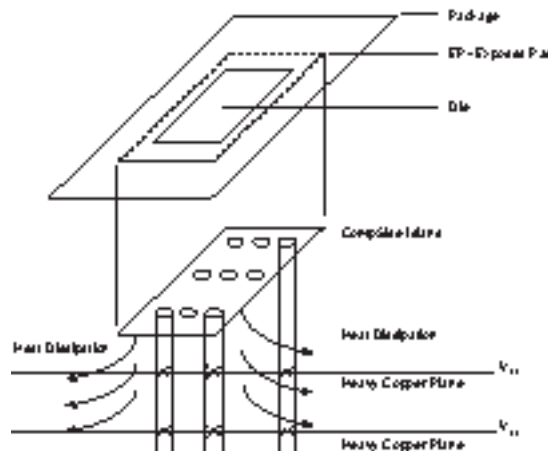
**44-PIN QFN (QFN-44)**



**NOTES :**

1. DIMENSIONING AND TOLERANCING CONFORM TO ASME Y14.5M - 1994.
2. ALL DIMENSIONS ARE IN MILLIMETERS, 0.010 DECIMAL.
3. N IS THE TOTAL NUMBER OF TERMINALS.
4. DIMENSION S APPLIES TO METALLIZED TERMINAL AND IS MEASURED BETWEEN 0.10 AND 0.20mm FROM TERMINAL TIP. IF THE TERMINAL HAS THE OPTIONAL RADIUS ON THE OTHER END OF THE TERMINAL, THE DIMENSION S SHOULD NOT BE MEASURED IN THAT RADIUS AREA AND WE REFER TO THE NUMBER OF TERMINALS ON EACH D AND E SIDE RESPECTIVELY.
5. MAX. PACKAGE WARPAGE IS 0.06 mm.
6. MAXIMUM ALLOWABLE BURR IS 0.075 mm IN ALL DIRECTIONS.
7. PIN #1 IS ON TOP WILL BE LASER MARKED.
8. BILATERAL COPPLANARITY CONE APPLIES TO THE EXPOSED HEAT SINK PAD AS WELL AS THE TERMINALS.
9. THIS DRAWING CONFORMS TO JEDEC REGISTERED OUTLINE MO-289

DIM.	DIMENSIONS			TOL.
	MIN.	NOM.	MAX.	
W		0.50	0.50	
N		44		3
N(D)		11		3
N(E)		11		3
L	0.100	0.60	0.65	
S	0.18	0.25	0.30	3
D2	3.25	3.25	3.40	
F2	3.25	3.30	3.40	
D		7.00	9.80	
E		7.00	9.80	
A	0.180	0.225	1.215	
A1	0.100	0.102	0.105	
K		0.20	MIN.	
Q	D		12	2



**PCB Thermal Consideration for 44-Pin QFN Package**  
(Always solder, or equivalent, the exposed pad to the PCB)

**Package Notes:**

1. Package meets Level 2 qualification.
2. All parts are dry-packaged before shipment.
3. Exposed pads must be soldered to a ground for proper thermal management.

**MICREL, INC. 2180 FORTUNE DRIVE SAN JOSE, CA 95131 USA**

TEL + 1 (408) 944-0800 FAX + 1 (408) 474-1000 WEB <http://www.micrel.com>

The information furnished by Micrel in this data sheet is believed to be accurate and reliable. However, no responsibility is assumed by Micrel for its use. Micrel reserves the right to change circuitry and specifications at any time without notification to the customer.

Micrel Products are not designed or authorized for use as components in life support appliances, devices or systems where malfunction of a product can reasonably be expected to result in personal injury. Life support devices or systems are devices or systems that (a) are intended for surgical implant into the body or (b) support or sustain life, and whose failure to perform can be reasonably expected to result in a significant injury to the user. A Purchaser's use or sale of Micrel Products for use in life support appliances, devices or systems is at Purchaser's own risk and Purchaser agrees to fully indemnify Micrel for any damages resulting from such use or sale.

© 2005 Micrel, Incorporated.



Компания «ЭлектроПласт» предлагает заключение долгосрочных отношений при поставках импортных электронных компонентов на взаимовыгодных условиях!

Наши преимущества:

- Оперативные поставки широкого спектра электронных компонентов отечественного и импортного производства напрямую от производителей и с крупнейших мировых складов;
- Поставка более 17-ти миллионов наименований электронных компонентов;
- Поставка сложных, дефицитных, либо снятых с производства позиций;
- Оперативные сроки поставки под заказ (от 5 рабочих дней);
- Экспресс доставка в любую точку России;
- Техническая поддержка проекта, помощь в подборе аналогов, поставка прототипов;
- Система менеджмента качества сертифицирована по Международному стандарту ISO 9001;
- Лицензия ФСБ на осуществление работ с использованием сведений, составляющих государственную тайну;
- Поставка специализированных компонентов (Xilinx, Altera, Analog Devices, Intersil, Interpoint, Microsemi, Aeroflex, Peregrine, Syfer, Eurofarad, Texas Instrument, Miteq, Cobham, E2V, MA-COM, Hittite, Mini-Circuits, General Dynamics и др.);

Помимо этого, одним из направлений компании «ЭлектроПласт» является направление «Источники питания». Мы предлагаем Вам помощь Конструкторского отдела:

- Подбор оптимального решения, техническое обоснование при выборе компонента;
- Подбор аналогов;
- Консультации по применению компонента;
- Поставка образцов и прототипов;
- Техническая поддержка проекта;
- Защита от снятия компонента с производства.



#### Как с нами связаться

**Телефон:** 8 (812) 309 58 32 (многоканальный)

**Факс:** 8 (812) 320-02-42

**Электронная почта:** [org@eplast1.ru](mailto:org@eplast1.ru)

**Адрес:** 198099, г. Санкт-Петербург, ул. Калинина, дом 2, корпус 4, литера А.