

General Specifications

Electrical Capacity (Resistive Load)

Power Level (silver): 3A @ 125V AC for low & medium security; 1A @ 250V AC for low security

Other Ratings

Contact Resistance: 10 milliohms maximum
Insulation Resistance: 1,000 megohms minimum @ 500V DC
Dielectric Strength: 1,000V AC minimum between contacts for 1 minute minimum;
 1,500V AC minimum between contacts & case for 1 minute minimum
Mechanical Life: 30,000 cycles minimum
Electrical Life: 10,000 cycles minimum
Nominal Operating Torque: .026Nm (.234 lb•in) for low & medium security
Contact Timing: Break-before-make
Angle of Throw: 90° for 2-position & 45° for 3-position

Materials & Finishes

Key: Zinc alloy with chrome plating (matte) for low security models;
 brass with nickel plating (shiny) for medium security models
Tumbler Barrel: Zinc alloy with chrome plating (matte) for low security models;
 zinc alloy with chrome plating (shiny) for medium security models
Housing/Bushing: Zinc alloy with chrome plating (matte) for low security models;
 zinc alloy with chrome plating (shiny) for medium security models
Base: Phenolic resin (thermoset)
Movable Contactor: Silver
Stationary Contacts: Silver capped copper with silver plating
Terminals: Copper or brass with silver plating

Environmental Data

Operating Temperature Range: -25°C through +70°C (-13°F through +158°F)
Humidity: 90 ~ 95% humidity for 96 hours @ 40°C (104°F)
Vibration: 10 ~ 55Hz with peak-to-peak amplitude of 1.5mm traversing the frequency range & returning in 1 minute; 3 right angled directions for 2 hours
Shock: 50G (490m/s²) acceleration (tested in 6 right angled directions, with 5 shocks in each direction)

Installation

Mounting Torque: 1.5Nm (13.28 lb•in) maximum
Soldering Time & Temperature: Manual Soldering: See Profile A in Supplement section.

Standards & Certifications

UL: **File No. E44145 - Recognized only when ordered with marking on switch.**
 Add "/U" or "/CUL" to end of part number to order UL recognized switch.
 All low security models recognized at 3A @ 125V AC or 1A @ 250V AC
 & all medium security models recognized at 3A @ 125V AC
CSA: **File No. 023535_0_000 - Certified only when ordered with marking on switch.**
 Add "/C" to end of part number to order CSA certified switch.
 All low security models certified at 3A @ 125V AC or 1A @ 250V AC

Distinctive Characteristics

12mm diameter bushing for easy panel cutout preparation and high density mounting.

Epoxy sealed terminals prevent entry of flux and other contaminants.

Short behind panel dimension - only 1.063" (27.0mm).

High dielectric strength of 1,500 volts between contacts and case.

Detent mechanism gives crisp, positive action for accurate switch setting.

Dust resistant interior construction protects contacts.

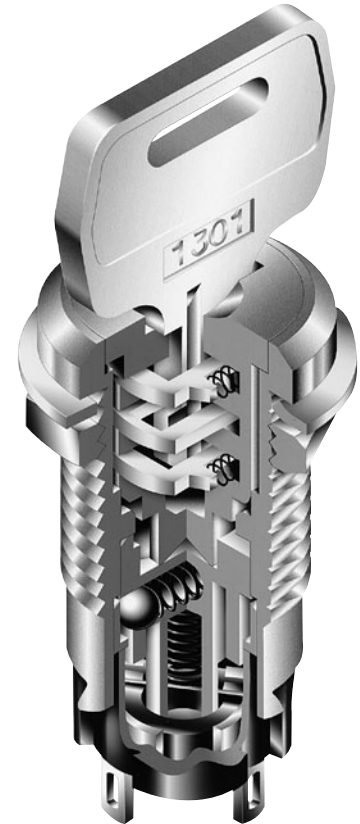

Actual Size

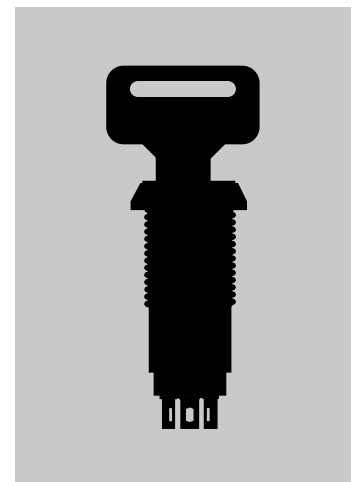

Toggles

Rockers

Pushbuttons

Illuminated PB

Programmable

F
Keylocks

Rotaries

Slides

Tactiles

Tilt

Touch

Indicators

Accessories

Supplement

TYPICAL SWITCH ORDERING EXAMPLE

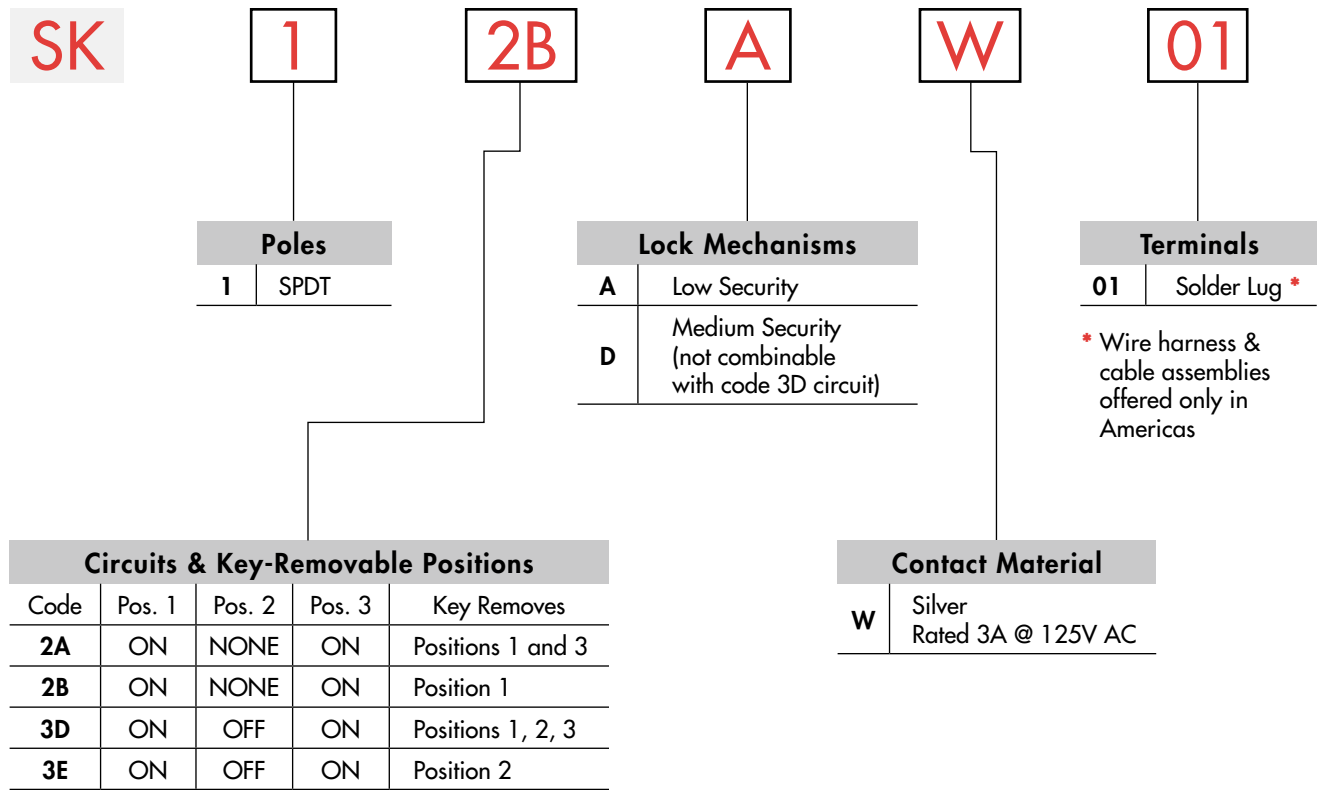

DESCRIPTION FOR TYPICAL ORDERING EXAMPLE

SK12BAW01

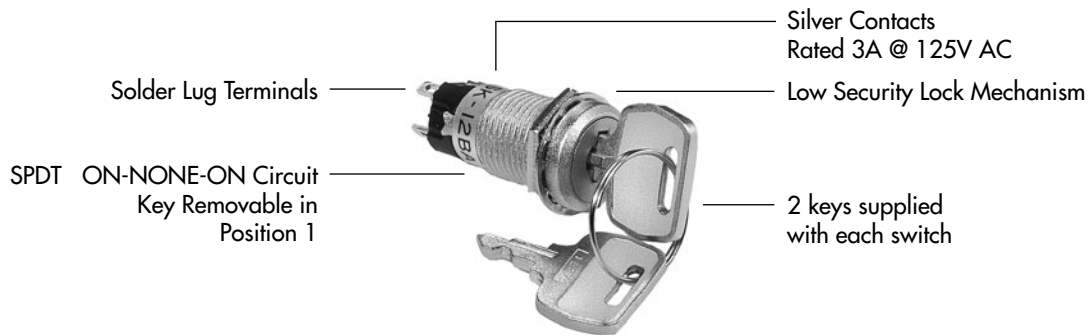

IMPORTANT:



Switches are supplied without UL, cULus & CSA marking unless specified. **UL, cULus & CSA recognized only when ordered with marking on the switch.** Specific models, ratings, & ordering instructions are noted on General Specifications page.

Toggles
 Rockers
 Pushbuttons
 Illuminated PB
 Programmable
 Keylocks
 Rotaries
 Slides
 Tactiles
 Tilt
 Touch
 Indicators
 Accessories
 Supplement

POLES, CIRCUITS & KEY-REMOVABLE POSITIONS

Pole & Throw	Model	Key Positions			Connected Terminals (Terminal numbers are on switch)			Schematic	⊙ = Key Removable ● = Not Removable ✓ = Maximum Arc
		Pos 1	Pos 2	Pos 3	Pos 1	Pos 2	Pos 3		
SPDT	SK12A	ON	NONE	ON	COM-1	—	COM-2		
SPDT	SK12B	ON	NONE	ON	COM-1	—	COM-2		
SPDT	*SK13D	ON	OFF	ON	COM-1	OPEN	COM-2		
SPDT	SK13E	ON	OFF	ON	COM-1	OPEN	COM-2		

* Available with low security only

KEY REMOVABLE

A Positions 1 & 3
90° Angular Throw

B Position 1
90° Angular Throw

D Positions 1, 2 & 3
45° Angular Throw

E Position 2
45° Angular Throw

LOCK MECHANISMS & KEYS

A Low Security Mechanism

Zinc Alloy with Chrome Plating (matte finish)

Two keys provided with each switch
(no master key available)

For ordering additional keys:
AT4081 for SK12A and SK12B, marked "1201"
AT4082 for SK13D and SK13E, marked "1301"

D Medium Security Mechanism

Brass with Nickel Plating (shiny finish)

One key provided with each switch
(no master key available)

For ordering additional keys, indicate the same key number that is engraved on the face of your switch.

Key numbers (001 through 010) randomly assigned.

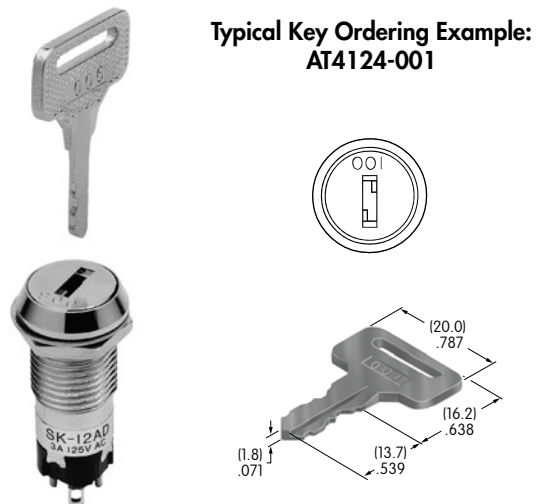
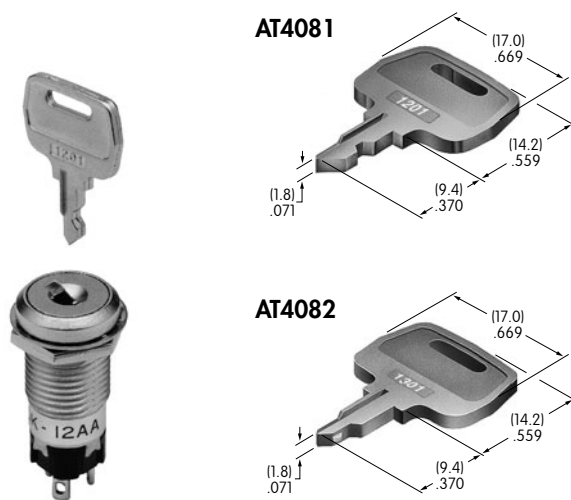

Toggle
Rockers
Pushbuttons
Illuminated PB
Programmable
Keylocks
Rotaries
Slides
Tactiles
Tilt
Touch
Indicators
Accessories
Supplement

CONTACT MATERIALS, RATINGS, & TERMINALS

W

Silver over Silver

Power Level

3A @ 125V AC

01

Solder Lug Terminals

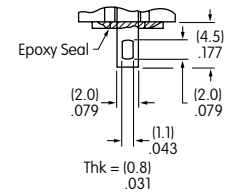

TYPICAL SWITCH DIMENSIONS

Low Security • 90° Angular Throw

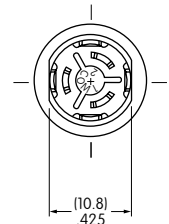
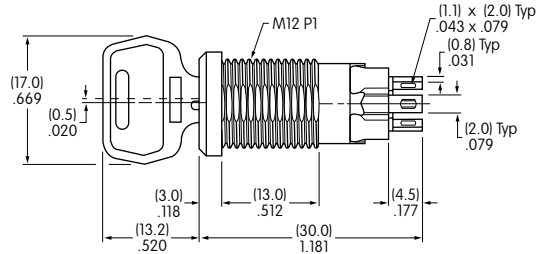
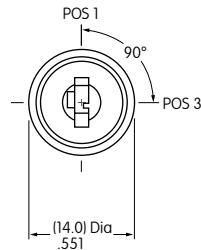

SK12BAW01

Low Security • 45° Angular Throw

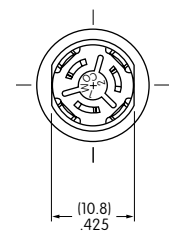
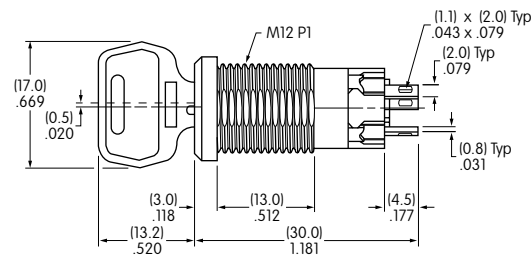
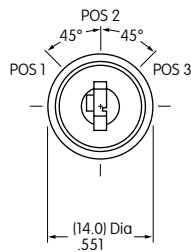

SK13EAW01

Toggles

Rockers

Pushbuttons

Illuminated PB

Programmable

Keylocks

Rotaries

Slides

Tactiles

Tilt

Touch

Indicators

Accessories

Supplement

TYPICAL SWITCH DIMENSIONS

Medium Security • 90° Angular Throw

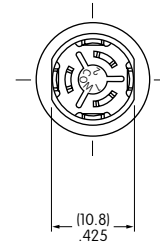
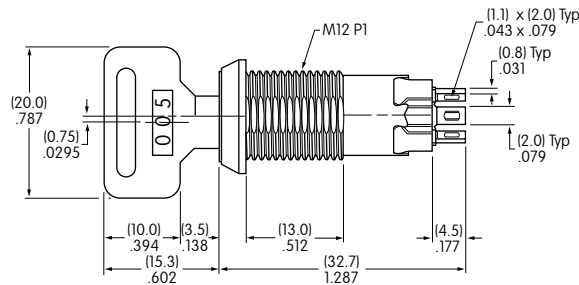
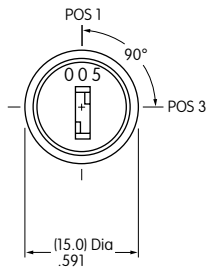

SK12ADW01

Medium Security • 45° Angular Throw

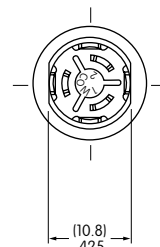
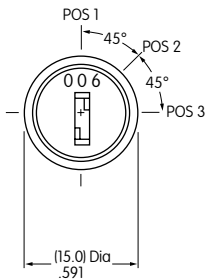

SK13EDW01

PANEL CUTOUT & THICKNESS

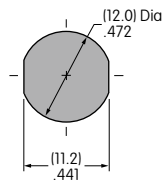

The 12mm bushing is .512" (13.0mm) long. It allows mounting these devices in a maximum effective panel thickness of .315" (8.0mm).

STANDARD HARDWARE

AT527M Hex Mounting Nut

1 included with each switch

Steel with nickel plating

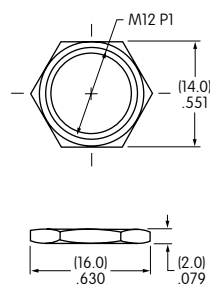

AT508 Internal Tooth Lockwasher

1 included with each switch

Steel with zinc/chromate plating

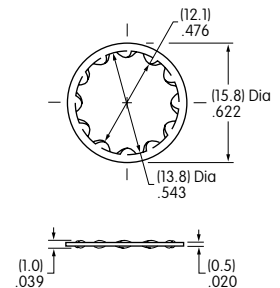



Компания «ЭлектроПласт» предлагает заключение долгосрочных отношений при поставках импортных электронных компонентов на взаимовыгодных условиях!

Наши преимущества:

- Оперативные поставки широкого спектра электронных компонентов отечественного и импортного производства напрямую от производителей и с крупнейших мировых складов;
- Поставка более 17-ти миллионов наименований электронных компонентов;
- Поставка сложных, дефицитных, либо снятых с производства позиций;
- Оперативные сроки поставки под заказ (от 5 рабочих дней);
- Экспресс доставка в любую точку России;
- Техническая поддержка проекта, помощь в подборе аналогов, поставка прототипов;
- Система менеджмента качества сертифицирована по Международному стандарту ISO 9001;
- Лицензия ФСБ на осуществление работ с использованием сведений, составляющих государственную тайну;
- Поставка специализированных компонентов (Xilinx, Altera, Analog Devices, Intersil, Interpoint, Microsemi, Aeroflex, Peregrine, Syfer, Eurofarad, Texas Instrument, Miteq, Cobham, E2V, MA-COM, Hittite, Mini-Circuits, General Dynamics и др.);

Помимо этого, одним из направлений компании «ЭлектроПласт» является направление «Источники питания». Мы предлагаем Вам помощь Конструкторского отдела:

- Подбор оптимального решения, техническое обоснование при выборе компонента;
- Подбор аналогов;
- Консультации по применению компонента;
- Поставка образцов и прототипов;
- Техническая поддержка проекта;
- Защита от снятия компонента с производства.



Как с нами связаться

Телефон: 8 (812) 309 58 32 (многоканальный)

Факс: 8 (812) 320-02-42

Электронная почта: org@eplast1.ru

Адрес: 198099, г. Санкт-Петербург, ул. Калинина, дом 2, корпус 4, литера А.