

## PROTECTION PRODUCTS - MicroClamp™

### Description

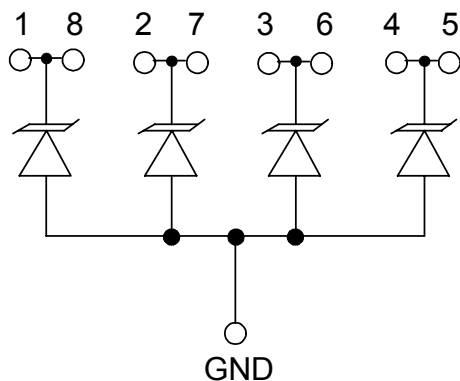
The  $\mu$ Clamp™ series of TVS arrays are designed to protect sensitive electronics from damage or latch-up due to ESD, lightning, and other voltage-induced transient events. Each device will protect up to four lines operating at **3.3 volts**.

The  $\mu$ Clamp™3324P is a solid-state device designed specifically for transient suppression. It is constructed using Semtech's proprietary EPD process technology. The EPD process provides low standoff voltages with significant reductions in leakage currents and capacitance over traditional pn junction processes. They offer desirable characteristics for board level protection including fast response time, low clamping voltage and no device degradation.

The  $\mu$ Clamp3324P may be used to meet the immunity requirements of IEC 61000-4-2, level 4 ( $\pm 15$ kV air,  $\pm 8$ kV contact discharge). The "flow-thru" design of the device results in enhanced ESD performance due to reduced board trace inductance. The result is lower clamping voltage and a higher level of protection when compared to conventional TVS devices.

The  $\mu$ Clamp3324P is in an 8-pin, RoHs compliant, SLP2116P8 package. It measures 2.1 x 1.6 x 0.58mm. The leads are spaced at a pitch of 0.5mm and are finished with lead-free NiPd. The small package makes it ideal for use in portable electronics such as cell phones, digital still cameras, and notebook computers.

### Circuit Diagram



**Device Schematic**

### Features

- ◆ Transient protection for data lines to **IEC 61000-4-2 (ESD)  $\pm 15$ kV (air),  $\pm 8$ kV (contact)**  
**IEC 61000-4-4 (EFT) 40A (tp = 5/50ns)**
- ◆ Small package for use in portable electronics
- ◆ Protects four I/O
- ◆ Working voltage: 3.3V
- ◆ Flow thru design for easy layout
- ◆ Low leakage current
- ◆ Low operating and clamping voltages
- ◆ Solid-state silicon-avalanche technology

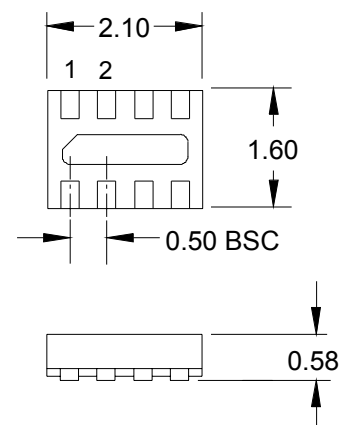
### Mechanical Characteristics

- ◆ SLP2116P8 package
- ◆ RoHs Compliant
- ◆ Nominal Dimensions: 2.1 x 1.6 x 0.58 mm
- ◆ Lead Pitch: 0.5mm
- ◆ Lead Finish: NiPd
- ◆ Marking : Orientation Mark and Marking Code
- ◆ Packaging : Tape and Reel per EIA 481

### Applications

- ◆ Cellular Handsets & Accessories
- ◆ Personal Digital Assistants (PDA's)
- ◆ Notebooks & Handhelds
- ◆ Portable Instrumentation
- ◆ Digital Cameras
- ◆ Peripherals
- ◆ MP3 Players

### Package



**8 Pin SLP package (Bottom Side View)**  
**2.1 x 1.6 x 0.58mm (Nominal)**

## PROTECTION PRODUCTS

### Absolute Maximum Rating

Rating	Symbol	Value	Units
Peak Pulse Power (tp = 8/20μs)	$P_{pk}$	40	Watts
Maximum Peak Pulse Current (tp = 8/20μs)	$I_{pp}$	5	Amps
ESD per IEC 61000-4-2 (Air) ESD per IEC 61000-4-2 (Contact)	$V_{pp}$	+/- 20 +/- 15	kV
Operating Temperature	$T_J$	-55 to +125	°C
Storage Temperature	$T_{STG}$	-55 to +150	°C

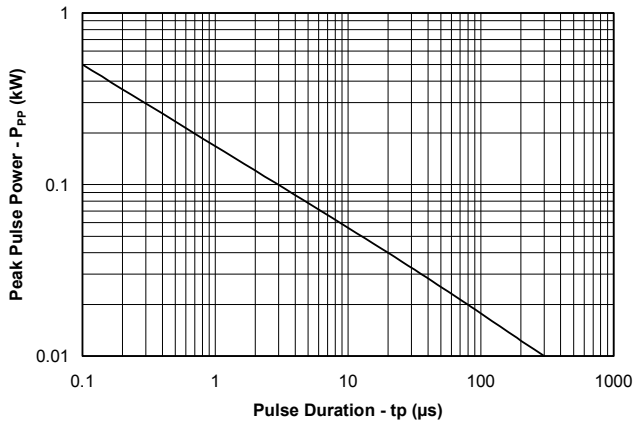
### Electrical Characteristics (T=25°C)

Parameter	Symbol	Conditions	Minimum	Typical	Maximum	Units
Reverse Stand-Off Voltage	$V_{RWM}$				3.3	V
Punch-Through Voltage	$V_{PT}$	$I_{PT} = 2\mu A$	3.5			V
Snap-Back Voltage	$V_{SB}$	$I_{SB} = 50mA$	2.8			V
Reverse Leakage Current	$I_R$	$V_{RWM} = 3.3V$		0.05	0.5	μA
Clamping Voltage	$V_C$	$I_{pp} = 1A$ , tp = 8/20μs Any I/O to Gnd			5.5	V
Clamping Voltage	$V_C$	$I_{pp} = 5A$ , tp = 8/20μs Any I/O to Gnd			8.0	V
Reverse Clamping Voltage	$V_{CR}$	$I_{pp} = 1A$ , tp = 8/20μs Any I/O to Gnd			2.4	V
Junction Capacitance	$C_J$	I/O pin to Gnd $V_R = 0V$ , f = 1MHz		25	30	pF
		I/O pin to Gnd $V_R = 3.3V$ , f = 1MHz		14		pF

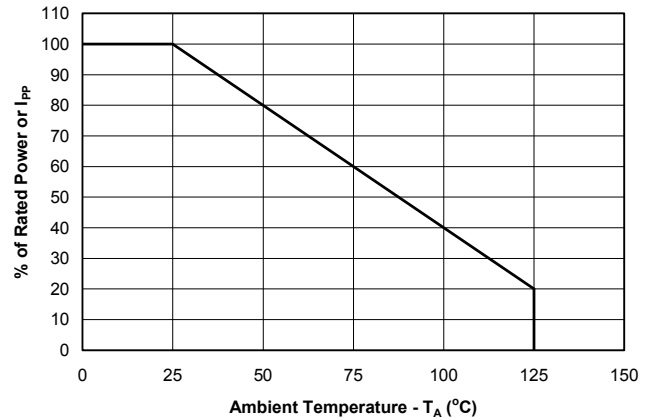
## PROTECTION PRODUCTS

### Typical Characteristics

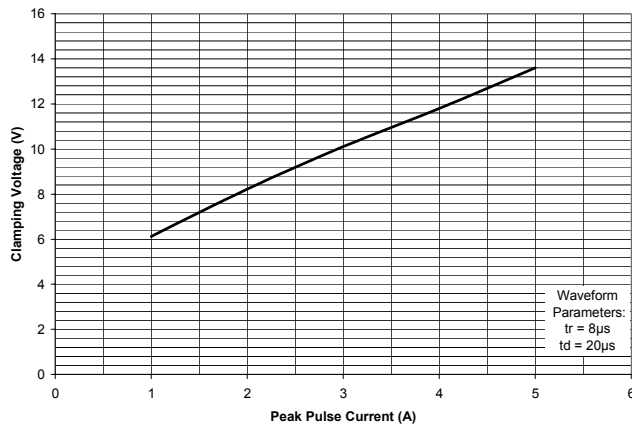
#### Non-Repetitive Peak Pulse Power vs. Pulse Time



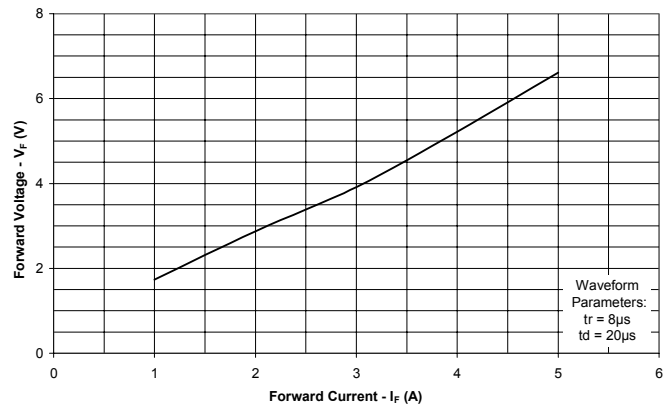
#### Power Derating Curve



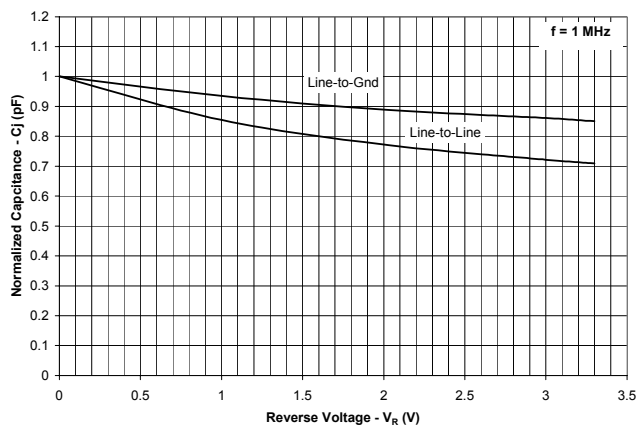
#### Clamping Voltage vs. Peak Pulse Current



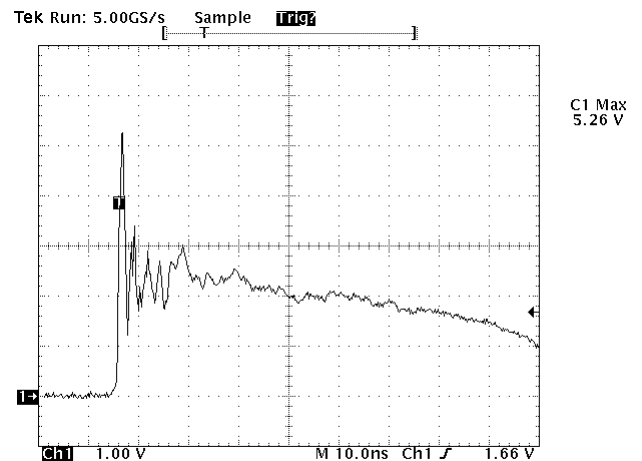
#### Forward Voltage vs. Forward Current



#### Junction Capacitance vs. Reverse Voltage



#### ESD Clamping (8kV Contact per IEC 61000-4-2)



## PROTECTION PRODUCTS

### Applications Information

#### Device Connection Options

The  $\mu$ Clamp3324P is designed to protect four lines. It will present a high impedance to the protected line up to 3.3 volts. It will “turn on” when the line voltage exceeds 3.5 volts. The device is unidirectional and may be used on lines where the signal polarity is above ground.

#### Flow Thru Layout

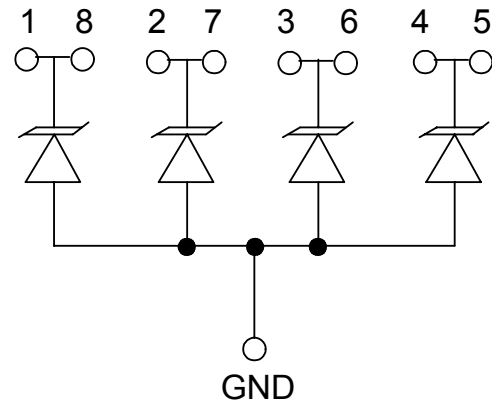
The  $\mu$ Clamp3324P is designed for ease of PCB layout by allowing the traces to enter one side of the device and exit the other side. Figure 2 shows the recommended way to design the PCB board traces in order to use the flow through layout. The solid line represents the PCB trace. Note that the PCB traces enter at the input pin and exit from the opposite pin. (pin 1 to pin 8, pin 2 to pin 9, pin 3 to pin 6, pin 4 to pin 5). For example, line 1 enters at pin 1 and exits at Pin 8. The bottom tab is connected to ground. This connection should be made directly to a ground plane on the board for best results. The path length is kept as short as possible to minimize parasitic inductance.

#### EPD TVS Characteristics

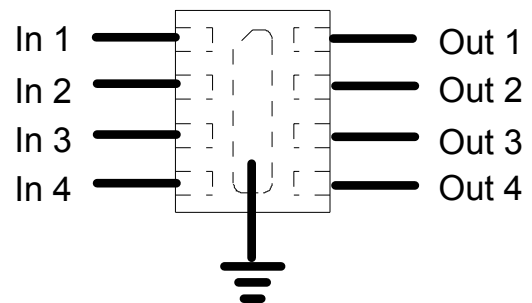
These devices are constructed using Semtech’s proprietary EPD technology. The structure of the EPD TVS is vastly different from the traditional pn-junction devices. At voltages below 5V, high leakage current and junction capacitance render conventional avalanche technology impractical for most applications. However, by utilizing the EPD technology, these devices can effectively operate at 3.3V while maintaining excellent electrical characteristics.

The EPD TVS employs a complex npnp structure in contrast to the pn structure normally found in traditional silicon-avalanche TVS diodes. The EPD mechanism is achieved by engineering the center region of the device such that the reverse biased junction does not avalanche, but will “punch-through” to a conducting state. This structure results in a device with superior DC electrical parameters at low voltages while maintaining the capability to absorb high transient currents.

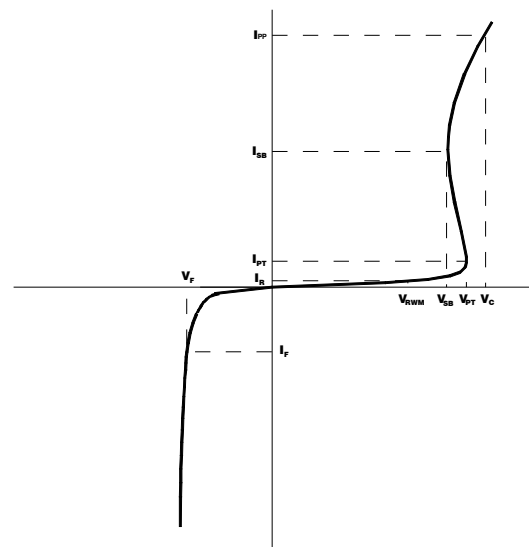
**Figure 1 - Circuit Diagram**



**Figure 2 - Layout Example**

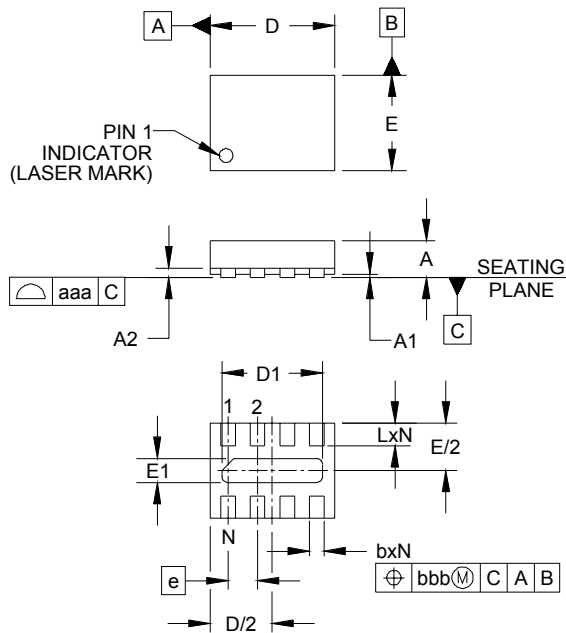


**Figure 3 - EPD TVS IV Characteristic Curve**



PROTECTION PRODUCTS

Outline Drawing - SLP2116P8

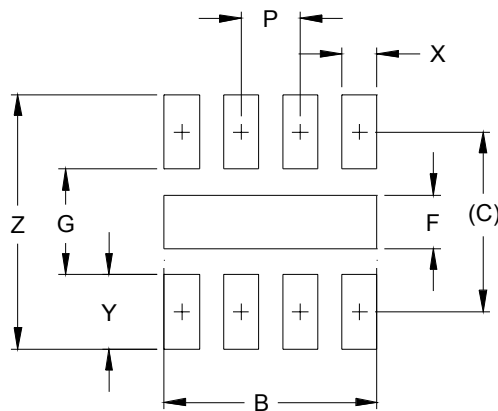


DIM	INCHES			MILLIMETERS		
	MIN	NOM	MAX	MIN	NOM	MAX
A	.020	.023	.026	0.50	0.58	0.65
A1	-	.001	.002	0.00	.003	0.05
A2	(.006)			(0.15)		
b	.007	.010	.012	0.20	0.25	0.30
D	.079	.083	.087	2.00	2.10	2.20
D1	.061	.067	.071	1.55	1.70	1.80
E	.059	.063	.067	1.50	1.60	1.70
E1	.010	.016	.020	0.25	0.40	0.50
e	.020 BSC			0.50 BSC		
L	.011	.013	.015	0.28	0.33	0.38
N	6			6		
aaa	.003			0.08		
bbb	.004			0.10		

NOTES:

1. CONTROLLING DIMENSIONS ARE IN MILLIMETERS (ANGLES IN DEGREES).
2. COPLANARITY APPLIES TO THE EXPOSED PAD AS WELL AS THE TERMINALS.

Land Pattern - SLP2116P8



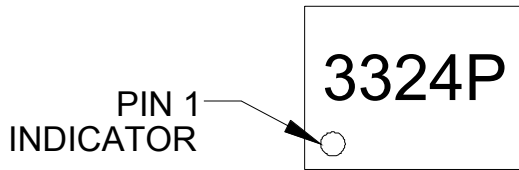
DIM	DIMENSIONS	
	INCHES	MILLIMETERS
B	.071	1.80
C	.060	1.52
F	.018	0.45
G	.035	0.89
P	.020	0.50
X	.012	0.30
Y	.025	0.63
Z	.085	2.15

NOTES:

1. THIS LAND PATTERN IS FOR REFERENCE PURPOSES ONLY. CONSULT YOUR MANUFACTURING GROUP TO ENSURE YOUR COMPANY'S MANUFACTURING GUIDELINES ARE MET.

## PROTECTION PRODUCTS

### Marking

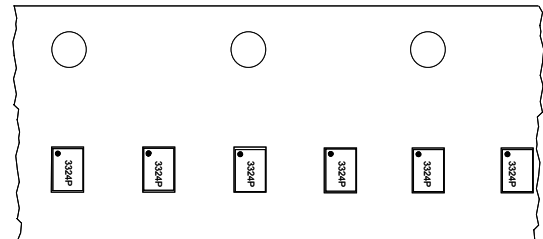
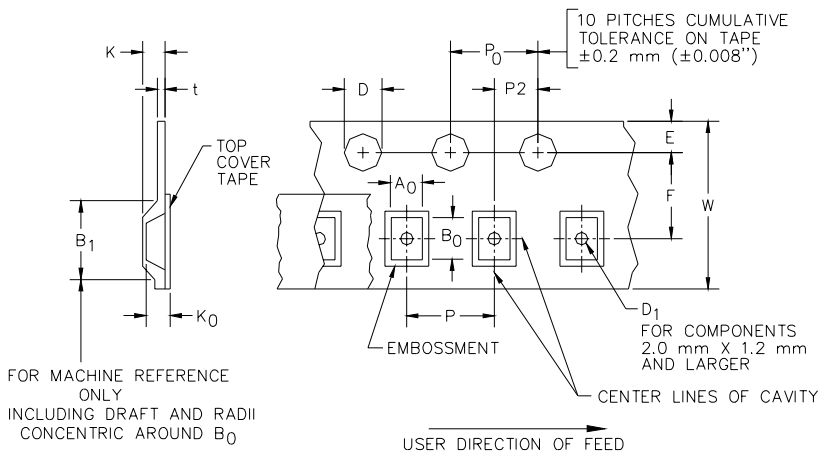


### Ordering Information

Part Number	Working Voltage	Device Marking	Qty per Reel	Reel Size
uClamp3324P.TCT	3.3V	3324P	3,000	7 Inch

MicroClamp, uClamp and  $\mu$ Clamp are marks of Semtech Corporation

### Tape and Reel Specification



**Device Orientation in Tape**

A0	B0	K0
1.96 +/-0.05 mm	2.31 +/-0.05 mm	0.74 +/-0.05 mm

Tape Width	B, (Max)	D	D1	E	F	K (MAX)	P	P0	P2	T(MAX)	W
8 mm	4.2 mm (.165)	1.5 + 0.1 mm - 0.0 mm (0.59 +.005 - .000)	0.8 mm ±0.05 (.031)	1.750±.10 mm (.069±.004)	3.5±0.05 mm (.138±.002)	2.4 mm (.094)	4.0±0.1 mm (.157±.004)	4.0±0.1 mm (.157±.004)	2.0±0.05mm (.079±.002)	0.4 mm (.016)	8.0 mm + 0.3 mm - 0.1 mm (.312±.012)

### Contact Information

Semtech Corporation  
 Protection Products Division  
 200 Flynn Road, Camarillo, CA 93012  
 Phone: (805)498-2111 FAX (805)498-3804

# Mouser Electronics

Authorized Distributor

Click to View Pricing, Inventory, Delivery & Lifecycle Information:

[Semtech:](#)

[UCLAMP3324P.TCT](#)



Компания «ЭлектроПласт» предлагает заключение долгосрочных отношений при поставках импортных электронных компонентов на взаимовыгодных условиях!

Наши преимущества:

- Оперативные поставки широкого спектра электронных компонентов отечественного и импортного производства напрямую от производителей и с крупнейших мировых складов;
- Поставка более 17-ти миллионов наименований электронных компонентов;
- Поставка сложных, дефицитных, либо снятых с производства позиций;
- Оперативные сроки поставки под заказ (от 5 рабочих дней);
- Экспресс доставка в любую точку России;
- Техническая поддержка проекта, помощь в подборе аналогов, поставка прототипов;
- Система менеджмента качества сертифицирована по Международному стандарту ISO 9001;
- Лицензия ФСБ на осуществление работ с использованием сведений, составляющих государственную тайну;
- Поставка специализированных компонентов (Xilinx, Altera, Analog Devices, Intersil, Interpoint, Microsemi, Aeroflex, Peregrine, Syfer, Eurofarad, Texas Instrument, Miteq, Cobham, E2V, MA-COM, Hittite, Mini-Circuits, General Dynamics и др.);

Помимо этого, одним из направлений компании «ЭлектроПласт» является направление «Источники питания». Мы предлагаем Вам помощь Конструкторского отдела:

- Подбор оптимального решения, техническое обоснование при выборе компонента;
- Подбор аналогов;
- Консультации по применению компонента;
- Поставка образцов и прототипов;
- Техническая поддержка проекта;
- Защита от снятия компонента с производства.



#### Как с нами связаться

**Телефон:** 8 (812) 309 58 32 (многоканальный)

**Факс:** 8 (812) 320-02-42

**Электронная почта:** [org@eplast1.ru](mailto:org@eplast1.ru)

**Адрес:** 198099, г. Санкт-Петербург, ул. Калинина, дом 2, корпус 4, литера А.