

## MICRO SWITCH Key Actuated Safety Switches

GKE Series

004738

Issue 2

Datasheet



### DESCRIPTION

The Honeywell GKE Series key-operated safety interlocking limit switches are designed for machine guarding applications. The switches mount on the EN50047 mounting pattern of the 20 mm to 22mm mounting centers. The compact size is preferred where there is limited space on machinery. The double-insulated plastic housing and rugged stainless steel actuator key is a logical choice for demanding environments. The design of the switch allows the actuator key to be inserted from the top or side of the switch. As with the Honeywell safety limit switches, all normally closed contacts are positive opening .

### FEATURES

- Red switch body for easy safety recognition
- 20 mm to 22 mm mounting centers per EN50047 which accept M4 or #8 mounting hardware
- Different contact options; 1NC (normally closed) and 1NO (normally open) or 2NC
- All NC contacts are positive opening  to EN/IEC 60947-5-1-3 specification
- Actuator head can be indexed in any of four positions, in 90° increments
- Switch chamber sealed to IP66/IP67 and NEMA 1, 4X (indoor), 12, 13
- CE, CCC, and cULus certifications for global applications
- Different threaded conduit options
- Designed and agency evaluated, per SIRA, for safety functions up to and including a SIL3 level

### POTENTIAL APPLICATIONS

- Safety interlock for guards or doors on equipment and machinery
- Designed for hinge or sliding guards or doors

### DIFFERENTIATION

- Switch design with dual entry (side or top) for actuator key
- Compact size of 31 mm L x 33 mm W x 96 mm H [1.2 in L x 1.3 in W x 3.8 in H]
- Rigid or flexible stainless steel actuator keys

### PORTFOLIO

In addition to the GKE Series safety interlocking limit switches, Honeywell offers other safety interlocking limit switches. These include the miniature plastic body GKM Series, the compact plastic body GKN Series, EN50041 metal body GKB Series, and metal body solenoid (trapped key) GKL/R Series. Non-interlocking safety limit switches include the metal body GSS Series, metal and plastic body non-contact FF Series, metal body 1CPS Series and 2CPS Series cable/rope pull safety limit switches.

# Key-Actuated Safety Switches, GKE Series

**Table 1. Performance Specifications**

| Characteristic   | Parameter   |
|--|---|
| <b>Description</b>                                       | Dual entry key-operated safety interlock switch   |
| <b>Agency certifications</b>                             | CE, DOC A340<br>cULus, File E37138<br>CCC, Certificate # 2011010305489827<br>SIL, Reference SIRA FSP 09009/02 |
| <b>Housing material</b>                                  | Glass-filled thermoplastic polyester  |
| <b>Actuator key material</b>                             | Stainless steel   |
| <b>Electrical connection</b>                             | 20 mm or 0.5-14 NPT conduit with each wiring point in switch a threaded terminal screw                        |
| <b>Contact/switch options<sup>1</sup></b>                | 1NC/1NO slow action BBM, 1NC/1NO snap action, 2NC slow action   |
| <b>Contact design</b>                                    | Double break, electrically separated (Zb)   |
| <b>Contact material</b>                                  | Silver alloy  |
| <b>Electrical ratings</b>                                | See table 2   |
| <b>Utilization category</b>                              | 1NC/1NO: AC-15, A600; DC13-Q300<br>2NC: AC-15, A300; DC13-Q300  |
| <b>Rated operational voltage (U<sub>e</sub>)</b>         | 1NC/1NO: 120 Vac, 240 Vac, 600 Vac, 125 Vdc, 250 Vdc<br>2NC: 120 Vac, 240 Vac, 125 Vdc, 250 Vdc               |
| <b>Rated operational current (I<sub>e</sub>)</b>         | 1NC/1NO: 6 A, 3 A, 1.2A, 0.55, 0.27<br>2NC: 6 A, 3 A, 0.55 A, 0.27 A  |
| <b>Thermal current (I<sub>th</sub>)</b>                  | 10 A  |
| <b>Rated insulation (U<sub>i</sub>)</b>                  | 1NC/1NO: 600 V<br>2NC: 300 V  |
| <b>Rated impulse withstand voltage (U<sub>imp</sub>)</b> | 2500 V  |
| <b>Short circuit protection device (SCPD)</b>            | Class J fuse, 10 A/600 V  |
| <b>Pollution degree</b>                                  | 3   |
| <b>Environmental sealing</b>                             | IP 66/67; NEMA 1, 4X (Indoor), 12, 13   |
| <b>Operating temperature</b>                             | -25° C to 85° C [-13° F to 185° F]  |
| <b>Shock</b>   | 50 g per IEC 60068-2-27   |
| <b>Vibration</b>   | 10 g per IEC 60068-2-6  |
| <b>MCTF (Mechanical life)</b>                            | 15,930,000 cycles   |
| <b>MCTF (Electrical life)</b>                            | >25,000 cycles with single-sided confidence limit of 75%  |
| <b>SIL Capability<sup>2</sup></b>                        | SIL3 capable with HFT=1 with reference to IEC 61508-2:2010 functional safety                                  |
| <b>Proof test interval</b>                               | 1 year  |

<sup>1</sup>All normally closed contacts are positive opening 

<sup>2</sup>HFT (Hardware Fault Tolerance).

**Table 2. Electrical Ratings**

| Designation and Utilization Category |             | Rated Operational Current I <sub>e</sub> (A) at Rated Operational Voltage U <sub>e</sub> (V) |        |        |       |       |       |       |
|--------------------------------------|-------------|--|--------|--------|-------|-------|-------|-------|
|                                      |             | 24 V   | 120 V  | 240 V  | 380 V | 480 V | 500 V | 600 V |
| <b>AC-15</b>                         | <b>A300</b> | –  | 6 A    | 3 A    | –     | –     | –     | –     |
| <b>AC-15</b>                         | <b>A600</b> | –  | 6 A    | 3 A    | 1.9 A | 1.5 A | 1.4 A | 1.2 A |
| <b>DC-13</b>                         | <b>Q300</b> | 2.8 A  | 0.55 A | 0.27 A | –     | –     | –     | –     |

# Key-Actuated Safety Switches, GKE Series

Figure 1. Product Nomenclature

| <b>GKE</b>  | <b>A</b>            | <b>03</b>                          | <b>L</b>                          |
|---|---------------------|------------------------------------|-----------------------------------|
| Switch Type   | Conduit             | Circuitry                          | Head Actuation Code <sup>1</sup>  |
| <b>GKE Series</b><br>Key-operated<br>safety limit<br>switch | <b>A</b> 0.5-14 NPT | <b>01</b> 1NC/1NO, snap action     | <b>L</b> Opening to front and top |
|   | <b>C</b> 20 mm      | <b>03</b> 1NC/1NO slow action, BBM | <b>M</b> Opening to right and top |
|   |                     | <b>06</b> 2NC slow action          | <b>N</b> Opening to back and top  |
|   |                     |                                    | <b>P</b> Opening to left and top  |

|                                 |                      |
|---------------------------------|----------------------|
| <b>Keys<sup>2</sup> Listing</b> | <b>Key style</b>     |
| GKZ51M                          | Straight             |
| GKZ52M                          | 90°                  |
| GKZ53M                          | Side/side adjustable |
| GKZ54M                          | Up/down adjustable   |
| GKZ55M                          | Multi-directional    |

<sup>1</sup> Actuator head can be field adjusted in increments of 90°. Order GKZT15 bit Torx tamper-resistant bit.  
<sup>2</sup> A key actuator (ordered separately) is required for each switch.

NOTE: For other switch options, please contact your Honeywell provider/representative for assistance.

Table 3. Circuitry Diagrams<sup>3</sup>

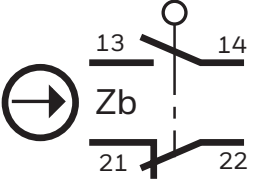
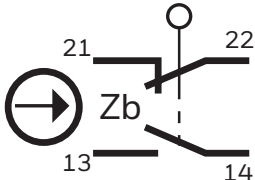
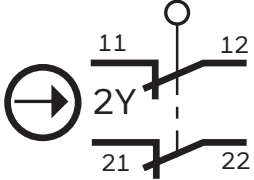
| Circuitry Type:<br>01 • Snap-action contacts                                       | Circuitry Type:<br>03 • Slow-action contacts                                       | Circuitry Type: 06 • 2NC slow-action contacts (normally closed)                      |
|--|--|--|
|  |  |  |

<sup>3</sup> Refer to circuitry in product nomenclature (Figure 1).

Table 4. Order Guide

|   | Catalog Listing <sup>1</sup> | Contacts                 | Electrical Connection/Conduit |
|---|------------------------------|--------------------------|-------------------------------|
|  | GKEA01L                      | 1NC/1NO snap-action      | 0.5-14 NPT                    |
|   | GKEC01L                      | 1NC/1NO snap-action      | 20 mm                         |
|   | GKEA03L                      | 1NC/1NO slow action, BBM | 0.5-14 NPT                    |
|   | GKEC03L                      | 1NC/1NO slow action, BBM | 20 mm                         |
|   | GKEA06L                      | 2NC slow action          | 0.5-14 NPT                    |
|   | GKEC06L                      | 2NC slow action          | 20 mm                         |

<sup>1</sup> An actuator key (ordered separately) is required for each switch. Select actuator key by reviewing product nomenclature tree and dimensional diagrams on pages 3 and 5.

# Key-Actuated Safety Switches, GKE Series

Figure 3. Product Dimensions mm [in]

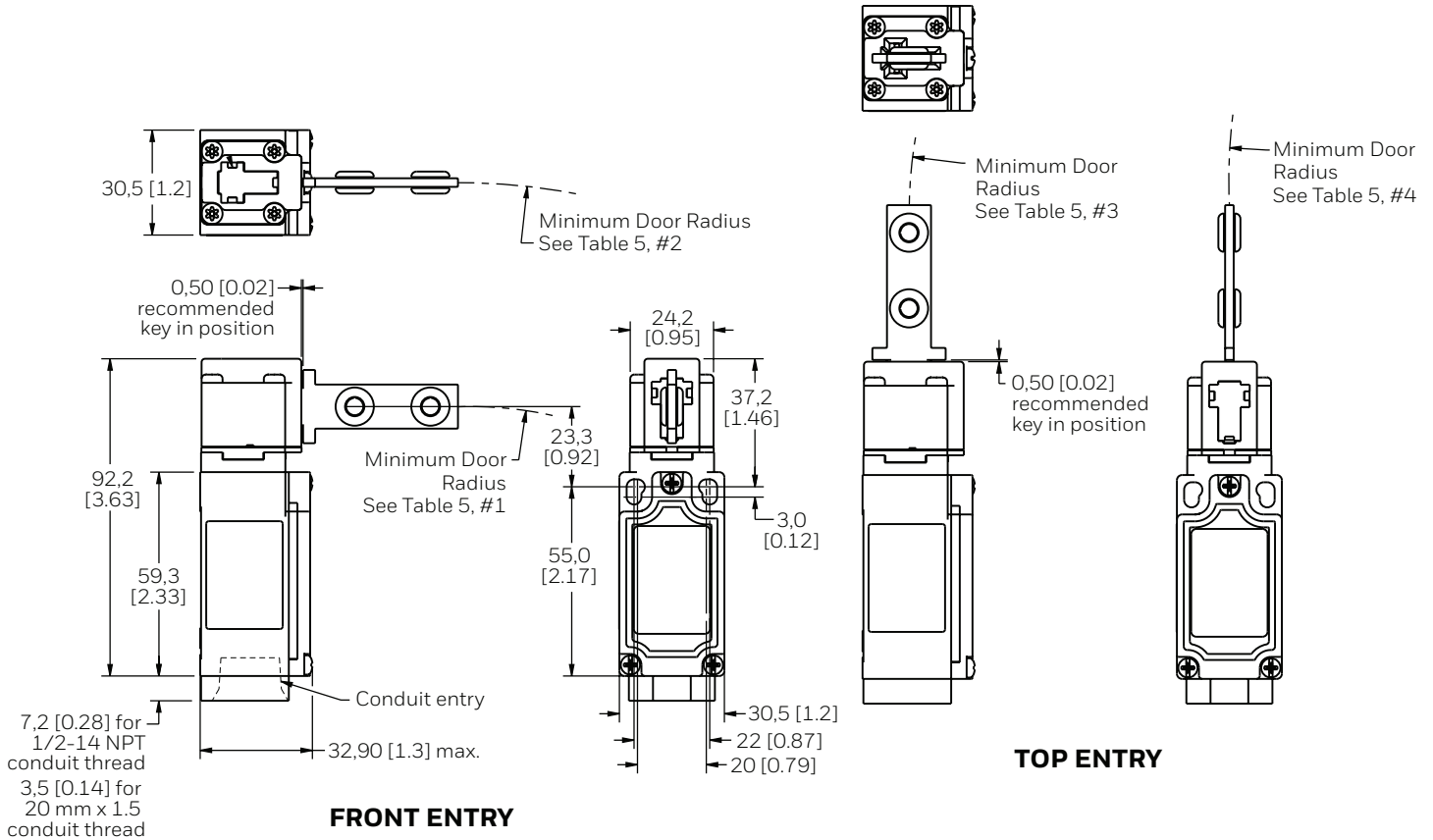
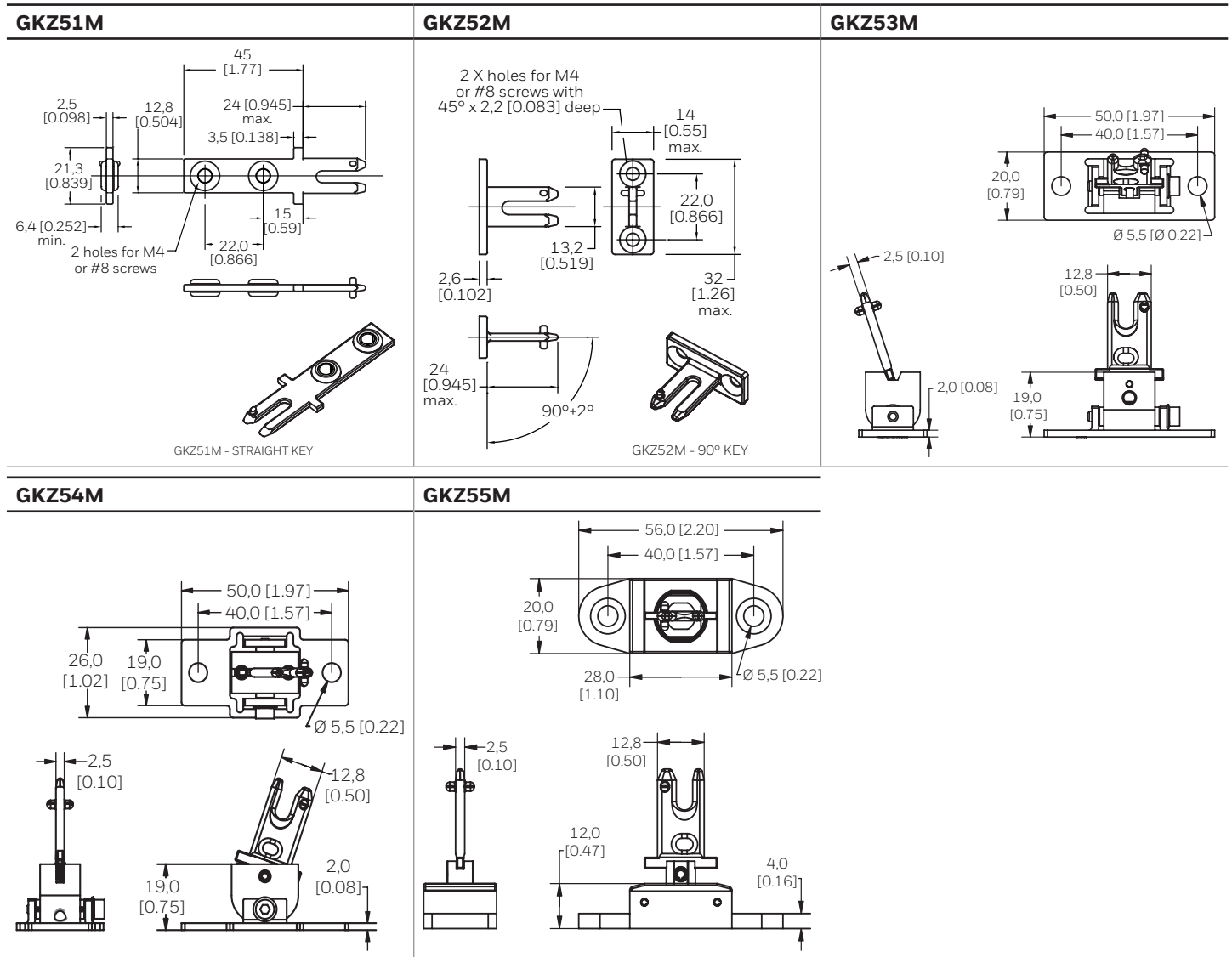

Table 5. Minimum Actuating Radius

| Catalog Listing, Description              | Front Entry<br>Key opening of switch min. radius |                            | Top Entry<br>Key opening of switch min. radius |                            |
|---|--|----------------------------|--|----------------------------|
|   | Side view #1                                     | Top View #2                | Side View #3                                   | Front View #4              |
| <b>GKZ51M, Straight key</b>               | 160 mm [6.3 in]                                  | 225 mm [8.9 in]            | 160 mm [6.3 in]                                | 225 mm [8.9 in]            |
| <b>GKZ52M, 90° key (right angle)</b>      | 160 mm [6.3 in]                                  | 225 mm [8.9 in]            | 160 mm [6.3 in]                                | 225 mm [8.9 in]            |
| <b>GKZ53M, Adjustable key (side-side)</b> | 160 mm [6.3 in]                                  | 32 mm [1.26 in]            | 160 mm [6.3 in]                                | 32 mm [1.26 in]            |
| <b>GKZ54M, Adjustable key (up-down)</b>   | 45 mm [1.77 in]                                  | 225 mm [8.9 in]            | 45 mm [1.77 in]                                | 225 mm [8.9 in]            |
| <b>GKZ55M, Multi-directional key</b>      | 18° max.<br>all directions                       | 18° max.<br>all directions | 18° max.<br>all directions                     | 18° max.<br>all directions |

# Key-Actuated Safety Switches, GKE Series

Figure 4. Key Dimensions, continued



## ADDITIONAL MATERIALS

The following associated literature is available on the Honeywell web site at [sensing.honeywell.com](http://sensing.honeywell.com):

- Product installation instructions
- Product range guide

### **WARNING** **IMPROPER INSTALLATION**

- Consult with local safety agencies and their requirements when designing a machine-control link, interface and all control elements that affect safety.
- Strictly adhere to all installation instructions.

**Failure to comply with these instructions could result in death or serious injury.**

### **WARNING** **MISUSE OF DOCUMENTATION**

- The information presented in this product sheet is for reference only. Do not use this document as a product installation guide.
- Complete installation, operation, and maintenance information is provided in the instructions supplied with each product.

**Failure to comply with these instructions could result in death or serious injury.**

### **Warranty/Remedy**

Honeywell warrants goods of its manufacture as being free of defective materials and faulty workmanship during the applicable warranty period. Honeywell's standard product warranty applies unless agreed to otherwise by Honeywell in writing; please refer to your order acknowledgment or consult your local sales office for specific warranty details. If warranted goods are returned to Honeywell during the period of coverage, Honeywell will repair or replace, at its option, without charge those items that Honeywell, in its sole discretion, finds defective. **The foregoing is buyer's sole remedy and is in lieu of all other warranties, expressed or implied, including those of merchantability and fitness for a particular purpose. In no event shall Honeywell be liable for consequential, special, or indirect damages.**

While Honeywell may provide application assistance personally, through our literature and the Honeywell web site, it is buyer's sole responsibility to determine the suitability of the product in the application.

Specifications may change without notice. The information we supply is believed to be accurate and reliable as of this writing. However, Honeywell assumes no responsibility for its use.

### **For more information**

Honeywell Sensing and Internet of Things services its customers through a worldwide network of sales offices and distributors. For application assistance, current specifications, pricing or the nearest Authorized Distributor, visit [sensing.honeywell.com](http://sensing.honeywell.com) or call:

|              |                     |
|--------------|---------------------|
| Asia Pacific | +65 6355-2828       |
| Europe       | +44 (0) 1698 481481 |
| USA/Canada   | +1-800-537-6945     |

### **Honeywell Sensing and Internet of Things**

9680 Old Bailes Road  
Fort Mill, SC 29707  
[honeywell.com](http://honeywell.com)



Компания «ЭлектроПласт» предлагает заключение долгосрочных отношений при поставках импортных электронных компонентов на взаимовыгодных условиях!

Наши преимущества:

- Оперативные поставки широкого спектра электронных компонентов отечественного и импортного производства напрямую от производителей и с крупнейших мировых складов;
- Поставка более 17-ти миллионов наименований электронных компонентов;
- Поставка сложных, дефицитных, либо снятых с производства позиций;
- Оперативные сроки поставки под заказ (от 5 рабочих дней);
- Экспресс доставка в любую точку России;
- Техническая поддержка проекта, помощь в подборе аналогов, поставка прототипов;
- Система менеджмента качества сертифицирована по Международному стандарту ISO 9001;
- Лицензия ФСБ на осуществление работ с использованием сведений, составляющих государственную тайну;
- Поставка специализированных компонентов (Xilinx, Altera, Analog Devices, Intersil, Interpoint, Microsemi, Aeroflex, Peregrine, Syfer, Eurofarad, Texas Instrument, Miteq, Cobham, E2V, MA-COM, Hittite, Mini-Circuits, General Dynamics и др.);

Помимо этого, одним из направлений компании «ЭлектроПласт» является направление «Источники питания». Мы предлагаем Вам помощь Конструкторского отдела:

- Подбор оптимального решения, техническое обоснование при выборе компонента;
- Подбор аналогов;
- Консультации по применению компонента;
- Поставка образцов и прототипов;
- Техническая поддержка проекта;
- Защита от снятия компонента с производства.



#### Как с нами связаться

**Телефон:** 8 (812) 309 58 32 (многоканальный)

**Факс:** 8 (812) 320-02-42

**Электронная почта:** [org@eplast1.ru](mailto:org@eplast1.ru)

**Адрес:** 198099, г. Санкт-Петербург, ул. Калинина, дом 2, корпус 4, литера А.