

# Amphenol

Amphenol-Tuchel Electronics GmbH

**Serie heavy|mate - C 146**

Schwere Steckverbinder

**Series heavy|mate - C 146**

Heavy duty connectors



### Das Unternehmen

Amphenol-Tuchel Electronics GmbH ist ein Unternehmen der US-amerikanischen Amphenol Corporation. Unsere eigenständige globale Präsenz im Hinblick auf Entwicklung, Produktion und Vertrieb ermöglicht es uns, für unsere Kunden außergewöhnliche technische Lösungen und einen optimalen Service zu bieten. Amphenol-Tuchel Electronics GmbH ist seit Jahren ein erfolgreicher Partner seiner Kunden und setzt Maßstäbe in der Verbindungstechnik.

### The Company

*Amphenol-Tuchel Electronics GmbH is a member of the USA based Amphenol Corporation. With our own global presence we offer our customers exceptional technical support and service in the areas of development, production and distribution. Amphenol-Tuchel Electronics GmbH has a successful history as a partner to our customers and sets standards for connector technology.*



### Allgemeine Hinweise

Diese Steckverbinder sind in Übereinstimmung mit der Niederspannungsrichtlinie (73/23/EWG) und des Gerätesicherheitsgesetzes entwickelt und gefertigt und entsprechen im besonderen den Normen DIN EN 61984 (VDE 0627); IEC 60664-1 (VDE 0110-1) und IEC 60529.

Die Steckverbinder dürfen nur entsprechend den angegebenen Bemessungsgrößen eingesetzt werden.

Die angegebenen Bemaßungen bei den Montageausschnitten stellen Anhaltswerte dar und sind im konkreten Anwendungsfall auf die Produkte abzustimmen.

Die Überprüfung, ob in speziellen, von uns nicht vorgesehenen Anwendungsbereichen die in diesem Katalog gezeigten Bauelemente anderen als den angegebenen Vorschriften entsprechen, obliegt dem Anwender. Konstruktionsänderungen aufgrund von Qualitätsverbesserungen, Weiterentwicklungen oder Fertigungsforderungen behalten wir uns vor. Mit den Angaben im Katalog werden die Bauelemente spezifiziert, nicht Eigenschaften zugesichert. Weiterverwertung dieser Katalogunterlagen in jeder Form ist nur mit unserer schriftlichen Genehmigung gestattet (URHG, UWG, BGB).

### General information







*These connectors are designed and produced in conformity with the low voltage directive (73/23/EWG) respectively Gerätesicherheitsgesetz (German law) and are especially in accordance with the standards DIN EN 61984 (VDE0627); IEC 60664-1 (VDE 0110-1) and IEC 60529.*

*The connectors may be used only within the technical ratings.*

*The indicated dimensions with the panel cut-outs represent reference values and are in the concrete application with products to be co-ordinated.*

*It is the users responsibility to check whether the components illustrated in this catalogue comply with different regulations from those stated in special fields of application which we are unable to foresee. We reserve the right to modify designs in order to improve quality, keep pace with technological advancement or meet particular requirements in production. This catalogue must not be used in any form or manner without our prior approval in writing (Copyright Law, Fair Trading Law, Civil Code).*



<b>Inhaltsverzeichnis</b>		<b>Content</b>	<b>Seite/Page</b>	
<b>Bestellnummernsystem / Part No. system</b>			<b>4</b>	
<b>Serie C 146 D</b>		<ul style="list-style-type: none"> <li>• Bemessungsspannung 250 V</li> <li>• Bemessungsstrom 10 A ... 16 A</li> <li>• Anschlussart: crimpen</li> <li>• Kontaktdurchmesser 1,6 mm</li> <li>• Nach DIN EN 175 301 801 (DIN 43652)</li> <li>• Polzahl: 7, 15, 25, 40, 50, 64, 128</li> </ul>	<ul style="list-style-type: none"> <li>• <i>Rated voltage 250 V</i></li> <li>• <i>Rated current 10 A ... 16 A</i></li> <li>• <i>Termination: crimp</i></li> <li>• <i>Contact diameter 1,6 mm</i></li> <li>• <i>According to DIN EN 175 301 801 (DIN 43652)</i></li> <li>• <i>Number of contacts: 7, 15, 25, 40, 50, 64, 128</i></li> </ul>	<b>5</b>
<b>Serie C 146 DD</b>		• Polzahl: 24, 42, 72, 108, 216	• <i>Number of contacts: 24, 42, 72, 108, 216</i>	<b>25</b>
<b>Serie C 146 E</b>		<ul style="list-style-type: none"> <li>• Bemessungsspannung 400 V</li> <li>• Bemessungsstrom 16 A ... 22 A</li> <li>• Anschlussart: vorwiegend schrauben, crimpen</li> <li>• Kontaktdurchmesser 2,5 mm</li> <li>• Polzahl: 6, 10, 16, 24, 48</li> </ul>	<ul style="list-style-type: none"> <li>• <i>Rated voltage 400 V</i></li> <li>• <i>Rated current 16 A ... 22 A</i></li> <li>• <i>Termination: mainly screw, crimp</i></li> <li>• <i>Contact diameter 2,5 mm</i></li> <li>• <i>Number of contacts: 6, 10, 16, 24, 48</i></li> </ul>	<b>29</b>
<b>Serie C 146 EE</b>		• Polzahl: 10, 18, 32, 46	• <i>Number of contacts: 10, 18, 32, 4</i>	<b>45</b>
<b>Serie C 146 E/FE/KO</b>		Steckverbinder mit Eisenkonstantan Kontakten	<i>Connectors with iron-constantan contacts</i>	<b>49</b>
<b>Serie C 146 M</b>		<ul style="list-style-type: none"> <li>• Modular aufgebauter Steckverbinder</li> <li>• Bemessungsspannung 63 - 1000 V</li> <li>• Bemessungsstrom 5 A ... 70 A</li> <li>• Anschlussart: crimpen</li> <li>• Polzahl: 3 - 280</li> </ul>	<ul style="list-style-type: none"> <li>• <i>Modular connector</i></li> <li>• <i>Rated voltage 63 - 1000 V</i></li> <li>• <i>Rated current 5 A ... 70 A</i></li> <li>• <i>Termination: crimp</i></li> <li>• <i>Number of contacts: 3 - 280</i></li> </ul>	<b>53</b>
<b>Serie C 146 A</b>		<ul style="list-style-type: none"> <li>• Schmale Bauform</li> <li>• Bemessungsspannung 250 / 400 V</li> <li>• Bemessungsstrom 14 A ... 18 A</li> <li>• Anschlussart: schrauben</li> <li>• Polzahl: 3, 4, 10, 16, 32</li> </ul>	<ul style="list-style-type: none"> <li>• <i>Narrow style</i></li> <li>• <i>Rated voltage 250 / 400 V</i></li> <li>• <i>Rated current 14 A ... 18 A</i></li> <li>• <i>Termination: screw</i></li> <li>• <i>Number of contacts: 3, 4, 10, 16, 32</i></li> </ul>	<b>81</b>
<b>Serie C 146 HSE</b>		<ul style="list-style-type: none"> <li>• Bemessungsspannung 400 V</li> <li>• Bemessungsstrom 42 A</li> <li>• Anschlussart: schrauben</li> <li>• Anschlussquerschnitt 6 mm<sup>2</sup></li> <li>• Polzahl: 6</li> </ul>	<ul style="list-style-type: none"> <li>• <i>Rated voltage 400 V</i></li> <li>• <i>Rated current 42 A</i></li> <li>• <i>Termination: screw</i></li> <li>• <i>Max. wire gauge 6 mm<sup>2</sup></i></li> <li>• <i>Number of contacts: 6</i></li> </ul>	<b>89</b>
<b>Serie C 146 HvE</b>		<ul style="list-style-type: none"> <li>• Bemessungsspannung 660 V</li> <li>• Bemessungsstrom 16 A ... 22 A</li> <li>• Anschlussart: schrauben</li> <li>• 2 nacheilende Schaltkontakte</li> <li>• Polzahl: 3, 6, 10, 16, 20, 26, 32</li> </ul>	<ul style="list-style-type: none"> <li>• <i>Rated voltage 660 V</i></li> <li>• <i>Rated current 16 A ... 22 A</i></li> <li>• <i>Termination: screw</i></li> <li>• <i>2 delayed mating contacts</i></li> <li>• <i>Number of contacts: 3, 6, 10, 16, 20, 26, 32</i></li> </ul>	<b>93</b>
<b>Serie C 146 S</b>		<ul style="list-style-type: none"> <li>• Bemessungsspannung 125 - 600 V</li> <li>• Bemessungsstrom 10 A ... 70 A</li> <li>• Anschlussart: crimpen, schrauben, löten</li> <li>• Polzahl: 4, 57</li> </ul>	<ul style="list-style-type: none"> <li>• <i>Rated voltage 125 - 600 V</i></li> <li>• <i>Rated current 10 A ... 70 A</i></li> <li>• <i>Termination: crimp, screw, solder</i></li> <li>• <i>Number of contacts: 4, 57</i></li> </ul>	<b>101</b>
<b>Gehäuse / Housings</b>			<b>107</b>	
<b>EMV Gehäuse / EMC housings</b>			<b>157</b>	
<b>Zubehör / Accessories</b>			<b>169</b>	
<b>Weitere Informationen/ Additional information</b>				
Maßzeichnungen Kontakte / <i>Drawings of contacts</i>			177	
Sicherheitseinteilung / <i>Safety classification</i>			181	
Allgemeine Technische Informationen / <i>General technical information</i>			182	
Bestellnummernverzeichnis / <i>Summary of Part Numbers</i>			202	

**Kontakteinsätze, Gehäuse / Contact inserts, housing**

	<b>C146</b> 1)	<b>10A</b> 2)	<b>007</b> 3)	<b>000</b> 4)	<b>2</b> 5)	<b>C</b> 6)
1)	Serie Series					
2)	Type Type				A = Stifteinsatz / male insert B = Buchseneinsatz / female insert F = Gehäuseunterteil, PG / housing, PG N = Gehäuseunterteil, metrisch / housing, metric G = Gehäuseoberteil, PG / hood, PG R = Gehäuseoberteil, metrisch / hood, metric Z = Schutzdeckel / cover	
3)	Polzahl Number of contacts				z. B. 007 = 7 pol e. g. 007 = 7 contacts	
4)	Ausführungsvariante Design version					
5)	Serie Series				1 = E Serie / E series + FE / KO Serie / FE / KO series 2 = D Serie / D series 3 = HVE Serie / HVE series 4 = A Serie / A series 5 = HSE Serie / HSE series 6 = S Serie / S series 8 = M Serie / M series 9 = DD Serie / DD series 10 = EE Serie / EE series	
6)	Verpackungseinheit Packing unit				X = 10 C = 100 M = 1000	



**Kontakte / Contacts**



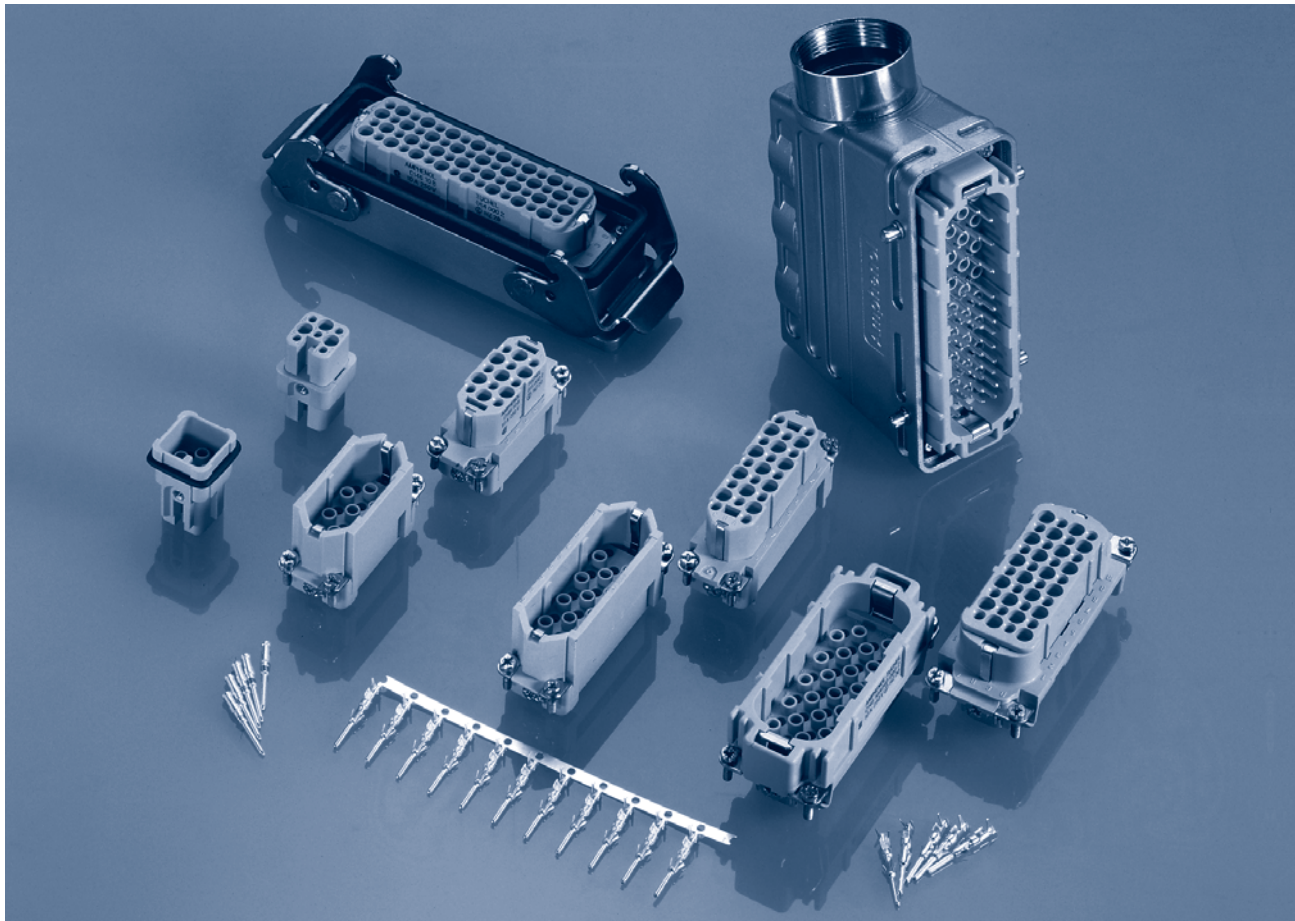

	<b>V</b> 1)	<b>N 01</b> 2)	<b>016</b> 3)	<b>0002</b> 4)	<b>(1)</b> 5)
1)	Lieferausführung: Supplied as:				V = Einzelkontakt 100 Stück Single pack 100 pcs.  Z = Bandkontakt mit 100, 200 oder 500 Kontakten Contacts on reel 100, 200 or 500 contacts  H = Bandkontakte mit 2000 Kontakten für Crimpmaschinen (Kontaktzuführung rechts) Contacts on reel with 2000 contacts for crimping machines (contact feeding right hand side)  T = Bandkontakte mit 2000 Kontakten für Crimpmaschinen (Kontaktzuführung links) Contacts on reel with 2000 contacts for crimping machines (contact feeding left hand side)
2)	Kontaktart: Type of contact:				N 01 = Kontaktstift / male contact N 02 = Kontaktbuchse / female contact
3)	Kontaktgröße Contact size				z. B. 016 = 1,6 mm e. g. 016 = 1,6 mm
4)	Ausführungsvariante Design version				
5)	Oberfläche: Plating:				(1) = versilbert / silver plated (2) = vergoldet (auf Anfrage) / gold plated (upon request)



# C 146 D

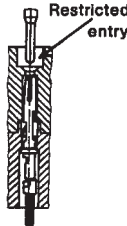

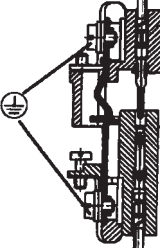



Hauptmerkmale		Main characteristics	
<ul style="list-style-type: none"> <li>• Bemessungsspannung 250 V</li> <li>• Bemessungsstrom 10 A ... 16 A</li> <li>• Anschlussart: crimpen</li> <li>• Kontaktdurchmesser 1,6 mm</li> <li>• nach DIN EN 175 301-801 (DIN 43652)</li> <li>• Polzahl: 7, 15, 25, 40, 50, 64, 128</li> </ul>		<ul style="list-style-type: none"> <li>• Rated voltage 250 V</li> <li>• Rated current 10 A ... 16 A</li> <li>• Termination: crimp</li> <li>• Contact diameter 1,6 mm</li> <li>• According to DIN EN 175 301-801 (DIN 43652)</li> <li>• Number of contacts: 7, 15, 25, 40, 50, 64, 128</li> </ul>	
Zulassungen / Approvals Prüfstelle / Testhouse		Kennwerte / Characteristics	Zulassungs-Nummer / Approval-No.
SEV		250 V, 10 A	
UL		600 V, 10 A 600 V, 15 A (Hochstrom / High current)	E 63093
CSA		600 V, 10 A	48932
<p>Zulassungen beziehen sich im allgemeinen auf repräsentative Ausführungen der Steckverbinderserie. Prüfumfang und Prüfvorschrift auf Anfrage.</p>		<p><i>In general approvals refer to representative versions of the connector series. Extent and specification of tests upon request.</i></p>	

<p>Allgemeine Hinweise</p>  <p>General information</p>	<ul style="list-style-type: none"> <li>• Kontakteinsätze ohne Crimpkontakte, Crimpwerkzeuge siehe separater Katalog „Werkzeuge“.</li> <li>• Kontakte müssen separat bestellt werden, Verarbeitungs- und Montagehinweise siehe Katalog „Werkzeuge“.</li> <li>• Für die Einsätze der Serie C 146 D werden die hohen Gehäusebauformen empfohlen.</li> <li>• Steckverbinder der Serie C 146 D dürfen unter Spannung, jedoch nicht unter Strom betätigt werden. Werden die Steckverbinder unter Last gesteckt und getrennt, ist der Strom auf 15 % des Bemessungsstroms zu begrenzen.</li> <li>• Für Kontakteinsätze für gedrehte Kontakte werden Führungsstifte und Führungsbuchsen empfohlen (siehe Seite 174).</li> <li>• Bei Verwendung der Kontakteinsätze mit zwei PE-Anschlüssen ohne Gehäuse ist darauf zu achten, dass jeweils die gegenüberliegenden PE-Anschlüsse miteinander verbunden werden.</li> </ul> <p><i>• Contact inserts without crimp contacts, crimping tools see separate catalogue „Tools“.</i></p> <p><i>• Contacts must be ordered separately, processing instructions see catalogue „Tools“.</i></p> <p><i>• We recommend using the high profile housings / hoods for the C146 D inserts.</i></p> <p><i>• Connectors series C146 D may be engaged or disengaged when live but without electrical load.</i></p> <p><i>If these connectors are mated or unmated under load, the load shall be reduced to 15 % of the rated current.</i></p> <p><i>• For contact inserts for turned contacts, guide pins and guide socket are recommended (see page 174).</i></p> <p><i>• By using contact inserts with two PE-connections without hoods, it is necessary to connect the facing of each PE-connection.</i></p>
<p>Genormte Steckverbinder nach DIN EN 175 301 - 801 (DIN 43652)</p> <p>Standardised connectors according to DIN EN 175 301 - 801 (DIN 43652)</p>	<p>Steck- und austauschbar mit allen Fremdfabrikaten nach Norm.</p> <p>a) Kontakteinsatz/Kontakteinsatz 15, 25, 40, 64 pol. b) Kontakteinsatz/Gehäuse 15, 25, 40, 64 pol.</p> <p><i>Interchangeable with all other products which are according to the standard.</i></p> <p><i>a) Contact insert to contact insert 15, 25, 40, 64 way.</i></p> <p><i>b) Contact insert to housing 15, 25, 40, 64 way.</i></p>
<p>Hoher Schutz vor Fehlsteckungen</p> <p>High protection against mismatching</p>	<p>Buchsenkontakteinsatz mit trichterförmiger, verengter Stecköffnung. Hohe Steck- und Kontaktsicherheit mit gestanzten Kontakten.</p> <p><i>Female inserts with funnel shaped contact entry avoids mismatching with stamped contacts.</i></p> 
<p>Kontakteinsätze für gestanzte Kontakte und für gedrehte Kontakte</p> <p>Contact inserts for stamped contacts and for turned contacts</p>	
<p>Voreilender Schutzkontakt</p> <p>First-to-mate last-to-break protective ground contact</p>	<p>Bei Verwendung von Schutzleitern mit Querschnitten <math>&lt;1\text{mm}^2</math> ist ein geeigneter Kabelschuh zu verwenden.</p> <p><i>When used PE wire with a cross section <math>&lt;1\text{mm}^2</math>, a cable lug should be used.</i></p> 
<p>Große Gehäuseauswahl in 2 Bauhöhen (ab Seite 107)</p> <p>Large range of housings in 2 different heights (see page 107)</p>	

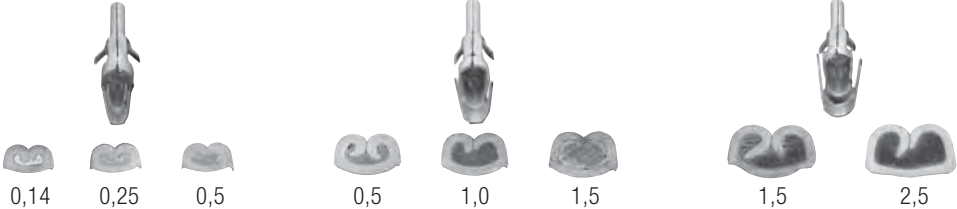
**Crimp Technik**  
*Crimp technology*

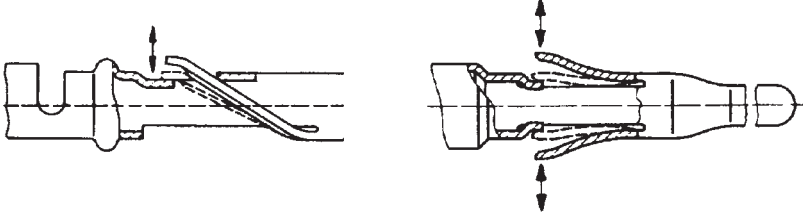
**Hauptmerkmale der gestanzten Crimpkontakte**  
*Main characteristics of the stamped crimp contacts*

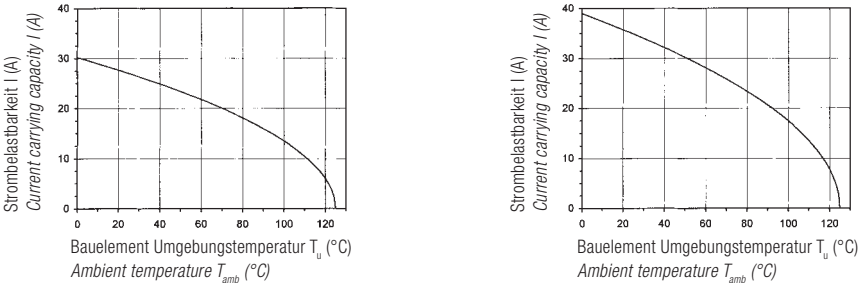
<p>Großer Crimpbereich <i>Large range of wire gauges</i></p> <p>Gasdichte Verbindung (Kaltverschweißung) <i>Gas-tight (coldwelding)</i></p>	<p>.N01 016 0003 (1) <sup>1)</sup>      .N01 016 0002 (1) <sup>1)</sup>      .N01 016 0005 (1) <sup>1)</sup></p>  <p>0,14   0,25   0,5      0,5   1,0   1,5      1,5   2,5</p>
<p>Gestanzte Crimpkontakte mit Isolierungshalterung um mechanische Beanspruchung von der Crimpverbindung fernzuhalten <i>Stamped crimp contacts with insulation crimp, to absorb mechanical stress from the crimped connection</i></p>	 <p>Isolierungshalterung <i>Insulation grip</i></p>
<p>Mechanischer Rasthakenanschlag bei Buchsen- und Stiftkontakt <i>Mechanical retention spring stop on female and male contact</i></p> <p>Einfache Montage <i>Easy assembly</i></p>	<p>Buchsenkontakt <i>Female contact</i></p> <p>Stiftkontakt <i>Male contact</i></p> 
<p>Kostengünstige, einfache Verarbeitung Werkzeuge siehe Katalog „Werkzeuge“ <i>Economical and easy processing Tools see catalogue „Tools“</i></p>	 <p>Service-Anwendungen <i>Service application</i></p> <p>Einzel-Fertigung <i>Single production</i></p> <p>Kleinserie <i>Small series</i></p> <p>Serie <i>Series</i></p>
<p>Hohe Strombelastbarkeit (siehe Derating Kurven) <i>High current carrying capacity (see derating curves)</i></p>	<p>Beispiel Einzelkontakt / <i>Example single contact</i></p>  <p>Standardkontakt, Anschlussquerschnitt 2,5 mm<sup>2</sup> <i>Standard contact, wire gauge 2.5 mm<sup>2</sup></i></p> <p>Hochstromkontakt, Anschlussquerschnitt 2,5 mm<sup>2</sup> <i>High current contact, wire gauge 2.5 mm<sup>2</sup></i></p>

<sup>1)</sup> Erläuterung der Bestell-Nr. für die Kontakte siehe Seite 4

<sup>1)</sup> Explanation of the Part No. for contacts see page 4



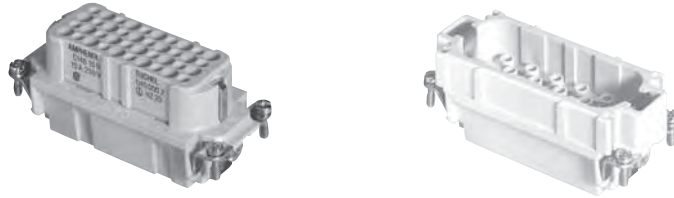

**Kontakteinsätze / Connector inserts**

<b>Allgemeine Kennwerte</b>	<b>General Characteristics</b>	<b>Norm / Standard</b>	<b>Wert / Value</b>							
Polzahl	Number of contacts		7+PE/8	15	25	40	50 2 x 25	64	128 2 x 64	
Kontaktanordnung	Contact arrangement	DIN EN 175 301-801 (DIN 43652)		•	•	•		•		
Anschlusstechnik	Termination technique		crimpen / crimp, wire wrap							
Max. Leiterdurchmesser	Max. wire diameter		4,1 mm							
Brennbarkeit	Flammbarkeit	UL 94	V-0							
<b>Elektrische Kennwerte</b>	<b>Electrical Characteristics</b>									
Bemessungsspannung <sup>3)</sup>	Rated voltage	IEC 60664-1	250 V~ (400 V~ <sup>1)</sup> ) (600 V UL / CSA <sup>5)</sup> )							
Verschmutzungsgrad	Pollution degree	IEC 60664-1	3							
Überspannungskategorie	Installation (overvoltage) category	IEC 60664-1	III							
Isolierstoffgruppe	Material group	IEC 60664-1	III b							
Bemessungs-Stoßspannung	Rated impulse withstand voltage	IEC 60664-1	4 kV							
Spannungsfestigkeit	Voltage proof	IEC 60512-2; Test 4 a	2,2 kV							
Strombelastbarkeit	Rated current	IEC 60512-3; Test 5 b	siehe Derating Kurven / see derating curves							
Bemessungsstrom T <sub>u</sub> = 40 °C	Rated current T <sub>amb</sub> = 40 °C		16 A	12 A	12 A	10 A	10 A	10 A	10 A	
Isolationswiderstand	Insulation resistance	IEC 60512-2; Test 3 a	≥ 10 <sup>12</sup> Ω <sup>4)</sup>							
Luftstrecke	Clearance	IEC 60664-1	> 3,5 mm							
Kriechstrecke	Creepage	IEC 60664-1	> 4,6 mm							
<b>Klimatische Kennwerte</b>	<b>Climatical Characteristics</b>									
Prüfklasse	Climatic category	IEC 60068-1	40 / 125 / 21							
Obere Grenztemperatur	Upper temperature	IEC 60512-6; Test 11 i	+ 125 °C / 1000 h							
Untere Grenztemperatur	Lower temperature	IEC 60512-6; Test 11 i	- 40 °C							
<b>Mechanische Kennwerte</b>	<b>Mechanical Characteristics</b>									
Steck- und Ziehkraft	Insertion and withdrawal forces	IEC 60512-7; Test 13 b	10-15 N	20-30 N	40-60 N	60-90 N	80-120 N	100-150 N	200-300 N	
IP-Schutzart Stifteinsatz	IP-degree of protection pin insert	IEC 60529	ungesteckt/unmated IP00				gesteckt/mated IP20			
IP-Schutzart Buchseneinsatz	IP-degree of protection socket insert	IEC 60529	ungesteckt/unmated IP20				gesteckt/mated IP20			
Gewicht Stifteinsatz	Weight pin insert		8 g	28 g	34 g	53 g	68 g	65 g	130 g	
Gewicht Buchseneinsatz	Weight socket insert		8 g	30 g	38 g	64 g	76 g	82 g	164 g	
Mechanische Lebensdauer	Mechanical operation	IEC 60512-5; Test 9 a	≥ 500 Steckzyklen / mating cycles							
<b>Werkstoffe</b>	<b>Materials</b>									
Kontakteinsatz	Insert		PBTP	PC GV <sup>2)</sup>						
Farbe	Colour		grau / grey							

<sup>1)</sup> bei modifizierter Kontaktanordnung, siehe Seite 24 / modified contact arrangement, see page 24

<sup>2)</sup> Polycarbonat-glasfaserverstärkt / polycarbonat-glas fibre filled

<sup>3)</sup> Einschränkung für 8 pol mit Metallgehäuse siehe Seite 10 / Restriction for 8 contacts in metal housing see page 10

<sup>4)</sup> bei Beanspruchung > 10 <sup>10</sup> Ω / Under operating condition > 10 <sup>10</sup> Ω

<sup>5)</sup> Hinweisschild für CSA-Anwendung siehe Seite 176 / Label for CSA application see page 176

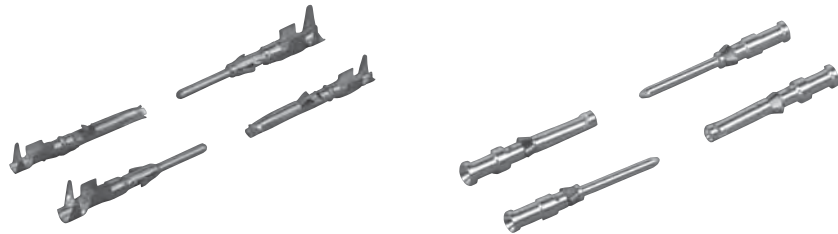
**Gestanzte Crimpkontakte / Stamped crimp contacts**

<b>Elektrische Kennwerte</b>	<b>Electrical Characteristics</b>		
Durchgangswiderstand	Contact resistance	IEC 60512-2; Test 2 a	≤ 5 m Ω
Kapazität Kontakt-Kontakt	Capacity contact-contact	IEC 60512-9; Test 22 a	≥ 2 p F
Kapazität Kontakt-Gehäuse	Capacity contact-housing	IEC 60512-9; Test 22 a	≥ 3,2 p F
<b>Klimatische Kennwerte</b>	<b>Climatical Characteristics</b>		
Obere Grenztemperatur	Upper temperature	IEC 60512-6; Test 11 i	+ 125 °C
Untere Grenztemperatur	Lower temperature	IEC 60512-6; Test 11 i	- 40 °C
<b>Mechanische Kennwerte</b>	<b>Mechanical Characteristics</b>		
Mechanische Lebensdauer	Mechanical operation	IEC 60512-5; Test 9 a	≥ 500 Steckzyklen / mating cycles
<b>Werkstoffe</b>	<b>Materials</b>		
Stiftkontakt	Male contact		Cu Zn (Messing / brass)
Buchsenkontakt	Female contact		Cu Sn (Zinnbronze / Tin bronze)
Kontaktoberfläche	Contact plating		Ag (silber / silver)

**Gedrehte Crimpkontakte / Turned crimp contacts**

<b>Elektrische Kennwerte</b>	<b>Electrical Characteristics</b>		
Durchgangswiderstand	Contact resistance	IEC 60512-2	≤ 5 m Ω
<b>Klimatische Kennwerte</b>	<b>Climatical Characteristics</b>		
Obere Grenztemperatur	Upper temperature	IEC 60512-6	+ 100 °C
Untere Grenztemperatur	Lower temperature	IEC 60512-6	- 40 °C
<b>Mechanische Kennwerte</b>	<b>Mechanical Characteristics</b>		
Mechanische Lebensdauer	Mechanical operation	IEC 60512-5; Test 9 a	≥ 500 Steckzyklen / mating cycles
<b>Werkstoffe</b>	<b>Materials</b>		
Stiftkontakt	Male contact		Cu Zn (Messing / brass)
Buchsenkontakt	Female contact		Cu Zn (Messing / brass)
Kontaktoberfläche	Contact plating		Ag (silber / silver)







**C 146 D**  
**7 + ⊕, 8**

**Steckverbinder**  
**Connectors**

**250 V~** in Kunststoffgehäuse  
*in thermoplastic housings*

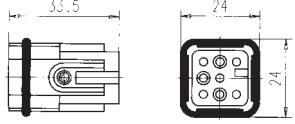
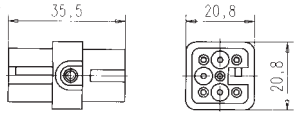
**42 V~** in Metallgehäuse  
*in metal housings*

**Gehäuse siehe Seite 110-113**  
**Housings see page 110-113**

Bezeichnung - Abbildung Description - Figure	Maßzeichnung Drawing	Bestell Nr. / Part No.	
		Stifteinsatz / Male insert	Buchseneinsatz / Female insert
Kontakteinsatz / Contact insert 7 + ⊕     250 V ~ <b>nur für Kunststoffgehäuse</b> <b>only for thermoplastic housings</b>	Stifteinsatz Male insert 	<b>C146 10A007 000 2<sup>1)</sup></b> (für gestanzte Crimpkontakte) (for stamped crimp contacts)	<b>C146 10B007 000 2<sup>1)</sup></b> (für gestanzte Crimpkontakte) (for stamped crimp contacts)
	Buchseneinsatz Female insert 	<b>C146 10A007 500 2</b> (für gedrehte Crimpkontakte) (for turned crimp contacts)	<b>C146 10B007 500 2</b> (für gedrehte Crimpkontakte) (for turned crimp contacts)
Kontakteinsatz / Contact insert 8 pol     42 V ~	Stifteinsatz Male insert 	<b>C146 10A008 000 2</b> (für gestanzte Crimpkontakte) (for stamped crimp contacts)	<b>C146 10B008 000 2</b> (für gestanzte Crimpkontakte) (for stamped crimp contacts)
	Buchseneinsatz Female insert 	<b>C146 10A008 500 2</b> (für gedrehte Crimpkontakte) (for turned crimp contacts)	<b>C146 10B008 500 2</b> (für gedrehte Crimpkontakte) (for turned crimp contacts)

**Kontaktanordnung / Contact arrangement**

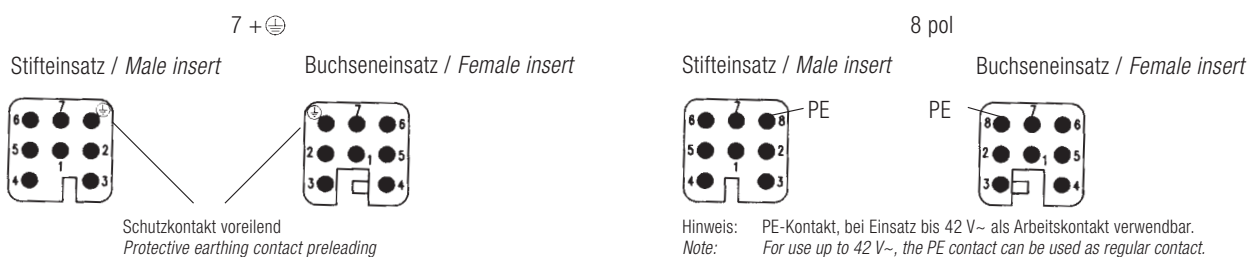

<sup>1)</sup> auch erhältlich als Großpackung, 100 Stück ... 000 2, „C“ / also available for big volume, 100 pcs. ... 000 2, „C“



C 146 D

7 +  ,8

**Crimpkontakte**  
*Crimp contacts*

Gestanzte Einzelkontakte  
*Stamped single contacts*



Gedrehte Einzelkontakte  
*Turned single contacts*



Gestanzte Bandkontakte für Crimpzangen  
*Stamped contacts on reel for hand crimping tools*



200 / 100 Stück  
200 / 100 pcs

Gestanzte Bandkontakte für Crimpmaschinen  
*Stamped contacts on reel for crimp machines*



2000 Stück  
(Zuführung links oder rechts)  
2000 pcs  
(feeding left or right hand side)

D

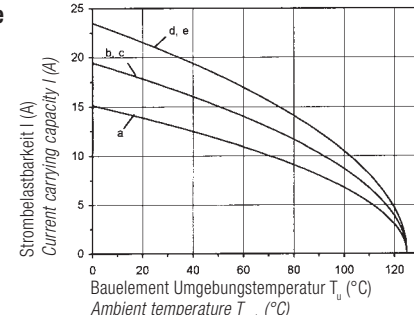
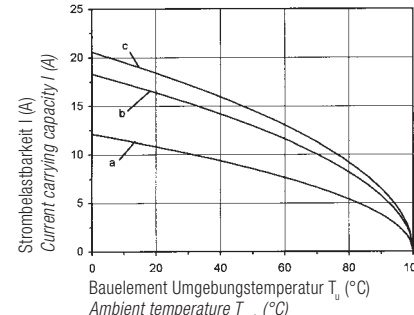
Lieferform <i>Supplied as</i>	für Leiter- querschnitt <i>for wire gauge</i>	AWG	Stück- zahl <i>Pieces</i>	Bestell Nr. <sup>1)</sup> Stiftkontakt <i>Male contact</i>	Part No. <sup>1)</sup> Buchsenkontakt <i>Female contact</i>	Bestell Nr. <sup>1)</sup> Stiftkontakt <i>Male contact</i>	Part No. <sup>1)</sup> Buchsenkontakt <i>Female contact</i>
Gestanzte Einzelkontakte / <i>Stamped single contacts</i>				versilbert / <i>silver plating</i>		vergoldet / <i>gold plating</i>	
Standard Hochstrom <i>High current</i>	0,14 - 0,5 mm <sup>2</sup>	26 - 20	100	VN01 016 0003 (1)	VN02 016 0003 (1)	VN01 016 0003 (2)	VN02 016 0003 (2)
	0,5 - 1,5 mm <sup>2</sup>	20 - 16	100	VN01 016 0002 (1)	VN02 016 0002 (1)	VN01 016 0002 (2)	VN02 016 0002 (2)
	1,5 - 2,5 mm <sup>2</sup>	16 - 14	100	VN01 016 0005 (1)	VN02 016 0005 (1)	VN01 016 0005 (2)	VN02 016 0005 (2)
	0,5 - 1,5 mm <sup>2</sup>	20 - 16	100	VN01 016 0015 (1)	VN02 016 0015 (1)		
	1,5 - 2,5 mm <sup>2</sup>	16 - 14	100	VN01 016 0016 (1)	VN02 016 0016 (1)		
Gestanzte Bandkontakte für Crimpzangen / <i>Stamped Contacts on reel for hand crimp tools</i>							
Standard Hochstrom <i>High current</i>	0,14 - 0,5 mm <sup>2</sup>	26 - 20	200	ZN01 016 0003 (1)	ZN02 016 0003 (1)	ZN01 016 0003 (2)	ZN02 016 0003 (2)
	0,5 - 1,5 mm <sup>2</sup>	20 - 16	200	ZN01 016 0002 (1)	ZN02 016 0002 (1)	ZN01 016 0002 (2)	ZN02 016 0002 (2)
	1,5 - 2,5 mm <sup>2</sup>	16 - 14	100	ZN01 016 0005 (1)	ZN02 016 0005 (1)	ZN01 016 0005 (2)	ZN02 016 0005 (2)
	0,5 - 1,5 mm <sup>2</sup>	20 - 16	200	ZN01 016 0015 (1)	ZN02 016 0015 (1)		
	1,5 - 2,5 mm <sup>2</sup>	16 - 14	100	ZN01 016 0016 (1)	ZN02 016 0016 (1)		
Gestanzte Bandkontakte für Crimpmaschinen / <i>Stamped contacts on reel for crimp machines</i>							
Kontaktzuführung rechts <i>Contact feeding right hand side</i>	0,14 - 0,5 mm <sup>2</sup>	26 - 20	2000	HN01 016 0003 (1)	HN02 016 0003 (1)	HN01 016 0003 (2)	HN02 016 0003 (2)
	0,5 - 1,5 mm <sup>2</sup>	20 - 16	2000	HN01 016 0002 (1)	HN02 016 0002 (1)	HN01 016 0002 (2)	HN02 016 0002 (2)
	Standard 1,5 - 2,5 mm <sup>2</sup>	16 - 14	2000	HN01 016 0005 (1)	HN02 016 0005 (1)	HN01 016 0005 (2)	HN02 016 0005 (2)
	Hochstrom 1,5 - 2,5 mm <sup>2</sup>	20 - 16	2000	HN01 016 0015 (1)	HN02 016 0015 (1)		
	1,5 - 2,5 mm <sup>2</sup>	16 - 14	2000	HN01 016 0016 (1)	HN02 016 0016 (1)		
Kontaktzuführung links <i>Contact feeding left hand side</i>	0,14 - 0,5 mm <sup>2</sup>	26 - 20	2000	TN01 016 0003 (1)	TN02 016 0003 (1)	TN01 016 0003 (2)	TN02 016 0003 (2)
	0,5 - 1,5 mm <sup>2</sup>	20 - 16	2000	TN01 016 0002 (1)	TN02 016 0002 (1)	TN01 016 0002 (2)	TN02 016 0002 (2)
	Standard 1,5 - 2,5 mm <sup>2</sup>	16 - 14	2000	TN01 016 0005 (1)	TN02 016 0005 (1)	TN01 016 0005 (2)	TN02 016 0005 (2)
	Hochstrom 1,5 - 2,5 mm <sup>2</sup>	20 - 16	2000	TN01 016 0015 (1)	TN02 016 0015 (1)		
	1,5 - 2,5 mm <sup>2</sup>	18 - 14	2000	TN01 016 0016 (1)	TN02 016 0016 (1)		
Gedrehte Crimpkontakte / <i>Turned crimp contacts</i>							
Einzelkontakt <i>Single contact</i>	0,14 - 0,37 mm <sup>2</sup>	26 - 22	100	VN01 016 0024 (1)C	VN02 016 0024 (1)C	VN01 016 0024 (2)C	VN02 016 0024 (2)C
	0,5 mm <sup>2</sup>	20	100	VN01 016 0025 (1)C	VN02 016 0025 (1)C	VN01 016 0025 (2)C	VN02 016 0025 (2)C
	0,75 - 1,0 mm <sup>2</sup>	20 - 16	100	VN01 016 0026 (1)C	VN02 016 0026 (1)C	VN01 016 0026 (2)C	VN02 016 0026 (2)C
	1,5 mm <sup>2</sup>	16 - 15	100	VN01 016 0027 (1)C	VN02 016 0027 (1)C	VN01 016 0027 (2)C	VN02 016 0027 (2)C
	2,5 mm <sup>2</sup>	14	100	VN01 016 0028 (1)C	VN02 016 0028 (1)C	VN01 016 0028 (2)C	VN02 016 0028 (2)C
Derating Kurven / <i>Derating curves</i>							
<b>Gestanzte Kontakte</b> <i>Stamped contacts</i> 				<b>Gedrehte Kontakte</b> <i>Turned contacts</i> 			
<b>Kurve / Curve</b>	<b>Kontakt / Contact</b>	<b>Querschnitt / Wire gauge</b>		<b>Kurve / Curve</b>	<b>Kontakt / Contact</b>	<b>Querschnitt / Wire gauge</b>	
a	Standard gestanzte	0,5 mm <sup>2</sup>		a	Standard gedrehte	0,5 mm <sup>2</sup>	
b	Standard gestanzte	1,5 mm <sup>2</sup>		b	Standard gedrehte	1,5 mm <sup>2</sup>	
c		2,5 mm <sup>2</sup>		c		2,5 mm <sup>2</sup>	
d	Hochstrom gestanzte	1,5 mm <sup>2</sup>					
e	Hochstrom gestanzte	2,5 mm <sup>2</sup>					

<sup>1)</sup> Erläuterung der Bestell-Nr. für die Kontakte siehe Seite 4  
<sup>1)</sup> Explanation of the Part No. for contacts see page 4

Abisolierlängen siehe S. 198  
Stripping length see p. 198



C 146 D

15 + 

Steckverbinder  
Connectors

250 V~ 10 A/15 A DIN EN 175 301-801 (DIN 43652)

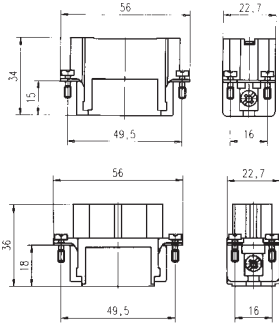
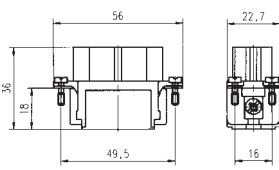
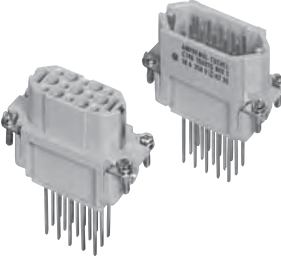
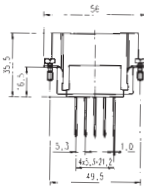
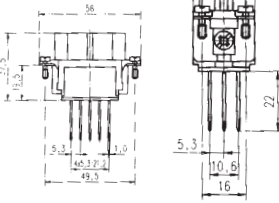
Gehäuse siehe Seite 114-117  
Housings see page 114-117

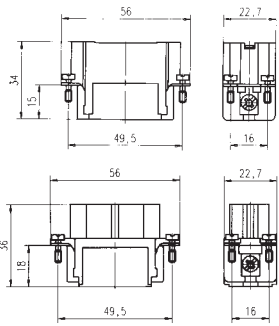
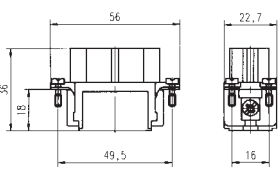
Bezeichnung - Abbildung Description - Figure	Maßzeichnung Drawing	Bestell Nr. / Part No.	
		Stifteinsatz / Male insert	Buchseinsatz / Female insert
Kontakteinsatz Contact insert  	Stifteinsatz Male insert    Buchseinsatz Female insert  	C146 10A015 000 2 (für gestanzte Crimpkontakte) (for stamped crimp contacts)  C146 10A015 500 2 (für gedrehte Crimpkontakte) (for turned crimp contacts)	C146 10B015 000 2 (für gestanzte Crimpkontakte) (for stamped crimp contacts)  C146 10B015 500 2 (für gedrehte Crimpkontakte) (for turned crimp contacts)
Wickelanschluss <sup>2)</sup> Wire wrap termination  	Stifteinsatz Male insert    Buchseinsatz Female insert  	C146 10A015 009 2	C146 10B015 009 2
Kontakteinsatz 2 X PE Anschluss <sup>1)</sup> Contact insert 2 X PE termination <sup>1)</sup>  	Stifteinsatz Male insert    Buchseinsatz Female insert  	C146 10A015 060 2 (für gestanzte Crimpkontakte) (for stamped crimp contacts)	C146 10B015 060 2 (für gestanzte Crimpkontakte) (for stamped crimp contacts)

Montageanleitung, Ansicht von Steckverbinder-Anschlussseite  
Assembly instructions, view from termination side

Stifteinsatz  
Male insert

Buchseinsatz  
Female insert

Montageausschnitt (Kontaktträger)  
Panel cut out (insert)

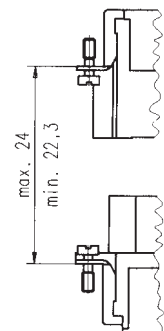
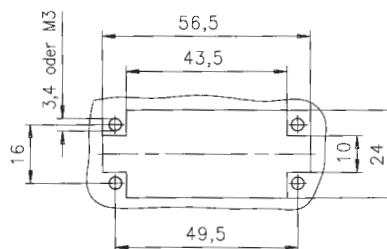
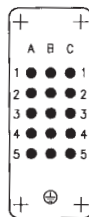
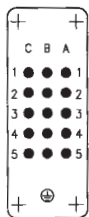

<sup>1)</sup> Beim Einbau der Steckverbinder in nicht leitende Gehäuse sind beide Schutzleiter (Ausführung 2 x PE) anzuschließen.  
If connectors are mounted in non conductive housings both protective earthing terminals shall be mounted.

<sup>2)</sup> IP-Schutzart im Anschlussbereich IP 00  
IP-degree of protection on termination side IP 00

C 146 D

15 + 

**Crimpkontakte**  
*Crimp contacts*

Gestanzte Einzelkontakte  
*Stamped single contacts*



Gedrehte Einzelkontakte  
*Turned single contacts*



Gestanzte Bandkontakte für Crimpzangen  
*Stamped contacts on reel for hand crimping tools*



200 / 100 Stück  
200 / 100 pcs

Gestanzte Bandkontakte für Crimpmaschinen  
*Stamped contacts on reel for crimp machines*



2000 Stück  
(Zuführung links  
oder rechts)  
2000 pcs  
(feeding left or  
right hand side)

D

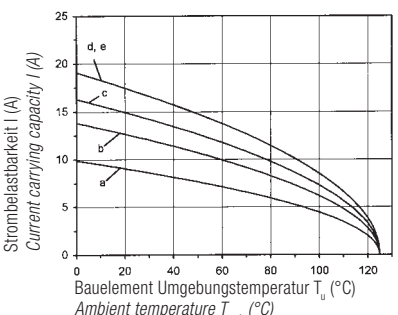
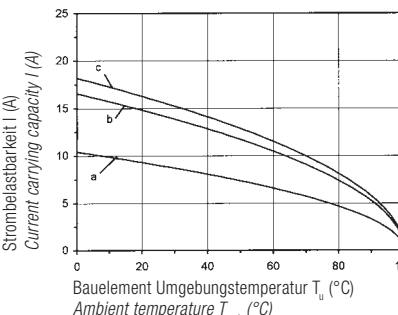
Lieferform <i>Supplied as</i>	für Leiter- querschnitt <i>for wire gauge</i>	AWG	Stück- zahl <i>Pieces</i>	Bestell Nr. <sup>1)</sup> Stiftkontakt <i>Male contact</i>	Part No. <sup>1)</sup> Buchsenkontakt <i>Female contact</i>	Bestell Nr. <sup>1)</sup> Stiftkontakt <i>Male contact</i>	Part No. <sup>1)</sup> Buchsenkontakt <i>Female contact</i>
Gestanzte Einzelkontakte / <i>Stamped single contacts</i>				versilbert / <i>silver plating</i>		vergoldet / <i>gold plating</i>	
Standard Hochstrom <i>High current</i>	0,14 - 0,5 mm <sup>2</sup>	26 - 20	100	VN01 016 0003 (1)	VN02 016 0003 (1)	VN01 016 0003 (2)	VN02 016 0003 (2)
	0,5 - 1,5 mm <sup>2</sup>	20 - 16	100	VN01 016 0002 (1)	VN02 016 0002 (1)	VN01 016 0002 (2)	VN02 016 0002 (2)
	1,5 - 2,5 mm <sup>2</sup>	16 - 14	100	VN01 016 0005 (1)	VN02 016 0005 (1)	VN01 016 0005 (2)	VN02 016 0005 (2)
	0,5 - 1,5 mm <sup>2</sup>	20 - 16	100	VN01 016 0015 (1)	VN02 016 0015 (1)		
	1,5 - 2,5 mm <sup>2</sup>	16 - 14	100	VN01 016 0016 (1)	VN02 016 0016 (1)		
Gestanzte Bandkontakte für Crimpzangen / <i>Stamped Contacts on reel for hand crimp tools</i>							
Standard Hochstrom <i>High current</i>	0,14 - 0,5 mm <sup>2</sup>	26 - 20	200	ZN01 016 0003 (1)	ZN02 016 0003 (1)	ZN01 016 0003 (2)	ZN02 016 0003 (2)
	0,5 - 1,5 mm <sup>2</sup>	20 - 16	200	ZN01 016 0002 (1)	ZN02 016 0002 (1)	ZN01 016 0002 (2)	ZN02 016 0002 (2)
	1,5 - 2,5 mm <sup>2</sup>	16 - 14	100	ZN01 016 0005 (1)	ZN02 016 0005 (1)	ZN01 016 0005 (2)	ZN02 016 0005 (2)
	0,5 - 1,5 mm <sup>2</sup>	20 - 16	200	ZN01 016 0015 (1)	ZN02 016 0015 (1)		
	1,5 - 2,5 mm <sup>2</sup>	16 - 14	100	ZN01 016 0016 (1)	ZN02 016 0016 (1)		
Gestanzte Bandkontakte für Crimpmaschinen / <i>Stamped contacts on reel for crimp machines</i>							
Kontaktzuführung rechts <i>Contact feeding right hand side</i>	0,14 - 0,5 mm <sup>2</sup>	26 - 20	2000	HN01 016 0003 (1)	HN02 016 0003 (1)	HN01 016 0003 (2)	HN02 016 0003 (2)
	0,5 - 1,5 mm <sup>2</sup>	20 - 16	2000	HN01 016 0002 (1)	HN02 016 0002 (1)	HN01 016 0002 (2)	HN02 016 0002 (2)
	Standard 1,5 - 2,5 mm <sup>2</sup>	16 - 14	2000	HN01 016 0005 (1)	HN02 016 0005 (1)	HN01 016 0005 (2)	HN02 016 0005 (2)
	Hochstrom 1,5 - 2,5 mm <sup>2</sup>	16 - 14	2000	HN01 016 0015 (1)	HN02 016 0015 (1)		
	1,5 - 2,5 mm <sup>2</sup>	16 - 14	2000	HN01 016 0016 (1)	HN02 016 0016 (1)		
Kontaktzuführung links <i>Contact feeding left hand side</i>	0,14 - 0,5 mm <sup>2</sup>	26 - 20	2000	TN01 016 0003 (1)	TN02 016 0003 (1)	TN01 016 0003 (2)	TN02 016 0003 (2)
	0,5 - 1,5 mm <sup>2</sup>	20 - 16	2000	TN01 016 0002 (1)	TN02 016 0002 (1)	TN01 016 0002 (2)	TN02 016 0002 (2)
	Standard 1,5 - 2,5 mm <sup>2</sup>	16 - 14	2000	TN01 016 0005 (1)	TN02 016 0005 (1)	TN01 016 0005 (2)	TN02 016 0005 (2)
	Hochstrom 0,5 - 1,5 mm <sup>2</sup>	20 - 16	2000	TN01 016 0015 (1)	TN02 016 0015 (1)		
	1,5 - 2,5 mm <sup>2</sup>	18 - 14	2000	TN01 016 0016 (1)	TN02 016 0016 (1)		
Gedrehte Crimpkontakte / <i>Turned crimp contacts</i>							
Einzelkontakt <i>Single contact</i>	0,14 - 0,37 mm <sup>2</sup>	26 - 22	100	VN01 016 0024 (1)C	VN02 016 0024 (1)C	VN01 016 0024 (2)C	VN02 016 0024 (2)C
	0,5 mm <sup>2</sup>	20	100	VN01 016 0025 (1)C	VN02 016 0025 (1)C	VN01 016 0025 (2)C	VN02 016 0025 (2)C
	0,75 - 1,0 mm <sup>2</sup>	20 - 16	100	VN01 016 0026 (1)C	VN02 016 0026 (1)C	VN01 016 0026 (2)C	VN02 016 0026 (2)C
	1,5 mm <sup>2</sup>	16 - 15	100	VN01 016 0027 (1)C	VN02 016 0027 (1)C	VN01 016 0027 (2)C	VN02 016 0027 (2)C
	2,5 mm <sup>2</sup>	14	100	VN01 016 0028 (1)C	VN02 016 0028 (1)C	VN01 016 0028 (2)C	VN02 016 0028 (2)C
<b>Gestanzte Kontakte</b> <i>Stamped contacts</i>				<b>Gedrehte Kontakte</b> <i>Turned contacts</i>			
							
<b>Kurve / Curve</b>	<b>Kontakt / Contact</b>	<b>Querschnitt / Wire gauge</b>		<b>Kurve / Curve</b>	<b>Kontakt / Contact</b>	<b>Querschnitt / Wire gauge</b>	
a	Standard gestanzte	0,5 mm <sup>2</sup>		a	Standard gedrehte	0,5 mm <sup>2</sup>	
b	Standard gestanzte	1,5 mm <sup>2</sup>		b	Standard gedrehte	1,5 mm <sup>2</sup>	
c		2,5 mm <sup>2</sup>		c		2,5 mm <sup>2</sup>	
d	Hochstrom gestanzte	1,5 mm <sup>2</sup>					
e	Hochstrom gestanzte	2,5 mm <sup>2</sup>					

<sup>1)</sup> Erläuterung der Bestell-Nr. für die Kontakte siehe Seite 4  
<sup>1)</sup> Explanation of the Part No. for contacts see page 4

Abisolierlängen siehe S. 198  
Stripping length see p. 198







C 146 D

25 + 

Steckverbinder  
Connectors

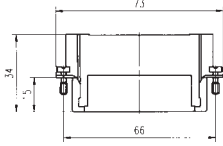
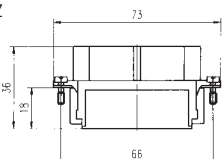
250 V~ 10 A/15 A DIN EN 175 301-801 (DIN 43 652)

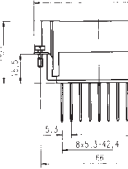
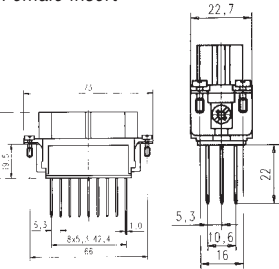
Gehäuse siehe Seite 118-121  
Housings see page 118-121

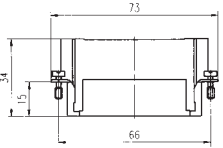
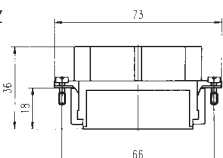
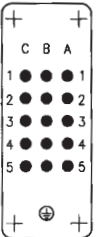
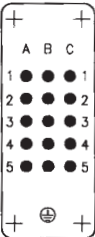
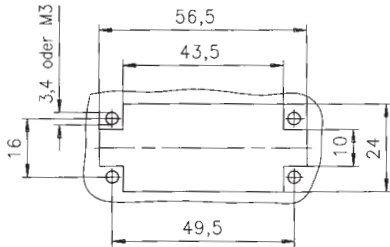
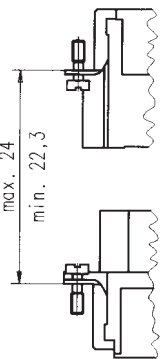
Bezeichnung - Abbildung Description - Figure	Maßzeichnung Drawing	Bestell Nr. / Part No.	
		Stifteinsatz / Male insert	Buchseinsatz / Female insert
Kontakteinsatz Contact insert  	Stifteinsatz Male insert    Buchseinsatz Female insert  	<b>C146 10A025 000 2</b> (für gestanzte Crimpkontakte) (for stamped crimp contacts)  <b>C146 10A025 500 2</b> (für gedrehte Crimpkontakte) (for turned crimp contacts)	<b>C146 10B025 000 2</b> (für gestanzte Crimpkontakte) (for stamped crimp contacts)  <b>C146 10B025 500 2</b> (für gedrehte Crimpkontakte) (for turned crimp contacts)
Wickelanschluss <sup>2)</sup> Wire wrap termination  	Stifteinsatz Male insert    Buchseinsatz Female insert  	<b>C146 10A025 009 2</b>	<b>C146 10B025 009 2</b>
Kontakteinsatz 2 X PE Anschluss <sup>1)</sup> Contact insert 2 X PE termination <sup>1)</sup>  	Stifteinsatz Male insert    Buchseinsatz Female insert  	<b>C146 10A025 060 2</b> (für gestanzte Crimpkontakte) (for stamped crimp contacts)	<b>C146 10B025 060 2</b> (für gestanzte Crimpkontakte) (for stamped crimp contacts)
Montageanleitung, Ansicht von Steckverbinder-Anschlussseite Assembly instructions, view from termination side			
Stifteinsatz Male insert  	Buchseinsatz Female insert  	Montageausschnitt (Kontaktträger) Panel cut out (insert)  	

<sup>1)</sup> Beim Einbau der Steckverbinder in nicht leitende Gehäuse sind beide Schutzleiter (Ausführung 2 x PE) anzuschließen.  
If connectors are mounted in non conductive housings both protective earthing terminals shall be mounted.

<sup>2)</sup> IP-Schutzart im Anschlussbereich IP 00  
IP-degree of protection on termination side IP 00

C 146 D

25 + 

**Crimpkontakte**  
**Crimp contacts**

Gestanzte Einzelkontakte  
*Stamped single contacts*



Gedrehte Einzelkontakte  
*Turned single contacts*



Gestanzte Bandkontakte für Crimpzangen  
*Stamped contacts on reel for hand crimping tools*



200 / 100 Stück

200 / 100 pcs

Gestanzte Bandkontakte für Crimpmaschinen  
*Stamped contacts on reel for crimp machines*

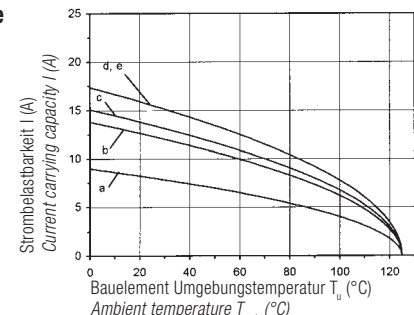
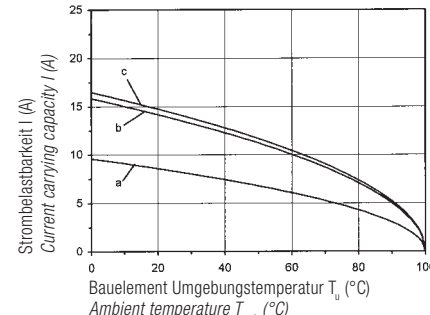

D

Lieferform <i>Supplied as</i>	für Leiter- querschnitt <i>for wire gauge</i>	AWG	Pieces	Bestell Nr. <sup>1)</sup> Stiftkontakt <i>Male contact</i>	Part No. <sup>1)</sup> Buchsenkontakt <i>Female contact</i>	Bestell Nr. <sup>1)</sup> Stiftkontakt <i>Male contact</i>	Part No. <sup>1)</sup> Buchsenkontakt <i>Female contact</i>
Gestanzte Einzelkontakte / <i>Stamped single contacts</i>				versilbert / <i>silver plating</i>		vergoldet / <i>gold plating</i>	
Standard Hochstrom <i>High current</i>	0,14 - 0,5 mm <sup>2</sup>	26 - 20	100	VN01 016 0003 (1)	VN02 016 0003 (1)	VN01 016 0003 (2)	VN02 016 0003 (2)
	0,5 - 1,5 mm <sup>2</sup>	20 - 16	100	VN01 016 0002 (1)	VN02 016 0002 (1)	VN01 016 0002 (2)	VN02 016 0002 (2)
	1,5 - 2,5 mm <sup>2</sup>	16 - 14	100	VN01 016 0005 (1)	VN02 016 0005 (1)	VN01 016 0005 (2)	VN02 016 0005 (2)
	0,5 - 1,5 mm <sup>2</sup>	20 - 16	100	VN01 016 0015 (1)	VN02 016 0015 (1)		
	1,5 - 2,5 mm <sup>2</sup>	16 - 14	100	VN01 016 0016 (1)	VN02 016 0016 (1)		
Gestanzte Bandkontakte für Crimpzangen / <i>Stamped Contacts on reel for hand crimp tools</i>							
Standard Hochstrom <i>High current</i>	0,14 - 0,5 mm <sup>2</sup>	26 - 20	200	ZN01 016 0003 (1)	ZN02 016 0003 (1)	ZN01 016 0003 (2)	ZN02 016 0003 (2)
	0,5 - 1,5 mm <sup>2</sup>	20 - 16	200	ZN01 016 0002 (1)	ZN02 016 0002 (1)	ZN01 016 0002 (2)	ZN02 016 0002 (2)
	1,5 - 2,5 mm <sup>2</sup>	16 - 14	100	ZN01 016 0005 (1)	ZN02 016 0005 (1)	ZN01 016 0005 (2)	ZN02 016 0005 (2)
	0,5 - 1,5 mm <sup>2</sup>	20 - 16	200	ZN01 016 0015 (1)	ZN02 016 0015 (1)		
	1,5 - 2,5 mm <sup>2</sup>	16 - 14	100	ZN01 016 0016 (1)	ZN02 016 0016 (1)		
Gestanzte Bandkontakte für Crimpmaschinen / <i>Stamped contacts on reel for crimp machines</i>							
Kontaktzuführung rechts <i>Contact feeding right hand side</i>	0,14 - 0,5 mm <sup>2</sup>	26 - 20	2000	HN01 016 0003 (1)	HN02 016 0003 (1)	HN01 016 0003 (2)	HN02 016 0003 (2)
	0,5 - 1,5 mm <sup>2</sup>	20 - 16	2000	HN01 016 0002 (1)	HN02 016 0002 (1)	HN01 016 0002 (2)	HN02 016 0002 (2)
	Standard 1,5 - 2,5 mm <sup>2</sup>	16 - 14	2000	HN01 016 0005 (1)	HN02 016 0005 (1)	HN01 016 0005 (2)	HN02 016 0005 (2)
	Hochstrom 0,5 - 1,5 mm <sup>2</sup>	20 - 16	2000	HN01 016 0015 (1)	HN02 016 0015 (1)		
	Hochstrom 1,5 - 2,5 mm <sup>2</sup>	16 - 14	2000	HN01 016 0016 (1)	HN02 016 0016 (1)		
Kontaktzuführung links <i>Contact feeding left hand side</i>	0,14 - 0,5 mm <sup>2</sup>	26 - 20	2000	TN01 016 0003 (1)	TN02 016 0003 (1)	TN01 016 0003 (2)	TN02 016 0003 (2)
	0,5 - 1,5 mm <sup>2</sup>	20 - 16	2000	TN01 016 0002 (1)	TN02 016 0002 (1)	TN01 016 0002 (2)	TN02 016 0002 (2)
	Standard 1,5 - 2,5 mm <sup>2</sup>	16 - 14	2000	TN01 016 0005 (1)	TN02 016 0005 (1)	TN01 016 0005 (2)	TN02 016 0005 (2)
	Hochstrom 0,5 - 1,5 mm <sup>2</sup>	20 - 16	2000	TN01 016 0015 (1)	TN02 016 0015 (1)		
	Hochstrom 1,5 - 2,5 mm <sup>2</sup>	18 - 14	2000	TN01 016 0016 (1)	TN02 016 0016 (1)		
Gedrehte Crimpkontakte / <i>Turned crimp contacts</i>							
Einzelkontakt <i>Single contact</i>	0,14 - 0,37 mm <sup>2</sup>	26 - 22	100	VN01 016 0024 (1)C	VN02 016 0024 (1)C	VN01 016 0024 (2)C	VN02 016 0024 (2)C
	0,5 mm <sup>2</sup>	20	100	VN01 016 0025 (1)C	VN02 016 0025 (1)C	VN01 016 0025 (2)C	VN02 016 0025 (2)C
	0,75 - 1,0 mm <sup>2</sup>	20 - 16	100	VN01 016 0026 (1)C	VN02 016 0026 (1)C	VN01 016 0026 (2)C	VN02 016 0026 (2)C
	1,5 mm <sup>2</sup>	16 - 15	100	VN01 016 0027 (1)C	VN02 016 0027 (1)C	VN01 016 0027 (2)C	VN02 016 0027 (2)C
	2,5 mm <sup>2</sup>	14	100	VN01 016 0028 (1)C	VN02 016 0028 (1)C	VN01 016 0028 (2)C	VN02 016 0028 (2)C
<b>Gestanzte Kontakte</b> <b>Stamped contacts</b> 				<b>Gedrehte Kontakte</b> <b>Turned contacts</b> 			
<b>Kurve / Curve</b>	<b>Kontakt / Contact</b>	<b>Querschnitt / Wire gauge</b>		<b>Kurve / Curve</b>	<b>Kontakt / Contact</b>	<b>Querschnitt / Wire gauge</b>	
a	Standard gestanzte	0,5 mm <sup>2</sup>		a	Standard gedrehte	0,5 mm <sup>2</sup>	
b	Standard gestanzte	1,5 mm <sup>2</sup>		b	Standard gedrehte	1,5 mm <sup>2</sup>	
c		2,5 mm <sup>2</sup>		c		2,5 mm <sup>2</sup>	
d	Hochstrom gestanzte	1,5 mm <sup>2</sup>					
e	Hochstrom gestanzte	2,5 mm <sup>2</sup>					

<sup>1)</sup> Erläuterung der Bestell-Nr. für die Kontakte siehe Seite 4  
<sup>1)</sup> Explanation of the Part No. for contacts see page 4

Abisolierlängen siehe S. 198  
Stripping length see p. 198

C 146 D

40 + 

Steckverbinder  
Connectors

250 V~ 10 A/15 A DIN EN 175 301-801 (DIN 43 652)

Gehäuse siehe Seite 138–145  
Housings see page 138–145

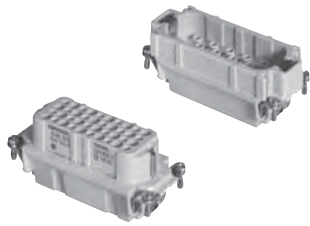
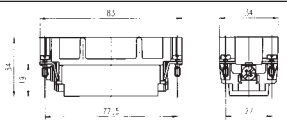
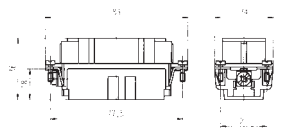
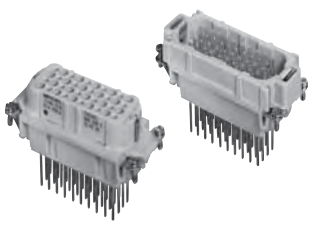
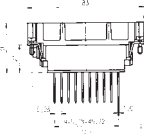
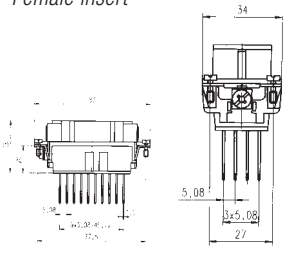
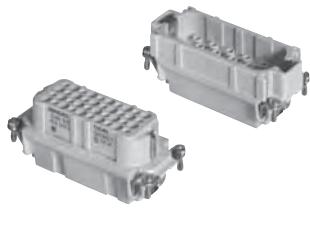
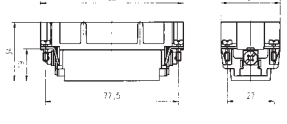
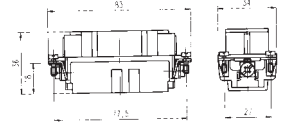
Bezeichnung - Abbildung Description - Figure	Maßzeichnung Drawing	Bestell Nr. / Part No.	
		Stifteinsatz / Male insert	Buchseinsatz / Female insert
Kontakteinsatz Contact insert  	Stifteinsatz Male insert  	C146 10A040 000 2 (für gestanzte Crimpkontakte) (for stamped crimp contacts)	C146 10B040 000 2 (für gestanzte Crimpkontakte) (for stamped crimp contacts)
	Buchseinsatz Female insert  	C146 10A040 500 2 (für gedrehte Crimpkontakte) (for turned crimp contacts)	C146 10B040 500 2 (für gedrehte Crimpkontakte) (for turned crimp contacts)
Wickelanschluss <sup>3)</sup> Wire wrap termination  	Stifteinsatz Male insert  	Buchseinsatz Female insert  	C146 10A040 009 2  C146 10B040 009 2
Kontakteinsatz 2 X PE Anschluss <sup>1)</sup> Contact insert 2 X PE termination <sup>1)</sup>  	Stifteinsatz Male insert  	C146 10A040 060 2 (für gestanzte Crimpkontakte) (for stamped crimp contacts)	C146 10B040 060 2 (für gestanzte Crimpkontakte) (for stamped crimp contacts)
	Buchseinsatz Female insert  		

Montageanleitung, Ansicht von Steckverbinder-Anschlussseite / Assembly instructions, view from termination side

Stifteinsatz  
Male insert

Buchseinsatz  
Female insert

Montageausschnitt (Kontaktträger)  
Panel cut out (insert)

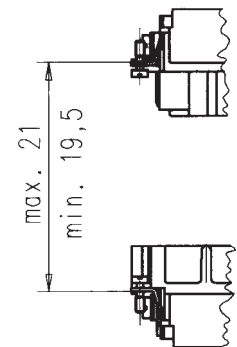
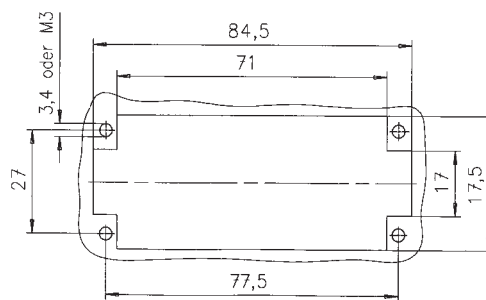
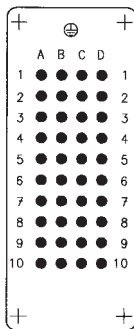
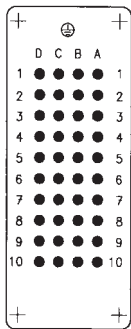

<sup>1)</sup> Beim Einbau der Steckverbinder in nicht leitende Gehäuse sind beide Schutzleiter (Ausführung 2 x PE) anzuschließen.  
If connectors are mounted in non conductive housings both protective earthing terminals shall be mounted.

<sup>2)</sup> Für Gehäuse mit niedriger Bauform / for low profile housings

<sup>3)</sup> IP-Schutzart im Anschlussbereich IP 00  
IP-degree of protection on termination side IP 00

C 146 D

40 + 

**Crimpkontakte**  
*Crimp contacts*

Gestanzte Einzelkontakte  
*Stamped single contacts*



Gedrehte Einzelkontakte  
*Turned single contacts*



Gestanzte Bandkontakte für Crimpzangen  
*Stamped contacts on reel for hand crimping tools*



200 / 100 Stück  
200 / 100 pcs

Gestanzte Bandkontakte für Crimpmaschinen  
*Stamped contacts on reel for crimp machines*



2000 Stück  
(Zuführung links  
oder rechts)  
2000 pcs  
(feeding left or  
right hand side)

D

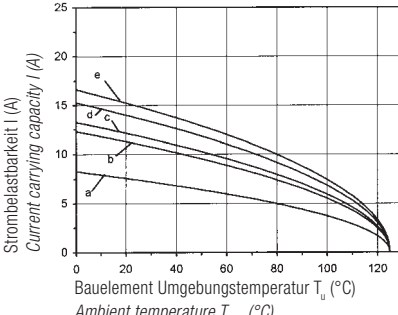
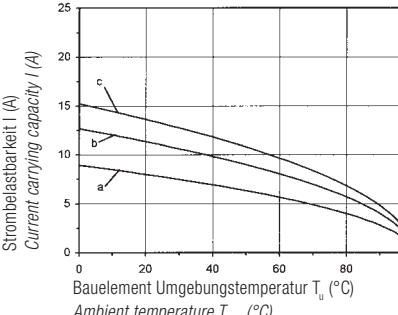
Lieferform <i>Supplied as</i>	für Leiter- querschnitt <i>for wire gauge</i>	AWG	Stück- zahl <i>Pieces</i>	Bestell Nr. <sup>1)</sup> Stiftkontakt <i>Male contact</i>	Part No. <sup>1)</sup> Buchsenkontakt <i>Female contact</i>	Bestell Nr. <sup>1)</sup> Stiftkontakt <i>Male contact</i>	Part No. <sup>1)</sup> Buchsenkontakt <i>Female contact</i>
Gestanzte Einzelkontakte / <i>Stamped single contacts</i>				versilbert / <i>silver plating</i>		vergoldet / <i>gold plating</i>	
Standard Hochstrom <i>High current</i>	0,14 - 0,5 mm <sup>2</sup>	26 - 20	100	VN01 016 0003 (1)	VN02 016 0003 (1)	VN01 016 0003 (2)	VN02 016 0003 (2)
	0,5 - 1,5 mm <sup>2</sup>	20 - 16	100	VN01 016 0002 (1)	VN02 016 0002 (1)	VN01 016 0002 (2)	VN02 016 0002 (2)
	1,5 - 2,5 mm <sup>2</sup>	16 - 14	100	VN01 016 0005 (1)	VN02 016 0005 (1)	VN01 016 0005 (2)	VN02 016 0005 (2)
	0,5 - 1,5 mm <sup>2</sup>	20 - 16	100	VN01 016 0015 (1)	VN02 016 0015 (1)		
	1,5 - 2,5 mm <sup>2</sup>	16 - 14	100	VN01 016 0016 (1)	VN02 016 0016 (1)		
Gestanzte Bandkontakte für Crimpzangen / <i>Stamped Contacts on reel for hand crimp tools</i>							
Standard Hochstrom <i>High current</i>	0,14 - 0,5 mm <sup>2</sup>	26 - 20	200	ZN01 016 0003 (1)	ZN02 016 0003 (1)	ZN01 016 0003 (2)	ZN02 016 0003 (2)
	0,5 - 1,5 mm <sup>2</sup>	20 - 16	200	ZN01 016 0002 (1)	ZN02 016 0002 (1)	ZN01 016 0002 (2)	ZN02 016 0002 (2)
	1,5 - 2,5 mm <sup>2</sup>	16 - 14	100	ZN01 016 0005 (1)	ZN02 016 0005 (1)	ZN01 016 0005 (2)	ZN02 016 0005 (2)
	0,5 - 1,5 mm <sup>2</sup>	20 - 16	200	ZN01 016 0015 (1)	ZN02 016 0015 (1)		
	1,5 - 2,5 mm <sup>2</sup>	16 - 14	100	ZN01 016 0016 (1)	ZN02 016 0016 (1)		
Gestanzte Bandkontakte für Crimpmaschinen / <i>Stamped contacts on reel for crimp machines</i>							
Kontaktzuführung rechts <i>Contact feeding right hand side</i>	0,14 - 0,5 mm <sup>2</sup>	26 - 20	2000	HN01 016 0003 (1)	HN02 016 0003 (1)	HN01 016 0003 (2)	HN02 016 0003 (2)
	0,5 - 1,5 mm <sup>2</sup>	20 - 16	2000	HN01 016 0002 (1)	HN02 016 0002 (1)	HN01 016 0002 (2)	HN02 016 0002 (2)
	Standard 1,5 - 2,5 mm <sup>2</sup>	16 - 14	2000	HN01 016 0005 (1)	HN02 016 0005 (1)	HN01 016 0005 (2)	HN02 016 0005 (2)
	Hochstrom 1,5 - 2,5 mm <sup>2</sup>	16 - 14	2000	HN01 016 0015 (1)	HN02 016 0015 (1)		
	1,5 - 2,5 mm <sup>2</sup>	16 - 14	2000	HN01 016 0016 (1)	HN02 016 0016 (1)		
Kontaktzuführung links <i>Contact feeding left hand side</i>	0,14 - 0,5 mm <sup>2</sup>	26 - 20	2000	TN01 016 0003 (1)	TN02 016 0003 (1)	TN01 016 0003 (2)	TN02 016 0003 (2)
	0,5 - 1,5 mm <sup>2</sup>	20 - 16	2000	TN01 016 0002 (1)	TN02 016 0002 (1)	TN01 016 0002 (2)	TN02 016 0002 (2)
	Standard 1,5 - 2,5 mm <sup>2</sup>	16 - 14	2000	TN01 016 0005 (1)	TN02 016 0005 (1)	TN01 016 0005 (2)	TN02 016 0005 (2)
	Hochstrom 0,5 - 1,5 mm <sup>2</sup>	20 - 16	2000	TN01 016 0015 (1)	TN02 016 0015 (1)		
	1,5 - 2,5 mm <sup>2</sup>	18 - 14	2000	TN01 016 0016 (1)	TN02 016 0016 (1)		
Gedrehte Crimpkontakte / <i>Turned crimp contacts</i>							
Einzelkontakt <i>Single contact</i>	0,14 - 0,37 mm <sup>2</sup>	26 - 22	100	VN01 016 0024 (1)C	VN02 016 0024 (1)C	VN01 016 0024 (2)C	VN02 016 0024 (2)C
	0,5 mm <sup>2</sup>	20	100	VN01 016 0025 (1)C	VN02 016 0025 (1)C	VN01 016 0025 (2)C	VN02 016 0025 (2)C
	0,75 - 1,0 mm <sup>2</sup>	20 - 16	100	VN01 016 0026 (1)C	VN02 016 0026 (1)C	VN01 016 0026 (2)C	VN02 016 0026 (2)C
	1,5 mm <sup>2</sup>	16 - 15	100	VN01 016 0027 (1)C	VN02 016 0027 (1)C	VN01 016 0027 (2)C	VN02 016 0027 (2)C
	2,5 mm <sup>2</sup>	14	100	VN01 016 0028 (1)C	VN02 016 0028 (1)C	VN01 016 0028 (2)C	VN02 016 0028 (2)C
<b>Gestanzte Kontakte</b> <i>Stamped contacts</i>				<b>Gedrehte Kontakte</b> <i>Turned contacts</i>			
							
<b>Kurve / Curve</b>	<b>Kontakt / Contact</b>	<b>Querschnitt / Wire gauge</b>		<b>Kurve / Curve</b>	<b>Kontakt / Contact</b>	<b>Querschnitt / Wire gauge</b>	
a	Standard gestanzte	0,5 mm <sup>2</sup>		a	Standard gedrehte	0,5 mm <sup>2</sup>	
b	Standard gestanzte	1,5 mm <sup>2</sup>		b	Standard gedrehte	1,5 mm <sup>2</sup>	
c		2,5 mm <sup>2</sup>		c		2,5 mm <sup>2</sup>	
d	Hochstrom gestanzte	1,5 mm <sup>2</sup>					
e	Hochstrom gestanzte	2,5 mm <sup>2</sup>					

<sup>1)</sup> Erläuterung der Bestell-Nr. für die Kontakte siehe Seite 4  
<sup>1)</sup> Explanation of the Part No. for contacts see page 4

Abisolierlängen siehe S. 198  
Stripping length see p. 198





C 146 D

50 + 

Steckverbinder  
Connectors

250 V~ 10 A/15 A

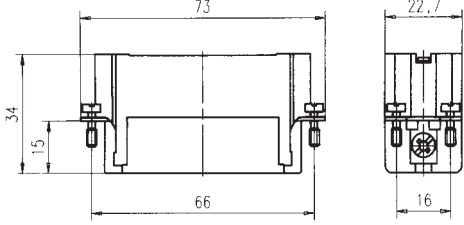
Gehäuse siehe Seite 122-125  
Housings see page 122-125

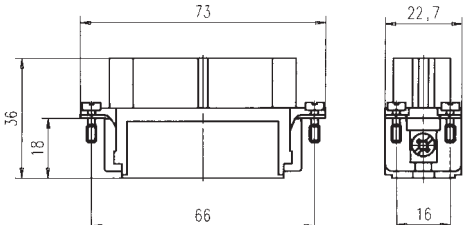
Bezeichnung - Abbildung Description - Figure	Maßzeichnung Drawing	Bestell Nr. / Part No.	
		Stifteinsatz / Male insert	Buchseinsatz / Female insert
<p>Kontakteinsatz Contact insert</p> 	<p>Stifteinsatz Male insert</p> 	<p>C146 10A025 000 2 + C146 10A025 005 2 (für gestanzte Crimpkontakte) (for stamped crimp contacts)</p> <p>C146 10A025 500 2 + C146 10A025 505 2 (für gedrehte Crimpkontakte) (for turned crimp contacts)</p>	<p>C146 10B025 000 2 + C146 10B025 005 2 (für gestanzte Crimpkontakte) (for stamped crimp contacts)</p> <p>C146 10B025 500 2 + C146 10B025 505 2 (für gedrehte Crimpkontakte) (for turned crimp contacts)</p>
	<p>Buchseinsatz Female insert</p> 		

Montageanleitung, Ansicht von Steckverbinder-Anschlussseite / Assembly instructions, view from termination side

Stifteinsatz  
Male insert

Buchseinsatz  
Female insert

Montageausschnitt (Kontaktträger)  
Panel cut out (insert)

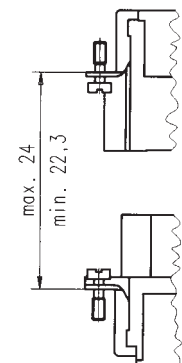
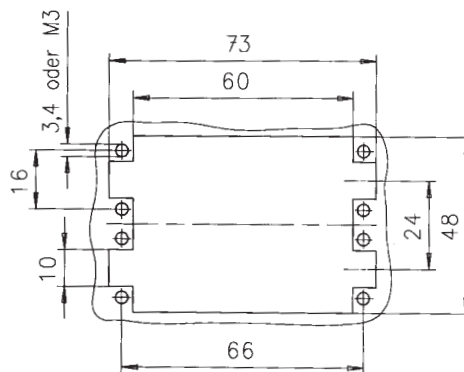
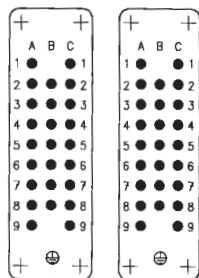
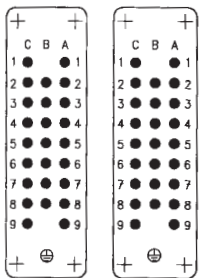

C 146 D

50 +

**Crimpkontakte**  
Crimp contacts

Gestanzte Einzelkontakte  
Stamped single contacts



Gedrehte Einzelkontakte  
Turned single contacts



Gestanzte Bandkontakte für Crimpzangen  
Stamped contacts on reel for hand crimping tools



200 / 100 Stück  
200 / 100 pcs

Gestanzte Bandkontakte für Crimpmaschinen  
Stamped contacts on reel for crimp machines



2000 Stück  
(Zuführung links  
oder rechts)  
2000 pcs  
(feeding left or  
right hand side)

D

Lieferform Supplied as	für Leiter- querschnitt for wire gauge	AWG	Stück- zahl Pieces	Bestell Nr. <sup>1)</sup> Stiftkontakt Male contact	Part No. <sup>1)</sup> Buchsenkontakt Female contact	Bestell Nr. <sup>1)</sup> Stiftkontakt Male contact	Part No. <sup>1)</sup> Buchsenkontakt Female contact
Gestanzte Einzelkontakte / Stamped single contacts				versilbert / silver plating		vergoldet / gold plating	
Standard Hochstrom High current	0,14 - 0,5 mm <sup>2</sup>	26 - 20	100	VN01 016 0003 (1)	VN02 016 0003 (1)	VN01 016 0003 (2)	VN02 016 0003 (2)
	0,5 - 1,5 mm <sup>2</sup>	20 - 16	100	VN01 016 0002 (1)	VN02 016 0002 (1)	VN01 016 0002 (2)	VN02 016 0002 (2)
	1,5 - 2,5 mm <sup>2</sup>	16 - 14	100	VN01 016 0005 (1)	VN02 016 0005 (1)	VN01 016 0005 (2)	VN02 016 0005 (2)
	0,5 - 1,5 mm <sup>2</sup>	20 - 16	100	VN01 016 0015 (1)	VN02 016 0015 (1)		
	1,5 - 2,5 mm <sup>2</sup>	16 - 14	100	VN01 016 0016 (1)	VN02 016 0016 (1)		
Gestanzte Bandkontakte für Crimpzangen / Stamped Contacts on reel for hand crimp tools							
Standard Hochstrom High current	0,14 - 0,5 mm <sup>2</sup>	26 - 20	200	ZN01 016 0003 (1)	ZN02 016 0003 (1)	ZN01 016 0003 (2)	ZN02 016 0003 (2)
	0,5 - 1,5 mm <sup>2</sup>	20 - 16	200	ZN01 016 0002 (1)	ZN02 016 0002 (1)	ZN01 016 0002 (2)	ZN02 016 0002 (2)
	1,5 - 2,5 mm <sup>2</sup>	16 - 14	100	ZN01 016 0005 (1)	ZN02 016 0005 (1)	ZN01 016 0005 (2)	ZN02 016 0005 (2)
	0,5 - 1,5 mm <sup>2</sup>	20 - 16	200	ZN01 016 0015 (1)	ZN02 016 0015 (1)		
	1,5 - 2,5 mm <sup>2</sup>	16 - 14	100	ZN01 016 0016 (1)	ZN02 016 0016 (1)		
Gestanzte Bandkontakte für Crimpmaschinen / Stamped contacts on reel for crimp machines							
Kontaktzuführung rechts Contact feeding right hand side	0,14 - 0,5 mm <sup>2</sup>	26 - 20	2000	HN01 016 0003 (1)	HN02 016 0003 (1)	HN01 016 0003 (2)	HN02 016 0003 (2)
	0,5 - 1,5 mm <sup>2</sup>	20 - 16	2000	HN01 016 0002 (1)	HN02 016 0002 (1)	HN01 016 0002 (2)	HN02 016 0002 (2)
	1,5 - 2,5 mm <sup>2</sup>	16 - 14	2000	HN01 016 0005 (1)	HN02 016 0005 (1)	HN01 016 0005 (2)	HN02 016 0005 (2)
	0,5 - 1,5 mm <sup>2</sup>	20 - 16	2000	HN01 016 0015 (1)	HN02 016 0015 (1)		
	1,5 - 2,5 mm <sup>2</sup>	16 - 14	2000	HN01 016 0016 (1)	HN02 016 0016 (1)		
Kontaktzuführung links Contact feeding left hand side	0,14 - 0,5 mm <sup>2</sup>	26 - 20	2000	TN01 016 0003 (1)	TN02 016 0003 (1)	TN01 016 0003 (2)	TN02 016 0003 (2)
	0,5 - 1,5 mm <sup>2</sup>	20 - 16	2000	TN01 016 0002 (1)	TN02 016 0002 (1)	TN01 016 0002 (2)	TN02 016 0002 (2)
	1,5 - 2,5 mm <sup>2</sup>	16 - 14	2000	TN01 016 0005 (1)	TN02 016 0005 (1)	TN01 016 0005 (2)	TN02 016 0005 (2)
	0,5 - 1,5 mm <sup>2</sup>	20 - 16	2000	TN01 016 0015 (1)	TN02 016 0015 (1)		
	1,5 - 2,5 mm <sup>2</sup>	18 - 14	2000	TN01 016 0016 (1)	TN02 016 0016 (1)		
Gedrehte Crimpkontakte / Turned crimp contacts							
Einzelkontakt Single contact	0,14 - 0,37 mm <sup>2</sup>	26 - 22	100	VN01 016 0024 (1)C	VN02 016 0024 (1)C	VN01 016 0024 (2)C	VN02 016 0024 (2)C
	0,5 mm <sup>2</sup>	20	100	VN01 016 0025 (1)C	VN02 016 0025 (1)C	VN01 016 0025 (2)C	VN02 016 0025 (2)C
	0,75 - 1,0 mm <sup>2</sup>	20 - 16	100	VN01 016 0026 (1)C	VN02 016 0026 (1)C	VN01 016 0026 (2)C	VN02 016 0026 (2)C
	1,5 mm <sup>2</sup>	16 - 15	100	VN01 016 0027 (1)C	VN02 016 0027 (1)C	VN01 016 0027 (2)C	VN02 016 0027 (2)C
	2,5 mm <sup>2</sup>	14	100	VN01 016 0028 (1)C	VN02 016 0028 (1)C	VN01 016 0028 (2)C	VN02 016 0028 (2)C
<b>Gestanzte Kontakte</b> Stamped contacts				<b>Gedrehte Kontakte</b> Turned contacts			
<b>Kurve / Curve</b>	<b>Kontakt / Contact</b>	<b>Querschnitt / Wire gauge</b>		<b>Kurve / Curve</b>	<b>Kontakt / Contact</b>	<b>Querschnitt / Wire gauge</b>	
a	Standard gestanzte	0,5 mm <sup>2</sup>		a	Standard gedrehte	0,5 mm <sup>2</sup>	
b	Standard gestanzte	1,5 mm <sup>2</sup>		b	Standard gedrehte	1,5 mm <sup>2</sup>	
c		2,5 mm <sup>2</sup>		c		2,5 mm <sup>2</sup>	
d	Hochstrom gestanzte	1,5 mm <sup>2</sup>					
e	Hochstrom gestanzte	2,5 mm <sup>2</sup>					

<sup>1)</sup> Erläuterung der Bestell-Nr. für die Kontakte siehe Seite 4  
<sup>1)</sup> Explanation of the Part No. for contacts see page 4

Abisolierlängen siehe S. 198  
Stripping length see p. 198

C 146 D

64 + 

Steckverbinder  
Connectors

250 V~ 10 A/15 A DIN EN 175 301-801 (DIN 43 652)

Gehäuse siehe Seite 146-153  
Housings see page 146-153

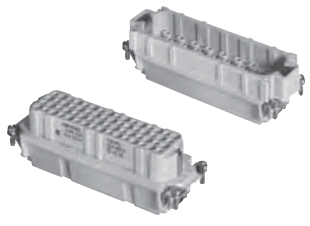
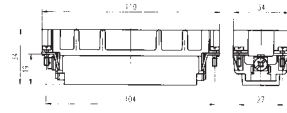
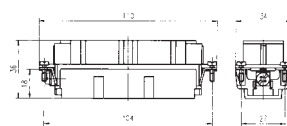
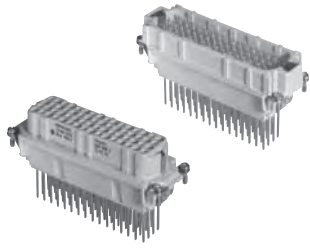
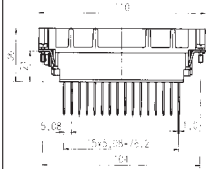
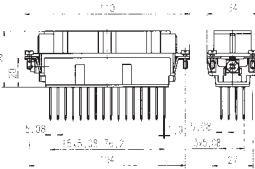
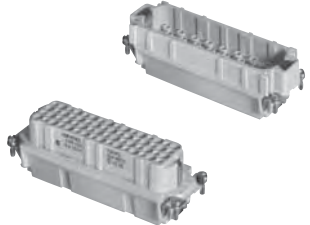
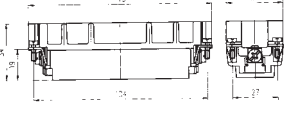
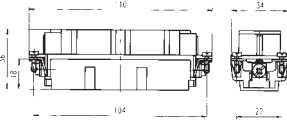
Bezeichnung - Abbildung Description - Figure	Maßzeichnung Drawing	Bestell Nr. / Part No.	
		Stifteinsatz / Male insert	Buchseinsatz / Female insert
Kontakteinsatz Contact insert  	Stifteinsatz Male insert    Buchseinsatz Female insert  	C146 10A064 000 2 (für gestanzte Crimpkontakte) (for stamped crimp contacts)	C146 10B064 000 2 (für gestanzte Crimpkontakte) (for stamped crimp contacts)
		C146 10A064 500 2 (für gedrehte Crimpkontakte) (for turned crimp contacts)	C146 10B064 500 2 (für gedrehte Crimpkontakte) (for turned crimp contacts)
Wickelanschluss <sup>3)</sup> Wire wrap termination  	Stifteinsatz Male insert    Buchseinsatz Female insert  	C146 10A064 009 2	C146 10B064 009 2
Kontakteinsatz 2 X PE Anschluss <sup>1)</sup> Contact insert 2 X PE termination <sup>1)</sup>  	Stifteinsatz Male insert    Buchseinsatz Female insert  	C146 10A064 060 2 (für gestanzte Crimpkontakte) (for stamped crimp contacts)	C146 10B064 060 2 (für gestanzte Crimpkontakte) (for stamped crimp contacts)

Montageanleitung, Ansicht von Steckverbinder-Anschlussseite / Assembly instructions, view from termination side

Stifteinsatz  
Male insert

Buchseinsatz  
Female insert

Montageausschnitt (Kontaktträger)  
Panel cut out (insert)

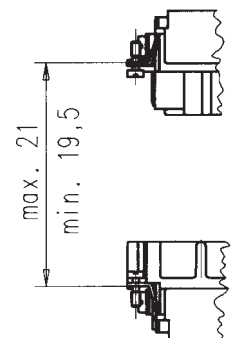
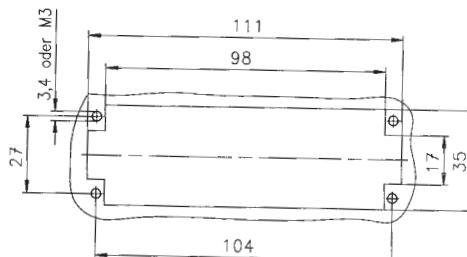
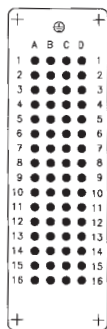
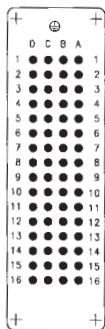

<sup>1)</sup> Beim Einbau der Steckverbinder in nicht leitende Gehäuse sind beide Schutzleiter (Ausführung 2 x PE) anzuschließen.  
If connectors are mounted in non conductive housings both protective earthing terminals shall be mounted.

<sup>2)</sup> Für Gehäuse mit niedriger Bauform / for low profile housings

<sup>3)</sup> IP-Schutzart im Anschlussbereich IP 00  
IP-degree of protection on termination side IP 00

C 146 D

64 + 

**Crimpkontakte**  
*Crimp contacts*

Gestanzte Einzelkontakte  
*Stamped single contacts*



Gedrehte Einzelkontakte  
*Turned single contacts*



Gestanzte Bandkontakte für Crimpzangen  
*Stamped contacts on reel for hand crimping tools*



200 / 100 Stück  
200 / 100 pcs

Gestanzte Bandkontakte für Crimpmaschinen  
*Stamped contacts on reel for crimp machines*



2000 Stück  
(Zuführung links  
oder rechts)  
2000 pcs  
(feeding left or  
right hand side)

D

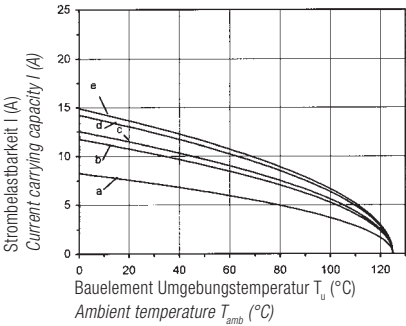
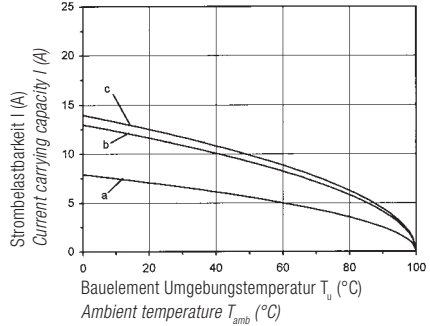
Lieferform <i>Supplied as</i>	für Leiter- querschnitt <i>for wire gauge</i>	AWG	Stück- zahl <i>Pieces</i>	Bestell Nr. <sup>1)</sup> Stiftkontakt <i>Male contact</i>	Part No. <sup>1)</sup> Buchsenkontakt <i>Female contact</i>	Bestell Nr. <sup>1)</sup> Stiftkontakt <i>Male contact</i>	Part No. <sup>1)</sup> Buchsenkontakt <i>Female contact</i>
Gestanzte Einzelkontakte / <i>Stamped single contacts</i>				versilbert / <i>silver plating</i>		vergoldet / <i>gold plating</i>	
Standard Hochstrom <i>High current</i>	0,14 - 0,5 mm <sup>2</sup>	26 - 20	100	VN01 016 0003 (1)	VN02 016 0003 (1)	VN01 016 0003 (2)	VN02 016 0003 (2)
	0,5 - 1,5 mm <sup>2</sup>	20 - 16	100	VN01 016 0002 (1)	VN02 016 0002 (1)	VN01 016 0002 (2)	VN02 016 0002 (2)
	1,5 - 2,5 mm <sup>2</sup>	16 - 14	100	VN01 016 0005 (1)	VN02 016 0005 (1)	VN01 016 0005 (2)	VN02 016 0005 (2)
	0,5 - 1,5 mm <sup>2</sup>	20 - 16	100	VN01 016 0015 (1)	VN02 016 0015 (1)		
	1,5 - 2,5 mm <sup>2</sup>	16 - 14	100	VN01 016 0016 (1)	VN02 016 0016 (1)		
Gestanzte Bandkontakte für Crimpzangen / <i>Stamped Contacts on reel for hand crimp tools</i>							
Standard Hochstrom <i>High current</i>	0,14 - 0,5 mm <sup>2</sup>	26 - 20	200	ZN01 016 0003 (1)	ZN02 016 0003 (1)	ZN01 016 0003 (2)	ZN02 016 0003 (2)
	0,5 - 1,5 mm <sup>2</sup>	20 - 16	200	ZN01 016 0002 (1)	ZN02 016 0002 (1)	ZN01 016 0002 (2)	ZN02 016 0002 (2)
	1,5 - 2,5 mm <sup>2</sup>	16 - 14	100	ZN01 016 0005 (1)	ZN02 016 0005 (1)	ZN01 016 0005 (2)	ZN02 016 0005 (2)
	0,5 - 1,5 mm <sup>2</sup>	20 - 16	200	ZN01 016 0015 (1)	ZN02 016 0015 (1)		
	1,5 - 2,5 mm <sup>2</sup>	16 - 14	100	ZN01 016 0016 (1)	ZN02 016 0016 (1)		
Gestanzte Bandkontakte für Crimpmaschinen / <i>Stamped contacts on reel for crimp machines</i>							
Kontaktzuführung rechts <i>Contact feeding right hand side</i>	0,14 - 0,5 mm <sup>2</sup>	26 - 20	2000	HN01 016 0003 (1)	HN02 016 0003 (1)	HN01 016 0003 (2)	HN02 016 0003 (2)
	0,5 - 1,5 mm <sup>2</sup>	20 - 16	2000	HN01 016 0002 (1)	HN02 016 0002 (1)	HN01 016 0002 (2)	HN02 016 0002 (2)
	Standard 1,5 - 2,5 mm <sup>2</sup>	16 - 14	2000	HN01 016 0005 (1)	HN02 016 0005 (1)	HN01 016 0005 (2)	HN02 016 0005 (2)
	Hochstrom 1,5 - 2,5 mm <sup>2</sup>	20 - 16	2000	HN01 016 0015 (1)	HN02 016 0015 (1)		
	1,5 - 2,5 mm <sup>2</sup>	16 - 14	2000	HN01 016 0016 (1)	HN02 016 0016 (1)		
Kontaktzuführung links <i>Contact feeding left hand side</i>	0,14 - 0,5 mm <sup>2</sup>	26 - 20	2000	TN01 016 0003 (1)	TN02 016 0003 (1)	TN01 016 0003 (2)	TN02 016 0003 (2)
	0,5 - 1,5 mm <sup>2</sup>	20 - 16	2000	TN01 016 0002 (1)	TN02 016 0002 (1)	TN01 016 0002 (2)	TN02 016 0002 (2)
	Standard 1,5 - 2,5 mm <sup>2</sup>	16 - 14	2000	TN01 016 0005 (1)	TN02 016 0005 (1)	TN01 016 0005 (2)	TN02 016 0005 (2)
	Hochstrom 0,5 - 1,5 mm <sup>2</sup>	20 - 16	2000	TN01 016 0015 (1)	TN02 016 0015 (1)		
	1,5 - 2,5 mm <sup>2</sup>	18 - 14	2000	TN01 016 0016 (1)	TN02 016 0016 (1)		
Gedrehte Crimpkontakte / <i>Turned crimp contacts</i>							
Einzelkontakt <i>Single contact</i>	0,14 - 0,37 mm <sup>2</sup>	26 - 22	100	VN01 016 0024 (1)C	VN02 016 0024 (1)C	VN01 016 0024 (2)C	VN02 016 0024 (2)C
	0,5 mm <sup>2</sup>	20	100	VN01 016 0025 (1)C	VN02 016 0025 (1)C	VN01 016 0025 (2)C	VN02 016 0025 (2)C
	0,75 - 1,0 mm <sup>2</sup>	20 - 16	100	VN01 016 0026 (1)C	VN02 016 0026 (1)C	VN01 016 0026 (2)C	VN02 016 0026 (2)C
	1,5 mm <sup>2</sup>	16 - 15	100	VN01 016 0027 (1)C	VN02 016 0027 (1)C	VN01 016 0027 (2)C	VN02 016 0027 (2)C
	2,5 mm <sup>2</sup>	14	100	VN01 016 0028 (1)C	VN02 016 0028 (1)C	VN01 016 0028 (2)C	VN02 016 0028 (2)C
<b>Gestanzte Kontakte</b> <i>Stamped contacts</i> 				<b>Gedrehte Kontakte</b> <i>Turned contacts</i> 			
<b>Kurve / Curve</b>	<b>Kontakt / Contact</b>	<b>Querschnitt / Wire gauge</b>		<b>Kurve / Curve</b>	<b>Kontakt / Contact</b>	<b>Querschnitt / Wire gauge</b>	
a	Standard gestanzte	0,5 mm <sup>2</sup>		a	Standard gedrehte	0,5 mm <sup>2</sup>	
b	Standard gestanzte	1,5 mm <sup>2</sup>		b	Standard gedrehte	1,5 mm <sup>2</sup>	
c		2,5 mm <sup>2</sup>		c		2,5 mm <sup>2</sup>	
d	Hochstrom gestanzte	1,5 mm <sup>2</sup>					
e	High current, stamped	2,5 mm <sup>2</sup>					

<sup>1)</sup> Erläuterung der Bestell-Nr. für die Kontakte siehe Seite 4  
<sup>1)</sup> Explanation of the Part No. for contacts see page 4

Abisolierlängen siehe S. 198  
Stripping length see p. 198



C 146 D

128 + 

Steckverbinder  
Connectors

250 V~ 10 A/15 A

Gehäuse auf Anfrage  
Housings upon request

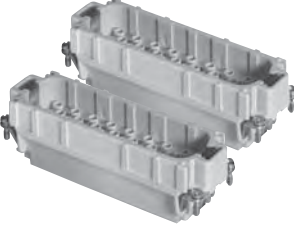
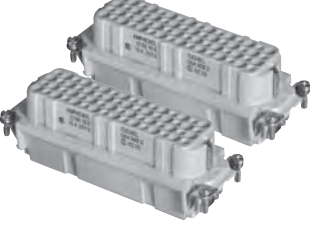
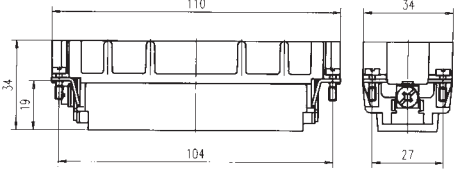
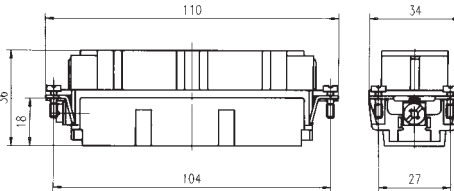
Bezeichnung - Abbildung Description - Figure	Maßzeichnung Drawing	Bestell Nr. / Part No.	
		Stifteinsatz / Male insert	Buchseinsatz / Female insert
Kontakteinsatz Contact insert    	Stifteinsatz Male insert    Buchseinsatz Female insert  	C146 10A064 000 2 + C146 10A064 005 2 (für gestanzte Crimpkontakte) (for stamped crimp contacts)  C146 10A064 500 2 + C146 10A064 505 2 (für gedrehte Crimpkontakte) (for turned crimp contacts)	C146 10B064 000 2 + C146 10B064 005 2 (für gestanzte Crimpkontakte) (for stamped crimp contacts)  C146 10B064 500 2 + C146 10B064 505 2 (für gedrehte Crimpkontakte) (for turned crimp contacts)

Montageanleitung, Ansicht von Steckverbinder-Anschlussseite / Assembly instructions, view from termination side

Stifteinsatz  
Male insert

Buchseinsatz  
Female insert

Montageausschnitt (Kontaktträger)  
Panel cut out (insert)

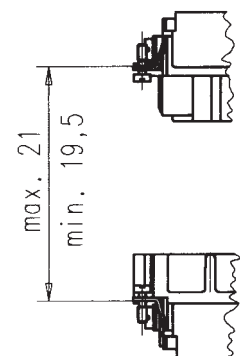
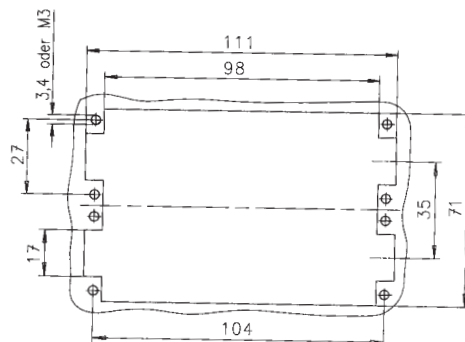
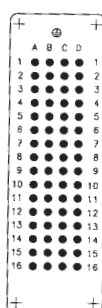
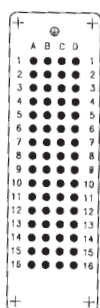
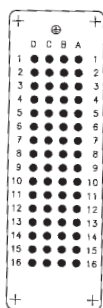
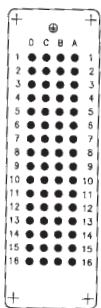

C 146 D

128 + 

**Crimpkontakte**  
*Crimp contacts*

Gestanzte Einzelkontakte  
*Stamped single contacts*



Gedrehte Einzelkontakte  
*Closed turned single contacts*



Gestanzte Bandkontakte für Crimpzangen  
*Stamped contacts on reel for hand crimping tools*



200 / 100 Stück  
200 / 100 pcs

Gestanzte Bandkontakte für Crimpmaschinen  
*Stamped contacts on reel for crimp machines*



2000 Stück  
(Zuführung links oder rechts)  
2000 pcs  
(feeding left or right hand side)

D

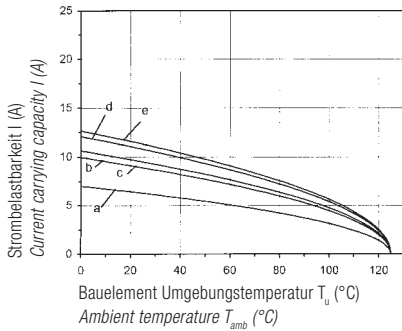
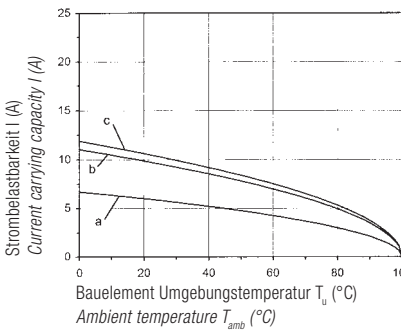
Lieferform <i>Supplied as</i>	für Leiter- querschnitt <i>for wire gauge</i>	AWG	Stück- zahl <i>Pieces</i>	Bestell Nr. <sup>1)</sup> Stiftkontakt <i>Male contact</i>	Part No. <sup>1)</sup> Buchsenkontakt <i>Female contact</i>	Bestell Nr. <sup>1)</sup> Stiftkontakt <i>Male contact</i>	Part No. <sup>1)</sup> Buchsenkontakt <i>Female contact</i>
Gestanzte Einzelkontakte / <i>Stamped single contacts</i>				versilbert / <i>silver plating</i>		vergoldet / <i>gold plating</i>	
Standard Hochstrom <i>High current</i>	0,14 - 0,5 mm <sup>2</sup>	26 - 20	100	VN01 016 0003 (1)	VN02 016 0003 (1)	VN01 016 0003 (2)	VN02 016 0003 (2)
	0,5 - 1,5 mm <sup>2</sup>	20 - 16	100	VN01 016 0002 (1)	VN02 016 0002 (1)	VN01 016 0002 (2)	VN02 016 0002 (2)
	1,5 - 2,5 mm <sup>2</sup>	16 - 14	100	VN01 016 0005 (1)	VN02 016 0005 (1)	VN01 016 0005 (2)	VN02 016 0005 (2)
	0,5 - 1,5 mm <sup>2</sup>	20 - 16	100	VN01 016 0015 (1)	VN02 016 0015 (1)		
	1,5 - 2,5 mm <sup>2</sup>	16 - 14	100	VN01 016 0016 (1)	VN02 016 0016 (1)		
Gestanzte Bandkontakte für Crimpzangen / <i>Stamped Contacts on reel for hand crimp tools</i>							
Standard Hochstrom <i>High current</i>	0,14 - 0,5 mm <sup>2</sup>	26 - 20	200	ZN01 016 0003 (1)	ZN02 016 0003 (1)	ZN01 016 0003 (2)	ZN02 016 0003 (2)
	0,5 - 1,5 mm <sup>2</sup>	20 - 16	200	ZN01 016 0002 (1)	ZN02 016 0002 (1)	ZN01 016 0002 (2)	ZN02 016 0002 (2)
	1,5 - 2,5 mm <sup>2</sup>	16 - 14	100	ZN01 016 0005 (1)	ZN02 016 0005 (1)	ZN01 016 0005 (2)	ZN02 016 0005 (2)
	0,5 - 1,5 mm <sup>2</sup>	20 - 16	200	ZN01 016 0015 (1)	ZN02 016 0015 (1)		
	1,5 - 2,5 mm <sup>2</sup>	16 - 14	100	ZN01 016 0016 (1)	ZN02 016 0016 (1)		
Gestanzte Bandkontakte für Crimpmaschinen / <i>Stamped contacts on reel for crimp machines</i>							
Kontaktzuführung rechts <i>Contact feeding right hand side</i>	0,14 - 0,5 mm <sup>2</sup>	26 - 20	2000	HN01 016 0003 (1)	HN02 016 0003 (1)	HN01 016 0003 (2)	HN02 016 0003 (2)
	0,5 - 1,5 mm <sup>2</sup>	20 - 16	2000	HN01 016 0002 (1)	HN02 016 0002 (1)	HN01 016 0002 (2)	HN02 016 0002 (2)
	Standard 1,5 - 2,5 mm <sup>2</sup>	16 - 14	2000	HN01 016 0005 (1)	HN02 016 0005 (1)	HN01 016 0005 (2)	HN02 016 0005 (2)
	Hochstrom 1,5 - 2,5 mm <sup>2</sup>	16 - 14	2000	HN01 016 0015 (1)	HN02 016 0015 (1)		
	1,5 - 2,5 mm <sup>2</sup>	16 - 14	2000	HN01 016 0016 (1)	HN02 016 0016 (1)		
Kontaktzuführung links <i>Contact feeding left hand side</i>	0,14 - 0,5 mm <sup>2</sup>	26 - 20	2000	TN01 016 0003 (1)	TN02 016 0003 (1)	TN01 016 0003 (2)	TN02 016 0003 (2)
	0,5 - 1,5 mm <sup>2</sup>	20 - 16	2000	TN01 016 0002 (1)	TN02 016 0002 (1)	TN01 016 0002 (2)	TN02 016 0002 (2)
	Standard 1,5 - 2,5 mm <sup>2</sup>	16 - 14	2000	TN01 016 0005 (1)	TN02 016 0005 (1)	TN01 016 0005 (2)	TN02 016 0005 (2)
	Hochstrom 0,5 - 1,5 mm <sup>2</sup>	20 - 16	2000	TN01 016 0015 (1)	TN02 016 0015 (1)		
	1,5 - 2,5 mm <sup>2</sup>	18 - 14	2000	TN01 016 0016 (1)	TN02 016 0016 (1)		
Gedrehte Crimpkontakte / <i>Turned crimp contacts</i>							
Einzelkontakt <i>Single contact</i>	0,14 - 0,37 mm <sup>2</sup>	26 - 22	100	VN01 016 0024 (1)C	VN02 016 0024 (1)C	VN01 016 0024 (2)C	VN02 016 0024 (2)C
	0,5 mm <sup>2</sup>	20	100	VN01 016 0025 (1)C	VN02 016 0025 (1)C	VN01 016 0025 (2)C	VN02 016 0025 (2)C
	0,75 - 1,0 mm <sup>2</sup>	20 - 16	100	VN01 016 0026 (1)C	VN02 016 0026 (1)C	VN01 016 0026 (2)C	VN02 016 0026 (2)C
	1,5 mm <sup>2</sup>	16 - 15	100	VN01 016 0027 (1)C	VN02 016 0027 (1)C	VN01 016 0027 (2)C	VN02 016 0027 (2)C
	2,5 mm <sup>2</sup>	14	100	VN01 016 0028 (1)C	VN02 016 0028 (1)C	VN01 016 0028 (2)C	VN02 016 0028 (2)C
<b>Gestanzte Kontakte</b> <i>Stamped contacts</i>				<b>Gedrehte Kontakte</b> <i>Turned contacts</i>			
							
<b>Kurve / Curve</b>	<b>Kontakt / Contact</b>	<b>Querschnitt / Wire gauge</b>		<b>Kurve / Curve</b>	<b>Kontakt / Contact</b>	<b>Querschnitt / Wire gauge</b>	
a	Standard gestanzt	0,5 mm <sup>2</sup>		a	Standard gedreht	0,5 mm <sup>2</sup>	
b	Standard gestanzt	1,5 mm <sup>2</sup>		b	Standard gedreht	1,5 mm <sup>2</sup>	
c		2,5 mm <sup>2</sup>		c		2,5 mm <sup>2</sup>	
d	Hochstrom gestanzt	1,5 mm <sup>2</sup>					
e	Hochstrom gestanzt	2,5 mm <sup>2</sup>					

<sup>1)</sup> Erläuterung der Bestell-Nr. für die Kontakte siehe Seite 4  
<sup>1)</sup> Explanation of the Part No. for contacts see page 4

Abisolierlängen siehe S. 198  
Stripping length see p. 198

Modifizierte Kontaktanordnung für Bemessungsspannungen von 400 V

Modified contact arrangement for rated voltages of 400 V

- = Arbeitskontakt  
full load contact
- = Leerstelle  
unoccupied

(15) → 7 + ⊕

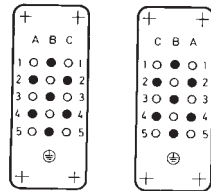

Buchseinsatz Female insert      Stifteinsatz Male insert

(25) → 11 + ⊕

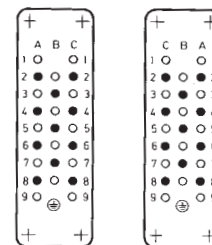

Buchseinsatz Female insert      Stifteinsatz Male insert

(40) → 20 + ⊕

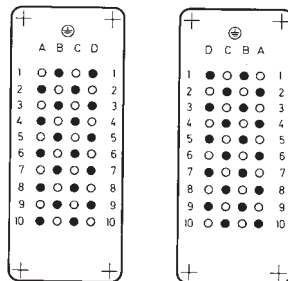

Buchseinsatz Female insert      Stifteinsatz Male insert

(64) → 32 + ⊕

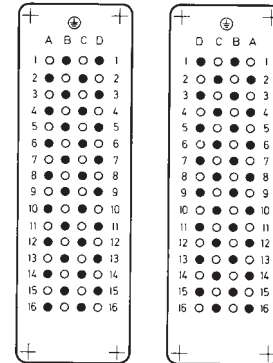

Buchseinsatz Female insert      Stifteinsatz Male insert

Lösen der Kontakte <sup>1)</sup>

Removal of contacts <sup>1)</sup>

Demontage von Steckseite / front releas



- Prinzip:
- gestanzte Stifkontakte  
Stamped male contacts
  - gedrehte Kontakte  
Turned contacts

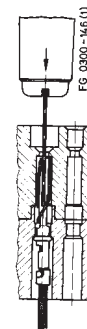

- gestanzte Buchsenkontakte  
Stamped female contacts

Werkzeuge / Tools <sup>1)</sup>



Bezeichnung / Description	für Leiterquerschnitt for wire gauge	Bestell Nr. / Part No.		Werkzeuge / Tools
		Kontaktaufnahme / Contact locator	Crimpbacken / Crimping dies	
Lösewerkzeug für Kontakte Removal tool for contacts	—	—	—	FG 0300 146 1
Service Crimpzange Service crimping tool	0,14 - 0,5 mm <sup>2</sup> 0,5 - 1,5 mm <sup>2</sup>	—	—	TA 0100 146
Crimpzange für Einzelkontakte Crimping tool for single contacts	0,14 - 0,5 mm <sup>2</sup> 0,5 - 1,5 mm <sup>2</sup> 1,5 - 2,5 mm <sup>2</sup>	TA 0001 146 000 1 TA 0002 146 000 1 TA 0007 146 000 3	TA 0000 202 TA 0000 163 TA 0000 141	TA 0000 TA 0500

<sup>1)</sup> Weitere Informationen siehe Katalog „Werkzeuge“ / Further information see catalogue „Tools“

# C 146 DD

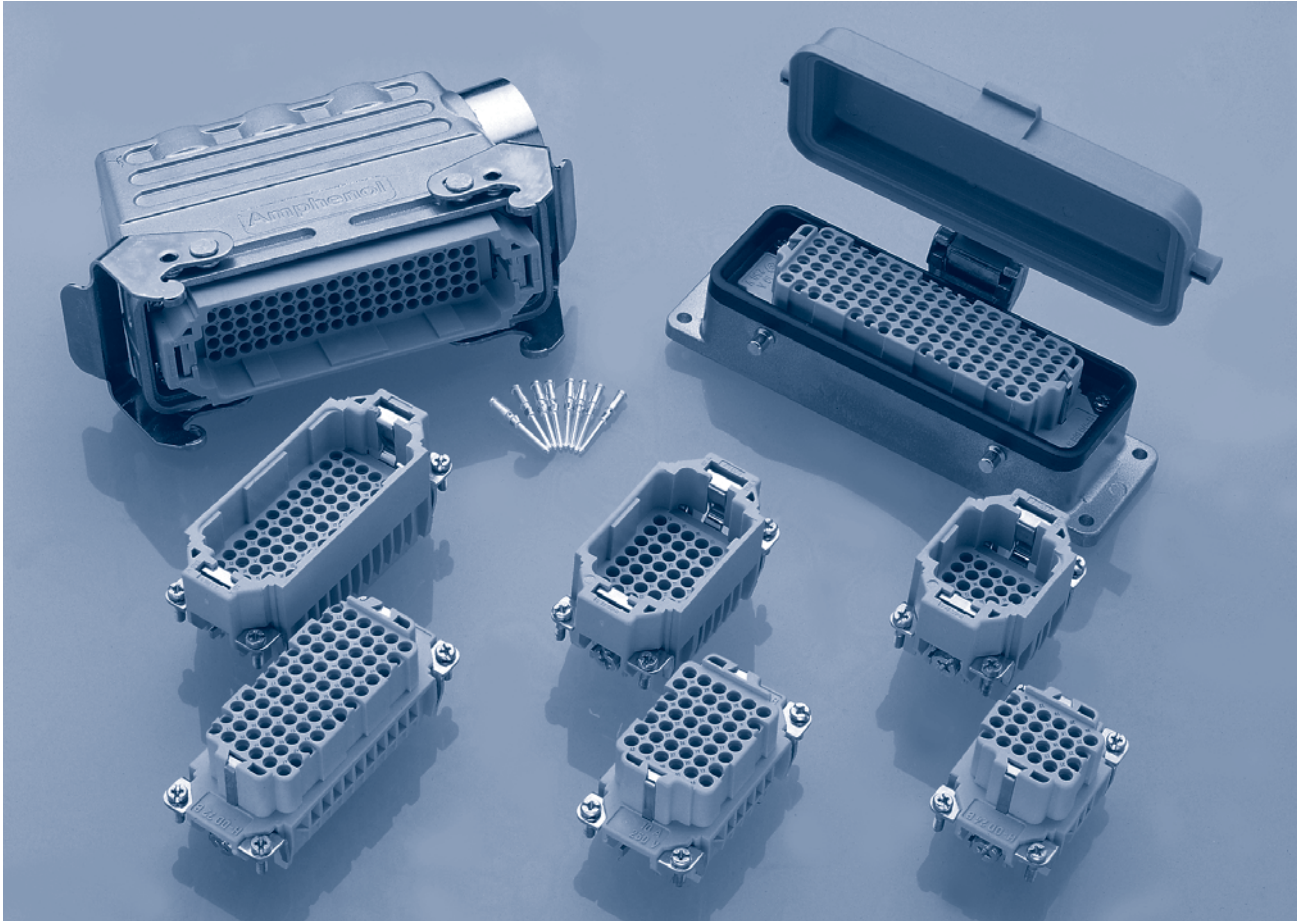
DD



<b>Hauptmerkmale</b>		<b>Main characteristics</b>	
<ul style="list-style-type: none"> <li>• Bemessungsspannung 250 V</li> <li>• Bemessungsstrom 8 A ... 9 A</li> <li>• Anschlussart: crimpen</li> <li>• Polzahl: 24, 42, 72, 108</li> </ul>		<ul style="list-style-type: none"> <li>• Rated voltage 250 V</li> <li>• Rated current 8 A ... 9 A</li> <li>• Termination: crimp</li> <li>• Number of contacts: 24, 42, 72, 108</li> </ul>	
<b>Zulassungen / Approvals</b>	<b>Prüfstelle / Testhouse</b>	<b>Kennwerte / Characteristics</b>	<b>Zulassungs-Nummer / Approval-No.</b>
SEV		250 V, 10 A	
UL		600 V, 8,5 A	E 63093
CSA		600 V, 20 A	LR 700721
<p>Zulassungen beziehen sich im allgemeinen auf repräsentative Ausführungen der Steckverbinderserie. Prüfumfang und Prüfvorschrift auf Anfrage.</p>		<p><i>In general approvals refer to representative versions of the connector series. Extent and specification of tests upon request.</i></p>	

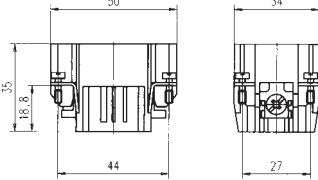
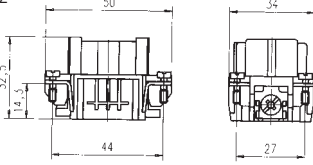
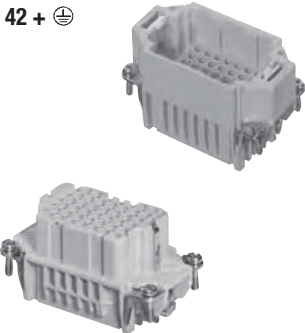
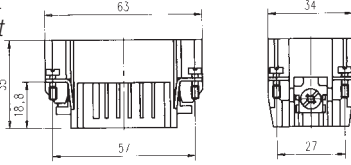
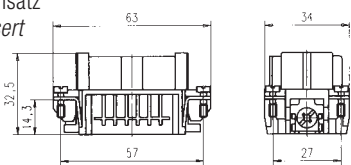
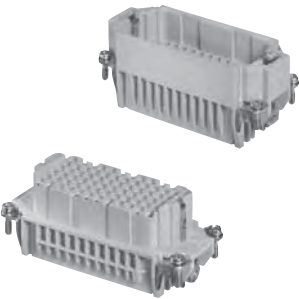
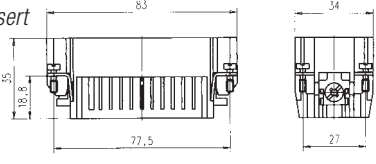
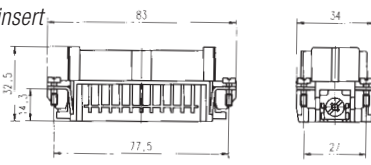
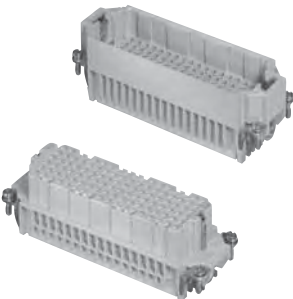
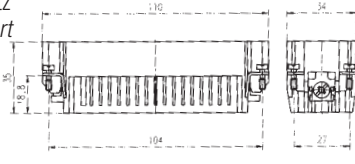
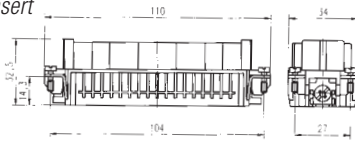

**C 146 DD****250 V~ 8 / 9 A****Steckverbinder  
Connectors****für gedrehte Kontakte  
for turned contacts****Gehäuse siehe Seite 126-153  
Housings see page 126-153**

Bezeichnung - Abbildung Description - Figure	Maßzeichnung Drawing	Bestell Nr. / Part No.	
		Stifteinsatz / Male insert	Buchseinsatz / Female insert
Kontakteinsatz Contact insert <b>24 + ⊕</b> 	Stifteinsatz Male insert  Buchseinsatz Female insert 	C146 10A024 000 9	C146 10B024 000 9
Kontakteinsatz Contact insert <b>42 + ⊕</b> 	Stifteinsatz Male insert  Buchseinsatz Female insert 	C146 10A042 000 9	C146 10B042 000 9
Kontakteinsatz Contact insert <b>72 + ⊕</b> 	Stifteinsatz Male insert  Buchseinsatz Female insert 	C146 10A072 000 9	C146 10B072 000 9
Kontakteinsatz Contact insert <b>108 + ⊕</b> 	Stifteinsatz Male insert  Buchseinsatz Female insert 	C146 10A108 000 9	C146 10B108 000 9

# C 146 DD

Steckverbinder  
Connectors

Crimpkontakte  
Crimp contacts

Gedrehte 1,6 mm Kontakte  
Turned 1,6 mm contacts

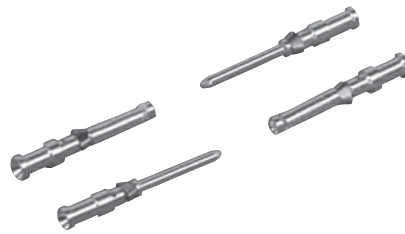

DD

Bezeichnung - Abbildung Description - Figure	Maßzeichnung Drawing	Bestell Nr. / Part No.	
		Stifteinsatz / Male insert	Buchseinsatz / Female insert
Kontakteinsatz Contact insert <b>216 +</b> 	Stifteinsatz Male insert   Buchseinsatz Female insert 	C146 10A108 000 9 + C146 10A108 005 9	C146 10B108 000 9 + C146 10B108 005 9

Lieferform Supplied as	für Leiter- querschnitt for wire gauge	AWG	Stück- zahl Pieces	Bestell Nr. <sup>1)</sup> Stiftkontakt Male contact	Part No. <sup>1)</sup> Buchsenkontakt Female contact	Bestell Nr. <sup>1)</sup> Stiftkontakt Male contact	Part No. <sup>1)</sup> Buchsenkontakt Female contact
				versilbert / silver plating		vergoldet / gold plating	
Einzeltakt Single contact	0,14 - 0,37 mm <sup>2</sup>	26 - 22	100	VN01 016 0024 (1)C	VN02 016 0024 (1)C	VN01 016 0024 (2)C	VN02 016 0024 (2)C
	0,5 mm <sup>2</sup>	20	100	VN01 016 0025 (1)C	VN02 016 0025 (1)C	VN01 016 0025 (2)C	VN02 016 0025 (2)C
	0,75 - 1,0 mm <sup>2</sup>	20 - 16	100	VN01 016 0026 (1)C	VN02 016 0026 (1)C	VN01 016 0026 (2)C	VN02 016 0026 (2)C
	1,5 mm <sup>2</sup>	16 - 15	100	VN01 016 0027 (1)C	VN02 016 0027 (1)C	VN01 016 0027 (2)C	VN02 016 0027 (2)C
	2,5 mm <sup>2</sup>	14	100	VN01 016 0028 (1)C	VN02 016 0028 (1)C	VN01 016 0028 (2)C	VN02 016 0028 (2)C

Montageanleitung, Steckbild / Assembly instruction, pin layout

Stifteinsatz  
Male insert

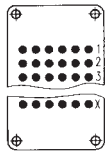

Buchseinsatz  
Female insert

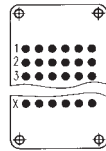

X = 4 ( 24 pol. )  
7 ( 42 pol. )  
12 ( 72 pol. )  
18 ( 108 pol. )

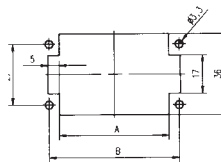

Pol	A	B
24	35	44
42	48	57
72	69	77,5
108	95	104

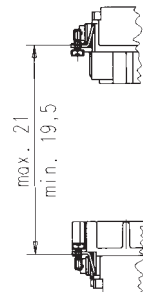

Derating Kurven / Derating curves

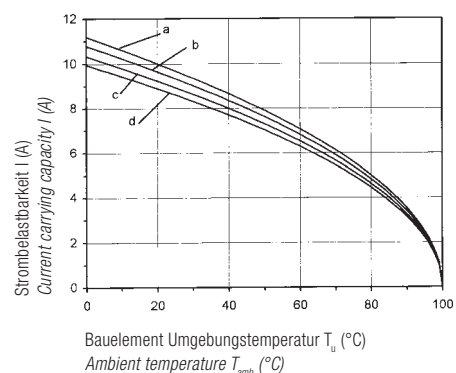
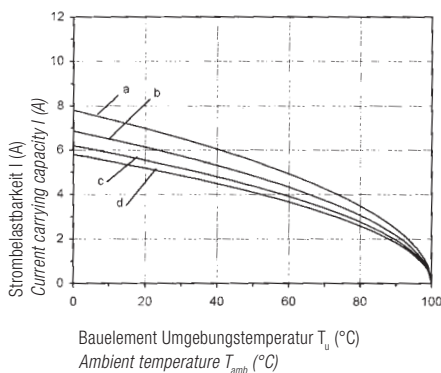

Kurve / Curves	Polzahl / Contacts	Querschnitt / Wire gauge	Kurve / Curves	Polzahl / Contacts	Querschnitt / Wire gauge
a	24	0,75 mm <sup>2</sup>	a	24	1,5 mm <sup>2</sup>
b	42	0,75 mm <sup>2</sup>	b	42	1,5 mm <sup>2</sup>
c	72	0,75 mm <sup>2</sup>	c	72	1,5 mm <sup>2</sup>
d	108	0,75 mm <sup>2</sup>	d	108	1,5 mm <sup>2</sup>

<sup>1)</sup> Erläuterung der Bestell-Nr. für die Kontakte siehe Seite 4  
<sup>1)</sup> Explanation of the Part No. for contacts see page 4

Abisolierlängen siehe S. 198  
Stripping length see p. 198





Allgemeine Kennwerte	General Characteristics	Norm / Standard	Wert / Value			
Polzahl	Number of contacts		24 + ⊕	42 + ⊕	72 + ⊕	108 + ⊕
Anschluss technik	Termination technique		crimpen / crimp			
Anschlussquerschnitt	Wire gauge		0,14 mm <sup>2</sup> - 2,5 mm <sup>2</sup>			
Brennbarkeit	Flammability	UL 94	V-0			
Elektrische Kennwerte	Electrical Characteristics					
Bemessungsspannung	Rated voltage	IEC 60664-1	250 V (600 V UL / CSA)			
Verschmutzungsgrad	Pollution degree	IEC 60664-1	2 (3 in gestecktem + verriegeltem Zustand) 2 (3 mated and locked)			
Überspannungskategorie	Installation (overvoltage) category	IEC 60664-1	III			
Isolierstoffgruppe	Material group	IEC 60664-1	III b			
Bemessungs-Stoßspannung	Rated impulse withstand voltage	IEC 60664-1	4 kV			
Spannungsfestigkeit	Voltage proof	IEC 60512-2; Test 4 a	2 kV			
Strombelastbarkeit	Current carrying capacity	IEC 60512-3; Test 5 b	siehe Derating Kurven / see derating curves			
Bemessungsstrom $T_u = 40\text{ °C}$	Rated current $T_{amb} = 40\text{ °C}$		9 A	9 A	8 A	8 A
Durchgangswiderstand	Contact resistance	IEC 60512-2; Test 2 a	≤ 5 m Ω			
Isolationswiderstand	Insulation resistance	IEC 60512-2; Test 3 a	≥ 10 <sup>12</sup> Ω <sup>1)</sup>			
Luftstrecke	Clearance	VDE 0627	> 2,5 mm			
Kriechstrecke	Creepage	VDE 0627	> 4 mm			
Klimatische Kennwerte	Climatical Characteristics					
Prüfklasse	Climatic category	IEC 60068-1	40 / 100 / 21			
Obere Grenztemperatur	Upper temperature	IEC 60512-6; Test 11 i	+ 100 °C / 1000 h			
Untere Grenztemperatur	Lower temperature	IEC 60512-6; Test 11 i	- 40 °C			
Mechanische Kennwerte	Mechanical Characteristics					
Gewicht Stifteinsatz	Weight pin insert		44 g	50 g	63 g	86 g
IP-Schutzart Stifteinsatz	IP-degree of protection pin insert	IEC 60529	ungesteckt/unmated IP00		gesteckt/mated IP20	
IP-Schutzart Buchseneinsatz	IP-degree of protection socket insert	IEC 60529	ungesteckt/unmated IP20		gesteckt/mated IP20	
Gewicht Buchseneinsatz	Weight socket insert		41 g	50 g	67 g	88 g
Mechanische Lebensdauer	Mechanical operation	IEC 60512-5; Test 9 a	≥ 500 Steckzyklen / mating cycles			
Werkstoffe	Materials					
Kontakteinsatz	Insert		PBT			
Kontakte	Contacts		CuZn (Messing / brass)			
Kontaktoberfläche	Contact plating		Ag			
Farbe	Colour		grau / grey			

<sup>1)</sup> Bei Beanspruchung > 10<sup>10</sup> Ω / Under operating conditions > 10<sup>10</sup> Ω

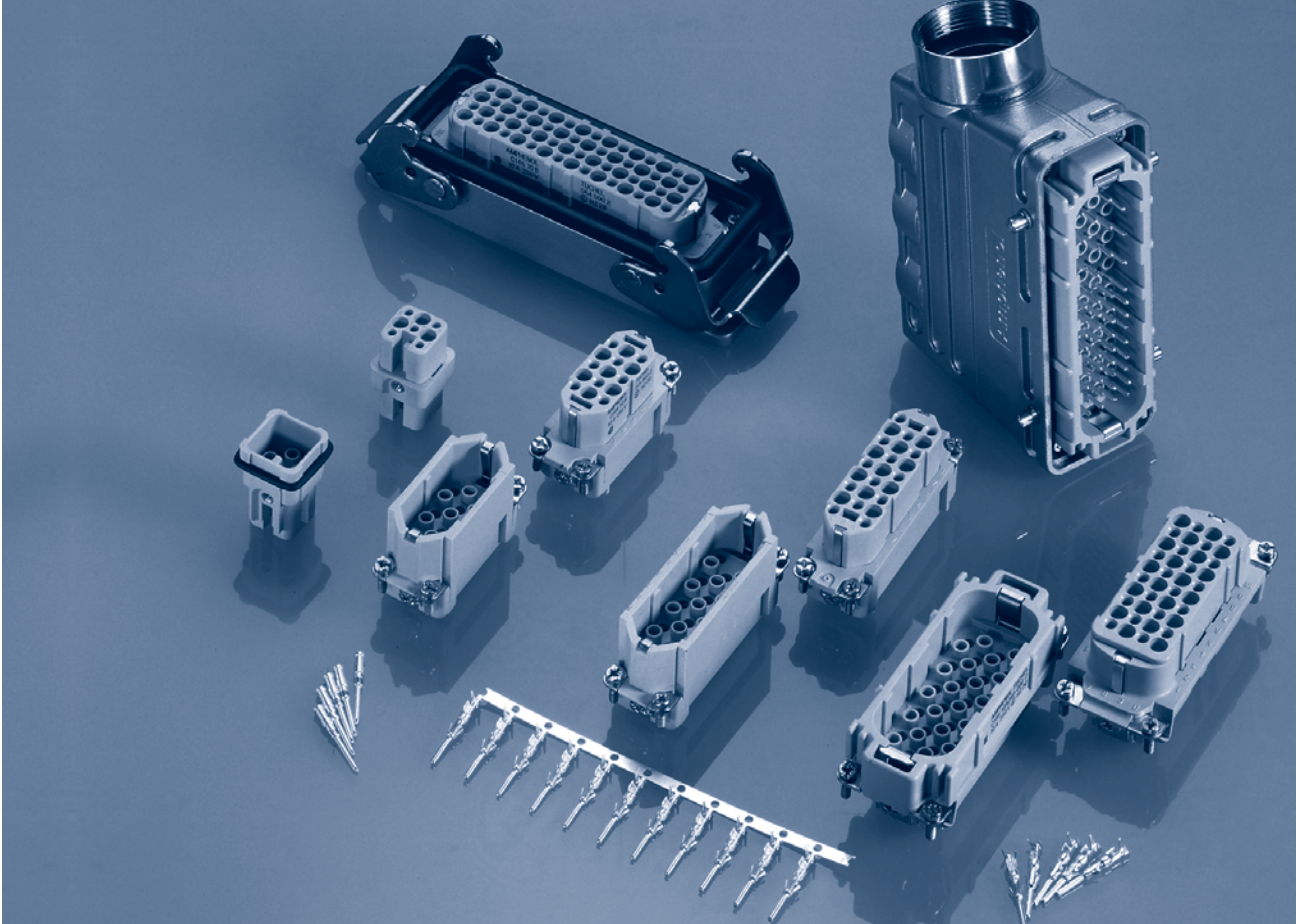

# C 146 E





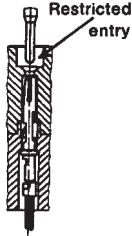
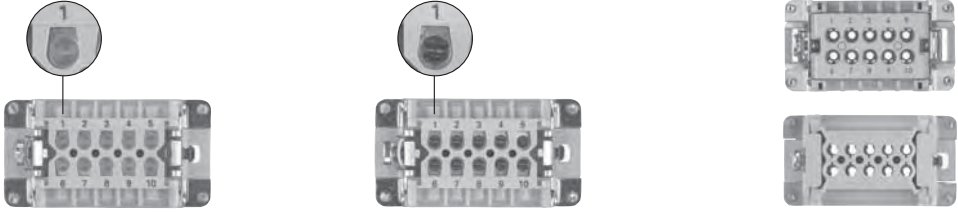
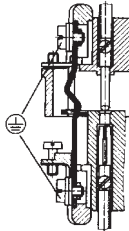

E

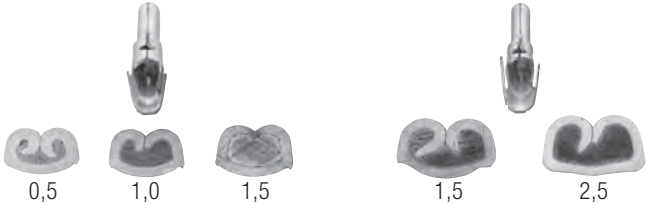

Hauptmerkmale		Main characteristics	
<ul style="list-style-type: none"> <li>• Bemessungsspannung 400 V</li> <li>• Bemessungsstrom 16 A ... 22 A</li> <li>• Anschlussart: schrauben oder crimpen</li> <li>• Kontaktdurchmesser 2,5 mm</li> <li>• Polzahl: 6, 10, 16, 24, 48</li> </ul>		<ul style="list-style-type: none"> <li>• Rated voltage 400 V</li> <li>• Rated current 16 A ... 22 A</li> <li>• Termination: screw or crimp</li> <li>• Contact diameter 2,5 mm</li> <li>• Numbers of contacts: 6, 10, 16, 24, 48</li> </ul>	
Zulassungen / Approvals Prüfstelle / Testhouse		Kennwerte / Characteristics	Zulassungs-Nummer / Approval-No.
SEV		400 V, 16 A	
UL		600 V, 10 A	E 63093
CSA		600 V, 15 A	48932
DB		400 V, 16 A	BN 74 018
<p>Zulassungen beziehen sich im allgemeinen auf repräsentative Ausführungen der Steckverbinderserie. Prüfumfang und Prüfvorschrift auf Anfrage.</p>		<p>In general approvals refer to representative versions of the connector series. Extent and specification of tests upon request.</p>	

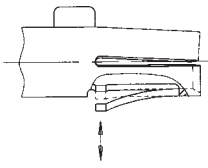
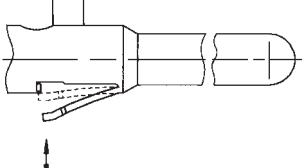

<p>Allgemeine Hinweise</p>  <p>General information</p>	<ul style="list-style-type: none"> <li>• Kontakteinsätze ohne Crimpkontakte (bei Kontakteinsatz mit Crimpanschluss).</li> <li>• Steckverbinder der Serie C 146 E dürfen unter Spannung, jedoch nicht unter Strom betätigt werden. Werden die Steckverbinder unter Last gesteckt und getrennt, ist der Strom auf 10 % des Bemessungsstromes zu begrenzen.</li> <li>• Crimpwerkzeuge und Verarbeitungshinweise siehe separater Katalog „Werkzeuge“.</li> <li>• Für die Einsätze der Serie C 146 E können sowohl niedrige, wie auch hohe Gehäusebauformen verwendet werden.</li> <li>• Bei Verwendung von Aderendhülsen, sind Schraubanschlüsse ohne Drahtschutz zu bevorzugen.</li> </ul> <ul style="list-style-type: none"> <li>• <i>Contact inserts without crimp contacts.</i></li> <li>• <i>Connectors series C146 E may be engaged or disengaged when live but without electrical load. If these connectors are mated or unmated under load, the load shall be reduced to 10 % of the rated current.</i></li> <li>• <i>Crimping tools and processing instructions see separate catalogue „Tools“.</i></li> <li>• <i>Low and high profile housings are usable.</i></li> <li>• <i>If wire ferrule are used, screw terminals without wire protection are preferred.</i></li> </ul>
<p>Nicht genormte Steckverbinder, aber:</p> <p>No standard for this series, but:</p>	<p>Steck- und austauschbar mit Fremdfabrikaten</p> <p>Gehäuse nach DIN EN 175 301 - 801</p> <p>a) Kontakteinsatz/Kontakteinsatz 6, 10, 16, 24 pol. b) Kontakteinsatz/Gehäuse 6, 10, 16, 24 pol.</p> <p><i>Interchangeable with other products</i></p> <p><i>Housings are designed according to DIN EN 175 301 - 801</i></p> <p>a) <i>contact insert to contact insert 6, 10, 16, 24 contacts</i> b) <i>contact insert to housing 6, 10, 16, 24 contacts</i></p>
<p>Hoher Schutz vor Fehlsteckungen</p> <p>High protection against mismatching</p>	<p>Buchsenkontakteinsatz mit trichterförmiger, verengter Stecköffnung. (Hohe Steck- und Kontaktsicherheit)</p> <p><i>Female inserts with funnel shaped contact entry avoids mismatching.</i></p> 
<p>Kontakteinsätze für Schraubanschluss, Schraubanschluss mit Drahtschutz und für Crimptechnik</p> <p>Contact inserts for screw termination, screw termination with wire protection and for crimp termination</p>	 <p>Schraubanschluss <i>Screw termination</i></p> <p>Schraubanschluss mit Drahtschutz <i>Screw termination with wire protection</i></p> <p>Crimpanschluss <i>Crimp termination</i></p>
<p>Voreilender Schutzkontakt</p> <p><i>First-to-mate last-to-break protective ground contact</i></p>	
<p>Große Gehäuseauswahl in 2 Bauhöhen (ab Seite 126)</p> <p>Large range of housings in 2 different heights (see page 126)</p>	

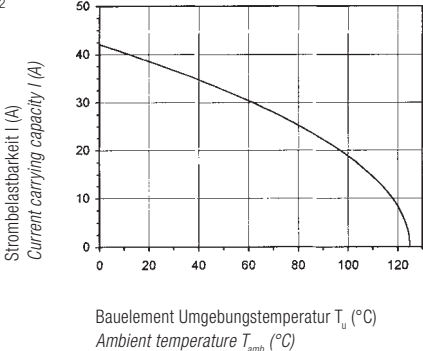
<p>Großer Crimpbereich Gasdichte Verbindung (Kaltverschweißung)</p> <p><i>Large range of wire gauges Gas-tight (coldwelding)</i></p>	<p>.N01 025 0001 (1) <sup>1)</sup>                      .N01 025 0010 (1) <sup>1)</sup></p>  <p>0,5      1,0      1,5                      1,5      2,5</p>		
<p>Gestanzte Crimpkontakte mit Isolierungshalterung um mechanische Beanspruchungen von der Crimpverbindung fernzuhalten</p> <p><i>Stamped crimp contacts with insulation crimp to absorb mechanical stress from the crimped connection</i></p>	 <p>Isolierungshalterung <i>Insulation grip</i></p>		
<p>Mechanischer Rasthakenanschlag bei Buchsen- und Stiftkontakt</p> <p><i>Mechanical retention spring stop on female and male contact</i></p>	<p>Buchsenkontakt <i>Female contact</i></p> 	<p>Stiftkontakt <i>Male contact</i></p> 	
<p>Kostengünstige, einfache Verarbeitung. Werkzeuge siehe Katalog „Werkzeuge“</p> <p><i>Economical and easy processing. Tools see catalogue „Tools“</i></p>	 <p>Einzel-Fertigung <i>Single production</i></p>	 <p>Kleinserie <i>Small series</i></p>	 <p>Serie <i>Series</i></p>
<p>Hohe Strombelastbarkeit (siehe Derating Kurven)</p> <p><i>High current carrying capacity (see derating curves)</i></p>	<p>Beispiel Einzelkontakt, Anschlussquerschnitt 2,5 mm<sup>2</sup></p> <p><i>Example single contact, wire gauge 2.5 mm<sup>2</sup></i></p>  <p>Strombelastbarkeit I (A) <i>Current carrying capacity I (A)</i></p> <p>Bauelement Umgebungstemperatur T<sub>u</sub> (°C) <i>Ambient temperature T<sub>amb</sub> (°C)</i></p>		

<sup>1)</sup> Erläuterung der Bestell-Nr. für die Kontakte siehe Seite 4 / *Explanation of the Part No. for contacts see page 4*



Technische Daten  
Characteristics

**Kontakteinsätze / Connector inserts**

Allgemeine Kennwerte		General Characteristics	Norm / Standard					Wert / Value				
Polzahl	Number of contacts							6 +⊕	10 +⊕	16 +⊕	24 +⊕	48 +⊕
Anschlussstechnik	Termination technique							crimpen / schrauben <i>crimp / screw</i>				
Anschlussquerschnitt: crimpen, schrauben	Wire gauge: crimp, screw							0,5 - 4 mm <sup>2</sup> 0,25 - 2,5 mm <sup>2</sup>				
Brennbarkeit	Flammability	UL 94						V-0				
Elektrische Kennwerte		Electrical Characteristics										
Bemessungsspannung	Rated voltage	IEC 60664-1						400 V (600 V UL / CSA <sup>2)</sup> )				
Verschmutzungsgrad	Pollution degree	IEC 60664-1						3				
Isolierstoffgruppe	Material group	IEC 60664-1						III b				
Überspannungskategorie	Installation (overvoltage) category	IEC 60664-1						III				
Bemessungs-Stoßspannung	Rated impulse withstand voltage	IEC 60664-1						6,0 kV				
Spannungsfestigkeit	Voltage proof	IEC 60512-2; Test 4 a						2,8 kV				
Strombelastbarkeit	Current carrying capacity	IEC 60512-2; Test 5 b						siehe Derating Kurven / see derating curves				
Bemessungsstrom (T <sub>u</sub> = 40 °C)	Rated current (T <sub>amb</sub> = 40 °C)							22 A	19 A	19 A	18 A	18 A
Durchgangswiderstand	Contact resistance	IEC 60512-2; Test 2 a						< 5 mΩ				
Isolationswiderstand	Insulation resistance	IEC 60512-2; Test 2 a						≥ 10 <sup>12</sup> Ω <sup>1)</sup>				
Luftstrecke	Clearance	DIN VDE 0627						> 4,0 mm				
Kriechstrecke	Creepage	DIN VDE 0627						> 6,3 mm				
Klimatische Kennwerte		Climatical Characteristics										
Prüfklasse	Climatic category	IEC 60068-1						40 / 125 / 21				
Obere Grenztemperatur	Upper temperature	IEC 60512-6; Test 11 i						+ 125 °C / 1000 h				
Untere Grenztemperatur	Lower temperature	IEC 60512-6; Test 11 i						- 40 °C				
Mechanische Kennwerte		Mechanical Characteristics										
Gesamt Steck- und Ziehkraft crimpen schrauben	Insertion and withdrawal forces: crimp screw	IEC 60512-7; Test 13 b						10-20 N	30-40 N	45-60 N	70-100 N	140-200 N
<sup>3)</sup> IP-Schutzart Stifteinsatz	IP-degree of protection pin insert	IEC 60529						ungesteckt/unmated IP00		gesteckt/mated IP20		
<sup>3)</sup> IP-Schutzart Buchseneinsatz	IP-degree of protection socket insert	IEC 60529						ungesteckt/unmated IP20		gesteckt/mated IP20		
Gewicht: Stifteinsatz crimp (gestanzte Kontakte) Buchseneinsatz crimp (gest. Kontakte) Stifteinsatz schraub Buchseneinsatz schraub	Weight: male insert crimp (f. stamped contacts) female insert crimp (f. stamped contacts) male insert screw female insert screw							33 g	39 g	45 g	55 g	110 g
								33 g	39 g	49 g	62 g	124 g
								43 g	57 g	78 g	105 g	210 g
								43 g	57 g	78 g	106 g	212 g
Mechanische Lebensdauer	Mechanical operation	IEC 60512-5; Test 9 a						> 500 Steckzyklen / mating cycles				
Werkstoffe		Materials										
Kontakteinsatz	Insert							PC GV (Polycarbonat)				
Schraubkontakte	Screw contacts							CuZn (Messing/brass)				
Kontaktoberfläche	Contact plating							Ag (silber/silver)				
Farbe	Colour							grau / grey				

<sup>1)</sup> Bei Beanspruchung > 10<sup>10</sup> Ω / Under operating conditions 10<sup>10</sup> Ω    <sup>2)</sup> Hinweisschild für CSA-Anwendungen siehe Seite 176 / Label for CSA application see page 176

<sup>3)</sup> IP-Schutzart im Anschlussbereich der Schraubausführung IP 10 / IP-degree of protection on termination side of screw version IP 10

**Technische Daten**  
*Characteristics*
**Gestanzte Crimpkontakte / Stamped crimp contacts**

<b>Elektrische Kennwerte</b>	<b>Electrical Characteristics</b>		
Durchgangswiderstand	Contact resistance	IEC 60512-2; Test 2 a	< 5 m Ω
Kapazität Kontakt-Kontakt	Capacity contact-contact	IEC 60512-9; Test 22 a	≥ 2 p F
Kapazität Kontakt-Gehäuse	Capacity contact-housing	IEC 60512-9; Test 22 a	≥ 3,2 p F
<b>Mechanische Kennwerte</b>	<b>Mechanical Characteristics</b>		
Mechanische Lebensdauer	Mechanical operation	IEC 60512-5; Test 9 a	≥ 500 Steckzyklen / mating cycles
<b>Werkstoffe</b>	<b>Materials</b>		
Stiftkontakt	Male contact		CuZn (Messing / brass)
Buchsenkontakt	Female contact		CuSn (Zinnbronze / Tin bronze)
Kontaktoberfläche	Contact plating		Ag

**Gedrehte Crimpkontakte / Turned crimp contacts**

<b>Elektrische Kennwerte</b>	<b>Electrical Characteristics</b>		
Durchgangswiderstand	Contact resistance	IEC 60512-2	≤ 5 m Ω
<b>Klimatische Kennwerte</b>	<b>Climatical Characteristics</b>		
Obere Grenztemperatur	Upper temperature	IEC 60512-6	+ 100 °C
Untere Grenztemperatur	Lower temperature	IEC 60512-6	- 40 °C
<b>Mechanische Kennwerte</b>	<b>Mechanical Characteristics</b>		
Mechanische Lebensdauer	Mechanical operation	IEC 60512-5; Test 9 a	≥ 500 Steckzyklen / mating cycles
<b>Werkstoffe</b>	<b>Materials</b>		
Stiftkontakt	Male contact		CuZn (Messing / brass)
Buchsenkontakt	Female contact		CuZn (Messing / brass)
Kontaktoberfläche	Contact plating		Ag

C 146 E

6 + 

Steckverbinder  
Connectors







400 V~ Kontakteinsatz für gestanzte Kontakte /  
Contact insert for stamped contacts

500 V~ Kontakteinsatz für Schraubanschluss und für gedrehte Kontakte /  
Contact insert for screw termination and for turned contacts

16 / 22 A

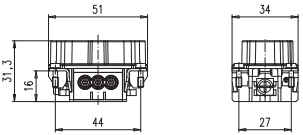
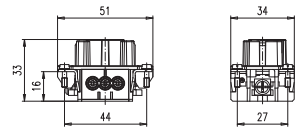
Gehäuse siehe Seite 126-129

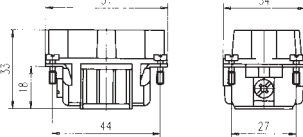
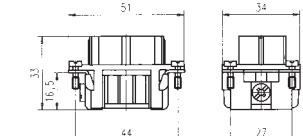
Housings see page 126-129

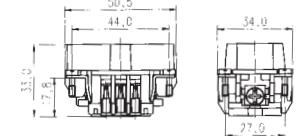
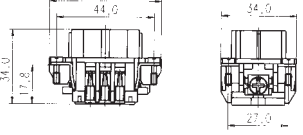
Bezeichnung - Abbildung Description - Figure	Maßzeichnung Drawing	Bestell Nr. / Part No.	
		Stifteinsatz / Male insert	Buchseneinsatz / Female insert
Kontakteinsatz Schraubanschluss Contact insert screw termination    	Stifteinsatz Male insert    Buchseneinsatz Female insert  	C146 10A006 002 1   C146 10A006 102 1 (mit Drahtschutz with wire protection)	C146 10B006 002 1   C146 10B006 102 1 (mit Drahtschutz with wire protection)
Kontakteinsatz für gestanzte Kontakte Contact insert for stamped contacts    	Stifteinsatz Male insert    Buchseneinsatz Female insert  	C146 10A006 000 1	C146 10B006 000 1
Kontakteinsatz für gedrehte Kontakte Contact insert for turned contacts    	Stifteinsatz Male insert    Buchseneinsatz Female insert  	C146 10A006 500 1	C146 10B006 500 1



C 146 E

6 + 

**Crimpkontakte**  
**Crimp contacts**

Gestanzte Einzelkontakte / Stamped single contacts

Gestanzte Bandkontakte für Crimpzangen / Stamped contacts on reel for hand crimping tools

Gestanzte Bandkontakte für Crimpmaschinen / Stamped contacts on reel for crimp machines



Gedrehte Einzelkontakte / Turned single contacts



200 / 100 Stück

200 / 100 pcs



2000 Stück  
(Zuführung links oder rechts)

2000 pcs  
(feeding left or right hand side)

Lieferform <i>Supplied as</i>	für Leiter- querschnitt <i>for wire gauge</i>	AWG	Stück- zahl <i>Pieces</i>	Bestell Nr. <sup>1)</sup> Stiftkontakt <i>Male contact</i>	Part No. <sup>1)</sup> Buchsenkontakt <i>Female contact</i>	Bestell Nr. <sup>1)</sup> Stiftkontakt <i>Male contact</i>	Part No. <sup>1)</sup> Buchsenkontakt <i>Female contact</i>
Gestanzte Einzelkontakte / <i>Stamped single contacts</i>				versilbert / <i>silver plating</i>		vergoldet / <i>gold plating</i>	
	0,5 - 1,5 mm <sup>2</sup>	20 - 16	100	VN01 025 0001 (101)	VN02 025 0001 (101)	VN01 025 0001 (102)	VN02 025 0001 (102)
	1,5 - 2,5 mm <sup>2</sup>	16 - 14	100	VN01 025 0010 (101)	VN02 025 0010 (101)	VN01 025 0010 (102)	VN02 025 0010 (102)
Gestanzte Bandkontakte für Crimpzangen / <i>Stamped Contacts on reel for hand crimp tools</i>							
	0,5 - 1,5 mm <sup>2</sup>	20 - 16	200	ZN01 025 0001 (1)	ZN02 025 0001 (1)	ZN01 025 0001 (2)	ZN02 025 0001 (2)
	1,5 - 2,5 mm <sup>2</sup>	16 - 14	100	ZN01 025 0010 (1)	ZN02 025 0010 (1)	ZN01 025 0010 (2)	ZN02 025 0010 (2)
Gestanzte Bandkontakte für Crimpmaschinen / <i>Stamped contacts on reel for crimp machines</i>							
Kontaktzuführung rechts <i>Contact feeding right hand side</i>	0,5 - 1,5 mm <sup>2</sup>	20 - 16	2000	HN01 025 0001 (1)	HN02 025 0001 (1)		
	1,5 - 2,5 mm <sup>2</sup>	16 - 14	2000	HN01 025 0010 (1)	HN02 025 0010 (1)		
Kontaktzuführung links <i>Contact feeding left hand side</i>	0,5 - 1,5 mm <sup>2</sup>	20 - 16	2000	TN01 025 0001 (1)	TN02 025 0001 (1)		
	1,5 - 2,5 mm <sup>2</sup>	16 - 14	2000	TN01 025 0010 (1)	TN02 025 0010 (1)		
Gedrehte Crimpkontakte / <i>Turned crimp contacts</i>							
Einzelkontakt <i>Single contact</i>	0,5 mm <sup>2</sup>	20	100	VN01 025 0035 (1)C	VN02 025 0035 (1)C	VN01 025 0035 (2)C	VN02 025 0035 (2)C
	0,75 - 1,0 mm <sup>2</sup>	18	100	VN01 025 0036 (1)C	VN02 025 0036 (1)C	VN01 025 0036 (2)C	VN02 025 0036 (2)C
	1,5 mm <sup>2</sup>	16	100	VN01 025 0037 (1)C	VN02 025 0037 (1)C	VN01 025 0037 (2)C	VN02 025 0037 (2)C
	2,5 mm <sup>2</sup>	14	100	VN01 025 0038 (1)C	VN02 025 0038 (1)C	VN01 025 0038 (2)C	VN02 025 0038 (2)C
	4,0 mm <sup>2</sup>	12	100	VN01 025 0039 (1)C	VN02 025 0039 (1)C	VN01 025 0039 (2)C	VN02 025 0039 (2)C
Montageanleitung, Steckbild / <i>Assembly instruction, pin layout</i>							

Stifteinsatz  
*Male insert*

Buchseinsatz  
*Female insert*

Montageausschnitt (Kontaktträger)  
*Panel cut out (insert)*

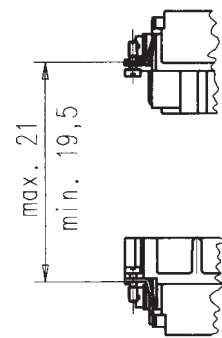
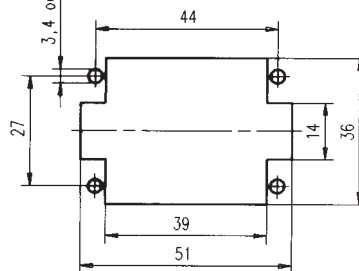
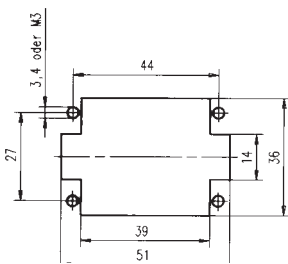

Derating Kurven / *Derating curves*

**Gestanzte Kontakte**  
**Stamped contacts**

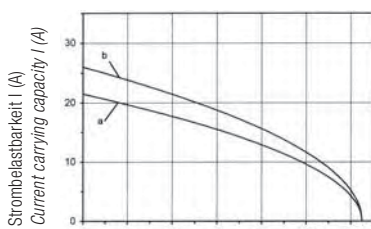

Bauelement Umgebungstemperatur T<sub>u</sub> (°C)  
Ambient temperature T<sub>amb</sub> (°C)

**Gedrehte Kontakte**  
**Turned contacts**

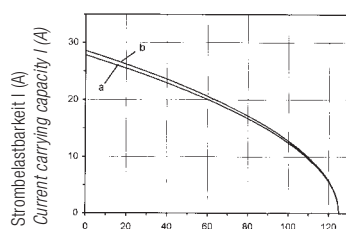

Bauelement Umgebungstemperatur T<sub>u</sub> (°C)  
Ambient temperature T<sub>amb</sub> (°C)

**Schraubanschluss**  
**Screw termination**

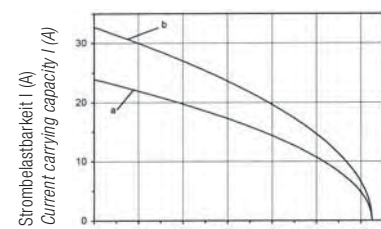

Bauelement Umgebungstemperatur T<sub>u</sub> (°C)  
Ambient temperature T<sub>amb</sub> (°C)

**Kurve a:** 1,5 mm<sup>2</sup> Leiterquerschnitt  
**Curve a:** 1,5 mm<sup>2</sup> wire gauge

**Kurve b:** 2,5 mm<sup>2</sup> Leiterquerschnitt  
**Curve b:** 2,5 mm<sup>2</sup> wire gauge

<sup>1)</sup> Erläuterung der Bestell-Nr. für die Kontakte siehe Seite 4  
*Explanation of the Part No. for contacts see page 4*

Abisolierlängen siehe S. 198  
*Stripping length see p. 198*

C 146 E

10 + 

Steckverbinder  
Connectors







400 V~ Kontakteinsatz für gestanzte Kontakte /  
Contact insert for stamped contacts

500 V~ Kontakteinsatz für Schraubanschluss und für gedrehte Kontakte /  
Contact insert for screw termination and for turned contacts

16 / 22 A

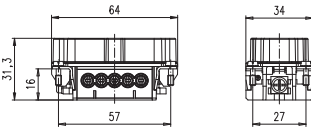
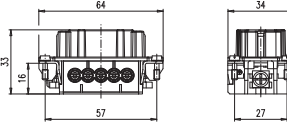
Gehäuse siehe Seite 130-137

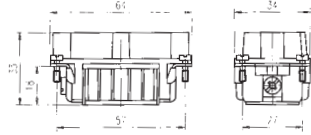
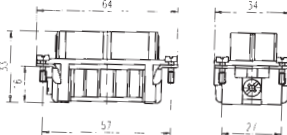
Housings see page 130-137

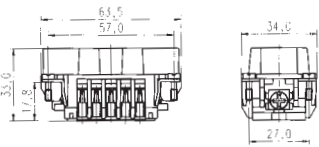
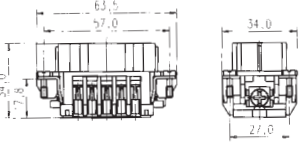
Bezeichnung - Abbildung Description - Figure	Maßzeichnung Drawing	Bestell Nr. / Part No.	
		Stifteinsatz / Male insert	Buchseinsatz / Female insert
Kontakteinsatz Schraubanschluss Contact insert screw termination    	Stifteinsatz Male insert   Buchseinsatz Female insert 	C146 10A010 002 1  C146 10A010 102 1 (mit Drahtschutz with wire protection)	C146 10B010 002 1  C146 10B010 102 1 (mit Drahtschutz with wire protection)
Kontakteinsatz für gestanzte Kontakte Contact insert for stamped contacts    	Stifteinsatz Male insert   Buchseinsatz Female insert 	C146 10A010 000 1	C146 10B010 000 1
Kontakteinsatz für gedrehte Kontakte Contact insert for turned contacts    	Stifteinsatz Male insert   Buchseinsatz Female insert 	C146 10A010 500 1	C146 10B010 500 1

C 146 E

10 + 

Crimpkontakte  
Crimp contacts

Gestanzte Einzelkontakte / Stamped single contacts

Gestanzte Bandkontakte für Crimpzangen / Stamped contacts on reel for hand crimping tools

Gestanzte Bandkontakte für Crimpmaschinen / Stamped contacts on reel for crimp machines



Gedrehte Einzelkontakte  
Turned single contacts



200 / 100 Stück

200 / 100 pcs



2000 Stück  
(Zuführung links  
oder rechts)

2000 pcs  
(feeding left or  
right hand side)

Lieferform Supplied as	für Leiter- querschnitt for wire gauge	AWG	Stück- zahl Pieces	Bestell Nr. <sup>1)</sup> Stiftkontakt Male contact	Part No. <sup>1)</sup> Buchsenkontakt Female contact	Bestell Nr. <sup>1)</sup> Stiftkontakt Male contact	Part No. <sup>1)</sup> Buchsenkontakt Female contact
Gestanzte Einzelkontakte / Stamped single contacts				versilbert / silver plating		vergoldet / gold plating	
	0,5 - 1,5 mm <sup>2</sup>	20 - 16	100	VN01 025 0001 (101)	VN02 025 0001 (101)	VN01 025 0001 (102)	VN02 025 0001 (102)
	1,5 - 2,5 mm <sup>2</sup>	16 - 14	100	VN01 025 0010 (101)	VN02 025 0010 (101)	VN01 025 0010 (102)	VN02 025 0010 (102)
Gestanzte Bandkontakte für Crimpzangen / Stamped Contacts on reel for hand crimp tools							
	0,5 - 1,5 mm <sup>2</sup>	20 - 16	200	ZN01 025 0001 (1)	ZN02 025 0001 (1)	ZN01 025 0001 (2)	ZN02 025 0001 (2)
	1,5 - 2,5 mm <sup>2</sup>	16 - 14	100	ZN01 025 0010 (1)	ZN02 025 0010 (1)	ZN01 025 0010 (2)	ZN02 025 0010 (2)
Gestanzte Bandkontakte für Crimpmaschinen / Stamped contacts on reel for crimp machines							
Kontaktzuführung rechts Contact feeding right hand side	0,5 - 1,5 mm <sup>2</sup>	20 - 16	2000	HN01 025 0001 (1)	HN02 025 0001 (1)		
	1,5 - 2,5 mm <sup>2</sup>	16 - 14	2000	HN01 025 0010 (1)	HN02 025 0010 (1)		
Kontaktzuführung links Contact feeding left hand side	0,5 - 1,5 mm <sup>2</sup>	20 - 16	2000	TN01 025 0001 (1)	TN02 025 0001 (1)		
	1,5 - 2,5 mm <sup>2</sup>	16 - 14	2000	TN01 025 0010 (1)	TN02 025 0010 (1)		
Gedrehte Crimpkontakte / Turned crimp contacts							
Einzelkontakt Single contact	0,5 mm <sup>2</sup>	20	100	VN01 025 0035 (1)C	VN02 025 0035 (1)C	VN01 025 0035 (2)C	VN02 025 0035 (2)C
	0,75 - 1,0 mm <sup>2</sup>	18	100	VN01 025 0036 (1)C	VN02 025 0036 (1)C	VN01 025 0036 (2)C	VN02 025 0036 (2)C
	1,5 mm <sup>2</sup>	16	100	VN01 025 0037 (1)C	VN02 025 0037 (1)C	VN01 025 0037 (2)C	VN02 025 0037 (2)C
	2,5 mm <sup>2</sup>	14	100	VN01 025 0038 (1)C	VN02 025 0038 (1)C	VN01 025 0038 (2)C	VN02 025 0038 (2)C
	4,0 mm <sup>2</sup>	12	100	VN01 025 0039 (1)C	VN02 025 0039 (1)C	VN01 025 0039 (2)C	VN02 025 0039 (2)C

Montageanleitung, Steckbild / Assembly instruction, pin layout

Stifteinsatz  
Male insert

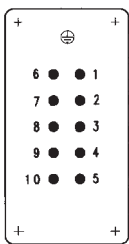

Buchseinsatz  
Female insert

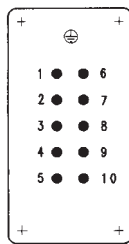

Montageausschnitt (Kontaktträger)  
Panel cut out (insert)

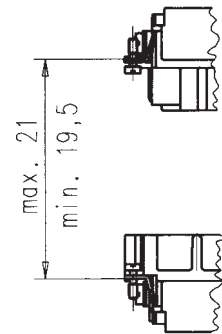
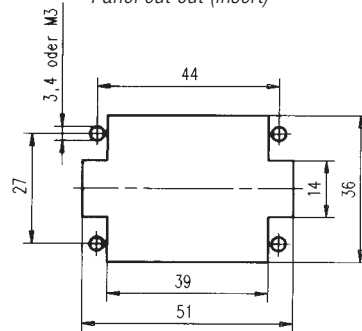

Derating Kurven / Derating curves

Gestanzte Kontakte  
Stamped contacts

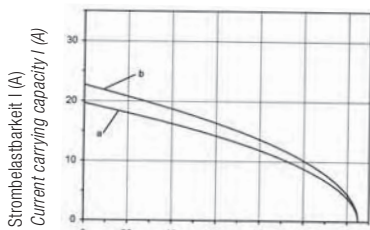

Bauelement Umgebungstemperatur  $T_u$  (°C)  
Ambient temperature  $T_{amb}$  (°C)

Kurve a: 1,5 mm<sup>2</sup> Leiterquerschnitt  
Curve a: 1,5 mm<sup>2</sup> wire gauge

Gedrehte Kontakte  
Turned contacts

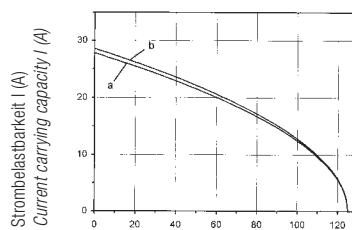

Bauelement Umgebungstemperatur  $T_u$  (°C)  
Ambient temperature  $T_{amb}$  (°C)

Kurve b: 2,5 mm<sup>2</sup> Leiterquerschnitt  
Curve b: 2,5 mm<sup>2</sup> wire gauge

Schraubanschluss  
Screw termination

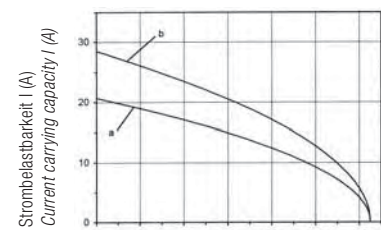

Bauelement Umgebungstemperatur  $T_u$  (°C)  
Ambient temperature  $T_{amb}$  (°C)

<sup>1)</sup> Erläuterung der Bestell-Nr. für die Kontakte siehe Seite 4  
Explanation of the Part No. for contacts see page 4

Abisolierlängen siehe S. 198  
Stripping length see p. 198

C 146 E

16 + 

Steckverbinder  
Connectors



400 V~ Kontakteinsatz für gestanzte Kontakte /  
Contact insert for stamped contacts

500 V~ Kontakteinsatz für Schraubanschluss und für gedrehte Kontakte /  
Contact insert for screw termination and for turned contacts

16 / 22 A

Gehäuse siehe Seite 138-145

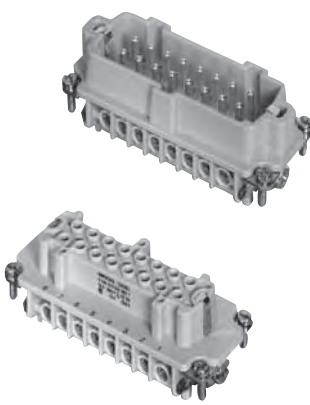
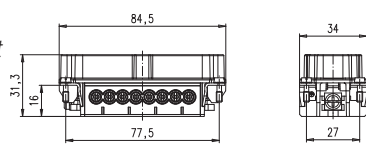
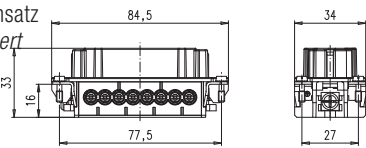
Housings see page 138-145

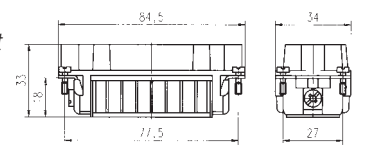
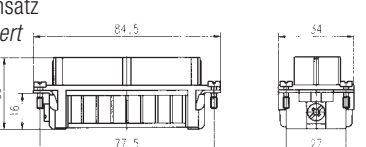
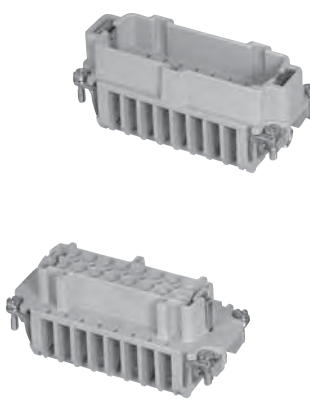
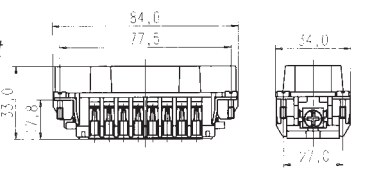
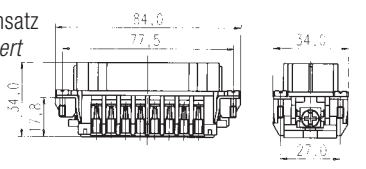
Bezeichnung - Abbildung Description - Figure	Maßzeichnung Drawing	Bestell Nr. / Part No.	
		Stifteinsatz / Male insert	Buchseinsatz / Female insert
Kontakteinsatz Schraubanschluss Contact insert screw termination  	Stifteinsatz Male insert   Buchseinsatz Female insert 	C146 10A016 002 1  C146 10A016 102 1 (mit Drahtschutz with wire protection)	C146 10B016 002 1  C146 10B016 102 1 (mit Drahtschutz with wire protection)
Kontakteinsatz für gestanzte Kontakte Contact insert for stamped contacts  	Stifteinsatz Male insert   Buchseinsatz Female insert 	C146 10A016 000 1	C146 10B016 000 1
Kontakteinsatz für gedrehte Kontakte Contact insert for turned contacts  	Stifteinsatz Male insert   Buchseinsatz Female insert 	C146 10A016 500 1	C146 10B016 500 1

C 146 E

16 + 

**Crimpkontakte**  
**Crimp contacts**

Gestanzte Einzelkontakte / Stamped single contacts

Gestanzte Bandkontakte für Crimpzangen / Stamped contacts on reel for hand crimping tools

Gestanzte Bandkontakte für Crimpmaschinen / Stamped contacts on reel for crimp machines



Gedrehte Einzelkontakte / Turned single contacts



200 / 100 Stück

200 / 100 pcs



2000 Stück  
(Zuführung links oder rechts)

2000 pcs  
(feeding left or right hand side)

Lieferform <i>Supplied as</i>	für Leiterquerschnitt <i>for wire gauge</i>	AWG	Stückzahl <i>Pieces</i>	Bestell Nr. <sup>1)</sup> Stiftkontakt <i>Male contact</i>	Part No. <sup>1)</sup> Buchsenkontakt <i>Female contact</i>	Bestell Nr. <sup>1)</sup> Stiftkontakt <i>Male contact</i>	Part No. <sup>1)</sup> Buchsenkontakt <i>Female contact</i>
Gestanzte Einzelkontakte / <i>Stamped single contacts</i>				versilbert / <i>silver plating</i>		vergoldet / <i>gold plating</i>	
	0,5 - 1,5 mm <sup>2</sup>	20 - 16	100	VN01 025 0001 (101)	VN02 025 0001 (101)	VN01 025 0001 (102)	VN02 025 0001 (102)
	1,5 - 2,5 mm <sup>2</sup>	16 - 14	100	VN01 025 0010 (101)	VN02 025 0010 (101)	VN01 025 0010 (102)	VN02 025 0010 (102)
Gestanzte Bandkontakte für Crimpzangen / <i>Stamped Contacts on reel for hand crimp tools</i>							
	0,5 - 1,5 mm <sup>2</sup>	20 - 16	200	ZN01 025 0001 (1)	ZN02 025 0001 (1)	ZN01 025 0001 (2)	ZN02 025 0001 (2)
	1,5 - 2,5 mm <sup>2</sup>	16 - 14	100	ZN01 025 0010 (1)	ZN02 025 0010 (1)	ZN01 025 0010 (2)	ZN02 025 0010 (2)
Gestanzte Bandkontakte für Crimpmaschinen / <i>Stamped contacts on reel for crimp machines</i>							
Kontaktzuführung rechts <i>Contact feeding right hand side</i>	0,5 - 1,5 mm <sup>2</sup>	20 - 16	2000	HN01 025 0001 (1)	HN02 025 0001 (1)		
	1,5 - 2,5 mm <sup>2</sup>	16 - 14	2000	HN01 025 0010 (1)	HN02 025 0010 (1)		
Kontaktzuführung links <i>Contact feeding left hand side</i>	0,5 - 1,5 mm <sup>2</sup>	20 - 16	2000	TN01 025 0001 (1)	TN02 025 0001 (1)		
	1,5 - 2,5 mm <sup>2</sup>	16 - 14	2000	TN01 025 0010 (1)	TN02 025 0010 (1)		
Gedrehte Crimpkontakte / <i>Turned crimp contacts</i>							
Einzelkontakt <i>Single contact</i>	0,5 mm <sup>2</sup>	20	100	VN01 025 0035 (1)C	VN02 025 0035 (1)C	VN01 025 0035 (2)C	VN02 025 0035 (2)C
	0,75 - 1,0 mm <sup>2</sup>	18	100	VN01 025 0036 (1)C	VN02 025 0036 (1)C	VN01 025 0036 (2)C	VN02 025 0036 (2)C
	1,5 mm <sup>2</sup>	16	100	VN01 025 0037 (1)C	VN02 025 0037 (1)C	VN01 025 0037 (2)C	VN02 025 0037 (2)C
	2,5 mm <sup>2</sup>	14	100	VN01 025 0038 (1)C	VN02 025 0038 (1)C	VN01 025 0038 (2)C	VN02 025 0038 (2)C
	4,0 mm <sup>2</sup>	12	100	VN01 025 0039 (1)C	VN02 025 0039 (1)C	VN01 025 0039 (2)C	VN02 025 0039 (2)C
Montageanleitung, Steckbild / <i>Assembly instruction, pin layout</i>							

Stifteinsatz  
*Male insert*

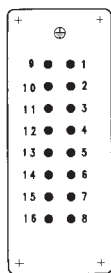

Buchseinsatz  
*Female insert*

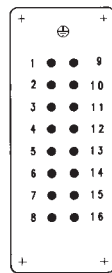

Montageausschnitt (Kontaktträger)  
*Panel cut out (insert)*

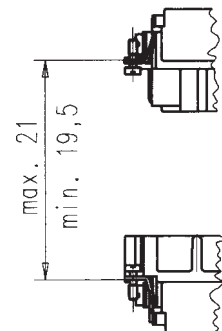
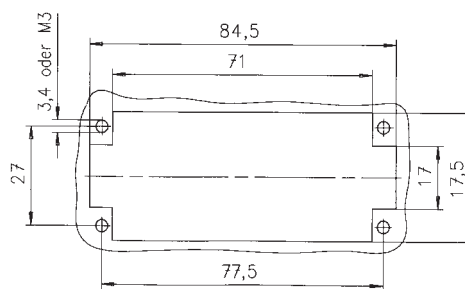

Derating Kurven / *Derating curves*

**Gestanzte Kontakte**  
**Stamped contacts**

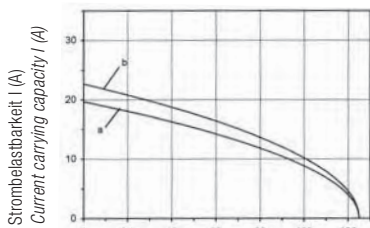

Bauelement Umgebungstemperatur  $T_u$  (°C)  
Ambient temperature  $T_{amb}$  (°C)

**Kurve a:** 1,5 mm<sup>2</sup> Leiterquerschnitt  
**Curve a:** 1,5 mm<sup>2</sup> wire gauge

**Gedrehte Kontakte**  
**Turned contacts**

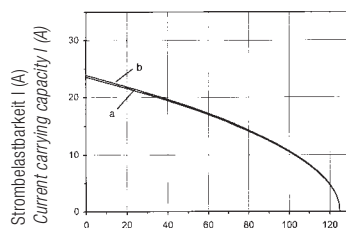

Bauelement Umgebungstemperatur  $T_u$  (°C)  
Ambient temperature  $T_{amb}$  (°C)

**Kurve b:** 2,5 mm<sup>2</sup> Leiterquerschnitt  
**Curve b:** 2,5 mm<sup>2</sup> wire gauge

**Schraubanschluss**  
**Screw termination**

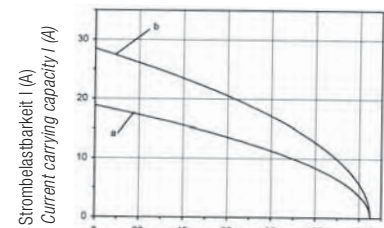

Bauelement Umgebungstemperatur  $T_u$  (°C)  
Ambient temperature  $T_{amb}$  (°C)

<sup>1)</sup> Erläuterung der Bestell-Nr. für die Kontakte siehe Seite 4  
*Explanation of the Part No. for contacts see page 4*

Abisolierlängen siehe S. 198  
*Stripping length see p. 198*



C 146 E

24 + 

Steckverbinder  
Connectors

400 V~ Kontakteinsatz für gestanzte Kontakte /  
Contact insert for stamped contacts

500 V~ Kontakteinsatz für Schraubanschluss und für gedrehte Kontakte /  
Contact insert for screw termination and for turned contacts

16 / 22 A

Gehäuse siehe Seite 146-153

Housings see page 146-153

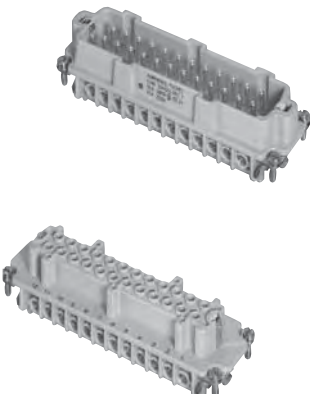
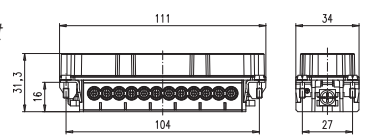
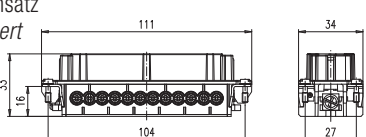
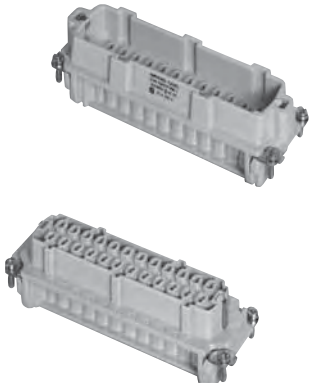
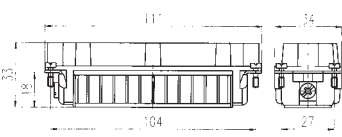
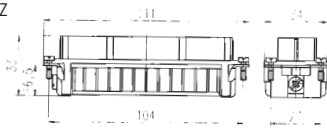
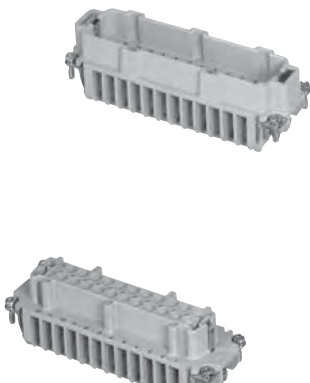
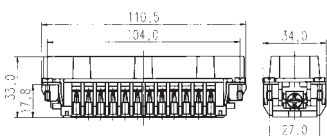
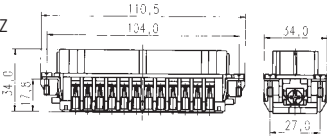
Bezeichnung - Abbildung Description - Figure	Maßzeichnung Drawing	Bestell Nr. / Part No.	
		Stifteinsatz / Male insert	Buchseneinsatz / Female insert
Kontakteinsatz Schraubanschluss Contact insert screw termination  	Stifteinsatz Male insert   Buchseneinsatz Female insert 	C146 10A024 002 1  C146 10A024 102 1 (mit Drahtschutz with wire protection)	C146 10B024 002 1  C146 10B024 102 1 (mit Drahtschutz with wire protection)
Kontakteinsatz für gestanzte Kontakte Contact insert for stamped contacts  	Stifteinsatz Male insert   Buchseneinsatz Female insert 	C146 10A024 000 1	C146 10B024 000 1
Kontakteinsatz für gedrehte Kontakte Contact insert for turned contacts  	Stifteinsatz Male insert   Buchseneinsatz Female insert 	C146 10A024 500 1	C146 10B024 500 1

C 146 E

24 + 

**Crimpkontakte**  
**Crimp contacts**

Gestanzte Einzelkontakte / Stamped single contacts

Gestanzte Bandkontakte für Crimpzangen / Stamped contacts on reel for hand crimping tools

Gestanzte Bandkontakte für Crimpmaschinen / Stamped contacts on reel for crimp machines



Gedrehte Einzelkontakte / Turned single contacts



200 / 100 Stück

200 / 100 pcs



2000 Stück  
(Zuführung links oder rechts)

2000 pcs  
(feeding left or right hand side)

Lieferform <i>Supplied as</i>	für Leiterquerschnitt <i>for wire gauge</i>	AWG	Stückzahl <i>Pieces</i>	Bestell Nr. <sup>1)</sup> Stiftkontakt <i>Male contact</i>	Part No. <sup>1)</sup> Buchsenkontakt <i>Female contact</i>	Bestell Nr. <sup>1)</sup> Stiftkontakt <i>Male contact</i>	Part No. <sup>1)</sup> Buchsenkontakt <i>Female contact</i>
Gestanzte Einzelkontakte / <i>Stamped single contacts</i>				versilbert / <i>silver plating</i>		vergoldet / <i>gold plating</i>	
	0,5 - 1,5 mm <sup>2</sup>	20 - 16	100	VN01 025 0001 (101)	VN02 025 0001 (101)	VN01 025 0001 (102)	VN02 025 0001 (102)
	1,5 - 2,5 mm <sup>2</sup>	16 - 14	100	VN01 025 0010 (101)	VN02 025 0010 (101)	VN01 025 0010 (102)	VN02 025 0010 (102)
Gestanzte Bandkontakte für Crimpzangen / <i>Stamped Contacts on reel for hand crimp tools</i>							
	0,5 - 1,5 mm <sup>2</sup>	20 - 16	200	ZN01 025 0001 (1)	ZN02 025 0001 (1)	ZN01 025 0001 (2)	ZN02 025 0001 (2)
	1,5 - 2,5 mm <sup>2</sup>	16 - 14	100	ZN01 025 0010 (1)	ZN02 025 0010 (1)	ZN01 025 0010 (2)	ZN02 025 0010 (2)
Gestanzte Bandkontakte für Crimpmaschinen / <i>Stamped contacts on reel for crimp machines</i>							
Kontaktzuführung rechts <i>Contact feeding right hand side</i>	0,5 - 1,5 mm <sup>2</sup>	20 - 16	2000	HN01 025 0001 (1)	HN02 025 0001 (1)		
	1,5 - 2,5 mm <sup>2</sup>	16 - 14	2000	HN01 025 0010 (1)	HN02 025 0010 (1)		
Kontaktzuführung links <i>Contact feeding left hand side</i>	0,5 - 1,5 mm <sup>2</sup>	20 - 16	2000	TN01 025 0001 (1)	TN02 025 0001 (1)		
	1,5 - 2,5 mm <sup>2</sup>	16 - 14	2000	TN01 025 0010 (1)	TN02 025 0010 (1)		
Gedrehte Crimpkontakte / <i>Turned crimp contacts</i>							
Einzelkontakt <i>Single contact</i>	0,5 mm <sup>2</sup>	20	100	VN01 025 0035 (1)C	VN02 025 0035 (1)C	VN01 025 0035 (2)C	VN02 025 0035 (2)C
	0,75 - 1,0 mm <sup>2</sup>	18	100	VN01 025 0036 (1)C	VN02 025 0036 (1)C	VN01 025 0036 (2)C	VN02 025 0036 (2)C
	1,5 mm <sup>2</sup>	16	100	VN01 025 0037 (1)C	VN02 025 0037 (1)C	VN01 025 0037 (2)C	VN02 025 0037 (2)C
	2,5 mm <sup>2</sup>	14	100	VN01 025 0038 (1)C	VN02 025 0038 (1)C	VN01 025 0038 (2)C	VN02 025 0038 (2)C
	4,0 mm <sup>2</sup>	12	100	VN01 025 0039 (1)C	VN02 025 0039 (1)C	VN01 025 0039 (2)C	VN02 025 0039 (2)C

Montageanleitung, Steckbild / *Assembly instruction, pin layout*

Stifteinsatz  
*Male insert*

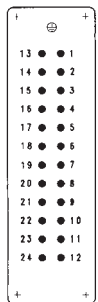

Buchseinsatz  
*Female insert*

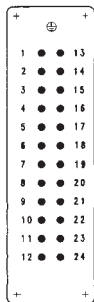

Montageausschnitt (Kontaktträger)  
*Panel cut out (insert)*

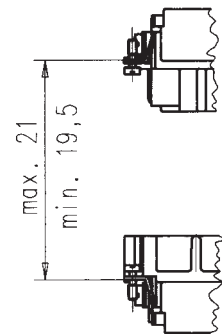
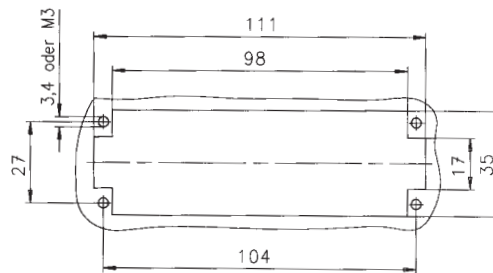

Derating Kurven / *Derating curves*

**Gestanzte Kontakte**  
**Stamped contacts**

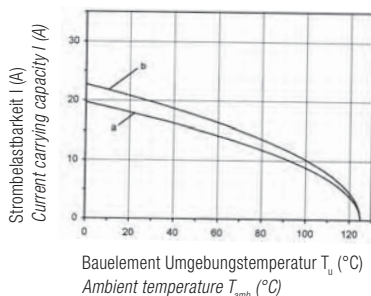

**Kurve a:** 1,5 mm<sup>2</sup> Leiterquerschnitt  
**Curve a:** 1,5 mm<sup>2</sup> wire gauge

**Gedrehte Kontakte**  
**Turned contacts**

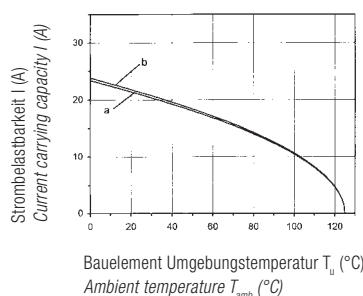

**Kurve b:** 2,5 mm<sup>2</sup> Leiterquerschnitt  
**Curve b:** 2,5 mm<sup>2</sup> wire gauge

**Schraubanschluss**  
**Screw termination**

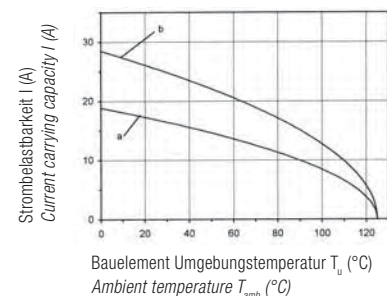

<sup>1)</sup> Erläuterung der Bestell-Nr. für die Kontakte siehe Seite 4  
*Explanation of the Part No. for contacts see page 4*

Abisolierlängen siehe S. 198  
*Stripping length see p. 198*

C 146 E

48 + 

Steckverbinder  
Connectors

400 V~ Kontakteinsatz für gestanzte Kontakte /  
Contact insert for stamped contacts

500 V~ Kontakteinsatz für Schraubanschluss und für gedrehte Kontakte /  
Contact insert for screw termination and for turned contacts

16 / 22 A

Gehäuse auf Anfrage  
Housings upon request

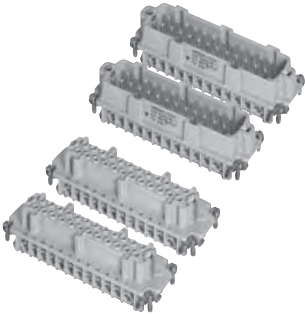
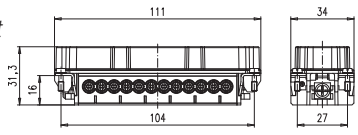
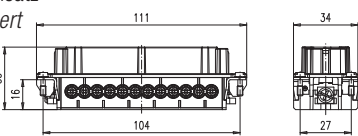
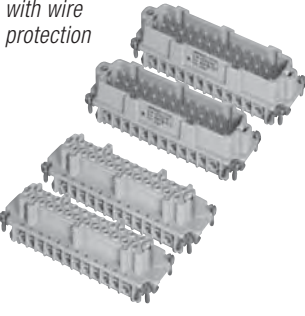
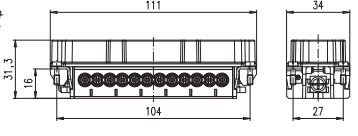
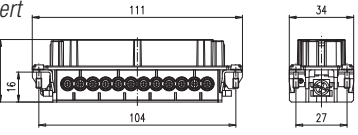
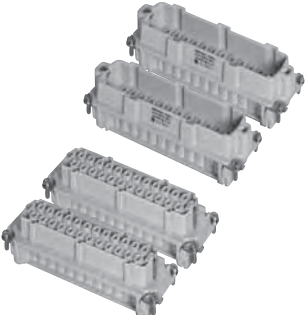
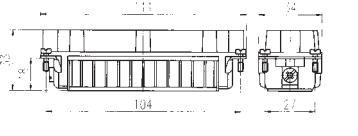
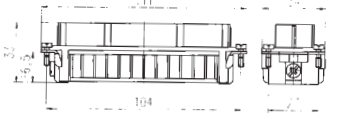
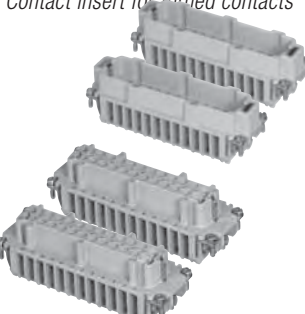
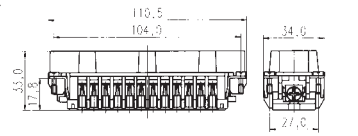
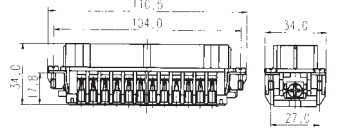
Bezeichnung - Abbildung Description - Figure	Maßzeichnung Drawing	Bestell Nr. / Part No.	
		Stifteinsatz / Male insert	Buchseinsatz / Female insert
Kontakteinsatz Schraubanschluss Contact insert screw termination  	Stifteinsatz Male insert   Buchseinsatz Female insert 	C146 10A024 002 1 + C146 10A024 002 1	C146 10B024 002 1 + C146 10B024 002 1
Kontakteinsatz Schraubanschluss mit Drahtschutz Contact insert screw termination with wire protection  	Stifteinsatz Male insert   Buchseinsatz Female insert 	C146 10A024 102 1 + C146 10A024 102 1	C146 10B024 102 1 + C146 10B024 102 1
Kontakteinsatz für gestanzte Kontakte Contact insert for stamped contacts  	Stifteinsatz Male insert   Buchseinsatz Female insert 	C146 10A024 000 1 + C146 10A024 005 1	C146 10B024 000 1 + C146 10B024 005 1
Kontakteinsatz für gedrehte Kontakte Contact insert for turned contacts  	Stifteinsatz Male insert   Buchseinsatz Female insert 	C146 10A024 500 1 + C146 10A024 505 1	C146 10B024 500 1 + C146 10B024 505 1

C 146 E

48 + 

**Crimpkontakte**  
**Crimp contacts**

Gestanzte Einzelkontakte / Stamped single contacts    Gestanzte Bandkontakte für Crimpzangen / Stamped contacts on reel for hand crimping tools    Gestanzte Bandkontakte für Crimpmaschinen / Stamped contacts on reel for crimp machines



Gedrehte Einzelkontakte / Turned single contacts



200 / 100 Stück

200 / 100 pcs



Lieferform <i>Supplied as</i>	für Leiterquerschnitt <i>for wire gauge</i>	AWG	Stückzahl <i>Pieces</i>	Bestell Nr. <sup>1)</sup> Stiftkontakt <i>Male contact</i>	Part No. <sup>1)</sup> Buchsenkontakt <i>Female contact</i>	Bestell Nr. <sup>1)</sup> Stiftkontakt <i>Male contact</i>	Part No. <sup>1)</sup> Buchsenkontakt <i>Female contact</i>
Gestanzte Einzelkontakte / <i>Stamped single contacts</i>				versilbert / <i>silver plating</i>		vergoldet / <i>gold plating</i>	
	0,5 - 1,5 mm <sup>2</sup>	20 - 16	100	VN01 025 0001 (101)	VN02 025 0001 (101)	VN01 025 0001 (102)	VN02 025 0001 (102)
	1,5 - 2,5 mm <sup>2</sup>	16 - 14	100	VN01 025 0010 (101)	VN02 025 0010 (101)	VN01 025 0010 (102)	VN02 025 0010 (102)
Gestanzte Bandkontakte für Crimpzangen / <i>Stamped Contacts on reel for hand crimp tools</i>							
	0,5 - 1,5 mm <sup>2</sup>	20 - 16	200	ZN01 025 0001 (1)	ZN02 025 0001 (1)	ZN01 025 0001 (2)	ZN02 025 0001 (2)
	1,5 - 2,5 mm <sup>2</sup>	16 - 14	100	ZN01 025 0010 (1)	ZN02 025 0010 (1)	ZN01 025 0010 (2)	ZN02 025 0010 (2)
Gestanzte Bandkontakte für Crimpmaschinen / <i>Stamped contacts on reel for crimp machines</i>							
Kontaktzuführung rechts <i>Contact feeding right hand side</i>	0,5 - 1,5 mm <sup>2</sup>	20 - 16	2000	HN01 025 0001 (1)	HN02 025 0001 (1)		
	1,5 - 2,5 mm <sup>2</sup>	16 - 14	2000	HN01 025 0010 (1)	HN02 025 0010 (1)		
Kontaktzuführung links <i>Contact feeding left hand side</i>	0,5 - 1,5 mm <sup>2</sup>	20 - 16	2000	TN01 025 0001 (1)	TN02 025 0001 (1)		
	1,5 - 2,5 mm <sup>2</sup>	16 - 14	2000	TN01 025 0010 (1)	TN02 025 0010 (1)		
Gedrehte Crimpkontakte / <i>Turned crimp contacts</i>							
Einzelkontakt <i>Single contact</i>	0,5 mm <sup>2</sup>	20	100	VN01 025 0035 (1)C	VN02 025 0035 (1)C	VN01 025 0035 (2)C	VN02 025 0035 (2)C
	0,75 - 1,0 mm <sup>2</sup>	18	100	VN01 025 0036 (1)C	VN02 025 0036 (1)C	VN01 025 0036 (2)C	VN02 025 0036 (2)C
	1,5 mm <sup>2</sup>	16	100	VN01 025 0037 (1)C	VN02 025 0037 (1)C	VN01 025 0037 (2)C	VN02 025 0037 (2)C
	2,5 mm <sup>2</sup>	14	100	VN01 025 0038 (1)C	VN02 025 0038 (1)C	VN01 025 0038 (2)C	VN02 025 0038 (2)C
	4,0 mm <sup>2</sup>	12	100	VN01 025 0039 (1)C	VN02 025 0039 (1)C	VN01 025 0039 (2)C	VN02 025 0039 (2)C
Montageanleitung, Steckbild / <i>Assembly instruction, pin layout</i>							

Stifteinsatz  
*Male insert*

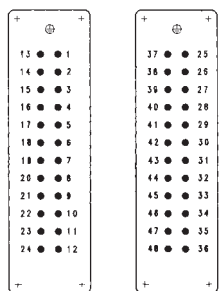

Buchseinsatz  
*Female insert*

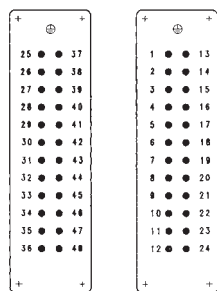

Montageausschnitt (Kontaktträger)  
*Panel cut out (insert)*

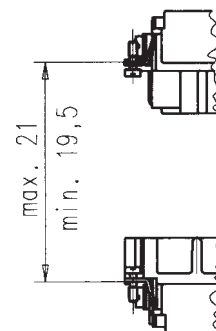
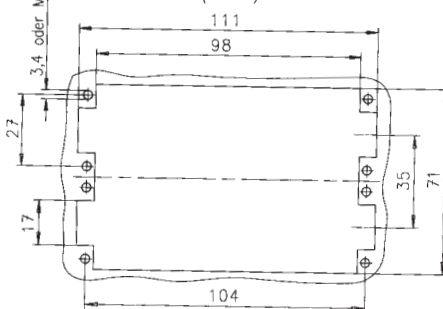

Derating Kurven / *Derating curves*

**Gestanzte Kontakte**  
**Stamped contacts**

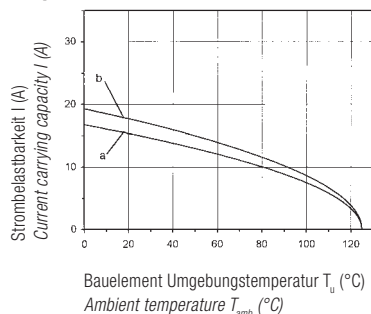

**Kurve a:** 1,5 mm<sup>2</sup> Leiterquerschnitt  
**Curve a:** 1,5 mm<sup>2</sup> wire gauge

**Gedrehte Kontakte**  
**Turned contacts**

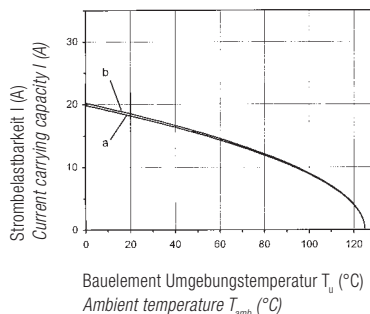

**Kurve b:** 2,5 mm<sup>2</sup> Leiterquerschnitt  
**Curve b:** 2,5 mm<sup>2</sup> wire gauge

**Schraubanschluss**  
**Screw termination**

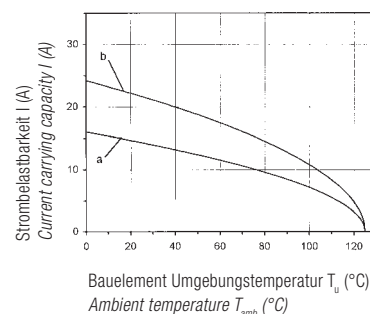

<sup>1)</sup> Erläuterung der Bestell-Nr. für die Kontakte siehe Seite 4  
*Explanation of the Part No. for contacts see page 4*

Abisolierlängen siehe S. 198  
*Stripping length see p. 198*

# C 146 E

## Werkzeuge <sup>1)</sup> Tools <sup>1)</sup>

Bezeichnung / Description	für Leiterquerschnitt for wire gauge	Bestell Nr. / Part No.		Werkzeuge / Tools
		Kontaktaufnahme / Contact locator	Crimpbacken / Crimping dies	
Lösewerkzeug für gestanzte Kontakte Removal tool for stamped contacts	–	–	–	FG 0200 146 1
Crimpzange für gestanzte Einzelkontakte Crimping tool for stamped single contacts	0,5 - 1,5 mm <sup>2</sup> 1,5 - 2,5 mm <sup>2</sup>	TA 0004 146 000 1 TA 0005 146 000 3	TA 0000 163 TA 0000 141	TA 0000
4-Kerb Crimpzange für gedrehte Kontakte 4-indent crimping tool for turned contacts	0,5 - 4,0 mm <sup>2</sup>	–	–	TB 0600 146 <sup>2)</sup>

<sup>1)</sup> Weitere Informationen siehe Katalog „Werkzeuge“ / Further information see catalogue „Tools“



<sup>2)</sup> Incl. Prüfstiftset + Kontaktaufnahme / incl. calibration pin set + contact locator









# C 146 EE

EE

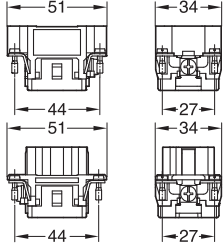

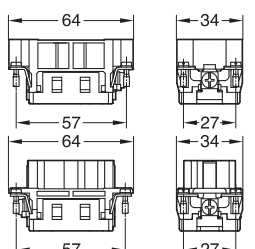
Hauptmerkmale		Main characteristics	
<ul style="list-style-type: none"> <li>• Bemessungsspannung 500 V (600 V UL / CSA)</li> <li>• Bemessungsstrom 16 A</li> <li>• Anschlusstechnik: crimpen</li> <li>• Polzahl: 10, 18, 32, 46</li> </ul>			
Zulassungen / Approvals Prüfstelle / Testhouse		Kennwerte / Characteristics	Zulassungs-Nummer / Approval-No.
UL		600 V, 15 A	E 63093
CSA		600 V, 16 A	172062-1027396 (LR 48323-2)
<p>Zulassungen beziehen sich im allgemeinen auf repräsentative Ausführungen der Steckverbinderserie. Prüfumfang und Prüfvorschrift auf Anfrage.</p>		<p><i>In general approvals refer to representative versions of the connector series. Extent and specification of tests upon request.</i></p>	

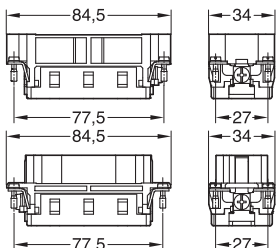
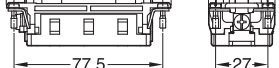
**C 146 EE****500 V~****16 A****Connectors****für gedrehte Kontakte  
for turned contacts****Gehäuse siehe Seite 126-153  
Housings see page 126-153**

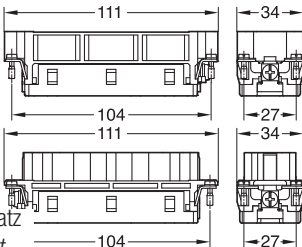
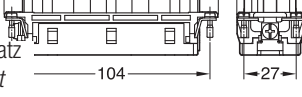
Bezeichnung <i>Description</i>	Maßzeichnung <i>Drawing</i>	Bestell Nr. / Part No.	
		Stifteinsatz / Male insert	Buchseinsatz / Female insert
Kontakteinsatz <b>10 + ⊕</b> Contact insert <b>10 + ⊕</b> 	Stifteinsatz Male insert  Buchseinsatz Female insert 	C146 10A010 500 10	C146 10B010 500 10
Kontakteinsatz <b>18 + ⊕</b> Contact insert <b>18 + ⊕</b> 	Stifteinsatz Male insert  Buchseinsatz Female insert 	C146 10A018 500 10	C146 10B018 500 10
Kontakteinsatz <b>32 + ⊕</b> Contact insert <b>32 + ⊕</b> 	Stifteinsatz Male insert  Buchseinsatz Female insert 	C146 10A032 500 10	C146 10B032 500 10
Kontakteinsatz <b>46 + ⊕</b> Contact insert <b>46 + ⊕</b> 	Stifteinsatz Male insert  Buchseinsatz Female insert 	C146 10A046 500 10	C146 10B046 500 10

**Montageanleitung / Assembly instruction**

Montageausschnitt (Kontaktträger)  
 Panel cut out (insert)

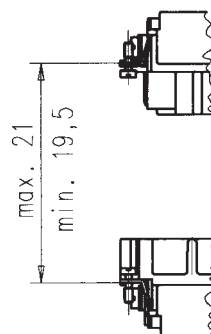
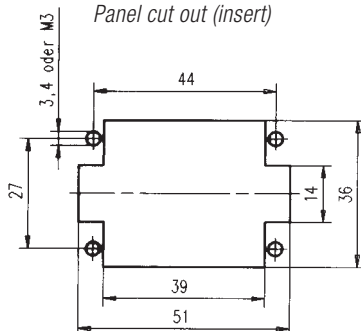

# C 146 EE

## Crimp contacts



Gedrehte 2,5 mm Kontakte  
Turned 2,5 mm contacts

### Steckbild, Ansicht Anschlussseite / Pin Layout, View from termination side

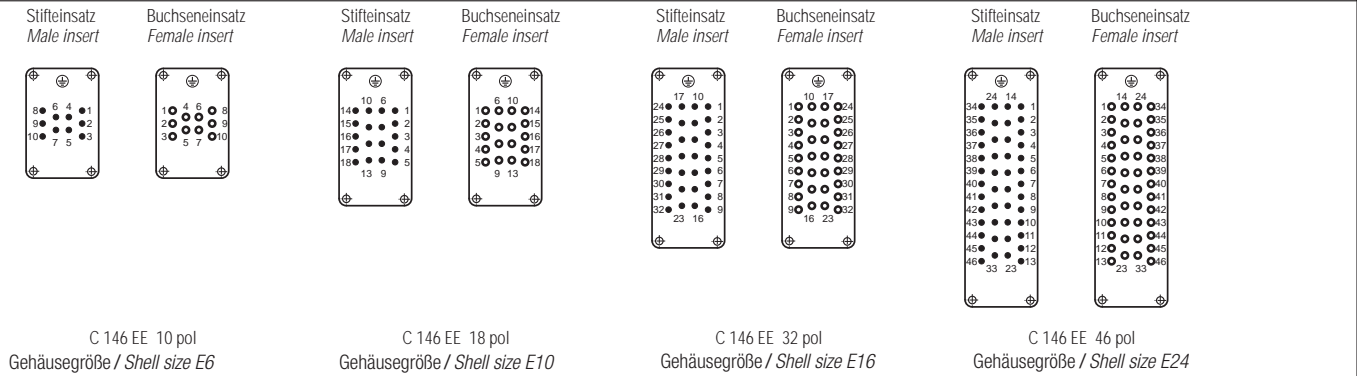

EE

Lieferform Supplied as	für Leiter- querschnitt for wire gauge	AWG	Stück- zahl Pieces	Bestell Nr. <sup>1)</sup> Stiftkontakt Male contact	Part No. <sup>1)</sup> Buchsenkontakt Female contact	Bestell Nr. <sup>1)</sup> Stiftkontakt Male contact	Part No. <sup>1)</sup> Buchsenkontakt Female contact
Gedrehte Crimpkontakte / Turned Crimp Contacts				versilbert / silver plating		vergoldet / gold plating	
Einzelkontakte Single contact	0,5 mm <sup>2</sup>	20	100	VN01 025 0035 (1)C	VN02 025 0035 (1)C	VN01 025 0035 (2)C	VN02 025 0035 (2)C
	0,75 - 1,0 mm <sup>2</sup>	18	100	VN01 025 0036 (1)C	VN02 025 0036 (1)C	VN01 025 0036 (2)C	VN02 025 0036 (2)C
	1,5 mm <sup>2</sup>	16	100	VN01 025 0037 (1)C	VN02 025 0037 (1)C	VN01 025 0037 (2)C	VN02 025 0037 (2)C
	2,5 mm <sup>2</sup>	14	100	VN01 025 0038 (1)C	VN02 025 0038 (1)C	VN01 025 0038 (2)C	VN02 025 0038 (2)C
	4,0 mm <sup>2</sup>	12	100	VN01 025 0039 (1)C	VN02 025 0039 (1)C	VN01 025 0039 (2)C	VN02 025 0039 (2)C
Kontaktlösewerkzeug Contact removal tool				FG 0300 146 (7)			

### Derating Kurven / Derating curves

#### C146 EE 10 pol

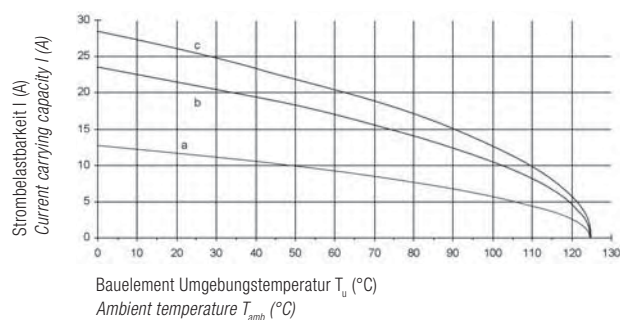

#### C146 EE 18 pol

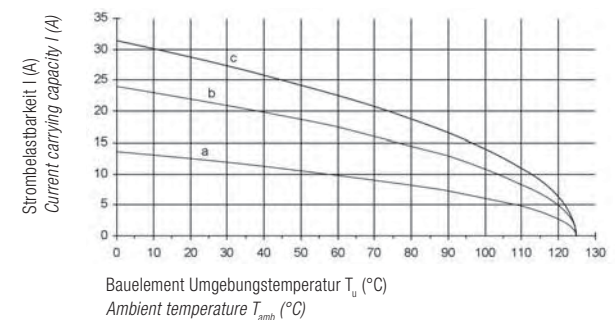

#### C146 EE 32 pol

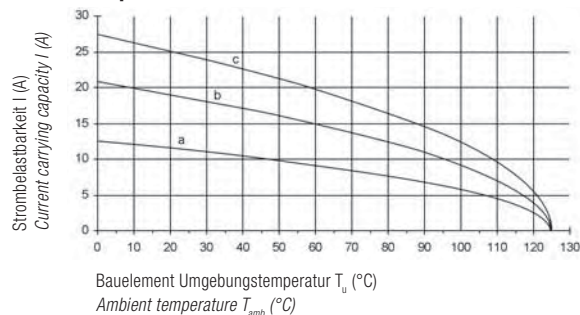

#### C146 EE 46 pol

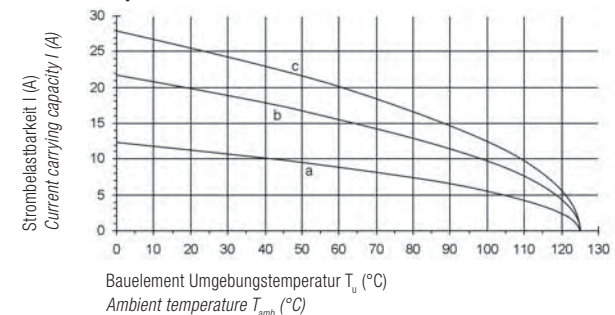

**Kurve a:** 0,5 mm<sup>2</sup> Anschlussquerschnitt  
**Curve a:** 0,5 mm<sup>2</sup> wire gauge

**Kurve b:** 2,5 mm<sup>2</sup> Anschlussquerschnitt  
**Curve b:** 2,5 mm<sup>2</sup> wire gauge

**Kurve c:** 4,0 mm<sup>2</sup> Anschlussquerschnitt  
**Curve c:** 4,0 mm<sup>2</sup> wire gauge

Abisolierlängen siehe S. 198 / Stripping length see p. 198

Allgemeine Kennwerte	General Characteristics	Norm / Standard	Wert / Value			
Polzahl	Number of contacts		10 + ⊕	18 + ⊕	32 + ⊕	46 + ⊕
Anschluss technik	Termination technique		crimpen / crimp			
Anschlussquerschnitt	Wire gauge		0,5 mm <sup>2</sup> - 4,0 mm <sup>2</sup>			
Brennbarkeit	Flammability	UL 94	V-0			
Elektrische Kennwerte	Electrical Characteristics					
Bemessungsspannung	Rated voltage	IEC 60664-1	500 V (600 V UL / CSA)			
Verschmutzungsgrad	Pollution degree	IEC 60664-1	3			
Überspannungskategorie	Installation (overvoltage) category	IEC 60664-1	III			
Isolierstoffgruppe	Material group	IEC 60664-1	III b			
Bemessungs-Stoßspannung	Rated impulse withstand voltage	IEC 60664-1	6 kV			
Spannungsfestigkeit	Voltage proof	IEC 60512-2; Test 4 a	3 kV			
Strombelastbarkeit	Current carrying capacity	IEC 60512-3; Test 5 b	siehe Derating Kurven / see derating curves			
Bemessungsstrom $T_u = 40\text{ °C}$	Rated current $T_{amb} = 40\text{ °C}$		16 A			
Durchgangswiderstand	Contact resistance	IEC 60512-2; Test 2 a	≤ 5 m Ω			
Isolationswiderstand	Insulation resistance	IEC 60512-2; Test 3 a	≥ 10 <sup>12</sup> Ω <sup>1)</sup>			
Luftstrecke	Clearance	IEC 60664-1	> 5,5 mm			
Kriechstrecke	Creepage	IEC 60664-1	> 10 mm			
Klimatische Kennwerte	Climatical Characteristics					
Prüfklasse	Climatic category	IEC 60068-1	40 / 100 / 21			
Obere Grenztemperatur	Upper temperature	IEC 60512-6; Test 11 i	+ 100 °C / 1000 h			
Untere Grenztemperatur	Lower temperature	IEC 60512-6; Test 11 i	- 40 °C			
Mechanische Kennwerte	Mechanical Characteristics					
Mechanische Lebensdauer	Mechanical operation	IEC 60512-5; Test 9 a	≥ 500 Steckzyklen / mating cycles			
IP-Schutzart Stifteinsatz	IP-degree of protection pin insert	IEC 60529	ungesteckt/unmated IP00	gesteckt/mated IP20		
IP-Schutzart Buchseneinsatz	IP-degree of protection socket insert	IEC 60529	ungesteckt/unmated IP20	gesteckt/mated IP20		
Werkstoffe	Materials					
Kontakteinsatz	Insert		PC			
Kontakte	Contacts		CuZn (Messing / brass)			
Kontaktoberfläche	Contact plating		Ag (silber / silver)			
Farbe	Colour		grau / grey			

<sup>1)</sup> Bei Beanspruchung > 10<sup>10</sup> Ω / Under operating conditions > 10<sup>10</sup> Ω



# C 146 E/FE/KO

E/FE/KO

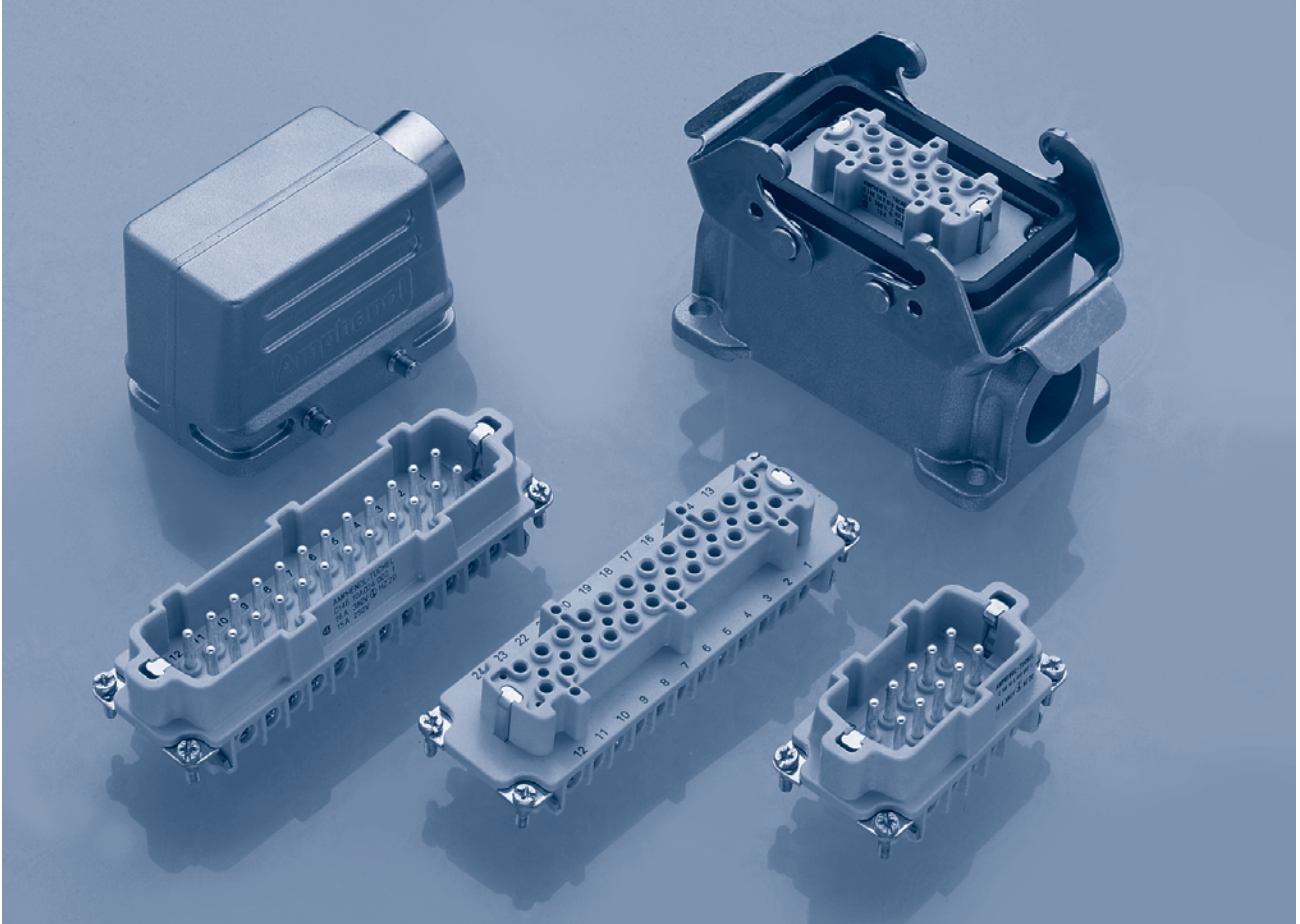

## Hauptmerkmale

- Bemessungsspannung 400 V
- Material Kontakte: Eisen-Konstantan
- Bemessungsstrom 10 A
- Polzahl: 6, 10, 16, 24

## Main characteristics

- Rated voltage 400 V
- Material contacts: iron-constantan
- Rated current 10 A
- Number of contacts: 6, 10, 16, 24



**Kurzinformation  
Brief information**

Bezeichnung - Abbildung

Description - Figure

**Steckverbinder mit Eisen-(FE) und Konstantan(KO)-Kontaktelementen**

finden vornehmlich in der Steuer- und Regeltechnik ihren Einsatz, und zwar dort, wo es gilt, zwischen Eisen- bzw. Konstantan-Leitungen „Schnittstellen“ zu schaffen. FE/KO-Kabel werden üblicherweise als Verbindungsglied zwischen Thermoelement und Regelgerät eingesetzt.

Z. B. : Messen und Regeln der Temperatur in Kunststoff-Spritzformen Spritzformen (Heißkanal-Anspritzung) mittels Thermofühler und elektronischem Regelgerät.

Durch das Einbringen von FE/KO-Steckverbindern in die „Thermofühlerleitung“ werden die Messergebnisse verfeinert, d. h. die Regelungsgenauigkeit wird stark reduziert.

**Soll-Wert-Abweichung bei verschiedenen Kontaktwerkstoff-Paarungen**

Kontaktwerkstoffe Soll.-Temp.	ohne Thermo-Kontakte		mit Thermo-Kontakte	
	MS/FE	MS/KO	FE/FE	KO/KO
100 °C	+ 4 %	- 16 %	- 4 %	- 2 %
200 °C	+ 2,5 %	- 8 %	- 3 %	- 1,5 %
300 °C	+ 1,3 %	- 12,7 %	- 1,3 %	0 %
400 °C	+ 1,5 %	- 4,5 %	- 1,0 %	0 %

Die Werte sind auf eine Umgebungstemperatur von 100 °C bezogen.

Die Ursache der Sollwert-Abweichung (Übertragungsverlust) bei Steckverbindern mit Messingkontakten liegt in der selbsterzeugenden Thermospannung (hervorgerufen durch den Wechsel von FE-Draht zu Messing-Kontaktelement) bzw. durch die Temperaturschwankungen an den Kontaktelementen.

**Einsatz von Thermo-Werkstoffen**

in Abhängigkeit der Messtemperatur

Temperaturbereich	Temperaturbereich
< 150 °C	beliebig / Widerstandsmessung
150 °C - 450 °C	FE-KO (Eisen/Konstantan)
450 °C - ca. 1000 °C	Ni/Cr - Ni (Nickel/Cromleg./Nickel)

**Faktoren, die das Messergebnis zusätzlich beeinflussen**

- schwankende Umgebungstemperaturen (am Steckverbinder)

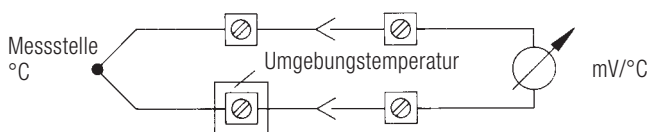

**Connectors with iron (FE) and constantan (CO) contacts**

are basically used in measuring and control circuits to serve as interface between FE/CO thermocouples and control unit, i. e. temperature control of moulds in injection moulding machines.

Through the use of FE/CO connectors in the thermocouple circuit the measuring results are more accurate, thus the tolerance of the temperature control is much narrower.

Amphenol's Industrial Connectors with iron (FE) and Constantan (CO) contacts are used to connect FE/CO thermocouples with electronic signal amplifiers in measuring and control circuits, i. e. for temperature control of moulding machines.

**Errors with various combinations**

Contact Material Nominal Temp.	without Thermo Contacts		with Thermo Contacts	
	MS/FE	MS/KO	FE/FE	KO/KO
100 °C	+ 4 %	- 16 %	- 4 %	- 2 %
200 °C	+ 2,5 %	- 8 %	- 3 %	- 1,5 %
300 °C	+ 1,3 %	- 12,7 %	- 1,3 %	0 %
400 °C	+ 1,5 %	- 4,5 %	- 1,0 %	0 %

The connection of unlike metals (FE/Brass and CO/Brass) generate thermoelectric voltage errors in the measuring circuit caused by the flow from iron wire to the brass contact or by temperature changes at the contact elements.

By using FE/CO contacts respectively these deviations will be minimized.

**Material / Temperature Range**

Temperatur range	Material/measurement procedure
< 150 °C	any/Resistance measurement
150 °C - 450 °C	FE-CO (iron/Constantan)
450 °C - approx. 1000 °C	Ni/Cr-Ni (Nickel/Chrome/Nickel)

**Temperature changes cause errors:**

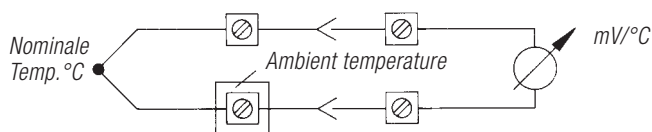

Allgemeine Kennwerte	General Characteristics	Norm / Standard	Wert / Value			
Polzahl	Number of contacts		6 + ⊕	10 + ⊕	16 + ⊕	24 + ⊕
Anschluss technik	Termination technique		schrauben / screw			
Anschlussquerschnitt	Wire gauge		0,25 mm <sup>2</sup> - 2,5 mm <sup>2</sup>			
Brennbarkeit	Flammability	UL 94	V-0			
Elektrische Kennwerte	Electrical Characteristics					
Bemessungsspannung	Rated voltage	IEC 60664-1	400 V			
Verschmutzungsgrad	Pollution degree	IEC 60664-1	3			
Überspannungskategorie	Installation (overvoltage) category	IEC 60664-1	III			
Isolierstoffgruppe	Material group	IEC 60664-1	III b			
Bemessungs-Stoßspannung	Rated impulse withstand voltage	IEC 60664-1	6,0 kV			
Spannungsfestigkeit	Voltage proof	IEC 60512-2; Test 4 a	2,8 kV			
Bemessungsstrom $T_u = 40\text{ °C}$	Rated current $T_{amb} = 40\text{ °C}$	IEC 60512-3	10 A			
Durchgangswiderstand	Contact resistance	IEC 60512-2; Test 2 a	≤ 10 m Ω			
Isolationswiderstand	Insulation resistance	IEC 60512-2; Test 3 a	≥ 10 <sup>12</sup> Ω <sup>1)</sup>			
Klimatische Kennwerte	Climatical Characteristics					
Prüfklasse	Climatic category	IEC 60068-1	40 / 100 / 21			
Obere Grenztemperatur	Upper temperature	IEC 60512-6; Test 11 i	+ 100 °C / 1000 h			
Untere Grenztemperatur	Lower temperature	IEC 60512-6; Test 11 i	- 40 °C			
Mechanische Kennwerte	Mechanical Characteristics					
Steck- und Ziehkraft	Insertion and withdrawal forces	IEC 60512-7; Test 13 b	< 40 N	< 70 N	< 95 N	< 165 N
<sup>2)</sup> IP-Schutzart Stifteinsatz	IP-degree of protection pin insert	IEC 60529	ungesteckt/unmated IP00		gesteckt/mated IP20	
<sup>2)</sup> IP-Schutzart Buchseneinsatz	IP-degree of protection socket insert	IEC 60529	ungesteckt/unmated IP20		gesteckt/mated IP20	
Gewicht Stifteinsatz	Weight pin insert		45 g	60 g	78 g	105 g
Gewicht Buchseneinsatz	Weight socket insert		45 g	60 g	78 g	105 g
Mechanische Lebensdauer	Mechanical operation	IEC 60512-5; Test 9 a	≥ 100 Steckzyklen / mating cycles			
Werkstoffe	Materials					
Material Kontakteinsatz	Material insert		PA, GV (Polyamid)			
Material Kontakte	Material contacts		Eisen / iron; gal cd 4 Konstantan = roh; constantan = without plating			
Farbton	Colour		grau / grey RAL 7032			

<sup>1)</sup> Bei Beanspruchung >10<sup>10</sup> Ω / Under operating conditions > 10<sup>10</sup> Ω

<sup>2)</sup> IP-Schutzart im Anschlussbereich der Schraubausführung IP 10 / IP-degree of protection on termination side of screw version IP 10









C 146 E FE-KO

6 -24 + 

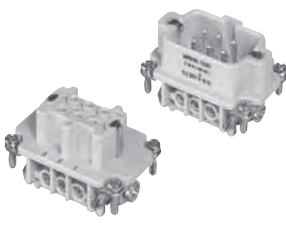
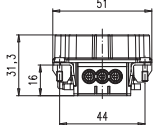
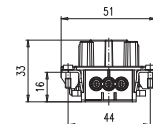
Steckverbinder mit Eisen-Konstantan-Kontakten  
Connectors with iron-constantan contacts

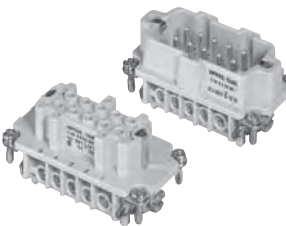
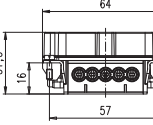
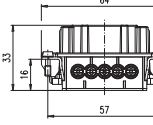
Steckverbinder  
Connectors

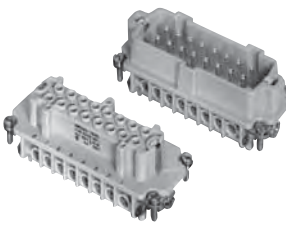
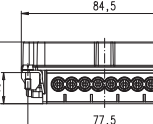
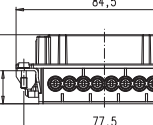
Gehäuse siehe Seite 126-153  
Housings see page 126-153

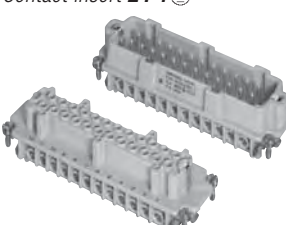
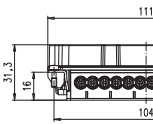
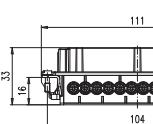
Bezeichnung - Abbildung Description - Figure	Maßzeichnung Drawing	Bestell Nr. / Part No.	
		Stifteinsatz / Male insert	Buchseinsatz / Female insert
Kontakteinsatz 6  <sup>1)</sup> Contact insert 6  <sup>1)</sup> 	Stifteinsatz Male insert  Buchseinsatz Female insert 	C146 10A006 810 1	C146 10B006 810 1
Kontakteinsatz 10  <sup>1)</sup> Contact insert 10  <sup>1)</sup> 	Stifteinsatz Male insert  Buchseinsatz Female insert 	C146 10A010 810 1	C146 10B010 810 1
Kontakteinsatz 16  <sup>1)</sup> Contact insert 16  <sup>1)</sup> 	Stifteinsatz Male insert  Buchseinsatz Female insert 	C146 10A016 810 1	C146 10B016 810 1
Kontakteinsatz 24  <sup>1)</sup> Contact insert 24  <sup>1)</sup> 	Stifteinsatz Male insert  Buchseinsatz Female insert 	C146 10A024 810 1	C146 10B024 810 1

Steckbild / pin layout

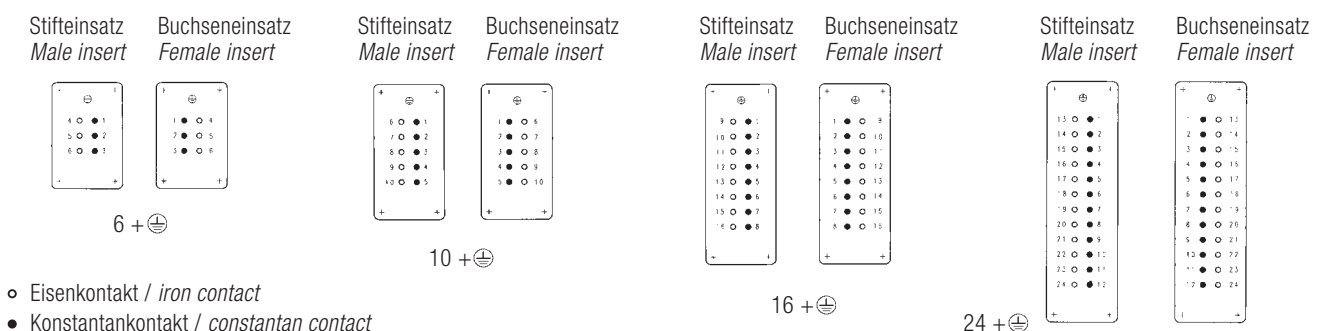





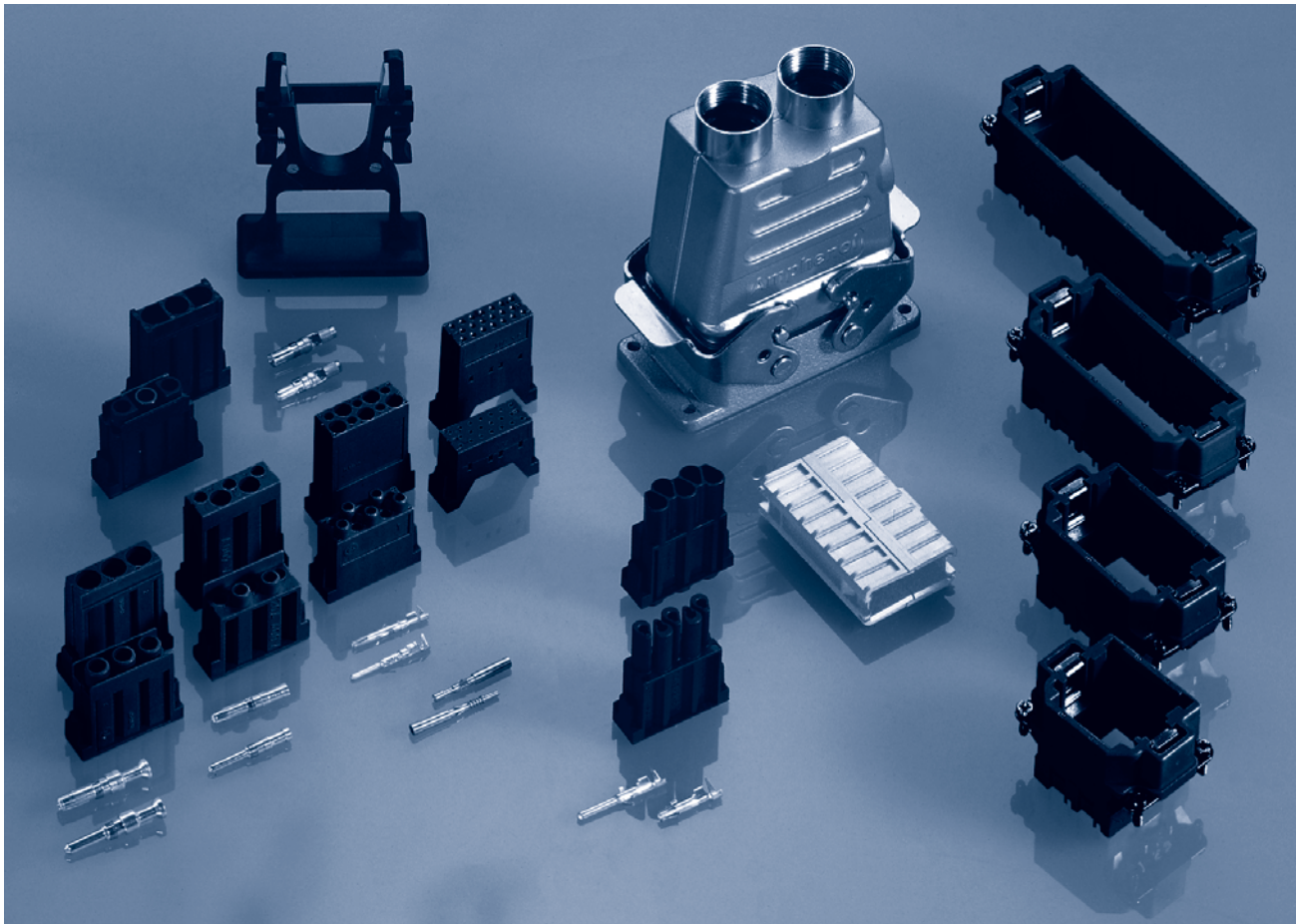



<sup>1)</sup> mit Drahtschutz / with wire protection

# C 146 M





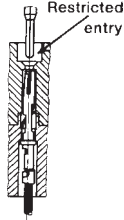
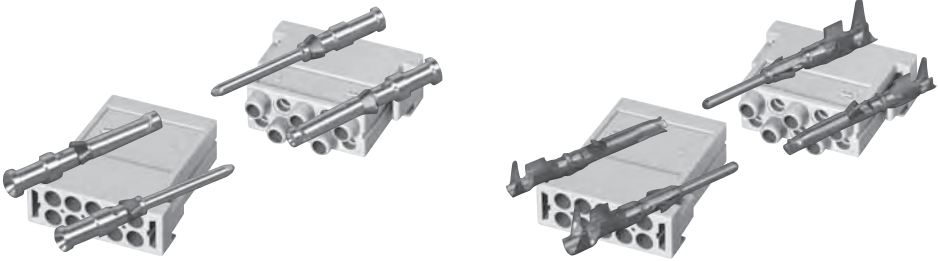
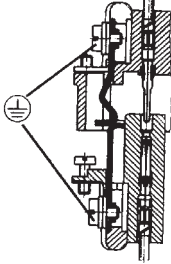

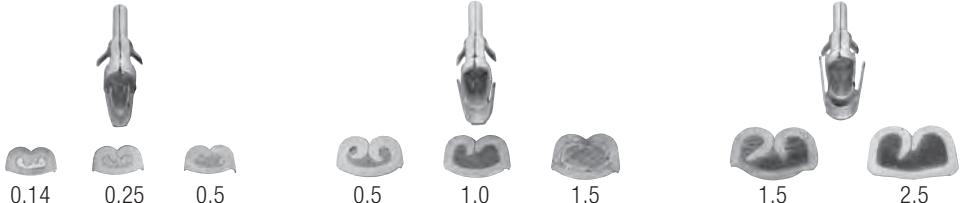

M

<b>Hauptmerkmale</b>		<b>Main characteristics</b>	
<ul style="list-style-type: none"> <li>• Modular aufgebauter Steckverbinder</li> <li>• Bemessungsspannung 63 - 1000 V</li> <li>• Bemessungsstrom 5 A ... 70 A</li> <li>• Anschlussart: crimpen</li> <li>• Polzahl: 3 - 280</li> </ul>		<ul style="list-style-type: none"> <li>• Modular connector</li> <li>• Rated voltage 63 - 1000 V</li> <li>• Rated current 5 A ... 70 A</li> <li>• Termination: crimp</li> <li>• Number of contacts: 3 - 280</li> </ul>	
<b>Zulassungen / Approvals</b>		<b>Zulassungs-Nummer / Approval-No.</b>	
<b>Prüfstelle / Testhouse</b>			
VDE			56 79 ÜG
BGZ		Kennwerte siehe Bemessungsspannung und Bemessungsstrom S. 61	VBG 70
SEV			
UL		Characteristics see rated voltage and rated current page 61	E 63093
CSA			48932
Zulassungen beziehen sich im allgemeinen auf repräsentative Ausführungen der Steckverbinderserie. Prüfumfang und Prüfvorschrift auf Anfrage.		In general approvals refer to representative versions of the connector series. Extent and specification of tests upon request.	

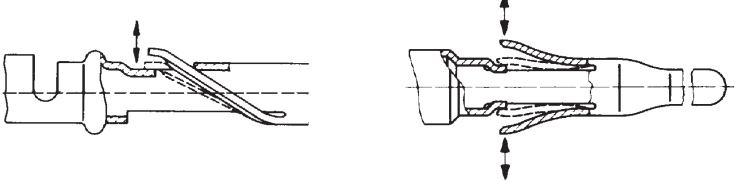
<p>Allgemeine Hinweise</p>  <p>General information</p>	<ul style="list-style-type: none"> <li>• Module ohne Crimpkontakte, Crimpwerkzeuge siehe separater Katalog „Werkzeuge“.</li> <li>• Kontakte müssen separat bestellt werden, Verarbeitungs- und Montagehinweise siehe Katalog „Werkzeuge“.</li> <li>• Für die Einsätze der Serie C 146 M werden die hohen Gehäusebauformen empfohlen.</li> <li>• Steckverbinder der Serie C 146 M dürfen unter Spannung, jedoch nicht unter Strom betätigt werden. Werden die Steckverbinder unter Last gesteckt und getrennt, ist der Strom auf 10 % des Bemessungsstroms zu begrenzen.</li> <li>• Leere Modulplätze sind durch Blindmodule aufzufüllen.</li> <li>• Drehmoment für PE-Anschluss 1,8 Nm</li> </ul> <ul style="list-style-type: none"> <li>• <i>Modules inserts without crimp contacts, crimping tools see separate catalogue „Tools“.</i></li> <li>• <i>Contacts must be ordered separately, processing instructions see catalogue „Tools“.</i></li> <li>• <i>We recommend using the high profile housings / hoods for the C146 M inserts.</i></li> <li>• <i>Connectors series C 146 M may be engaged or disengaged when live but without electrical load.</i></li> <li>• <i>If these connectors are mated or unmated under load, the load shall be reduced to 10 % of rated current.</i></li> <li>• <i>Empty modul spaces have to be filled with blind modules.</i></li> <li>• <i>Torque for PE connection 1,8 Nm</i></li> </ul>
<p>Systemvorteile</p> <p>Advantages of the system</p>	<ul style="list-style-type: none"> <li>• Viele Kombinationsmöglichkeiten</li> <li>• Inverse Bestückung möglich</li> <li>• Bemessungsspannung bis 1000 V</li> <li>• Kostengünstig</li> </ul> <ul style="list-style-type: none"> <li>• <i>High combination possibilities</i></li> <li>• <i>Possibility of inverse configuration</i></li> <li>• <i>Rated voltage up to 1000 V</i></li> <li>• <i>Low cost</i></li> </ul>
<p>Hoher Schutz vor Fehlsteckungen</p> <p>High protection against mismatching</p>	<ul style="list-style-type: none"> <li>• Buchsenkontakteinsatz mit trichterförmiger, verengter Stecköffnung.</li> <li>• Hohe Steck- und Kontaktsicherheit bei 10 pol. Modul mit gestanzten Kontakten.</li> </ul> <ul style="list-style-type: none"> <li>• <i>Female inserts with funnel shaped contact entry avoids mismatching.</i></li> <li>• <i>High security in mating and contacting with stamped crimp contacts for 10 pin module.</i></li> </ul> 
<p>10 pol. Module für gestanzte Kontakte und für gedrehte Kontakte</p> <p>10 pin modules for stamped contacts and for turned contacts</p>	
<p>Voreilender Schutzkontakt Mindest Anschlussquerschnitt 0,5 mm<sup>2</sup></p> <p>First-to-mate last-to-break protective ground contact Minimum wire size 0,5 mm<sup>2</sup></p>	
<p>Große Gehäuseauswahl in 2 Bauhöhen (ab Seite 126)</p> <p>Large range of housings in 2 different heights (see page 126)</p>	



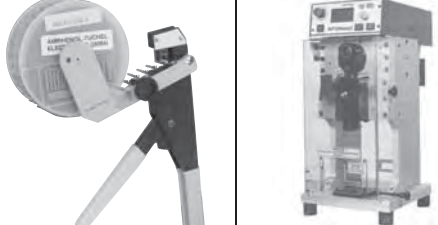
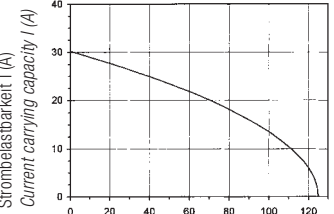
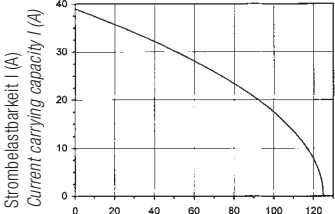



<p>Großer Crimpbereich <i>Large range of wire gauges</i></p> <p>Gasdichte Verbindung (Kaltverschweißung) <i>Gas-tight (coldwelding)</i></p>	<p>.N01 016 0003 (1) <sup>1)</sup>      .N01 016 0002 (1) <sup>1)</sup>      .N01 016 0005 (1) <sup>1)</sup></p>  <p>0,14   0,25   0,5      0,5   1,0   1,5      1,5   2,5</p>		
<p>Gestanzte Crimpkontakte mit Isolierungshalterung um mechanische Beanspruchung von der Crimpverbindung fernzuhalten <i>Stamped crimp contacts with insulation crimp, to absorb mechanical stress from the crimped connection</i></p>	 <p>Isolierungshalterung <i>Insulation grip</i></p>		
<p>Mechanischer Rasthakenanschlag bei Buchsen- und Stiftkontakt <i>Mechanical retention spring stop on female and male contact</i></p> <p>Einfache Montage <i>Easy assembly</i></p>	<p>Buchsenkontakt <i>Female contact</i></p> 	<p>Stiftkontakt <i>Male contact</i></p> 	
<p>Kostengünstige, einfache Verarbeitung Werkzeuge siehe Katalog „Werkzeuge“ <i>Economical and easy processing Tools see catalogue „Tools“</i></p>	 <p>Service-Anwendungen <i>Service application</i></p>	 <p>Einzel-Fertigung <i>Single production</i></p>	 <p>Kleinserie <i>Small series</i></p> <p>Serie <i>Series</i></p>
<p>Hohe Strombelastbarkeit (siehe Derating Kurven) <i>High current carrying capacity (see derating curves)</i></p>	<p>Beispiel Einzelkontakt / <i>Example single contact</i></p> <div style="display: flex; justify-content: space-around;"> <div data-bbox="507 1713 869 2004">  <p>Strombelastbarkeit I (A) <i>Current carrying capacity I (A)</i></p> <p>Bauelement Umgebungstemperatur <math>T_u</math> (°C) <i>Ambient temperature <math>T_{amb}</math> (°C)</i></p> <p>Standardkontakt, Anschlussquerschnitt 2,5 mm<sup>2</sup> <i>Standard contact, wire gauge 2.5 mm<sup>2</sup></i></p> </div> <div data-bbox="1013 1713 1380 2004">  <p>Strombelastbarkeit I (A) <i>Current carrying capacity I (A)</i></p> <p>Bauelement Umgebungstemperatur <math>T_u</math> (°C) <i>Ambient temperature <math>T_{amb}</math> (°C)</i></p> <p>Hochstromkontakt, Anschlussquerschnitt 2,5 mm<sup>2</sup> <i>High current contact, wire gauge 2.5 mm<sup>2</sup></i></p> </div> </div>		

<sup>1)</sup> Erläuterung der Bestell-Nr. für die Kontakte siehe Seite 4

<sup>1)</sup> Explanation of the Part No. of contacts see page 4

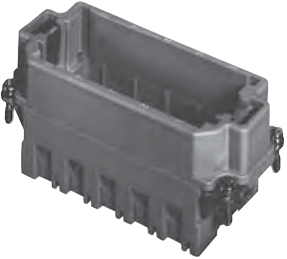
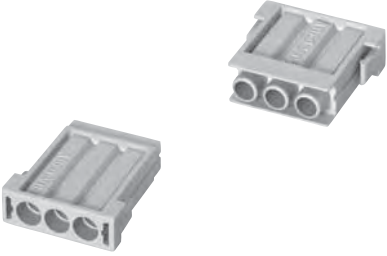
# C 146 M

## Bestellverfahren How to order

Auswahl <i>Choice</i>		Beispiel Bestell Nr. <i>Example Part No.</i>
1) Rahmen <i>Frames</i>		C146 P16 001 G8
2) Module <i>Modules</i>		C146 A03 001 E8
3) Kontakte <i>Contacts</i>		VN01 036 0002 1C
4) Werkzeug <i>Tool</i>		TA 0000 + TA 0000 124 + TA 0010 146 004
5) Gehäuse <i>Housings</i>		C146 10G016 500 8

<b>Allgemeine Kennwerte</b>	<b>General Characteristics</b>									
<b>Modul</b>	<b>Module</b>	<b>1</b>	<b>2</b>	<b>3</b>	<b>4</b>	<b>5</b>	<b>6</b>	<b>7</b>	<b>8</b>	<b>9</b>
Polzahl	<i>Number of contacts</i>	20	10	10 <sup>1)</sup>	5	3	4+⊕/5	3	3	5
Kontakt Durchmesser in mm	<i>Contact diameter in mm</i>	1,0	1,6	1,6	2,5	3,6	2,5	3,6 Koax	3,6	2,5
Crimpkontakt	<i>Crimp contact</i>	gestanzt <i>stamped</i>	gestanzt <i>stamped</i>	gedreht <i>turned</i>	gedreht <i>turned</i>	gedreht <i>turned</i>	gestanzt <i>stamped</i>	gedreht <i>turned</i>	gedreht <i>turned</i>	gedreht <i>turned</i>
Anschlussart	<i>Termination technique</i>	crimpen / <i>crimp</i>								
Brennbarkeit	<i>Flammability</i>	V-0								
<b>Elektrische Kennwerte</b>	<b>Electrical Characteristics</b>									
Bemessungsspannung <sup>2)</sup>	<i>Rated voltage <sup>2)</sup></i>	63 V	400 V	400 V	400 V	630 V	1000 V	250 V	1000 V	400 V
Verschmutzungsgrad <sup>2)</sup>	<i>Pollution degree <sup>2)</sup></i>	3	3	3	3	3	3	3	3	3
Bemessungs-Stoßspannung <sup>2)</sup>	<i>Rated impulse withstand voltage <sup>2)</sup></i>	4,0 kV	6,0 kV	6,0 kV	6,0 kV	8,0 kV	8,0 kV		8,0 kV	6,0 kV
Isolierstoffgruppe <sup>2)</sup> (PA)	<i>Material group <sup>2)</sup> (PA)</i>	II	II	II	II	II	II	II	II	II
Spannungsfestigkeit <sup>3)</sup>	<i>Voltage proof <sup>3)</sup></i>	1680 V	2110 V	2110 V	3510 V	4260 V	5700 V		5700 V	3510 V
Bemessungsstrom $T_u = 40\text{ °C}$	<i>Rated current <math>T_{amb} = 40\text{ °C}</math></i>	5 A	10 A	10 A	20 A	50 A	16 A		50 A	20 A
Strombelastbarkeit <sup>4)</sup>	<i>Current carrying capacity <sup>4)</sup></i>	siehe Derating Kurven / <i>see derating curves</i>								
Isolationswiderstand <sup>3)</sup>	<i>Insulation resistance <sup>3)</sup></i>	$\geq 10^{12}\ \Omega$								
Durchgangswiderstand <sup>3)</sup>	<i>Contact resistance <sup>3)</sup></i>	$< 5\text{ m}\Omega$								
<b>Klimatische Kennwerte</b>	<b>Climatical Characteristics</b>									
Temperaturbereich	<i>Temperatur range</i>	-40 °C - +125 °C	-40 °C +100 °C	- 40 °C / + 125 °C						
<b>Mechanische Kennwerte</b>	<b>Mechanical Characteristics</b>									
Steck- und Ziehkraft <sup>5)</sup>	<i>Insertion and withdrawal forces <sup>5)</sup></i>	15 - 20 N (Rahmen / <i>frame</i> )								
<sup>6)</sup> IP-Schutzart Stifteinsatz	<i>IP-degree of protection pin insert</i>	Norm/Standard IEC 60529				ungesteckt/ <i>unmated</i> IP00			gesteckt/ <i>mated</i> IP20	
<sup>6)</sup> IP-Schutzart Buchseneinsatz	<i>IP-degree of protection socket insert</i>	Norm/Standard IEC 60529				ungesteckt/ <i>unmated</i> IP20			gesteckt/ <i>mated</i> IP20	
<b>Werkstoffe</b>	<b>Materials</b>									
Rahmen	<i>Frames</i>	PA 6.6 GF								
Module	<i>Modules</i>	PA 6.6 GF								
Farbe Rahmen	<i>Colour frames</i>	schwarz / <i>black</i>								
Farbe Module	<i>Colour modules</i>	schwarz / <i>black</i> / rotbraun / <i>redbrown</i>								
Kontakte	<i>Contacts</i>	Cu-Legierung / <i>Cu-alloy</i>								
Kontaktoberfläche	<i>Contact plating</i>	Au	Ag				Au		Ag	

<sup>1)</sup> auch LWL Kontakte möglich 1,0 mm POF / *also FO 1,0 mm contacts available*

<sup>2)</sup> nach IEC 60664-1 / *according to IEC 60664-1*

<sup>3)</sup> nach IEC 60512-2 / *according to IEC 60512-2*

<sup>4)</sup> nach IEC 60512-3 / *according to IEC 60512-3*

<sup>5)</sup> nach IEC 60512-7 / *according to IEC 60512-7*

<sup>6)</sup> Ausnahme Stifteinsatz IP 20 siehe Module / *Exception pin insert IP 20 see modules*

# C 146 M









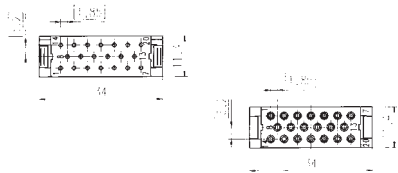

## Module Übersicht Modules Overview

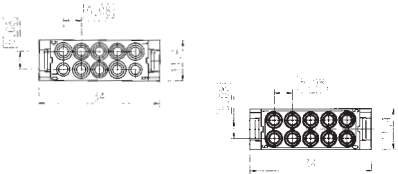

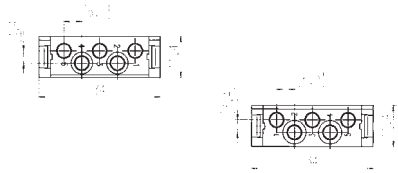
Sittmodul / pin module

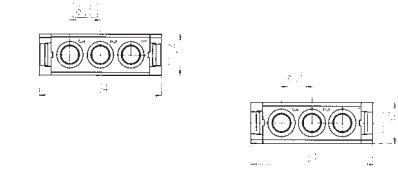
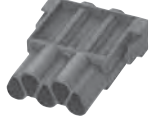
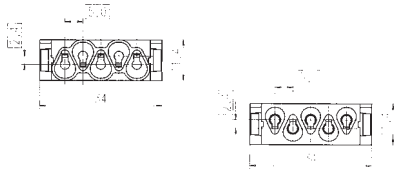

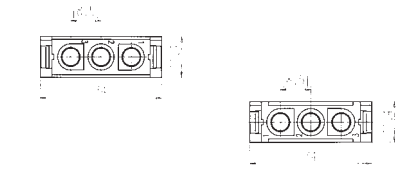
Buchsenmodul / socket module

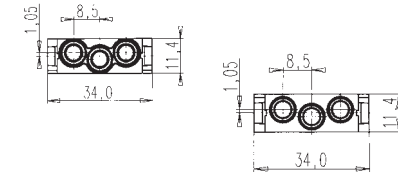
Bezeichnung - Abbildung Description - Figure	Nr. No.	Maßzeichnung Drawing	Bestell Nr. / Part No.	
			Stiftmodule / Pin module	Buchsenmodule / Socket module
20 pol. für gestanzte Kontakte 20 contacts for stamped contacts 	1		C146 A20 001 G8	C146 B20 001 G8
10 pol. für gestanzte Kontakte 10 contacts for stamped contacts 	2		C146 D10 001 E8	C146 C10 001 G8
10 pol. für gedrehte Kontakte 10 contacts for turned contacts 	3		C146 A10 001 E8	C146 B10 001 E8
5 pol. für gedrehte Kontakte 5 contacts for turned contacts 	4		C146 A05 001 E8 <sup>1)</sup>	C146 B05 001 E8 <sup>1)</sup>
3 pol. für gedrehte Kontakte 3 contacts for turned contacts 	5		C146 A03 001 E8	C146 B03 001 E8
5 pol. für gestanzte Kontakte 5 contacts for stamped contacts 	6		C146 D04 001 E8 (4 pol) C146 D05 001 E8 (4 + PE) C146 D05 801 E8 (5 pol)	C146 C04 001 E8 (4 pol) C146 C05 001 E8 (4 + PE) C146 C05 801 E8 (5 pol)
3 pol. für Koax Kontakte 3 contacts for coax contacts 	7		C146 A03 501 E8	C146 B03 501 E8
3 pol. für gedrehte Kontakte 3 contacts for turned contacts 	8		C146 A03 801 E8	C146 B03 801 E8

# C 146 M

## Rahmen Frames



**Gehäuse, siehe Seite 126-153**  
**Housings, see page 126-153**

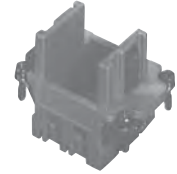

Rahmen für Stiftmodule <sup>1)</sup>  
Frame for pin modules <sup>1)</sup>

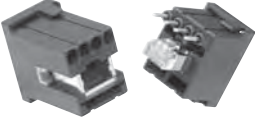
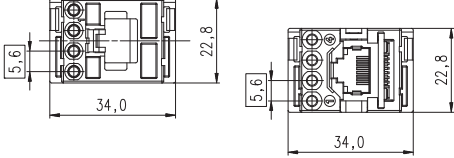
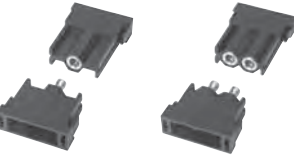
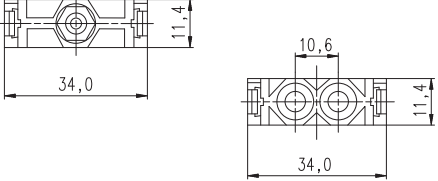
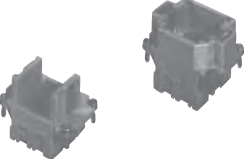
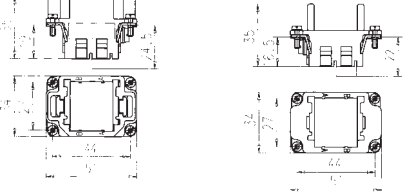
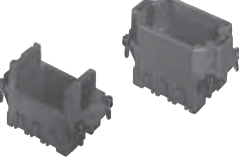
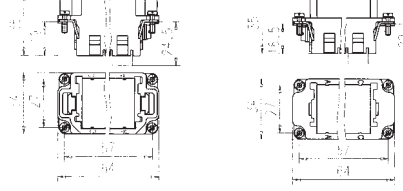
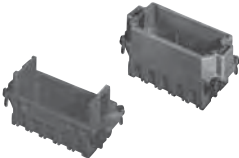
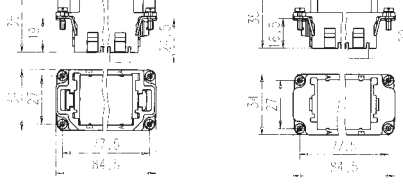

Rahmen für Buchsenmodule <sup>1)</sup>  
Frame for socket modules <sup>1)</sup>

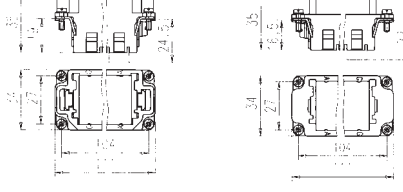
Bezeichnung - Abbildung Description - Figure	Maßzeichnung / Drawing	Bestell Nr. / Part No. <sup>2)</sup>		
		Stiftmodule / pin module	Buchsenmodule/socket modul	
RJ Modul RJ module 		C146 E12 001 E8	C146 F12 001 G8	
Pneu Modul, 1 oder 2 Verbindungen Pneumatic module, 1 or 2 connections 		C146 G01 014 G8 (2,5 mm) C146 G01 024 G8 (4,0 mm)  C146 G02 014 G8 (2,5 mm) C146 G02 024 G8 (4,0 mm)	C146 H01 034 G8 (2,5 mm) C146 H01 044 G8 (4,0 mm)  C146 H02 034 G8 (2,5 mm) C146 H02 044 G8 (4,0 mm)	
Bezeichnung - Abbildung Description - Figure	Maßzeichnung / Drawing	Kennzeich. Positions	Bestell Nr. / Part No. <sup>2)</sup>	
	Rahmen für Stiftmodule Frame for pin modules		Rahmen für Buchsenmodule Frame for socket module	Rahmen für Stiftmodule Frame for pin modules
Rahmen für 2 Module Frame for 2 modules 		A - B	C146 P06 001 G8  C146 P06 002 G8 (2 x PE)	C146 S06 001 G8  C146 S06 002 G8 (2 x PE)
Rahmen für 3 Module Frame for 3 modules 		A - C	C146 P10 001 G8  C146 P10 002 G8 (2 x PE)	C146 S10 001 G8  C146 S10 002 G8 (2 x PE)
Rahmen für 5 Module Frame for 5 modules 		A - E	C146 P16 001 G8  C146 P16 002 G8 (2 x PE)	C146 S16 001 G8  C146 S16 002 G8 (2 x PE)
Rahmen für 7 Module Frame for 7 modules 		A - G  T - Z	C146 P24 001 G8 C146 P24 002 G8 (2 x PE)  C146 P24 101 G8 C146 P24 102 G8 (2 x PE)	C146 S24 001 G8 C146 S24 002 G8 (2 x PE)  C146 S24 101 G8 C146 S24 102 G8 (2 x PE)

<sup>1)</sup> Im Rahmen für Stiftmodule können auch Buchsenmodule gesteckt werden (inverse Bestückung möglich).

<sup>1)</sup> It is possible to mount socket modules in frames for pin modules (possibility of inverse configuration).

<sup>2)</sup> Für den Einbau der Steckverbinder in nicht leitende Gehäuse sind beide Schutzleiter (Ausführung 2 x PE) anzuschließen.

<sup>2)</sup> If connectors are mounted in non conductive housings both protective earthing terminals shall be mounted.



# C 146 M

## 20 pol

### Technische Daten Characteristics

Allgemeine Kennwerte	General Characteristics	Norm / Standard	Wert / Value
Polzahl	Number of contacts		20
Anschluss technik	Termination technique		crimpen / crimp
Anschlussquerschnitt	Wire gauge		0,09 - 0,5 mm <sup>2</sup> (AWG 28 - 20)
Brennbarkeit	Flammability	UL 94	V-0
Elektrische Kennwerte	Electrical Characteristics		
Bemessungsspannung	Rated voltage	IEC 60664-1	63 V
Verschmutzungsgrad	Pollution degree	IEC 60664-1	3
Überspannungskategorie	Installation (overvoltage) category	IEC 60664-1	III
Isolierstoffgruppe	Material group	IEC 60664-1	II (PA)
Bemessungs-Stoßspannung	Rated impulse withstand voltage	IEC 60664-1	4,0 kV
Spannungsfestigkeit	Voltage proof	IEC 60512-2; Test 4 a	1,68 kV
Strombelastbarkeit	Current carrying capacity	IEC 60512-3; Test 5 b	siehe Derating Kurven / see derating curves
Durchgangswiderstand	Contact resistance	IEC 60512-2; Test 2 a	≤ 5 mΩ
Isolationswiderstand	Insulation resistance	IEC 60512-2; Test 3 a	≥ 10 <sup>12</sup> Ω <sup>2)</sup>
Luftstrecke	Clearance	IEC 60664-1	> 2,4 mm
Kriechstrecke	Creepage	IEC 60664-1	> 2,4 mm
Klimatische Kennwerte	Climatical Characteristics		
Prüfklasse	Climatic category	IEC 60068-1	40 / 125 / 21
Obere Grenztemperatur	Upper temperature	IEC 60512-6; Test 11 i	+ 125 °C / 1000 h
Untere Grenztemperatur	Lower temperature	IEC 60512-6; Test 11 i	- 40 °C
Mechanische Kennwerte	Mechanical Characteristics		
Steck- und Ziehkraft <sup>1)</sup>	Insertion and withdrawal forces <sup>1)</sup>	IEC 60512-7; Test 13 b	10 - 15 N
Mechanische Lebensdauer	Mechanical operation	IEC 60512-5; Test 9 a	≥ 500 Steckzyklen / mating cycles
Werkstoffe	Materials		
Kontakteinsatz	Insert		PA 6.6 GF
Farbe	Colour		schwarz / black
Kontakte Stift / Buchse	Contacts male / female		CuZn (Messing/brass) / CuSn (Bronze/bronze)
Kontakt oberfläche	Contact plating		Au (gold / gold)

<sup>1)</sup> für ein Modul / for one module

<sup>2)</sup> bei Beanspruchung >10<sup>10</sup> Ω / under operating condition >10<sup>10</sup> Ω

#### Derating Kurven / Derating curves

0,25 mm<sup>2</sup>

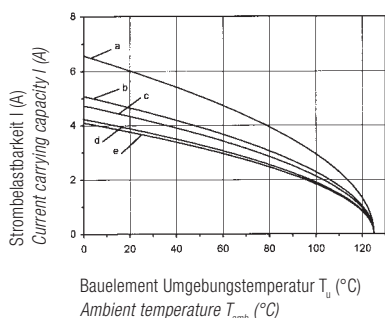

0,5 mm<sup>2</sup>

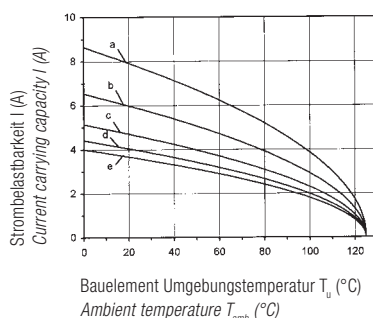

Kurve Curve	Polzahl Contacts	Rahmen Frame
a	20	2 Module
b	40	2 Module
c	60	3 Module
d	100	5 Module
e	140	7 Module

# C 146 M 20 pol

Module  
Modules



Bandkontakte für Crimpzangen  
Contacts on reel for hand crimping tools



350 Stück  
350 pcs

Bandkontakte für Crimpmaschinen  
Contacts on reel for crimp machines



2000 Stück  
(Zuführung links)  
2000 pcs  
(feeding left hand side)

für gestanzte 1,0 mm Kontakte  
for stamped 1,0 mm contacts

Abbildung Figure	Maßzeichnung / Drawing		Bestell Nr. / Part No.	
	Stiftmodul / Pin module	Buchsenmodul / Socket module	Stiftmodul / Pin module	Buchsenmodul / Socket module
			C146 A20 001 G8	C146 B20 001 G8

## Crimpkontakte / Crimp contacts

Lieferform Supplied as	für Leiterquerschnitt for wire gauge	AWG	Stückzahl Pieces	Bestell Nr. / Part No.	
				Stiftkontakt / Male contact	Buchsenkontakt / Female contact
Einzelkontakte für Crimpzangen / single contacts for hand crimping tools					
vergoldet / gold plating					
	0,09 - 0,25 mm <sup>2</sup>	28 - 24	100	VN01 010 0130 (2)	VN02 010 0130 (2)
	0,25 - 0,50 mm <sup>2</sup>	24 - 20	100	VN01 010 0131 (2)	VN02 010 0131 (2)
Bandkontakte für Crimpzangen / Contacts on reel for hand crimping tools					
	0,09 - 0,25 mm <sup>2</sup>	28 - 24	500	ZN01 010 0130 (2)	ZN02 010 0130 (2)
	0,25 - 0,50 mm <sup>2</sup>	24 - 20	500	ZN01 010 0131 (2)	ZN02 010 0131 (2)
Bandkontakte für Crimpmaschinen/ Contacts on reel for crimp machines					
Kontaktzuführung links Contact feeding left hand side	0,09 - 0,25 mm <sup>2</sup>	28 - 24	2000	TN01 010 0130 (2)	TN02 010 0130 (2)
	0,25 - 0,50 mm <sup>2</sup>	24 - 20	2000	TN01 010 0131 (2)	TN02 010 0131 (2)
	0,09 - 0,25 mm <sup>2</sup>	28 - 24	10.000	FN01 010 0130 (2)	FN02 010 0130 (2)
	0,25 - 0,50 mm <sup>2</sup>	24 - 20	10.000	FN01 010 0131 (2)	FN02 010 0131 (2)

## Werkzeuge / Tools <sup>1)</sup>

Bezeichnung / Description	für Leiterquerschnitt for wire gauge	Kontaktaufnahme / Contact locator	Crimpbacken / Crimping dies	Bestell Nr. / Part No.
				Werkzeuge / Tools
Lösewerkzeug für Kontakte Removal tool for contacts	–	–	–	17D 438 SP
Lösewerkzeug für Module Removal tool for modules	–	–	–	FG 1000 146
Service Crimpzange Service crimping tool	0,09 - 0,25 mm <sup>2</sup>	–	–	TA 0200 146
	0,25 - 0,50 mm <sup>2</sup>	–	–	

Bei kleinen Leiterquerschnitten wird der Einsatz von Führungselementen empfohlen (siehe Seite 184)  
If small wire sizes are used, guide pins and guide sockets should be preferred to use (see page 184)

<sup>1)</sup> Weitere Informationen siehe Katalog „Werkzeuge“ / Further information see catalogue „Tools“

Abisolierlängen siehe S. 198  
Stripping length see p. 198

# C 146 M

# 10 pol

## Technische Daten Characteristics

## Module für gestanzte Kontakte Modules for stamped contacts

Allgemeine Kennwerte	General Characteristics	Norm / Standard	Wert / Value
Polzahl	Number of contacts		10
Anschluss technik	Termination technique		crimpen / crimp
Anschlussquerschnitt	Wire gauge		0,14 - 2,5 mm <sup>2</sup> (AWG 26 - 14)
Brennbarkeit	Flammability	UL 94	V-0
Elektrische Kennwerte	Electrical Characteristics		
Bemessungsspannung	Rated voltage	IEC 60664-1	400 V
Verschmutzungsgrad	Pollution degree	IEC 60664-1	3
Überspannungskategorie	Installation (overvoltage) category	IEC 60664-1	III
Isolierstoffgruppe	Material group	IEC 60664-1	II
Bemessungs-Stoßspannung	Rated impulse withstand voltage	IEC 60664-1	6,0 kV
Spannungsfestigkeit	Voltage proof	IEC 60512-2; Test 4 a	2,11 kV
Strombelastbarkeit	Current carrying capacity	IEC 60512-3; Test 5 b	siehe Derating Kurven / see derating curves
Durchgangswiderstand	Contact resistance	IEC 60512-2; Test 2 a	≤ 5 mΩ
Isolationswiderstand	Insulation resistance	IEC 60512-2; Test 3 a	≥ 10 <sup>12</sup> Ω <sup>2)</sup>
Luftstrecke / Kriechstrecke	Clearance / Creepage	IEC 60664-1	> 4,3 mm
Klimatische Kennwerte	Climatical Characteristics		
Prüfklasse	Climatic category	IEC 60068-1	40 / 125 / 21
Obere Grenztemperatur	Upper temperature	IEC 60512-6; Test 11 i	+ 125 °C / 1000 h
Untere Grenztemperatur	Lower temperature	IEC 60512-6; Test 11 i	- 40 °C
Mechanische Kennwerte	Mechanical Characteristics		
Steck- und Ziehkraft <sup>1)</sup>	Insertion and withdrawal forces <sup>1)</sup>	IEC 60512-7; Test 13 b	20 - 25 N
Mechanische Lebensdauer	Mechanical operation	IEC 60512-5; Test 9 a	≥ 500 Steckzyklen / mating cycles
Werkstoffe	Materials		
Modul	Module		PA 6.6 GF
Farbe	Colour		schwarz / black
Stiftkontakt	Male contact		CuZn (Messing/brass)
Buchsenkontakt	Female contact		CuSn (Bronze/bronze)
Kontaktoberfläche	Contact plating		Ag (silber/silver)

<sup>1)</sup> für ein Modul / for one module

<sup>2)</sup> bei Beanspruchung >10<sup>10</sup> Ω / under operating condition >10<sup>10</sup> Ω

### Derating Kurven / Derating curves

#### 0,5 mm<sup>2</sup>

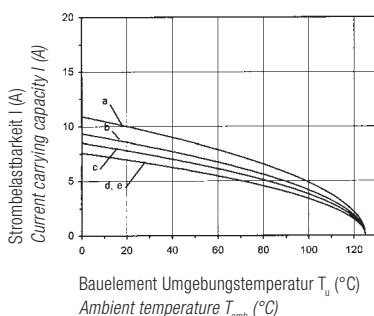

#### 1,5 mm<sup>2</sup>

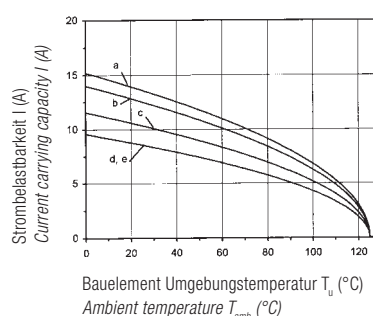

Kurve Curve	Polzahl Contacts	Rahmen Frame
a	10	2 Module
b	20	2 Module
c	30	3 Module
d	50	5 Module
e	70	7 Module

# C 146 M 10 pol

Module  
Modules

gestanzte Einzelkontakte  
Stamped single contacts



Bandkontakte für Crimpzangen  
Contacts on reel for hand crimping tools



200 / 100 Stück  
200 / 100 pcs

Bandkontakte für Crimpmaschinen  
Contacts on reel for crimp machines



2000 Stück  
(Zuführung links  
oder rechts)  
2000 pcs  
(feeding left or  
right hand side)

für gestanzte 1,6 mm Kontakte  
for stamped 1,6 mm contacts

Abbildung Figure	Maßzeichnung / Drawing		Bestell Nr. / Part No.	
	Stiftmodul / Pin module	Buchsenmodul / Socket module	Stiftmodul / Pin module	Buchsenmodul / Socket module
			C146 D10 001 E8	C146 C10 001 G8

## Crimpkontakte / Crimp contacts

Lieferform Supplied as	für Leiterquerschnitt for wire gauge	AWG	Stückzahl Pieces	Bestell Nr. <sup>1)</sup>		Part No. <sup>1)</sup>	
				Stiftkontakt Male contact	Buchsenkontakt Female contact	Stiftkontakt Male contact	Buchsenkontakt Female contact
Gestanzte Einzelkontakte / Stamped single contacts				versilbert / silver plating		vergoldet / gold plating	
Standard Hochstrom High current	0,14 - 0,5 mm <sup>2</sup>	26 - 20	100	VN01 016 0003 (1)	VN02 016 0003 (1)	VN01 016 0003 (2)	VN02 016 0003 (2)
	0,5 - 1,5 mm <sup>2</sup>	20 - 16	100	VN01 016 0002 (1)	VN02 016 0002 (1)	VN01 016 0002 (2)	VN02 016 0002 (2)
	1,5 - 2,5 mm <sup>2</sup>	16 - 14	100	VN01 016 0005 (1)	VN02 016 0005 (1)	VN01 016 0005 (2)	VN02 016 0005 (2)
	0,5 - 1,5 mm <sup>2</sup>	20 - 16	100	VN01 016 0015 (1)	VN02 016 0015 (1)		
	1,5 - 2,5 mm <sup>2</sup>	16 - 14	100	VN01 016 0016 (1)	VN02 016 0016 (1)		
Gestanzte Bandkontakte für Crimpzangen / Stamped Contacts on reel for hand crimp tools							
Standard Hochstrom High current	0,14 - 0,5 mm <sup>2</sup>	26 - 20	200	ZN01 016 0003 (1)	ZN02 016 0003 (1)	ZN01 016 0003 (2)	ZN02 016 0003 (2)
	0,5 - 1,5 mm <sup>2</sup>	20 - 16	200	ZN01 016 0002 (1)	ZN02 016 0002 (1)	ZN01 016 0002 (2)	ZN02 016 0002 (2)
	1,5 - 2,5 mm <sup>2</sup>	16 - 14	100	ZN01 016 0005 (1)	ZN02 016 0005 (1)	ZN01 016 0005 (2)	ZN02 016 0005 (2)
	0,5 - 1,5 mm <sup>2</sup>	20 - 16	200	ZN01 016 0015 (1)	ZN02 016 0015 (1)		
	1,5 - 2,5 mm <sup>2</sup>	16 - 14	100	ZN01 016 0016 (1)	ZN02 016 0016 (1)		
Gestanzte Bandkontakte für Crimpmaschinen / Stamped contacts on reel for crimp machines							
Kontaktzuführung rechts Contact feeding right hand side	0,14 - 0,5 mm <sup>2</sup>	26 - 20	2000	HN01 016 0003 (1)	HN02 016 0003 (1)	HN01 016 0003 (2)	HN02 016 0003 (2)
	0,5 - 1,5 mm <sup>2</sup>	20 - 16	2000	HN01 016 0002 (1)	HN02 016 0002 (1)	HN01 016 0002 (2)	HN02 016 0002 (2)
	Standard 1,5 - 2,5 mm <sup>2</sup>	16 - 14	2000	HN01 016 0005 (1)	HN02 016 0005 (1)	HN01 016 0005 (2)	HN02 016 0005 (2)
	Hochstrom High current 0,5 - 1,5 mm <sup>2</sup>	20 - 16	2000	HN01 016 0015 (1)	HN02 016 0015 (1)		
	1,5 - 2,5 mm <sup>2</sup>	16 - 14	2000	HN01 016 0016 (1)	HN02 016 0016 (1)		
Kontaktzuführung links Contact feeding left hand side	0,14 - 0,5 mm <sup>2</sup>	26 - 20	2000	TN01 016 0003 (1)	TN02 016 0003 (1)	TN01 016 0003 (2)	TN02 016 0003 (2)
	0,5 - 1,5 mm <sup>2</sup>	20 - 16	2000	TN01 016 0002 (1)	TN02 016 0002 (1)	TN01 016 0002 (2)	TN02 016 0002 (2)
	Standard 1,5 - 2,5 mm <sup>2</sup>	16 - 14	2000	TN01 016 0005 (1)	TN02 016 0005 (1)	TN01 016 0005 (2)	TN02 016 0005 (2)
	Hochstrom High current 0,5 - 1,5 mm <sup>2</sup>	20 - 16	2000	TN01 016 0015 (1)	TN02 016 0015 (1)		
	1,5 - 2,5 mm <sup>2</sup>	18 - 14	2000	TN01 016 0016 (1)	TN02 016 0016 (1)		

## Werkzeuge / Tools <sup>2)</sup>

Bezeichnung / Description	für Leiterquerschnitt for wire gauge	Bestell Nr. / Part No.		
		Kontaktaufnahme / Contact locator	Crimpbacken / Crimping dies	Werkzeuge / Tools
Lösewerkzeug für Kontakte / Module Removal tool for contacts / modules	–	–	–	FG 0300 146 1 / FG 1000 146
Service Crimpzange Service crimping tool	0,14 - 0,5 mm <sup>2</sup> 0,5 - 1,5 mm <sup>2</sup>	–	–	TA 0100 146
Crimpzange für Einzelkontakte Crimping tool for single contacts	0,14 - 0,5 mm <sup>2</sup>	TA 0001 146 000 1	TA 0000 202	TA 0000
	0,5 - 1,5 mm <sup>2</sup>	TA 0002 146 000 1	TA 0000 163	
	1,5 - 2,5 mm <sup>2</sup>	TA 0007 146 000 3	TA 0000 141	

<sup>1)</sup> Erläuterung der Bestell-Nr. für die Kontakte siehe Seite 4 / Explanation of the Part No. for contacts see page 4

<sup>2)</sup> Weitere Informationen siehe Katalog „Werkzeuge“ / Further information see catalogue „Tools“

Abisolierlängen siehe S. 198  
Stripping length see p. 198

# C 146 M 10 pol

## Technische Daten Characteristics

## für gedrehte 1,6 mm Kontakte for turned 1,6 mm contacts

Allgemeine Kennwerte	General Characteristics	Norm / Standard	Wert / Value
Polzahl	Number of contacts		10
Anschluss technik	Termination technique		crimpen / crimp
Anschlussquerschnitt	Wire gauge		0,14 - 2,5 mm <sup>2</sup> (AWG 26 - 14)
Brennbarkeit	Flammability	UL 94	V-0
Elektrische Kennwerte	Electrical Characteristics		
Bemessungsspannung	Rated voltage	IEC 60664-1	400 V
Verschmutzungsgrad	Pollution degree	IEC 60664-1	3
Überspannungskategorie	Installation (overvoltage) category	IEC 60664-1	III
Isolierstoffgruppe	Material group	IEC 60664-1	II (PA)
Bemessungs-Stoßspannung	Rated impulse withstand voltage	IEC 60664-1	6,0 kV
Spannungsfestigkeit	Voltage proof	IEC 60512-2; Test 4 a	2,21 kV
Strombelastbarkeit	Current carrying capacity	IEC 60512-3; Test 5 b	siehe Derating Kurven / see derating curves
Durchgangswiderstand	Contact resistance	IEC 60512-2; Test 2 a	≤ 5 mΩ
Isolationswiderstand	Insulation resistance	IEC 60512-2; Test 3 a	≥ 10 <sup>12</sup> Ω <sup>2)</sup>
Luftstrecke	Clearance	IEC 60664-1	> 4,3 mm
Kriechstrecke	Creepage	IEC 60664-1	> 4,3 mm
Klimatische Kennwerte	Climatical Characteristics		
Prüfklasse	Climatic category	IEC 60068-1	40 / 100 / 21
Obere Grenztemperatur	Upper temperature	IEC 60512-6; Test 11 i	+ 100 °C / 1000 h
Untere Grenztemperatur	Lower temperature	IEC 60512-6; Test 11 i	- 40 °C
Mechanische Kennwerte	Mechanical Characteristics		
Steck- und Ziehkraft <sup>1)</sup>	Insertion and withdrawal forces <sup>1)</sup>	IEC 60512-7; Test 13 b	25 - 30 N
Mechanische Lebensdauer	Mechanical operation	IEC 60512-5; Test 9 a	≥ 500 Steckzyklen / mating cycles
Werkstoffe	Materials		
Modul	Module		PA 6.6 GF
Farbe	Colour		schwarz / black
Kontakte	Contacts		CuZn (Messing / brass)
Kontaktoberfläche	Contact plating		Ag (silber / silver)

<sup>1)</sup> für ein Modul / for one module

<sup>2)</sup> bei Beanspruchung >10<sup>10</sup> Ω / under operating condition >10<sup>10</sup> Ω

### Derating Kurven / Derating curves

#### 0,5 mm<sup>2</sup>

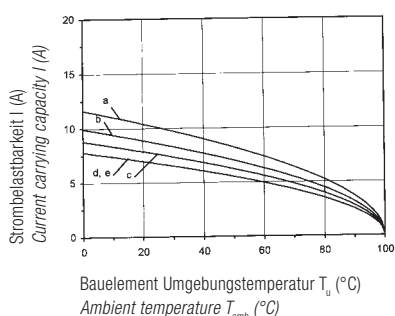

#### 1,5 mm<sup>2</sup>

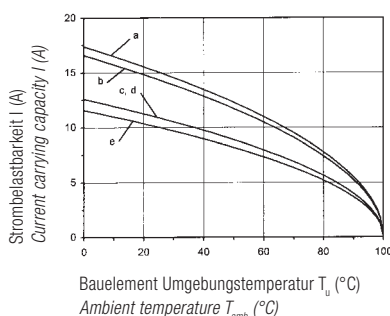

Kurve Curve	Polzahl Contacts	Rahmen Frame
a	10	2 Module
b	20	2 Module
c	30	3 Module
d	50	5 Module
e	70	7 Module



# C 146 M 10 pol

Module  
Modules

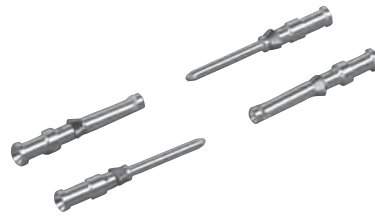

für gedrehte 1,6 mm Kontakte  
for turned 1,6 mm contacts



LWL-Kontakte  
FO-contacts

Abbildung Figure	Maßzeichnung / Drawing Stiftmodul / Pin module    Buchsenmodul / Socket module	Bestell Nr. / Part No.	
		Stiftmodul / Pin module	Buchsenmodul / Socket module
		C146 A10 001 E8	C146 B10 001 E8

## Crimpkontakte / Crimp contacts

Lieferform Supplied as	für Leiterquerschnitt for wire gauge	AWG	Stückzahl Pieces	Bestell Nr. <sup>1)</sup> / Part No. <sup>1)</sup>			
				Stiftkontakt Male contact	Buchsenkontakt Female contact		
Gedrehte Crimpkontakte / Turned crimp contacts				versilbert / silver plating		vergoldet / gold plating	
Einzelkontakte Single contact	0,14 - 0,37mm <sup>2</sup>	26 - 22	100	VN01 016 0024 (1)C	VN02 016 0024 (1)C	VN01 016 0024 (2)C	VN02 016 0024 (2)C
	0,5 mm <sup>2</sup>	20	100	VN01 016 0025 (1)C	VN02 016 0025 (1)C	VN01 016 0025 (2)C	VN02 016 0025 (2)C
	0,75 - 1,0 mm <sup>2</sup>	20 - 16	100	VN01 016 0026 (1)C	VN02 016 0026 (1)C	VN01 016 0026 (2)C	VN02 016 0026 (2)C
	1,5 mm <sup>2</sup>	16 - 15	100	VN01 016 0027 (1)C	VN02 016 0027 (1)C	VN01 016 0027 (2)C	VN02 016 0027 (2)C
	2,5 mm <sup>2</sup>	14	100	VN01 016 0028 (1)C	VN02 016 0028 (1)C	VN01 016 0028 (2)C	VN02 016 0028 (2)C

## LWL Kontakte / FO contacts

Lieferform Supplied as	für Leiterquerschnitt for wire gauge	AWG	Stückzahl Pieces	Bestell Nr. <sup>1)</sup> / Part No. <sup>1)</sup>	
				Stiftkontakt / Male contact	Buchsenkontakt / Female contact
Crimpkontakte / Crimp contacts					
Einzelkontakt / Single contact	1,0 mm POF/FO	–	10	VN01 016 0040 (8) X	VN02 016 0040 (8) X

## Werkzeuge / Tools<sup>2)</sup>

Bezeichnung / Description	für Leiterquerschnitt for wire gauge	Kontaktaufnahme / Contact locator	Bestell Nr. / Part No.	
			Crimpbacken / crimping dies	Werkzeuge / Tools
Lösewerkzeug für Kontakte Removal tool for contacts	–	–	–	FG 0300 146 1
Lösewerkzeug für Module Removal tool for modules	–	–	–	FG 1000 146
Crimpzange für Einzelkontakte Crimping tool for single contacts	0,14 - 1,0 mm <sup>2</sup> 1,5 mm <sup>2</sup> 2,5 mm <sup>2</sup>	TA 0010 146 000 1	TA 0000 184	TA 0000
Crimpzange für LWL Kontakte <sup>3)</sup> Crimping tool for FO contacts <sup>3)</sup>	1,0 mm POF/FO			TB 0500 146

<sup>1)</sup> Erläuterung der Bestell-Nr. für die Kontakte siehe Seite 4 / Explanation of the Part No. for contacts see page 4

<sup>2)</sup> Weitere Informationen siehe Katalog „Werkzeuge“ / Further information see catalogue „Tools“

<sup>3)</sup> incl. Abisolierwerkzeug, Kontaktaufnahme, Schleiflehre / incl. stripping tool, locator, abrasive adapter

Abisolierlängen siehe S. 198  
Stripping length see p. 198

# C 146 M

## 5 pol

### Technische Daten Characteristics

Allgemeine Kennwerte	General Characteristics	Norm / Standard	Wert / Value
Polzahl	Number of contacts		5
Anschluss technik	Termination technique		crimpen / crimp
Anschlussquerschnitt	Wire gauge		0,5 - 4,0 mm <sup>2</sup> (AWG 20 - 12)
Brennbarkeit	Flammability	UL 94	V-0
Elektrische Kennwerte	Electrical Characteristics		
Bemessungsspannung	Rated voltage	IEC 60664-1	400 V
Verschmutzungsgrad	Pollution degree	IEC 60664-1	3
Überspannungskategorie	Installation (overvoltage) category	IEC 60664-1	III
Isolierstoffgruppe	Material group	IEC 60664-1	II
Bemessungs-Stoßspannung	Rated impulse withstand voltage	IEC 60664-1	6,0 kV
Spannungsfestigkeit	Voltage proof	IEC 60512-2; Test 4 a	3,51 kV
Strombelastbarkeit	Current carrying capacity	IEC 60512-3; Test 5 b	siehe Derating Kurven / see derating curves
Durchgangswiderstand	Contact resistance	IEC 60512-2; Test 2 a	≤ 2 mΩ
Isolationswiderstand	Insulation resistance	IEC 60512-2; Test 3 a	≥ 10 <sup>12</sup> Ω <sup>2)</sup>
Luftstrecke	Clearance	IEC 60664-1	5,8 mm
Kriechstrecke	Creepage	IEC 60664-1	5,8 mm
Klimatische Kennwerte	Climatical Characteristics		
Prüfklasse	Climatic category	IEC 60068-1	40 / 125 / 21
Obere Grenztemperatur	Upper temperature	IEC 60512-6; Test 11 i	+ 125 °C / 1000 h
Untere Grenztemperatur	Lower temperature	IEC 60512-6; Test 11 i	- 40 °C
Mechanische Kennwerte	Mechanical Characteristics		
Steck- und Ziehkraft <sup>1)</sup>	Insertion and withdrawal forces <sup>1)</sup>	IEC 60512-7; Test 13 b	25 - 30 N
Mechanische Lebensdauer	Mechanical operation	IEC 60512-5; Test 9 a	≥ 500 Steckzyklen / mating cycles
Werkstoffe	Materials		
Modul	Module		PA 6.6 GF
Farbe	Colour		schwarz
Kontakte	Contacts		Cu-Legierung / Cu-alloy
Kontaktoberfläche	Contact plating		Ag (silber / silver)

<sup>1)</sup> für ein Modul / for one module

<sup>2)</sup> bei Beanspruchung >10<sup>10</sup> Ω / under operating condition >10<sup>10</sup> Ω

#### Derating Kurven / Derating curves

##### 2,5 mm<sup>2</sup>

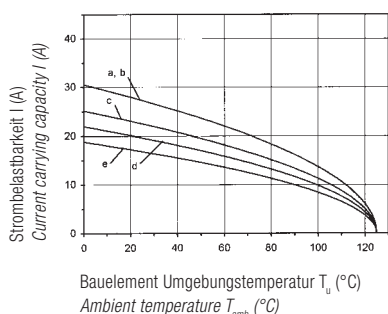

##### 4 mm<sup>2</sup>

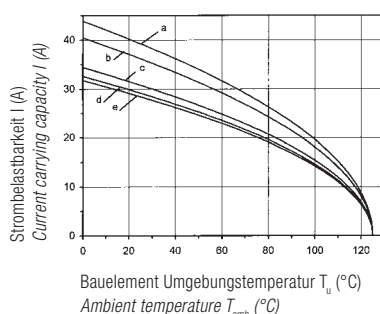

Kurve Curve	Polzahl Contacts	Rahmen Frame
a	5	2 Module
b	10	2 Module
c	15	3 Module
d	25	5 Module
e	35	7 Module

# C 146 M 5 pol

Module  
Modules

für gedrehte 2,5 mm Kontakte  
for turned 2,5 mm contacts



Abbildung Figure	Maßzeichnung / Drawing		Bestell Nr. / Part No.	
	Stiftmodul / Pin module	Buchsenmodul / Socket module	Stiftmodul / Pin module	Buchsenmodul / Socket module
			C146 A05 001 E8	C146 B05 001 E8

## Gedrehte Crimpkontakte / Turned crimp contacts

Lieferform Supplied as	für Leiter- querschnitt for wire gauge	AWG	Stück- zahl Pieces	Bestell Nr. <sup>1)</sup>		Bestell Nr. <sup>1)</sup>	
				Stiftkontakt Male contact	Buchsenkontakt Female contact	Stiftkontakt Male contact	Buchsenkontakt Female contact
Gedrehte Crimpkontakte / Turned crimp contacts				versilbert / silver plating		vergoldet / gold plating	
Einzelkontakte Single contact	0,5 mm <sup>2</sup>	20	100	VN01 025 0029 (1)C	VN02 025 0029 (1)C	VN01 025 0029 (2)C	VN02 025 0029 (2)C
	0,75 - 1,0 mm <sup>2</sup>	18	100	VN01 025 0030 (1)C	VN02 025 0030 (1)C	VN01 025 0030 (2)C	VN02 025 0030 (2)C
	1,5 mm <sup>2</sup>	16	100	VN01 025 0031 (1)C	VN02 025 0031 (1)C	VN01 025 0031 (2)C	VN02 025 0031 (2)C
	2,5 mm <sup>2</sup>	14	100	VN01 025 0032 (1)C	VN02 025 0032 (1)C	VN01 025 0032 (2)C	VN02 025 0032 (2)C
	4,0 mm <sup>2</sup>	12	100	VN01 025 0033 (1)C	VN02 025 0033 (1)C	VN01 025 0033 (2)C	VN02 025 0033 (2)C

## Werkzeuge / Tools<sup>2)</sup>

Bezeichnung / Description	für Leiterquerschnitt for wire gauge	Bestell Nr. / Part No.		
		Kontaktaufnahme / Contact locator	Crimpbacken / crimping dies	Werkzeuge / Tools
Löswerkzeug für Kontakte Removal tool for contacts	–	–	–	FG 0300 146 4
Löswerkzeug für Module Removal tool for modules	–	–	–	FG 1000 146
Crimpzange für Einzelkontakte Crimping tool for single contacts	0,5 - 2,5 mm <sup>2</sup> 4,0 mm <sup>2</sup>	TA 0010 146 000 2 TA 0010 146 000 3	TA 0000 144 TA 0000 124	TA 0000

<sup>1)</sup> Erläuterung der Bestell-Nr. für die Kontakte siehe Seite 4 / Explanation of the Part No. for contacts see page 4

<sup>2)</sup> Weitere Informationen siehe Katalog „Werkzeuge“ / further information see catalogue „Tools“

Abisolierlängen siehe S. 198  
Stripping length see p. 198

# C 146 M

## 3 pol

### Technische Daten Characteristics

Allgemeine Kennwerte	General Characteristics	Norm / Standard	Wert / Value
Polzahl	Number of contacts		3
Anschluss technik	Termination technique		crimpen / crimp
Anschlussquerschnitt	Wire gauge		1,5 - 10 mm <sup>2</sup> (AWG 16 - 8)
Brennbarkeit	Flammability	UL 94	V-0
Elektrische Kennwerte	Electrical Characteristics		
Bemessungsspannung	Rated voltage	IEC 60664-1	630 V
Verschmutzungsgrad	Pollution degree	IEC 60664-1	3
Überspannungskategorie	Installation (overvoltage) category	IEC 60664-1	III
Isolierstoffgruppe	Material group	IEC 60664-1	II (PA)
Bemessungs-Stoßspannung	Rated impulse withstand voltage	IEC 60664-1	8,0 kV
Spannungsfestigkeit	Voltage proof	IEC 60512-2 Test 4 a	4,26 kV
Strombelastbarkeit	Current carrying capacity	IEC 60512-3; Test 5 b	siehe Derating Kurven / see derating curves
Durchgangswiderstand	Contact resistance	IEC 60512-2; Test 2 a	≤ 1 mΩ
Isolationswiderstand	Insulation resistance	IEC 60512-2; Test 3 a	≥ 10 <sup>12</sup> Ω <sup>2)</sup>
Luftstrecke	Clearance	IEC 60664-1	> 12 mm
Kriechstrecke	Creepage	IEC 60664-1	> 12 mm
Klimatische Kennwerte	Climatical Characteristics		
Prüfklasse	Climatic category	IEC 60068-1	40 / 125 / 21
Obere Grenztemperatur	Upper temperature	IEC 60512-6; Test 11 i	+ 125 °C / 1000 h
Untere Grenztemperatur	Lower temperature	IEC 60512-6; Test 11 i	- 40 °C
Mechanische Kennwerte	Mechanical Characteristics		
Steck- und Ziehkraft <sup>1)</sup>	Insertion and withdrawal forces <sup>1)</sup>	IEC 60512-7; Test 13 b	20 - 30 N
Mechanische Lebensdauer	Mechanical operation	IEC 60512-5; Test 9 a	≥ 500 Steckzyklen / mating cycles
Werkstoffe	Materials		
Modul	Module		PA 6.6 GF
Farbe	Colour		schwarz / black
Kontakte	Contacts		Cu-Legierung / Cu-alloy
Kontaktoberfläche	Contact plating		Ag (silber / silver)

<sup>1)</sup> für ein Modul / for one module

<sup>2)</sup> bei Beanspruchung >10<sup>10</sup> Ω / under operating condition >10<sup>10</sup> Ω

#### Derating Kurven / Derating curves

6 mm<sup>2</sup>

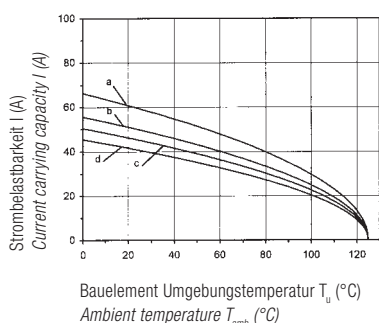

10 mm<sup>2</sup>

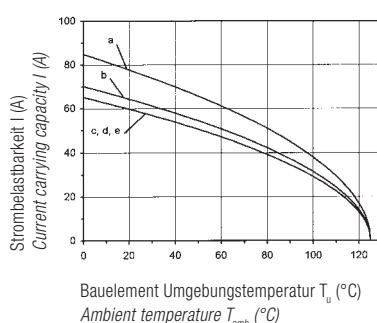

Kurve Curve	Polzahl Contacts	Rahmen Frame
a	3	2 Module
b	6	2 Module
c	9	3 Module
d	15	5 Module
e	21	7 Module

# C 146 M 3 pol

Module  
Modules

für gedrehte 3,6 mm Kontakte  
for turned 3,6 mm contacts



Abbildung Figure	Maßzeichnung / Drawing		Bestell Nr. / Part No.	
	Stiftmodul / Pin module	Buchsenmodul / Socket module	Stiftmodul / Pin module	Buchsenmodul / Socket module
			C146 A03 001 E8	C146 B03 001 E8

## Gedrehte Crimpkontakte / Turned crimp contacts

Lieferform Supplied as	für Leiterquerschnitt for wire gauge	AWG	Stückzahl Pieces	Bestell Nr. <sup>1)</sup> / Part No. <sup>1)</sup>	
				Stiftkontakt / Male contact	Buchsenkontakt / Female contact
Gedrehte Crimpkontakte / Turned crimp contacts					
versilbert / silver plating					
Einzelkontakt Single contact	1,5 mm <sup>2</sup>	16	100	VN01 036 0004 (1)C	VN02 036 0004 (1)C
	2,5 mm <sup>2</sup>	14	100	VN01 036 0005 (1)C	VN02 036 0005 (1)C
	4,0 mm <sup>2</sup>	12	100	VN01 036 0001 (1)C	VN02 036 0001 (1)C
	6,0 mm <sup>2</sup>	10	100	VN01 036 0002 (1)C <sup>2)</sup>	VN02 036 0002 (1)C <sup>2)</sup>
	10,0 mm <sup>2</sup>	8	100	VN01 036 0003 (1)C <sup>2)</sup>	VN02 036 0003 (1)C <sup>2)</sup>

## Werkzeuge / Tools <sup>3)</sup>

Bezeichnung / Description	für Leiterquerschnitt for wire gauge	Kontaktaufnahme / Contact locator	Bestell Nr. / Part No.	
			Crimpbacken / Crimping dies	Werkzeuge / Tools
Löswerkzeug für Kontakte Removal tool for contacts	–	–	–	FG 0300 146 3
Löswerkzeug für Module Removal tool for modules	–	–	–	FG 1000 146
Crimpzange für Einzelkontakte Crimping tool for single contacts	1,5 - 2,5 mm <sup>2</sup> 4,0 mm <sup>2</sup> 6,0 mm <sup>2</sup>	TA 0010 146 000 5 TA 0010 146 000 4 TA 0010 146 000 4	TA 0000 144 TA 0000 124 TA 0000 124	TA 0000
4-Kerb Crimpzange <sup>4)</sup> 4-indent crimping tool <sup>4)</sup>	1,5 - 10,0 mm <sup>2</sup>	–	–	TB 0200 146
Crimpzange für Kabelschuhe Crimping tool for cable lugs	6,0 mm <sup>2</sup> 10,0 mm <sup>2</sup>	–	TA 0000 180	TA 0000
Kabelschuhe für Schutzleiteranschluss / Cable lugs for PE connection			Stückzahl / Pieces	Bestell Nr. / Part No.
Kabelschuh cable lug	6,0 mm <sup>2</sup>	–	20	N15 006 000 9Z
	10,0 mm <sup>2</sup>	–	20	N15 010 000 7Z

<sup>1)</sup> Erläuterung der Bestell-Nr. für die Kontakte siehe Seite 4 / Explanation of the Part No. for contacts see page 4

<sup>2)</sup> Bei den Leiterquerschnitten 6 + 10 mm<sup>2</sup> sind Kabelschuhe für den Schutzleiteranschluss zu verwenden / For wire gauges 6 + 10 mm<sup>2</sup> cable lugs have to be used for PE connection

<sup>3)</sup> Weitere Informationen siehe Katalog „Werkzeuge“ / Further information see catalogue „Tools“

<sup>4)</sup> incl. Prüfstiftset, Kontaktaufnahme / incl. calibration pin set, locator

Abisolierlängen siehe S. 198 / Stripping length see p. 198



C 146 M

4 pol

4+ 

5 pol

Technische Daten  
Characteristics

Allgemeine Kennwerte	General Characteristics	Norm / Standard	Wert / Value
Polzahl	Number of contacts		4 +  / 5
Anschluss technik	Termination technique		crimpen / crimp
Anschlussquerschnitt	Wire gauge		0,5 - 4,0 mm <sup>2</sup> (AWG 20 - 12)
Brennbarkeit	Flammability	UL 94	V-0
Elektrische Kennwerte	Electrical Characteristics		
Bemessungsspannung	Rated voltage	IEC 60664-1	1000 V <sup>1)</sup>
Verschmutzungsgrad	Pollution degree	IEC 60664-1	3
Überspannungskategorie	Installation (overvoltage) category	IEC 60664-1	III
Isolierstoffgruppe	Material group	IEC 60664-1	II
Bemessungs-Stoßspannung	Rated impulse withstand voltage	IEC 60664-1	8,0 kV
Spannungsfestigkeit	Voltage proof	IEC 60512-2; Test 4 a	5,7 kV
Strombelastbarkeit	Current carrying capacity	IEC 60512-3; Test 5 b	siehe Derating Kurven / see derating curves
Durchgangswiderstand	Contact resistance	IEC 60512-2; Test 2 a	≤ 5 mΩ
Isolationswiderstand	Insulation resistance	IEC 60512-2; Test 3 a	≥ 10 <sup>12</sup> Ω
Luftstrecke	Clearance	IEC 60664-1	> 14 mm
Kriechstrecke	Creepage	IEC 60664-1	> 14 mm
Klimatische Kennwerte	Climatical Characteristics		
Prüfklasse	Climatic category	IEC 60068-1	40 / 125 / 21
Obere Grenztemperatur	Upper temperature	IEC 60512-6; Test 11 i	+ 125 °C / 1000 h
Untere Grenztemperatur	Lower temperature	IEC 60512-6; Test 11 i	- 40 °C
Mechanische Kennwerte	Mechanical Characteristics		
IP-Schutzart	IP-degree of protection	IEC 60529	20
Steck- und Ziehkraft <sup>2)</sup>	Insertion and withdrawal forces <sup>2)</sup>	IEC 60512-7; Test 13 b	15 - 20 N
Mechanische Lebensdauer	Mechanical operation	IEC 60512-5; Test 9 a	≥ 500 Steckzyklen / mating cycles
Werkstoffe	Materials		
Modul	Module		PA 6.6 GF
Farbe	Colour		schwarz / black
Kontakte Stift / Buchse	Contacts male / female		CuZn (Messing/brass) / CuSn (Bronze/bronze)
Kontaktoberfläche	Contact plating		Ag (silber / silver)

<sup>1)</sup> 630 V bei Verwendung als Steckvorrichtung / 630 V if the modules are used as plug and socket device<sup>2)</sup> für ein Modul / for one module

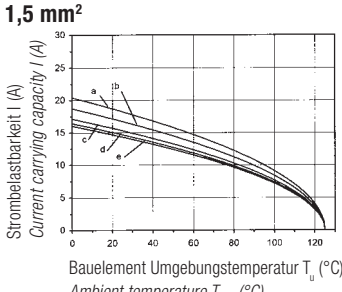
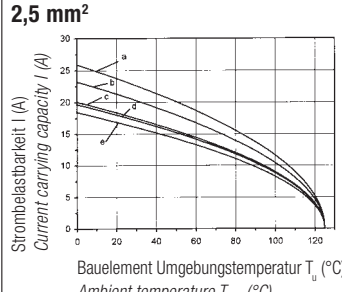
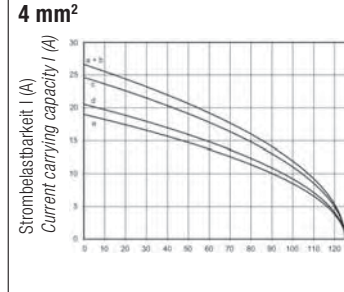
Derating Kurven / Derating curves			Kurve Curve	Polzahl Contacts	Rahmen Frame
<b>1,5 mm<sup>2</sup></b> 	<b>2,5 mm<sup>2</sup></b> 	<b>4 mm<sup>2</sup></b> 	a	5	2 Module
			b	10	2 Module
			c	15	3 Module
			d	25	5 Module
			e	35	7 Module

**C 146 M**  
**4 pol**  
**4+ **  
**5 pol**  
 Module  
 Modules

gestanzte Einzelkontakte  
 Stamped single contacts



**für gestanzte 2,5 mm Kontakte**  
**for stamped 2,5 mm contacts**

Bandkontakte für Crimpzangen  
 Contacts on reel for hand crimping tools



200 / 100 Stück  
 200 / 100 pcs

Bandkontakte für Crimpmaschinen  
 Contacts on reel for crimp machines



2000 Stück  
 (Zuführung links  
 oder rechts)

2000 pcs  
 (feeding left or  
 right hand side)

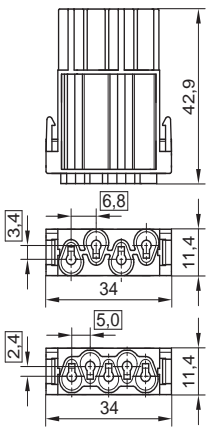
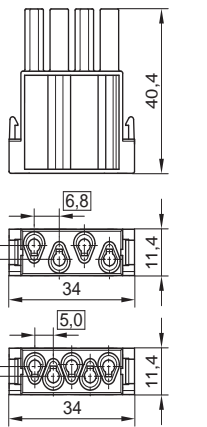
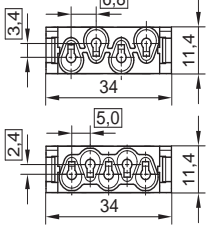
Abbildung Figure	Maßzeichnung / Drawing		Bestell Nr. / Part No.	
	Stiftmodul / Pin module	Buchsenmodul / Socket module	Stiftmodul / Pin module	Buchsenmodul / Socket module
			C146 D04 001 E8 (4 pol)  C146 D05 001 E8 (4 + PE)  C146 D05 801 E8 (5 pol)	C146 C04 001 E8 (4 pol)  C146 C05 001 E8 (4 + PE)  C146 C05 801 E8 (5 pol)
				
	PE Kontakt 2 mm voreilend PE contact 2 mm first-to-mate			

**Crimpkontakte / Crimp contacts**

Lieferform Supplied as	für Leiterquerschnitt for wire gauge	AWG	Stückzahl Pieces	Bestell Nr. <sup>1)</sup> Stiftkontakt Male contact	Part No. <sup>1)</sup> Buchsenkontakt Female contact	Bestell Nr. <sup>1)</sup> Stiftkontakt Male contact	Part No. <sup>1)</sup> Buchsenkontakt Female contact
Gestanzte Einzelkontakte / Stamped single contacts				versilbert / silver plating		vergoldet / gold plating	
	0,5 - 1,5 mm <sup>2</sup>	20 - 16	100	VN01 025 0001 (101)	VN02 025 0001 (101)	VN01 025 0001 (102)	VN02 025 0001 (102)
	1,5 - 2,5 mm <sup>2</sup>	16 - 14	100	VN01 025 0010 (101)	VN02 025 0010 (101)	VN01 025 0010 (102)	VN02 025 0010 (102)
	2,5 - 4,0 mm <sup>2</sup>	12	100	VN01 025 0043 (1)	VN02 025 0043 (1)		
Bandkontakte für Crimpzangen / Contacts on reel for hand crimping tools							
	0,5 - 1,5 mm <sup>2</sup>	20 - 16	200	ZN01 025 0001 (1)	ZN02 025 0001 (1)	ZN01 025 0001 (2)	ZN02 025 0001 (2)
	1,5 - 2,5 mm <sup>2</sup>	16 - 14	100	ZN01 025 0010 (1)	ZN02 025 0010 (1)	ZN01 025 0010 (2)	ZN02 025 0010 (2)
Bandkontakte für Crimpmaschinen / Contacts on reel for crimp machines							
Kontaktzuführung rechts Contact feeding right hand side	0,5 - 1,5 mm <sup>2</sup>	20 - 16	2000	HN01 025 0001 (1)	HN02 025 0001 (1)		
	1,5 - 2,5 mm <sup>2</sup>	16 - 14	2000	HN01 025 0010 (1)	HN02 025 0010 (1)		
Kontaktzuführung links Contact feeding left hand side	0,5 - 1,5 mm <sup>2</sup>	20 - 16	2000	TN01 025 0001 (1)	TN02 025 0001 (1)		
	1,5 - 2,5 mm <sup>2</sup>	16 - 14	2000	TN01 025 0010 (1)	TN02 025 0010 (1)		
	2,5 - 4 mm <sup>2</sup>	12	2000	TN01 025 0043 (1)	TN02 025 0043 (1)		

**Werkzeuge / Tools<sup>2)</sup>**

Bezeichnung / Description	für Leiterquerschnitt for wire gauge	Bestell Nr. / Part No.		
		Kontaktaufnahme / Contact locator	Crimpbacken / Crimping dies	Werkzeuge / Tools
Lösewerkzeug für Kontakte Removal tool for contacts	–	–	–	FG 0200 146 1
Lösewerkzeug für Module Removal tool for modules	–	–	–	FG 1000 146
Crimpzange für Einzelkontakte Crimping tool for single contacts	0,5 - 1,5 mm <sup>2</sup>	TA 0004 146 000 1	TA 0000 163	TA 0000
	1,5 - 2,5 mm <sup>2</sup>	TA 0005 146 000 3	TA 0000 141	
	2,5 - 4,0 mm <sup>2</sup>	TA 0003 146 000 1	TA 0000 121	

<sup>1)</sup> Erläuterung der Bestell-Nr. für die Kontakte siehe Seite 4 / Explanation of the Part No. for contacts see page 4

<sup>2)</sup> Weitere Informationen siehe Katalog „Werkzeuge“ / Further information see catalogue „Tools“

Abisolierlängen siehe S. 198  
 Stripping length see p. 198

C 146 M

# 3 pol Koax

**Technische Daten**  
*Characteristics*

Allgemeine Kennwerte	General Characteristics	Norm / Standard	Wert / Value
Polzahl	Number of contacts		3
Anschluss technik	Termination technique		crimpen, löten / crimp, solder
Brennbarkeit	Flammbarkeit	UL 94	V-0
Elektrische Kennwerte	Electrical Characteristics		
Bemessungsspannung	Rated voltage	IEC 60664-1	250 V
Verschmutzungsgrad	Pollution degree	IEC 60664-1	3
Überspannungskategorie	Installation (overvoltage) category	IEC 60664-1	III
Isolierstoffgruppe	Material group	IEC 60664-1	II
Wellenwiderstand	Impedance		50 Ω
Spannungsfestigkeit	Voltage proof	IEC 60512-2; Test 4 a	0,75 kV
Frequenzbereich	Working frequency		2 GHz
Durchgangswiderstand	Contact resistance	IEC 60512-2; Test 2 a	≤ 6 mΩ
Isolationswiderstand	Insulation resistance	IEC 60512-2; Test 3 a	≥ 10 <sup>6</sup> Ω
Klimatische Kennwerte	Climatical Characteristics		
Prüfklasse	Climatic category	IEC 60068-1	40 / 125 / 21
Obere Grenztemperatur	Upper temperature	IEC 60512-6; Test 11 i	+ 125 °C / 1000 h
Untere Grenztemperatur	Lower temperature	IEC 60512-6; Test 11 i	- 40 °C
Mechanische Kennwerte	Mechanical Characteristics		
Steck- und Ziehkraft <sup>1)</sup>	Insertion and withdrawal forces <sup>1)</sup>	IEC 60512-7; Test 13 b	25 - 30 N
Mechanische Lebensdauer	Mechanical operation	IEC 60512-5; Test 9 a	≥ 500 Steckzyklen / mating cycles
Werkstoffe	Materials		
Modul	Module		PA 6.6 GF
Farbe	Colour		rotbraun / redbrown
Kontakt oberfläche	Contact plating		Au (gold / gold)

<sup>1)</sup> für ein Modul / for one module

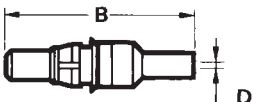
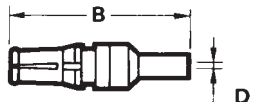
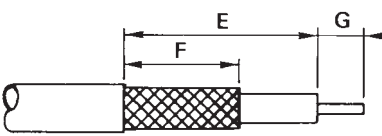
Stiftkontakt / Male contact	Buchsenkontakt / Female contact	Bestell Nr. Part No.	B	D	E	F	G
		17 DM 537 401	23,6	1,7	7,9	6,3	2
		17 DM 537 421	23,6	1,7	7,9	6,3	2
Absetzmaße / Stripping Dimensions							
		17 DM 537 405	26,3	3,2	9,5	7,9	2
		17 DM 537 425	26,3	3,2	9,5	7,9	2

C 146 M

## 3 pol Koax

Module  
Modulesfür Koax-Kontakte  
for coax-contacts

Abbildung Figure	Maßzeichnung / Drawing		Bestell Nr. / Part No.	
	Stiftmodul / Pin module	Buchsenmodul / Socket module	Stiftmodul / Pin module	Buchsenmodul / Socket module
			C146 A03 501 E8	C146 B03 501 E8

Crimpkontakte <sup>1)</sup> / Crimp contacts <sup>1)</sup>

Lieferform Supplied as	für Kabelgröße for cable size	Stückzahl Pieces	Bestell Nr. / Part No.	
			Stiftkontakt / Male contact	Buchsenkontakt / Female contact
Einzelkontakte / Single contacts				
	RG 174, 179, 316	1	17 DM 537 401	17 DM 537 421
	RG 58	1	17 DM 537 405	17 DM 537 425

Werkzeuge <sup>2)</sup> / Tools <sup>2)</sup>

Bezeichnung / Description	für Kabelgröße for cable size	6-Kant-Maß in mm 6-hex-size in mm			Bestell Nr. / Part No.	
					Crimpbacken / Crimping dies	Werkzeuge / Tools
Lösewerkzeug für Kontakte Removal tool for contacts	–	–	–	–	–	FG 0300 146 3
Lösewerkzeug für Module Removal tool for modules	–	–	–	–	–	FG 1000 146
Crimpzange für Einzelkontakte Crimping tool for single contacts	RG 58	5,4	(6,5)	(1,7)	TA 0000 401	TA 0000
	RG 174, 179, 316	3,25	(4,5)	(1,7)	TA 0000 402	TA 0000

<sup>1)</sup> Weitere Kontakte auf Anfrage / Further contacts on request<sup>2)</sup> Weitere Informationen siehe Katalog „Werkzeuge“ / Further information see catalogue „Tools“

C 146 M

3 pol

Technische Daten  
Characteristics

Allgemeine Kennwerte	General Characteristics	Norm / Standard	Wert / Value
Polzahl	Number of contacts		3
Anschluss technik	Termination technique		crimpen / crimp
Anschlussquerschnitt	Wire gauge		1,5 - 10 mm <sup>2</sup> (AWG 16 - 8)
Brennbarkeit	Flammability	UL 94	V-0
Elektrische Kennwerte	Electrical Characteristics		
Bemessungsspannung	Rated voltage	IEC 60664-1	1000 V <sup>1)</sup>
Verschmutzungsgrad	Pollution degree	IEC 60664-1	3
Überspannungskategorie	Installation (overvoltage) category	IEC 60664-1	III
Isolierstoffgruppe	Material group	IEC 60664-1	II
Bemessungs-Stoßspannung	Rated impulse withstand voltage	IEC 60664-1	8,0 kV
Spannungsfestigkeit	Voltage proof	IEC 60512-2; Test 4 a	5,7 kV
Strombelastbarkeit	Current carrying capacity	IEC 60512-3; Test 5 b	siehe Derating Kurven / see derating curves
Durchgangswiderstand	Contact resistance	IEC 60512-2; Test 2 a	≤ 1 mΩ
Isolationswiderstand	Insulation resistance	IEC 60512-2; Test 3 a	≥ 10 <sup>12</sup> Ω
Luftstrecke	Clearance	IEC 60664-1	> 14 mm
Kriechstrecke	Creepage	IEC 60664-1	> 14 mm
Klimatische Kennwerte	Climatical Characteristics		
Prüfklasse	Climatic category	IEC 60068-1	40 / 125 / 21
Obere Grenztemperatur	Upper temperature	IEC 60512-6; Test 11 i	+ 125 °C / 1000 h
Untere Grenztemperatur	Lower temperature	IEC 60512-6; Test 11 i	- 40 °C
Mechanische Kennwerte	Mechanical Characteristics		
IP-Schutzart	IP-degree of protection	IEC 60529	20
Steck- und Ziehkraft <sup>2)</sup>	Insertion and withdrawal forces <sup>2)</sup>	IEC 60512-7; Test 13 b	20 - 30 N
Mechanische Lebensdauer	Mechanical operation	IEC 60512-5; Test 9 a	≥ 500 Steckzyklen / mating cycles
Werkstoffe	Materials		
Modul	Module		PA 6.6 GF
Farbe	Colour		schwarz / black
Kontakte	Contacts		Cu-Legierung / Cu-alloy
Kontaktoberfläche	Contact plating		Ag (silber / silver)

<sup>1)</sup> 630 V bei Verwendung als Steckvorrichtung / 630 V if the modules are used as plug and socket device<sup>2)</sup> für ein Modul / for one module

## Derating Kurven / Derating curves

6 mm <sup>2</sup>		10 mm <sup>2</sup>		Kurve Curve	Polzahl Contacts	Rahmen Frame
		a	3	2 Module		
		b	6	2 Module		
		c	9	3 Module		
		d	15	5 Module		
		e	21	7 Module		



# C 146 M 3 pol

Module  
Modules



für gedrehte 3,6 mm Kontakte  
for turned 3,6 mm contacts

alle Kontakte 2 mm voreilend zu anderen Modulen  
all contacts 2 mm first-to-mate to other modules

Abbildung Figure	Maßzeichnung / Drawing		Bestell Nr. / Part No.	
	Stiftmodul / Pin module	Buchsenmodul / Socket module	Stiftmodul / Pin module	Buchsenmodul / Socket module
			C146 A03 801 E8	C146 B03 801 E8

## Crimpkontakte / Crimp contacts

Lieferform Supplied as	für Leiterquerschnitt for wire gauge	AWG	Stückzahl Pieces	Bestell Nr. <sup>1)</sup> / Part No. <sup>1)</sup>	
				Stiftkontakt / Male contact	Buchsenkontakt / Female contact
Crimpkontakte / Crimp contacts					
Einzelkontakt Single contact	1,5 mm <sup>2</sup>	16	100	VN01 036 0004 (1)C	VN02 036 0004 (1)C
	2,5 mm <sup>2</sup>	14	100	VN01 036 0005 (1)C	VN02 036 0005 (1)C
	4,0 mm <sup>2</sup>	12	100	VN01 036 0001 (1)C	VN02 036 0001 (1)C
	6,0 mm <sup>2</sup>	10	100	VN01 036 0002 (1)C <sup>2)</sup>	VN02 036 0002 (1)C <sup>2)</sup>
	10,0 mm <sup>2</sup>	8	100	VN01 036 0003 (1)C <sup>2)</sup>	VN02 036 0003 (1)C <sup>2)</sup>

## Werkzeuge / Tools <sup>3)</sup>

Bezeichnung / Description	für Leiterquerschnitt for wire gauge	Kontaktaufnahme / Contact locator	Bestell Nr. / Part No.	
			Crimpbacken / Crimping dies	Werkzeuge / Tools
Lösewerkzeug für Kontakte Removal tool for contacts	–	–	–	FG 0300 146 3
Lösewerkzeug für Module Removal tool for modules	–	–	–	FG 1000 146
Crimpzange für Einzelkontakte Crimping tool for single contacts	1,5 - 2,5 mm <sup>2</sup> 4,0 mm <sup>2</sup> 6,0 mm <sup>2</sup>	TA 0010 146 000 2 TA 0010 146 000 4 TA 0010 146 000 4	TA 0000 144 TA 0000 124 TA 0000 124	TA 0000
4-Kerb Crimpzange <sup>4)</sup> 4-indet crimping tool <sup>4)</sup>	1,5 - 10,0 mm <sup>2</sup>	–	–	TB 0200 146
Crimpzange für Kabelschuhe Crimping tool for cable lugs	6,0 mm <sup>2</sup> 10,0 mm <sup>2</sup>	–	TA 0000 180	TA 0000
Kabelschuhe für Schutzleiteranschluss / Cable lugs for PE connection			Bestell Nr. / Part No.	
Kabelschuh cable lug	6,0 mm <sup>2</sup>	–	20	N15 006 000 9Z
	10,0 mm <sup>2</sup>	–	20	N15 010 000 7Z

<sup>1)</sup> Erläuterung der Bestell-Nr. für die Kontakte siehe Seite 4 / Explanation of the Part No. for contacts see page 4

<sup>2)</sup> Bei den Leiterquerschnitten 6 + 10 mm<sup>2</sup> sind Kabelschuhe für den Schutzleiteranschluss zu verwenden / For wire gauges 6 + 10 mm<sup>2</sup> cable lugs have to be used for PE connection

<sup>3)</sup> Weitere Informationen siehe Katalog „Werkzeuge“ / Further information see catalogue „Tools“

<sup>4)</sup> incl. Prüfstiftset, Kontaktaufnahme / incl. calibration pin set, locator

**C 146 M**  
**RJ Modul**  
*RJ module*

**Technische Daten**  
*Characteristics*

<b>Allgemeine Kennwerte</b>	<b>General Characteristics</b>	<b>Norm / Standard</b>	<b>Wert / Value Module</b>	<b>Wert / Value RJ45</b>
Polzahl	<i>Number of contacts</i>		4	8
Anschluss-technik	<i>Termination technique</i>		Crimpen	Stecken
Anschlussquerschnitt	<i>Wire gauge</i>		0,14 - 2,5mm <sup>2</sup>	
Brennbarkeit	<i>Flammability</i>	UL 94	V - 0	V - 0
<b>Elektrische Kennwerte</b>	<b>Technical Characteristics</b>			
Bemessungsspannung	<i>Rated voltage</i>	IEC 60664-1	400 V AC	125 V AC
Bemessungs-Stoßspannung	<i>Rated impulse withstand voltage</i>	IEC 60664-1	6 kV	1,8 kV
Spannungsfestigkeit	<i>Voltage proof</i>	IEC 60512-2; Test 4 a	3,51 kV	1,0 kV
Strombelastbarkeit	<i>Current carrying capacity</i>	IEC 60512-3; Test 5 b	13 A <sup>1)</sup>	1,5 A
Durchgangswiderstand	<i>Contact resistance</i>	IEC 60512-2; Test 2 a	≤ 5 mΩ	≤ 20 mΩ
Isolationswiderstand	<i>Insulation resistance</i>	IEC 60512-2; Test 3 a	10 <sup>10</sup> Ω	5 <sup>8</sup> Ω
<b>Klimatische Kennwerte</b>	<b>Climatical Characteristics</b>			
Obere Grenztemperatur	<i>Upper temperature</i>	IEC 60512-6; Test 11 i	+ 100 °C / 1000 h	+ 80 °C / 1000 h
Untere Grenztemperatur	<i>Lower temperature</i>	IEC 60512-6; Test 11 i		- 20 °C
<b>Mechanische Kennwerte</b>	<b>Mechanical Characteristics</b>			
Steck- und Ziehkraft	<i>Insertion and withdrawal forces</i>	IEC 60512-7; Test 13 b	15-20 N	max. 20 N
Mechanische Lebensdauer	<i>Mechanical operation</i>	IEC 60512-5; Test 9 a	≥ 500 Steckzyklen <i>mating cycles</i>	≥ 500 Steckzyklen <i>mating cycles</i>
<b>Werkstoffe</b>	<b>Materials</b>			
Kontakteinsatz	<i>Insert</i>		PA 6.6 GF	
Farbe	<i>Colour</i>		schwarz / <i>black</i>	schwarz / <i>black</i>
Kontakte Stift / Buchse	<i>Contacts male / female</i>		CuZn	CuSn
Kontaktoberfläche	<i>Contacts plating</i>		Ag (silber / <i>silver</i> )	Au (Gold / <i>gold</i> )

1) 2 Module, 40°C Umgebungstemperatur, 1,5 mm<sup>2</sup> Anschlussquerschnitt / 2 Modules, 40°C ambient temperature, 1,5 mm<sup>2</sup> wire gauge

**RJ Modul**

Zur Integration von Standard RJ45 Komponenten • Weltweiter Echtzeit-Zugriff auf Maschinen und Anlagen

- Sehr leichte Konfektionierung durch Einsatz von Standard RJ45 Komponenten
- Ein Steckverbinder für Power, Signale und Datenübertragung
- Zusätzlich 4 Power Crimp-Kontakte
- Zeit- und Kosteneinsparungen durch einheitliche Aktiv- und Passivkomponenten
- Einheitliches Übertragungsprotokoll im Office- und Produktionsbereich
- erreicht CAT 5 für Ethernet nach ISO/IEC 11801

Rahmen für die Integration des RJ45 Moduls sowie Gehäuse für den Einbau der Rahmen entnehmen Sie bitte dem Gesamtkatalog C146 Schwere Steckverbinder

**RJ Module**



For integration of standard RJ45 components

- Worldwide real-time access on machines and facilities
- Easy assembly through the use of standard RJ45 components
- One connector for power, signal and data transmission
- 4 additional power crimp contacts
- Time- and money saving through the use of similar active- and passive components
- Unitary transmission protocol in the office- and production environment.
- Meets CAT 5 for Ethernet acc. ISO/IEC 11801

Frames for the integration of the RJ45 module as well as housings for the incorporation of the frames can be found in the full range C146 heavy connectors catalogue

**C 146 M**  
**RJ Modul**  
*RJ module*

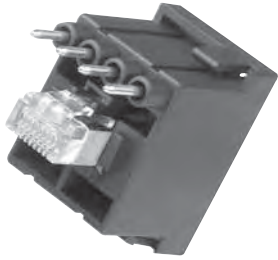
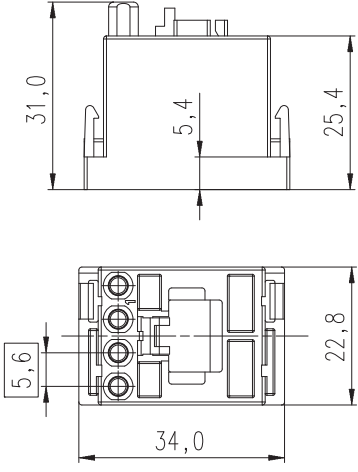
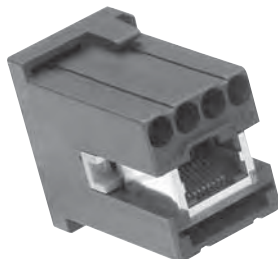
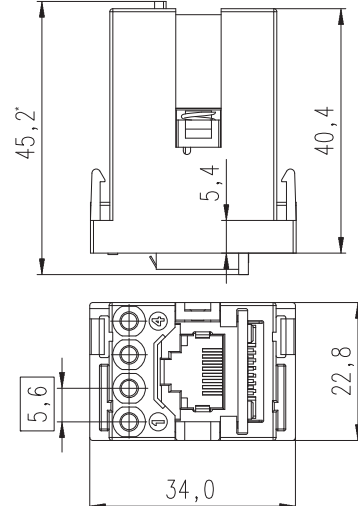
Module  
 Modules

Abbildung Figure	Maßzeichnung Drawing	Bestell Nr. Part No.
Stiftmodul / Pin module 		C146 E12 001 E8
Buchsenmodul / Socket module 		C146 F12 001 G8
Tüllengehäuse, 2x Abgang oben / Hood, 2x top entry 	10 pol 2xM25 ohne Stutzen / <i>without stud</i> 16 pol 2xM25 ohne Stutzen / <i>without stud</i> 24 pol 1xM25 + 1xM40 ohne Stutzen / <i>without stud</i>	C146 21R010 902 8 C146 21R016 910 8 C146 21R024 913 8
Kabelverschraubung, geteilt (Verpackungseinheit 5 St.) <i>Gland bushing, splitted (packing unit 5 pcs.)</i> 		VN16 250 0131 V

\*Wenn Buchse eingefedert: 46,8 / *If plug socket recessed: 46,8*

## C 146 M

### Pneu Modul

#### Pneumatic module

##### Technische Daten Characteristics

Allgemeine Kennwerte	General Characteristics	Norm / Standard	Wert / Value
Kontaktzahl	Number of contacts		1 / 2
Anschluss technik	Termination technique		Schlauchanschluss / tube termination
Anschlussquerschnitt	Wire gauge		2,5 mm / 4,0 mm
Brennbarkeit	Flammability	UL 94	V-0
Technische Kennwerte	Technical Characteristics		
Betriebsdruck	Operating pressure		8 bar mit PTFE-Schlauch (Teflon) / with PTFE tube
Schaltweg	Operating path		4,0 mm
Absperrung	Locking		einseitig absperrend / locking on one side
Pneumatikschlauch	Pneumatic tube		nur PTFE-Schläuche verwenden <sup>1)</sup> only use PTFE tubes <sup>1)</sup>
Klimatische Kennwerte	Climatical Characteristics		
Obere Grenztemperatur	Upper temperature		+100 °C
Untere Grenztemperatur	Lower temperature		- 20 °C
Mechanische Kennwerte	Mechanical Characteristics		
Mechanische Lebensdauer	Mechanical operation		5000 Steckzyklen / mating cycles
Werkstoffe	Materials		
Modul	Module		PA 6.6 GF
Farbe	Colour		schwarz / black
Kontakte	Contacts		Messing MS 58 / Brass MS 58

<sup>1)</sup> Die Module sind speziell für den Einsatz von PTFE-Schläuchen konzipiert und dürfen nur in Verbindung mit diesen eingesetzt werden. Der Einsatz von Schläuchen aus anderem Material ist nicht zu empfehlen, da die oberen und unteren Grenztemperaturen nicht erreicht werden.

<sup>1)</sup> The modules are specifically designed for the use of PTFE tubes and should only be used in conjunction with these. The use of tubes made from other materials is not recommended, as the higher and lower category temperatures will not be achievable.

### Pneu Modul

#### Leistung, Signal und Pneumatik in einem Steckverbinder

- Sehr stabile Messing-Kontakte
- Pneumatik-Buchsenkontakte mit Absperrung, schließt bei geöffnetem Steckverbinder
- Wahlweise mit 1 oder 2 Anschlüssen
- Anschluss für 2,5 mm oder 4 mm PTFE (Teflon)-Schläuchen
- Schläuche können von den Anschlüssen wieder demontiert werden

Rahmen für die Integration des Pneu Moduls sowie Gehäuse für den Einbau der Rahmen entnehmen Sie bitte dem Gesamtkatalog C146 Schwere Steckverbinder.

### Pneumatic Module



#### Power, signal and pneumatic within a single connector

- Very stable brass contacts
- Pneumatic socket contacts with barrier, closes when the connector is open
- Available with single or double connections
- Connection for 2.5 mm or 4 mm PTFE (Teflon)-tubes
- Tubes can be disassembled from the terminations

Frames for the integration of the pneumatic module as well as housings for the incorporation of the frames can be found in the full range C146 heavy connectors catalogue.

**C 146 M**  
**Pneu Modul**  
*Pneumatic module*

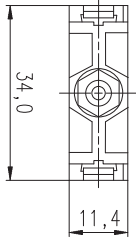
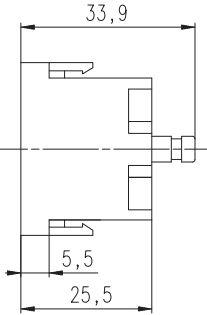
Module  
 Modules

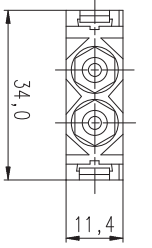
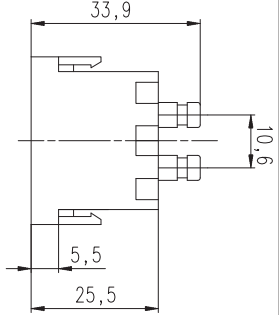









Abbildung Figure	Maßzeichnung / Drawing		Bestell Nr. / Part No.	
	Stiftmodul / Pin module	Buchsenmodul / Socket module	Stiftmodul / Pin module	Buchsenmodul / Socket module
			<b>C146 G01 014 G8</b> (2,5 mm)  <b>C146 G01 024 G8</b> (4,0 mm)	<b>C146 H01 034 G8</b> (2,5 mm)  <b>C146 H01 044 G8</b> (4,0 mm)
			<b>C146 G02 014 G8</b> (2,5 mm)  <b>C146 G02 024 G8</b> (4,0 mm)	<b>C146 H02 034 G8</b> (2,5 mm)  <b>C146 H02 044 G8</b> (4,0 mm)

M



# C 146 M



Löswerkzeuge, Zubehör  
Removal tools, accessoires

Kontaktgröße Contact size	Abbildung Figure	Bestell Nr. Part No.
1,0 mm		17D 438 SP
1,6 mm		FG 0300 146 1
2,5 mm gedreht 2,5 mm turned		FG 0300 146 4
2,5 mm gestanzt 2,5 mm stamped		FG 0200 146 1
3,6 mm		FG 0300 146 3
Modullösewerkzeug Removal tool for modules		FG 1000 146
Blind Module Blank modules		C146 A00 001 E8 (Stift/pin) C146 B00 001 E8 (Buchse/socket)
Modulkoppler Module coupler		C146 10Z000 002 8
Montagewinkel Assembly angle		C146 10Z001 001 8
Zugentlastung Strain relief		C146 10Z002 001 8

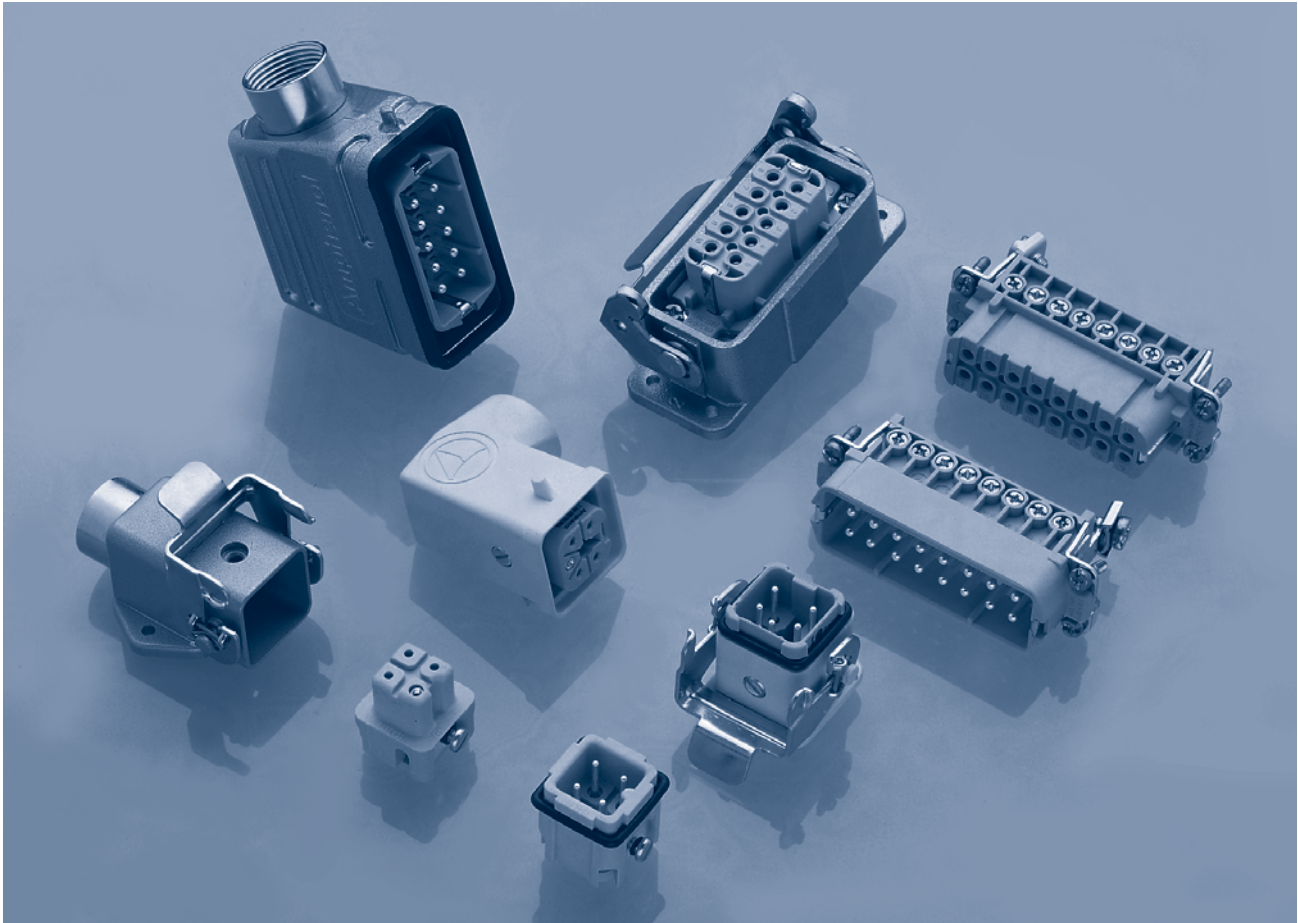
# C 146 A



A

<b>Hauptmerkmale</b>		<b>Main characteristics</b>	
<ul style="list-style-type: none"> <li>• Schmale Bauform</li> <li>• Bemessungsspannung 250 / 400 V</li> <li>• Bemessungsstrom 14 A ... 18 A</li> <li>• Anschlussart: schrauben</li> <li>• Polzahl: 3, 4, 10, 16, 32</li> </ul>		<ul style="list-style-type: none"> <li>• <i>Narrow style</i></li> <li>• <i>Rated voltage 250 / 400 V</i></li> <li>• <i>Rated current 14 A ... 18 A</i></li> <li>• <i>Termination: screw</i></li> <li>• <i>Number of contacts: 3, 4, 10, 16, 32</i></li> </ul>	
<b>Zulassungen / Approvals</b>		<b>Kennwerte / Characteristics</b>	<b>Zulassungs-Nummer / Approval-No.</b>
SEV		250 V, 10 A	
UL		600 V, 14 A	E 63093
CSA		600 V, 10 A; 16 A; 20 A	LR 700721
<p>Zulassungen beziehen sich im allgemeinen auf repräsentative Ausführungen der Steckverbinderserie. Prüfumfang und Prüfvorschrift auf Anfrage.</p>		<p><i>In general approvals refer to representative versions of the connector series. Extent and specification of tests upon request.</i></p>	

# C 146 A

## Kurzinformation Brief information

Allgemeine Hinweise



General information

- Steckverbinder der Serie C 146 A dürfen unter Spannung, jedoch nicht unter Strom betätigt werden. Werden die Steckverbinder als Steckvorrichtung eingesetzt, ist der Strom auf 10 % des Bemessungsstroms zu begrenzen.
- Für die Einsätze der Serie C 146 A (10 + 16 pol) können sowohl niedrige, wie auch hohe Gehäusebauformen verwendet werden.
- *For series C 146 A connectors may be engaged or disengaged when live but without electrical load. If these connectors are used as plug and socket device, the load shall be reduced to 10 % of the rated current.*
- *Low and high profile housing for C 146 A series inserts for 10 and 16 contacts.*

Nicht genormte Steckverbinder, aber:

*No standard for this series, but:*

- Steck- und austauschbar mit Fremdfabrikaten
  - a) Kontakteinsatz / Kontakteinsatz
  - b) Kontakteinsatz / Gehäuse 10, 16 pol.
- *Interchangeable with other makes*
  - a) *contact insert to contact insert*
  - b) *contact insert to housing 10 ,16 pin*

Gehäuse nach CECC 75 301 - 801

*Housings are designed according to CECC 75 301 - 801*

Voreilender Schutzkontakt

*First-to-mate last-to-break protective ground contact*

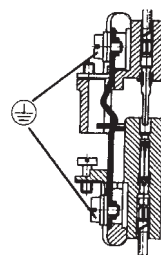

Große Gehäuseauswahl in 2 Bauhöhen (ab Seite 108)

*Large range of housings in 2 different heights (see page 108)*



Allgemeine Kennwerte	General Characteristics	Norm / Standard	Wert / Value			
Polzahl	Number of contacts		3/4 + ⊕	10 + ⊕	16 + ⊕	32 + ⊕
Anschluss technik	Termination technique		schrauben / screw			
Anschlussquerschnitt	Wire gauge		0,25 - 2,5 mm <sup>2</sup>			
Brennbarkeit	Flammability	UL 94	V-0			
Elektrische Kennwerte	Electrical Characteristics					
Bemessungsspannung	Rated voltage	IEC 60664-1	400 V	250 V		
Verschmutzungsgrad	Pollution degree	IEC 60664-1	3			
Überspannungskategorie	Installation (overvoltage) category	IEC 60664-1	III			
Isolierstoffgruppe	Material group	IEC 60664-1	III b			
Bemessungs-Stoßspannung	Rated impulse withstand voltage	IEC 60664-1	4,0 kV			
Spannungsfestigkeit	Voltage proof	IEC 60512-2; Test 4 a	2,8 kV			
Strombelastbarkeit	Current carrying capacity	IEC 60512-3; Test 5 b	siehe Derating Kurven / see derating curves			
Bemessungsstrom $T_u = 40\text{ °C}$	Rated current $T_{amp} = 40\text{ °C}$		18 A	16 A	14 A	14 A
Durchgangswiderstand	Contact resistance	IEC 60512-2; Test 2 a	≤ 5 m Ω			
Isolationswiderstand	Insulation resistance	IEC 60512-2; Test 3 a	≥ 10 <sup>12</sup> Ω <sup>1)</sup>			
Klimatische Kennwerte	Climatical Characteristics					
Prüfklasse	Climatic category	IEC 60068-1	40 / 100 / 21			
Obere Grenztemperatur	Upper temperature	IEC 60512-6; Test 11 i	+ 100 °C / 1000 h			
Untere Grenztemperatur	Lower temperature	IEC 60512-6; Test 11 i	- 40 °C			
Mechanische Kennwerte	Mechanical Characteristics					
Steck- und Ziehkraft	Insertion and withdrawal forces	IEC 60512-7; Test 13 b	15 - 20 N	50 - 70 N	80-100 N	160-200 N
<sup>2)</sup> IP-Schutzart Stifteinsatz	IP-degree of protection pin insert	IEC 60529	ungesteckt/unmated IP00		gesteckt/mated IP20	
<sup>2)</sup> IP-Schutzart Buchseneinsatz	IP-degree of protection socket insert	IEC 60529	ungesteckt/unmated IP20		gesteckt/mated IP20	
Gewicht Stifteinsatz	Weight pin insert		13 g	48 g	68 g	136 g
Gewicht Buchseneinsatz	Weight socket insert		13 g	52 g	73 g	146 g
Mechanische Lebensdauer	Mechanical operation	IEC 60512-5; Test 9 a	≥ 500 Steckzyklen / mating cycles			
Werkstoffe	Materials					
Kontakteinsatz	Insert		PA	PBT	PBT	PBT
Kontakte	Contacts		Cu Zn (Messing / brass)			
Kontakt oberfläche	Contact plating		Ag (silber / silver)			

<sup>1)</sup> Bei Beanspruchung > 10<sup>10</sup> Ω / Under operating conditions > 10<sup>10</sup> Ω







<sup>2)</sup> IP-Schutzart im Anschlussbereich der Schraubausführung IP 10 / IP-degree of protection on termination side of screw version IP 10

**C 146 A**  
**3/4 +** 

**400 V~**      **10 A**

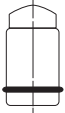
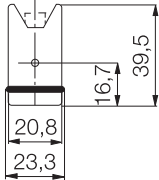
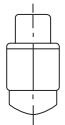
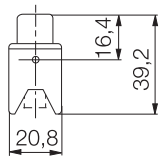
**Steckverbinder**  
**Connectors**

**Gehäuse siehe Seite 110-113**  
**Housings see page 110-113**

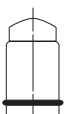
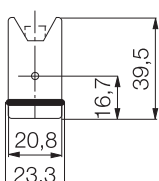
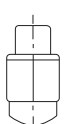
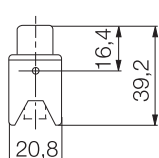
Bezeichnung - Abbildung Description - Figure	Maßzeichnung Drawing	Bestell Nr. / Part No.	
		Stifteinsatz / Male insert	Buchseneinsatz / Female insert
Kontakteinsatz Schraubanschluss <b>3 +</b>  <i>Contact insert screw termination</i> <b>3 +</b>  	Stifteinsatz <i>Male insert</i>  M  Buchseneinsatz <i>Female insert</i>  F 	C146 10A003 002 4	C146 10B003 002 4
Kontakteinsatz Schraubanschluss <b>4 +</b>  <i>Contact insert screw termination</i> <b>4 +</b>  	Stifteinsatz <i>Male insert</i>  M  Buchseneinsatz <i>Female insert</i>  F 	C146 10A004 002 4	C146 10B004 002 4

Steckbild / pin layout

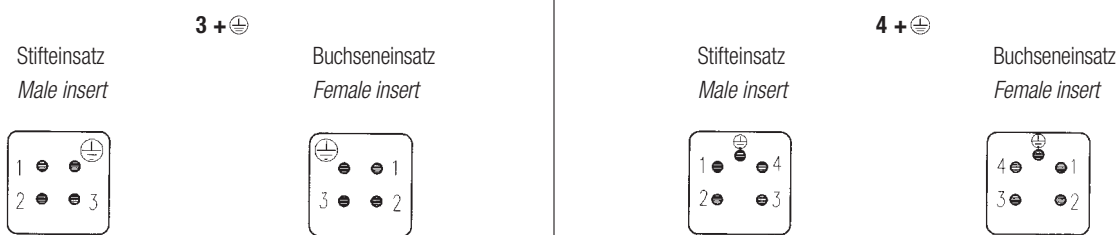

Derating Kurven / Derating curves

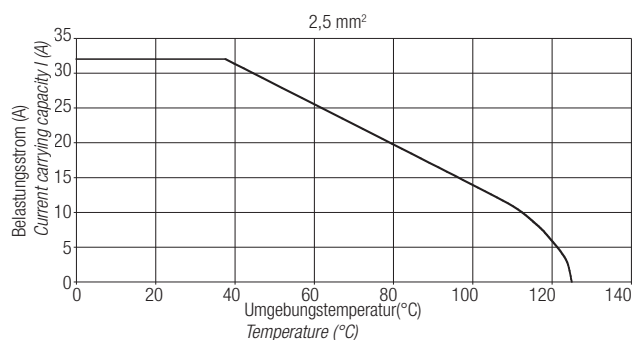
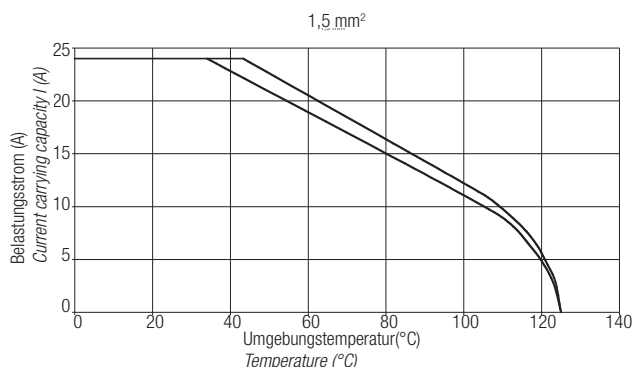



C 146 A



10 + 

250 V~

16 A

Steckverbinder  
Connectors

Gehäuse siehe Seite 114-117  
Housings see page 114-117

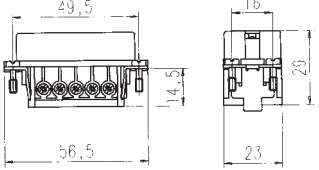
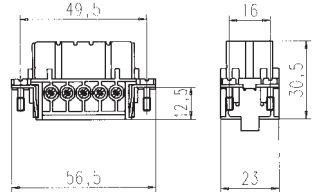
Bezeichnung - Abbildung Description - Figure	Maßzeichnung Drawing	Bestell Nr. / Part No.	
		Stifteinsatz / Male insert	Buchseinsatz / Female insert
Kontakteinsatz Schraubanschluss Contact insert screw termination    	Stifteinsatz Male insert    Buchseinsatz Female insert  	C146 10A010 002 4  C146 10A010 102 4 (mit Drahtschutz / with wire protection)	C146 10B010 002 4  C146 10B010 102 4 (mit Drahtschutz / with wire protection)

Montageanleitung, Steckbild / Assembly instruction, pin layout

Stifteinsatz  
Male insert

Buchseinsatz  
Female insert

Montageausschnitt (Kontaktträger)  
Panel cut out (insert)

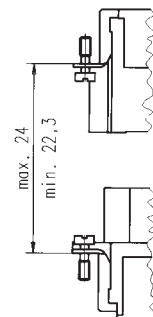
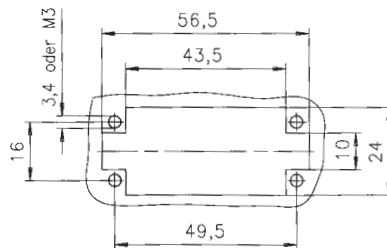
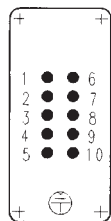
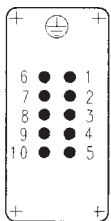

Derating Kurven / Derating curves

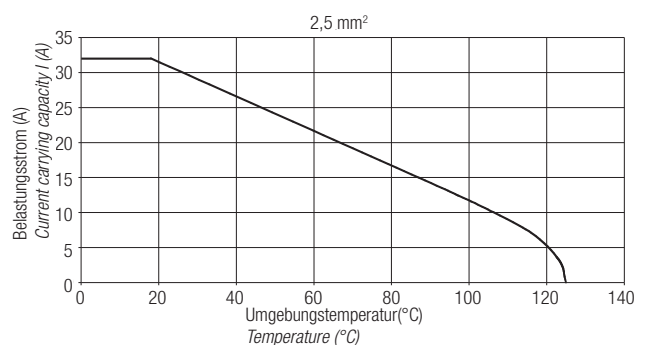
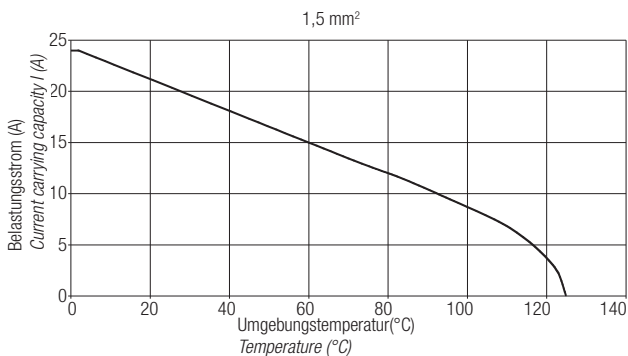

C 146 A  
**16 +** 

250 V~ 14 A

Steckverbinder  
 Connectors

Gehäuse siehe Seite 118-121  
 Housings see page 118-121

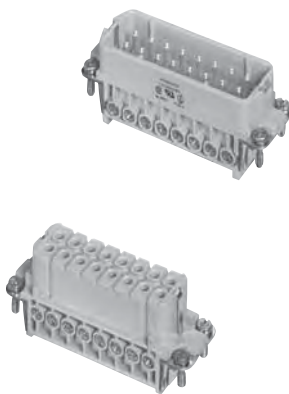
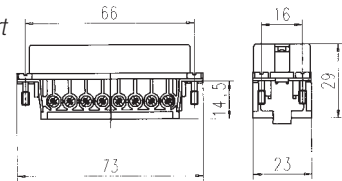
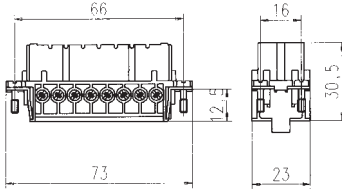
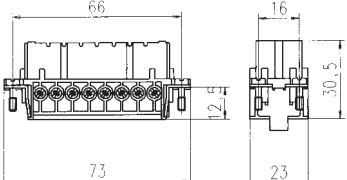
Bezeichnung - Abbildung Description - Figure	Maßzeichnung Drawing	Bestell Nr. / Part No.	
		Stifteinsatz / Male insert	Buchseinsatz / Female insert
Kontaktsatz Schraubanschluss Contact insert screw termination  	Stifteinsatz Male insert  Buchseinsatz Female insert 	C146 10A016 002 4  C146 10A016 102 4 (mit Drahtschutz / with wire protection)	C146 10B016 002 4  C146 10B016 102 4 (mit Drahtschutz / with wire protection)

Montageanleitung, Steckbild / Assembly instruction, pin layout

Stifteinsatz  
 Male insert

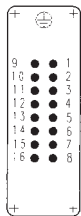

Buchseinsatz  
 Female insert

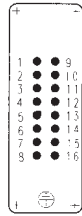

Montageausschnitt (Kontaktträger)  
 Panel cut out (insert)

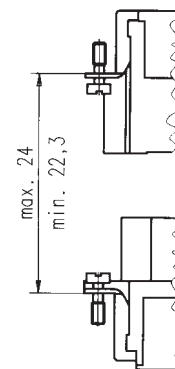
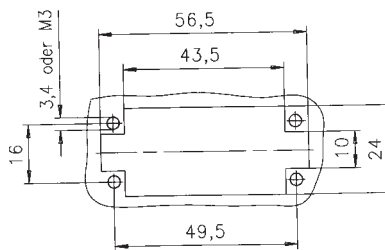

Derating Kurven / Derating curves

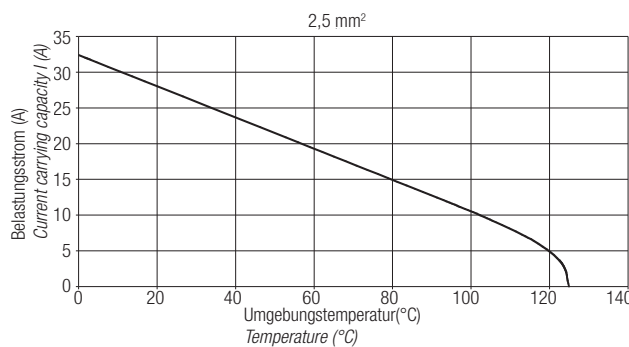
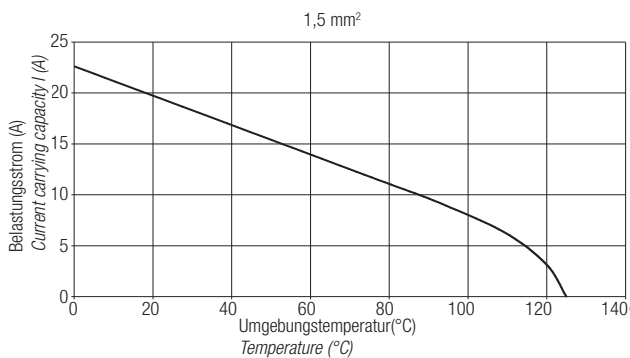

C 146 A  
**32 +** 

250 V~ 14 A

Steckverbinder  
 Connectors

Gehäuse siehe Seite 122-125  
 Housings see page 122-125

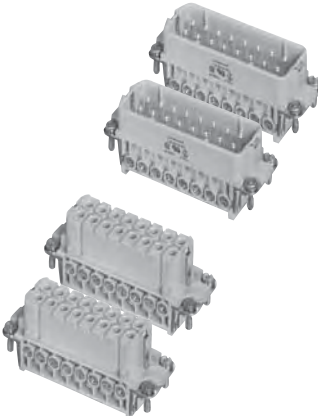
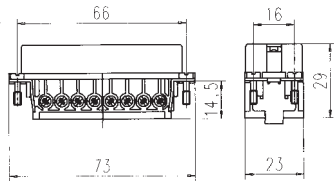
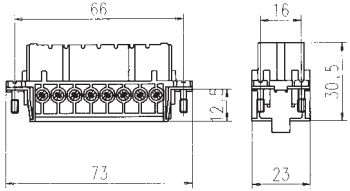
Bezeichnung - Abbildung Description - Figure	Maßzeichnung Drawing	Bestell Nr. / Part No.	
		Stifteinsatz / Male insert	Buchseinsatz / Female insert
Kontakteinsatz Schraubanschluss Contact insert screw termination 	Stifteinsatz Male insert   Buchseinsatz Female insert 	C146 10A016 002 4 (1 - 16)  +  C146 10A016 004 4 (17 - 32)	C146 10B016 002 4 (1 - 16)  +  C146 10B016 004 4 (17 - 32)
		C146 10A016 102 4 (1 - 16)  +  C146 10A016 104 4 (17 - 32) (mit Drahtschutz / with wire protection)	C146 10B016 102 4 (1 - 16)  +  C146 10B016 104 4 (17 - 32) (mit Drahtschutz / with wire protection)

Montageanleitung, Steckbild / Assembly instruction, pin layout

Stifteinsatz  
Male insert

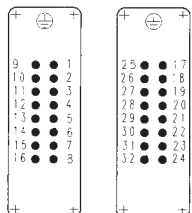

Buchseinsatz  
Female insert

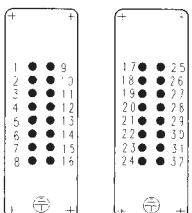

Montageausschnitt (Kontaktträger)  
Panel cut out (insert)

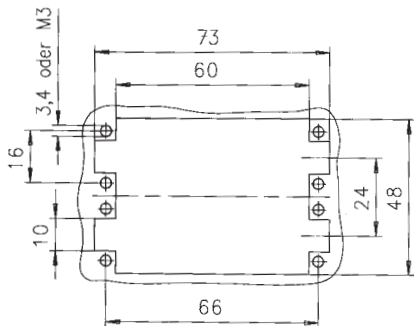

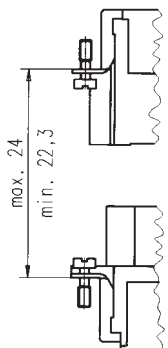



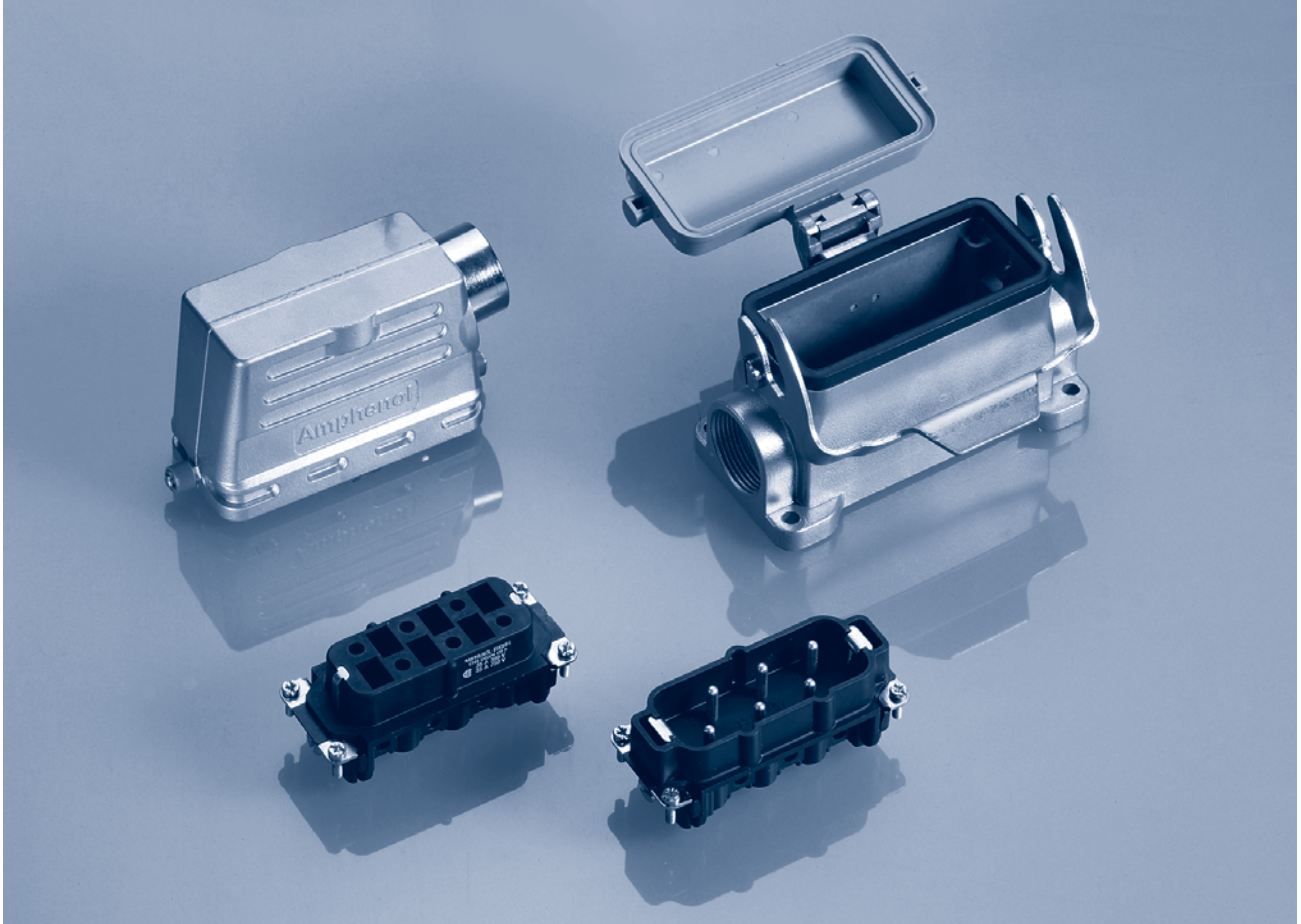

# C 146 HSE



HSE

<b>Hauptmerkmale</b>		<b>Main characteristics</b>	
<ul style="list-style-type: none"> <li>• Bemessungsspannung 400 V</li> <li>• Bemessungsstrom 42 A</li> <li>• Anschlussart: schrauben</li> <li>• Anschlussquerschnitt: 6mm<sup>2</sup></li> <li>• Polzahl: 6</li> </ul>		<ul style="list-style-type: none"> <li>• Rated voltage 400 V</li> <li>• Rated current 42 A</li> <li>• Termination: screw</li> <li>• Max. wire gauge 6 mm<sup>2</sup></li> <li>• Number of contacts: 6</li> </ul>	
<b>Zulassungen / Approvals</b>		<b>Kennwerte / Characteristics</b>	<b>Zulassungs-Nummer / Approval-No.</b>
Prüf- stelle / Testhouse			
UL		600 V, 35 A	48932
CSA		600 V, 35 A	E 63093
Zulassungen beziehen sich im allgemeinen auf repräsentative Ausführungen der Steckverbinderserie. Prüfumfang und Prüfvorschrift auf Anfrage.		In general approvals refer to representative versions of the connector series. Extent and specification of tests upon request.	



Allgemeine Kennwerte	General Characteristics	Norm / Standard	Wert / Value	
Polzahl	Number of contacts		6 + ⊕	
Anschluss technik	Termination technique		schrauben / screw	
Anschlussquerschnitt	Wire gauge		0,5 - 6,0 mm <sup>2</sup> (Ø 3,4 mm)	
Brennbarkeit	Flammability	UL 94	V-0	
Elektrische Kennwerte	Electrical Characteristics			
Bemessungsspannung	Rated voltage	IEC 60664-1	400 V (600 V UL / CSA <sup>2</sup> )	
Verschmutzungsgrad	Pollution degree	IEC 60664-1	3	
Überspannungskategorie	Installation (overvoltage) category	IEC 60664-1	III	
Isolierstoffgruppe	Material group	IEC 60664-1	II	
Bemessungs-Stoßspannung	Rated impulse withstand voltage	IEC 60664-1	6,0 kV	
Spannungsfestigkeit	Voltage proof	IEC 60512-2; Test 4 a	2200 V	
Strombelastbarkeit	Rated current	IEC 60512-3; Test 5 b	siehe Derating Kurven / see derating curves	
Bemessungsstrom $T_u = 40\text{ °C}$	Rated current $T_{amp} = 40\text{ °C}$		42 A	
Durchgangswiderstand	Contact resistance	IEC 60512-2; Test 2 a	≤ 1 m Ω	
Isolationswiderstand	Insulation resistance	IEC 60512-2; Test 3 a	≥ 10 <sup>12</sup> Ω <sup>1)</sup>	
Luftstrecke	Clearance	IEC 60664-1	≥ 3,5 mm	
Kriechstrecke	Creepage	IEC 60664-1	≥ 5,6 mm	
Klimatische Kennwerte	Climatical Characteristics			
Prüfklasse	Climatic category	IEC 60068-1	40 / 125 / 21	
Obere Grenztemperatur	Upper temperature	IEC 60512-6; Test 11 i	+ 125 °C / 1000 h	
Untere Grenztemperatur	Lower temperature	IEC 60512-6; Test 11 i	- 40 °C	
Mechanische Kennwerte	Mechanical Characteristics			
Steck- und Ziehkraft	Insertion and withdrawal forces	IEC 60512-7; Test 13 b	40 - 60 N	
<sup>3)</sup> IP-Schutzart Stifteinsatz	IP-degree of protection pin insert	IEC 60529	ungesteckt/unmated IP00	gesteckt/mated IP20
<sup>3)</sup> IP-Schutzart Buchseneinsatz	IP-degree of protection socket insert	IEC 60529	ungesteckt/unmated IP20	gesteckt/mated IP20
Gewicht Stifteinsatz	Weight pin insert		80 g	
Gewicht Buchseneinsatz	Weight socket insert		80 g	
Mechanische Lebensdauer	Mechanical operation	IEC 60512-5; Test 9 a	≥ 500 Steckzyklen / mating cycles	
Werkstoffe	Materials			
Kontakteinsatz	Insert		PA, GV	
Kontakte	Contacts		Cu Zn (Messing / brass)	
Kontaktoberfläche	Contact plating		Ag (silber / silver)	
Farbe	Colour		schwarz / black	

<sup>1)</sup> Bei Beanspruchung > 10<sup>10</sup> Ω / Under operating conditions > 10<sup>10</sup> Ω

<sup>2)</sup> Hinweisschild für CSA-Anwendung siehe Seite 176/ Label for CSA application see page 176

<sup>3)</sup> IP-Schutzart im Anschlussbereich IP 10 / IP-degree of protection on termination side IP 10

C 146 HSE

6 + 

400 V~

42 A

Steckverbinder  
Connectors

Gehäuse siehe Seite 138-145  
Housings see page 138-145

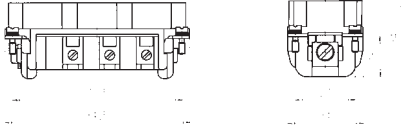
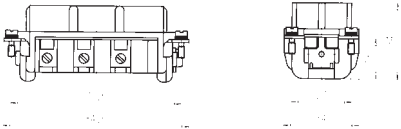
Bezeichnung - Abbildung Description - Figure	Maßzeichnung Drawing	Bestell Nr. / Part No.	
		Stifteinsatz / Male insert	Buchseinsatz / Female insert
Kontakteinsatz Schraubanschluss Contact insert screw termination	<p>Stifteinsatz Male insert</p>  <p>Buchseinsatz Female insert</p> 	C146 10A006 102 5 (mit Drahtschutz / with wire protection)	C146 10B006 102 5 (mit Drahtschutz / with wire protection)

Montageanleitung Steckbild / Assembly instruction pin layout

Stifteinsatz  
Male insert

Buchseinsatz  
Female insert

Montageausschnitt (Kontaktträger)  
Panel cut out (insert)

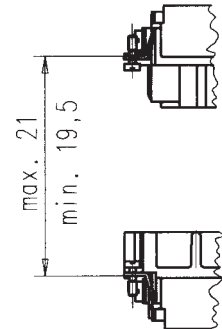
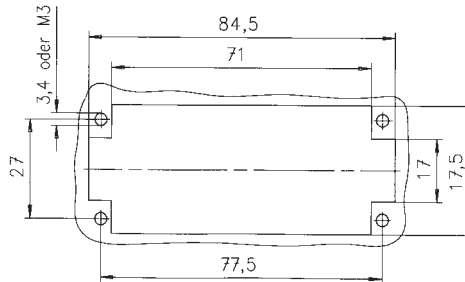
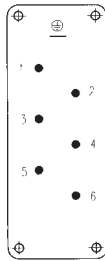
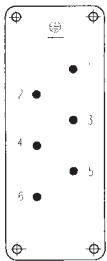

Derating Kurven / Derating curves

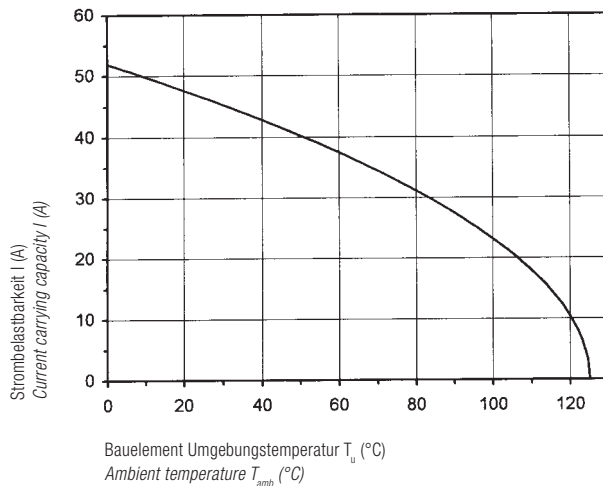



Anschlussquerschnitt 6 mm<sup>2</sup>  
Wire gauge 6 mm<sup>2</sup>

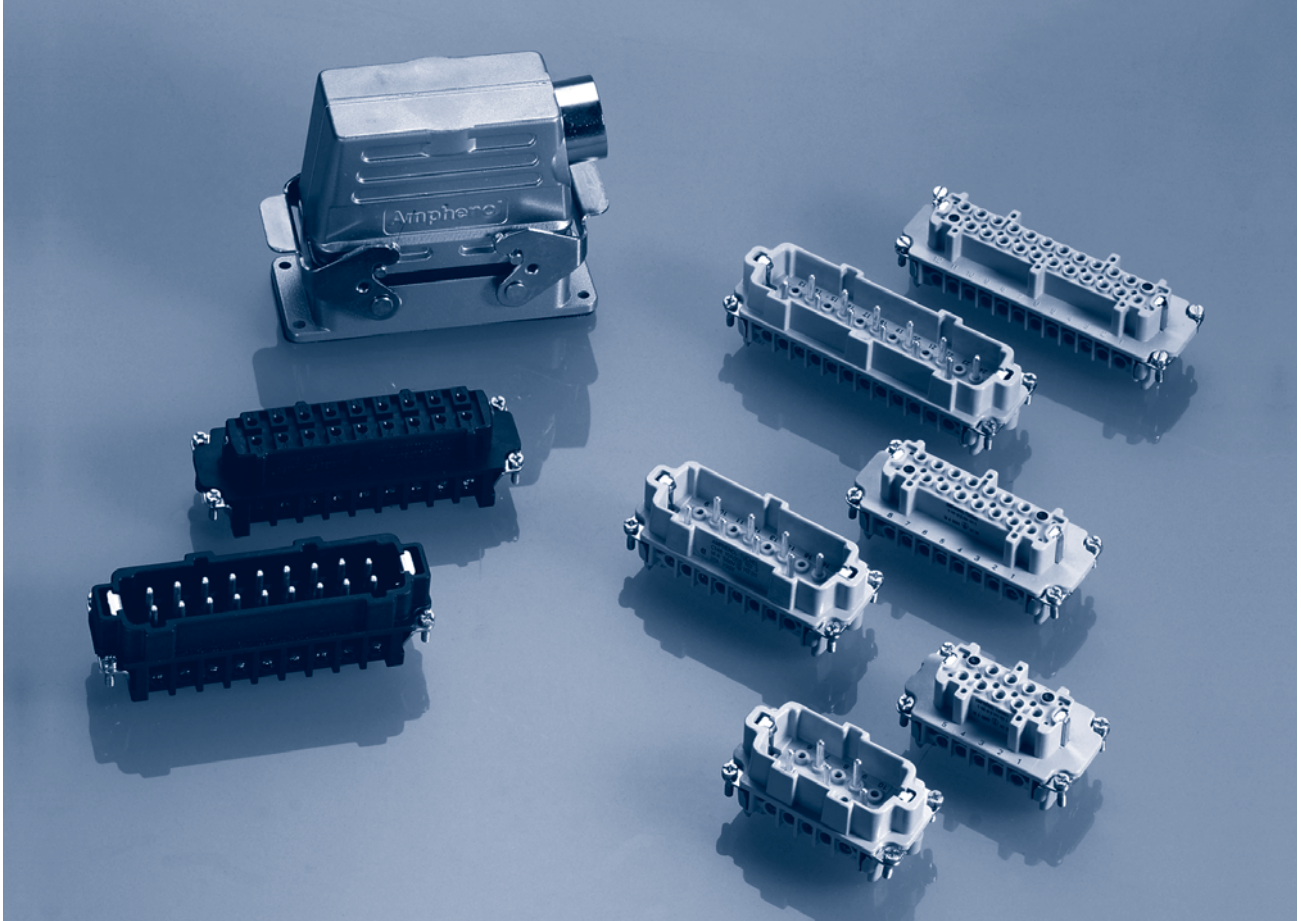

# C 146 HvE



HvE

<b>Hauptmerkmale</b>		<b>Main characteristics</b>	
<ul style="list-style-type: none"> <li>• Bemessungsspannung 660 V</li> <li>• Bemessungsstrom 16 A ... 22 A</li> <li>• Anschlussart: schrauben</li> <li>• 2 nacheilende Schaltkontakte</li> <li>• Polzahl: 3, 6, 10, 16, 20, 26, 32</li> </ul>		<ul style="list-style-type: none"> <li>• Rated voltage 660 V</li> <li>• Rated current 16 A ... 22 A</li> <li>• Termination: screw</li> <li>• 2 delayed mating contacts</li> <li>• Number of contacts: 3, 6, 10, 16, 20, 26, 32</li> </ul>	
<b>Zulassungen / Approvals</b>	<b>Prüfstelle / Testhouse</b>	<b>Kennwerte / Characteristics</b>	<b>Zulassungs-Nummer / Approval-No.</b>
SEV		660 V, 16 / 22 A	
UL		600 V, 10 A	E 63093
CSA		600 V, 20 A	48932
<p>Zulassungen beziehen sich im allgemeinen auf repräsentative Ausführungen der Steckverbinderserie. Prüfumfang und Prüfvorschrift auf Anfrage.</p>		<p><i>In general approvals refer to representative versions of the connector series. Extent and specification of tests upon request.</i></p>	

# C 146 HvE

## Kurzinformation Brief information

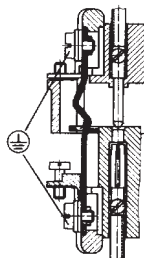
<p>Konstruktiver Aufbau der HvE-Steckverbindung</p> <p><i>Construction of connectors Type HvE</i></p>	<p>Die Steckverbindung der Serie C 146 HvE sind wie folgt aus der Baureihe C 146 E abgeleitet:</p> <p><i>The connectors of series C 146 HvE are based on series C 146 E with the following deviations:</i></p>
<p>Kontakteinsätze</p> <p><i>Inserts</i></p>	<p>Die 3, 6 und 10-pol. HVE-Kontakteinsätze gehen aus den 10, 16 und 24-pol. Isolierkörpern der Baureihe C 146 E durch Teilbestückung und 2 zusätzlichen, nacheilenden Schaltkontakten hervor. Lediglich die Polzahl 16 HVE besitzt in der Steckgeometrie abweichende Kontaktträger. Ihre äußeren Abmessungen sind jedoch mit denen der Polzahl 24, Serie C 146 E identisch. Die nacheilenden Schaltkontakte ermöglichen den Anschluss einer Schützwicklung zum Zweck der elektrischen Verriegelung. Das bedeutet spannungslose Buchseneinsätze im ungesteckten Zustand.</p> <p>Werden Steckverbinder ohne Schaltleistung als Steckverbinder mit Schaltleistung eingesetzt, so müssen die elektrischen Leistungsdaten gemäß den Angaben des Herstellers reduziert werden. Diese Angaben sind beim Hersteller zu erfragen.</p> <p>C 146 E-Stifteinsätze (400 V) und C 146 HvE-Buchseneinsätze sind nicht miteinander steckbar, da a) bei den 3, 6 und 10-pol. Buchseneinsätzen 2 nicht belegte Kontaktkammern verschlossen sind. (Blindstopfen). b) die 16-pol. HVE-Kontaktträger eine abweichende Steckgeometrie besitzen.</p> <p><i>The HVE-inserts with 3, 6 and 10 contacts are basically the same as the 10, 16 and 24-contacts inserts of series C 146 E. However they are only partly loaded with contacts and have two delayed mating pilot duty contacts. Only type 16 HVE has special inserts with a different contact arrangement. The mounting dimensions are however identical with the 24 contacts version of C 146 E. The delayed mating contacts are intended for switching a relay coil for electrically locking in order to have unloaded socket contacts in an unmated condition.</i></p> <p><i>If connectors without breaking capacity are used as connectors with breaking capacity the electrical power data must be reduced in accordance with the manufacturer's specification. These specifications are available from the manufacturer.</i></p> <p><i>C 146 E inserts with pin contacts are not intermatable with C 146 HvE inserts with socket contacts due to</i> a) <i>two empty contact holes are closed at 3, 6 and 10 contact inserts.</i> b) <i>the 16 contacts HVE insert has a different contact arrangement.</i></p>
<p>Gehäuse: (aus Alu-Druckguss)</p> <p><i>Housings: (made of aluminium)</i></p>	<p>Verwendet werden beim 16-pol. HvE-Kontakteinsatz C 146 E-Gehäuse mit Isolationsauskleidung. (Isolationsfolie an Innenwand). Die Sperrstege an den Gehäuseinnenwänden (Schmalseite), die das Einsetzen der 660 V-Kontaktträger in 400 V-Gehäusen verhindern, sind entfernt. Der 16-pol. HvE-Einsatz mit stirnseitigem Sperrstück ist jetzt montierbar.</p> <p><i>C 146 E housings with an inside insulation (plastic foil) are used for the 16-contacts insert. The inside barriers at the narrow sides preventing mounting of 660 V-inserts in 400 V housings are removed and the 16-contacts insert is now mountable.</i></p>
<p>Nicht genormte Steckverbinder, aber:</p> <p><i>No standard for this series, but:</i></p>	<p>Steck- und austauschbar mit Fremdfabrikaten</p> <p>a) Kontakteinsatz/Kontakteinsatz b) Kontakteinsatz/Gehäuse 6, 10, 16, 24 pol.</p> <p><i>Intermateable and exchangeable with other makes</i></p> <p>a) <i>Contact insert to contact insert</i> b) <i>Contact insert to housing 6, 10, 16, 24 pin</i></p> <p>Gehäuse nach DIN 43620 (CECC 75 301-801, EN 175 301-801)</p> <p><i>Housings are designed according to DIN 43620 (CECC 75 301-801, EN 175 301-801)</i></p>
<p>Voreilender Schutzkontakt</p> <p><i>First-to-mate last-to-break protective ground contact</i></p>	



<b>Allgemeine Kennwerte</b>	<b>General Characteristics</b>	<b>Norm / Standard</b>	<b>Wert / Value</b>							
Polzahl	<i>Number of contacts</i>		3	6	10	16	20	26 <sup>4)</sup>	32	
Anschluss technik	<i>Termination technique</i>		schrauben / <i>screw</i>							
Anschlussquerschnitt	<i>Wire gauge</i>		0,25 - 2,5 mm <sup>2</sup>							
Brennbarkeit	<i>Flammability</i>	UL 94	V-0							
<b>Elektrische Kennwerte</b>	<b>Electrical Characteristics</b>									
Bemessungsspannung	<i>Rated voltage</i>	IEC 60664-1	660 V <sup>1)</sup> (600 V UL / CSA <sup>3)</sup> )							
Verschmutzungsgrad	<i>Pollution degree</i>	IEC 60664-1	3							
Überspannungskategorie	<i>Installation (overvoltage) category</i>	IEC 60664-1	III							
Isolierstoffgruppe	<i>Material group</i>	IEC 60664-1	III a		II	IIIa	<sup>4)</sup>	II		
Bemessungs-Stoßspannung	<i>Rated impulse withstand voltage</i>	IEC 60664-1	8,0 kV							
Spannungsfestigkeit	<i>Voltage proof</i>	IEC 60512-2; Test 4 a	3,5 kV							
Strombelastbarkeit	<i>Current carrying capacity</i>	IEC 60512-3; Test 5 b	siehe Derating Kurven / <i>see derating curves</i>							
Durchgangswiderstand	<i>Contact resistance</i>	IEC 60512-2; Test 2 a	≤ 5 m Ω							
Isolationswiderstand	<i>Insulation resistance</i>	IEC 60512-2; Test 3 a	≥ 10 <sup>12</sup> Ω <sup>2)</sup>							
<b>Klimatische Kennwerte</b>	<b>Climatical Characteristics</b>									
Prüfklasse	<i>Climatic category</i>	IEC 60068-1	40 / 125 / 21							
Obere Grenztemperatur	<i>Upper temperature</i>	IEC 60512-6; Test 11 i	+ 125 °C / 1000 h							
Untere Grenztemperatur	<i>Lower temperature</i>	IEC 60512-6; Test 11 i	- 40 °C							
<b>Mechanische Kennwerte</b>	<b>Mechanical Characteristics</b>									
<sup>5)</sup> IP-Schutzart Stifteinsatz	<i>IP-degree of protection pin insert</i>	IEC 60529	ungesteckt/ <i>unmated</i> IP00				gesteckt/ <i>mated</i> IP20			
<sup>5)</sup> IP-Schutzart Buchseneinsatz	<i>IP-degree of protection socket insert</i>	IEC 60529	ungesteckt/ <i>unmated</i> IP20				gesteckt/ <i>mated</i> IP20			
Gewicht Stifteinsatz	<i>Weight pin insert</i>		49 g	63 g	81 g	107 g	162 g	189 g	214 g	
Gewicht Buchseneinsatz	<i>Weight socket insert</i>		49 g	63 g	81 g	107 g	162 g	189 g	214 g	
Mechanische Lebensdauer	<i>Mechanical operation</i>	IEC 60512-5; Test 9 a	≥ 500 Steckzyklen / <i>mating cycles</i>							
<b>Werkstoffe</b>	<b>Materials</b>									
Kontakteinsatz	<i>Insert</i>		PC, GV		PA, GV	PC, GV	<sup>4)</sup>	PA, GV		
Kontakte	<i>Contacts</i>		Cu Zn (Messing / <i>brass</i> )							
Kontakt oberfläche	<i>Contact plating</i>		Ag (silber / <i>silver</i> )							
Farbe	<i>Colour</i>		grau / <i>grey</i>		schwarz <i>black</i>	grau <i>grey</i>	<sup>4)</sup>	schwarz <i>black</i>		

<sup>1)</sup> für Arbeitskontakte, 400 V für Schaltkontakte / *for working contacts, 400 V for mating contacts*

<sup>2)</sup> bei Beanspruchung > 10<sup>10</sup> Ω / *Under operating conditions > 10<sup>10</sup> Ω*

<sup>3)</sup> Hinweisschild für CSA-Anwendung siehe Seite 186 / *Label for CSA application see page 186*

<sup>4)</sup> Kombination 10- und 16-polig; d.h. Werkstoff PC und PA / *Combination 10 and 16 ways, i.e. material PC and PA*

<sup>5)</sup> IP-Schutzart im Anschlussbereich IP 10 / *IP-degree of protection on termination side IP 10*

C 146 HvE

3 +  + 2

660 V~

16 / 22 A

2 nacheilende Schaltkontakte  
2 delayed mating contacts

Steckverbinder  
Connectors

Gehäuse siehe Seite 130-137  
Housings see page 130-137

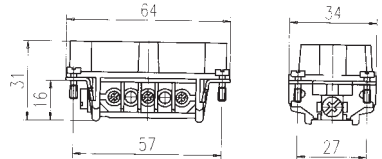
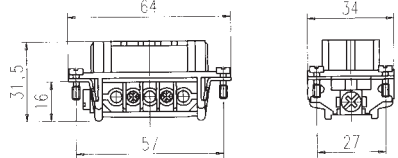
Bezeichnung - Abbildung Description - Figure	Maßzeichnung Drawing	Bestell Nr. / Part No.	
		Stifteinsatz / Male insert	Buchseneinsatz / Female insert
Kontakteinsatz Schraubanschluss <sup>1)</sup> Contact insert screw termination <sup>1)</sup>	<p>Stifteinsatz Male insert</p>  <p>Buchseneinsatz Female insert</p> 	C146 10A003 102 3	C146 10B003 102 3

Montageanleitung, Steckbild / Assembly instruction, pin layout

Stifteinsatz  
Male insert

Buchseneinsatz  
Female insert

Montageausschnitt (Kontaktträger)  
Panel cut out (insert)

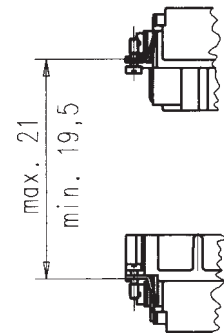
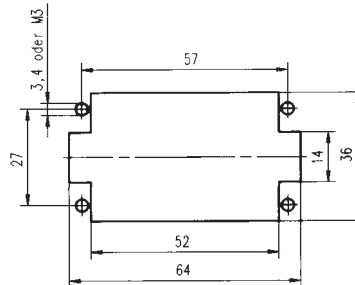
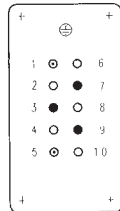
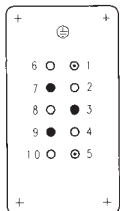

- Arbeitskontakt / working contact
- ⊙ Schaltkontakt / mating contact
- Leerstelle / without contact

Derating Kurve / Derating curve

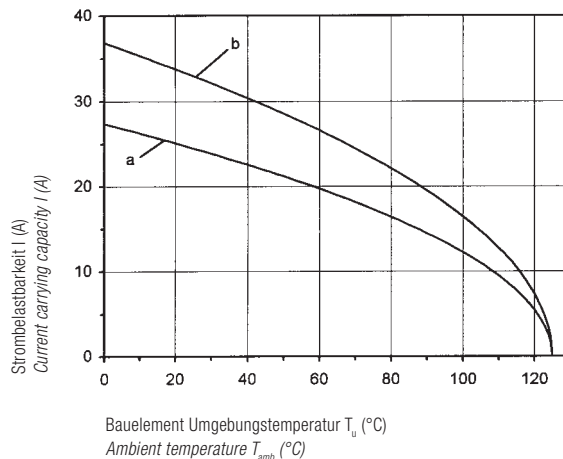

Begrenzung durch Leiter beachten  
Notice restriction of wire

Kurve a Anschlussquerschnitt 1,5 mm<sup>2</sup>  
Curve a wire gauge 1,5 mm<sup>2</sup>

Kurve b Anschlussquerschnitt 2,5 mm<sup>2</sup>  
Curve b wire gauge 2,5 mm<sup>2</sup>

1) mit Drahtschutz / with wire protection

C 146 HvE

6 +  + 2

Steckverbinder  
Connectors

660 V~

16 / 22 A

2 nacheilende Schaltkontakte  
2 delayed mating contacts

Gehäuse siehe Seite 138-145  
Housings see page 138-145

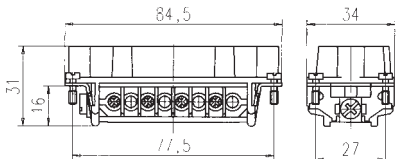
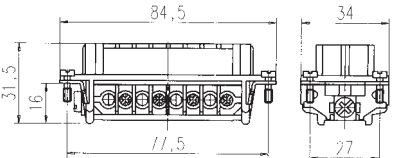
Bezeichnung - Abbildung Description - Figure	Maßzeichnung Drawing	Bestell Nr. / Part No.	
		Stifteinsatz / Male insert	Buchseneinsatz / Female insert
Kontakteinsatz Schraubanschluss <sup>1)</sup> Contact insert screw termination <sup>1)</sup>	<p>Stifteinsatz Male insert</p>  <p>Buchseneinsatz Female insert</p> 	C146 10A006 102 3	C146 10B006 102 3

Montageanleitung, Steckbild / Assembly instruction, pin layout

Stifteinsatz  
Male insert

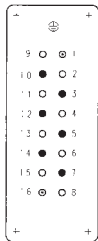

Buchseneinsatz  
Female insert

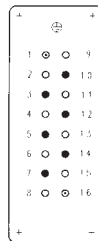

Montageausschnitt (Kontaktträger)  
Panel cut out (insert)

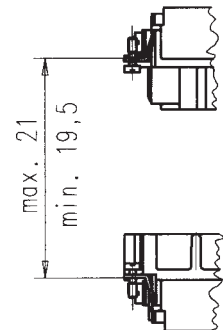
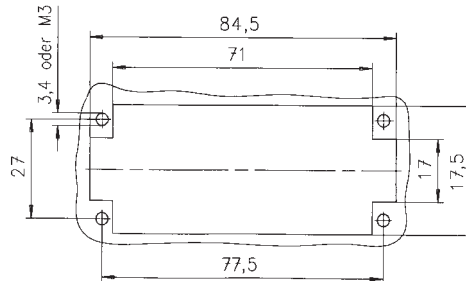

- Arbeitskontakt / working contact
- ⊙ Schaltkontakt / mating contact
- Leerstelle / without contact

Derating Kurve / Derating curve

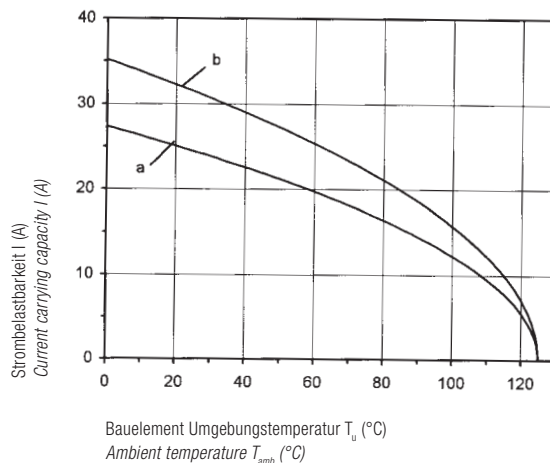

Begrenzung durch Leiter beachten  
Notice restriction of wire

Kurve a Anschlussquerschnitt 1,5 mm<sup>2</sup>  
Curve a wire gauge 1,5 mm<sup>2</sup>

Kurve b Anschlussquerschnitt 2,5 mm<sup>2</sup>  
Curve b wire gauge 2,5 mm<sup>2</sup>

1) mit Drahtschutz / with wire protection

C 146 HVE

10 +  + 2

660 V~

16 / 22 A

2 nacheilende Schaltkontakte  
2 delayed mating contacts

Steckverbinder  
Connectors

Gehäuse siehe Seite 146-153  
Housings see page 146-153

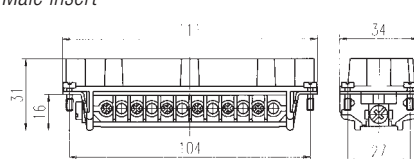
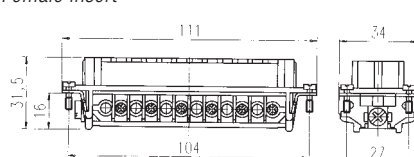
Bezeichnung - Abbildung Description - Figure	Maßzeichnung Drawing	Bestell Nr. / Part No.	
		Stifteinsatz / Male insert	Buchseneinsatz / Female insert
Kontakteinsatz Schraubanschluss <sup>1)</sup> Contact insert screw termination <sup>1)</sup>	<p>Stifteinsatz Male insert</p>  <p>Buchseneinsatz Female insert</p> 	C146 10A010 102 3	C146 10B010 102 3

Montageanleitung, Steckbild / Assembly instruction, pin layout

Stifteinsatz  
Male insert

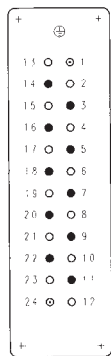

Buchseneinsatz  
Female insert

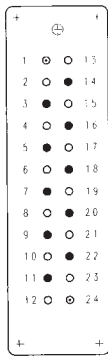

Montageausschnitt (Kontaktträger)  
Panel cut out (insert)

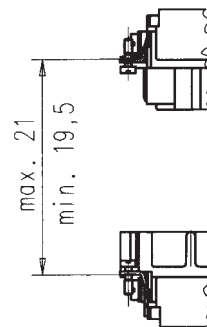
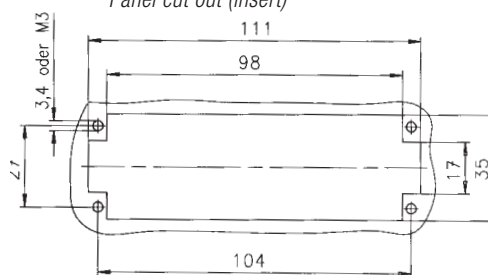

- Arbeitskontakt / working contact
- Schaltkontakt / mating contact
- Leerstelle / without contact

Derating Kurve / Derating curve

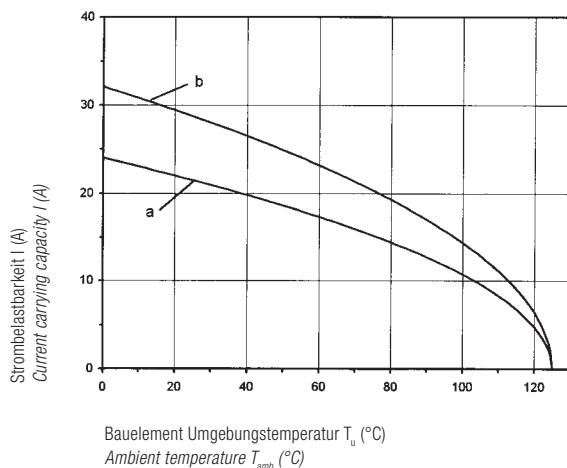

Begrenzung durch Leiter beachten  
Notice restriction of wire

Kurve a Anschlussquerschnitt 1,5 mm<sup>2</sup>  
Curve a wire gauge 1,5 mm<sup>2</sup>

Kurve b Anschlussquerschnitt 2,5 mm<sup>2</sup>  
Curve b wire gauge 2,5 mm<sup>2</sup>

1) mit Drahtschutz / with wire protection

C 146 HvE

16 +  + 2

660 V~

16 / 22 A

2 nacheilende Schaltkontakte  
2 delayed mating contacts

Steckverbinder  
Connectors

Gehäuse siehe Seite 154-155  
Housings see page 154-155

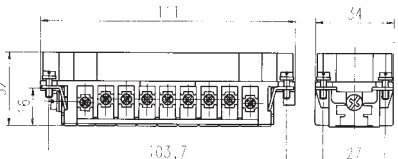
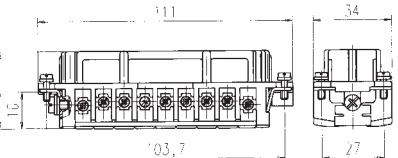
Bezeichnung - Abbildung Description - Figure	Maßzeichnung Drawing	Bestell Nr. / Part No.	
		Stifteinsatz / Male insert	Buchseinsatz / Female insert
Kontakteinsatz Schraubanschluss <sup>1)</sup> Contact insert screw termination <sup>1)</sup>	 Buchseinsatz Female insert 	C146 10A016 102 3  C146 10A016 002 3 (ohne Drahtschutz without wire protection)	C146 10B016 102 3  C146 10B016 002 3 (ohne Drahtschutz without wire protection)

Montageanleitung, Steckbild / Assembly instruction, pin layout

Stifteinsatz  
Male insert

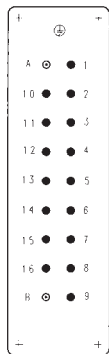

Buchseinsatz  
Female insert

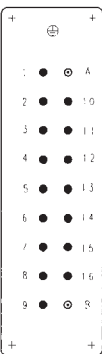

Montageausschnitt (Kontaktträger)  
Panel cut out (insert)

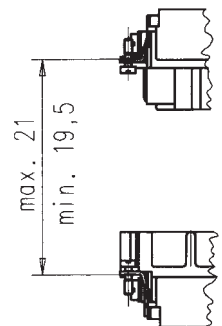
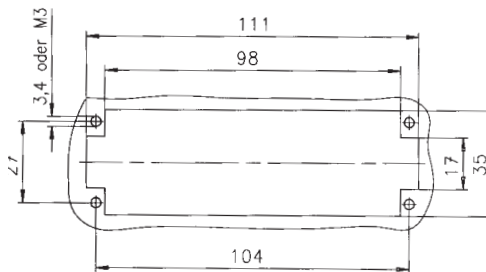

- Arbeitskontakt / working contact
- ⊙ Schaltkontakt / mating contact

Derating Kurve / Derating curve

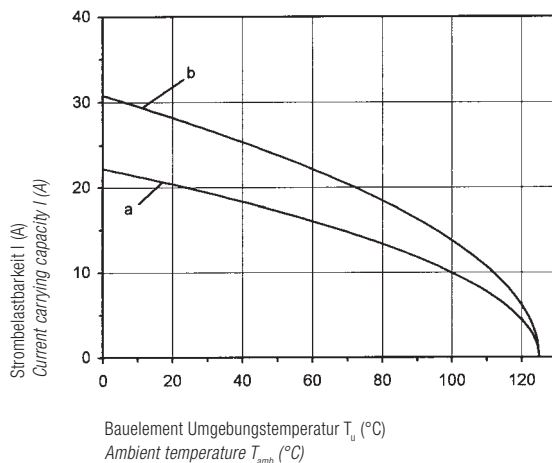















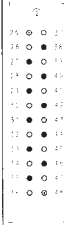

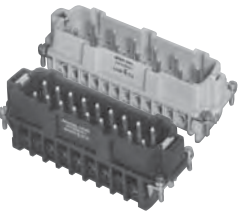
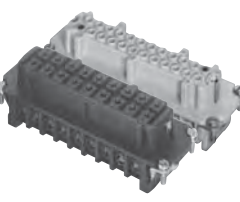

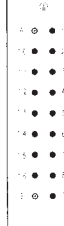
Begrenzung durch Leiter beachten  
Notice restriction of wire

Kurve a Anschlussquerschnitt 1,5 mm<sup>2</sup>  
Curve a wire gauge 1,5 mm<sup>2</sup>

Kurve b Anschlussquerschnitt 2,5 mm<sup>2</sup>  
Curve b wire gauge 2,5 mm<sup>2</sup>

1) mit Drahtschutz / with wire protection

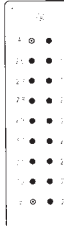
**C 146 HvE****20 +  + 4****26 +  + 4****32 +  + 4****Steckverbinder  
Connectors****660 V~****16 / 22 A****4 nacheilende Schaltkontakte  
4 delayed mating contacts****Gehäuse auf Anfrage  
Housings upon request**

Bezeichnung - Abbildung Description - Figure	Maßzeichnung / Drawing		Bestell Nr. / Part No.	
	Stifteinsatz / Male insert	Buchseinsatz / Female insert	Stifteinsatz / Male insert	Buchseinsatz / Female insert
Kontakteinsätze Schraubanschluss <sup>1)</sup> Contact inserts screw termination <sup>1)</sup> <b>20 +  + 4</b>  	   	<b>C146 10A010 102 3</b> (1 - 24) + <b>C146 10A010 104 3</b> (25 - 48)	<b>C146 10B010 102 3</b> (1 - 24) + <b>C146 10B010 104 3</b> (25 - 48)	
Kontakteinsätze Schraubanschluss <sup>1)</sup> Contact inserts screw termination <sup>1)</sup> <b>26 +  + 4</b>  	   	<b>C146 10A010 102 3</b> (1 - 24) + <b>C146 10A016 102 3</b> (1 - 16)	<b>C146 10A010 102 3</b> (1 - 24) + <b>C146 10B016 102 3</b> (1 - 16)	
Kontakteinsätze Schraubanschluss <sup>1)</sup> Contact inserts screw termination <sup>1)</sup> <b>32 +  + 4</b>  	   	<b>C146 10A016 102 3</b> (1 - 16) + <b>C146 10A016 104 3</b> (17 - 32)	<b>C146 10B016 102 3</b> (1 - 16) + <b>C146 10B016 104 3</b> (17 - 32)	

- Arbeitskontakt / working contact
- ⊙ Schaltkontakt / mating contact
- Leerstelle / without contact

- Arbeitskontakt / working contact
- ⊙ Schaltkontakt / mating contact
- Leerstelle / without contact

- Arbeitskontakt / working contact
- ⊙ Schaltkontakt / mating contact

1) mit Drahtschutz / with wire protection



# C 146 S

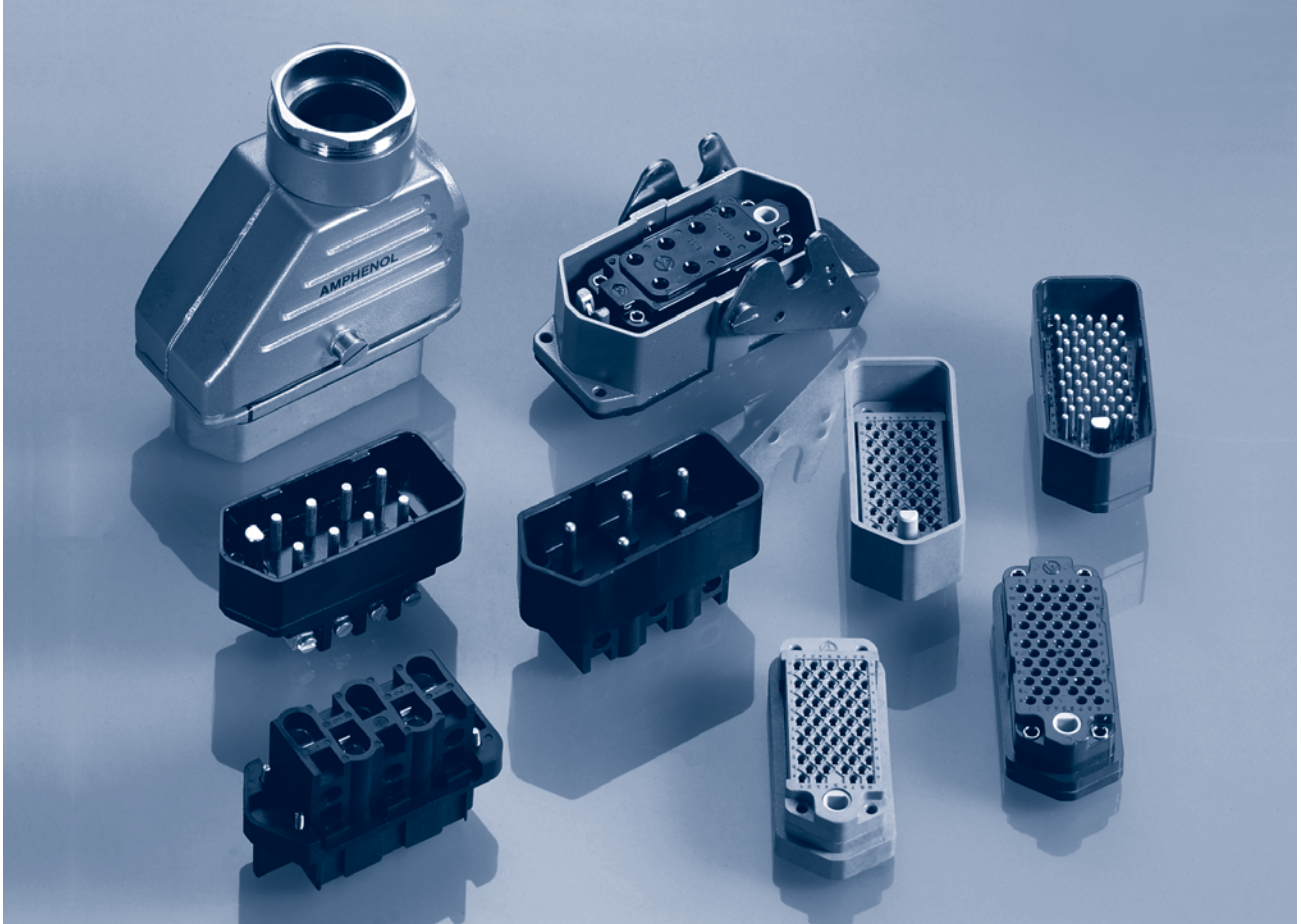

## Hauptmerkmale

- Bemessungsspannung 125 V
- Bemessungsstrom 10 A
- Anschlussart: crimpen
- Polzahl: 57

## Main characteristics

- *Rated voltage 125 V*
- *Rated current 10 A*
- *Termination: crimping*
- *Number of contacts: 57*

### Allgemeine Hinweise



#### General information

- Kontakteinsätze ohne Crimpkontakte (bei Kontakteinsatz mit Crimpanschluss).
- Steckverbinder der Serie C 146 S dürfen nicht unter Last betätigt werden.
- Crimpwerkzeuge siehe separater Katalog „Werkzeuge“.
- Für die Einsätze der Serie C 146 S können sowohl niedrige, wie auch hohe Gehäusebauformen verwendet werden.
- Verarbeitungs- und Montagehinweise von Crimpkontakten, siehe Katalog „Werkzeuge“.

- *Contact inserts without crimp contacts.*
- *Do not mate or unmate A 146 S connectors under electrical load.*
- *Crimping tools see separate catalogue „Tools“.*
- *Low and high profile housings for C 146 S series inserts.*
- *Processing instruction for crimp contacts see catalogue „Tools“.*

### Hoher Schutz vor Fehlsteckungen

#### High protection against mismatching

Buchsenkontakteinsatz mit trichterförmiger, verengter Stecköffnung.  
(hohe Steck- und Kontaktsicherheit)

*Female inserts with funnel shaped contact entry avoids mismatching.  
(high security in mating and contacting)*

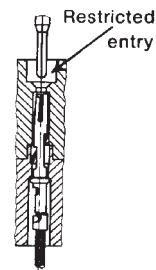

### Voreilender Schutzkontakt (am Kontakteinsatz)

#### First-to-mate last-to-break protective ground contact (at the contact insert)



Allgemeine Kennwerte	General Characteristics	Norm / Standard	Wert / Value
Polzahl	Number of contacts		57 + ⊕
Anschluss technik	Termination technique		crimpen crimp
	Max. wire gauge		2,5 mm <sup>2</sup>
	Protection class		IP 54
Maximaler Leiterquerschnitt	Max. wire diameter		3,5 mm
	Flammability	UL 94	V-1
Elektrische Kennwerte	Electrical Characteristics		
Bemessungsspannung	Rated voltage	IEC 60664-1	150 V
Verschmutzungsgrad	Pollution degree	IEC 60664-1	3
Isolierstoffgruppe	Material group	IEC 60664-1	III a
Bemessungs-Stoßspannung	Rated impulse withstand voltage	IEC 60664-1	3,0 kV
Spannungsfestigkeit	Voltage proof	IEC 60512-2; Test 4 a	1,4 kV
Strombelastbarkeit	Current carrying capacity	IEC 60512-2	siehe Derating Kurven / see derating curves
Durchgangswiderstand	Contact resistance	IEC 60512-2	< 5 m Ω
Isolationswiderstand	Insulation resistance	IEC 60512-2	≥ 10 <sup>10</sup> Ω
Luftstrecke	Clearance	IEC 60664-1	1,6 mm
Kriechstrecke	Creepage	IEC 60664-1	3 mm
Klimatische Kennwerte	Climatical Characteristics		
Prüfklasse	Climatic category	IEC 60068-1	40 / 125 / 21
Mechanische Kennwerte	Mechanical Characteristics		
Gesamt Steck- und Ziehkraft	Insertion and withdrawal forces	IEC 60529	≤ 250 N
<sup>1)</sup> IP-Schutzart Stifteinsatz	IP-degree of protection pin insert	IEC 60529	gesteckt/mated IP20
<sup>1)</sup> IP-Schutzart Buchseneinsatz	IP-degree of protection socket insert	IEC 60529	gesteckt/mated IP20
Gewicht Stifteinsatz	Weight Male insert		60 g
Gewicht Buchseneinsatz	Weight Female insert		55 g
Mechanische Lebensdauer	Mechanical operation		> 500 Steckzyklen / mating cycles
Werkstoffe	Materials		
Kontakteinsatz	Insert		PPO
Schraubkontakte	Screw contacts		CuZn (Messing/brass)
Crimpkontakt Stift	Male crimp contacts		CuZn (Messing/brass)
Crimpkontakt Buchse	Female crimp contacts		CuSn (Zinnbronze / Tin bronze)
Kontakt oberfläche	Contact plating		Ag
Farbe	Colour		grau / grey
Gehäuse	Housings		Aluminium Druckguss / Aluminium die cast
Dichtgummi	Rubber gasket		Neoprene / Neoprene

<sup>1)</sup> IP-Schutzart im Anschlussbereich der Schraub-/Löt ausführung IP 00  
IP-degree of protection on termination side of screw/solder version IP 00

C 146 S



57 + 

125 V~

10 A

Steckverbinder  
Connectors

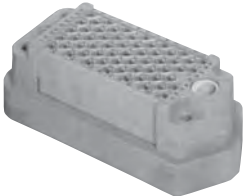
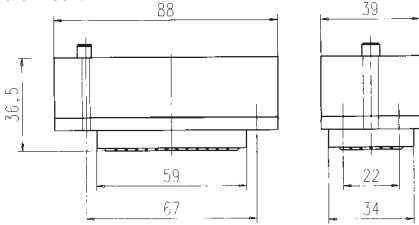
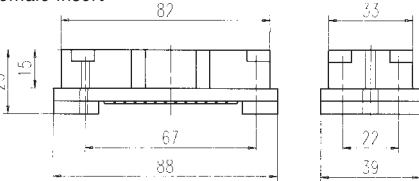
Gehäuse siehe Seite 106  
Housings see page 106

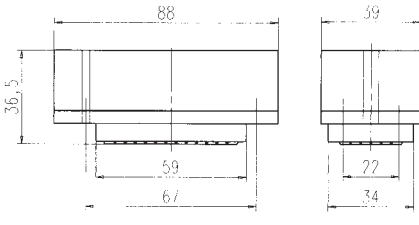
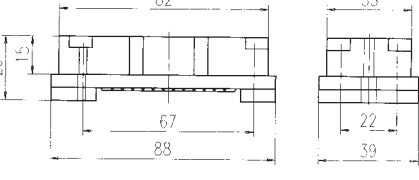
Bezeichnung - Abbildung Description - Figure	Maßzeichnung Drawing	Bestell Nr. / Part No.	
		Stifteinsatz / Male insert	Buchseneinsatz / Female insert
<p>Kontakteinsatz Crimpanschluss mit Kodiereinrichtung 6 Pos. Contact insert crimp termination incl. polarisation 6 Pos.</p>  	<p>Stifteinsatz Male insert</p>  <p>Buchseneinsatz Female insert</p> 	C146 10A057 000 6	C146 10B057 000 6
<p>Kontakteinsatz Crimpanschluss ohne Kodiereinrichtung Contact insert crimp termination without polarisation</p>  	<p>Stifteinsatz Male insert</p>  <p>Buchseneinsatz Female insert</p> 	C146 10A057 801 6	C146 10B057 801 6

C 146 S

57 + 

**Crimpkontakte**  
**Crimp contacts**

Gestanzte Einzelkontakte  
*Stamped single contacts*

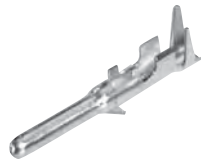

Gestanzte Bandkontakte für Crimpzangen  
*Stamped contacts on reel for hand crimping tools*



200 / 100 Stück  
200 / 100 pcs

Gestanzte Bandkontakte für Crimpmaschinen  
*Stamped contacts on reel for crimp machines*



2000 Stück  
(Zuführung links oder rechts)  
2000 pcs  
(feeding left or right hand side)

Lieferform <i>Supplied as</i>	für Leiterquerschnitt <i>for wire gauge</i>	AWG	Stückzahl <i>Pieces</i>	Bestell Nr. <sup>1)</sup> / Part No. <sup>1)</sup>	
				Stiftkontakt / Male contact	Buchsenkontakt / Female contact
<b>Gestanzte Einzelkontakte / Stamped single contacts</b>					
	0,5 - 1,5 mm <sup>2</sup>	20 - 16	100	VN01 025 0007 (101)	VN02 025 0001 (101)
	1,5 - 2,5 mm <sup>2</sup>	16 - 14	100	VN01 025 0008 (101)	VN02 025 0010 (101)
<b>Gestanzte Bandkontakte für Crimpzangen / Stamped contacts on reel for hand crimping tools</b>					
	0,5 - 1,5 mm <sup>2</sup>	20 - 16	200	ZN01 025 0007 (1)	ZN02 025 0001 (1)
	1,5 - 2,5 mm <sup>2</sup>	16 - 14	100	ZN01 025 0008 (1)	ZN02 025 0010 (1)
<b>Gestanzte Bandkontakte für Crimpmaschinen / Stamped contacts on reel for crimp machines</b>					
Kontaktzuführung rechts <i>Contact feeding right hand side</i>	0,5 - 1,5 mm <sup>2</sup>	20 - 16	2000	HN01 025 0007 (1)	HN02 025 0001 (1)
	1,5 - 2,5 mm <sup>2</sup>	16 - 14	2000	HN01 025 0008 (1)	HN02 025 0010 (1)
Kontaktzuführung links <i>Contact feeding left hand side</i>	0,5 - 1,5 mm <sup>2</sup>	20 - 16	2000	TN01 025 0007 (1)	TN02 025 0001 (1)
	1,5 - 2,5 mm <sup>2</sup>	16 - 14	2000	TN01 025 0008 (1)	TN02 025 0010 (1)

Steckbild / Pin layout

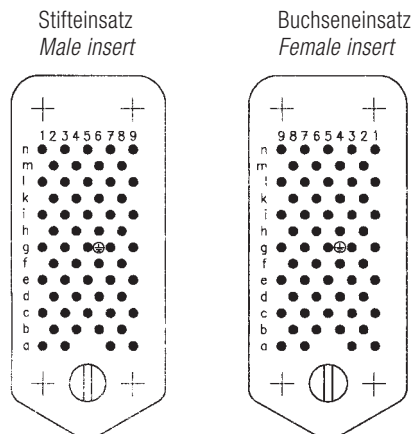

Derating Kurven / Derating curves

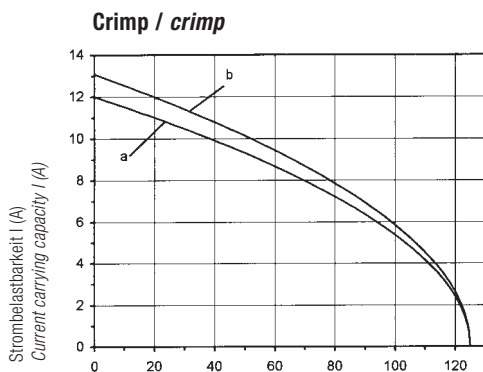

Bauelement Umgebungstemperatur  $T_u$  (°C)  
Ambient temperature  $T_{amb}$  (°C)



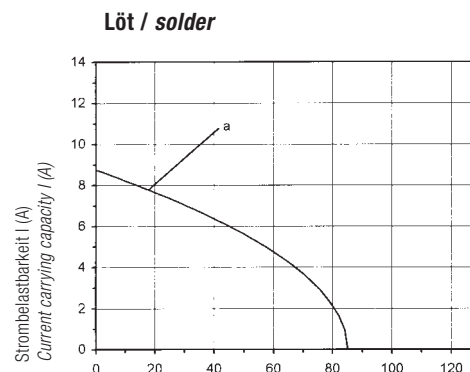

Kurve a Anschlussquerschnitt 1,5 mm<sup>2</sup> / Curve a wire gauge 1,5 mm<sup>2</sup>  
Kurve b Anschlussquerschnitt 2,5 mm<sup>2</sup> / Curve b wire gauge 2,5 mm<sup>2</sup>

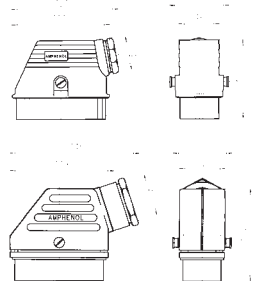

Bauelement Umgebungstemperatur  $T_u$  (°C)  
Ambient temperature  $T_{amb}$  (°C)

<sup>1)</sup> Erläuterung der Bestell-Nr. für die Kontakte siehe Seite 4  
<sup>1)</sup> Explanation of the Part No. for contacts see page 4

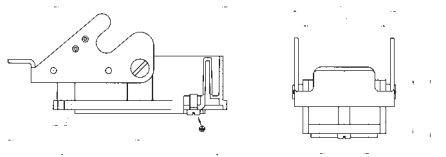
Abisolierlängen siehe S. 198  
Stripping length see p. 198

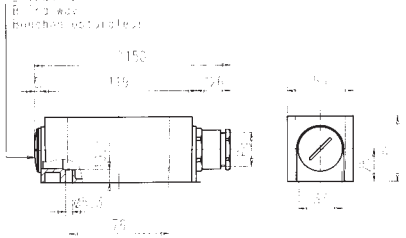
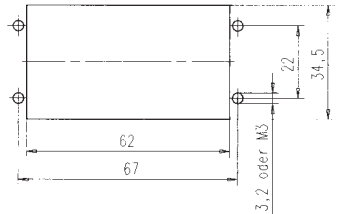
Bezeichnung - Abbildung Description - Figure	Maßzeichnung Drawing	PG	Bestell Nr. / Part No. Niedrige Bauform / Low profile
<b>Gehäuseoberteile / Hoods</b>			
<p>Tüllengehäuse, Abgang Seite Hood, side entry</p> 		21  29  36	<p>T 1860 000</p> <p>T 1860 010</p>
<b>Gehäuseunterteile / Housings</b>			
<p>Anbaugehäuse <sup>1)</sup> Housing bulkhead mounting <sup>1)</sup></p> 		–  –	<p>T 1861 002</p> <p>T 1861 012 (mit Feder am Verriegelungsbügel with spring cover on locking lever)</p>
<p>Sockelgehäuse, 1 Kabelabgang Housing, single side entry</p> 		–	T 1862 001
<b>Montageausschnitt für Anbaugehäuse / Panel cut for housing bulkhead mounting</b>			
			

<sup>1)</sup> incl. Dichtung / incl. gasket



# C 146 Gehäuse / *Housings*

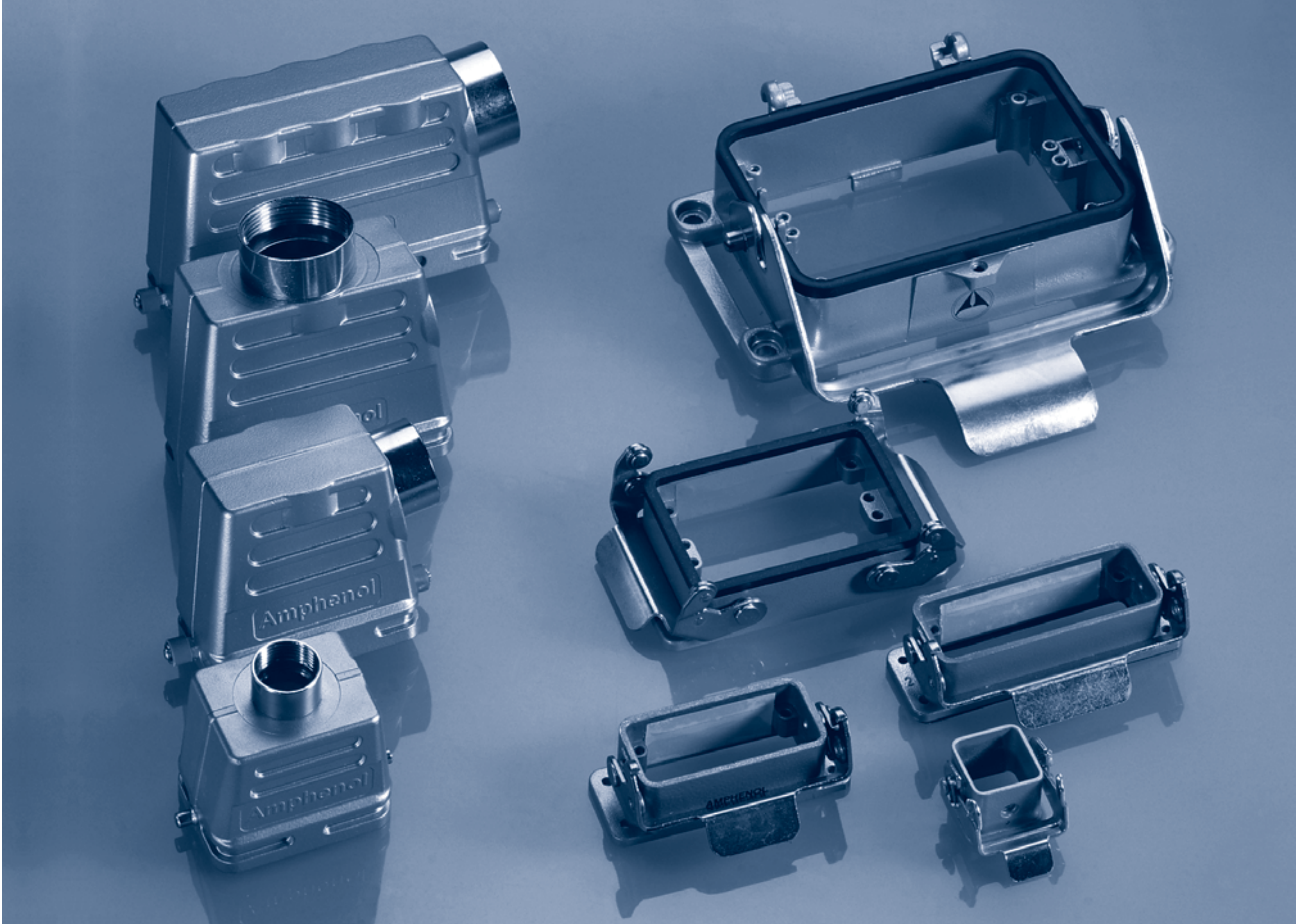

## **Für Serien**

- C 146 D / DD
- C 146 E
- C 146 M
- C 146 A
- C 146 HSE
- C 146 HvE

## ***For series***

- *C 146 D / DD*
- *C 146 E*
- *C 146 M*
- *C 146 A*
- *C 146 HSE*
- *C 146 HvE*

# C 146 Gehäuse Housings

## Kurzinformation Brief information

Allgemeine Hinweise



General information

- Die Steckverbindungen der Serie C 146 sind für Einsatzbereiche im allgemeinen Maschinen-, Anlagen- und Apparatebau, Steuerungs- und Elektrogerätebau vorgesehen. Die Überprüfung, ob die Steckverbindung anderen als den angegebenen Vorschriften entspricht, bzw. ob diese in speziell von uns nicht vorhersehbaren Anwendungsbereichen eingesetzt werden kann, obliegt dem Anwender.
  - Bei Kupplungsgehäusen ist eine ausreichende Zugentlastung sicherzustellen.
  - Bei Einsatz von Gehäusen ohne Stützen wird der Kabelraum beeinträchtigt.
  - Die angegebenen Bemaßungen bei den Montageausschnitten stellen Anhaltswerte dar und sind im konkreten Anwendungsfall auf die Produkte abzustimmen.
  - Die Dichtfläche bei den Anbaugehäusen muss eben und gratfrei sein.
- *The connectors of our C 146 series are designed for use in machine tools, general electric installations and applications as well as for industrial control and other electrical equipment. Other applications than the above mentioned are in the responsibility of the user.*
  - *For cable to cable connections a suitable cable clamp has to be used.*
  - *The use of housings without stud impairs the cable room.*
  - *The indicated dimensions with the panel cut-outs represent reference values and are in the concrete application with products to be co-ordinated.*
  - *The sealing area of the housing has to be level and free of burrs.*

Große Gehäuseauswahl  
in 2 Bauhöhen

Large range of housings  
in 2 different heights



Genormte Steckverbindergehäuse  
nach DIN 43652  
DIN EN 175 301-801 (DIN 43652)

Standardised connector housings  
according DIN 43652  
DIN EN 175 301-801 (DIN 43652)

Weitere Sonderausführung  
auf Anfrage

Special housing on request



z. B. Korrosions geschützte Gehäuse  
e. G. corrosion protected housings



Sondertypen  
Customer specials

## C 146 Gehäuse Housings











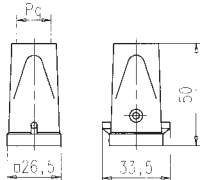

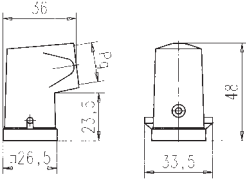
### Technische Daten Characteristics

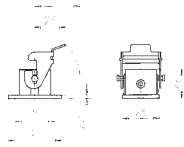
<b>Allgemeine Kennwerte</b>	<b>General Characteristics</b>	<b>Norm / Standard</b>	<b>Wert / Value</b>
Schutzart Gehäuse	<i>Protection class housing</i>		IP 65
Schutzart Klappdeckel verriegelt unverriegelt	<i>Protetion class spring cover locked spring loaded</i>		IP 65 IP 54
Verriegelungssystem	<i>Locking system</i>	DIN EN 175 301-801 (DIN 43 652)	1 Längsbügel / <i>1 locking lever</i> 2 Querbügel / <i>2 locking levers</i>
<b>Klimatische Kennwerte</b>	<b>Climatical Characteristics</b>		
Prüfklasse	<i>Climatic category</i>	IEC 60068-1	40 / 100 / 21
Temperaturbereich	<i>Temperature range</i>	IEC 60068-1	- 40 °C / + 100 °C
Obere Grenztemperatur	<i>Upper temperature</i>	IEC 60512-6; Test 11 i	+ 100 °C / 1000 h
Untere Grenztemperatur	<i>Lower temperature</i>	IEC 60512-6; Test 11 i	- 40 °C
<b>Mechanische Kennwerte</b>	<b>Mechanical Characteristics</b>		
Mechanische Lebensdauer	<i>Mechanical operation</i>	IEC 60512-5; Test 9 a	≥ 500 Zyklen / <i>cycles</i>
<b>Werkstoffe</b>	<b>Materials</b>		
Gehäuse	<i>Housings</i>	DIN EN 175 301-801 (DIN 43 652)	Aluminium-Druckguss <i>Aluminium die cast alloy</i>
Kunststoffgehäuse	<i>Thermoplastic housing</i>		PA
Metallgehäuse D 7	<i>Metal housing D 7</i>		Zink-Druckguss / <i>Zinc die cast alloy</i>
Schutzkappe	<i>Protective cover</i>		PA
Dichtgummi	<i>Rubber gasket</i>		NBR
Verriegelung	<i>Locking lever</i>		Stahl / verzinkt <i>steel / zinc coated</i>
Oberfläche EMV Gehäuse	<i>Surface EMV housings</i>		Spezialbeschichtung / <i>special surface</i>

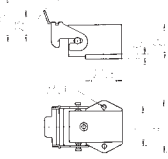
C 146 D 7 pol.  
C 146 A 3/4 pol.

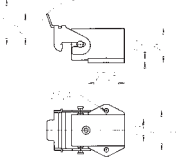
Gehäuse Kunststoff  
Housings thermoplastic

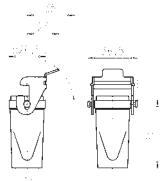

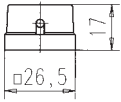







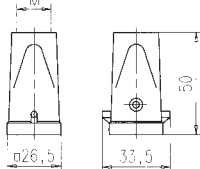

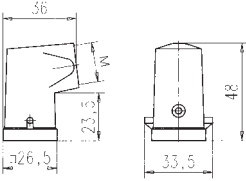
PG-Gewinde  
PG-thread

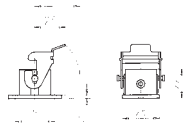
Bezeichnung - Abbildung Description - Figure	Maßzeichnung Drawing	PG	Bestell Nr. Part No.
<b>Gehäuseoberteile / Hoods</b>			
Tüllengehäuse, gerader Kabelausgang Hood, top entry 		11	C146 10G003 600 4
Tüllengehäuse, seitlicher Kabelausgang Hood, side entry 		11	C146 10G003 500 4
<b>Gehäuseunterteile / Housings</b>			
Anbaugehäuse (incl. Flachdichtung) Housing bulkhead mounting (incl. gasket) 	 Montageausschnitt/panel cut out: 22 x 22 mm	–	C146 10F003 000 4
Anbaugehäuse (incl. Flachdichtung) Housing bulkhead end mounting (incl. gasket) 	 Montageausschnitt/panel cut out: 22 x 22 mm	–	C146 10F003 004 4
Sockelgehäuse, 1 Kabelausgang Housing, single side entry 	 Montageausschnitt/panel cut out: 22 x 22 mm	11	C146 10F003 500 4
Kupplungsgehäuse, 1 Kabelausgang Hood, cable to cable coupling 		11	C146 10G003 804 4
<b>Schutzkappen / Protective cover</b>			
Schutzkappe für Gehäuseunterteile (nur in Verbindung mit Stifteinsatz) Cover for housings (only in connection with male insert) 		–	C146 10Z003 100 4

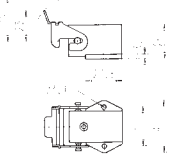
C 146 D 7 pol.  
C 146 A 3/4 pol.

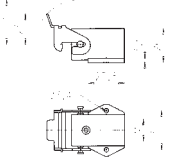
Gehäuse Kunststoff  
Housings thermoplastic

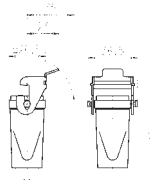

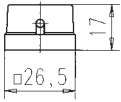







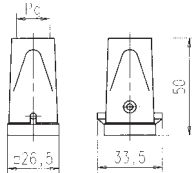

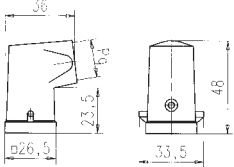
Metrisches Gewinde  
Metric thread

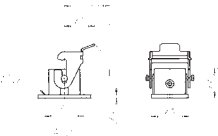
Bezeichnung - Abbildung Description - Figure	Maßzeichnung Drawing	M	Bestell Nr. / Part No.	
			mit Stützen / with stud	ohne Stützen / without stud
<b>Gehäuseoberteile / Hoods</b>				
Tüllengehäuse, gerader Kabelausgang Hood, top entry 		20	C146 10R003 600 4 (grau)	
		20	C146 16R003 600 4 (sw)	
Tüllengehäuse, seitlicher Kabelausgang Hood, side entry 		20	C146 10R003 500 4 (grau)	
		20	C146 16R003 500 4 (sw)	
<b>Gehäuseunterteile / Housings</b>				
Anbaugehäuse (incl. Flachdichtung) Housing bulkhead mounting (incl. gasket) 	 Montageausschnitt/panel cut out: 22 x 22 mm	–	C146 10F003 000 4 (grau)	
			C146 16F003 000 4 (sw)	
Anbaugehäuse (incl. Flachdichtung) Housing bulkhead end mounting (incl. gasket) 	 Montageausschnitt/panel cut out: 22 x 22 mm	–	C146 10F003 004 4	
Sockelgehäuse, 1 Kabelausgang Housing, single side entry 	 Montageausschnitt/panel cut out: 22 x 22 mm	20	C146 10N003 500 4 (grau) mit Verschraubung/ with gland bushing	
		20	C146 16N003 500 4 (sw) mit Verschraubung/ with gland bushing	
Kupplungsgehäuse, 1 Kabelausgang Hood, cable to cable coupling 		20	C146 10R003 804 4	
<b>Schutzkappen / Protective cover</b>				
Schutzkappe für Gehäuseunterteile (nur in Verbindung mit Stifteinsatz) Cover for housings (only in connection with male insert) 		–	C146 10Z003 100 4	

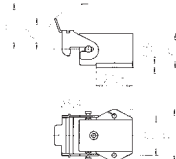
C 146 D 7 pol.  
C 146 A 3/4 pol.

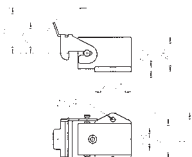
Gehäuse Metall  
Housings metal

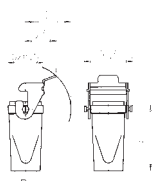
PG-Gewinde  
PG-thread

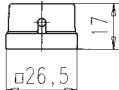
Bezeichnung - Abbildung Description - Figure	Maßzeichnung Drawing	PG	Bestell Nr. Part No.
<b>Gehäuseoberteile / Hoods</b>			
Tüllengehäuse, gerader Kabelausgang Hood, top entry 		11	C146 30G003 600 4
Tüllengehäuse, seitlicher Kabelausgang Hood, side entry 		11	C146 30G003 500 4
<b>Gehäuseunterteile / Housings</b>			
Anbaugehäuse (incl. Flachdichtung) Housing bulkhead mounting (incl. gasket) 		-	C146 30F003 000 4
Anbaugehäuse (incl. Flachdichtung) Housing bulkhead end mounting (incl. gasket) 		-	C146 30F003 004 4
Sockelgehäuse, 1 Kabelausgang Housing, single side entry 		11	C146 30F003 500 4
Kupplungsgehäuse, 1 Kabelausgang Hood, cable to cable coupling 		11	C146 30G003 804 4
<b>Schutzkappen / Protective cover</b>			
Schutzkappe für Gehäuseunterteile (nur in Verbindung mit Stifteinsatz) Cover for housings (only in connection with male insert) 		-	C146 30Z003 100 4











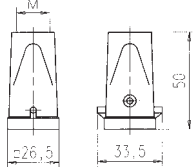

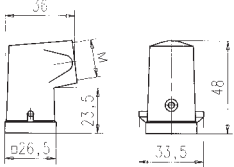
Verschraubung für Tüllen- und Sockelgehäuse siehe Seite 170 - 173 / gland bushings for hoods and housing see page 170-173

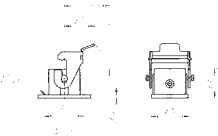

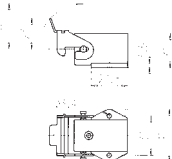
C 146 D 7 pol.  
C 146 A 3/4 pol.

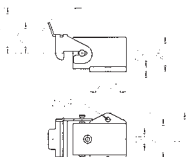
Gehäuse Metall (metrisch)  
Housings metal (metric)

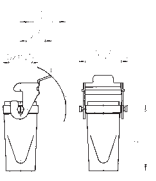
Metrisches Gewinde  
Metric thread

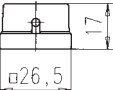





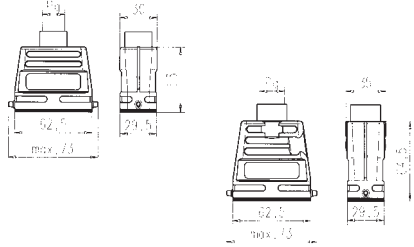

Bezeichnung - Abbildung Description - Figure	Maßzeichnung Drawing	M	Bestell Nr. / Part No.	
			mit Stützen / with stud	ohne Stützen / without stud
<b>Gehäuseoberteile / Hoods</b>				
Tüllengehäuse, gerader Kabelausgang Hood, top entry 		20	C146 30R003 600 4	
Tüllengehäuse, seitlicher Kabelausgang Hood, side entry 		20	C146 30R003 500 4	
<b>Gehäuseunterteile / Housings</b>				
Anbaugehäuse (incl. Flachdichtung) Housing bulkhead mounting (incl. gasket) 		-	C146 30F003 000 4	
Anbaugehäuse (incl. Flachdichtung) Housing bulkhead end mounting (incl. gasket) 		-	C146 30F003 004 4	
Sockelgehäuse, 1 Kabelausgang Housing, single side entry 		20	C146 30N003 500 4	C146 31N003 500 4
Kupplungsgehäuse, 1 Kabelausgang Hood, cable to cable coupling 		20	C146 30R003 804 4	
<b>Schutzkappen / Protective cover</b>				
Schutzkappe für Gehäuseunterteile (nur in Verbindung mit Stifteinsatz) Cover for housings (only in connection with male insert) 		-	C146 30Z003 100 4	

**C 146 D 15 pol.**  
**C 146 A 10 pol.**

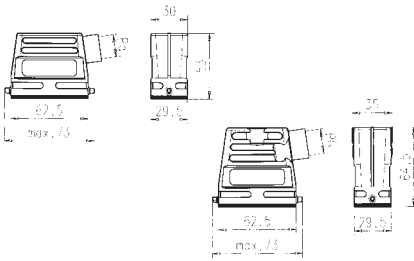
nach  
DIN EN 175 301 - 801 (DIN 43 652)

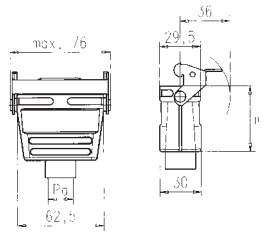
**Gehäuse**  
**Housings**

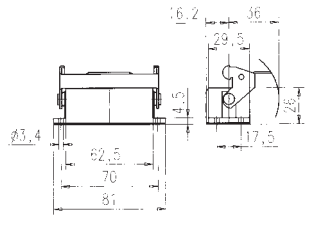
**PG-Gewinde**  
**PG-thread**

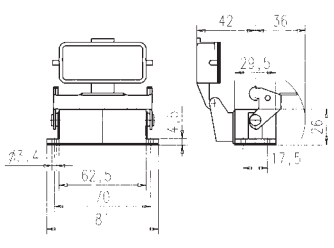
Bezeichnung - Abbildung <i>Description - Figure</i>	Maßzeichnung <i>Drawing</i>	PG	Bestell Nr. / <i>Part No.</i>		
			Niedrige Bauform/ <i>Low profile</i>	Hohe Bauform/ <i>High profile</i>	
<b>Gehäuseoberteile / Hoods</b>					
Tüllengehäuse, Abgang oben <i>Hood, top entry</i> 		13,5	C146 10G010 600 4		
		16	C146 10G010 601 4		
		16		C146 10G015 601 2	
		21		C146 10G015 600 2	
Tüllengehäuse, Abgang Seite <i>Hood, side entry</i> 		13,5	C146 10G010 501 4		
		16	C146 10G010 500 4		
		16		C146 10G015 501 2	
		21		C146 10G015 500 2	
<b>Gehäuseunterteile / Housings</b>					
Kupplungsgehäuse <i>Hood, coupling application</i> 		h			
		47,5	13,5	C146 10G010 804 4	
		47,5	16	C146 10G010 805 4	
		59	21	C146 10G015 804 2	
Anbaugehäuse <sup>1)</sup> <i>Housing, bulkhead mounting</i> 				C146 10F015 000 2	
Anbaugehäuse, mit Klappdeckel <sup>1)</sup> <i>Housing, bulkhead mounting, with spring cover</i> 				C146 10F015 003 2	

<sup>1)</sup> incl. Flachdichtung / *incl. gasket*

**Metrisches Gewinde**  
**Metric thread**





Maßzeichnung Drawing	M	Bestell Nr. / Part No.		Bestell Nr. / Part No.	
		Niedrige Bauform/ Low profile	Hohe Bauform/ High profile	Niedrige Bauform/ Low profile	Hohe Bauform/ High profile
		mit Stützen / with stud		ohne Stützen / without stud	
	20	C146 10R010 650 4		C146 21R010 650 4	
	25	C146 10R010 600 4		C146 21R010 600 4	
	20		C146 10R015 650 2		C146 21R015 650 2
	25		C146 10R015 600 2		C146 21R015 600 2
	20	C146 10R010 550 4		C146 21R010 550 4	
	25	C146 10R010 500 4		C146 21R010 500 4	
	20		C146 10R015 550 2		C146 21R015 550 2
	25		C146 10R015 500 2		C146 21R015 500 2
	h				
	47,5	20	C146 10R010 854 4		C146 21R010 854 4
	47,5	25	C146 10R010 804 4		C146 21R010 804 4
	59	20		C146 10R015 854 2	
	25		C146 10R015 804 2		C146 21R015 804 2
		-	C146 10F015 000 2		
			C146 10F015 003 2		

C 146 D 15 pol.  
C 146 A 10 pol.

nach  
DIN EN 175 301 - 801 (DIN 43 652)

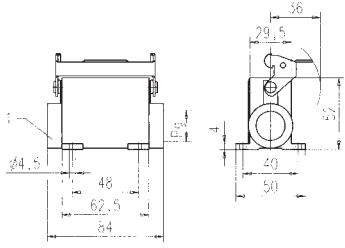
Gehäuse  
Housings

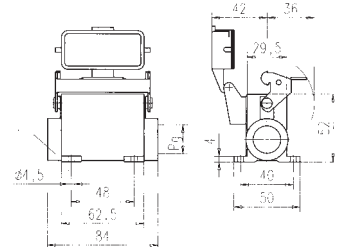
PG-Gewinde  
PG-thread

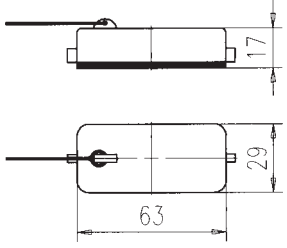
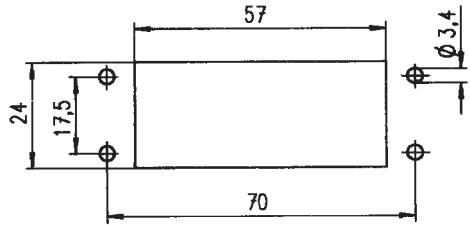
Bezeichnung - Abbildung Description - Figure	Maßzeichnung Drawing	PG	Bestell Nr. / Part No.	
			1 Kabelabgang single side entry	2 Kabelabgänge double side entry
<b>Gehäuseunterteil / Housings</b>				
Sockelgehäuse Housing  	 <p>1 Geschlossen bei einem Kabelausgang 1 closed if single entry</p>	16	C146 10F015 501 2	C146 10F015 601 2
		21	C146 10F015 500 2	C146 10F015 600 2
Sockelgehäuse mit Klappdeckel Housing with spring cover  	 <p>1 Geschlossen bei einem Kabelausgang 1 closed if single entry</p>	16	C146 10F015 807 2	C146 10F015 607 2
		21	C146 10F015 806 2	C146 10F015 606 2
<b>Schutzkappen / Protective cover</b>				
Schutzkappe für Gehäuseunterteile Cover for housings  		-	C146 10Z015 100 2	
<b>Montageausschnitt / Panel cut out</b>				
				

Verschraubung für Tüllen- und Sockelgehäuse siehe Seite 170-173 / gland bushings for hoods and housing see page 170-173

according to  
DIN EN 175 301 - 801 (DIN 43 652)

**Metrisches Gewinde**  
**Metric thread**

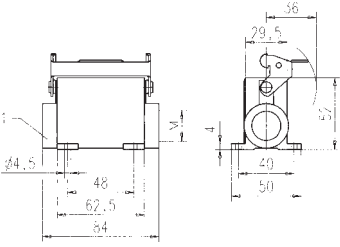
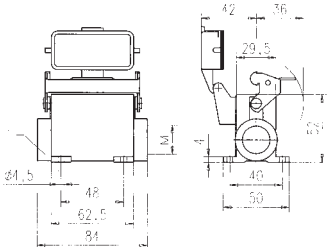
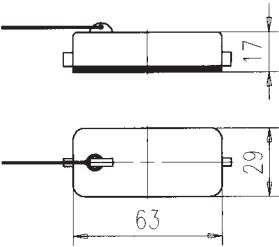
Maßzeichnung Drawing	M	Bestell Nr. / Part No.			
		1 Kabelabgang single side entry	2 Kabelabgänge double side entry	2 Kabelabgänge (rechts + unten) double side entry (right + bottom)	
 <p>1 Geschlossen bei einem Kabelausgang 1 closed if single entry</p>	20	C146 10N015 501 2	C146 10N015 601 2	C146 10N015 703 2	
	20				
	20				
		25	C146 10N015 500 2	C146 10N015 600 2	C146 10N015 702 2
		25			
		25			
 <p>1 Geschlossen bei einem Kabelausgang 1 closed if single entry</p>	20	C146 10N015 807 2	C146 10N015 607 2	C146 10N015 709 2	
	20				
	20				
		25	C146 10N015 806 2	C146 10N015 606 2	C146 10N015 708 2
		25			
		25			
	-		C146 10Z015 100 2		

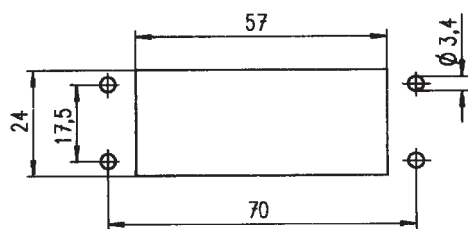







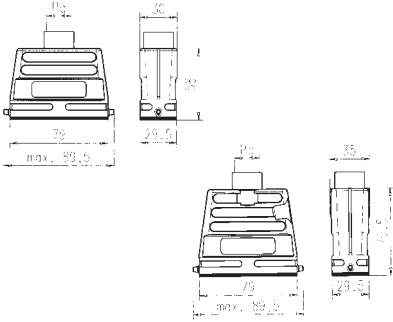

C 146 D 25 pol.  
C 146 A 16 pol.

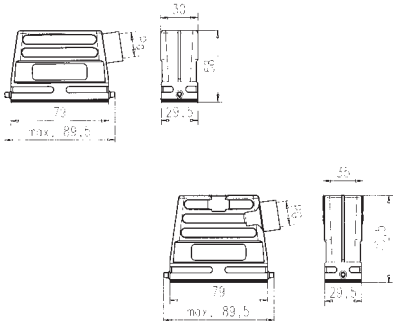
nach  
DIN EN 175 301 - 801 (DIN 43 652)

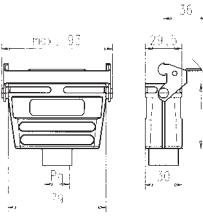
Gehäuse  
Housings

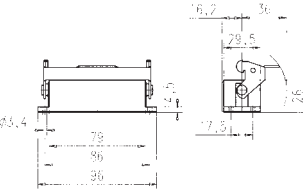
PG-Gewinde  
PG-thread

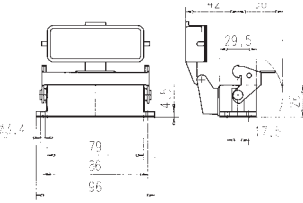
Bezeichnung - Abbildung Description - Figure	Maßzeichnung Drawing	PG	Bestell Nr. / Part No.	
			Niedrige Bauform/ Low profile	Hohe Bauform/ High profile
<b>Gehäuseoberteile / Hoods</b>				
Tüllengehäuse, Abgang oben Hood, top entry 		16	C146 10G016 600 4	
		16		C146 10G025 601 2
		21		C146 10G025 600 2
Tüllengehäuse, Abgang Seite Hood, side entry 		13,5	C146 10G016 501 4	
		16	C146 10G016 500 4	
		16		C146 10G025 501 2
		21		C146 10G025 500 2
<b>Gehäuseunterteile / Housings</b>				
Kupplungsgehäuse Hood, coupling application 		h		
		52,5	13,5	C146 10G016 805 4
		52,5	16	C146 10G016 804 4
		65	21	C146 10G025 804 2
Anbaugehäuse <sup>1)</sup> Housing, bulkhead mounting 		—	C146 10F025 000 2	
Anbaugehäuse, mit Klappdeckel <sup>1)</sup> Housing, bulkhead mounting, with spring cover 		—	C146 10F025 003 2	

<sup>1)</sup> incl. Flachdichtung / incl. gasket



according to  
DIN EN 175 301 - 801 (DIN 43 652)

**Metrisches Gewinde**  
**Metric thread**





Maßzeichnung Drawing	M	Bestell Nr. / Part No.		Bestell Nr. / Part No.		
		Niedrige Bauform/ Low profile	Hohe Bauform/ High profile	Niedrige Bauform/ Low profile	Hohe Bauform/ High profile	
		mit Stützen / with stud		ohne Stützen / without stud		
	20	C146 10R016 650 4		C146 21R016 650 4		
	25	C146 10R016 600 4		C146 21R016 600 4		
	20		C146 10R025 650 2		C146 21R025 650 2	
	25		C146 10R025 600 2		C146 21R025 600 2	
	20	C146 10R016 550 4		C146 21R016 550 4		
	25	C146 10R016 500 4		C146 21R016 500 4		
	20		C146 10R025 550 2		C146 21R025 550 2	
	25		C146 10R025 500 2		C146 21R025 500 2	
	52,5	20	C146 10R016 854 4		C146 21R016 854 4	
	65	25	C146 10R016 804 4		C146 21R016 804 4	
	52,5	20		C146 10R025 854 2		C146 21R025 854 2
	65	25		C146 10R025 804 2		C146 21R025 804 2
	-		C146 10F025 000 2			
		-		C146 10F025 003 2		

**C 146 D 25 pol.  
C 146 A 16 pol.**

nach  
DIN 43 652 (CECC 75 301 - 801; EN 175 301 - 801)

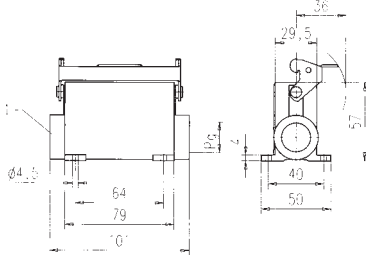
**Gehäuse  
Housings**

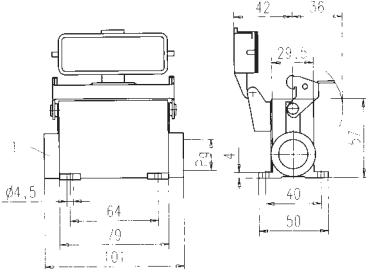
**PG-Gewinde  
PG-thread**

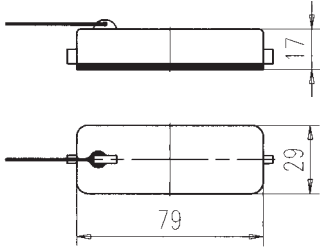
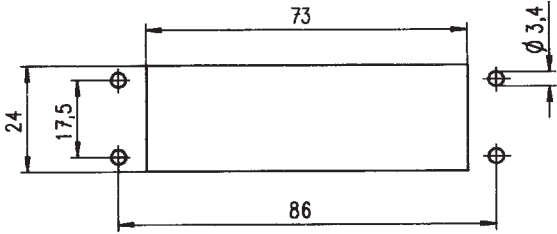
Bezeichnung - Abbildung <i>Description - Figure</i>	Maßzeichnung <i>Drawing</i>	PG	Bestell Nr. / <i>Part No.</i>	
			1 Kabelabgang <i>single side entry</i>	2 Kabelabgänge <i>double side entry</i>
<b>Gehäuseunterteil / Housings</b>				
Sockelgehäuse <i>Housing</i> 	 <p>1 Geschlossen bei einem Kabelausgang <i>1 closed if single entry</i></p>	16  21	C146 10F025 501 2  C146 10F025 500 2	C146 10F025 601 2  C146 10F025 600 2
Sockelgehäuse mit Klappdeckel <i>Housing with spring cover</i> 	 <p>1 Geschlossen bei einem Kabelausgang <i>1 closed if single entry</i></p>	16  21	C146 10F025 807 2  C146 10F025 806 2	C146 10F025 607 2  C146 10F025 606 2
<b>Schutzkappen / Protective cover</b>				
Schutzkappe für Gehäuseunterteile <i>Cover for housings</i> 		-	C146 10Z025 100 2	
<b>Montageausschnitt / Panel cut out</b>				
				

PG Verschraubung für Tüllen- und Sockelgehäuse siehe Seite 170-173 / PG gland bushings for hoods and housing see page 170-173  
Bei Sockelgehäusen Abgang rechts dargestellt / housings are shown with right outlet

according to  
DIN 43 652 (CECC 75 301 - 801; EN 175 301 - 801)



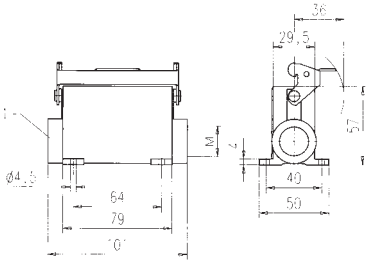
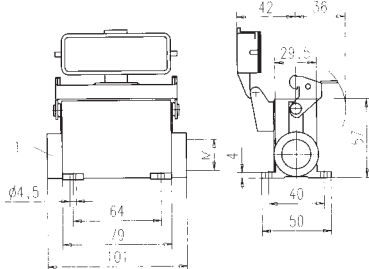
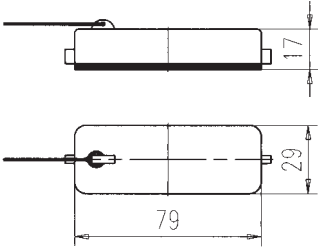
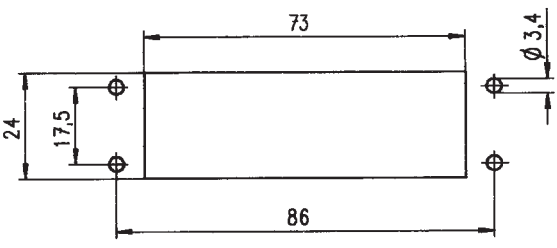



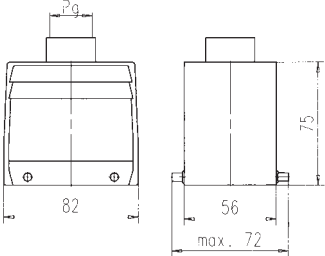

**Metrisches Gewinde**  
**Metric thread**

Maßzeichnung <i>Drawing</i>	M	Bestell Nr. / Part No.				
		1 Kabelabgang <i>single side entry</i>	2 Kabelabgänge <i>double side entry</i>	2 Kabelabgänge (rechts + unten) <i>double side entry (right + bottom)</i>		
 <p>1 Geschlossen bei einem Kabelausgang 1 closed if single entry</p>	20	C146 10N025 501 2	C146 10N025 601 2	C146 10N025 703 2		
	20					
	20					
		25	C146 10N025 500 2	C146 10N025 600 2	C146 10N025 702 2	
		25				
		25				
 <p>1 Geschlossen bei einem Kabelausgang 1 closed if single entry</p>	20	C146 10N025 807 2	C146 10N025 607 2	C146 10N025 709 2		
	20					
	20					
		25	C146 10N025 806 2	C146 10N025 606 2	C146 10N025 708 2	
		25				
		25				
	—	C146 10Z025 100 2				
						

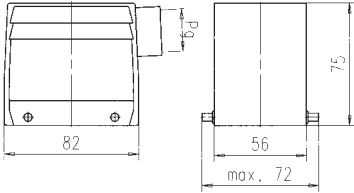
C 146 D 50 pol.  
C 146 A 32 pol.

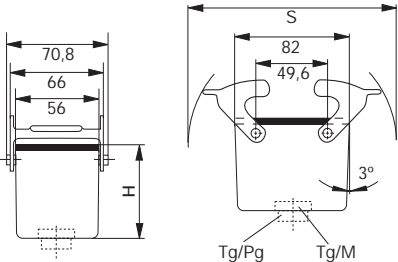
Gehäuse  
Housings

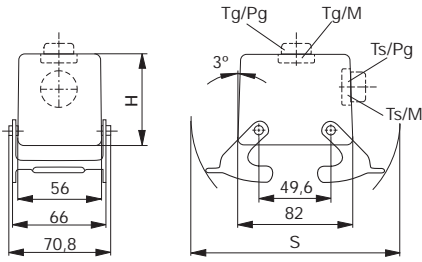
PG-Gewinde  
PG-thread

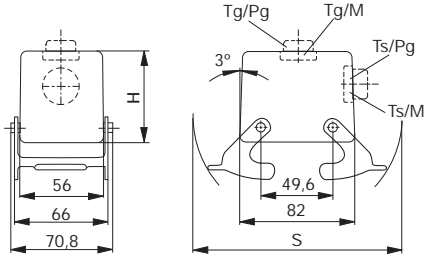





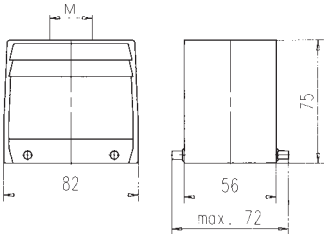

Bezeichnung - Abbildung Description - Figure	Maßzeichnung Drawing	PG	Bestell Nr. Part No.
<b>Gehäuseoberteile / Hoods</b>			
Tüllengehäuse, Abgang oben <i>Hood, top entry</i> 		21	C146 10G032 600 4
Tüllengehäuse, Abgang Seite <i>Hood, side entry</i> 		21	C146 10G032 500 4
Kupplungsgehäuse <i>Hood, coupling application</i> 			
Tüllengehäuse, Abgang oben <i>Hood, top entry</i> 			
Tüllengehäuse, Abgang Seite <i>Hood, side entry</i> 			

Verschraubung für Tüllen- und Sockelgehäuse siehe Seite 170-173 / gland bushings for hoods and housing see page 170-173

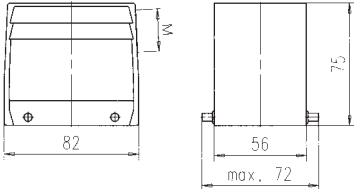
**C 146 D 50 pol.**  
**C 146 A 32 pol.**

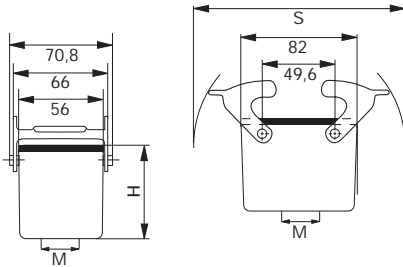
**Gehäuse**  
**Housings**

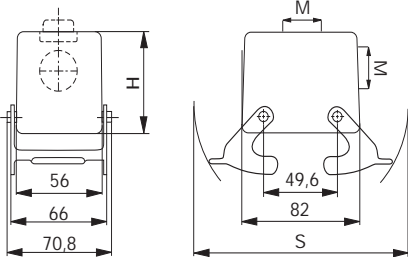

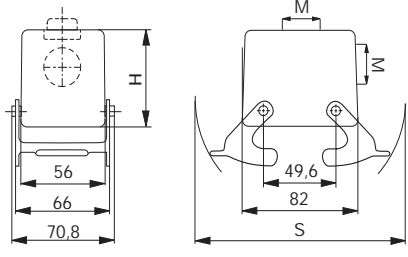

**Metrisches Gewinde**  
**Metric thread**

Bezeichnung - Abbildung <i>Description - Figure</i>	Maßzeichnung <i>Drawing</i>	M	Bestell Nr. <i>Part No.</i>
<b>Gehäuseoberteile / Hoods</b>		<b>ohne Stützen / without stud</b>	
Tüllengehäuse, Abgang oben <i>Hood, top entry</i>  		25	C146 21R032 650 4
		32	C146 21R032 600 4
		40	C146 21R032 601 4
Tüllengehäuse, Abgang Seite <i>Hood, side entry</i>  		25	C146 21R032 550 4
		32	C146 21R032 500 4
		40	C146 21R032 501 4
Kupplungsgehäuse <i>Hood, coupling application</i>  		25	C146 21R032 852 4
		32	C146 21R032 802 4
		40	C146 21R032 803 4
Tüllengehäuse, Abgang oben <i>Hood, top entry</i>  		25	C146 21R032 652 4
		32	C146 21R032 602 4
		40	C146 21R032 603 4
Tüllengehäuse, Abgang Seite <i>Hood, side entry</i>  		25	C146 21R032 552 4
		32	C146 21R032 502 4
		40	C146 21R032 503 4

**C 146 D 50 pol.**  
**C 146 A 32 pol.**

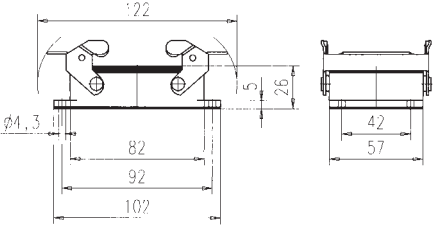
**Gehäuse**  
**Housings**

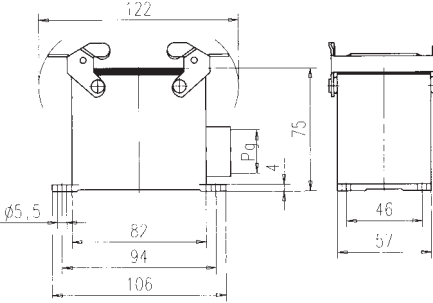
**PG-Gewinde**  
**PG-thread**

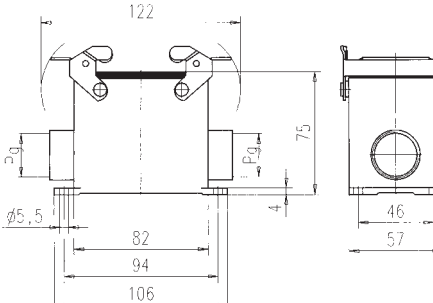
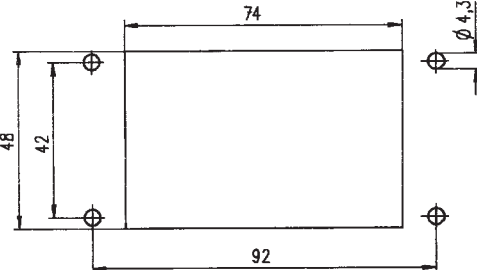
Bezeichnung - Abbildung Description - Figure	Maßzeichnung Drawing	PG	Bestell Nr. Part No.
<b>Gehäuseunterteile / Housings</b>			
Anbaugehäuse <sup>1)</sup> Housing, bulkhead mounting 		-	C146 10F032 000 4
Anbaugehäuse <sup>1)</sup> mit Bolzen und Klappdeckel Housing <sup>1)</sup> , bulkhead mounting and with spring cover		-	C146 10F032 002 4
Sockelgehäuse, 1 Kabelabgang Housing, single side entry 		21  29	C146 10F032 500 4  C146 10F032 501 4
Sockelgehäuse, 2 Kabelabgänge Housing, double side entry 		21  29	C146 10F032 600 4  C146 10F032 601 4
<b>Montageausschnitt / Panel cut out</b>			
			





<sup>1)</sup> incl. Flachdichtung / incl. gasket  
 Bei Sockelgehäusen Abgang rechts dargestellt / housings are shown with right outlet

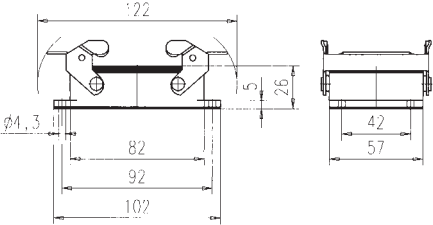

**C 146 D 50 pol.**  
**C 146 A 32 pol.**

**Gehäuse**  
**Housings**

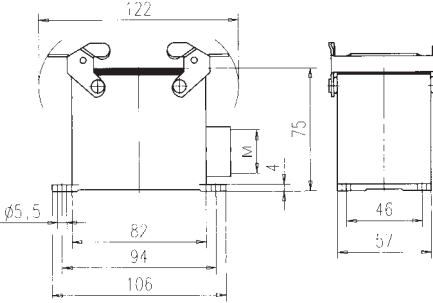
**Metrisches Gewinde**  
**Metric thread**

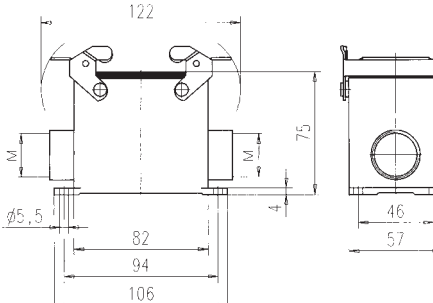
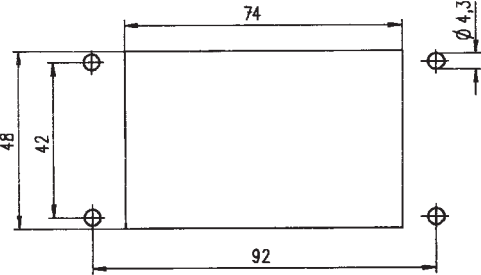





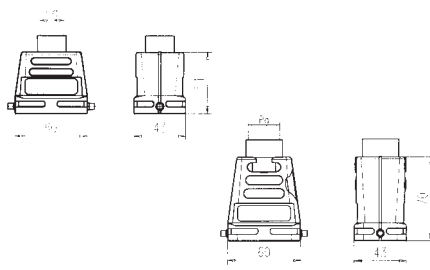

Bezeichnung - Abbildung Description - Figure	Maßzeichnung Drawing	M	Bestell Nr. Part No.
<b>Gehäuseunterteile / Housings</b>		<b>mit Stützen / with stud</b>	
Anbaugehäuse <sup>1)</sup> Housing, bulkhead mounting 		-	C146 10F032 000 4
Anbaugehäuse <sup>1)</sup> mit Bolzen und Klappdeckel Housing <sup>1)</sup> , bulkhead mounting and with spring cover		-	C146 10F032 002 4
Sockelgehäuse, 1 Kabelabgang Housing, single side entry 		25  32  40	C146 10N032 550 4  C146 10N032 500 4  C146 10N032 501 4
Sockelgehäuse, 2 Kabelabgänge Housing, double side entry 		25  32  40	C146 10N032 650 4  C146 10N032 600 4  C146 10N032 601 4
<b>Montageausschnitt / Panel cut out</b>			
			

C 146 E 6 pol.  
 C 146 M 2 Module  
 C 146 DD 24 pol.  
 C 146 EE 10 pol.

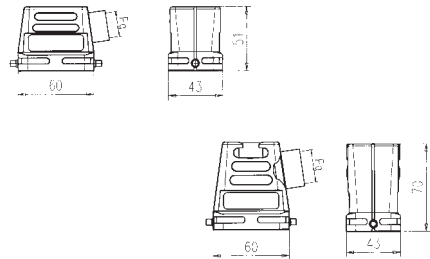
Gehäuse für Längsbügelverriegelung  
 in Anlehnung an  
 DIN EN 175 301 - 801 (DIN 43 652)

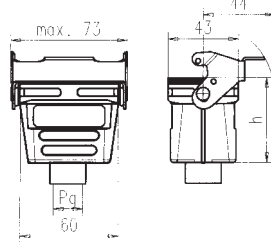
Gehäuse  
 Housings

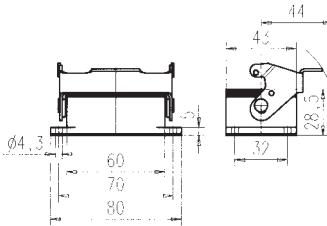
PG-Gewinde  
 PG-thread

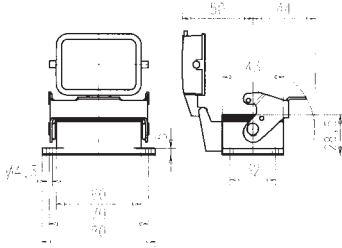
Bezeichnung - Abbildung Description - Figure	Maßzeichnung Drawing	PG	Bestell Nr. / Part No.		
			Niedrige Bauform / Low profile	Hohe Bauform / High profile	
<b>Gehäuseoberteile / Hoods</b>					
Tüllengehäuse, Abgang oben <i>Hood, top entry</i> 		13,5	C146 10G006 600 1		
		16	C146 10G006 601 1		
		16		C146 10G006 656 8	
		21		C146 10G006 606 8	
		29		C146 10G006 607 8	
Tüllengehäuse, Abgang Seite <i>Hood, side entry</i> 		13,5	C146 10G006 500 1		
		16	C146 10G006 501 1		
		16		C146 10G006 556 8	
		21		C146 10G006 506 8	
		29		C146 10G006 507 8	
<b>Gehäuseunterteile / Housings</b>					
Kupplungsgehäuse, <i>Hood, coupling application</i> 		h 52	13,5	C146 10G006 804 1	
		52	16	C146 10G006 805 1	
		70	21		C146 10G006 804 8
		70	29		C146 10G006 805 8
Anbaugehäuse <sup>1)</sup> <i>Housing, bulkhead mounting <sup>1)</sup></i> 		—	C146 10F006 000 1		
Anbaugehäuse mit Klappdeckel <sup>1)</sup> <i>Housing, bulkhead mounting with spring cover <sup>1)</sup></i> 		—	C146 10F006 003 1		

<sup>1)</sup> incl. Flachdichtung / incl. gasket

housings for 1 locking-lever-system  
 in accordance with  
 DIN EN 175 301 - 801 (DIN 43 652)

Metrisches Gewinde  
 Metric thread

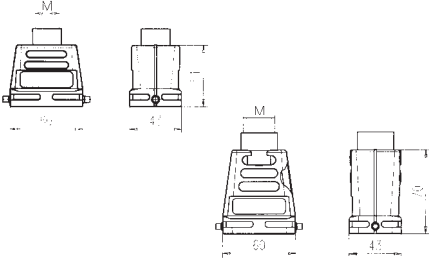
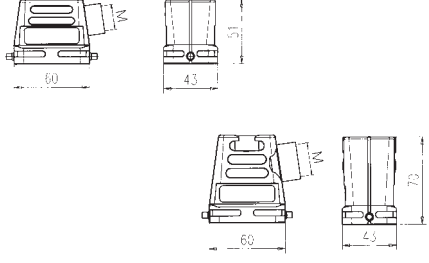
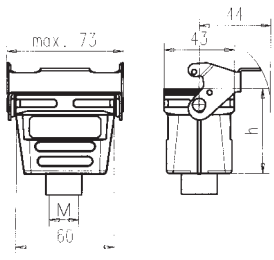
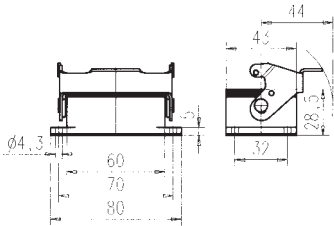





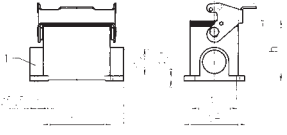

Maßzeichnung Drawing	M	Bestell Nr. / Part No.		Bestell Nr. / Part No.		
		Niedrige Bauform/ Low profile	Hohe Bauform/ High profile	Niedrige Bauform/ Low profile	Hohe Bauform/ High profile	
		mit Stützen / with stud		ohne Stützen / without stud		
	16	C146 10R006 656 1		C146 21R006 656 1		
	20	C146 10R006 606 1		C146 21R006 606 1		
	25	C146 10R006 607 1		C146 21R006 607 1		
	25		C146 10R006 656 8		C146 21R006 656 8	
	32		C146 10R006 606 8		C146 21R006 606 8	
	20	C146 10R006 506 1		C146 21R006 506 1		
	25	C146 10R006 507 1		C146 21R006 507 1		
	25		C146 10R006 556 8		C146 21R006 556 8	
	32		C146 10R006 506 8		C146 21R006 506 8	
	h					
	52	20	C146 10R006 804 1		C146 21R006 804 1	
	52	25	C146 10R006 805 1		C146 21R006 805 1	
	70	25		C146 10R006 854 8		C146 21R006 854 8
	70	32		C146 10R006 804 8		C146 21R006 804 8
			C146 10F006 000 1			
			C146 10F006 003 1			

C 146 E 6 pol.  
 C 146 M 2 Module  
 C 146 DD 24 pol.  
 C 146 EE 10 pol.

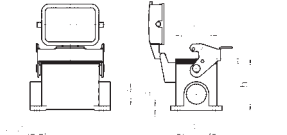
Gehäuse für Längsbügelverriegelung  
 in Anlehnung an  
 DIN EN 175 301 - 801 (DIN 43 652)

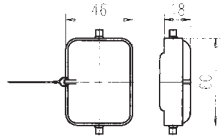
Gehäuse  
 Housings

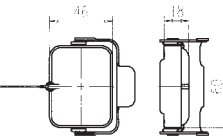
PG-Gewinde  
 PG-thread

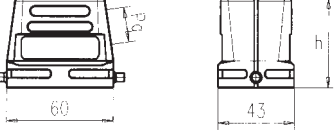
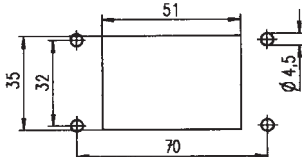
Bezeichnung - Abbildung Description - Figure	Maßzeichnung Drawing	PG	Bestell Nr. / Part No.		
			Niedrige Bauform/ Low profile	Hohe Bauform/ High profile	
<b>Gehäuseunterteil / Housings</b>		<b>h</b>	<b>1 Kabelabgang / Single side entry</b>		
Sockelgehäuse Housing 	 1 Geschlossen bei einem Kabelausgang 1 closed if single entry	54	16	C146 10F006 500 1	C146 10F006 803 2 C146 10F006 503 2 (*) C146 10F006 802 2 C146 10F006 502 2 (*)
		54/74	16/21	C146 10F006 502 1	
		74	21	(*)	
		74	29		
			<b>2 Kabelabgänge / Double side entry</b>		
		54	16	C146 10F006 600 1	
		74	21		C146 10F006 603 2
		74	29		C146 10F006 602 2
<b>Sockelgehäuse mit Klappdeckel Housing with spring cover</b>			<b>1 Kabelabgang / Single side entry</b>		
	 1 Geschlossen bei einem Kabelausgang 1 closed if single entry	54	16	C146 10F006 806 1	C146 10F006 807 2 C146 10F006 507 2 (*) C146 10F006 806 2 C146 10F006 506 2 (*)
		54/74	16/21	C146 10F006 506 1 (*)	
		74	21		
		74	29		
			<b>2 Kabelabgänge / Double side entry</b>		
		54	16	C146 10F006 606 1	
		74	21		C146 10F006 607 2
		74	29		C146 10F006 606 2
<b>Schutzkappen / Protective cover</b>					
Schutzkappe für Gehäuseunterteile Cover for housings 		-	C146 10Z006 100 1		
Schutzkappe für Gehäuseoberteile Cover for housings 		-	C146 10Z006 200 1		
<b>Sondergehäuse / Special housings</b>					
Tüllengehäuse ohne Stutzen Hood, without stud 		16	C146 21G006 501 1		
		21	C146 21G006 506 8		
<b>Montageausschnitt / Panel cut out</b>					
					

Verschraubung für Tüllen- und Sockelgehäuse siehe Seite 170-173 / gland bushings for hoods and housing see page 170-173  
 Bei Sockelgehäusen Abgang rechts dargestellt / housings are shown with right outlet

housings for 1 locking-lever-system  
 in accordance with  
 DIN EN 175 301 - 801 (DIN 43 652)

Metrisches Gewinde  
 Metric thread

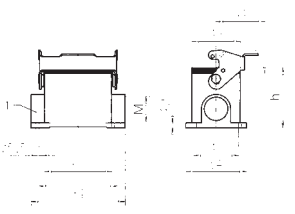
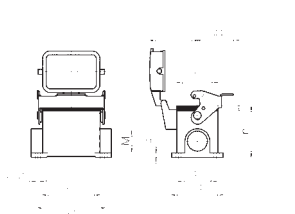
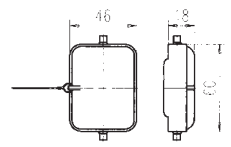
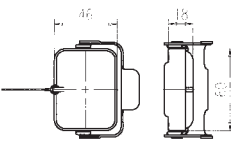
Maßzeichnung Drawing	M	Bestell Nr. / Part No.		Bestell Nr. / Part No.		
		Niedrige Bauform/ Low profile	Hohe Bauform/ High profile	Niedrige Bauform/ Low profile	Hohe Bauform/ High profile	
		<b>1 Kabelabgang</b>		<b>2 Kabelabgänge</b>		
 <p>1 Geschlossen bei einem Kabelausgang 1 closed if single entry</p>	h					
	54	20	C146 10N006 803 1		C146 10N006 603 1	
	54	20	C146 10N006 503 1 <sup>(l)</sup>		C146 10N006 703 1 <sup>(r+u)</sup>	
	54/74	25	C146 10N006 802 1	C146 10N006 803 2	C146 10N006 602 1	C146 10N006 603 2
	54/74	25	C146 10N006 502 1 <sup>(l)</sup>	C146 10N006 503 2 <sup>(l)</sup>	C146 10N006 702 1 <sup>(r+u)</sup>	
	74	32		C146 10N006 802 2		C146 10N006 602 2
74	32		C146 10N006 502 2 <sup>(l)</sup>			
 <p>1 Geschlossen bei einem Kabelausgang 1 closed if single entry</p>	54	20	C146 10N006 807 1		C146 10N006 607 1	
	54	20	C146 10N006 507 1 <sup>(l)</sup>		C146 10N006 709 1 <sup>(r+u)</sup>	
	54/74	25	C146 10N006 806 1	C146 10N006 807 2	C146 10N006 606 1	C146 10N006 607 2
	54/74	25	C146 10N006 506 1 <sup>(l)</sup>	C146 10N006 507 2 <sup>(l)</sup>	C146 10N006 708 1 <sup>(r+u)</sup>	
	74	32		C146 10N006 806 2		C146 10N006 606 2
	74	32		C146 10N006 506 2 <sup>(l)</sup>		
	-		C146 10Z006 100 1			
		-		C146 10Z006 200 1		

<sup>(r+u)</sup> rechts und unten / right and bottom  
<sup>(l)</sup> links / left







**C 146 E 10 pol.**  
**C 146 M 3 Module**  
**C 146 DD 42 pol.**  
**C 146 HvE 3 pol.**  
**C 146 EE 18 pol.**

**Gehäuse**  
**Housings**

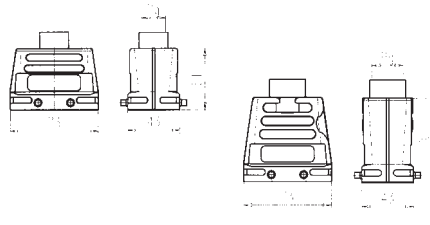
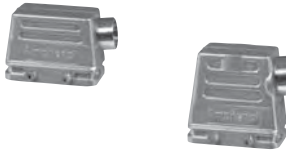
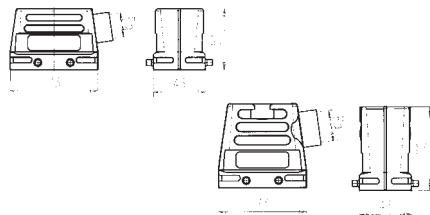
**Gehäuse für Querbügelverriegelung**  
**in Anlehnung an**  
**DIN EN 175 301 - 801 (DIN 43 652)**

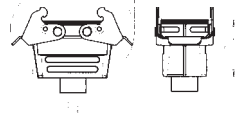
- sichere 4-Punkt Verriegelung
- bevorzugt bei seitlicher Anreihung
- fliegende Verbindung möglich

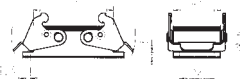
**PG-Gewinde**  
**PG-thread**

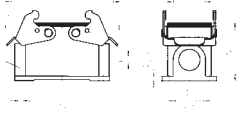
Bezeichnung - Abbildung <i>Description - Figure</i>	Maßzeichnung <i>Drawing</i>	PG	Bestell Nr. / Part No.		
			Niedrige Bauform / Low profile	Hohe Bauform / High profile	
<b>Gehäuseoberteile / Hoods</b>					
Tüllengehäuse, Abgang oben <i>Hood, top entry</i> 		16	C146 10G010 600 1		
		21	C146 10G010 601 1		
		16		C146 10G010 650 8	
		21		C146 10G010 600 8	
		29		C146 10G010 601 8	
Tüllengehäuse, Abgang Seite <i>Hood, side entry</i> 		16	C146 10G010 500 1		
		21	C146 10G010 501 1		
		16		C146 10G010 550 8	
		21		C146 10G010 500 8	
		29		C146 10G010 501 8	
<b>Gehäuseunterteile / Housings</b>					
Kupplungsgehäuse <i>Hood, coupling application</i> 		h			
		51	16	C146 10G010 802 1	
		51/70	21	C146 10G010 803 1	C146 10G010 802 8
		29		C146 10G010 803 8	
Anbaugehäuse <sup>1)</sup> <i>Housing, bulkhead mounting <sup>1)</sup></i> 				C146 10F010 000 1	
Winkelanbaugehäuse <sup>1)</sup> <i>Right-angled housing <sup>1)</sup></i> 				C146 10F010 090 1	
Sockelgehäuse <i>Housing</i> 		h	1 Kabelabgang / single side entry		
		57	16	C146 10F010 500 1	
		74	21		C146 10F010 501 2
		74	29		C146 10F010 500 2
				2 Kabelabgänge / Double side entry	
		57	16	C146 10F010 600 1	
74	21		C146 10F010 601 2		
74	29		C146 10F010 600 2		

**Montageausschnitt für Anbaugehäuse / Panel cut out for housing bulkhead mounting**

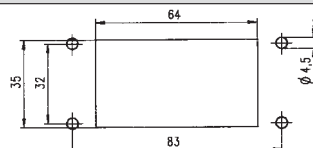

Verschraubung für Tüllen- und Sockelgehäuse siehe Seite 170-173 / gland bushings for hoods and housing see page 170-173

<sup>1)</sup> incl. Flachdichtung / incl. gasket



**housings for 2 locking-lever-system  
 according to DIN EN 175 301 - 801  
 (DIN 43 652)**

- secured 4 point locking
- preferred for side by side mounting
- cable to cable possible

**Metrisches Gewinde  
 Metric thread**

Maßzeichnung Drawing	M	Bestell Nr. / Part No.		Bestell Nr. / Part No.		
		Niedrige Bauform/ Low profile	Hohe Bauform/ High profile	Niedrige Bauform/ Low profile	Hohe Bauform/ High profile	
			mit Stützen / with stud		ohne Stützen / without stud	
	20	C146 10R010 650 1		C146 21R010 650 1		
	25	C146 10R010 600 1		C146 21R010 600 1		
	25		C146 10R010 650 8		C146 21R010 650 8	
	32		C146 10R010 600 8		C146 21R010 600 8	
	40		C146 10R010 601 8		C146 21R010 601 8	
	20	C146 10R010 550 1		C146 21R010 550 1		
	25	C146 10R010 500 1		C146 21R010 500 1		
	25		C146 10R010 550 8		C146 21R010 550 8	
	32		C146 10R010 500 8		C146 21R010 500 8	
	h					
	51	20	C146 10R010 852 1		C146 21R010 852 1	
	51/70	25	C146 10R010 802 1	C146 10R010 852 8	C146 21R010 802 1	C146 21R010 852 8
	51/70	32	C146 10R010 803 1	C146 10R010 802 8	C146 21R010 803 1	C146 21R010 802 8
	70	40		C146 10R010 803 8		C146 21R010 803 8
		—	C146 10F010 000 1			
			C146 10F010 090 1			
<p>1.) Verschlusschraube bei einem Kabelausgang 1.) Screwed sealing plug if single entry</p>	h		1 Kabelabgang / single side entry		2 Kabelabgänge / Double side entry	
	57	20	C146 10N010 501 1		C146 10N010 601 1	
	57	20			C146 10N010 701 1 <sup>(r+u)</sup>	
	57/74	25	C146 10N010 500 1	C146 10N010 501 2	C146 10N010 600 1	C146 10N010 601 2
	57	25			C146 10N010 700 1 <sup>(r+u)</sup>	
74	32		C146 10N010 500 2		C146 10N010 600 2	

<sup>(r+u)</sup> rechts und unten / right and bottom









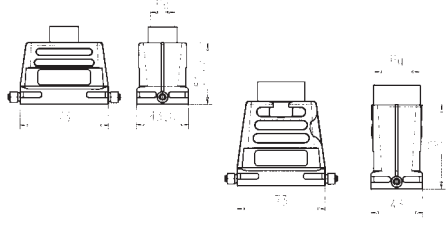
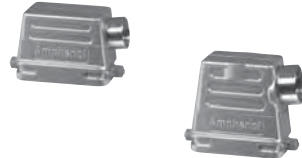
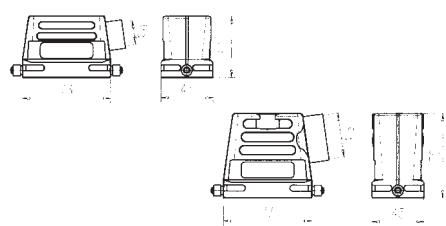

C 146 E 10 pol.  
 C 146 M 3 Module  
 C 146 DD 42 pol.  
 C 146 HvE 3 pol.  
 C 146 EE 18 pol.

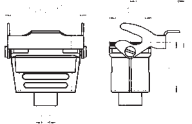
Gehäuse  
 Housings

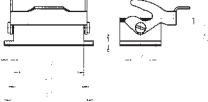
Gehäuse für Längsbügelverriegelung  
 in Anlehnung an  
 DIN EN 175 301 - 801 (DIN 43 652)

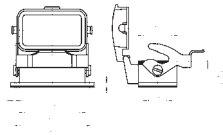
- leichtes Bedienen auch bei seitlichem Kabelabgang
- Schutzkappe am Gehäuseunterteil verriegelbar
- fliegende Verbindung möglich

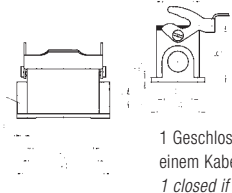
PG-Gewinde  
 PG-thread

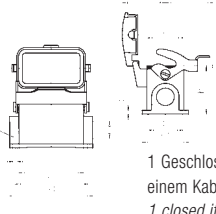
Bezeichnung - Abbildung Description - Figure	Maßzeichnung Drawing	PG	Bestell Nr. / Part No.		
			Niedrige Bauform / Low profile	Hohe Bauform / High profile	
<b>Gehäuseoberteile / Hoods</b>					
Tüllengehäuse, Abgang oben Hood, top entry 		16	C146 10G010 606 1		
		21	C146 10G010 607 1		
		21		C146 10G010 606 8	
		29		C146 10G010 607 8	
Tüllengehäuse, Abgang Seite Hood, side entry 		16	C146 10G010 506 1		
		21	C146 10G010 507 1		
		21		C146 10G010 506 8	
		29		C146 10G010 507 8	
<b>Gehäuseunterteile / Housings</b>					
Kupplungsgehäuse Hood, coupling application 		h 51	16	C146 10G010 804 1	
		51/70	21	C146 10G010 805 1	C146 10G010 804 8
		70	29		C146 10G010 805 8
Anbaugehäuse <sup>1)</sup> Housing, bulkhead mounting <sup>1)</sup> 				C146 10F010 001 1	
Anbaugehäuse mit Deckel <sup>1)</sup> Housing with spring cover <sup>1)</sup> 				C146 10F010 003 1	
Sockelgehäuse Housing 		h 57	16 16/21 21 29 29	1 Kabelabgang / Single side entry	
		57/74		C146 10F010 802 1	C146 10F010 803 2
		74		C146 10F010 502 1 <sup>(1)</sup>	C146 10F010 503 2 <sup>(1)</sup>
		74			C146 10F010 802 2
				2 Kabelabgänge / Double side entry	
		57	16	C146 10F010 602 1	C146 10F010 603 2
		74	21		C146 10F010 602 2
		74	29		C146 10F010 602 2
Sockelgehäuse mit Deckel Housing with spring cover 		h 57	16 16/21 21 29 29	1 Kabelabgang / Single side entry	
		57/74		C146 10F010 806 1	C146 10F010 807 2
		74		C146 10F010 506 1 <sup>(1)</sup>	C146 10F010 507 2 <sup>(1)</sup>
		74			C146 10F010 806 2
		74			C146 10F010 506 2 <sup>(1)</sup>
		57	16	C146 10F010 606 1	C146 10F010 607 2
		74	21		C146 10F010 606 2
		74	29		C146 10F010 606 2

<sup>1)</sup> incl. Flachdichtung / incl. flat sealing

<sup>(1)</sup> links / left

Bei Sockelgehäusen Abgang rechts dargestellt / housings are shown with right outlet

**housings for 1 locking-lever-system  
 in accordance with  
 DIN EN 175 301 - 801 (DIN 43 652)**

- also easy to use for side entry
- cover for housings lockable
- cable to cable possible

**Metrisches Gewinde  
 Metric thread**

Maßzeichnung Drawing	M	Bestell Nr. / Part No.		Bestell Nr. / Part No.		
		Niedrige Bauform/ Low profile	Hohe Bauform/ High profile	Niedrige Bauform/ Low profile	Hohe Bauform/ High profile	
		mit Stützen / with stud		ohne Stützen / without stud		
	20	C146 10R010 656 1		C146 21R010 656 1		
	25	C146 10R010 606 1		C146 21R010 606 1		
	32	C146 10R010 607 1		C146 21R010 607 1		
	25		C146 10R010 656 8		C146 21R010 656 8	
	32		C146 10R010 606 8		C146 21R010 606 8	
40		C146 10R010 607 8		C146 21R010 607 8		
	20	C146 10R010 556 1		C146 21R010 556 1		
	25	C146 10R010 506 1		C146 21R010 506 1		
	25		C146 10R010 556 8		C146 21R010 556 8	
	32		C146 10R010 506 8		C146 21R010 506 8	
	h					
	51	20	C146 10R010 854 1		C146 21R010 854 1	
	51/70	25	C146 10R010 804 1	C146 10R010 854 8	C146 21R010 804 1	C146 21R010 854 8
	51/70	32	C146 10R010 805 1	C146 10R010 804 8	C146 21R010 805 1	C146 21R010 804 8
70	40		C146 10R010 805 8		C146 21R010 805 8	
		-	C146 10F010 001 1			
			-	C146 10F010 003 1		
<p>1 Geschlossen bei einem Kabelausgang 1 closed if single entry</p>		h		1 Kabelabgang / Single side entry		2 Kabelabgänge / Double side entry
	57	20	C146 10N010 803 1		C146 10N010 603 1	
	57	20	C146 10N010 503 1 (*)		C146 10N010 703 1 (r+u)	
	57/74	25	C146 10N010 802 1	C146 10N010 803 2	C146 10N010 602 1	C146 10N010 603 2
	57/74	25	C146 10N010 502 1 (*)	C146 10N010 503 2 (*)	C146 10N010 702 1 (r+u)	
	74	32		C146 10N010 802 2		C146 10N010 602 2
74	32		C146 10N010 502 2 (*)			
<p>1 Geschlossen bei einem Kabelausgang 1 closed if single entry</p>	h		1 Kabelabgang / Single side entry		2 Kabelabgänge / Double side entry	
	57	20	C146 10N010 807 1		C146 10N010 607 1	
	57	20	C146 10N010 507 1 (*)		C146 10N010 708 1 (r+u)	
	57/74	25	C146 10N010 806 1	C146 10N010 807 2	C146 10N010 606 1	C146 10N010 607 2
	57/74	25	C146 10N010 506 1 (*)	C146 10N010 507 2 (*)	C146 10N010 709 1 (r+u)	
	74	32		C146 10N010 806 2		C146 10N010 606 2
74	32		C146 10N010 506 2 (*)			

(\*) links / left

(r+u) rechts und unten / right and bottom







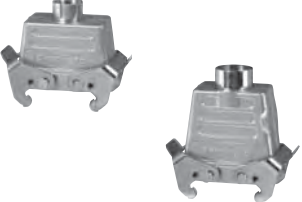
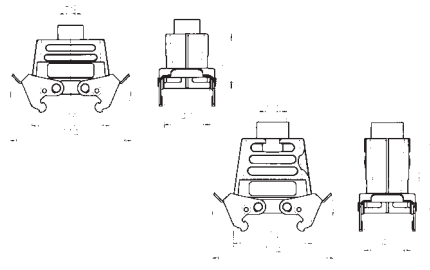

**C 146 E** 10 pol.  
**C 146 M** 3 Module  
**C 146 DD** 42 pol.  
**C 146 HvE** 3 pol.  
**C 146 EE** 18 pol.

**Gehäuse**  
**Housings**

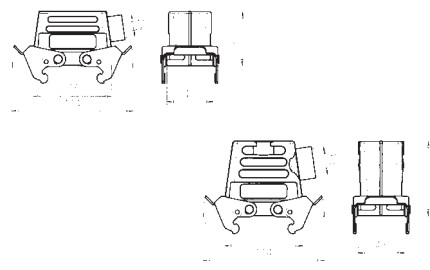
**Tüllengehäuse mit Querbügel**  
**in Anlehnung an**  
**DIN EN 175 301 - 801 (DIN 43 653)**

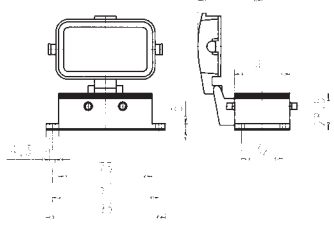
- sichere 4-Punkt Verriegelung
- Gehäuseunterteil mit Schutzdeckel
- keine Bügel am Gehäuseunterteil

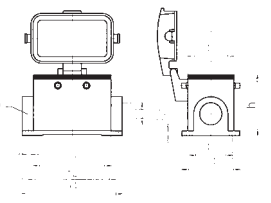
**PG-Gewinde**  
**PG-thread**

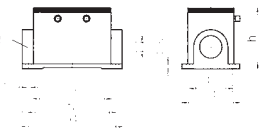
Bezeichnung - Abbildung <i>Description - Figure</i>	Maßzeichnung <i>Drawing</i>	PG	Bestell Nr. / Part No.			
			Niedrige Bauform / <i>Low profile</i>	Hohe Bauform / <i>High profile</i>		
<b>Gehäuseoberteile / Hoods</b>						
Tüllengehäuse, Abgang oben <i>Hood, top entry</i> 		16	C146 10G010 602 1			
		21	C146 10G010 603 1			
		21		C146 10G010 602 8		
		29		C146 10G010 603 8		
Tüllengehäuse, Abgang Seite <i>Hood, side entry</i> 		16	C146 10G010 502 1			
		21	C146 10G010 503 1			
		21		C146 10G010 502 8		
		29		C146 10G010 503 8		
<b>Gehäuseunterteile / Housings</b>						
Anbaugehäuse mit Deckel <sup>1)</sup> <i>Housing, with spring cover <sup>1)</sup></i> 		-	C146 10F010 002 1			
Sockelgehäuse, mit Deckel <i>Housing, with spring cover</i> 		h 57 16 57/74 16/21 74 21 74 29 74 29	1 Kabelabgang / <i>Single side entry</i>			
			C146 10F010 804 1	C146 10F010 805 2		
			C146 10F010 504 1 <sup>(1)</sup>	C146 10F010 505 2 <sup>(1)</sup>		
				C146 10F010 804 2		
				C146 10F010 504 2 <sup>(1)</sup>		
			2 Kabelabgänge / <i>Double side entry</i>		C146 10F010 604 1	
1 Geschlossen bei einem Kabelausgang <i>1 closed if single entry</i>			C146 10F010 605 2			
			C146 10F010 604 2			
Sockelgehäuse <i>Housing</i> 		h 74 21 74 29 74 21 74 29	1 Kabelabgang / <i>Single side entry</i>			
				C146 10F010 509 2		
				C146 10F010 508 2		
			2 Kabelabgänge / <i>Double side entry</i>			C146 10F010 609 2
			1 Geschlossen bei einem Kabelausgang <i>1 closed if single entry</i>			C146 10F010 608 2

<sup>1)</sup> incl. Flachdichtung / *incl. gasket*

Bei Sockelgehäusen Abgang rechts dargestellt /  *housings are shown with right outlet*

**hoods with 2 locking-levers  
in accordance with  
DIN EN 175 301 - 801 (DIN 43 653)**

- **secured 4 point locking**
- **housing with cover**
- **no locking levers at the housings**

**Metrisches Gewinde  
Metric thread**

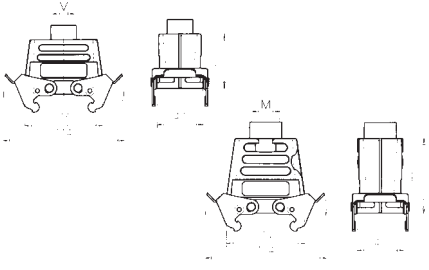
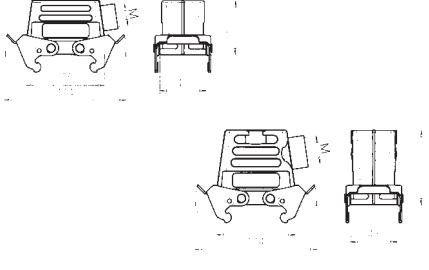
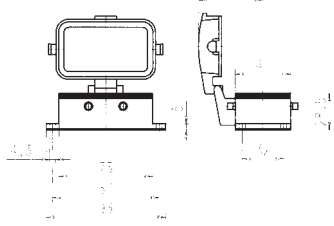
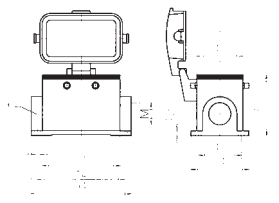
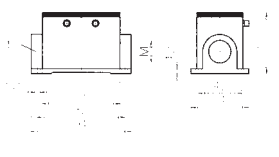
Maßzeichnung Drawing	M	Bestell Nr. / Part No.		Bestell Nr. / Part No.		
		Niedrige Bauform/ Low profile	Hohe Bauform/ High profile	Niedrige Bauform/ Low profile	Hohe Bauform/ High profile	
		mit Stützen / with stud		ohne Stützen / without stud		
	20	C146 10R010 652 1		C146 21R010 652 1		
	25	C146 10R010 602 1		C146 21R010 602 1		
	25		C146 10R010 652 8		C146 21R010 652 8	
	32		C146 10R010 602 8		C146 21R010 602 8	
	40		C146 10R010 603 8		C146 21R010 603 8	
	20	C146 10R010 552 1		C146 21R010 552 1		
	25	C146 10R010 502 1		C146 21R010 502 1		
	25		C146 10R010 552 8		C146 21R010 552 8	
	32		C146 10R010 502 8		C146 21R010 502 8	
	—	C146 10F010 002 1				
 <p>1 Geschlossen bei einem Kabelausgang 1 closed if single entry</p>	h	1 Kabelabgang / Single side entry		2 Kabelabgänge / Double side entry		
	57	20	C146 10N010 805 1		C146 10N010 605 1	
	57	20	C146 10N010 505 1 <sup>(*)</sup>		C146 10N010 809 1 <sup>(r+u)</sup>	
	57/74	25	C146 10N010 804 1	C146 10N010 805 2	C146 10N010 604 1	C146 10N010 605 2
	57/74	25	C146 10N010 504 1 <sup>(*)</sup>	C146 10N010 505 2 <sup>(*)</sup>	C146 10N010 808 1 <sup>(r+u)</sup>	
	74	32		C146 10N010 804 2		C146 10N010 604 2
74	32		C146 10N010 504 2 <sup>(*)</sup>			
 <p>1 Geschlossen bei einem Kabelausgang 1 closed if single entry</p>	h	1 Kabelabgang / Single side entry		2 Kabelabgänge / Double side entry		
	57	20	C146 10N010 509 1		C146 10N010 609 1	
	57/74	25	C146 10N010 508 1	C146 10N010 509 2	C146 10N010 608 1	C146 10N010 609 2
74	32		C146 10N010 508 2		C146 10N010 608 2	

<sup>(\*)</sup> links / left

<sup>(r+u)</sup> rechts und unten / right and bottom





C 146 E 10 pol.  
 C 146 M 3 Module  
 C 146 DD 42 pol.  
 C 146 HvE 3 pol.  
 C 146 EE 18 pol.

Gehäuse, Schutzkappen  
 Housings, covers

Sondergehäuse für Querbügelverriegelung,  
 in Anlehnung an  
 DIN EN 175 301 - 801 (DIN 43 653)

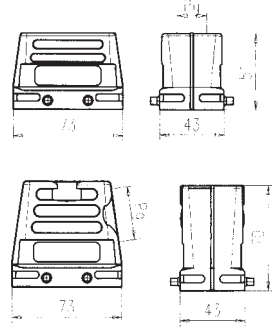
PG-Gewinde  
 PG-thread

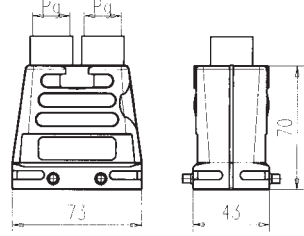
special housings for 2 locking-system,  
 in accordance with  
 DIN EN 175 301 - 801 (DIN 43 653)

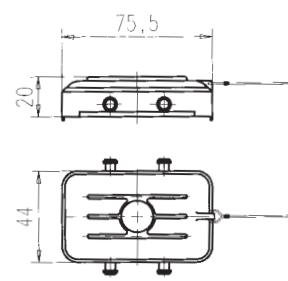
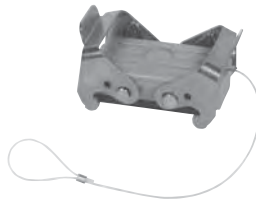
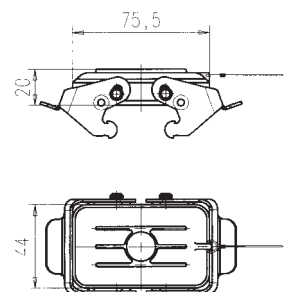
Bezeichnung - Abbildung Description - Figure	Maßzeichnung Drawing	PG	Kabelabgang cable outlet	Bestell Nr. / Part No.	
				Niedrige Bauform / Low profile	Hohe Bauform / High profile
<b>Gehäuseoberteile / Hoods</b>					
Tüllengehäuse ohne Stutzen Hood without stud  		16	Oben / top  Seite / side	C146 21G010 600 1  C146 21G010 500 1	
		21	Oben / top  Seite / side		C146 21G010 600 8  C146 21G010 500 8
Tüllengehäuse, 2 x Abgang Oben Hood, 2 top entry  		16			C146 10G010 902 8
<b>Schutzkappen / Protective cover</b>					
Schutzkappe für Gehäuseunterteile Cover for housings  		-			C146 10Z010 100 1
Schutzkappe für Gehäuseoberteile Cover for hoods  		-			C146 10Z010 200 1

Verschraubung für Tüllen- und Sockelgehäuse siehe Seite 170-173 / gland bushings for hoods and housing see page 170-173







C 146 E 10 pol.  
 C 146 M 3 Module  
 C 146 DD 42 pol.  
 C 146 HvE 3 pol.  
 C 146 EE 18 pol.

Gehäuse, Schutzkappen  
 Housings, covers

Sondergehäuse für Querbügelverriegelung,  
 in Anlehnung an  
 DIN EN 175 301 - 801 (DIN 43 653)

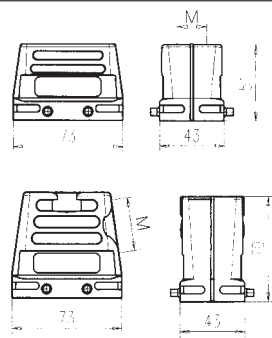
Metrisches Gewinde  
 Metric thread

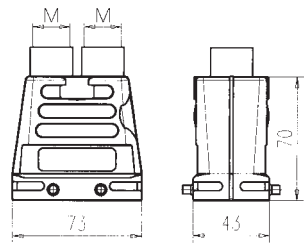
special housings for 2 locking-system,  
 in accordance with  
 DIN EN 175 301 - 801 (DIN 43 653)

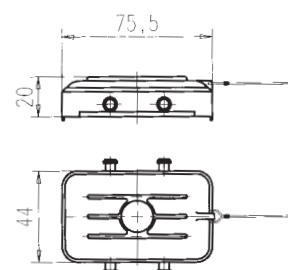
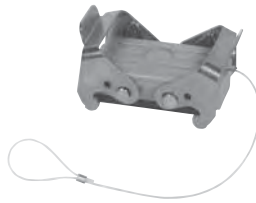
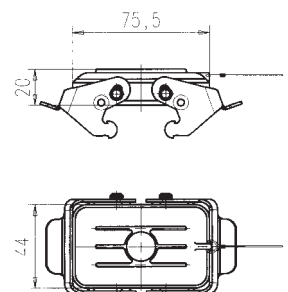
Bezeichnung - Abbildung Description - Figure	Maßzeichnung Drawing	M	Kabelabgang cable outlet	Bestell Nr. / Part No.	
				Niedrige Bauform / Low profile	Hohe Bauform / High profile
<b>Gehäuseoberteile / Hoods</b>					
Tüllengehäuse ohne Stutzen Hood without stud  		20	Oben / top	C146 21R010 650 1	
		20	Seite / side	C146 21R010 550 1	
		25	Oben / top	C146 21R010 600 1	
		25	Seite / side	C146 21R010 500 1	
		25	Oben / top		C146 21R010 650 8
		25	Seite / side		C146 21R010 550 8
		32	Oben / top		C146 21R010 600 8
32	Seite / side		C146 21R010 500 8		
40	Oben / top		C146 21R010 601 8		
Tüllengehäuse, 2 x Abgang Oben Hood, 2 top entry  		25			C146 10R010 902 8
<b>Schutzkappen / Protective cover</b>					
Schutzkappe für Gehäuseunterteile Cover for housings  		-		C146 10Z010 100 1	
Schutzkappe für Gehäuseoberteile Cover for hoods  		-		C146 10Z010 200 1	







Verschraubung für Tüllen- und Sockelgehäuse siehe Seite 170-173 / gland bushings for hoods and housing see page 170-173

**C 146 E** 16 pol.  
**C 146 M** 5 Module  
**C 146 D** 40 pol.  
**C 146 DD** 72 pol.  
**C 146 HSE** 6 pol.  
**C 146 HvE** 6 pol.  
**C 146 EE** 32 pol.  
 Gehäuse / Housings

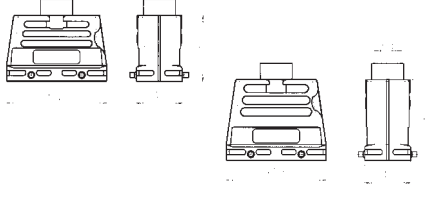
Gehäuse für Querbügelverriegelung nach  
 DIN EN 175 301 - 801 (DIN 43 652)

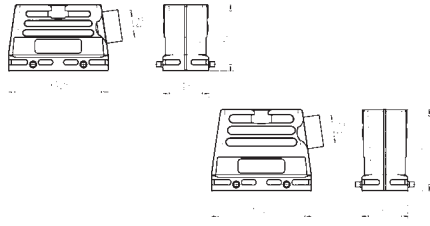
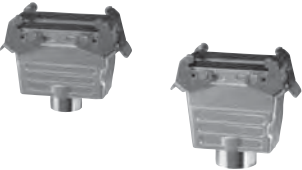
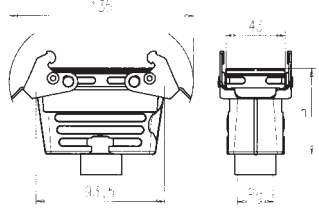
- sichere 4-Punkt Verriegelung
- bevorzugt bei seitlicher Anreihung
- fliegende Verbindung möglich

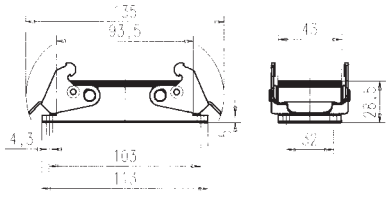
**PG-Gewinde**  
**PG-thread**

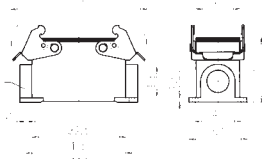
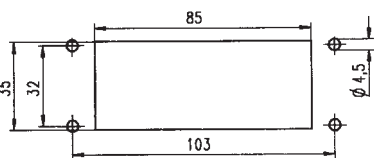
Bezeichnung - Abbildung <i>Description - Figure</i>	Maßzeichnung <i>Drawing</i>	PG	Bestell Nr. / Part No.		
			Niedrige Bauform / Low profile	Hohe Bauform / High profile	
<b>Gehäuseoberteile / Hoods</b>					
Tüllengehäuse, Abgang oben <i>Hood, top entry</i> 		21	C146 10G016 600 1		
		29	C146 10G016 601 1		
		21		C146 10G016 600 8	
		29		C146 10G016 601 8	
Tüllengehäuse, Abgang Seite <i>Hood, side entry</i> 		21	C146 10G016 500 1		
		29	C146 10G016 501 1		
		21		C146 10G016 500 8	
		29		C146 10G016 501 8	
<b>Gehäuseunterteile / Housings</b>					
Kupplungsgehäuse <i>Hood, coupling application</i> 		h			
		62	21	C146 10G016 802 1	
		62	29	C146 10G016 803 1	
		76	21		C146 10G016 802 8
76	29		C146 10G016 803 8		
Anbaugehäuse <sup>1)</sup> <i>Housing, bulkhead mounting <sup>1)</sup></i> 		-	C146 10F016 000 1		
Sockelgehäuse <i>Housing</i> 	 <p>1 Geschlossen bei einem Kabelausgang 1 closed if single entry</p>	h			
		64/77	21	1 Kabelabgang / Single side entry	
		77	29	C146 10F016 500 1	C146 10F040 501 2 C146 10F040 500 2
		64/77	21	2 Kabelabgänge / Double side entry	
		77	29	C146 10F016 600 1	C146 10F040 601 2 C146 10F040 600 2
		<b>Montageausschnitt für Anbaugehäuse / Panel cut out for housing bulkhead mounting</b>			
					

<sup>(1)</sup> links / left

**housings for 2 locking-lever-system according to  
 DIN EN 175 301 - 801 (DIN 43 652)**

- **secured 4 point locking**
- **preferred for side by side mounting**
- **cable to cable possible**

**Metrisches Gewinde  
Metric thread**

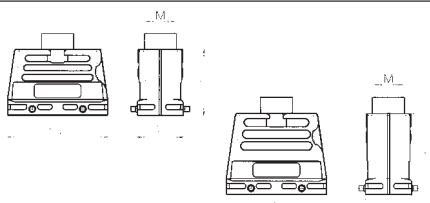
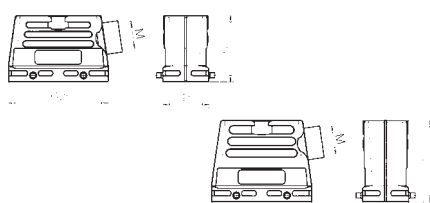
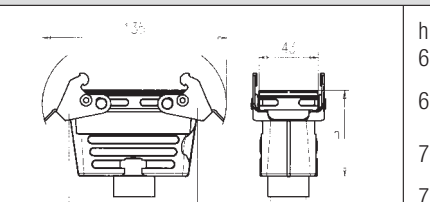
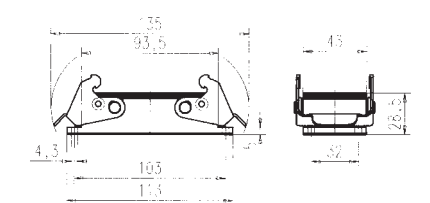
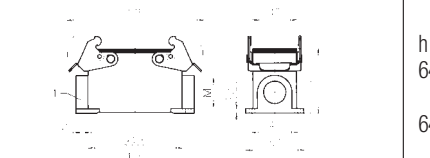
Maßzeichnung <i>Drawing</i>	M	Bestell Nr. / <i>Part No.</i>		Bestell Nr. / <i>Part No.</i>		
		Niedrige Bauform/ <i>Low profile</i>	Hohe Bauform/ <i>High profile</i>	Niedrige Bauform/ <i>Low profile</i>	Hohe Bauform/ <i>High profile</i>	
		mit Stützen / <i>with stud</i>		ohne Stützen / <i>without stud</i>		
	25	C146 10R016 650 1		C146 21R016 650 1		
	32	C146 10R016 600 1		C146 21R016 600 1		
	25		C146 10R016 650 8		C146 21R016 650 8	
	32		C146 10R016 600 8		C146 21R016 600 8	
	25	C146 10R016 550 1		C146 21R016 550 1		
	32	C146 10R016 500 1		C146 21R016 500 1		
	25		C146 10R016 550 8		C146 21R016 550 8	
	32		C146 10R016 500 8		C146 21R016 500 8	
	25	C146 10R016 852 1		C146 21R016 852 1		
	32	C146 10R016 802 1		C146 21R016 802 1		
	25		C146 10R016 852 8		C146 21R016 852 8	
	32		C146 10R016 802 8		C146 21R016 802 8	
	40		C146 10F016 000 1			
 <p>1 Geschlossen bei einem Kabelausgang <i>1 closed if single entry</i></p>	25	1 Kabelabgang / <i>Single side entry</i>		2 Kabelabgänge / <i>Double side entry</i>		
	25	C146 10N016 500 1	C146 10N016 501 2	C146 10N016 600 1	C146 10N016 601 2	
	32		C146 10N016 500 2	C146 10N016 700 1 <sup>(r+u)</sup>	C146 10N016 701 2 <sup>(r+u)</sup>	
	32			C146 10N016 600 2	C146 10N016 700 2 <sup>(r+u)</sup>	

<sup>(r+u)</sup> rechts und unten / *right and bottom*









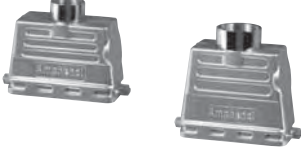
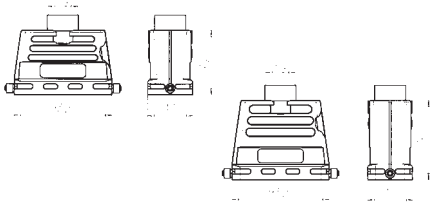
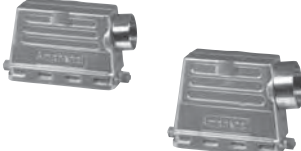
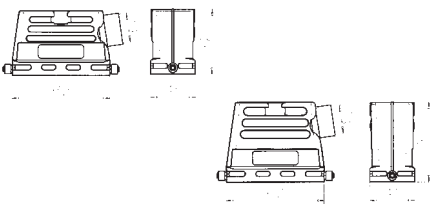

Bei Sockelgehäusen Abgang rechts dargestellt /  *housings are shown with right outlet*

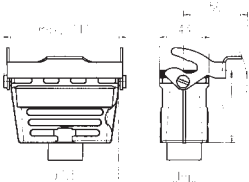
**C 146 E** 16 pol.  
**C 146 M** 5 Module  
**C 146 D** 40 pol.  
**C 146 DD** 72 pol.  
**C 146 HSE** 6 pol.  
**C 146 HvE** 6 pol.  
**C 146 EE** 32 pol.  
 Gehäuse / Housings

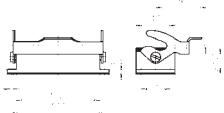
Gehäuse für Längsbügelverriegelung nach  
 DIN EN 175 301 - 801 (DIN 43 652)

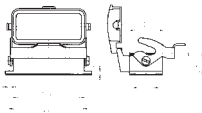
- leichtes Bedienen auch bei seitlichem Kabelabgang
- Schutzkappe am Gehäuseunterteil verriegelbar
- fliegende Verbindung möglich

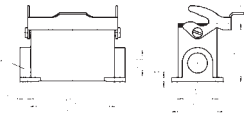
**PG-Gewinde**  
**PG-thread**

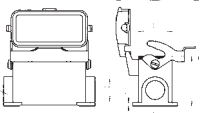
Bezeichnung - Abbildung <i>Description - Figure</i>	Maßzeichnung <i>Drawing</i>	PG	Bestell Nr. / Part No.		
			Niedrige Bauform / Low profile	Hohe Bauform / High profile	
<b>Gehäuseoberteile / Hoods</b>					
Tüllengehäuse, Abgang oben <i>Hood, top entry</i> 		21	C146 10G016 606 1		
		29	C146 10G016 607 1		
		21		C146 10G016 606 8	
		29		C146 10G016 607 8	
Tüllengehäuse, Abgang Seite <i>Hood, side entry</i> 		21	C146 10G016 506 1		
		29	C146 10G016 507 1		
		21		C146 10G016 506 8	
		29		C146 10G016 507 8	
<b>Gehäuseunterteile / Housings</b>					
Kupplungsgehäuse <i>Hood, coupling application</i> 		h			
		62	21	C146 10G016 804 1	
		62	29	C146 10G016 805 1	
		76	21		C146 10G016 804 8
		76	29		C146 10G016 805 8
Anbaugehäuse <sup>1)</sup> <i>Housing, bulkhead mounting <sup>1)</sup></i> 		-	C146 10F016 001 1		
Anbaugehäuse mit Deckel <sup>1)</sup> <i>Housing with spring cover <sup>1)</sup></i> 		-	C146 10F016 003 1		
Sockelgehäuse <i>Housing</i> 		h	1 Kabelabgang / Single side entry		
		64/77	21	C146 10F016 802 1	C146 10F040 803 2
		64/77	21	C146 10F016 502 1 <sup>(*)</sup>	C146 10F040 503 2 <sup>(*)</sup>
		77	29		C146 10F040 802 2
		77	29		C146 10F040 502 2 <sup>(*)</sup>
		1 Geschlossen bei einem Kabelausgang <i>1 closed if single entry</i>		64	21
		77	29		C146 10F040 602 2
Sockelgehäuse mit Deckel <i>Housing with spring cover</i> 		h	1 Kabelabgang / Single side entry		
		64/77	21	C146 10F016 806 1	C146 10F040 807 2
		64/77	21	C146 10F016 506 1 <sup>(*)</sup>	C146 10F040 507 2 <sup>(*)</sup>
		77	29		C146 10F040 806 2
		77	29		C146 10F040 506 2 <sup>(*)</sup>
		1 Geschlossen bei einem Kabelausgang <i>1 closed if single entry</i>		64/77	21
		77	29		C146 10F040 606 2

<sup>1)</sup> incl. Flachdichtung / incl. gasket

<sup>(\*)</sup> links / left

**housings for 1 locking-lever-system according to  
 DIN EN 175 301 - 801 (DIN 43 652)**

- also easy to use for side entry
- cover for housings lockable
- cable to cable possible

**Metrisches Gewinde  
 Metric thread**

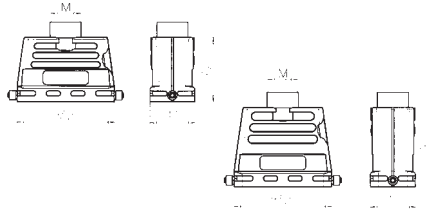
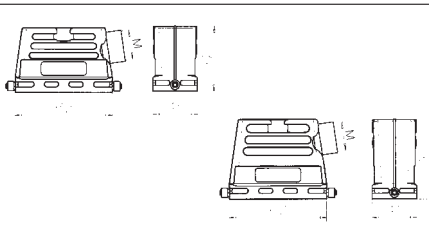
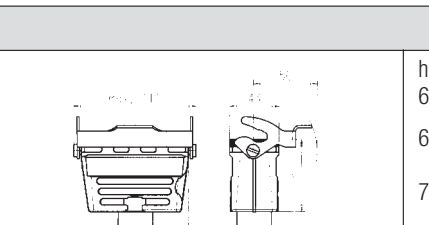
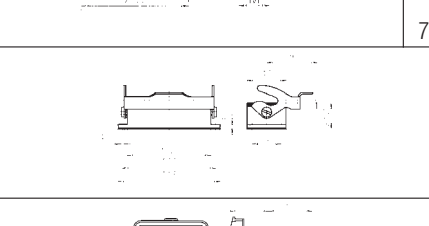
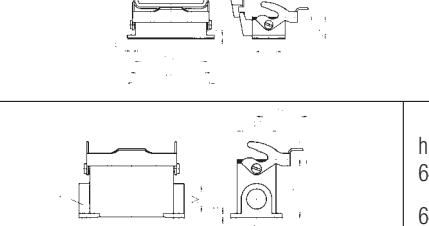
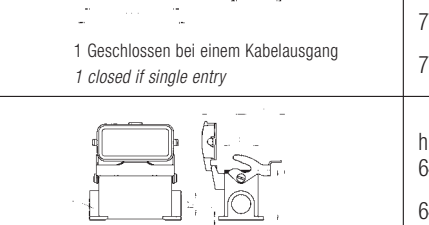
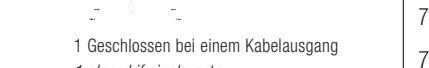
Maßzeichnung Drawing	M	Bestell Nr. / Part No.		Bestell Nr. / Part No.		
		Niedrige Bauform/ Low profile	Hohe Bauform/ High profile	Niedrige Bauform/ Low profile	Hohe Bauform/ High profile	
		mit Stützen / with stud		ohne Stützen / without stud		
	25	C146 10R016 656 1		C146 21R016 656 1		
	32	C146 10R016 606 1		C146 21R016 606 1		
	25		C146 10R016 656 8		C146 21R016 656 8	
	32		C146 10R016 606 8		C146 21R016 606 8	
	40		C146 10R016 607 8		C146 21R016 607 8	
	25	C146 10R016 556 1		C146 21R016 556 1		
	32	C146 10R016 506 1		C146 21R016 506 1		
	25		C146 10R016 556 8		C146 21R016 556 8	
	32		C146 10R016 506 8		C146 21R016 506 8	
	40		C146 10R016 507 8		C146 21R016 507 8	
	h	25	C146 10R016 854 1		C146 21R016 854 1	
	62	32	C146 10R016 804 1		C146 21R016 804 1	
	76	25		C146 10R016 854 8	C146 21R016 854 8	
	76	32		C146 10R016 804 8	C146 21R016 804 8	
	76	40		C146 10R016 805 8	C146 21R016 805 8	
	–	–	C146 10F016 001 1			
	–	C146 10F016 003 1				
	h	25	1 Kabelabgang / Single side entry		2 Kabelabgänge / Double side entry	
 <p>1 Geschlossen bei einem Kabelausgang 1 closed if single entry</p>	64/77	25	C146 10N016 802 1	C146 10N016 803 2	C146 10N016 602 1	C146 10N016 603 2
	64/77	25	C146 10N016 502 1 <sup>(†)</sup>	C146 10N016 503 2 <sup>(†)</sup>	C146 10N016 702 1 <sup>(†+u)</sup>	C146 10N016 703 2 <sup>(†+u)</sup>
	77	32		C146 10N016 802 2		C146 10N016 602 2
	77	32		C146 10N016 502 2 <sup>(†)</sup>		C146 10N016 702 2 <sup>(†+u)</sup>
 <p>1 Geschlossen bei einem Kabelausgang 1 closed if single entry</p>	h	25	1 Kabelabgang / Single side entry		2 Kabelabgänge / Double side entry	
	64/77	25	C146 10N016 806 1	C146 10N016 807 2	C146 10N016 606 1	C146 10N016 607 2
	64/77	25	C146 10N016 506 1 <sup>(†)</sup>	C146 10N016 507 2 <sup>(†)</sup>	C146 10N016 708 1 <sup>(†+u)</sup>	C146 10N016 709 2 <sup>(†+u)</sup>
	77	32		C146 10N016 806 2		C146 10N016 606 2
	77	32		C146 10N016 506 2 <sup>(†)</sup>		C146 10N016 708 2 <sup>(†+u)</sup>

<sup>(†)</sup> links / left

<sup>(†+u)</sup> rechts und unten / right and bottom







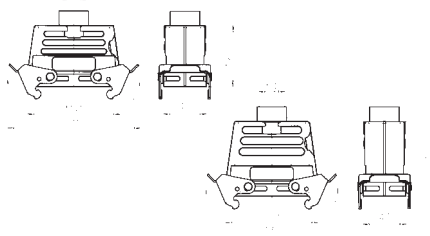

Bei Sockelgehäusen Abgang rechts dargestellt / housings are shown with right outlet

**C 146 E** 16 pol.  
**C 146 M** 5 Module  
**C 146 D** 40 pol.  
**C 146 DD** 72 pol.  
**C 146 HSE** 6 pol.  
**C 146 HvE** 6 pol.  
**C 146 EE** 32 pol.  
 Gehäuse / Housings

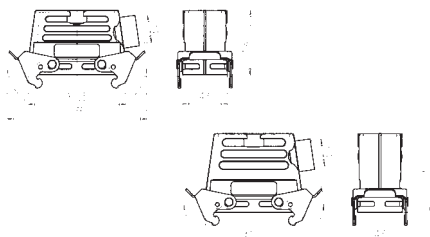
**Tüllengehäuse mit Querbügel nach  
 DIN EN 175 301 - 801 (DIN 43 652)**

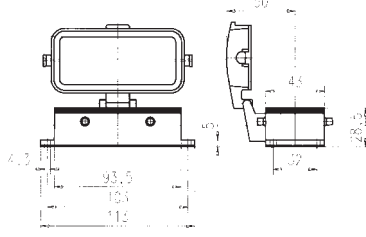
- sichere 4-Punkt Verriegelung
- Gehäuseunterteil mit Schutzdeckel
- keine Bügel am Gehäuseunterteil

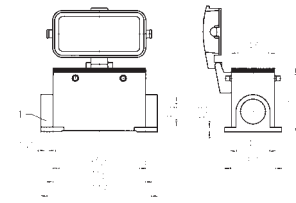
**PG-Gewinde  
 PG-thread**

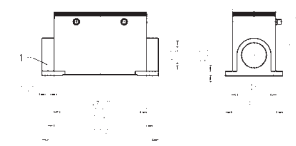
Bezeichnung - Abbildung <i>Description - Figure</i>	Maßzeichnung <i>Drawing</i>	PG	Bestell Nr. / Part No.		
			Niedrige Bauform / Low profile	Hohe Bauform / High profile	
<b>Gehäuseoberteile / Hoods</b>					
Tüllengehäuse, Abgang oben <i>Hood, top entry</i> 		21	C146 10G016 602 1		
		29	C146 10G016 603 1		
		21		C146 10G016 602 8	
		29		C146 10G016 603 8	
Tüllengehäuse, Abgang Seite <i>Hood, side entry</i> 		21	C146 10G016 502 1		
		29	C146 10G016 503 1		
		21		C146 10G016 502 8	
		29		C146 10G016 503 8	
<b>Gehäuseunterteile / Housings</b>					
Anbaugehäuse mit Deckel <sup>1)</sup> <i>Housing, with spring cover <sup>1)</sup></i> 		–	C146 10F016 002 1		
Sockelgehäuse, mit Deckel <i>Housing, with spring cover</i> 		h	1 Kabelabgang / Single side entry		
		64/77	21	C146 10F016 804 1	C146 10F040 805 2
		64/77	21	C146 10F016 504 1 <sup>(1)</sup>	C146 10F040 505 2 <sup>(1)</sup>
		77	29		C146 10F040 804 2
		77	29	C146 10F040 504 2 <sup>(1)</sup>	
	1 Geschlossen bei einem Kabelausgang <i>1 closed if single entry</i>	h	2 Kabelabgänge / Double side entry		
		64/77	21	C146 10F016 604 1	C146 10F040 605 2
		77	29		C146 10F040 604 2
Sockelgehäuse <i>Housing</i> 		h	1 Kabelabgang / Single side entry		
		77	21		C146 10F016 509 2
		77	29		C146 10F016 508 2
		h	2 Kabelabgänge / Double side entry		
		77	21		C146 10F016 609 2
	1 Geschlossen bei einem Kabelausgang <i>1 closed if single entry</i>	77	29		C146 10F016 608 2

<sup>1)</sup>incl. Flachdichtung / incl. gasket

Bei Sockelgehäusen Abgang rechts dargestellt / housings are shown with right out



hoods with 2 locking-levers according to  
DIN EN 175 301 - 801 (DIN 43 652)

- secured 4 point locking
- housing with cover
- no locking levers at the housings

**Metrisches Gewinde**  
**Metric thread**

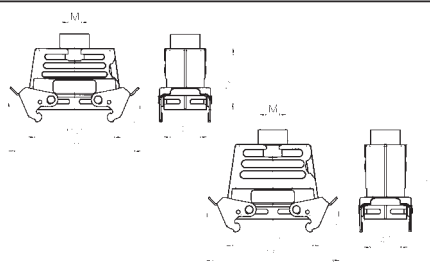
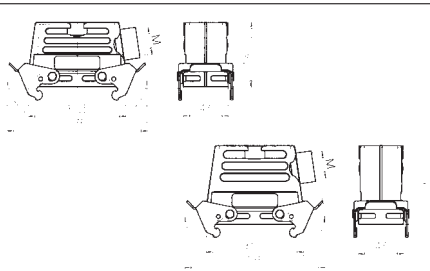
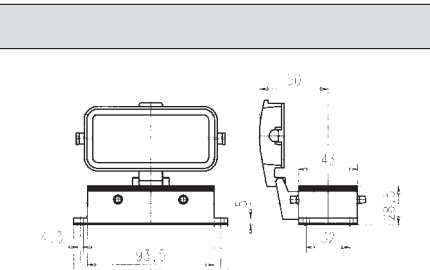
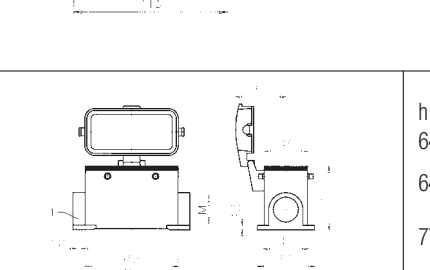
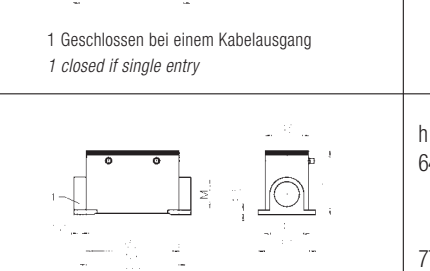
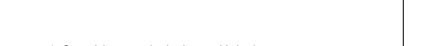
Maßzeichnung Drawing	M	Bestell Nr. / Part No.		Bestell Nr. / Part No.		
		Niedrige Bauform/ Low profile	Hohe Bauform/ High profile	Niedrige Bauform/ Low profile	Hohe Bauform/ High profile	
		mit Stützen / with stud		ohne Stützen / without stud		
	25	C146 10R016 652 1		C146 21R016 652 1		
	32	C146 10R016 602 1		C146 21R016 602 1		
	25		C146 10R016 652 8		C146 21R016 652 8	
	32		C146 10R016 602 8		C146 21R016 602 8	
	25	C146 10R016 552 1		C146 21R016 552 1		
	32	C146 10R016 502 1		C146 21R016 502 1		
	25		C146 10R016 552 8		C146 21R016 552 8	
	32		C146 10R016 502 8		C146 21R016 502 8	
	40		C146 10R016 603 8		C146 21R016 603 8	
	—	C146 10F016 002 1				
 <p>1 Geschlossen bei einem Kabelausgang 1 closed if single entry</p>	h	1 Kabelabgang / Single side entry		2 Kabelabgänge / Double side entry		
	64/77	25	C146 10N016 804 1	C146 10N016 805 2	C146 10N016 604 1	C146 10N016 605 2
	64/77	25	C146 10N016 504 1 <sup>(†)</sup>	C146 10N016 505 2 <sup>(†)</sup>	C146 10N016 808 1 <sup>(†+u)</sup>	C146 10N016 809 2 <sup>(†+u)</sup>
	77	32		C146 10N016 804 2		C146 10N016 604 2
 <p>1 Geschlossen bei einem Kabelausgang 1 closed if single entry</p>	h	1 Kabelabgang / Single side entry		2 Kabelabgänge / Double side entry		
	64/77	25	C146 10N016 508 1	C146 10N016 509 2	C146 10N016 608 1	C146 10N016 609 2
	77	32		C146 10N016 508 2		C146 10N016 608 2

<sup>(†)</sup> links / left





<sup>(†+u)</sup> rechts und unten / right and bottom

**C 146 E** 16 pol.  
**C 146 M** 5 Module  
**C 146 D** 40 pol.  
**C 146 DD** 72 pol.  
**C 146 HSE** 6 pol.  
**C 146 HvE** 6 pol.  
**C 146 EE** 32 pol.  
 Gehäuse / Housings

**Sondergehäuse für Querbügelverriegelung, nach  
 DIN EN 175 301 - 801 (DIN 43 652)**

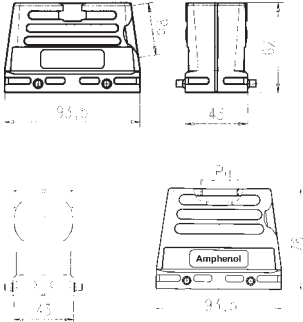
*special housings for 2 locking-lever system,  
 according to DIN EN 175 301 - 801 (DIN 43 652)*

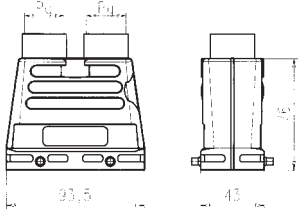
**PG-Gewinde  
 PG-thread**

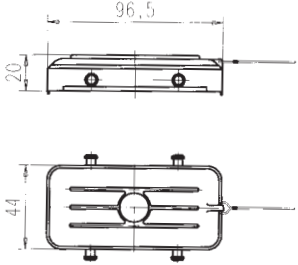
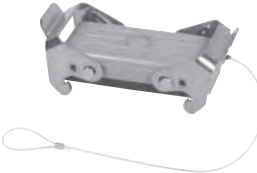
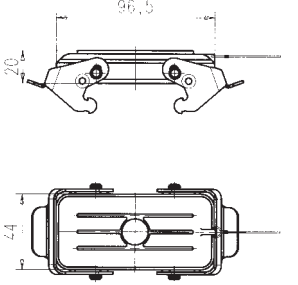
Bezeichnung - Abbildung <i>Description - Figure</i>	Maßzeichnung <i>Drawing</i>	PG	Kabelabgang <i>cabl e outlet</i>	Bestell Nr. / <i>Part No.</i>	
				Niedrige Bauform / <i>Low profile</i>	Hohe Bauform / <i>High profile</i>
<b>Gehäuseoberteile / Hoods</b>					
Tüllengehäuse ohne Stutzen <i>Hood without stud</i>  		21	Oben / <i>top</i>  Seite / <i>side</i>	C146 21G016 600 1	
				29	Oben / <i>top</i>  Seite / <i>side</i>
Tüllengehäuse, 2 x Abgang Oben <i>Hood, 2 top entry</i>  		21			C146 10G016 902 8
<b>Schutzkappen / Protective cover</b>					
Schutzkappe für Gehäuseunterteile <i>Cover for housings</i>  		—		C146 10Z016 100 1	
Schutzkappe für Gehäuseoberteile <i>Cover for hoods</i>  		—		C146 10Z016 200 1	





Verschraubung für Tüllen- und Sockelgehäuse siehe Seite 170-173 / *gland bushings for hoods and housing see page 170-173*

**C 146 E** 16 pol.  
**C 146 M** 5 Module  
**C 146 D** 40 pol.  
**C 146 DD** 72 pol.  
**C 146 HSE** 6 pol.  
**C 146 HvE** 6 pol.  
**C 146 EE** 32 pol.  
 Gehäuse / Housings

**Sondergehäuse für Querbügelverriegelung, nach  
 DIN EN 175 301 - 801 (DIN 43 652)**

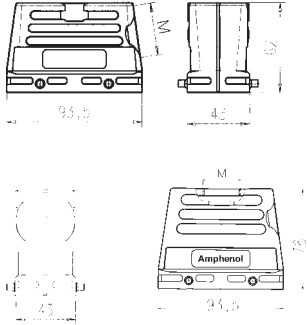
*special housings for 2 locking-lever system,  
 according to DIN EN 175 301 - 801 (DIN 43 652)*

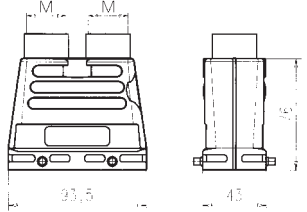
**Metrisches Gewinde  
 Metric thread**

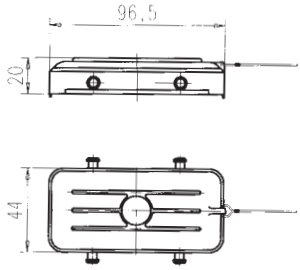
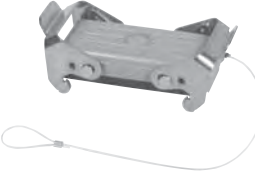
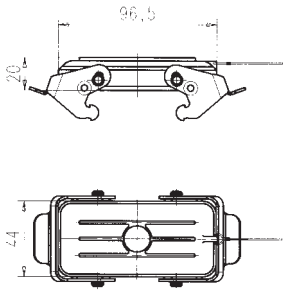
Bezeichnung - Abbildung <i>Description - Figure</i>	Maßzeichnung <i>Drawing</i>	M	Kabelabgang <i>cabl e outlet</i>	Bestell Nr. / <i>Part No.</i>	
				Niedrige Bauform / <i>Low profile</i>	Hohe Bauform / <i>High profile</i>
<b>Gehäuseoberteile / Hoods</b>					
Tüllengehäuse ohne Stutzen <i>Hood without stud</i>  		25	Oben / <i>top</i>	C146 21R016 650 1	C146 21R016 650 8
			Seite / <i>side</i>	C146 21R016 550 1	C146 21R016 550 8
		32	Oben / <i>top</i>	C146 21R016 600 1	C146 21R016 600 8
			Seite / <i>side</i>	C146 21R016 500 1	C146 21R016 500 8
Tüllengehäuse, 2 x Abgang Oben <i>Hood, 2 top entry</i>  		25			C146 10R016 910 8
		32			C146 10R016 902 8
<b>Schutzkappen / Protective cover</b>					
Schutzkappe für Gehäuseunterteile <i>Cover for housings</i>  		—		C146 10Z016 100 1	
Schutzkappe für Gehäuseoberteile <i>Cover for hoods</i>  		—		C146 10Z016 200 1	

Verschraubung für Tüllen- und Sockelgehäuse siehe Seite 170-173 / *gland bushings for hoods and housing see page 170-173*







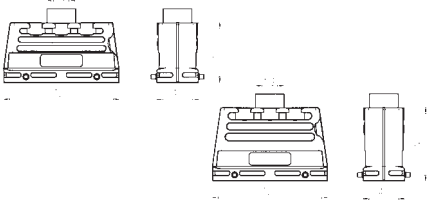

C 146 E 24 pol.  
 C 146 M 7 Module  
 C 146 D 64 pol.  
 C 146 DD 108 pol.  
 C 146 HvE 10 pol.  
 C 146 EE 46 pol.

Gehäuse / Housings

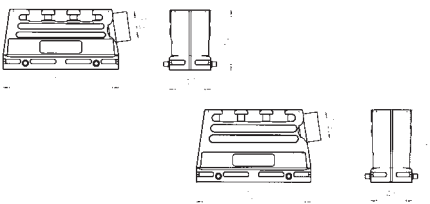
Gehäuse für Querbügelverriegelung nach  
 DIN EN 175 301 - 801 (DIN 43 652)

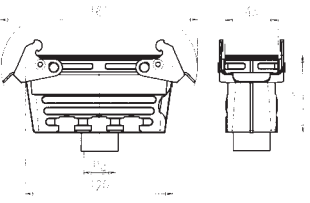
- sichere 4-Punkt Verriegelung
- bevorzugt bei seitlicher Anreihung
- fliegende Verbindung möglich

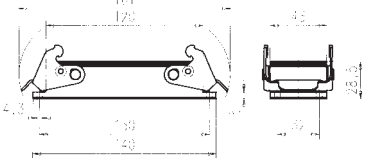
PG-Gewinde  
 PG-thread

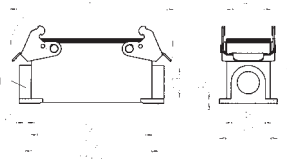
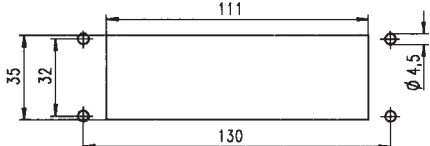
Bezeichnung - Abbildung <i>Description - Figure</i>	Maßzeichnung <i>Drawing</i>	PG	Bestell Nr. / Part No.		
			Niedrige Bauform / Low profile	Hohe Bauform / High profile	
<b>Gehäuseoberteile / Hoods</b>					
Tüllengehäuse, Abgang oben <i>Hood, top entry</i> 		21	C146 10G024 600 1		
		29	C146 10G024 601 1		
		21		C146 10G024 600 8	
		29		C146 10G024 601 8	
Tüllengehäuse, Abgang Seite <i>Hood, side entry</i> 		21	C146 10G024 500 1		
		29	C146 10G024 501 1		
		21		C146 10G024 500 8	
		29		C146 10G024 501 8	
<b>Gehäuseunterteile / Housings</b>					
Kupplungsgehäuse <i>Hood, coupling application</i> 		h			
		62	21	C146 10G024 802 1	
		62	29	C146 10G024 803 1	
		76	21		C146 10G024 802 8
76	29		C146 10G024 803 8		
Anbaugehäuse <sup>1)</sup> <i>Housing, bulkhead mounting <sup>1)</sup></i> 				C146 10F024 000 1	
Sockelgehäuse <i>Housing</i> 		h	1 Kabelabgang / Single side entry		
		64/80	21	C146 10F024 500 1	C146 10F064 501 2
		80	29		C146 10F064 500 2
		h	2 Kabelabgänge / Double side entry		
		64/80	21	C146 10F024 600 1	C146 10F064 601 2
		80	29		C146 10F064 600 2
<b>Montageausschnitt für Anbaugehäuse / Panel cut out for housing bulkhead mounting</b>					
					

<sup>1)</sup> incl. Flachdichtung / incl. gasket

Verschraubung für Tüllen- und Sockelgehäuse siehe Seite 170-173 / gland bushings for hoods and housing see page 170-173

**housings for 2 locking-lever-system according to  
 DIN EN 175 301 - 801 (DIN 43 652)**

- **secured 4 point locking**
- **preferred for side by side mounting**
- **cable to cable possible**

**Metrisches Gewinde  
Metric thread**

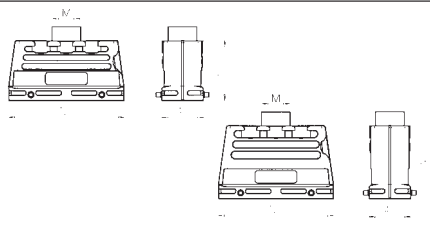
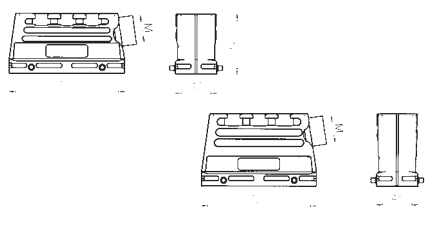
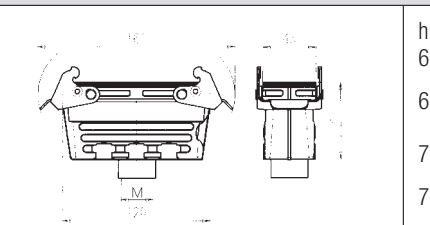
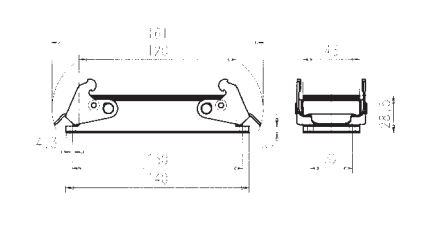
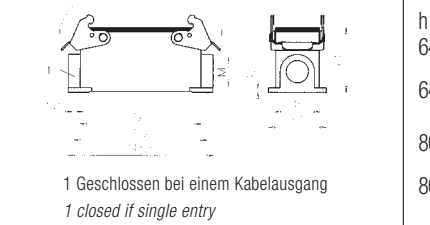
Maßzeichnung <i>Drawing</i>	M	Bestell Nr. / <i>Part No.</i>		Bestell Nr. / <i>Part No.</i>		
		Niedrige Bauform/ <i>Low profile</i>	Hohe Bauform/ <i>High profile</i>	Niedrige Bauform/ <i>Low profile</i>	Hohe Bauform/ <i>High profile</i>	
		mit Stützen / <i>with stud</i>		ohne Stützen / <i>without stud</i>		
	25	C146 10R024 650 1		C146 21R024 650 1		
	32	C146 10R024 600 1		C146 21R024 600 1		
	25		C146 10R024 650 8		C146 21R024 650 8	
	32		C146 10R024 600 8		C146 21R024 600 8	
	25	C146 10R024 550 1		C146 21R024 550 1		
	32	C146 10R024 500 1		C146 21R024 500 1		
	25		C146 10R024 550 8		C146 21R024 550 8	
	32		C146 10R024 500 8		C146 21R024 500 8	
	25	C146 10R024 852 1		C146 21R024 852 1		
	32	C146 10R024 802 1		C146 21R024 802 1		
	25		C146 10R024 852 8		C146 21R024 852 8	
	32		C146 10R024 802 8		C146 21R024 802 8	
	—	C146 10F024 000 1				
 <p>1 Geschlossen bei einem Kabelausgang 1 closed if single entry</p>	h	1 Kabelabgang / <i>Single side entry</i>		2 Kabelabgänge / <i>Double side entry</i>		
	64/80	25	C146 10N024 500 1	C146 10N024 501 2	C146 10N024 600 1	C146 10N024 601 2
	64/80	25			C146 10N024 700 1 <sup>(r+u)</sup>	C146 10N024 701 2 <sup>(r+u)</sup>
	80	32		C146 10N024 500 2		C146 10N024 600 2
	80	32			C146 10N024 700 2 <sup>(r+u)</sup>	

<sup>(r+u)</sup> rechts und unten / *right and bottom*

Bei Sockelgehäusen Abgang rechts dargestellt /  *housings are shown with right out*











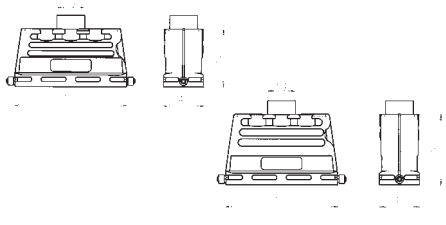

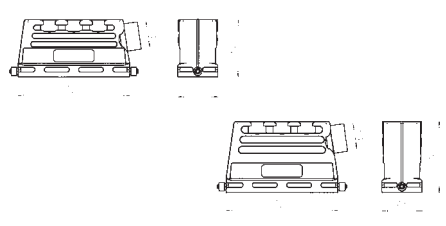
C 146 E 24 pol.  
 C 146 M 7 Module  
 C 146 D 64 pol.  
 C 146 DD 108 pol.  
 C 146 HvE 10 pol.  
 C 146 EE 46 pol.

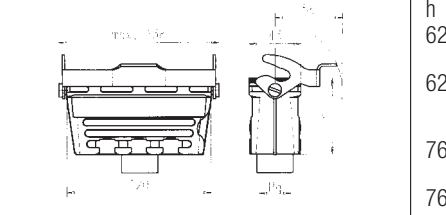
Gehäuse / Housings

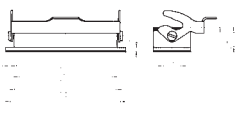
Gehäuse für Längsbügelverriegelung nach  
 DIN EN 175 301 - 801 (DIN 43 652)

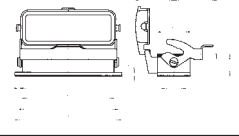
- leichtes Bedienen auch bei seitlichem Kabelabgang
- Schutzkappe am Gehäuseunterteil verriegelbar
- fliegende Verbindung möglich

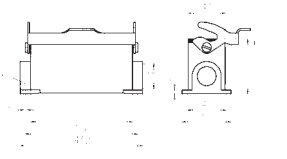
PG-Gewinde  
 PG-thread

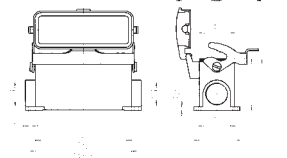
Bezeichnung - Abbildung Description - Figure	Maßzeichnung Drawing	PG	Bestell Nr. / Part No.		
			Niedrige Bauform / Low profile	Hohe Bauform / High profile	
<b>Gehäuseoberteile / Hoods</b>					
Tüllengehäuse, Abgang oben Hood, top entry 		21	C146 10G024 606 1		
		29	C146 10G024 607 1		
		21		C146 10G024 606 8	
		29		C146 10G024 607 8	
Tüllengehäuse, Abgang Seite Hood, side entry 		21	C146 10G024 506 1		
		29	C146 10G024 507 1		
		21		C146 10G024 506 8	
		29		C146 10G024 507 8	
<b>Gehäuseunterteile / Housings</b>					
Kupplungsgehäuse Hood, coupling application 		h			
		62	21	C146 10G024 804 1	
		62	29	C146 10G024 805 1	
		76	21		C146 10G024 804 8
76	29		C146 10G024 805 8		
Anbaugehäuse <sup>1)</sup> Housing, bulkhead mounting <sup>1)</sup> 				C146 10F024 001 1	
Anbaugehäuse mit Deckel <sup>1)</sup> Housing with spring cover <sup>1)</sup> 				C146 10F024 003 1	
Sockelgehäuse Housing 		h	1 Kabelabgang / Single side entry		
		64/80	21	C146 10F024 802 1	C146 10F064 803 2
		64/80	21	C146 10F024 502 1 <sup>(1)</sup>	C146 10F064 503 2 <sup>(1)</sup>
		80	29		C146 10F064 802 2
		80	29		C146 10F064 502 2 <sup>(1)</sup>
					2 Kabelabgänge / Double side entry
		64/80	21	C146 10F024 602 1	C146 10F064 603 2
		80	29		C146 10F064 602 2
Sockelgehäuse mit Deckel Housing with spring cover 		h	1 Kabelabgang / Single side entry		
		64/80	21	C146 10F024 806 1	C146 10F064 807 2
		64/80	21	C146 10F024 506 1 <sup>(1)</sup>	C146 10F064 507 2 <sup>(1)</sup>
		80	29		C146 10F064 806 2
		80	29		C146 10F064 506 2 <sup>(1)</sup>
					2 Kabelabgänge / Double side entry
		64/80	21	C146 10F024 606 1	C146 10F064 607 2
		80	29		C146 10F064 606 2

<sup>1)</sup> incl. Flachdichtung / incl. flat gasket

Bei Sockelgehäusen Abgang rechts dargestellt / housings are shown with right out



**housings for 1 locking-lever-system according to  
 DIN EN 175 301 - 801 (DIN 43 652)**

- also easy to use for side entry
- cover for housings lockable
- cable to cable possible

**Metrisches Gewinde  
Metric thread**

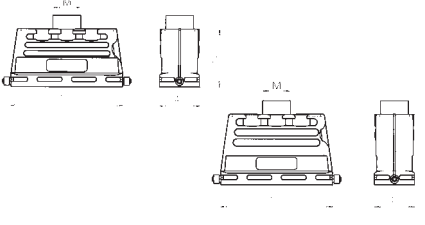
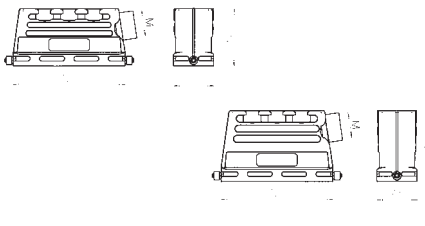
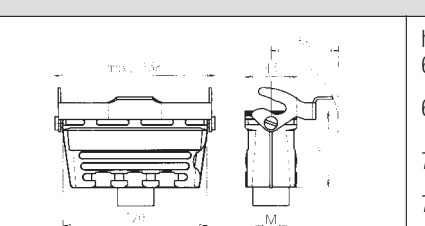
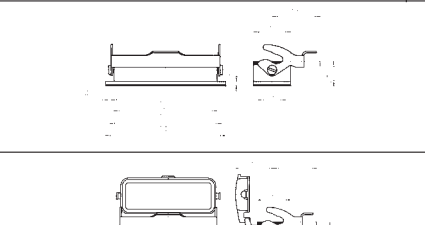
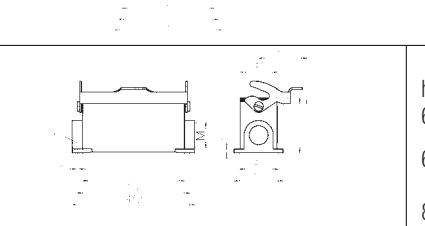
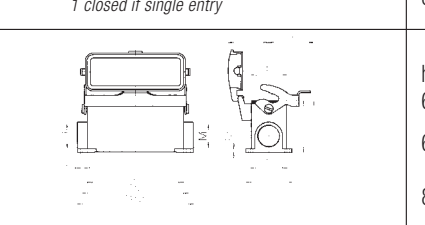
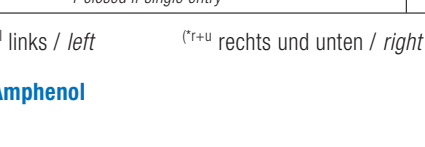
Maßzeichnung <i>Drawing</i>	M	Bestell Nr. / Part No.		Bestell Nr. / Part No.		
		Niedrige Bauform/ <i>Low profile</i>	Hohe Bauform/ <i>High profile</i>	Niedrige Bauform/ <i>Low profile</i>	Hohe Bauform/ <i>High profile</i>	
		mit Stützen / <i>with stud</i>		ohne Stützen / <i>without stud</i>		
	25	C146 10R024 656 1		C146 21R024 656 1		
	32	C146 10R024 606 1		C146 21R024 606 1		
	25		C146 10R024 656 8		C146 21R024 656 8	
	32		C146 10R024 606 8		C146 21R024 606 8	
	40		C146 10R024 607 8		C146 21R024 607 8	
	25	C146 10R024 556 1		C146 21R024 556 1		
	32	C146 10R024 506 1		C146 21R024 506 1		
	25		C146 10R024 556 8		C146 21R024 556 8	
	32		C146 10R024 506 8		C146 21R024 506 8	
	40		C146 10R024 507 8		C146 21R024 507 8	
	h	25	C146 10R024 854 1		C146 21R024 854 1	
	62	32	C146 10R024 804 1		C146 21R024 804 1	
	76	25	C146 10R024 854 8		C146 21R024 854 8	
	76	32	C146 10R024 804 8		C146 21R024 804 8	
	76	40	C146 10R024 805 8		C146 21R024 805 8	
	–	–	C146 10F024 001 1			
	–	–	C146 10F024 003 1			
	h	25	1 Kabelabgang / <i>Single side entry</i>		2 Kabelabgänge / <i>Double side entry</i>	
 <p>1 Geschlossen bei einem Kabelausgang <i>1 closed if single entry</i></p>	64/80	25	C146 10N024 802 1	C146 10N024 803 2	C146 10N024 602 1	C146 10N024 603 2
	64/80	25	C146 10N024 502 1 <sup>(*)</sup>	C146 10N024 503 2 <sup>(*)</sup>	C146 10N024 702 1 <sup>(r+u)</sup>	C146 10N024 703 2 <sup>(r+u)</sup>
	80	32		C146 10N024 802 2		C146 10N024 602 2
	80	32		C146 10N024 502 2 <sup>(*)</sup>		C146 10N024 702 2 <sup>(r+u)</sup>
 <p>1 Geschlossen bei einem Kabelausgang <i>1 closed if single entry</i></p>	h	25	1 Kabelabgang / <i>Single side entry</i>		2 Kabelabgänge / <i>Double side entry</i>	
	64/80	25	C146 10N024 806 1	C146 10N024 807 2	C146 10N024 606 1	C146 10N024 607 2
	64/80	25	C146 10N024 506 1 <sup>(*)</sup>	C146 10N024 507 2 <sup>(*)</sup>	C146 10N024 708 1 <sup>(r+u)</sup>	C146 10N024 709 2 <sup>(r+u)</sup>
	80	32		C146 10N024 806 2		C146 10N024 606 2
	80	32		C146 10N024 506 2 <sup>(*)</sup>		C146 10N024 708 2 <sup>(r+u)</sup>

<sup>(\*)</sup> links / *left*

<sup>(r+u)</sup> rechts und unten / *right and bottom*







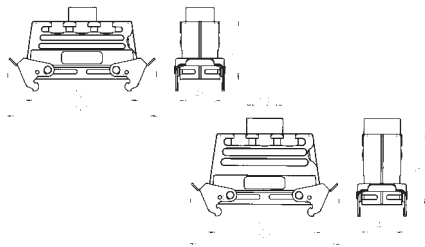

**C 146 E** 24 pol.  
**C 146 M** 7 Module  
**C 146 D** 64 pol.  
**C 146 DD** 108 pol.  
**C 146 HvE** 10 pol.  
**C 146 EE** 46 pol.

Gehäuse / Housings

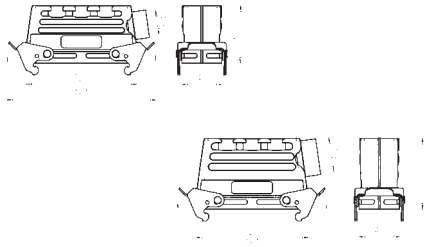
**Tüllengehäuse mit Querbügel nach  
 DIN EN 175 301 - 801 (DIN 43 652 )**

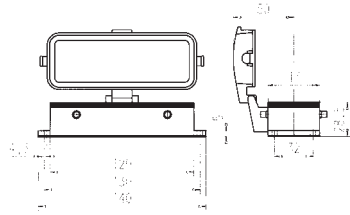
- sichere 4-Punkt Verriegelung
- Gehäuseunterteil mit Schutzdeckel
- keine Bügel am Gehäuseunterteil

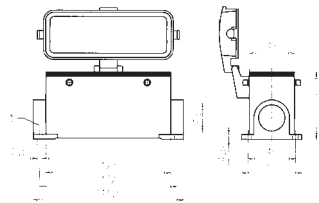
**PG-Gewinde  
 PG-thread**

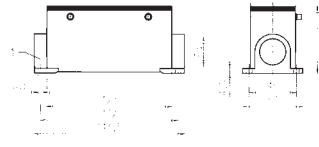
Bezeichnung - Abbildung <i>Description - Figure</i>	Maßzeichnung <i>Drawing</i>	PG	Bestell Nr. / Part No.				
			Niedrige Bauform / Low profile	Hohe Bauform / High profile			
<b>Gehäuseoberteile / Hoods</b>							
Tüllengehäuse, Abgang oben <i>Hood, top entry</i> 		21	C146 10G024 602 1	C146 10G024 602 8 C146 10G024 603 8			
		29	C146 10G024 603 1				
		21					
		29					
Tüllengehäuse, Abgang Seite <i>Hood, side entry</i> 		21	C146 10G024 502 1	C146 10G024 502 8 C146 10G024 503 8			
		29	C146 10G024 503 1				
		21					
		29					
<b>Gehäuseunterteile / Housings</b>							
Anbaugehäuse mit Deckel <sup>1)</sup> <i>Housing, with spring cover <sup>1)</sup></i> 		–	C146 10F024 002 1				
Sockelgehäuse, mit Deckel <i>Housing, with spring cover</i> 		h	1 Kabelabgang / Single side entry				
			64/80	21	C146 10F024 804 1	C146 10F064 805 2	
		64/80	21	C146 10F024 504 1 <sup>(1)</sup>	C146 10F064 505 2 <sup>(1)</sup>		
		80	29		C146 10F064 804 2		
		80	29		C146 10F064 504 2 <sup>(1)</sup>		
		2 Kabelabgänge / Double side entry		64/80	21	C146 10F024 604 1	C146 10F064 605 2
1 Geschlossen bei einem Kabelausgang <i>1 closed if single entry</i>		80	29		C146 10F064 604 2		
Sockelgehäuse <i>Housing</i> 		h	1 Kabelabgang / Single side entry				
			80	21		C146 10F024 509 2	
		80	29		C146 10F024 508 2		
		2 Kabelabgänge / Double side entry		80	21		C146 10F024 609 2
		1 Geschlossen bei einem Kabelausgang <i>1 closed if single entry</i>		80	29		C146 10F024 608 2

<sup>1)</sup> incl. Flachdichtung / incl. gasket

Bei Sockelgehäusen Abgang rechts dargestellt / housings are shown with right out

hoods with 2 locking-levers according to  
DIN EN 175 301 - 801 (DIN 43 652)

- secured 4 point locking
- housing with cover
- no locking levers at the housings

Metrisches Gewinde  
Metric thread

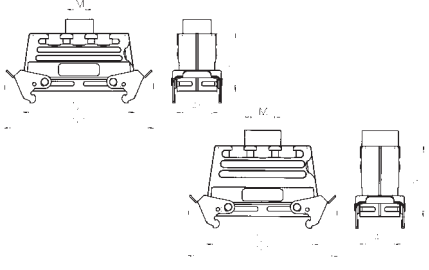
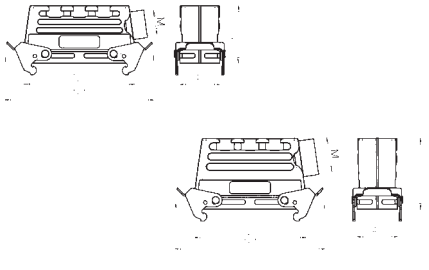
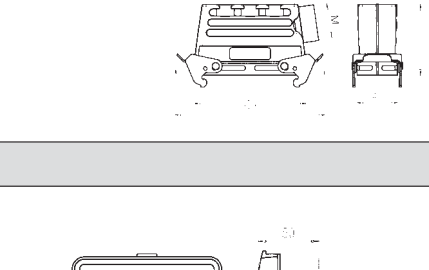
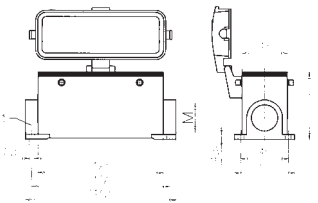
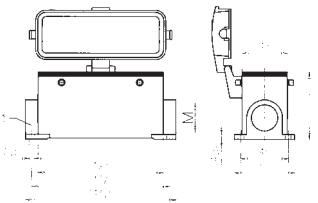
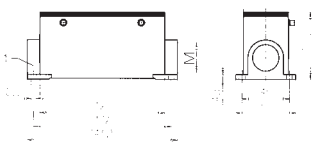
Maßzeichnung Drawing	M	Bestell Nr. / Part No.		Bestell Nr. / Part No.		
		Niedrige Bauform/ Low profile	Hohe Bauform/ High profile	Niedrige Bauform/ Low profile	Hohe Bauform/ High profile	
		mit Stützen / with stud		ohne Stützen / without stud		
	25	C146 10R024 652 1		C146 21R024 652 1		
	32	C146 10R024 602 1		C146 21R024 602 1		
	25		C146 10R024 652 8		C146 21R024 652 8	
	32		C146 10R024 602 8		C146 21R024 602 8	
	40		C146 10R024 603 8		C146 21R024 603 8	
	25	C146 10R024 552 1		C146 21R024 552 1		
	32	C146 10R024 502 1		C146 21R024 502 1		
	25		C146 10R024 552 8		C146 21R024 552 8	
	32		C146 10R024 502 8		C146 21R024 502 8	
	40		C146 10R024 503 8		C146 21R024 503 8	
	C146 10F024 002 1					
						
 <p>1 Geschlossen bei einem Kabelausgang 1 closed if single entry</p>	h	1 Kabelabgang / Single side entry		2 Kabelabgänge / Double side entry		
	64/80	25	C146 10N024 804 1	C146 10N024 805 2	C146 10N024 604 1	C146 10N024 605 2
	64/80	25	C146 10N024 504 1 <sup>(*)</sup>	C146 10N024 505 2 <sup>(*)</sup>	C146 10N024 808 1 <sup>(r+u)</sup>	C146 10N024 809 2 <sup>(r+u)</sup>
	80	32		C146 10N024 804 2		C146 10N024 604 2
	80	32		C146 10N024 504 2 <sup>(*)</sup>		C146 10N024 808 2 <sup>(r+u)</sup>
	 <p>1 Geschlossen bei einem Kabelausgang 1 closed if single entry</p>					
	h	1 Kabelabgang / Single side entry		2 Kabelabgänge / Double side entry		
	64/80	25	C146 10N024 508 1	C146 10N024 509 2	C146 10N024 608 1	C146 10N024 609 2
80	32		C146 10N024 508 2		C146 10N024 608 2	

(\*) links / left

(r+u) rechts und unten / right and bottom







C 146 E 24 pol.  
 C 146 M 7 Module  
 C 146 D 64 pol.  
 C 146 DD 108 pol.  
 C 146 HvE 10 pol.  
 C 146 EE 46 pol.

Gehäuse, Schutzkappen  
 Housings, covers

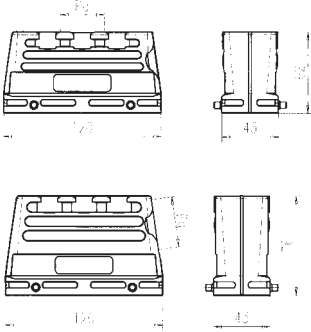
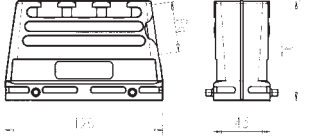
Sondergehäuse für Querbügelverriegelung, nach  
 DIN EN 175 301 - 801 (DIN 43 652)

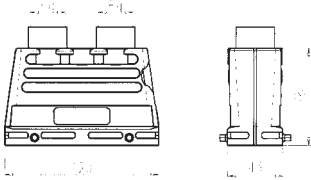
special housings for 2 locking-lever systems,  
 according to DIN EN 175 301 - 801 (DIN 43 652)

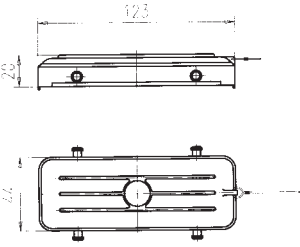
PG-Gewinde  
 PG-thread

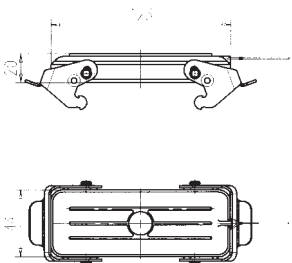
Bezeichnung - Abbildung Description - Figure	Maßzeichnung Drawing	PG	Kabelabgang cable outlet	Bestell Nr. / Part No.	
				Niedrige Bauform / Low profile	Hohe Bauform / High profile
<b>Gehäuseoberteile / Hoods</b>					
Tüllengehäuse ohne Stutzen Hood without stud 		21	Oben / top	C146 21G024 600 1	
			Seite / side	C146 21G024 500 1	
		29	Oben / top		C146 21G024 601 8
			Seite / side		C146 21G024 501 8
Tüllengehäuse, 2 x Abgang Oben Hood, 2 top entry 		21			C146 10G024 903 8
			29		
<b>Schutzkappen / covers</b>					
Schutzkappe für Gehäuseunterteile Cover for housings 		-			C146 10Z024 100 1
Schutzkappe für Gehäuseoberteile Cover for hoods 		-			C146 10Z024 200 1

Verschraubung für Tüllen- und Sockelgehäuse siehe Seite 170-173 / gland bushings for hoods and housing see page 170-173







C 146 E 24 pol.  
 C 146 M 7 Module  
 C 146 D 64 pol.  
 C 146 DD 108 pol.  
 C 146 HvE 10 pol.  
 C 146 EE 46 pol.

Gehäuse, Schutzkappen  
 Housings, covers

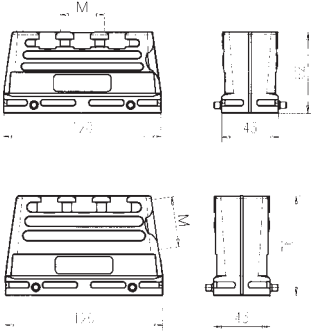
Sondergehäuse für Querbügelverriegelung, nach  
 DIN EN 175 301 - 801 (DIN 43 652)

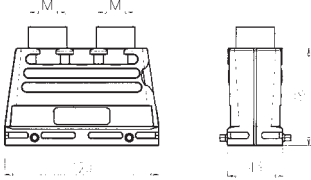
special housings for 2 locking-lever systems,  
 according to DIN EN 175 301 - 801 (DIN 43 652)

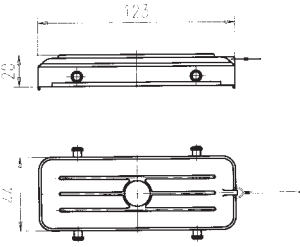
Metrisches Gewinde  
 Metric thread

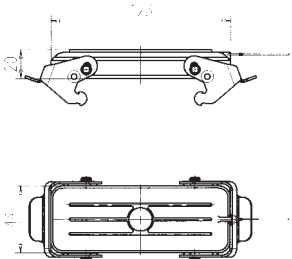
Bezeichnung - Abbildung Description - Figure	Maßzeichnung Drawing	M	Kabelabgang cable outlet	Bestell Nr. / Part No.	
				Niedrige Bauform / Low profile	Hohe Bauform / High profile
<b>Gehäuseoberteile / Hoods</b>					
Tüllengehäuse ohne Stutzen Hood without stud  		25	Oben / top	C146 21R024 650 1	C146 21R024 650 8
			Seite / side	C146 21R024 600 1	C146 21R024 550 8
		32	Oben / top	C146 21R024 500 1	C146 21R024 600 8
			Seite / side		C146 21R024 500 8
Tüllengehäuse, 2 x Abgang Oben Hood, 2 top entry  		32/40			C146 10R024 909 8
		32			C146 10R024 903 8
		40			C146 10R024 908 8
<b>Schutzkappen / covers</b>					
Schutzkappe für Gehäuseunterteile Cover for housings  		—		C146 10Z024 100 1	
Schutzkappe für Gehäuseoberteile Cover for hoods  		—		C146 10Z024 200 1	

Verschraubung für Tüllen- und Sockelgehäuse siehe Seite 170-173 / gland bushings for hoods and housing see page 170-173

**C 146 HvE 16 pol.**

Gehäuse für Querbügelverriegelung nach  
DIN EN 175 301 - 801 (DIN 43 652)







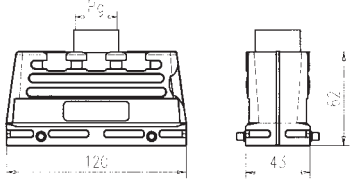

housings for 2 locking-lever-system according to  
DIN EN 175 301 - 801 (DIN 43 652)

- mit Isolationsauskleidung
- ohne Kodiersteg

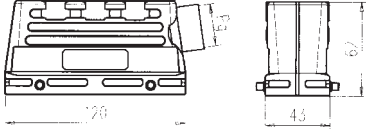
- with insulation inside
- with removed coding element

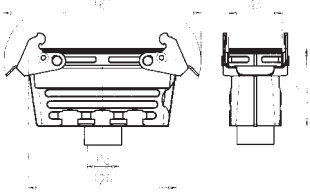
Gehäuse  
Housings

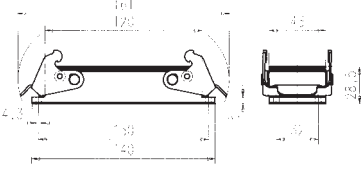
PG-Gewinde  
PG-thread

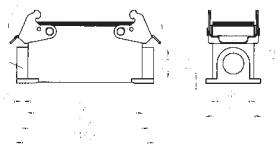
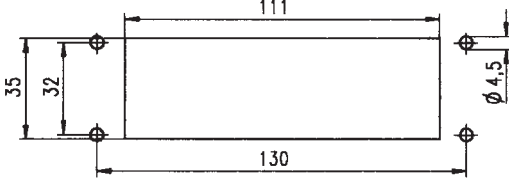
Bezeichnung - Abbildung Description - Figure	Maßzeichnung Drawing	PG	Bestell Nr. / Part No. Niedrige Bauform / Low profile
<b>Gehäuseoberteile / Hoods</b>			
Tüllengehäuse, Abgang oben Hood, top entry 		21	C146 10G024 600 3
Tüllengehäuse, Abgang Seite Hood, side entry 		21	C146 10G024 500 3
<b>Gehäuseunterteile / Housings</b>			
Kupplungsgehäuse Hood, coupling application 		21	C146 10G024 802 3
Anbaugehäuse <sup>1)</sup> Housing, bulkhead mounting <sup>1)</sup> 		-	C146 10F024 000 3
Sockelgehäuse Housing 	  1 Geschlossen bei einem Kabelausgang 1 closed if single entry	21	1 Kabelabgang / Single side entry
			C146 10F024 500 3
<b>Montageausschnitt für Anbaugehäuse / Panel cut out for housing bulkhead mounting</b>			
			

<sup>1)</sup> incl. Flachdichtung / incl. gasket

Verschraubung für Tüllen- und Sockelgehäuse siehe Seite 170-173 / gland bushings for hoods and housing see page 170-173



# C 146 HvE 16 pol.

Gehäuse für Querbügelverriegelung nach  
DIN EN 175 301 - 801 (DIN 43 652)







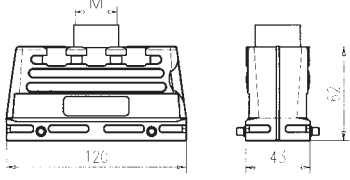

housings for 2 locking-lever-system according to  
DIN EN 175 301 - 801 (DIN 43 652)

- mit Isolationsauskleidung
- ohne Kodiersteg

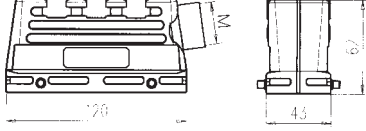
- with insulation inside
- with removed coding element

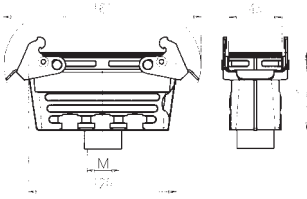
Gehäuse  
Housings

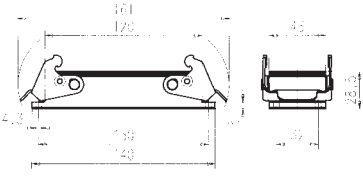
Metrisches Gewinde  
Metric thread

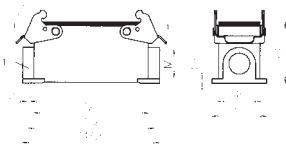
Bezeichnung - Abbildung Description - Figure	Maßzeichnung Drawing	M	Bestell Nr. / Part No. Niedrige Bauform / Low profile	
<b>Gehäuseoberteile / Hoods</b>				
Tüllengehäuse, Abgang oben Hood, top entry  		25	C146 10R024 650 3	
		32	C146 10R024 600 3	
Tüllengehäuse, Abgang Seite Hood, side entry  		25	C146 10R024 550 3	
		32	C146 10R024 500 3	
<b>Gehäuseunterteile / Housings</b>				
Kupplungsgehäuse Hood, coupling application  		25	C146 10R024 852 3	
		32	C146 10R024 802 3	
Anbaugehäuse <sup>1)</sup> Housing, bulkhead mounting <sup>1)</sup>  		–	C146 10F024 000 3	
Sockelgehäuse Housing  	 <p>1 Geschlossen bei einem Kabelausgang 1 closed if single entry</p>	25	1 Kabelabgang / Single side entry	2 Kabelabgänge / 2 side entry
			C146 10N024 500 3	C146 10N024 600 3

<sup>1)</sup> incl. Flachdichtung / incl. gasket

Verschraubung für Tüllen- und Sockelgehäuse siehe Seite 170-173 / gland bushings for hoods and housing see page 170-173



# C 146 EMV Gehäuse / *EMC Housings*

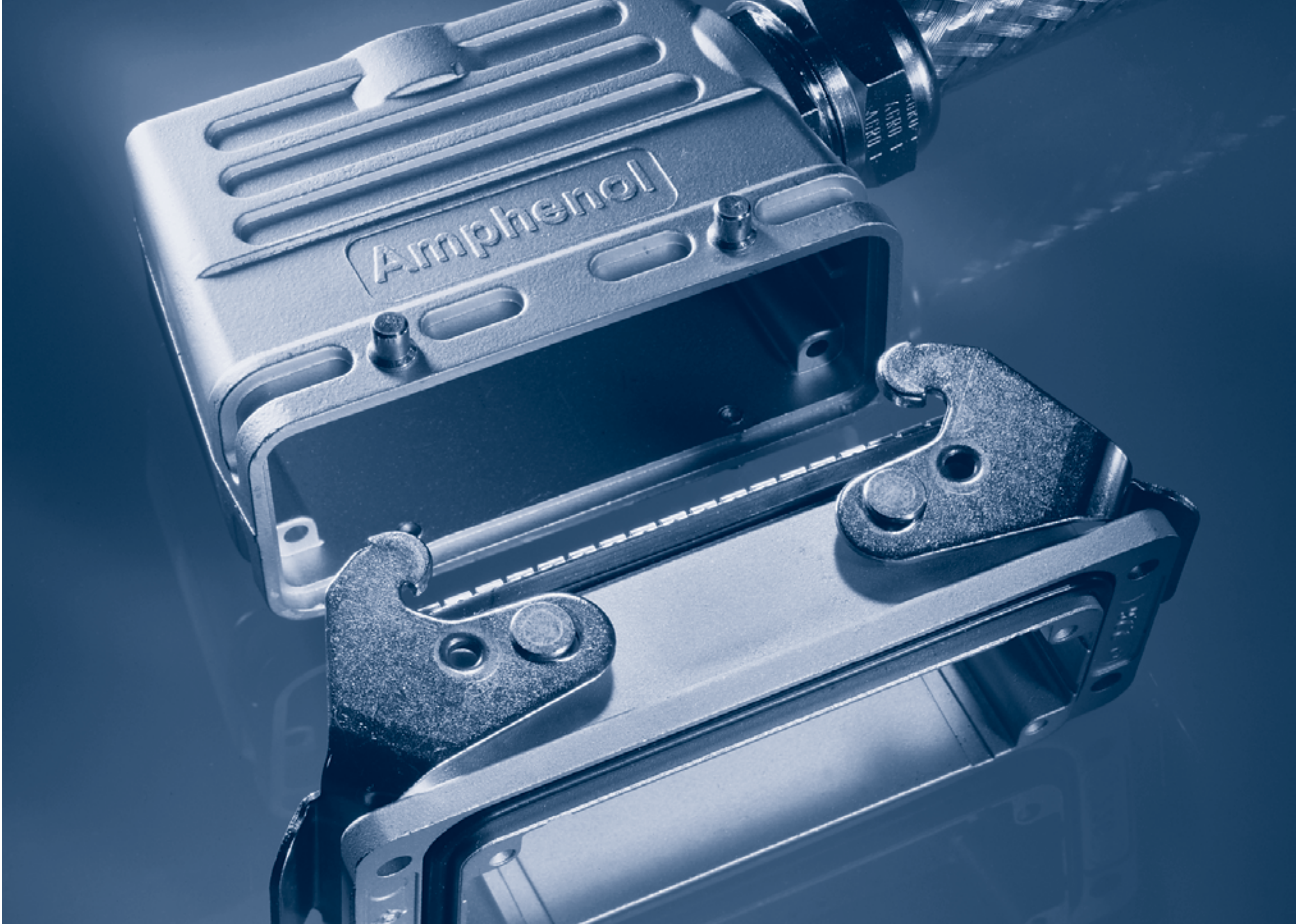

## **Für Serien**

- C 146 E 6 - 24 pol
- C 146 D 40 - 64 pol
- C 146 M 2 - 7 Module
- C 146 HSE 6 pol

## ***For series***

- *C 146 E 6 - 24 contacts*
- *C 146 D 40 - 64 contacts*
- *C 146 M 2 - 7 Module*
- *C 146 HSE 6 contacts*

EMV-Gehäuse  
EMC housings

- leitfähige Oberfläche
- Standard Verriegelungssystem
- gleiche Gehäuseabmessungen wie Standard Gehäuse
- zwei Bauhöhen
- mit und ohne Massestreifen
- hohe Dämpfungseigenschaften
- Schutzart IP 65
- Steckzyklen > 500

- *conductive surface*
- *standard locking levers*
- *same housing dimensions like standard housings*
- *two housing sizes*
- *with or without ground strap*
- *high attenuation*
- *protection class IP 65*
- *mating cycles > 500*

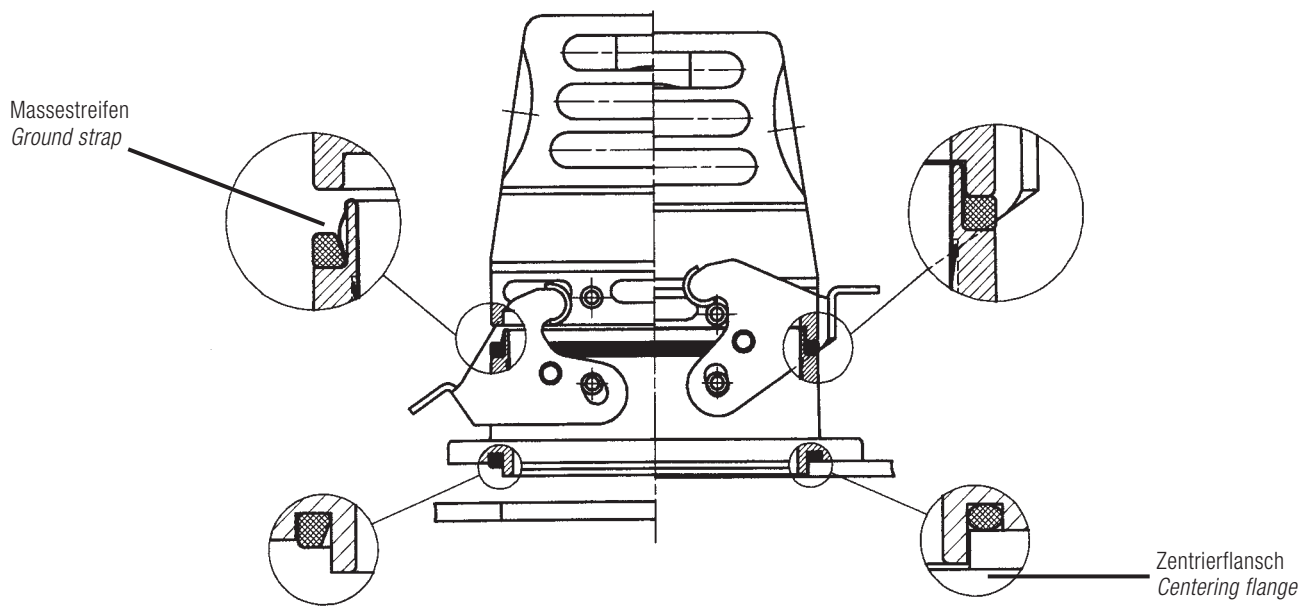

Standard Gehäuse C 146  
Standard housing C 146



Version A Standardflansch, ohne Massestreifen  
Version A Standard flange, without ground strap



Version B Standardflansch, mit Massestreifen  
Version B Standard flange, with ground strap



Version C Zentrierflansch, mit Massestreifen  
Version C Centering flange, with ground strap









C 146 E 6 pol.  
 C 146 M 2 Module  
 C 146 DD 24 pol.  
 C 146 EE 10 pol.

Gehäuse für Längsbügelverriegelung  
*Housings for 1 locking-lever-system*

EMV-Gehäuse  
*EMC housings*

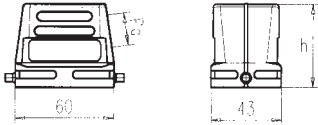
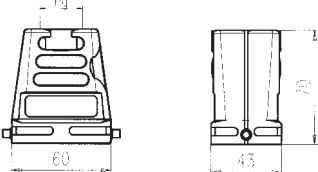
PG-Gewinde  
*PG-thread*

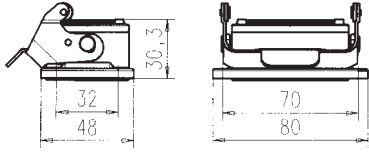
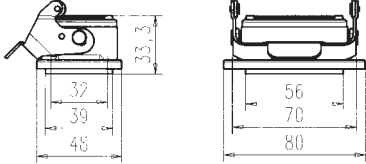
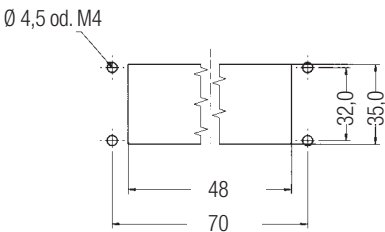
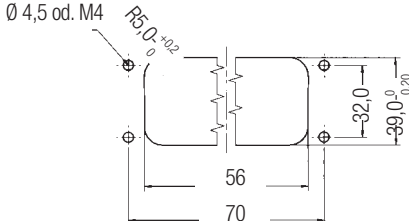
Bezeichnung - Abbildung <i>Description - Figure</i>	Maßzeichnung <i>Drawing</i>	PG	Kabelabgang <i>Cable outlet</i>	Bestell Nr. / <i>Part No.</i>	
				Niedrige Bauform <i>Low profile</i>	Hohe Bauform <i>High profile</i>
<b>Gehäuseoberteile / Hoods</b>					
Tüllengehäuse / <i>Hood</i>  	 	11	Seite / <i>side</i>	C146 11G006 556 1	
		13,5	Oben / <i>top</i>	C146 11G006 606 1	
		13,5	Seite / <i>side</i>	C146 11G006 506 1	
		16	Oben / <i>top</i>	C146 11G006 607 1	
		16	Seite / <i>side</i>	C146 11G006 507 1	
		21	Oben / <i>top</i>		C146 11G006 606 8
		21	Seite / <i>side</i>		C146 11G006 506 8
		29	Oben / <i>top</i>		C146 11G006 607 8
		29	Seite / <i>side</i>		C146 11G006 507 8
<b>Gehäuseunterteile / Housings</b>			<b>Version</b>		
Anbaugehäuse <i>Housing, bulkhead mounting</i>  	Version A + B		A	C146 11F006 901 8	
	 Version C		B	C146 11F006 902 8	
	 C		C	C146 11F006 001 8	
<b>Montageausschnitt / Panel cutout</b>					
 Version A + B		 Version C			

EMV Verschraubung für Tüllengehäuse siehe Seite 173 / EMC gland bushings for hoods see page 173





C 146 E 6 pol.  
 C 146 M 2 Module  
 C 146 DD 24 pol.  
 C 146 EE 10 pol.

EMV-Gehäuse  
 EMC housings

Gehäuse für Längsbügelverriegelung  
 Housings for 1 locking-lever-system

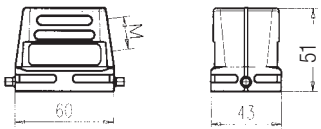
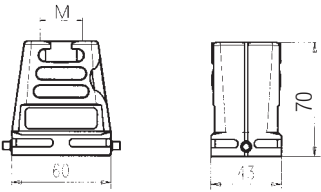
Metrisches Gewinde  
 Metric thread

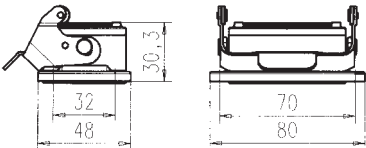
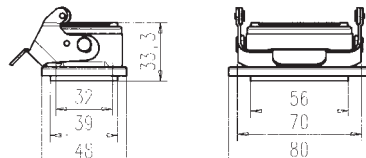
Bezeichnung - Abbildung Description - Figure	Maßzeichnung Drawing	M	Kabelabgang Cable outlet	Bestell Nr. / Part No.	
				Niedrige Bauform Low profile	Hohe Bauform High profile
<b>Gehäuseoberteile / Hoods</b>			<b>ohne Stutzen / without stud</b>		
		16	Seite / side	C146 11R006 556 1	
		20	Oben / top	C146 11R006 606 1	
		20	Seite / side	C146 11R006 506 1	
		25	Oben / top	C146 11R006 607 1	
		25	Seite / side	C146 11R006 507 1	
		25	Oben / top		C146 11R006 656 8
		25	Seite / side		C146 11R006 556 8
		32	Oben / top		C146 11R006 606 8
		32	Seite / side		C146 11R006 506 8
		<b>Gehäuseunterteile / Housings</b>			
Anbaugehäuse Housing, bulkhead mounting  	Version A + B		A	C146 11F006 901 8	
			B	C146 11F006 902 8	
	Version C		C	C146 11F006 001 8	
					





EMV Verschraubung für Tüllengehäuse siehe Seite 173 / EMC gland bushings for hoods see page 173

C 146 E 10 pol.  
 C 146 M 3 Module  
 C 146 DD 42 pol.  
 C 146 EE 18 pol.

Gehäuse für Querbügelverriegelung  
 Housings for 2 locking-lever-system

EMV-Gehäuse  
 EMC housings

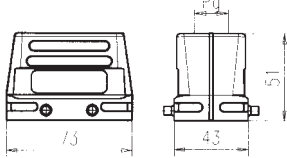
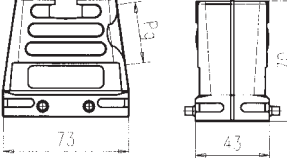
PG-Gewinde  
 PG-thread

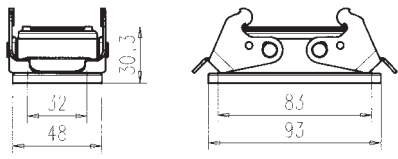
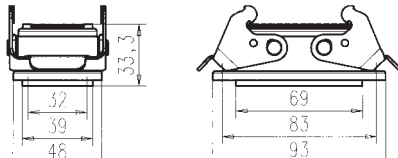
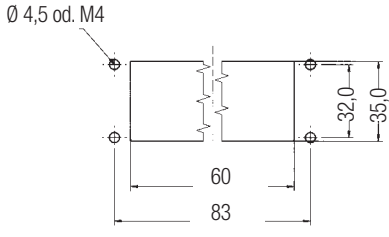
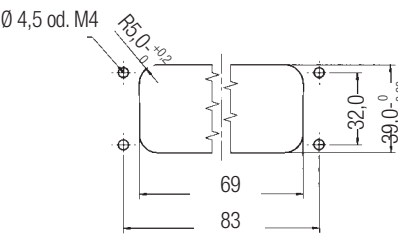
Bezeichnung - Abbildung Description - Figure	Maßzeichnung Drawing	PG	Kabelabgang Cable outlet	Bestell Nr. / Part No.	
				Niedrige Bauform Low profile	Hohe Bauform High profile
<b>Gehäuseoberteile / Hoods</b>					
Tüllengehäuse / Hood  	 	16	Oben / top	C146 11G010 600 1 C146 11G010 500 1 C146 11G010 601 1 C146 11G010 501 1	
		16	Seite / side		
21	Oben / top				
21	Seite / side				
		21	Oben / top	C146 11G010 600 8 C146 11G010 500 8 C146 11G010 601 8 C146 11G010 501 8	
		21	Seite / side		
		29	Oben / top		
		29	Seite / side		
<b>Gehäuseunterteile / Housings</b>			<b>Version</b>		
Anbaugeschäse Housing, bulkhead mounting  	Version A + B 	A		C146 11F010 901 8  C146 11F010 902 8	
		Version C 	B		
		C		C146 11F010 000 8	
<b>Montageausschnitt / Panel cutout</b>					
 					



EMV Verschraubung für Tüllengehäuse siehe Seite 173 / EMC gland bushings for hoods see page 173

C 146 E 10 pol.  
 C 146 M 3 Module  
 C 146 DD 42 pol.  
 C 146 EE 18 pol.

EMV-Gehäuse  
 EMC housings

Gehäuse für Querbügelverriegelung  
 Housings for 2 locking-lever-system

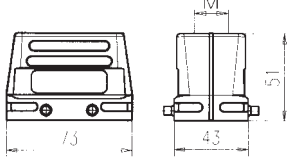
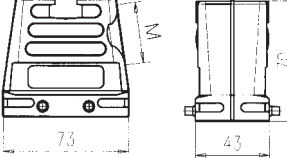
Metrisches Gewinde  
 Metric thread

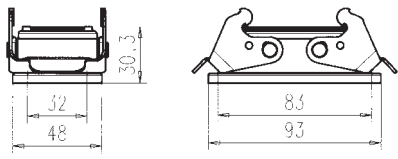
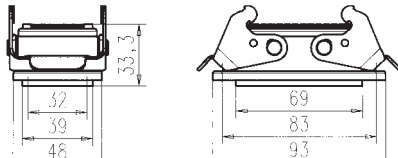
Bezeichnung - Abbildung Description - Figure	Maßzeichnung Drawing	M	Kabelabgang Cable outlet	Bestell Nr. / Part No.	
				Niedrige Bauform Low profile	Hohe Bauform High profile
<b>Gehäuseoberteile / Hoods</b>				<b>ohne Stutzen / without stud</b>	
Tüllengehäuse / Hood  		20	Oben / top	C146 11R010 650 1	
		20	Seite / side	C146 11R010 550 1	
		25	Oben / top	C146 11R010 600 1	
		25	Seite / side	C146 11R010 500 1	
		32	Oben / top	C146 11R010 601 1	
		25	Oben / top		C146 11R010 650 8
		25	Seite / side		C146 11R010 550 8
		32	Oben / top		C146 11R010 600 8
		32	Seite / side		C146 11R010 500 8
		40	Oben / top		C146 11R010 601 8
<b>Gehäuseunterteile / Housings</b>			<b>Version</b>		
Anbaugehäuse Housing, bulkhead mounting  	Version A + B		A	C146 11F010 901 8	
			B	C146 11F010 902 8	
			Version C		C
					







EMV Verschraubung für Tüllengehäuse siehe Seite 173 / EMC gland bushings for hoods see page 173

C 146 E 16 pol.  
 C 146 M 5 Module  
 C 146 D 40 pol.  
 C 146 DD 72 pol.  
 C 146 HSE 6 pol.  
 C 146 EE 32 pol.

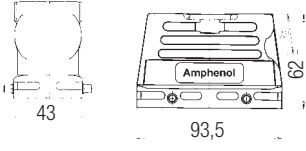
EMV-Gehäuse  
 EMC housings

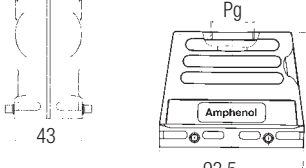
Gehäuse für Querbügelverriegelung  
 Housings for 2 locking-lever-system

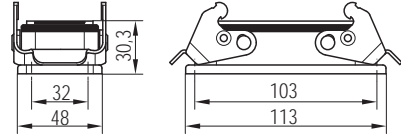
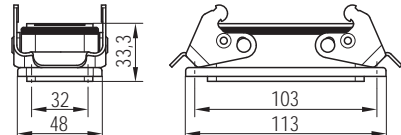
PG-Gewinde  
 PG-thread

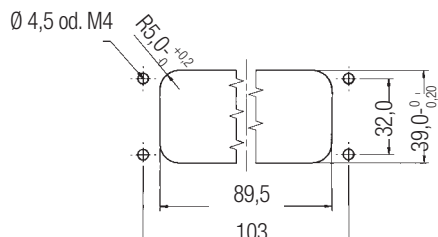
Bezeichnung - Abbildung Description - Figure	Maßzeichnung Drawing	PG	Kabelabgang Cable outlet	Bestell Nr. / Part No.	
				Niedrige Bauform Low profile	Hohe Bauform High profile
<b>Gehäuseoberteile / Hoods</b>					
Tüllengehäuse / Hood 		21	Oben / top	C146 11G016 600 1 C146 11G016 500 1 C146 11G016 601 1 C146 11G016 501 1	
		21	Seite / side		
		29	Oben / top		
		29	Seite / side		
<b>Gehäuseunterteile / Housings</b>					
Anbaugehäuse Housing, bulkhead mounting 	Version A + B 	A		C146 11F016 901 8  C146 11F016 902 8	
	Version C 	C			
<b>Montageausschnitt / Panel cutout</b>					
					
Version A + B		Version C			





EMV Verschraubung für Tüllengehäuse siehe Seite 173 / EMC gland bushings for hoods see page 173

C 146 E 16 pol.  
 C 146 M 5 Module  
 C 146 D 40 pol.  
 C 146 DD 72 pol.  
 C 146 HSE 6 pol.  
 C 146 EE 32 pol.

EMV-Gehäuse  
 EMC housings

Gehäuse für Querbügelverriegelung  
 Housings for 2 locking-lever-system

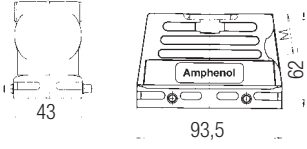
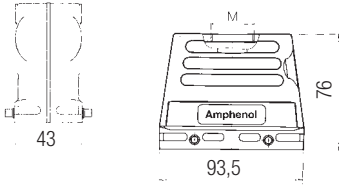
Metrisches Gewinde  
 Metric thread

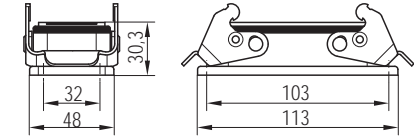
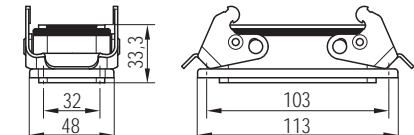
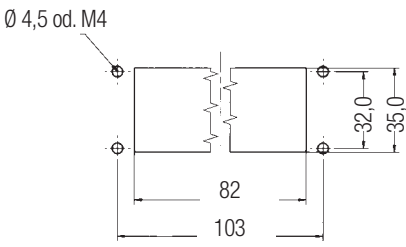
Bezeichnung - Abbildung Description - Figure	Maßzeichnung Drawing	M	Kabelabgang Cable outlet	Bestell Nr. / Part No.	
				Niedrige Bauform Low profile	Hohe Bauform High profile
<b>Gehäuseoberteile / Hoods</b>					
Tüllengehäuse / Hood 		25	Oben / top	C146 11R016 650 1 C146 11R016 550 1 C146 11R016 600 1 C146 11R016 500 1	
		25	Seite / side		
		32	Oben / top		
		32	Seite / side		
		25	Oben / top	C146 11R016 650 8 C146 11R016 550 8 C146 11R016 600 8 C146 11R016 500 8 C146 11R016 601 8 C146 11R016 501 8	
		25	Seite / side		
		32	Oben / top		
		32	Seite / side		
		40	Oben / top		
		40	Seite / side		
<b>Gehäuseunterteile / Housings</b>			<b>Version</b>		
Anbaugehäuse Housing, bulkhead mounting 	Version A + B 	A	C146 11F016 901 8		
	Version C 	B	C146 11F016 902 8		
		C	C146 11F016 000 8		
<b>Montageausschnitt / Panel cutout</b>					
					
Version A + B		Version C			







EMV Verschraubung für Tüllengehäuse siehe Seite 173 / EMC gland bushings for hoods see page 173

C 146 E 24 pol.  
 C 146 M 7 Module  
 C 146 D 64 pol.  
 C 146 DD 108 pol.  
 C 146 EE 46 pol.

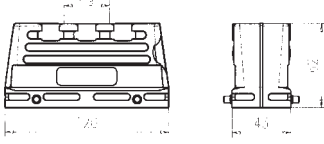
EMV-Gehäuse  
 EMC housings

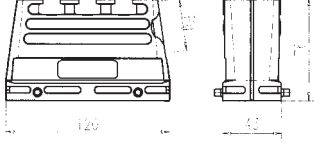
Gehäuse für Querbügelverriegelung  
 Housings for 2 locking-lever systems

PG-Gewinde  
 PG-thread

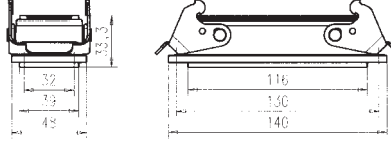
Bezeichnung - Abbildung Description - Figure	Maßzeichnung Drawing	PG	Kabelabgang Cable outlet	Bestell Nr. / Part No.	
				Niedrige Bauform Low profile	Hohe Bauform High profile
<b>Gehäuseoberteile / Hoods</b>					
Tüllengehäuse / Hood   	  	21	Oben / top	C146 11G024 600 1	
		21	Seite / side	C146 11G024 500 1	
		29	Oben / top	C146 11G024 601 1	
		29	Seite / side	C146 11G024 501 1	
		21	Oben / top		C146 11G024 600 8
		21	Seite / side		C146 11G024 500 8
		29	Oben / top		C146 11G024 601 8
		29	Seite / side		C146 11G024 501 8
<b>Gehäuseunterteile / Housings</b>			<b>Version</b>		
Anbaugehäuse Housing, bulkhead mounting   	Version A + B	A	C146 11F024 901 8		
	Version C	B	C146 11F024 902 8		
		C	C146 11F024 000 8		
<b>Montageausschnitt / Panel cutout</b>					
 <p>Version A + B</p>		 <p>Version C</p>			

EMV Verschraubung für Tüllengehäuse siehe Seite 173 / EMC gland bushings for hoods see page 173







C 146 E 24 pol.  
 C 146 M 7 Module  
 C 146 D 64 pol.  
 C 146 DD 108 pol.  
 C 146 EE 46 pol.

EMV-Gehäuse  
 EMC housings

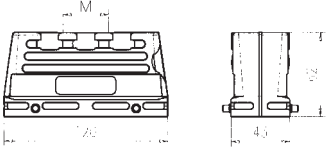
Gehäuse für Querbügelverriegelung  
 Housings for 2 locking-lever systems

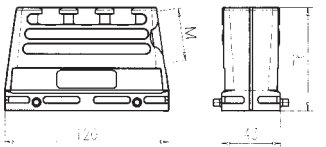
Metrisches Gewinde  
 Metric thread

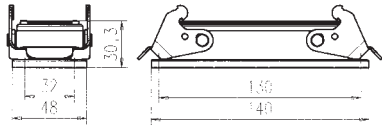
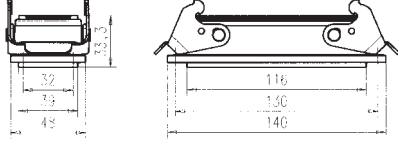
Bezeichnung - Abbildung Description - Figure	Maßzeichnung Drawing	M	Kabelabgang Cable outlet	Bestell Nr. / Part No.	
				Niedrige Bauform Low profile	Hohe Bauform High profile
<b>Gehäuseoberteile / Hoods</b>					
Tüllengehäuse / Hood 		25	Oben / top	C146 11R024 650 1	
		25	Seite / side	C146 11R024 550 1	
		32	Oben / top	C146 11R024 600 1	
		32	Seite / side	C146 11R024 500 1	
		25	Oben / top		C146 11R024 650 8
		25	Seite / side		C146 11R024 550 8
		32	Oben / top		C146 11R024 600 8
		32	Seite / side		C146 11R024 500 8
40	Oben / top		C146 11R024 601 8		
40	Seite / side		C146 11R024 501 8		
<b>Gehäuseunterteile / Housings</b>			<b>Version</b>		
Anbaugehäuse Housing, bulkhead mounting 	Version A + B 	A		C146 11F024 901 8	
	Version C 	B		C146 11F024 902 8	
C			C146 11F024 000 8		

EMV Verschraubung für Tüllengehäuse siehe Seite 173 / EMC gland bushings for hoods see page 173



# C 146 Zubehör / Accessories





## Übersicht





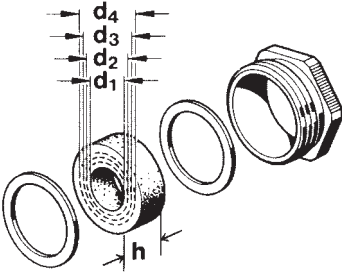

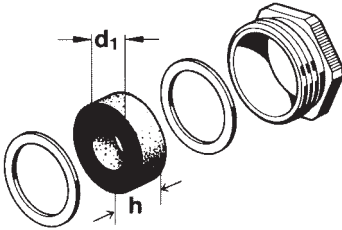

- Verschraubungen
- EMV Verschraubungen
- Verschraubungen mit Zugentlastung
- Codierbolzen
- Führungsstifte / Buchsen
- D-Sub Adapterplatten
- Moosgummidichtungen
- Klebeschild nach CSA-Vorschrift

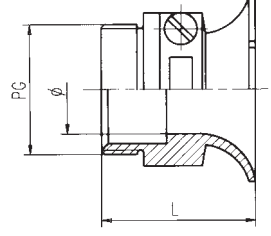
## Overview

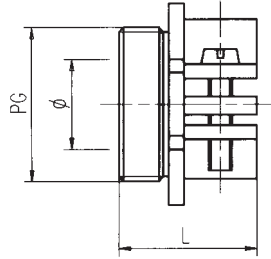
- gland bushings
- EMC gland bushings
- Cable seals with cable clamp
- Key pin
- Guide pin / bush
- D-Sub adaptors
- Foam rubber sealing
- Label for CSA regulation

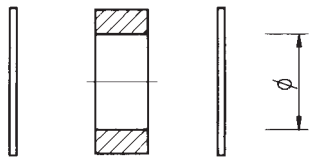
Bezeichnung - Abbildung Description - Figure	Zeichnung Drawing	PG PG	M M	Stückzahl Pieces	Bestell Nr. Part No.
Metall, mit ausschneidbaren Dichtungen (Zwiebelringen) Metal, with variable inner diameter  		11	-	10	VN16 110 0014 X (Thermoplast)
		-	20	10	VN16 200 0114 X (Thermoplast)
		13,5	-	10	VN16 135 0014 X
		16	-	10	VN16 160 0014 X
		-	20	10	VN16 200 0114 X
		21	-	10	VN16 210 0014 X
		-	25	10	VN16 250 0114 X
		29	-	10	VN16 290 0014 X
		-	32	10	VN16 320 0114 X
		36	-	10	VN16 360 0014 X
		-	40	10	VN16 400 0114 X
		42	-	10	VN16 420 0014 X
-	50	10	VN16 500 0114 X		
Metall, mit Standard Dichtung Metal, with standard diameter  		11	-	10	VN16 110 0013 X (Thermoplast)
		13,5	-	10	VN16 135 0013 X
		16	-	10	VN16 160 0013 X
		21	-	10	VN16 210 0013 X
		29	-	10	VN16 290 0013 X
		36	-	10	VN16 360 0013 X
		42	-	10	VN16 420 0013 X

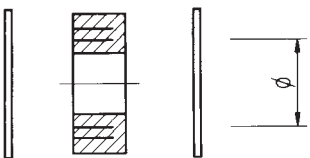
<sup>1)</sup> Achtung: nicht für Gehäuse ohne Stützen geeignet / Attention: not usable for hoods without stud

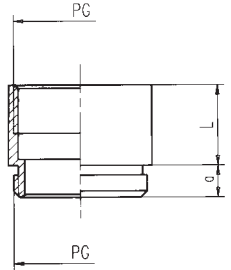
Bezeichnung - Abbildung Description - Figure	Zeichnung Drawing	PG PG	M M	Stückzahl Pieces	Bestell Nr. Part No.
Kabelverschraubung ohne Dichtung Cable clamp without gasket  		11	-	5	VN16 110 0004 V (Thermoplast)
		13,5	-	5	VN16 135 0002 V
		- 16	-	5	VN16 160 0102 V
		16	-	5	VN16 160 0002 V
		- 20	-	5	VN16 200 0102 V
		21	-	5	VN16 210 0002 V
		- 25	-	5	VN16 250 0102 V
		29	-	5	VN16 290 0002 V
- 32	-	5	VN16 320 0102 V		
Kabelverschraubung ohne Dichtung Cable clamp without gasket  		13,5	-	5	VN16 135 0003 V
		16	-	5	VN16 160 0003 V
		- 20	-	5	VN16 200 0103 V
		21	-	5	VN16 210 0003 V
		- 25	-	5	VN16 250 0103 V
		29	-	5	VN16 290 0003 V
- 32	-	5	VN16 320 0103 V		
Dichtung, Druckscheibe Sealing, pressure disk  		11	-	10	VN16 110 0028 X
		13,5	-	10	VN16 135 0028 X
		16	-	10	VN16 160 0028 X
		21	-	10	VN16 210 0028 X
Ausschneidbare Dichtung, Druckscheibe Sealing with variable inner diameter, and pressure rings  		29	-	10	VN16 290 0028 X
		11	-	10	VN16 110 0029 X
		13,5	-	10	VN16 135 0029 X
		16	-	10	VN16 160 0029 X
Zwischenstutzen Stud  		21	-	10	VN16 210 0029 X
		29	-	10	VN16 290 0029 X
		11	-	1	N16 011 0010
		13,5	-	1	N16 013 0010
		16	-	1	N16 016 0010
21	-	1	N16 021 0010		
29	-	1	N16 029 0010		

<sup>1)</sup> Achtung: nicht für Gehäuse ohne Stutzen geeignet / Attention: not usable for hoods without stud

Bezeichnung - Abbildung Description - Figure	Klemmbereich Ø Clamping range Ø	A mm	PG PG	M M	Stückzahl Pieces	Bestell Nr. / Part No.
	4 - 10 mm	24,4	<b>11</b>	-	10	VN16 110 0027 X
	4 - 10 mm	20	-	<b>16</b>	10	VN16 160 0127 X
	5 - 12 mm	26,5	<b>13,5</b>	-	10	VN16 135 0027 X
	6 - 12 mm	24	-	<b>20</b>	10	VN16 200 0127 X
	9 - 14 mm	29,5	<b>16</b>	-	10	VN16 160 0027 X
	9 - 16 mm	28	-	<b>25</b>	10	VN16 250 0127 X
	13 - 18 mm	36,2	<b>21</b>	-	10	VN16 210 0027 X
	10 - 21 mm	36	-	<b>32</b>	10	VN16 320 0127 X
	14 - 25 mm	43,6	<b>29</b>	-	10	VN16 290 0027 X
	16 - 28 mm	46	-	<b>40</b>	10	VN16 400 0127 X

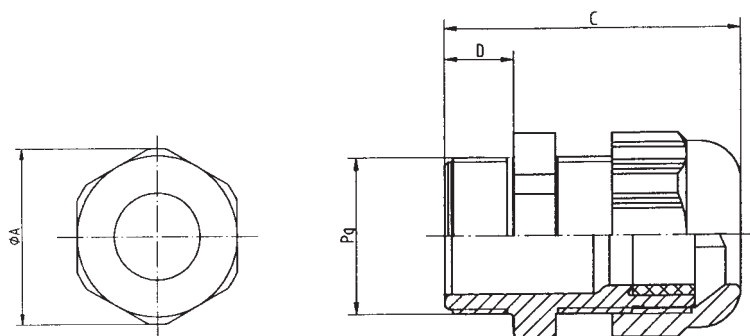

Blindstopfen aus Messing vernickelt mit Einstich und O-Ring Plugs brass nickel-plated with recess and o-ring		<b>M 20</b>	10	VN16 020 0113 (1) X
		<b>M 25</b>	10	VN16 025 0113 (1) X
		<b>M 32</b>	10	VN16 032 0113 (1) X
		<b>M 40</b>	10	VN16 040 0113 (1) X



**EMV Verschraubung IP 68 (Material CuZn / PA / - 30 °C + 120 °C)**  
**EMC gland bushings IP 68 (Material CuZn / PA / - 30 °C + 120 °C)**

Bezeichnung - Abbildung Description - Figure	Klemmbereich F Clamping range F	PG PG	M M	Stückzahl Pieces	Bestell Nr. Part No.
Kabelverschraubung EMV Gland bushing EMC  	4 - 10 mm	<b>11</b>	–	10	VN16 110 0026 X
	5,5 - 10 mm	–	<b>16</b>	10	VN16 160 0126 X
	5 - 12 mm	<b>13,5</b>	–	10	VN16 135 0026 X
	8 - 13 mm	–	<b>20</b>	10	VN16 200 0126 X
	8 - 14 mm	<b>16</b>	–	10	VN16 160 0026 X
	11 - 18 mm	–	<b>25</b>	10	VN16 250 0126 X
	11 - 17,5 mm	<b>21</b>	–	10	VN16 210 0026 X
	15 - 21 mm	–	<b>32</b>	10	VN16 320 0126 X
	16 - 25 mm	<b>29</b>	–	10	VN16 290 0026 X
19 - 27 mm	–	<b>40</b>	10	VN16 400 0126 X	

**Montagehinweise für metrische Verschraubung / Assembly instructions for metric clamp**

- Der Außenmantel des Kabels wird entfernt bis Unterseite Lamellen-Klemmkäfig, das Drahtgeflecht wird erst ein Stück weiter unten abgeschnitten und dann als ringförmiger Wulst ausgebildet. Der innere Schutzmantel kann am Kabel dranbleiben, sofern er durch die untere Öffnung der Verschraubung passt.
- Bei der Montage, beim Zusammenschrauben der Kabelverschraubung wird der ringförmige Wulst durch die Lamellentülle auf den Boden des Unterteils verpresst und findet in einer Auskoffnung Platz. Dadurch wird die EMV-Sicherheit hergestellt.
- *The cable jacket should be removed as far as the underside of the cable clamping; the wire netting is then to be cut down a little further and subsequently must be formed into a circular rim. The protective jacket can remain attached to the cable provided that it passes through the lower opening of the clamp.*
- *On assembly, while screwing the cable clamp, the circular rim has to be pushed through and pressed on the fins commutator on the base of the underside and settle into a depression. By doing this the EMC security will remain.*

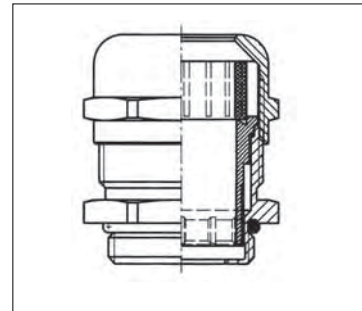

**Montagehinweise für PG-Verschraubung / Assembly instructions for PG-Clamp**



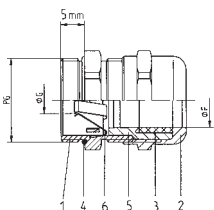
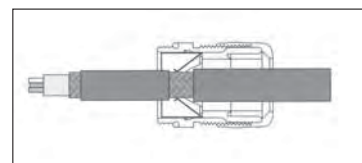
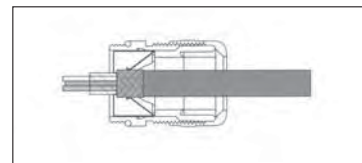
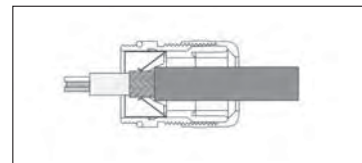



- Außenmantel und Schirm absetzen
- Außenmantel nach ca. 15 mm mit Rundschnitt versehen, jedoch nicht abziehen
- Leitung durch die Verschraubung führen
- Außenmantel abziehen
- Leitung zurückziehen bis die Verbindung zwischen Leitungsschirm und Kontaktfeder hergestellt ist
- *Cut and remove cable jacket and braid*
- *Cut cable jacket appr. 15 mm further but don't remove it yet*
- *Insert cable through backshell*
- *Remove now the cut jacket part*
- *Pull back cable until connection is made between grounding fingers and braid*
- Außenmantel absetzen
- Schirmgeflecht ca. 15 - 20 mm über den Außenmantel zurückschlagen
- Leitungen in Verschraubung einführen, bis Verbindung zwischen Leitungsschirm und Kontaktfeder hergestellt ist
- *Cut and remove cable jacket*
- *Fold braid appr. 15 to 20 mm back over jacket*
- *Insert cable into backshell until grounding fingers connect with braid*
- Schirmgeflecht ca. 10 mm freilegen
- Leitung durch die Verschraubung führen bis Verbindung zwischen Leitungsschirm und Kontaktfeder hergestellt ist
- *Expose braid appr. 10 mm*
- *Insert cable through backshell until grounding fingers rest on braid*

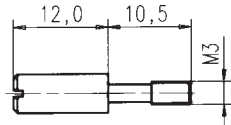

- |                     |                      |
|---------------------|----------------------|
| 1 = Zwischenstutzen | 1 = Screwed gland    |
| 2 = Hutmutter       | 2 = Cap nut          |
| 3 = Dichtung        | 3 = Sealing          |
| 4 = O-Ringe         | 4 = O ring           |
| 5 = Einsatz         | 5 = Insert           |
| 6 = Erdungsfinger   | 6 = Grounding finger |

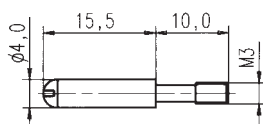

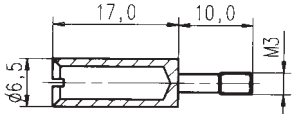
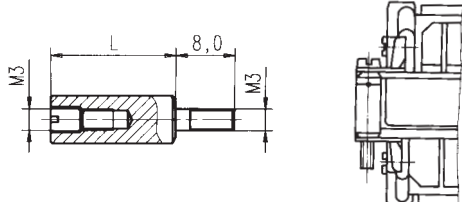

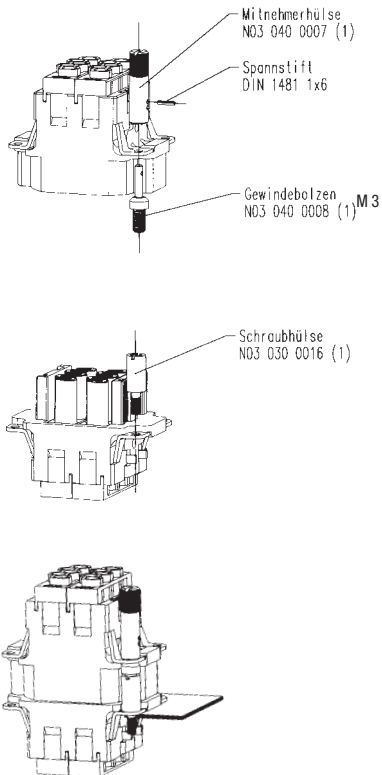

# C 146

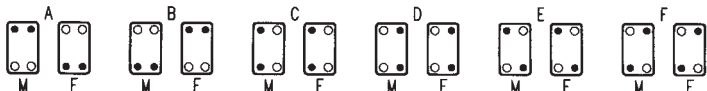
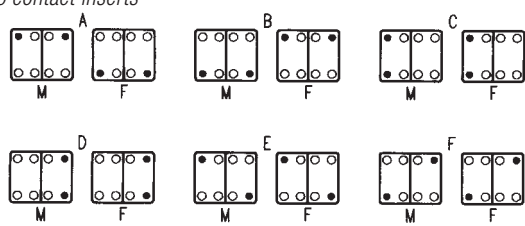
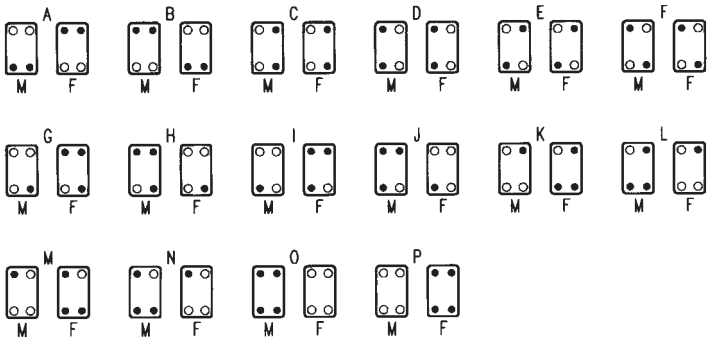
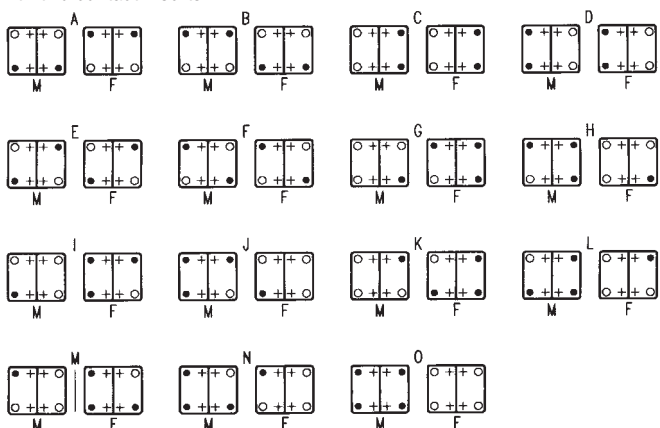

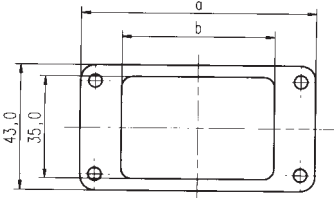

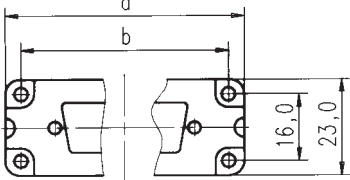
## Zubehör Accessories

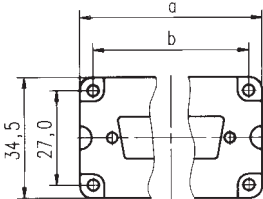
Bezeichnung - Abbildung Description - Figure	Zeichnung Drawing	Stückzahl Pieces	Bestell Nr. Part No.
Kodierbolzen mit Sicherungsscheibe Key pin with lock washer 		10 100	VN17 050 0004 (1) VN17 050 0004 (101)
Führungsstift Guide pin 		10	VN13 040 0009 (1) X
Führungsbuchse Guide socket 		10	VN13 040 0008 (1) X
Verriegelungsschraube für Kontakteinsätze Locking screw for contact inserts C146 D 15, 25 C146 A 10, 16		L 23	VN03 030 0021
Verriegelungsschraube für Kontakteinsätze Locking screw for contact inserts C146 E; M; D 40, 64; H		20	VN03 030 0020
Verriegelungsset Locking set C146 E; M; D 40, 64; H 		10	VN03 030 3000 X

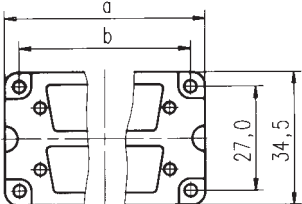
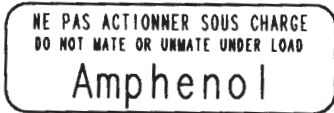
Kodierschema  
Polarization system

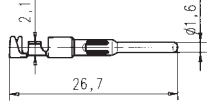
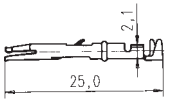
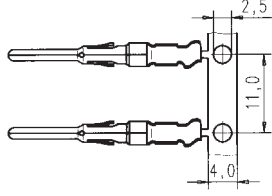
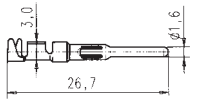
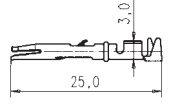
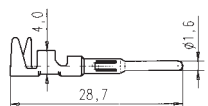
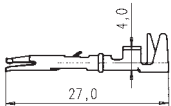
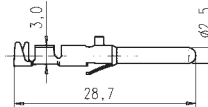
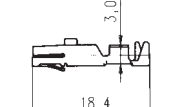
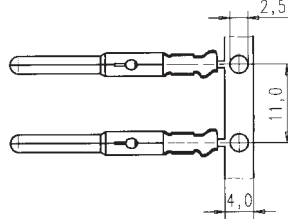
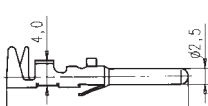
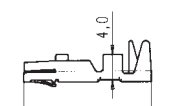
Bezeichnung Description	
<p>Kodierschema mit Kodierbolzen <i>Polarization system with key pin</i></p>	<p>Für Gehäuse mit einem Kontakteinsatz <i>For housings with one contact insert</i></p>  <p>Für Gehäuse mit zwei Kontakteinsätzen <i>For housings with two contact inserts</i></p>  <ul style="list-style-type: none"> <li>● Kodierbolzen</li> <li>○ Befestigungsschrauben</li> <li>M - Stifteinsatz</li> <li>F - Buchseneinsatz</li> </ul> <ul style="list-style-type: none"> <li>● Key pin</li> <li>○ Locking screw</li> <li>M - Male insert</li> <li>F - Female insert</li> </ul>
<p>Kodierschema mit Führungsstift und Führungsbuchse <i>Polarization system with guide pin and guide socket</i></p>	<p>Für Gehäuse mit einem Kontakteinsatz <i>For housings with one contact insert</i></p>  <p>Für Gehäuse mit zwei Kontakteinsätzen <i>For housings with two contact inserts</i></p>  <ul style="list-style-type: none"> <li>● Führungsstift</li> <li>○ Führungsbuchse</li> <li>+ Befestigungsschrauben</li> <li>M - Stifteinsatz</li> <li>F - Buchseneinsatz</li> </ul> <ul style="list-style-type: none"> <li>● Guide pin</li> <li>○ Guide socket</li> <li>+ Locking screw</li> <li>M - Male insert</li> <li>F - Female insert</li> </ul>

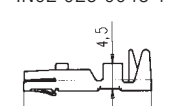
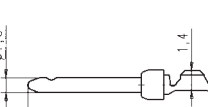
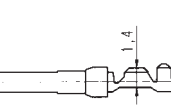
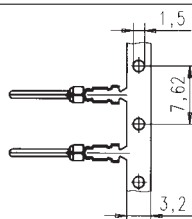
Bezeichnung - Abbildung Description - Figure	Zeichnung Drawing	Größe Size			Bestell Nr. Part No.
Moosgummidichtung 2 mm Foam rubber sealing 2 mm  		a 80	b 70	6	N06 080 0003 1
		93	83	10	N06 080 0003 2
		113	103	16	N06 080 0003 3
		140	130	24	N06 080 0003 4
Adapterplatte D-Sub Set Metall Adaptor for D-Sub Set metal  	 <p data-bbox="464 1122 639 1200">2 x Platte / adaptor 4 x M3 x 6,5 8 x M3 x 14</p>	a 57	b 49,5	D-Sub 15	15  C146 N32 015 G2
		57	49,5	25	25  C146 N32 025 G2
Adapterplatte D-Sub Set einreihig Adaptor for D-Sub set single-row  	 <p data-bbox="464 1507 639 1585">2 x Platte / adaptor 4 x M3 x 6,5 8 x M3 x 14</p>	a 51,5	b 44	D-Sub 9	6  C146 N32 009 G1
		51,5	44	15	6  C146 N32 015 G1
		64,5	57	25	10  C146 N32 025 G1
		85	77,5	37	16  C146 N32 037 G1
		85	77,5	50	16  C146 N32 050 G1
Adapterplatte D-Sub Set zweireihig Adaptor for D-Sub set double-row  	 <p data-bbox="464 1877 639 1955">2 x Platte / adaptor 4 x M3 x 6,5 8 x M3 x 14</p>	a 51,5	b 44	D-Sub 9	6  C146 N33 009 G1
		51,5	44	15	6  C146 N33 015 G1
		64,5	57	25	10  C146 N33 025 G1
		85	77,5	37	16  C146 N33 037 G1
		85	77,5	50	16  C146 N33 050 G1
Hinweisschild für CSA-Anwendung Label for CSA application				50 Stück Pieces	N07 045 0001 L

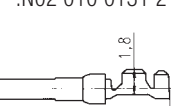
Serie Series	Maßzeichnung Einzelkontakt Drawing single contact		Maßzeichnung Bandkontakt Drawing contacts on reel
C146 D, M	.N01 016 0003 1 	.N02 016 0003 1 	
	.N01 016 0002 1 .N01 016 0015 1 <sup>1)</sup> 	.N02 016 0002 1 .N02 016 0015 1 <sup>1)</sup> 	
	.N01 016 0005 1 .N01 016 0016 1 <sup>1)</sup> 	.N02 016 0005 1 .N02 016 0016 1 <sup>1)</sup> 	
C146 E, M	.N01 025 0001 1 	.N02 025 0001 1 	
	.N01 025 0010 1 	.N02 025 0010 1 	
	.N01 025 0043 1 	.N02 025 0043 1 	
C146 M	.N01 010 0130 2 	.N02 010 0130 2 	
	.N01 010 0131 2 	.N02 010 0131 2 	

<sup>1)</sup> gekennzeichnet mit „H“ / marked with „H“

Serie Series	Maßzeichnung Drawing	Querschnitt Wire gauge	A	B	Stückzahl Pieces	Bestell Nr. Part No.
C146 D, DD, M	.N01 016 002X 	0,14 - 0,37	0,9	2,6	100	VN01 016 0024 (1)C
		0,5	1,1	2,6	100	VN01 016 0025 (1)C
		0,75 - 1,0	1,45	2,6	100	VN01 016 0026 (1)C
		1,5	1,75	3,0	100	VN01 016 0027 (1)C
		2,5	2,25	3,2	100	VN01 016 0028 (1)C
	.N02 016 002X 	0,14 - 0,37	0,9	2,6	100	VN02 016 0024 (1)C
		0,5	1,1	2,6	100	VN02 016 0025 (1)C
		0,75 - 1,0	1,45	2,6	100	VN02 016 0026 (1)C
		1,5	1,75	3,0	100	VN02 016 0027 (1)C
		2,5	2,25	3,2	100	VN02 016 0028 (1)C
C146 E, EE	.N01 025 003X 	0,5	1,1	2,6	100	VN01 025 0035 (1)C
		0,75 - 1,0	1,45	2,6	100	VN01 025 0036 (1)C
		1,5	1,75	3,0	100	VN01 025 0037 (1)C
		2,5	2,3	3,2	100	VN01 025 0038 (1)C
		4,0	2,9	4,0	100	VN01 025 0039 (1)C
	.N02 025 003X 	0,5	1,1	2,6	100	VN02 025 0035 (1)C
		0,75 - 1,0	1,45	2,6	100	VN02 025 0036 (1)C
		1,5	1,75	3,0	100	VN02 025 0037 (1)C
		2,5	2,3	3,2	100	VN02 025 0038 (1)C
		4,0	2,9	4,0	100	VN02 025 0039 (1)C
C146 M	.N01 025 00XX 	0,5	1,1	2,6	100	VN01 025 0029 (1)C
		0,75 - 1,0	1,45	2,6	100	VN01 025 0030 (1)C
		1,5	1,75	3,0	100	VN01 025 0031 (1)C
		2,5	2,25	3,45	100	VN01 025 0032 (1)C
		4,0	2,85	3,9	100	VN01 025 0033 (1)C
	.N02 025 00XX 	0,5	1,1	2,6	100	VN02 025 0029 (1)C
		0,75 - 1,0	1,45	2,6	100	VN02 025 0030 (1)C
		1,5	1,75	3,0	100	VN02 025 0031 (1)C
		2,5	2,25	3,45	100	VN02 025 0032 (1)C
		4,0	2,85	3,9	100	VN02 025 0033 (1)C
	.N01 036 000X 	1,5	1,75	3,0	100	VN01 036 0004 (1)C
		2,5	2,25	3,45	100	VN01 036 0005 (1)C
		4,0	2,85	3,9	100	VN01 036 0001 (1)C
		6,0	3,55	4,9	100	VN01 036 0002 (1)C
		10,0	4,4	5,9	100	VN01 036 0003 (1)C
	.N02 036 000X 	1,5	1,75	3,0	100	VN02 036 0004 (1)C
		2,5	2,25	3,45	100	VN02 036 0005 (1)C
		4,0	2,85	3,9	100	VN02 036 0001 (1)C
6,0		3,55	4,9	100	VN02 036 0002 (1)C	
10,0		4,4	5,9	100	VN02 036 0003 (1)C	

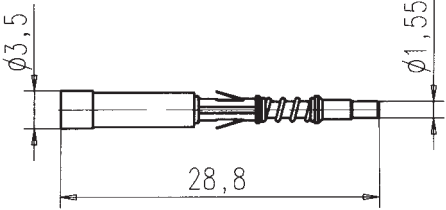
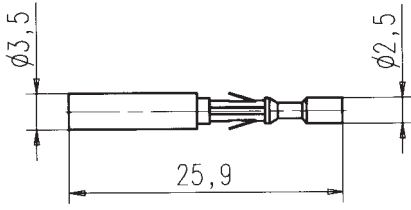
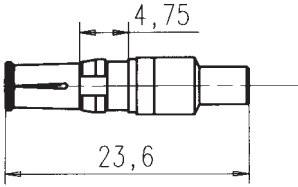
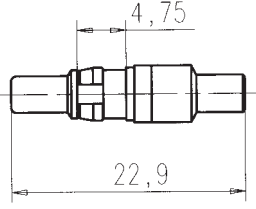
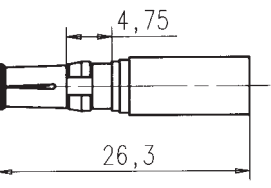
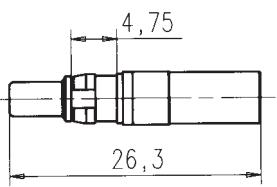
Serie Series	Maßzeichnung Einzelkontakt Drawing single contact	Bestell Nr. Part No.
C146 M LWL C146 M FO		N01 016 0040 8
		N02 016 0040 8
C146 M Koax C146 M Coax		17 DM 537 421
		17 DM 537 401
		17 DM 537 425
		17 DM 537 405







Ausführung Style	gekapselt enclosed	ungekapselt unenclosed	Schutzleiter protective earthing contact	Zugentastung cable clamp	Fingersicherheit gesteckt finger safety mated	Fingersicherheit ungesteckt finger safety unmated	Handrücken- sicherheit gesteckt hand back safety mated	Steckverbinder mit Schaltleistung <sup>1)</sup> Connector with breaking capacity <sup>1)</sup>	Wiederanschießbar rewirable	Zugentlastung Cable clamp	
										mit <sup>2)</sup> with	ohne <sup>3)</sup> without
Tüllengehäuse mit Stifteinsatz  <i>Hood with pin insert</i>	X		X		X		X	X	X	X	X
Stifteinsatz  <i>Pin insert</i>		X	X					X	X	4)	X
Tüllengehäuse mit Buchseinsatz  <i>Hood with socket insert</i>	X		X		X	X	X	X	X	X	X
Buchseinsatz  <i>socket insert</i>		X	X					X	X	4)	X
Kupplungsgehäuse mit Stifteinsatz  <i>Coupling housing with pin insert</i>	X		X		X			X	X	X	X
Kupplungsgehäuse mit Buchseinsatz  <i>Coupling housing with socket insert</i>	X		X		X	X	X	X	X	X	X
Anbau-Sockelgehäuse mit Stifteinsatz  <i>Housing with pin insert</i>	X		X		X		X	X	X	X	X
Anbau-Sockelgehäuse mit Buchseinsatz  <i>Housing with socket insert</i>	X		X		X	X	X	X	X	X	X

<sup>1)</sup> Bei Verwendung als Steckverbinder mit Schaltleistung ist der Strom zu begrenzen / When used as connector with braking capacity the load shall be reduced

<sup>2)</sup> Bei Verwendung von Kabelverschraubungen (siehe Seite 169) / When using cable seals (see page 169)

<sup>3)</sup> Bei Standard Verschraubung / When using standard gland bushings

<sup>4)</sup> siehe Einzelangaben / see detail information

**Sofern nicht anders angegeben, sind zur Sicherstellung der Schutzleiterfunktion die Kontakteinsätze in metallisch leitende Gehäuse einzubauen, bzw. auf Schienen oder Montageplatten zu montieren.**

**If not otherwise stated the contact inserts have to be mounted in metallic conductive housings resp. on bars or mounting boards to complete the protective earth grounding.**

### ! Allgemeine technische Informationen

Hinweise:

- Die Sicherheit von Steckverbindern/Steckverbinder mit Schaltleistung (Steckvorrichtung) ist abhängig von der richtigen Auswahl der Produkte, dem ordnungsgemäßen Einbau und der sachgemäßen Montage.
- Verbindlich für den Einsatz von Steckverbindern sind die jeweiligen Anforderungen der Gerätevorschriften. Dies gilt insbesondere für die Festlegung der Bemessungsspannung und der damit zusammenhängenden Luft- und Kriechstrecken.
- Alle Angaben der Bemessungsdaten der in diesem Katalog aufgeführten Steckverbindern sind auf die Überspannungskategorie III sowie den Verschmutzungsgrad 3 (Anwendung im Maschinenbau) bezogen.
- Alle technischen Angaben beziehen sich auf Steckverbinder, also Betriebsmittel, die bei bestimmungsgemäßer Verwendung (unter elektrischer Spannung) nicht gesteckt oder getrennt werden dürfen. Soweit Steckverbinder im Sinne von Steckvorrichtungen (Steckverbinder mit Schaltleistung) verwendet werden, ist dies in der Kurzinformation der betreffenden Abschnitte aufgeführt.
- Der Berührungsschutz der Kontakteinsätze im Anschlussbereich ist durch den Einbau sicherzustellen.
- Beim Einbau der Steckverbinder in nicht leitende Gehäuse sind beide Schutzleiter (Ausführung 2x PE) anzuschließen.
- Ein ausführliches Kompendium von Steckverbinder-Begriffen befindet sich am Ende dieses Kapitels.
- Nachstehend aufgeführte Auszüge aus Normen dienen der allgemeinen Information. Im konkreten Anwendungsfall sind die jeweils gültigen Normen anzuwenden.
- Prüfverfahren nach IEC 60512 entsprechen den Prüfverfahren nach DIN EN 60512 oder DIN IEC 60512. Die DIN IEC 60664-1 entspricht DIN VDE 0110-1

#### Anschlussstechniken

##### • Schraubverbindung

Schraubklemmen werden nach EN 60999-1/VDE 0609 bemessen. Die Gewindegröße in Abhängigkeit vom Leiterquerschnitt sowie das dazugehörige Anzugs- und Prüfdrehmoment können untenstehender Tabelle 1 entnommen werden.

Tabelle 1

Leiterquerschnitt (mm <sup>2</sup> )	1	1,5	2,5	4	6	10
Schraubengewinde	M 2,6	M 3	M 3	M 3,5	M 4	M 4
Prüfdrehmoment (Ncm)	40	50	50	80	120	120

Die Ausziehungskräfte (Staubereich) der Leiter aus einer Schraubverbindung eines Kontaktelementes zeigt das untenstehende Diagramm 1 für eine Klemmschraube M 3, angezogen mit einem Drehmoment von 50 Ncm.

Diagramm 1

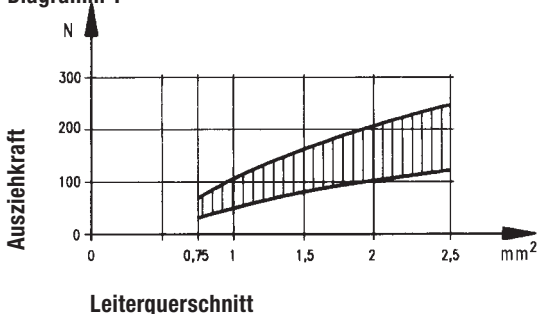

### ! General technical information

Remarks:

- The Safty of connectors/connectors with braking capacity (CBC) depends on the right selection of products, the correct installation and a proper assembly.
- Decisions for the application of connectors are the requirements of the equipment specifications. This is especially the case for the definition of the rated voltage and the related clearances and creepage distances.
- All rated data for the connectors listed in this catalogue is based on overvoltage category III and pollution degree 3 (machine tool application).
- All technical data is specified for connectors, which are not under load when mated or disconnected. If in special cases connectors can be used in the sense of plug and socket devices (connector with breaking capacity), this is mentioned in the brief information of the particular section.
- Correct mounting will protect against electrical shock when mating the connectors.
- It connectors are mounted in non conductive housings both protective earthing terminals shall be mounted.
- A detailed connector glossary can be found at the end of this catalogue.
- All mentioned excerpts of standards are for general information only. For specific cases the valid original standards have to be consulted.
- Test methods acc. IEC 60512 comply with test methods acc. DIN EN 60512 or DIN IEC 60512. IEC 60664-1 complies with DIN VDE 0110-1

#### Termination methods

##### • Screw connection

Screw clamps are designed acc. to EN 60999-1/VDE 0609. Chart 1 below shows the screw size depending on wire size and the required clamping and testing torque.

Chart 1

Wire size (mm <sup>2</sup> )	1	1,5	2,5	4	6	10
Screw size	M 2,6	M 3	M 3	M 3,5	M 4	M 4
Test torque (Ncm)	40	50	50	80	120	120

Diagram 1 below shows the range of tensile strength for a screw connection with a clamp screw M3, fastened with a torque of 50 Ncm, depending on the wire size.

Diagram 1

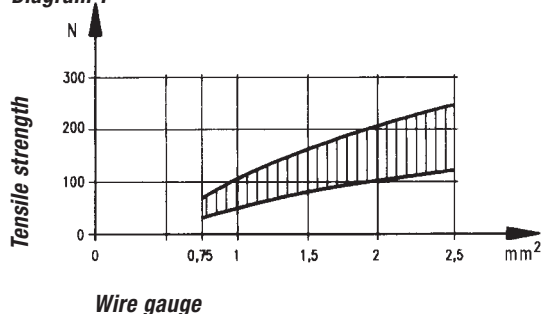

### • Crimpverbindung

Eine Crimpverbindung ist eine nicht lösbare elektrische Verbindung zwischen einem Leiter und einem Crimpkontakt mit Hilfe der Crimptechnik. Durch genau auf Crimphülse und Leiterquerschnitt abgestimmte Crimpprofile werden durch Druck und gezielte Verformung zuverlässige elektrische Verbindungen hergestellt. Es gibt offene Crimphülsen (gestanzte Kontakte) und geschlossene Crimphülsen (gedrehte Kontakte).

Die wesentlichen Vorteile von Crimpverbindungen sind:

- Rationelle Verarbeitung der Kontakte
- Konstante elektrische und mechanische Werte durch gleichbleibende Crimpqualität.

**(Eine ausführliche Beschreibung der Crimptechnologie finden Sie in unserem Katalog „Werkzeuge“.)**

Die Anforderungen an Crimpverbindungen sind in der DIN EN 60352-2, festgelegt.

Ein wesentliches Merkmal für die Qualität einer Crimpverbindung ist die erreichte Zugfestigkeit des Anschlusses. Sie kann mit einfachen Mitteln zur Überwachung der Qualität herangezogen werden. Aus untenstehender Tabelle 2 kann die Mindest-Zugfestigkeit entnommen werden.

**Tabelle 2**

#### Zugfestigkeit von Crimpverbindungen

Leiterquerschnitt		Zugfestigkeit
mm <sup>2</sup>	AWG <sup>1)</sup>	N
0,05	30	6
0,08	28	11
0,12	26	15
0,14		18
0,22	24	28
0,25		32
0,32	22	40
0,5	20	60
0,75		85
0,82	18	90
1,0		108
1,3	16	135
1,5		150
2,1	14	200
2,5		230
3,3	12	275
4,0		310
5,3	10	355
6,0		360
8,4	8	370
10,0		380

<sup>1)</sup>Nur zur Information

### • Crimp connection

A crimp connection is a non-detachable electrical connection between a wire and a crimp contact produced with the crimp technology. Precise crimping dies are matched to the crimp barrel and the wire size and a defined deformation results in a reliable electrical connection. There are open barrels (stamped contacts) and closed crimp barrels (turned contacts).

The main advantages of crimp connections are:

- Efficient termination of contacts.
- Reproducible electrical and mechanical figures by a constant crimp quality.

**(A detailed description of the crimp technology can be found in our catalogue „tools“.)**

The requirements for crimp connections are defined in DIN EN 60352-2.

An important point for the quality of a crimp connection is the achieved tensile strength of the termination. Measuring the tensile strength is a practicable means for quality control purposes. Chart 2 below shows the required minimum tensile strength for open and closed barrels according to the wire size.

**Chart 2**

#### Tensile strength for crimp connections

Wire size		Tensile strength
mm <sup>2</sup>	AWG <sup>1)</sup>	N
0,05	30	6
0,08	28	11
0,12	26	15
0,14		18
0,22	24	28
0,25		32
0,32	22	40
0,5	20	60
0,75		85
0,82	18	90
1,0		108
1,3	16	135
1,5		150
2,1	14	200
2,5		230
3,3	12	275
4,0		310
5,3	10	355
6,0		360
8,4	8	370
10,0		380

<sup>1)</sup> only for information

Da in verschiedenen Bereichen der Industrie auch mit Leitern nach der amerikanischen Drahtlehre AWG (American Wire Gauge) gearbeitet wird, folgt hiernach Tabelle 3 zur Umrechnung von AWG in mm<sup>2</sup>.

Tabelle 3

AWG	Leiteraufbau	Leiter-Ø	Leiterquerschnitt
30	1 x 0,25 7 x 0,10	0,25 mm	0,05 mm <sup>2</sup>
		0,36 mm	0,06 mm <sup>2</sup>
28	1 x 0,32 7 x 0,13	0,32 mm	0,08 mm <sup>2</sup>
		0,38 mm	0,09 mm <sup>2</sup>
26	1 x 0,40 7 x 0,16 19 x 0,10	0,40 mm	0,13 mm <sup>2</sup>
		0,48 mm	0,14 mm <sup>2</sup>
		0,51 mm	0,15 mm <sup>2</sup>
24	1 x 0,51 7 x 0,20 19 x 0,13	0,51 mm	0,21 mm <sup>2</sup>
		0,61 mm	0,23 mm <sup>2</sup>
		0,64 mm	0,24 mm <sup>2</sup>
22	1 x 0,64 7 x 0,25 19 x 0,16	0,64 mm	0,33 mm <sup>2</sup>
		0,76 mm	0,36 mm <sup>2</sup>
		0,81 mm	0,38 mm <sup>2</sup>
20	1 x 0,81 7 x 0,32 19 x 0,20	0,81 mm	0,52 mm <sup>2</sup>
		0,97 mm	0,56 mm <sup>2</sup>
		1,02 mm	0,62 mm <sup>2</sup>
18	1 x 1,02 19 x 0,25	1,02 mm	0,79 mm <sup>2</sup>
		1,27 mm	0,96 mm <sup>2</sup>
16	19 x 0,29	1,44 mm	1,23 mm <sup>2</sup>
14	19 x 0,36	1,80 mm	1,95 mm <sup>2</sup>
12	19 x 0,46	2,29 mm	3,09 mm <sup>2</sup>
10	37 x 0,40	3,10 mm	4,60 mm <sup>2</sup>
8	133 x 0,29	4,0 mm	8,80 mm <sup>2</sup>
6	133 x 0,36	5,5 mm	13,5 mm <sup>2</sup>

Zu beachten ist, dass Leiter mit gleicher AWG-Nummer, aber unterschiedlichem Aufbau, leicht unterschiedliche Querschnitte aufweisen!

Tabelle 4

Aufbau und Abmessungen von Kupferleitungen

Leiterquerschnitt	Leiteraufbau	Leiter-Ø
0,09 mm <sup>2</sup>	12 x 0,10	0,48 mm
0,14 mm <sup>2</sup>	18 x 0,10	0,50 mm
0,25 mm <sup>2</sup>	14 x 0,15	0,70 mm
0,34 mm <sup>2</sup>	7 x 0,25	0,78 mm
0,5 mm <sup>2</sup>	16 x 0,20	1,0 mm
0,75 mm <sup>2</sup>	24 x 0,20	1,2 mm
1,0 mm <sup>2</sup>	32 x 0,20	1,4 mm
1,5 mm <sup>2</sup>	30 x 0,25	1,6 mm
2,5 mm <sup>2</sup>	35 x 0,30	2,2 mm
4,0 mm <sup>2</sup>	56 x 0,30	2,8 mm
6,0 mm <sup>2</sup>	19 x 0,64	3,4 mm
10 mm <sup>2</sup>	19 x 0,80	4,3 mm

The chart below allows a cross reference between American Wire Gauge (AWG) and metric wire sizes (mm<sup>2</sup>).

Chart 3

AWG	Wire composition	Wire diameter	Wire size
30	1 x 0,25 7 x 0,10	0,25 mm	0,05 mm <sup>2</sup>
		0,36 mm	0,06 mm <sup>2</sup>
28	1 x 0,32 7 x 0,13	0,32 mm	0,08 mm <sup>2</sup>
		0,38 mm	0,09 mm <sup>2</sup>
26	1 x 0,40 7 x 0,16 19 x 0,10	0,40 mm	0,13 mm <sup>2</sup>
		0,48 mm	0,14 mm <sup>2</sup>
		0,51 mm	0,15 mm <sup>2</sup>
24	1 x 0,51 7 x 0,20 19 x 0,13	0,51 mm	0,21 mm <sup>2</sup>
		0,61 mm	0,23 mm <sup>2</sup>
		0,64 mm	0,24 mm <sup>2</sup>
22	1 x 0,64 7 x 0,25 19 x 0,16	0,64 mm	0,33 mm <sup>2</sup>
		0,76 mm	0,36 mm <sup>2</sup>
		0,81 mm	0,38 mm <sup>2</sup>
20	1 x 0,81 7 x 0,32 19 x 0,20	0,81 mm	0,52 mm <sup>2</sup>
		0,97 mm	0,56 mm <sup>2</sup>
		1,02 mm	0,62 mm <sup>2</sup>
18	1 x 1,02 19 x 0,25	1,02 mm	0,79 mm <sup>2</sup>
		1,27 mm	0,96 mm <sup>2</sup>
16	19 x 0,29	1,44 mm	1,23 mm <sup>2</sup>
14	19 x 0,36	1,80 mm	1,95 mm <sup>2</sup>
12	19 x 0,46	2,29 mm	3,09 mm <sup>2</sup>
10	37 x 0,40	3,10 mm	4,60 mm <sup>2</sup>
8	133 x 0,29	4,0 mm	8,80 mm <sup>2</sup>
6	133 x 0,36	5,5 mm	13,5 mm <sup>2</sup>

It has to be noted that wires of the same AWG number but with different composition have slightly different mm<sup>2</sup>.

Chart 4

Composition and Dimensions of Copper Wires

Wire Size	Wire Composition	Wire diameter
0,09 mm <sup>2</sup>	12 x 0,10	0,48 mm
0,14 mm <sup>2</sup>	18 x 0,10	0,50 mm
0,25 mm <sup>2</sup>	14 x 0,15	0,70 mm
0,34 mm <sup>2</sup>	7 x 0,25	0,78 mm
0,5 mm <sup>2</sup>	16 x 0,20	1,0 mm
0,75 mm <sup>2</sup>	24 x 0,20	1,2 mm
1,0 mm <sup>2</sup>	32 x 0,20	1,4 mm
1,5 mm <sup>2</sup>	30 x 0,25	1,6 mm
2,5 mm <sup>2</sup>	35 x 0,30	2,2 mm
4,0 mm <sup>2</sup>	56 x 0,30	2,8 mm
6,0 mm <sup>2</sup>	19 x 0,64	3,4 mm
10 mm <sup>2</sup>	19 x 0,80	4,3 mm

**Strombelastbarkeit**



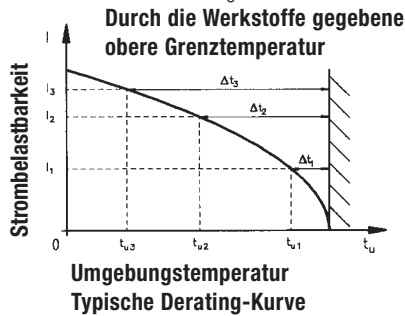

Die Strombelastbarkeit eines Steckverbinders wird mit einer Derating-Kurve dargestellt. Aus ihr kann abgelesen werden, welche Ströme dauernd und gleichzeitig über alle Kontakte fließen dürfen. Die Kurve wird durch Prüfung ermittelt. Als Basis dient dazu die Norm DIN EN 60512. Die obere Grenztemperatur wird durch die verwendeten Kontakt- und Isolierwerkstoffe bestimmt. Die Summe aus der Umgebungstemperatur und der durch die Strombelastung hervorgerufenen Übertemperatur darf die obere Grenztemperatur des Steckverbinders nicht übersteigen. Somit ist die Strombelastbarkeit kein konstanter Wert, sondern sinkt mit steigender Umgebungstemperatur. Als allgemeines Beispiel sei gesagt, dass bei einem vorgegebenen Steckverbinder, der bei einer Umgebungstemperatur von 40°C mit einem Dauerstrom von 16A auf allen Kontakten belastet werden darf, dieser Wert bei einer Umgebungstemperatur von 80°C auf z.B. 12A sinken kann. Auf der anderen Seite ist es in der Praxis sehr oft der Fall, dass nicht alle Anschlüsse gleichzeitig mit dem maximal zulässigen Strom belastet werden, so dass dann einzelne Kontakte mit einem höheren Strom als nach der Derating-Kurve zulässig, beaufschlagt werden können. Diese Grenzwerte sind durch Prüfung zu ermitteln.

**Diagramm 3**



**Tabelle 5**

Strombelastbarkeit von Kupferleitern in (A)

Installationsart Installation type	Querschnitt (mm <sup>2</sup> ) Wire size (mm <sup>2</sup> )	0,25	0,34	0,5	0,75	1	1,5	2,5	4	6	10
 B1 Leiter in Schutzrohren und Installationskanälen Wires in conduits and installation channels		-	-	-	7,6	10,4	13,5	18,3	25	32	44
 B2 Kabel und Leitungen in Schutzrohren oder Installationskanälen Cables and conductors in conduits or installation channels		-	-	-	-	9,6	12	16,5	23	29	40
 C Kabel und Leitungen an Wänden Cables and conductors along walls		4,0	5,0	7,1	9,1	11,7	15,2	21	28	36	50
 E Kabel und Leitungen auf Kabeltrassen Cables and conductors on plank		4,0	5,0	7,1	9,1	11,5	16,1	22	30	37	52

Darstellung in Anlehnung an DIN EN 60204 für PVC-isolierte Kupferleiter in einer Umgebungstemperatur von +40°C unter Dauerbetriebsbedingungen. Für abweichende Bedingungen wie andere Temperaturen, Installationen, Isoliermaterialien oder Leitern sind entsprechende Korrekturfaktoren zu verwenden (siehe nächste Seite).

**Current carrying capacity**

The current carrying capacity of a connector is shown by a derating curve. The curve shows the currents that the connector can carry continuously and simultaneously through all its contacts. The curve is determined by testing following the standard DIN EN 60512. The upper temperature is limited by the contact and insulation material used. The sum of the ambient temperature and the temperature created by the current flow may not exceed the upper temperature. This means that the current carrying capacity has no fixed value but decreases with increasing ambient temperatures.

As a general example it can be said that a given connector which can carry 16A through all its contacts at 40°C ambient temperature can carry less, e.g. 12A, at an ambient temperature of 80°C. On the other hand it is often the case that not all contacts carry the whole rated current, which means that some single contacts may carry a higher current than that according to the derating curve. These currents have to be defined by testing.

**Diagram 3**

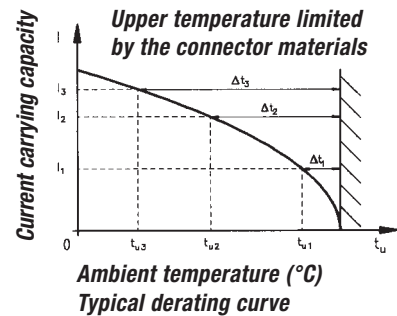

**Chart 5**

Current carrying capacity of copper wires in (A)

Description according to DIN EN 60204 for PVC insulated copper wires with a working temperature of +40C. For other requirements, such as for other temperatures, mountings, or wires corresponding correction factors are used (see next page).

**Reduktionsfaktoren**

Die Werte in der Tabelle 5 beziehen sich auf eine Umgebungstemperatur von 40°C. Für andere Umgebungstemperaturen muss der Wert mit den Faktoren aus der folgenden Tabelle 6 korrigiert werden.

**Tabelle 6**

Umgebungstemperatur (°C)	Korrekturfaktor
30	1,15
35	1,03
40	1,00
45	0,91
50	0,82
55	0,71
60	0,58

Für Installationen mit vielen belasteten Kabeln und Leitungen/Paaren verringern sich die Werte der Strombelastbarkeit entsprechend den nachfolgenden Tabellen 7 und 8.

**Tabelle 7**

Reduktionsfaktoren für Leitungsanhäufung

Art der Installation <i>Installation type</i>	Anzahl der belasteten Kabel und Leitungen / Paare <i>Number of cables and conductors / pairs under load</i>			
	2	4	6	9
Drehstromkabel und -leitung <i>Threephase cable and conductor</i>				
B1 und/and B2	0,80	0,85	0,87	0,86
C	0,65	0,75	0,78	0,76
E-einlagig / <i>one row</i>	0,57	0,72	0,75	0,72
E-mehrlagig / <i>multi row</i>	0,50	0,70	0,73	0,88
Gleichstromleitung (Paar), unabhängig von der Installationsart <i>DC conductor (pair), independent of installation type</i>	1,0	0,76	0,64	0,43

**Tabelle 8**

Reduktionsfaktoren für Mehraderkabel (-leitungen) bis zu 10 mm<sup>2</sup>

Anzahl der belasteten Leitungen (Paare) <i>Number of conductors (pairs) under load</i>	Wechselstrom (Leiter >1 mm <sup>2</sup> ) <i>AC (conductor &gt; 1 mm<sup>2</sup>)</i>	Gleichstrom (Paare 0,2 bis 0,75 mm <sup>2</sup> ) <i>DC (Pairs 0,2 to 0,75 mm<sup>2</sup>)</i>
5	0,75	0,52
7	0,65	0,45
10	0,55	0,39
24	0,40	0,27

Leiter von Steuerkreisen benötigen normalerweise keine Herabsetzung.

**Reduction values**

The values in chart 5 are based on an ambient temperature of 40 °C. For other ambient temperatures the values have to be adjusted using the correction values of chart 6 below.

**Chart 6**

Ambient temperature (°C)	Correction value
30	1,15
35	1,03
40	1,00
45	0,91
50	0,82
55	0,71
60	0,58

For installations with many cables and conductors under load the current carrying capacity is reduced according to the two following charts 7 and 8.

**Chart 7**

Reduction values for accumulated conductors

**Chart 8**

Reduction values for multicore cable and conductors up to 10mm<sup>2</sup>

Conductors of control circuits generally do not need a reduction.



**Stoßstrombelastbarkeit**

Eine besondere Belastung kann sich für Steckverbinder und deren Kontakte durch einen Stoßstrom ergeben, der z.B. durch einen Kurzschluss in der Anlage oder durch Schaltvorgänge entstehen kann. Die kurzzeitig sehr hohe Stromerwärmung kann nach außen nicht schnell genug abgeführt werden, so dass es zu einer örtlich sehr starken Erwärmung der Kontakte kommt, die z.B. in extremen Fällen zu einer Verschweißung führen kann. Durch unsere robuste Kontaktkonstruktion sind die hier beschriebenen Steckverbinder gegenüber Stoßströmen relativ unempfindlich. Richtwerte können dem nachfolgenden Diagramm 4 entnommen werden.

**Diagramm 4**

Stoßstrombelastbarkeit von Einzelkontakten

**Impulse current carrying capacity**

A surge can happen to a connector and its contacts by an impulse current, e.g. through a short circuit in the system or by switching operations. The short-timed high current heat cannot be transferred outside fast enough so the contacts are stressed by the high temperature which in the worst case can lead to a local weld. The robust design of our connectors prevents most damage by impulse currents.

The diagram 4 below can be used as a guideline.

**Diagramm 4**

Impulse current carrying capacity of single contacts

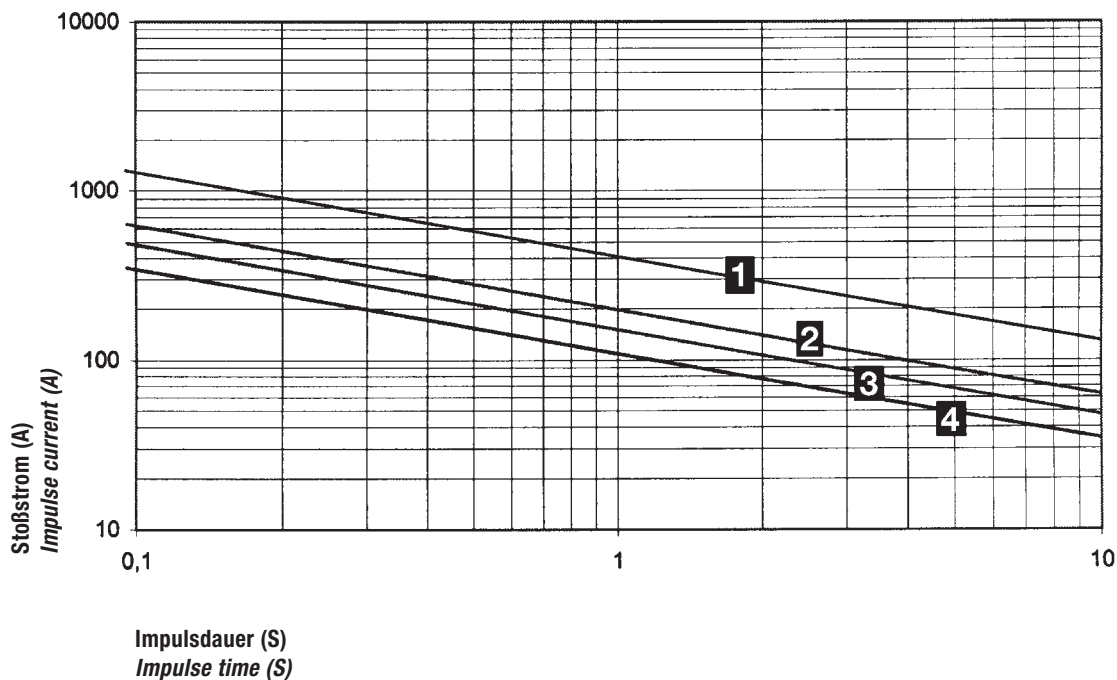

Kurve Nr.	Steckverbinder-Bauform	Curve No.	Connector style
1	C146 E oder A mit Schraubkontakt	1	C146 E or A with screw contact
2	C146 E mit gestanztem Crimpkontakt	2	C146 E with stamped crimp contact
3	C146 S mit gestanztem Crimpkontakt	3	C146 S with stamped crimp contact
4	C146 D mit gestanztem Crimpkontakt	4	C146 D with stamped crimp contact

**Spannungseinstufung der Steckverbinder****Allgemeines**

Zur Spannungseinstufung von Steckverbindern werden die Luft- und Kriechstrecken herangezogen. Die Beurteilung und Bemessung der Luft- und Kriechstrecken hat sich durch die Einführung der Isolationskoordination geändert.

Es gelten dafür die folgenden Normen:

IEC 60664-1/10.92  
Insulation coordination for equipment within low-voltage systems

DIN VDE 0110-1/4.97  
Isolationskoordination für elektrische Betriebsmittel in Niederspannungsanlagen

Isolationskoordination umfasst die Auswahl der elektrischen Isolationseigenschaften eines Betriebsmittels hinsichtlich dessen Anwendung und in Bezug auf seine Umgebung.

**Luftstrecken**

Die Luftstrecke ist die kürzeste Entfernung in Luft zwischen zwei leitenden Teilen. Ein wichtiger Punkt bei der Bemessung von Luftstrecken ist zunächst die Festlegung der Überspannungskategorie. Die Norm hat die möglichen Überspannungen in die nachstehenden vier Kategorien eingeteilt:

**Überspannungskategorie I**

Betriebsmittel, die zur Anwendung in Geräten oder Teilen von Anlagen bestimmt sind, in denen keine Überspannungen auftreten können. Hierunter fallen Geräte, die vorwiegend mit Kleinspannungen betrieben werden.

**Überspannungskategorie II**

Betriebsmittel, die zur Anwendung in Anlagen oder Teilen von diesen bestimmt sind, in denen Blitzüberspannungen nicht berücksichtigt werden müssen, aber wohl Überspannungen durch Schaltvorgänge. Hierunter fallen z.B. elektrische Haushaltsgeräte.

**Überspannungskategorie III**

Betriebsmittel, die zur Anwendung in Anlagen oder Teilen von diesen bestimmt sind, bei denen Blitzüberspannungen nicht berücksichtigt werden müssen, wohl aber Überspannungen durch Schaltvorgänge und an die im Hinblick auf die Sicherheit und Verfügbarkeit des Betriebsmittels oder von davon abhängigen Netzen besondere Anforderungen gestellt werden. Hierunter fallen Betriebsmittel für feste Installationen, z.B. Schutzeinrichtungen, Schütze, Schalter und Steckdosen.

**Überspannungskategorie IV**

Betriebsmittel, die zur Anwendung in Anlagen oder Teilen von diesen bestimmt sind, bei denen Blitzüberspannungen zu berücksichtigen sind. Hierunter fallen Betriebsmittel zum Anschluss an Freileitungen, z.B. Rundsteuerempfänger, Zähler.

**Voltage grading of connectors****General**

*Clearances and creepage distances are the base for voltage grading of connectors. Valuation and dimensioning of clearances and creepage distances have changed since the introduction of insulation coordination.*

*The following standards apply for this:*

*IEC 60664-1/10.92  
Insulation coordination for equipment within low-voltage systems*

*DIN VDE 0110-1/4.97  
Isolationskoordination für elektrische Betriebsmittel in Niederspannungsanlagen*

*Insulation coordination comprises the selection of the electrical insulation performances of the equipment, taking into account the expected use and its environment.*

**Clearances**

*The clearance is the shortest distance in air between two conductive parts. An important point for the dimensioning of clearances is the determination of the overvoltage category. The above standard specifies the possible overvoltages into the four following categories:*

**Overvoltage category I**

*Equipment intended for the use in appliances or parts of installations in which no overvoltage can occur.  
Examples are low-voltage equipments.*

**Overvoltage category II**

*Equipment intended for the use in installations or parts of it in which lightning overvoltages do not need to be considered, but switching overvoltages generated by the equipment do need to be considered.  
Examples are household appliances.*

**Overvoltage category III**

*Equipment intended for the use in installations or parts of it in which lightning overvoltages do not need to be considered, however switching overvoltages generated by the equipment, and for cases where the reliability and the availability of the equipment or its dependent circuits are subject to special requirements.  
Examples are protecting means, switches and sockets.*

**Overvoltage category IV**

*Equipment intended for the use in installations or parts of it in which lightning overvoltage has to be considered.  
Examples are electricity meters, overcurrent protection switches.*

Liegt die Überspannungskategorie fest, dann kann je nach Nennspannungsbereich des Stromversorgungs-Systems und der Überspannungskategorie die Bemessungs-Stoßspannung für das Betriebsmittel ermittelt werden. Es gilt dabei die folgende Tabelle 9:

*Once the overvoltage category has been defined the rated impulse withstand voltage can be selected for the equipment based on the nominal voltage of the supply system and the overvoltage category using chart 9 below:*

Tabelle 9

Chart 9

Nennspannung des Stromversorgungs-Systems in V (nach IEC 60038) <i>Nominal voltage of the supply system in V (based on IEC 60038)</i>	Bemessungs-Stoßspannung in kV für Überspannungskategorie <i>Rated impulse voltage in kV for overvoltage category</i>			
Drei-phasige Systeme / <i>Three phase systems</i>	IV	III	II	I
230/400 277/480	6	4	2,5	1,5
400/690	8	6	4	2,5
1000	12	8	6	4

Ist die Bemessungs-Stoßspannung ermittelt, so muss jetzt der Verschmutzungsgrad entsprechend der zu erwartenden Verschmutzung der unmittelbaren Umgebung des Betriebsmittels festgelegt werden. Hierzu dienen die folgenden vier festgelegten Grade:

*After the rated impulse withstand voltage has been selected the pollution degree must be defined taking the expected pollution around the equipment into account. The following four degrees of pollution are established:*

#### Verschmutzungsgrad 1

Es tritt keine oder nur trockene, nicht leitfähige Verschmutzung auf. Die Verschmutzung hat keinen Einfluss.

#### *Pollution degree 1*

*No pollution or only dry, non-conductive pollution occurs. The pollution has no influence.*

#### Verschmutzungsgrad 2

Es tritt nur nicht leitfähige Verschmutzung auf. Gelegentlich muss jedoch mit vorübergehender Leitfähigkeit durch Betauung gerechnet werden.

#### *Pollution degree 2*

*Only non-conductive pollution occurs except occasionally a temporary conductivity caused by condensation is to be expected.*

#### Verschmutzungsgrad 3

Es tritt leitfähige Verschmutzung auf oder trockene, nicht leitfähige Verschmutzung, die leitfähig wird, da Betauung zu erwarten ist.

#### *Pollution degree 3*

*Conductive pollution occurs or dry non-conductive pollution occurs which becomes conductive due to condensation which is to be expected.*

#### Verschmutzungsgrad 4

Die Verunreinigung führt zu einer beständigen Leitfähigkeit, hervorgerufen durch leitfähigen Staub, Regen oder Schnee.

#### *Pollution degree 4*

*The pollution generates persistent conductivity caused by conductive dust or by rain or snow.*

**Zu beachten ist, dass Teile von Steckverbindern und Steckvorrichtungen mit ausreichender Kapselung (min. IP 54) auch nach einem niedrigeren Verschmutzungsgrad bemessen werden können. Dies gilt auch für Steckverbinder im Trennbereich, bei denen die Kapselung im gesteckten Zustand durch das Steckverbindergehäuse erreicht wird und die nur für Prüf- und Wartungszwecke getrennt werden.**

***It has to be noted that for a connector or plug and socket device with a degree of protection of min. IP 54 the parts inside the enclosure may be dimensioned for a lower pollution degree. This also applies to mated connectors which enclosure is ensured through the connector housing and which may only be disengaged for test and maintenance purposes.***

Aus der Bemessungs-Stoßspannung und dem Verschmutzungsgrad können jetzt aus Tabelle 10 die Mindest-Luftstrecken ermittelt werden.

*When impulse withstand voltage and the pollution degree are defined the minimum clearances can be selected from chart 10.*

Tabelle 10

Chart 10

Bemessungs- Stoßspannung in kV <i>Impulse withstand voltage in kV</i>	Mindestluftstrecken in mm bis zu 2000 m über NN <i>Minimum clearances in air in mm up to 2000 m above sea level</i>							
	Fall A (inhomogenes Feld) <i>Case A (non homogeneous field)</i>				Fall B (homogenes Feld) <i>Case B (homogeneous field)</i>			
	Verschmutzungsgrad <i>Pollution degree</i>				Verschmutzungsgrad <i>Pollution degree</i>			
	1	2	3	4	1	2	3	4
0,33	0,01	0,2	0,8	1,6	0,01	0,2	0,8	1,6
0,40	0,02				0,02			
0,50	0,04				0,04			
0,60	0,06	0,25	1,0	2	0,06	0,3	1,2	2
0,80	0,10				0,10			
1,0	0,15				0,15			
1,2	0,25	1,0	1,5	3	0,2	0,45	1,5	3
1,5	0,5				0,5			
2,0	1,0				1,0			
2,5	1,5	1,5	2	4	0,6	0,6	1,2	4
3,0	2				2			
4,0	3				3			
5,0	4	4	4	5,5	1,5	1,5	1,5	2
6,0	5,5				5,5			
8,0	8				8			
10	11	11	11	11	3,5	3,5	3,5	3,5
12	14				14			
15	18				18			
20	25	25	25	25	8	8	8	8
25	33				33			
30	40				40			
40	60	60	60	60	17	17	17	17
50	75				75			
60	90				90			
80	130	130	130	130	35	35	35	35
100	170				170			

Bei der Festlegung der Mindestluftstrecken von Steckverbindern sind in der Regel die Werte des inhomogenen Falls anzuwenden bzw. ist die entsprechende Luftstrecke durch eine Spannungsprüfung zu überprüfen.

#### Kriechstrecken

Die Kriechstrecke ist die kürzeste Entfernung entlang der Oberfläche eines Isolierstoffes zwischen zwei leitenden Teilen.

Zur Bemessung der Kriechstrecke wird die aus der entsprechenden Netzart abgeleitete Bemessungsspannung und die bereits bei der Luftstrecke gewählte Zuordnung des Verschmutzungsgrades herangezogen. Außerdem wird die Kriechwegbildung des vom Hersteller verwendeten Isolierstoffes berücksichtigt. Die Isolierstoffe werden entsprechend ihrem Kriechwegbildungsfaktor CTI (Comparative Tracking Index) in vier Gruppen eingeteilt:

Isolierstoffgruppe I	$600 \leq \text{CTI}$
Isolierstoffgruppe II	$400 \leq \text{CTI} < 600$
Isolierstoffgruppe IIIa	$175 \leq \text{CTI} < 400$
Isolierstoffgruppe IIIb	$100 \leq \text{CTI} < 175$

When defining the minimum clearances for connectors generally the values of the inhomogeneous field can be chosen or the required clearance has to be defined by a voltage test.

#### Creepage distances

The creepage distance is the shortest distance along the surface of the insulating material between two conductive parts.

For the dimensioning of the creepage distance the following factors are taken into account: the rated voltage, the pollution degree and the tracking formation of the insulating material. The materials are separated into four groups according to their CTI values (Comparative Tracking Index):

Material group I	$600 \leq \text{CTI}$
Material group II	$400 \leq \text{CTI} < 600$
Material group IIIa	$175 \leq \text{CTI} < 400$
Material group IIIb	$100 \leq \text{CTI} < 175$

Die Mindestkriechstrecken können dann aus der Tabelle 11 entnommen werden.

The minimum creepage distances can be selected from chart 11.

Tabelle 11

Chart 11

Bemes- sungs- spannung U-eff Rated voltage U in V	Mindestkriechstrecke in mm / Min. creepage distance in mm														
	Gedruckte Schaltungen Printed circuits			Übrige Betriebsmittel / Other devices											
	Verschmutzungs- grad Pollution degree			Verschmutzungsgrad Pollution degree				Verschmutzungsgrad Pollution degree				Verschmutzungsgrad Pollution degree			
	1		2	1		2		3		4		1		2	
	1	2	Isolierstoffgruppe Material group		Isolierstoffgruppe Material group		Isolierstoffgruppe Material group		Isolierstoffgruppe Material group		I	II	III a	III b	
2)	3)	2)	I	II	III a	III b	I	II	III a	III b	I	II	III a	III b	
10	0,025	0,04	0,08	0,4	0,4	0,4		1	1	1		1,6	1,6	1,6	
12,5	0,025	0,04	0,09	0,42	0,42	0,42		1,05	1,05	1,05		1,6	1,6	1,6	
16	0,025	0,04	0,1	0,45	0,45	0,45		1,1	1,1	1,1		1,6	1,6	1,6	
20	0,025	0,04	0,11	0,48	0,48	0,48		1,2	1,2	1,2		1,6	1,6	1,6	
25	0,025	0,04	0,125	0,5	0,5	0,5		1,25	1,25	1,25		1,7	1,7	1,7	
32	0,025	0,04	0,14	0,53	0,53	0,53		1,3	1,3	1,3		1,8	1,8	1,8	
40	0,025	0,04	0,16	0,56	0,8	1,1		1,4	1,6	1,8		1,9	2,4	3	
50	0,025	0,04	0,18	0,6	0,85	1,2		1,5	1,7	1,9		2	2,5	3,2	
63	0,04	0,063	0,2	0,63	0,9	1,25		1,6	1,8	2		2,1	2,6	3,4	
80	0,063	0,1	0,22	0,67	0,95	1,3		1,7	1,9	2,1		2,2	2,8	3,6	
100	0,1	0,16	0,25	0,71	1	1,4		1,8	2	2,2		2,4	3,0	3,8	
125	0,16	0,25	0,28	0,75	1,05	1,5		1,9	2,1	2,4		2,5	3,2	4	
160	0,25	0,4	0,32	0,8	1,1	1,6		2	2,2	2,5		3,2	4	5	
200	0,4	0,63	0,42	1	1,4	2		2,5	2,8	3,2		4	5	6,3	
250	0,56	1	0,56	1,25	1,8	2,5		3,2	3,6	4		5	6,3	8	
320	0,75	1,6	0,75	1,6	2,2	3,2		4	4,5	5		6,3	8	10	
400	1	2	1	2	2,8	4		5	5,6	6,3		8	10	12,5	
500	1,3	2,5	1,3	2,5	3,6	5		6,3	7,1	8,0		10	12,5	16	
630	1,8	3,2	1,8	3,2	4,5	6,3		8	9	10		12,5	16	20	
800	2,4	4	2,4	4	5,6	8		10	11	12,5		16	20	25	
1000	3,2	5	3,2	5	7,1	10		12,5	14	16		20	25	32	
1250			4,2	6,3	9	12,5		16	18	20		25	32	40	
1600			5,6	8	11	16		20	22	25		32	40	50	
2000			7,5	10	14	20		25	28	32		40	50	63	
2500			10	12,5	18	25		32	36	40		50	63	80	
3200			12,5	16	22	32		40	45	50		63	80	100	
4000			16	20	28	40		50	56	63		80	100	125	
5000			20	25	36	50		63	71	80		100	125	160	
6300			25	32	45	63		80	90	100		125	160	200	
8000			32	40	56	80		100	110	125		160	200	250	
10000			40	50	71	100		125	140	160		200	250	320	

Die in diesem Katalog beschriebenen Steckverbinder sind festen Bemessungsspannungen zugeordnet, die sich auf den allgemeinen Anwendungsfall im Maschinenbau beziehen. Liegen davon abweichende Anwendungsfälle vor, so kann aufgrund der obigen Tabelle eine andere Bemessungsspannung ermittelt werden.

Connectors in this catalogue are allocated to fixed rated voltages which apply to the machine building industry. In case of other applications the above chart can be used to determine other rated voltages.

**Schutzarten**

Elektrische Betriebsmittel, zu denen Steckverbinder zählen, müssen aus Sicherheitsgründen gegen Einflüsse von außen, wie z.B. Staub, Fremdkörper, Berührung, Feuchtigkeit und Wasser geschützt werden. Diesen Schutz übernehmen bei Industrie-Steckverbindern die Gehäuse mit ihrer Verriegelung und dem abgedichteten Kabeleinlass.

Den Grad der Schutzart kann man dem Einsatz entsprechend wählen. In der Norm IEC 60529 bzw. DIN EN 60529 sind die Schutzgrade festgelegt und in verschiedene Klassen eingeteilt.

Die Bezeichnung erfolgt in nachstehender Weise:

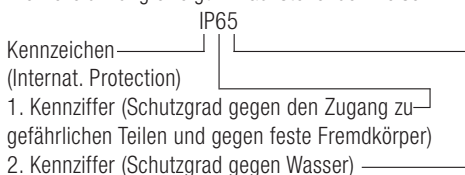

Die nachfolgenden Tabellen 12 und 13 zeigen alle Schutzarten in einer Übersicht.

**Tabelle 12**

1. Kennziffer	Kurzbeschreibung	Definition
0	Nicht geschützt	–
1	Geschützt gegen den Zugang zu gefährlichen Teilen mit dem Handrücken. Geschützt gegen feste Fremdkörper $\varnothing \geq 50$ mm.	Die Sonde, Kugel $\varnothing$ 50 mm, darf nicht voll eindringen und muss ausreichenden Abstand zu gefährlichen Teilen haben.
2	Geschützt gegen den Zugang zu gefährlichen Teilen mit einem Finger. Geschützt gegen feste Fremdkörper $\varnothing \geq 12,5$ mm.	Der gegliederte Prüffinger, $\varnothing$ 12 mm, 80 mm Länge, muss ausreichenden Abstand zu gefährlichen Teilen haben. Die Sonde, $\varnothing$ 12,5 mm, darf nicht voll eindringen.
3	Geschützt gegen den Zugang zu gefährlichen Teilen mit einem Werkzeug. Geschützt gegen feste Fremdkörper $\varnothing \geq 2,5$ mm.	Die Sonde, $\varnothing$ 2,5 mm, darf überhaupt nicht eindringen.
4	Geschützt gegen den Zugang zu gefährlichen Teilen mit einem Draht. Geschützt gegen feste Fremdkörper $\varnothing \geq 1$ mm.	Die Sonde, $\varnothing$ 1 mm, darf überhaupt nicht eindringen.
5	Geschützt gegen den Zugang zu gefährlichen Teilen mit einem Draht. Staubgeschützt.	Die Sonde, $\varnothing$ 1 mm, darf nicht eindringen. Eindringen von Staub ist nicht vollständig verhindert, aber der Staub darf nicht in einer solchen Menge eindringen, dass das zufriedenstellende Arbeiten des Gerätes oder die Sicherheit beeinträchtigt wird.
6	Geschützt gegen den Zugang zu gefährlichen Teilen mit einem Draht. Staubdicht.	Die Sonde, $\varnothing$ 1 mm, darf nicht eindringen. Kein Eindringen von Staub.

**Degree of protection**

Electrical connector devices have to be protected for safety reasons from outside influences like dust, foreign objects, direct contact, moisture and water. This protection is provided on industrial connectors by the housing latching devices and sealed cable entries. The degree of protection depends on the type of intended use. The standard IEC 60529 and/or DIN EN 60529 has specified the degree of protection and divided them into several classes.

The degree of protection is indicated in the following way:

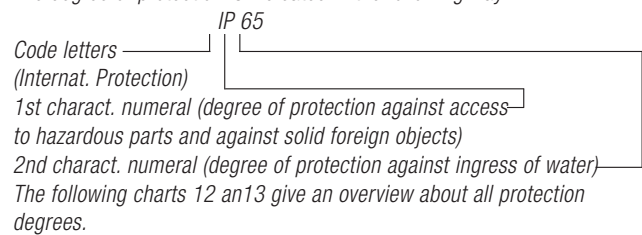
**Chart 12**

1st charact. numeral	Brief description	Definition
0	Non-protected	–
1	Protected against access to hazardous parts with the back of a hand. Protected against solid foreign objects of $\geq 50$ mm $\varnothing$ .	The probe, sphere of 50mm $\varnothing$ , shall not fully penetrate and shall have adequate clearance from hazardous parts.
2	Protected against access to hazardous parts with a finger. Protected against solid foreign objects of $\geq 12,5$ mm $\varnothing$ . Protected against access	The jointed test finger of 12mm $\varnothing$ , 80mm length, shall have adequate clearance from hazardous parts. The probe, sphere of 12,5mm $\varnothing$ , shall not fully penetrate.
3	to hazardous parts with a tool. Protected against solid foreign objects of $\geq 2,5$ mm $\varnothing$ . Protected against access to	The probe of 2,5mm $\varnothing$ shall not penetrate at all.
4	hazardous parts with a wire. Protected against solid foreign objects of $\geq 1$ mm $\varnothing$ .	The probe of 1mm $\varnothing$ shall not penetrate at all.
5	Protected against access to hazardous parts with a wire. Dust-protected.	The probe of 1mm $\varnothing$ shall not penetrate. Intrusion of dust is not totally prevented, but dust shall not penetrate in a quantity to interfere with satisfactory operation of the device or to impair safety.
6	Protected against access to hazardous parts with a wire. Dust-tight.	The probe of 1mm $\varnothing$ shall not penetrate. No intrusion of dust.



Tabelle 13

2. Kennziffer	Kurzbeschreibung	Definition
0	Nicht geschützt	–
1	Geschützt gegen Tropfwasser	Senkrecht fallende Tropfen dürfen keine schädlichen Wirkungen haben.
2	Geschützt gegen Tropfwasser, wenn das Gehäuse bis zu 15° geneigt ist	Senkrecht fallende Tropfen dürfen keine schädlichen Wirkungen haben, wenn das Gehäuse um einen Winkel bis zu 15° beiderseits der Senkrechten geneigt ist.
3	Geschützt gegen Sprühwasser	Wasser, das in einem Winkel bis zu 60° beiderseits der Senkrechten gesprüht wird, darf keine schädlichen Wirkungen haben.
4	Geschützt gegen Spritzwasser	Wasser, das aus jeder Richtung gegen das Gehäuse spritzt, darf keine schädlichen Wirkungen haben.
5	Geschützt gegen Strahlwasser	Wasser, das aus jeder Richtung als Strahl gegen das Gehäuse gerichtet ist, darf keine schädlichen Wirkungen haben.
6	Geschützt gegen starkes Strahlwasser	Wasser, das aus jeder Richtung als starker Strahl gegen das Gehäuse gerichtet ist, darf keine schädlichen Wirkungen haben.
7	Geschützt gegen die Wirkungen beim zeitweiligen Untertauchen in Wasser	Wasser darf nicht in einer Menge eintreten, die schädliche Wirkungen verursacht, wenn das Gehäuse für 30 Min. in 1 m Tiefe in Wasser untergetaucht ist.
8	Geschützt gegen die Wirkungen beim dauernden Untertauchen in Wasser	Wasser darf nicht in einer Menge eintreten, die schädliche Wirkungen verursacht, wenn das Gehäuse dauernd unter Wasser getaucht ist unter Bedingungen, die zwischen Hersteller und Anwender vereinbart werden müssen. Die Bedingungen müssen jedoch schwieriger sein als für die Kennziffer 7.
9K <sup>1)</sup>	Geschützt gegen Wasser bei Hochdruck-/Dampfstrahl-Reinigung	Wasser, das aus jeder Richtung unter stark erhöhtem Druck gegen das Gehäuse gerichtet ist, darf keine schädlichen Wirkungen haben.

1) Anmerkung: Kennziffer nach DIN 40050 Teil 9 Straßenfahrzeuge, IP-Schutzarten

Chart 13

2nd charact. numeral	Brief description	Definition
0	Non-protected	–
1	Protected against vertically falling water drops	Vertically falling drops shall have no harmful effects.
2	Protected against vertically falling water drops when enclosure tilted up to 15°	Vertically falling drops shall have no harmful effects when the enclosure is tilted at any angle up to 15°.
3	Protected against spraying water	Water sprayed at any angle up to 60° shall have no harmful effects.
4	Protected against splashing water	Water splashed against the enclosure from any direction shall have no harmful effects.
5	Protected against water jets	Water projected in jets against the enclosure from any direction shall have no harmful effects.
6	Protected against powerful water jets	Water projected in powerful jets against the enclosure from any direction shall have no harmful effects.
7	Protected against the effects of temporary immersion in water	Intrusion of water in quantities causing harmful effects shall not be possible when the enclosure is temporarily immersed in water for 30 min. in 1 m depth.
8	Protected against the effects of continuous immersion in water	Intrusion of water in quantities causing harmful effects shall not be possible when the enclosure is continuously immersed in water under conditions which shall be agreed between manufacturer and user but which are more severe than for numeral 7.
9 K <sup>1)</sup>	Protected against water during high pressure/steam jet cleaning	Water projected in powerful jets with high pressure and heat against the enclosure from any direction shall have no harmful effects.

1) Remark: Numeral acc. to DIN 40050 part 9, vehicles IP code



**Kabel**

Zum Anschluss an alle Amphenol-Industrie-Steckverbinder wird die Verwendung von handelsüblichen hochflexiblen Kunststoff-Steuerleitungen nach VDE-Vorschriften empfohlen. Auf diese Leitungen sind unsere Steckverbinder in Bezug auf Kontaktanzahl und Kabeleinführung ausgelegt.

Bei der Leitungsauswahl ist darauf zu achten, dass die Leitungen den Steckverbinder nicht angreifen (Lösungsmittel) oder eine mögliche Feuerbeständigkeit aufheben.

**Abdichtung**

Die Abdichtung der Kabeleinführungen aller Amphenol-Industrie-Steckverbinder erfolgt mittels Verschraubungen. Wir verwenden grundsätzlich Dichtringe aus Neoprene, die eine gute Beständigkeit gegen Fette, Öle und Benzin besitzen.

**Auswahl der Verschraubungen**

Neben Dichtringen mit konstantem Innendurchmesser, dessen Maß der Bezeichnung der Verschraubung entspricht, gibt es auch ausschneidbare Dichtringe (Zwiebelringe), bei denen der Innendurchmesser durch Ausschneiden von Ringen in einem gewissen Maße variiert werden kann. Die Auswahl der Verschraubung für verschiedene Kabeldurchmesser (Kabelaufbau) kann von nachfolgendem Diagramm 5 abgeleitet werden (siehe auch Seite 184).

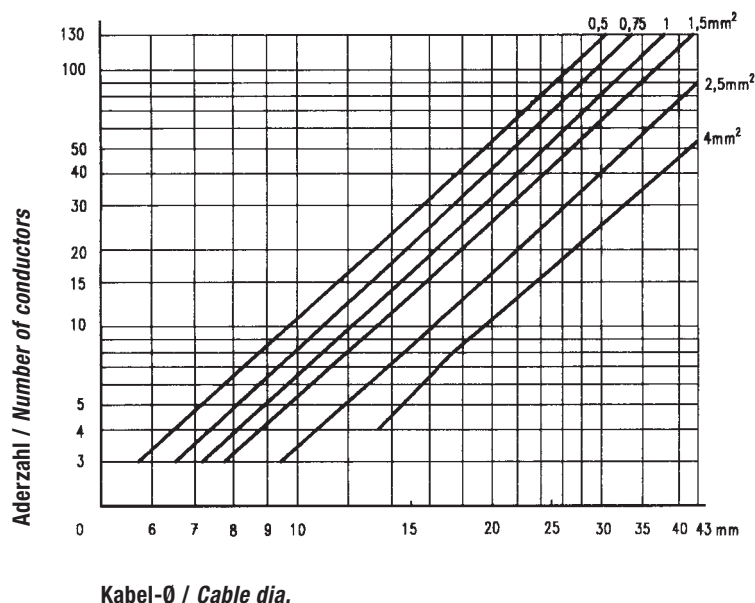
**Diagramm 5****Cable**

For the termination of all Amphenol-industrial connectors we recommend the use of commercially available high flexible cable acc. to VDE or other local specifications. Our connectors are designed to fit these cables especially as far as number of conductors and cable diameters are concerned.

When selecting cables care must be taken that the cables do not affect (solvent) the connector or preserve an existing fire resistance.

**Sealing**

The sealing of the cable entries of all Amphenol-industrial connectors is with gland bushings. All sealings are made from Neoprene which has a good resistance against grease, oil and gasoline.

**Selection of gland bushings**

Beside glands with a fixed inside diameter which equals the number, there are also glands with variable inside diameters available (so-called onion glands). The inside diameter of these glands can be adjusted to the outside cable diameter by cutting out the smaller rings. The selection of the appropriate gland bushing depends on the cable diameter (cable composition) can be made using the following diagram 5 (see page 184).

**Diagram 5**

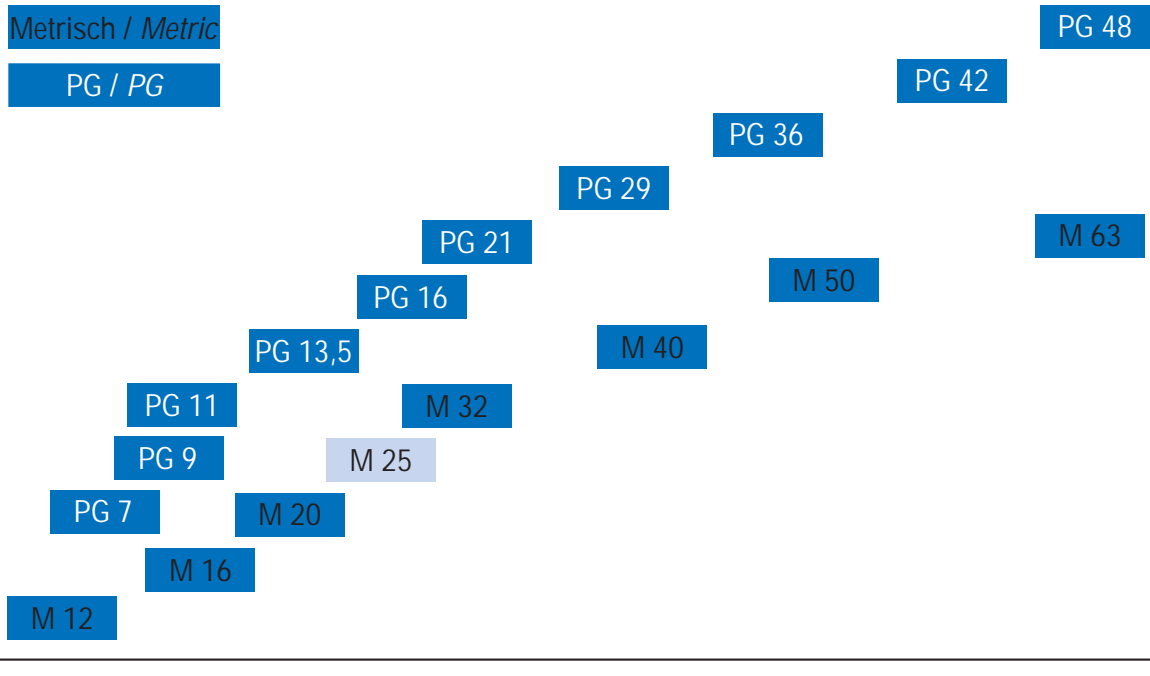

**Dichtbereich / Area of Tightness**

Metrische Kabelverschraubungen passen nur in metrische Gehäuseöffnungen. Zusätzlich bieten wir weiterhin Gehäuse und Verschraubungen mit PG-Gewinde an.

*Metric cable glands fit only into metric housing openings. Additionally we offer further more housings and screw connections with PG threads.*

Aussendurchmesser/ Outer Diameter	PG / PG	Metrisch / Metric
	PG 48	M 63
	PG 42	
	PG 36	M 50
	PG 29	M 40
	PG 21/23	M 32
	PG 16	M 25
	PG 13,5	M 20
	PG 11	
	PG 9	M 16
	PG 7	M 12

**Abschirmung**

Abschirmung innerer oder äußerer elektrischer Felder durch Bildung einer Äquipotentialfläche in Form von Metallklappen oder Metallisierungen auf der Innen- und Außenseite von Kapfen aus Kunststoff. Die Abschirmung wird in der Regel mit dem Schirmgeflecht des angeschlossenen Kabels und mit dem Gerätegehäuse verbunden.

**Bemessungsgrößen, elektrische**

- Bemessungsspannung ist die Spannung, für die der Steckverbinder oder die Steckvorrichtung bemessen ist und auf die bestimmte Betriebsseigenschaften bezogen werden.
- Bemessungsstrom ist der Strom, den ein Steckverbinder oder eine Steckvorrichtung gleichzeitig durch alle Kontakte dauernd (nicht intermittierend) führen kann, ohne dass dabei die obere Grenztemperatur überschritten wird.
- Schaltleistung einer Steckvorrichtung ist die Leistung, welche die Steckvorrichtung unter festgelegten Bedingungen schalten kann.
- Prüfspannung ist die Spannung, der ein Steckverbinder oder eine Steckvorrichtung bei vorgegebenen Bedingungen ohne Durch- oder Überschlagn widersteht.

**Bügelverriegelung**

Verriegelung von zwei Hälften eines Steckverbinderpaares durch ein formschlüssiges Element, das durch einen als Bügel ausgestalteten Hebel betätigt wird. Erst wenn die beiden Hälften vollständig zusammengesteckt sind, kommt der Bügel in seine Endlage.

**Crimpbacken**

Derjenige Teil eines Crimpwerkzeugs, der den Crimpbereich verformt. Er besteht üblicherweise aus dem Crimpamboss, dem Crimpstempel und dem Positionierstück.

**Crimpbereich**

Der Bereich der Crimphülse, in dem die Crimpverbindung durch Druckverformung oder Druckumformung der Hülse um den Leiter herum ausgeführt ist.

**Crimphülse**

Eine Anschlusschülse, die einen oder mehrere Leiter aufnehmen kann und durch Anwendung eines Crimpwerkzeugs gecrimpt werden kann.

**Crimpverbindung**

Durch systematisches Verformen einer Crimphülse um abisolierte Leiter herum hergestellte, dauerhafte elektrische und mechanische Verbindung; Crimpverbindung siehe IEC 60352-2, 2a; 2b; 2c, DIN EN 60 352-2 (siehe auch Katalog „Werkzeuge“)

**Durchgangswiderstand**

Der elektrische Widerstand in einem gesteckten bzw. geschalteten Kontaktpaar, gemessen zwischen den Anschlusspunkten unter vorgeschriebenen Messbedingungen. Prüfungen nach ICE 60512-2, DIN EN 60 512-2

**Elektromagnetische Einflüsse**

Bei Steckverbindern werden unerwünschte elektromagnetische Einflüsse auf die zu verbindenden Leitungen bzw. auf die Umgebung durch Abschirmung verhindert.

**Gehäuse**

Teil eines Steckverbinders, in dem Kontakträger und Kontakte montiert sind. Es kann zur Verriegelung dienen.

**Grenztemperaturen**

Untere und obere Temperaturen, die nicht zu einer Schädigung der Werkstoffe führen; dazwischen liegt der Betriebstemperaturbereich.

- Untere Grenztemperatur: Die tiefste zulässige Temperatur, bei der ein Steckverbinder oder eine Steckvorrichtung noch betrieben werden darf.
- Obere Grenztemperatur: Die höchste zulässige Temperatur, bei der ein Steckverbinder oder eine Steckvorrichtung noch betrieben werden darf. Sie ist die Summe aus Eigenerwärmung (einschließlich Kontaktwärnung) und Umgebungstemperatur.

**Isolationswiderstand**

Widerstand der Isolierung zwischen zwei leitfähigen Teilen. Isoliervermögen eines Werkstoffes, der zwei benachbarte Kontakte oder einen Kontakt gegen Masse möglichst hochohmig trennt. Mess- und Prüfverfahren nach IEC 60512-2, 3a, DIN EN 60 512-2

**Isolierstoffgruppe**

Einteilung von Isolierstoffen entsprechend ihren CTI-Werten (CTI = Comparative Tracking Index / Vergleichszahl der Kriechwegbildung).

**Kompatible Steckverbinder**

Zwei Steckverbinder sind kompatibel, wenn sie mechanisch austauschbar und zusammensteckbar sind und den gleichen technischen Anforderungen entsprechen.

**Kontaktgröße**

Kennzeichnung zur Differenzierung der Kontakte nach folgendem Systemen

- a) Kennzeichnungssystem: Kennzeichnung des Kontaktes nach der maximal anschließbaren Leitergröße (AWG American Wire Gauge);

- b) Strombelastbarkeitssystem: Kennzeichnung des Kontaktes nach seiner maximalen Strombelastbarkeit.

- c) Querschnittssystem: Kennzeichnung des Kontaktes nach dem maximal anschließbaren Leiterquerschnitt. Leiterwiderstand.

**Kontaktmaterial**

Die Wahl des Kontaktmaterials – meist Kupfer oder Kupferlegierungen – hängt von den gewünschten Eigenschaften des Steckverbinders ab. Hierbei spielen Durchgangswiderstand; Steck- und Ziehkraften eine maßgebliche Rolle. Neben Stechkhäufigkeit und Umwelteinflüssen bestimmen diese auch die Art der Oberflächenüberzüge Nickel, Zinn, Gold, Silber, Palladium. Sie werden galvanisch oder walztechnisch aufgebracht.

**Kriechstrecken**

Kürzeste Entfernung zwischen spannungsführenden Teilen auf der Oberfläche von Isolierkörpern, sofern festgelegte Mindestmaße vorliegen (Kriechstreckenverlängerung). Die Abstände dienen der Sicherheit gegen Überschlagn. Sie werden in Abhängigkeit von der Reihenspannung, den Anwendungsbedingungen und den Eigenschaften des Isolierwerkstoffes festgelegt. Die unterschiedliche Kriechstromfestigkeit der Isolierstoffe ist bei der Festlegung der Kriechstrecken zu beachten (DIN VDE 0110-1.)

**Lebensdauer**

Anzahl der Steckzyklen, die noch nicht zum Durchrieb der leitenden Kontaktflächen führt und den Kontaktwiderstand nicht unzulässig erhöht. Mess- und Prüfverfahren nach IEC 60512-5, DIN EN 60512-5

**Luftstrecken**

Kürzeste, als Fadenmaß gemessene Entfernung zwischen zwei spannungsführenden Metallteilen in der Luft, nach DIN VDE 0110-1.

**Rechteck-Verbinder**

Steckverbinder mit vorwiegend rechteckiger Form des Steckgesichtes.

**Schaltleistung**

Die Schaltleistung einer Steckvorrichtung ist die Leistung, die die Steckvorrichtung unter festgelegten Bedingungen schalten kann.

**Spannungsfestigkeit**

Spannung, der ein Steckverbinder oder eine Steckvorrichtung bei vorgegebenen Bedingungen ohne Durchschlag oder Überschlagn widersteht. Die Spannungsfestigkeit liegt über der Nennspannung, sie dient zum Nachweis des Isoliervermögens des Steckverbinders.

**Steckverbinder**

Ein Bauelement, das es gestattet elektrische Leiter anzuschließen, und dazu bestimmt ist, mit einem passenden Gegenstück Verbindungen herzustellen und zu trennen. Steckverbinder sind Betriebsmittel, die bei bestimmungsgemäßer Verwendung (unter elektrischer Spannung) nicht gesteckt oder getrennt werden dürfen (im Gegensatz Steckverbinder mit Schaltleistung). Nach der Befestigung werden freie und feste Steckverbinder unterschieden. Der Steckverbinder besteht aus dem Steckverbindergehäuse und den Kontaktelementen. Das Steckverbindergehäuse enthält den Kontakteinsatz.

**Steckverbindung**

Eine elektrische Steckverbindung besteht aus zwei Steckverbindern, d. h. aus mindestens zwei Kontaktelementen. Alle weiteren Komponenten wie Gehäuse, Kontakträger, Kontakthalterung usw., erfüllen sekundäre Funktionen.

**Steckverbinder mit Schaltleistung**

Ein Bauelement, das bei bestimmungsgemäßer Verwendung unter elektrischer Spannung oder Last gesteckt oder getrennt wird. Der Schutzleiterkontakt muss während des Steckens vor- und während des Trennens naheilen (voreilender Kontakt).

**Steckzyklen**

Mechanisches Betätigen von Steckverbindern und Steckvorrichtungen durch Stecken und Ziehen. Ein Steckzyklus besteht aus je einem Steck- und Ziehvorgang.

**Überspannungskategorie**

Ein Zahlenwert, der eine Stehstoßspannung festlegt. Er werden die Überspannungskategorien I, II, III und IV verwendet.

**Verschmutzungsgrad**

Zahlenwert, der die erwartende Verschmutzung der Mikro-Umgebung angibt. Er werden die Verschmutzungsgrade 1, 2, 3 und 4 verwendet.

**Voreilender Kontakt**

Erfordert der Schaltungsaufbau, dass aus Schutzgründen, z. B. für Schutzleiter, ein oder mehrere Kontakte eines Steckverbinders beim Stecken zuerst Kontakt herstellen oder beim Ziehen als letzte getrennt werden, sind Steckverbinder mit voreilenden Kontakten (Stift bzw. Messer, Buchse oder Feder) zu verwenden.

**American Wire Gauge (AWG)**

System of numerical designations for wire sizes, based on specified ranges of cross-sectional areas. Starts with 4/0 (000) at the largest size, going to 3/0, 2/0, 1/0, 1, 2, and up to 40 and beyond for the smallest size. A step of one AWG number corresponds to a reduction of cross-sectional area of appr. 20 %.

**Attenuation**

A reduction of power. Occurs naturally when waves travel through lines, wave guides, or media such as air or water. Is produced additionally by imperfections in electrical or optical connections (attenuation in fibre optics), e. g. contact resistance, mismatch, etc.

**Bulkhead connector**

Connector designed to be inserted into a panel cutout from the rear of the panel, thus forming part of the barrier between two spaces. Back-mounted.

**Clearance**

The shortest distance in air between two conductive parts, see IEC 60664.

**Climatic stability**

General term describing the behavior of components under various climatic conditions, e. g. high and low temperatures, tropical climate, high humidity, moist heat, fungus, atmospheric conditions (industrial atmosphere), reduced air pressure, etc. Climatic conditions for test purposes are explained in IEC 60068, DIN 46 040.

**Connector**

A component which terminates conductors for the purpose of providing connection and disconnection to a suitable mating component which shall not be engaged or disengaged when live. Depending on the fastening to a cabinet, panel, rack etc. or a cable, they are classified as fixed or free connectors. A connector comprises one or more contacts and a housing which may have a separate connector insert and a separate outer housing or shell.

**Connector housing**

The part of a connector into which the insert and the contacts are assembled. It may function as part of the locking mechanism.

**Connector insert**

An insulating element designed to support and position contacts in a connector housing.

**Connector life**

The number of mating cycles prior to abrasion of the conductive contact surface and which does not result in a significant rise of the contact resistance. Tests according to test 9a of ICE 60512-5 / DIN EN 60512 Part 5.

**Contact**

The conductive element in a connector which mates with a corresponding element to provide an electrical path.

**Contact resistance**

The electrical resistance of a mated set of contacts under specified conditions. Tested according to tests 2a, 2b, 2c, of IEC 60 512 -2/ DIN EN 60 512-2.

**Contact size**

The designation used to differentiate one contact from another. It may be denoted by one of the following numbering systems:

- numbering system: assigned numbers used to denote the size of the contact and its related conductor accommodation (e. g. in AWG units),
- current rating system: the related current-carrying capacity is used to denote the size of the contact,
- cross-sectional area system: reference is made to the cross-sectional area of the maximum conductor accommodation to denote the size of the contact, e. g. in mm<sup>2</sup>.

**Creepage distance**

The shortest distance along the surface of the insulating material between two conductive parts. The longer the distance, the less the risk of arc damage or tracking. Minimum creepage distances are specified according to the rated voltage and the applicable pollution degree and Comperative Tracking Index.

**Crimped connection**

A solderless connection made by crimping. IEC 60352-2 / DIN IEC 60352 Part 2.

**Crimping die**

That part of a crimping tool which forms the crimp(s) and usually incorporates the crimp anvil(s) and the crimp indenter(s).

**Derating curve**

The method for determining derating is specified in IEC 60 512-3. Here the combination of ambient temperature (Tu) and the current (I) leading to the same maximum allowable temperature (Tb) at the hottest point of the connector are plotted.

**DIN**

Deutsches Institut für Normung. A German standards organization.

**Electromagnetic interference (EMI)**

General term describing the undesirable effects of the immission or emission of radio frequency fields. In connectors electromagnetic interference is prevented by shielding. Shielded connectors normally provide means to connect the screens of attached cables.

**Funnel entry (restricted entry C146 D series)**

Flared or widened entrance to a conductor barrel permitting easier insertion of the conductor.

**Insertion or withdrawal force**

The force required to fully insert or withdraw a set of mated connectors without the effect of coupling, locking or similar devices. The insertion force is usually greater than the withdrawal force.

**Insulation grip**

The area of a crimp contact that has been reshaped around the insulation of the conductor by compression during the crimping operation.

**Insulation resistance**

The resistance of the insulation between two conductive elements, in particular, the resistance between two contacts or between a contact and a metallic housing or shield. Tested according to test 3a of IEC 60512-2 / DIN IEC 60512 Part 2.

**Intermateable**

Two connectors are intermateable when they are capable of being connected electrically and mechanically but without regard to their performance and intermountability.

**Locator**

In a crimping tool the device used for positioning a crimp contact or terminal end.

**Locking lever**

A mechanical locking device operated by actuating a lever, designed to hold two mated connectors together. Typically the lever can only be fully locked if the two connectors are correctly mated.

**Mating cycle**

One mating cycle comprises one insertion and one withdrawal operation. Term used in the definition of connector life.

**Material group**

Classification of insulation materials according to their CTI values (CTI = Comperative Tracking Index)

**Overvoltage category**

A numeral defining a transient overvoltage condition. Overvoltage categories I, II, III and IV are used.

**Connector with braking capacity (CBC)**

A component which may be engaged or disengaged in normal use, when live or under load. Note: In the sense of this document the term - live- is used if contacts are under voltage not necessarily with a current flowing across the contacts. The term - load - is used if a current is flowing across the contacts.

**Rated current**

A current value assigned by the manufacturer which the connector or PSD can carry continuously (without interruption) and simultaneously through all its contacts wired with the largest conductor preferably at an ambient temperature of 40 °C without the upper temperature being exceeded.

**Shield, shielding**

Shielding of internal or external electric fields by means of a plane with a uniform electric potential, formed by metal shells or metallic layers on the inside or outside of plastic shells. The shield is normally connected to the shielding braid of the cable and/or chassis ground.

**Terminal block**

An assembly of terminals in a housing or body of insulating material to facilitate interconnection between multiple conductors. Also called terminal strip or barrier blocks if the terminals are separated by an insulation barrier.

**Wire range**

The range of wire cross sections which is compatible with the dimensions the terminals of the contact (wire barrel). The wire range is expressed in mm<sup>2</sup> or in AWG numbers.

**Gestanzte Crimphülsen Serie C146 Abisolierlängen für anzuschließenden Leiter**

**Stamped crimp contacts series C146, stripping length**

Anschlussquerschnitt [mm <sup>2</sup> ] Termination crimp [mm <sup>2</sup> ]	Leiterquerschnitt Wire gauge		Isolierungsdurchmesser der Leitung [mm] Insulation diameter of the wire [mm]	Mindestabisolierlänge mit Toleranz [mm] Min. stripping length [mm]	Kontakt Art.-Nr. Contact part No.	in Serie Series
	mm <sup>2</sup>	AWG				
0,09 - 0,25	0,09 - 0,25	28 - 24	0,7 - 1,6	2,3 + 0,4	N01 010 0130 (2) N02 010 0130 (2)	C146M C146M
0,14 - 0,5	0,14	26	1,0 - 2,0	3,0 + 0,5	N01 016 0003 N02 016 0003	C146D/M C146D/M
	0,25	24-22				
	0,5	20				
0,25 - 0,5	0,25	24-22	1,6 - 2,0	2,3 + 0,4	N01 010 0131 (2) N02 010 0131 (2)	C146M C146M
	0,5	20				
0,5 - 1,5	0,5	20	1,8 - 2,8	3,5 + 1,0	N01 016 0002 N02 016 0002 N01 016 0015 N02 016 0015 N01 025 0001 N02 025 0001 N01 025 0007	C146D/M C146D/M C146D C146D C146E/M C146E/M/S C146S
	0,75	20 - 18				
	1,0	18 - 16				
	1,5	16 - 15				
1,5 - 2,5	1,5	16 - 15	2,5 - 3,5	3,5 + 1,0	N01 016 0005 N02 016 0005 N01 016 0016 N02 016 0016 N01 025 0010 N02 025 0010 N01 025 0008	C146D/M C146D/M C146D C146D C146E/M C146E/M/S C146S
	2,5	14				
2,5 - 4,0	2,5	14	3,3 - 4,2	3,5 + 1,0	N01 025 0043 N02 025 0043	C146M C146M
	4,0	12				

**Gedrehte Crimpkontakte Serie C146 Abisolierlängen für anzuschließenden Leiter**

**Turned crimp contacts series C146, stripping length**

Anschlussquerschnitt [mm <sup>2</sup> ] Termination crimp [mm <sup>2</sup> ]	1,6 (Kontakt ohne Clip) (Contact without clip)			2,5 (Kontakt mit Clip) (Contact with clip)			2,5 (Kontakt ohne Clip) (Contact without clip)			3,6 (Kontakt mit Clip) (Contact with clip)		
	Mind.abisolierlänge+Toleranz [mm] Min. stripping length+tolerance[mm]	Kontakt Art Nr. Contact part No.	in Serie Series	Mind.abisolierlänge+Toleranz [mm] Min. stripping length+tolerance[mm]	Kontakt Art Nr. Contact part No.	in Serie Series	Mind.abisolierlänge+Toleranz [mm] Min. stripping length+tolerance[mm]	Kontakt Art Nr. Contact part No.	in Serie Series	Mind.abisolierlänge+Toleranz [mm] Min. stripping length+tolerance[mm]	Kontakt Art Nr. Contact part No.	in Serie Series
	0,14 - 0,37	8 + 1	N01 016 0024 N02 016 0024	C146 D/DD/M								
0,5	8 + 1	N01 016 0025 N02 016 0025	C146 D/DD/M	7 + 1	N01 025 0029 N02 025 0029	C146 M	7 + 1	N01 025 0035 N02 025 0035	C146 E/EE			
0,75 - 1,0	8 + 1	N01 016 0026 N02 016 0026	C146 D/DD/M	7 + 1	N01 025 0030 N02 025 0030	C146 M	7 + 1	N01 025 0036 N02 025 0036	C146 E/EE			
1,5	8 + 1	N01 016 0027 N02 016 0027	C146 D/DD/M	7 + 1	N01 025 0031 N02 025 0031	C146 M	7 + 1	N01 025 0037 N02 025 0037	C146 E/EE	10 + 1	N01 036 0004 N02 036 0004	C146 M
2,5	6 + 1	N01 016 0028 N02 016 0028	C146 D/DD/M	7 + 1	N01 025 0032 N02 025 0032	C146 M	7 + 1	N01 025 0038 N02 025 0038	C146 E/EE	10 + 1	N01 036 0005 N02 036 0005	C146 M
4,0				7 + 1	N01 025 0033 N02 025 0033	C146 M	7 + 1	N01 025 0039 N02 025 0039	C146 E/EE	10 + 1	N01 036 0001 N02 036 0001	C146 M
6,0										10 + 1	N01 036 0002 N02 036 0002	C146 M
10,0										10 + 1	N01 036 0003 N02 036 0003	C146 M

**Zeitersparnis durch den Einsatz von gestanzten Kontakten**  
*Time saving through the introduction of stamped contacts*

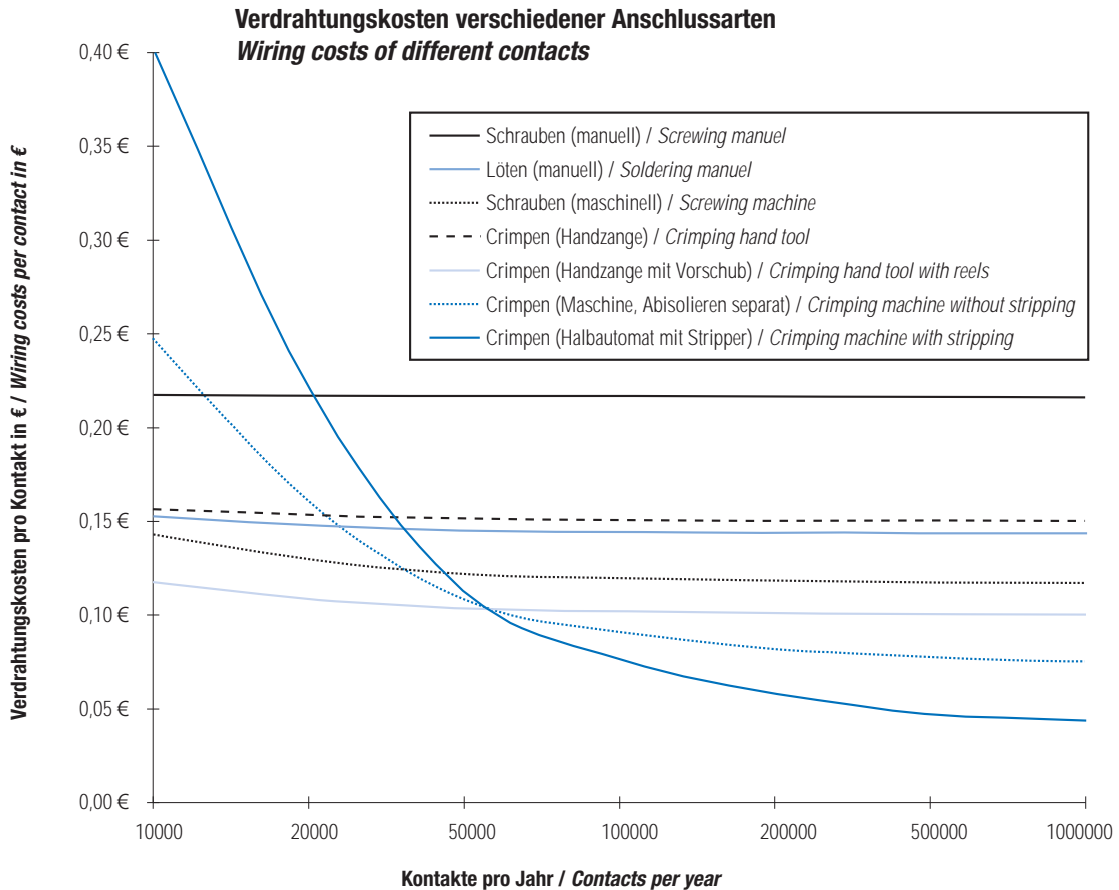

**Break Even bei**  
**ca. 60.000 Kontakten pro Jahr / contacts per year**

<b>Rahmenbedingungen / General conditions:</b>	
<b>Laufzeit (Abschreibung) / Maturity (Depreciation)</b>	<b>5 Jahre / years</b>
<b>Zins / Interest</b>	<b>8%</b>
<b>Wartung / Maintenance</b>	<b>5%</b>
<b>Stundenlohn Bediener / Hourly wages</b>	<b>20 €</b>

**Unverbindliche Angaben beruhen auf uns vorliegenden Erfahrungswerten.**  
*Non binding declarations are based on experienced values.*



Bestellnummer / Part Number  
FM 0300 146

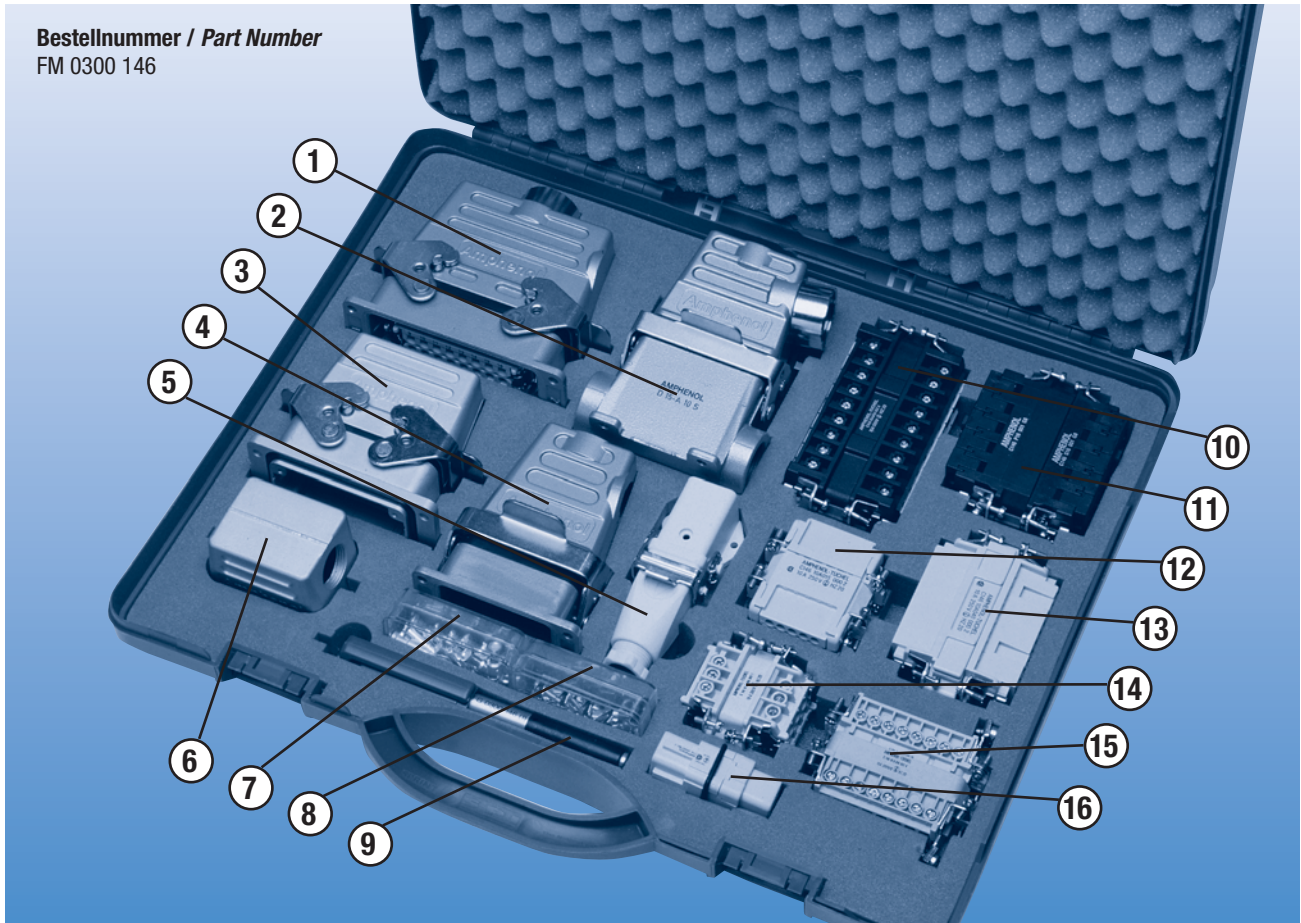

- ① Steckverbinder Serie C 146 E 16 pol
- ② Steckverbinder Serie C 146 A 10 pol
- ③ EMV Gehäuse
- ④ Standard Gehäuse hohe Bauform ohne Stutzen
- ⑤ Steckverbinder Serie C 146 A 3 pol
- ⑥ EMV Tüllengehäuse
- ⑦ Gedrehte Crimpkontakte
- ⑧ Gestanzte Crimpkontakte
- ⑨ Lösewerkzeug für 1,6 mm Kontakte
- ⑩ Kontakteinsätze Serie C 146 HvE 16 pol
- ⑪ Rahmen und Module Serie C 146 M
- ⑫ Kontakteinsätze Serie C 146 D 15 pol (für gedrehte Kontakte)
- ⑬ Kontakteinsätze Serie C 146 D 40 pol (für gestanzte Kontakte)
- ⑭ Kontakteinsätze Serie C 146 E 6 pol
- ⑮ Kontakteinsätze Serie C 146 A 16 pol
- ⑯ Kontakteinsätze Serie C 146 D 7 pol

- ① Connector series C 146 E 16 contacts
- ② Connector series C 146 A 10 contacts
- ③ EMC housing
- ④ Standard housing high profile without stud
- ⑤ Connector series C 146 A 3 contacts
- ⑥ EMC hood
- ⑦ Turned crimp contacts
- ⑧ Stamped crimp contacts
- ⑨ Removal tool for 1,6 mm contacts
- ⑩ Contact insert series C 146 HvE 16 contacts
- ⑪ Frames and modules series C 146 M
- ⑫ Contact inserts series C 146 D 15 contacts (for turned contacts)
- ⑬ Contact inserts series C 146 D 40 contacts (for stamped contacts)
- ⑭ Contact inserts series C 146 E 6 contacts
- ⑮ Contact inserts series C 146 A 16 contacts
- ⑯ Contact inserts series C 146 D 7 contacts



**Bestellnummer / Part Number**

FM 0500 146

FM 0501 146 (ohne / without TB0200 146)

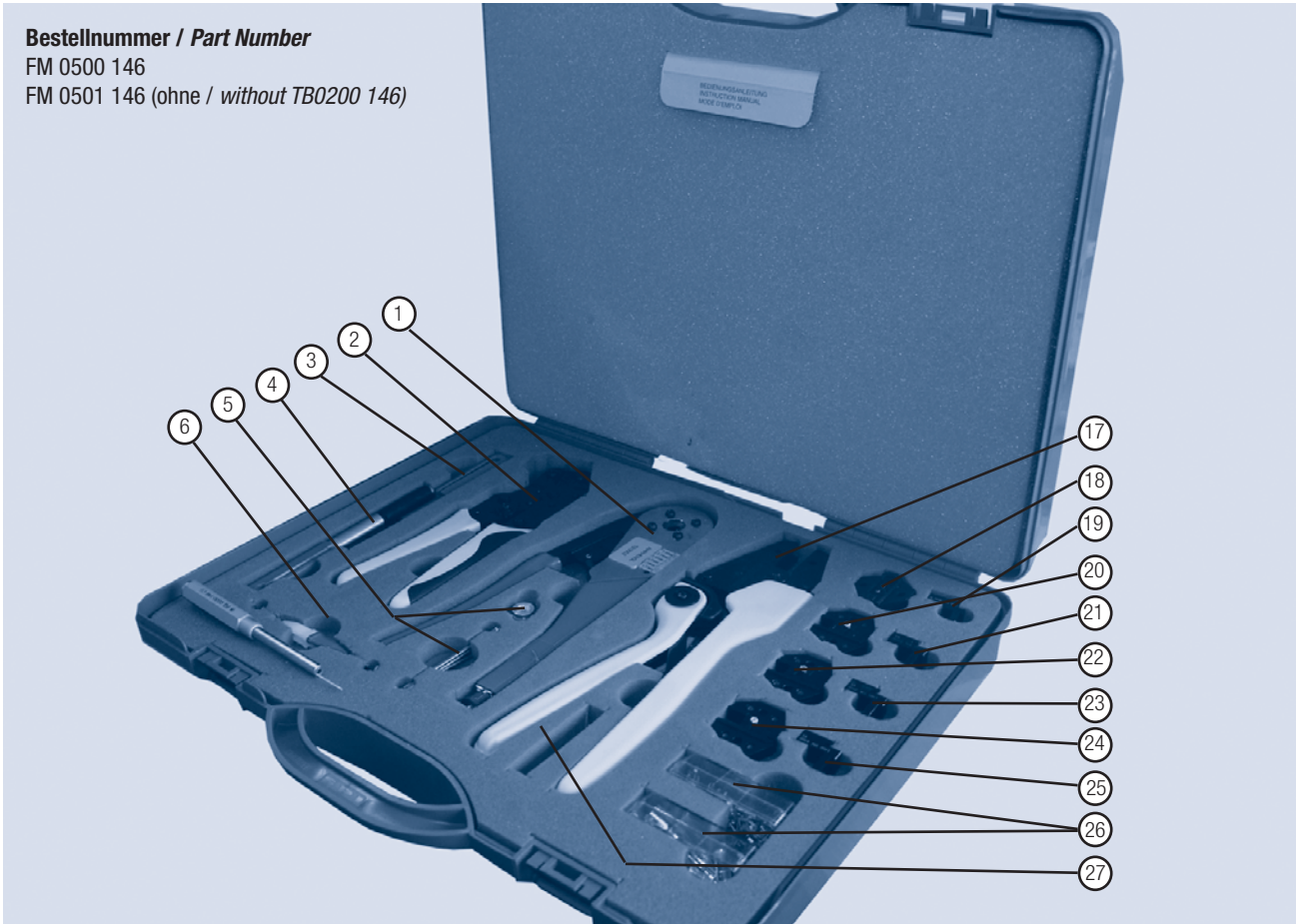

Bezeichnung	Description	Katalog „Werkzeuge“ / Catalogue „Tools“	
		Bestell-Nr./ Part No.	Seite / Page
1 4 - Kerb Crimpzange	1 4 - Indent hand crimping tool	TB 0200 146	9
2 Service Hand Crimpwerkzeug	2 Service hand crimping tool	TA 0200 146	12
3 Lösewerkzeug	3 Removal tool	FG 0300 146 1	17
4 Lösewerkzeug	4 Removal tool	FG 0300 146 3	17
5 Zubehör	5 Accessories	TB 0200 146	9
6 Lösewerkzeug	6 Removal tool	17D 438 SP	17
7 Zubehör	7 Accessories	TA 0000	5
8 Kontaktbehältnis	8 Contact container		
9 Kontaktaufnahme	9 Contact locator	TA 0001 146 0001	7
10 Crimpbacken	10 Crimping dies	TA 0000 202	7
11 Kontaktaufnahme	11 Contact locator	TA 0007 146 0003	7
12 Crimpbacken	12 Crimping dies	TA 0000 141	7
13 Kontaktaufnahme	13 Contact locator	TA 0002 146 0001	7
14 Crimpbacken	14 Crimping dies	TA 0000 163	7
15 Kontaktaufnahme	15 Contact locator	TA 0010 146 0004	7
16 Crimpbacken	16 Crimping dies	TA 0000124	7
17 Handcrimpwerkzeug	17 Hand crimping tool	TA 0000	5

Bestell Nr. / Part No.	Seite / Page	Bestell Nr. / Part No.	Seite / Page	Bestell Nr. / Part No.	Seite / Page	Bestell Nr. / Part No.	Seite / Page
17D 438 SP	61, 80	C146 10A025 505 2	18	C146 10B018 500 10	46	C146 10F010 090 1	130, 131
17 DM 537 401	73, 179	C146 10A032 500 10	46	C146 10B024 000 1	40, 42	C146 10F010 500 1	130
17 DM 537 405	73, 179	C146 10A040 000 2	16	C146 10B024 000 9	26	C146 10F010 500 2	130
17 DM 537 421	73, 179	C146 10A040 009 2	16	C146 10B024 002 1	40, 42	C146 10F010 501 2	130
17 DM 537 425	73, 179	C146 10A040 060 2	16	C146 10B024 005 1	42	C146 10F010 502 1	132
C146 10A003 002 4	84	C146 10A040 500 2	16	C146 10B024 102 1	40, 42	C146 10F010 502 2	132
C146 10A003 102 3	96	C146 10A042 000 9	26	C146 10B024 500 1	40, 42	C146 10F010 503 2	132
C146 10A004 002 4	84	C146 10A046 500 10	46	C146 10B024 505 1	42	C146 10F010 504 1	134
C146 10A006 000 1	34	C146 10A057 000 6	104	C146 10B024 810 1	52	C146 10F010 504 2	134
C146 10A006 002 1	34	C146 10A057 801 6	104	C146 10B025 000 2	14, 18	C146 10F010 505 2	134
C146 10A006 102 1	34	C146 10A064 000 2	20, 22	C146 10B025 005 2	18	C146 10F010 506 1	132
C146 10A006 102 3	97	C146 10A064 005 2	22	C146 10B025 009 2	14	C146 10F010 506 2	132
C146 10A006 102 5	91	C146 10A064 009 2	20	C146 10B025 060 2	14	C146 10F010 507 2	132
C146 10A006 500 1	34	C146 10A064 060 2	20	C146 10B025 500 2	14, 18	C146 10F010 508 2	134
C146 10A006 810 1	52	C146 10A064 500 2	20, 22	C146 10B032 500 10	46	C146 10F010 509 2	134
C146 10A007 000 2	10	C146 10A064 505 2	22	C146 10B040 000 2	16	C146 10F010 600 1	130
C146 10A007 500 2	10	C146 10A072 000 9	26	C146 10B040 009 2	16	C146 10F010 600 2	130
C146 10A008 000 2	10	C146 10A108 000 9	26, 27	C146 10B040 060 2	16	C146 10F010 601 2	130
C146 10A008 500 2	10	C146 10A108 005 9	27	C146 10B040 500 2	16	C146 10F010 602 1	132
C146 10A010 000 1	36	C146 10B003 002 4	84	C146 10B042 000 9	26	C146 10F010 602 2	132
C146 10A010 002 1	36	C146 10B003 102 3	96	C146 10B046 500 10	46	C146 10F010 603 2	132
C146 10A010 002 4	85	C146 10B004 002 4	84	C146 10B057 000 6	104	C146 10F010 604 1	134
C146 10A010 102 1	36	C146 10B006 000 1	34	C146 10B057 801 6	104	C146 10F010 604 2	134
C146 10A010 102 3	98, 100	C146 10B006 002 1	34	C146 10B064 000 2	20, 22	C146 10F010 605 2	134
C146 10A010 102 4	85	C146 10B006 102 1	34	C146 10B064 005 2	22	C146 10F010 606 1	132
C146 10A010 104 3	100	C146 10B006 102 3	97	C146 10B064 009 2	20	C146 10F010 606 2	132
C146 10A010 500 1	36	C146 10B006 102 5	91	C146 10B064 060 2	20	C146 10F010 607 2	132
C146 10A010 500 10	46	C146 10B006 500 1	34	C146 10B064 500 2	20, 22	C146 10F010 608 2	134
C146 10A010 810 1	52	C146 10B006 810 1	52	C146 10B064 505 2	22	C146 10F010 609 2	134
C146 10A015 000 2	12	C146 10B007 000 2	10	C146 10B072 000 9	26	C146 10F010 802 1	132
C146 10A015 009 2	12	C146 10B007 500 2	10	C146 10B108 000 9	26, 27	C146 10F010 802 2	132
C146 10A015 060 2	12	C146 10B008 000 2	10	C146 10B108 005 9	27	C146 10F010 803 2	132
C146 10A015 500 2	12	C146 10B008 500 2	10	C146 10F003 000 4	110, 111	C146 10F010 804 1	134
C146 10A016 000 1	38	C146 10B010 000 1	36	C146 10F003 004 4	110, 111	C146 10F010 804 2	134
C146 10A016 002 1	38	C146 10B010 002 1	36	C146 10F003 500 4	110	C146 10F010 805 2	134
C146 10A016 002 3	99	C146 10B010 002 4	85	C146 10F006 000 1	126, 127	C146 10F010 806 1	132
C146 10A016 002 4	86, 87	C146 10B010 102 1	36	C146 10F006 003 1	126, 127	C146 10F010 806 2	132
C146 10A016 004 4	87	C146 10B010 102 3	98, 100	C146 10F006 500 1	128	C146 10F010 807 2	132
C146 10A016 102 1	38	C146 10B010 102 4	85	C146 10F006 502 1	128	C146 10F015 000 2	114, 115
C146 10A016 102 3	99, 100	C146 10B010 104 3	100	C146 10F006 502 2	128	C146 10F015 003 2	114, 115
C146 10A016 102 4	86, 87	C146 10B010 500 1	36	C146 10F006 503 2	128	C146 10F015 500 2	116
C146 10A016 104 3	100	C146 10B010 500 10	46	C146 10F006 506 1	128	C146 10F015 501 2	116
C146 10A016 104 4	87	C146 10B010 810 1	52	C146 10F006 506 2	128	C146 10F015 600 2	116
C146 10A016 500 1	38	C146 10B015 000 2	12	C146 10F006 507 2	128	C146 10F015 601 2	116
C146 10A016 810 1	52	C146 10B015 009 2	12	C146 10F006 600 1	128	C146 10F015 606 2	116
C146 10A018 500 10	46	C146 10B015 060 2	12	C146 10F006 602 2	128	C146 10F015 607 2	116
C146 10A024 000 1	40, 42	C146 10B015 500 2	12	C146 10F006 603 2	128	C146 10F015 806 2	116
C146 10A024 000 9	26	C146 10B016 000 1	38	C146 10F006 606 1	128	C146 10F015 807 2	116
C146 10A024 002 1	40, 42	C146 10B016 002 1	38	C146 10F006 606 2	128	C146 10F016 000 1	138, 139
C146 10A024 005 1	42	C146 10B016 002 3	99	C146 10F006 607 2	128	C146 10F016 001 1	140, 141
C146 10A024 102 1	40, 42	C146 10B016 002 4	86, 87	C146 10F006 802 2	128	C146 10F016 002 1	142, 143
C146 10A024 500 1	40, 42	C146 10B016 004 4	87	C146 10F006 803 2	128	C146 10F016 003 1	140, 141
C146 10A024 505 1	42	C146 10B016 102 1	38	C146 10F006 806 1	128	C146 10F016 500 1	138
C146 10A024 810 1	52	C146 10B016 102 3	99, 100	C146 10F006 806 2	128	C146 10F016 502 1	140
C146 10A025 000 2	14, 18	C146 10B016 102 4	86, 87	C146 10F006 807 2	128	C146 10F016 504 1	142
C146 10A025 005 2	18	C146 10B016 104 3	100	C146 10F010 000 1	130, 131	C146 10F016 506 1	140
C146 10A025 009 2	14	C146 10B016 104 4	87	C146 10F010 001 1	132, 133	C146 10F016 508 2	142
C146 10A025 060 2	14	C146 10B016 500 1	38	C146 10F010 002 1	134, 135	C146 10F016 509 2	142
C146 10A025 500 2	14, 18	C146 10B016 810 1	52	C146 10F010 003 1	132, 133	C146 10F016 600 1	138

Bestell Nr. / Part No.	Seite / Page	Bestell Nr. / Part No.	Seite / Page	Bestell Nr. / Part No.	Seite / Page	Bestell Nr. / Part No.	Seite / Page
C146 10F016 602 1	140	C146 10F040 605 2	142	C146 10G010 506 8	132	C146 10G016 606 8	140
C146 10F016 604 1	142	C146 10F040 606 2	140	C146 10G010 507 1	132	C146 10G016 607 1	140
C146 10F016 606 1	140	C146 10F040 607 2	140	C146 10G010 507 8	132	C146 10G016 607 8	140
C146 10F016 608 2	142	C146 10F040 802 2	140	C146 10G010 550 8	130	C146 10G016 802 1	138
C146 10F016 609 2	142	C146 10F040 803 2	140	C146 10G010 600 1	130	C146 10G016 802 8	138
C146 10F016 802 1	140	C146 10F040 804 2	142	C146 10G010 600 4	114	C146 10G016 803 1	138
C146 10F016 804 1	142	C146 10F040 805 2	142	C146 10G010 600 8	130	C146 10G016 803 8	138
C146 10F016 806 1	140	C146 10F040 806 2	140	C146 10G010 601 1	130	C146 10G016 804 1	140
C146 10F024 000 1	146, 147	C146 10F040 807 2	140	C146 10G010 601 4	114	C146 10G016 804 4	118
C146 10F024 000 3	154, 155	C146 10F064 500 2	146	C146 10G010 601 8	130	C146 10G016 804 8	140
C146 10F024 001 1	148, 149	C146 10F064 501 2	146	C146 10G010 602 1	134	C146 10G016 805 1	140
C146 10F024 002 1	150, 151	C146 10F064 502 2	148	C146 10G010 602 8	134	C146 10G016 805 4	118
C146 10F024 003 1	148, 149	C146 10F064 503 2	148	C146 10G010 603 1	134	C146 10G016 805 8	140
C146 10F024 500 1	146	C146 10F064 504 2	150	C146 10G010 603 8	134	C146 10G016 902 8	144
C146 10F024 500 3	154	C146 10F064 505 2	150	C146 10G010 606 1	132	C146 10G024 500 1	146
C146 10F024 502 1	148	C146 10F064 506 2	148	C146 10G010 606 8	132	C146 10G024 500 3	154
C146 10F024 504 1	150	C146 10F064 507 2	148	C146 10G010 607 1	132	C146 10G024 500 8	146
C146 10F024 506 1	148	C146 10F064 600 2	146	C146 10G010 607 8	132	C146 10G024 501 1	146
C146 10F024 508 2	150	C146 10F064 601 2	146	C146 10G010 650 8	130	C146 10G024 501 8	146
C146 10F024 509 2	150	C146 10F064 602 2	148	C146 10G010 802 1	130	C146 10G024 502 1	150
C146 10F024 600 1	146	C146 10F064 603 2	148	C146 10G010 802 8	130	C146 10G024 502 8	150
C146 10F024 600 3	154	C146 10F064 604 2	150	C146 10G010 803 1	130	C146 10G024 503 1	150
C146 10F024 602 1	148	C146 10F064 605 2	150	C146 10G010 803 8	130	C146 10G024 503 8	150
C146 10F024 604 1	150	C146 10F064 606 2	148	C146 10G010 804 1	132	C146 10G024 506 1	148
C146 10F024 606 1	148	C146 10F064 607 2	148	C146 10G010 804 4	114	C146 10G024 506 8	148
C146 10F024 608 2	150	C146 10F064 802 2	148	C146 10G010 804 8	132	C146 10G024 507 1	148
C146 10F024 609 2	150	C146 10F064 803 2	148	C146 10G010 805 1	132	C146 10G024 507 8	148
C146 10F024 802 1	148	C146 10F064 804 2	150	C146 10G010 805 4	114	C146 10G024 600 1	146
C146 10F024 804 1	150	C146 10F064 805 2	150	C146 10G010 805 8	132	C146 10G024 600 3	154
C146 10F024 806 1	148	C146 10F064 806 2	148	C146 10G010 902 8	136	C146 10G024 600 8	146
C146 10F025 000 2	118, 119	C146 10F064 807 2	148	C146 10G015 500 2	114	C146 10G024 601 1	146
C146 10F025 003 2	118, 119	C146 10G003 500 4	110	C146 10G015 501 2	114	C146 10G024 601 8	146
C146 10F025 500 2	120	C146 10G003 600 4	110	C146 10G015 600 2	114	C146 10G024 602 1	150
C146 10F025 501 2	120	C146 10G003 804 4	110	C146 10G015 601 2	114	C146 10G024 602 8	150
C146 10F025 600 2	120	C146 10G006 500 1	126	C146 10G015 804 2	114	C146 10G024 603 1	150
C146 10F025 601 2	120	C146 10G006 501 1	126	C146 10G016 500 1	138	C146 10G024 603 8	150
C146 10F025 606 2	120	C146 10G006 506 8	126	C146 10G016 500 4	118	C146 10G024 606 1	148
C146 10F025 607 2	120	C146 10G006 507 8	126	C146 10G016 500 8	138	C146 10G024 606 8	148
C146 10F025 806 2	120	C146 10G006 556 8	126	C146 10G016 501 1	138	C146 10G024 607 1	148
C146 10F025 807 2	120	C146 10G006 600 1	126	C146 10G016 501 4	118	C146 10G024 607 8	148
C146 10F032 000 4	124, 125	C146 10G006 601 1	126	C146 10G016 501 8	138	C146 10G024 802 1	146
C146 10F032 002 4	124, 125	C146 10G006 606 8	126	C146 10G016 502 1	142	C146 10G024 802 3	154
C146 10F032 500 4	124	C146 10G006 607 8	126	C146 10G016 502 8	142	C146 10G024 802 8	146
C146 10F032 501 4	124	C146 10G006 656 8	126	C146 10G016 503 1	142	C146 10G024 803 1	146
C146 10F032 600 4	124	C146 10G006 804 1	126	C146 10G016 503 8	142	C146 10G024 803 8	146
C146 10F032 601 4	124	C146 10G006 804 8	126	C146 10G016 506 1	140	C146 10G024 804 1	148
C146 10F040 500 2	138	C146 10G006 805 1	126	C146 10G016 506 8	140	C146 10G024 804 8	148
C146 10F040 501 2	138	C146 10G006 805 8	126	C146 10G016 507 1	140	C146 10G024 805 1	148
C146 10F040 502 2	140	C146 10G010 500 1	130	C146 10G016 507 8	140	C146 10G024 805 8	148
C146 10F040 503 2	140	C146 10G010 500 4	114	C146 10G016 600 1	138	C146 10G024 903 8	152
C146 10F040 504 2	142	C146 10G010 500 8	130	C146 10G016 600 4	118	C146 10G024 908 8	152
C146 10F040 505 2	142	C146 10G010 501 1	130	C146 10G016 600 8	138	C146 10G025 500 2	118
C146 10F040 506 2	140	C146 10G010 501 4	114	C146 10G016 601 1	138	C146 10G025 501 2	118
C146 10F040 507 2	140	C146 10G010 501 8	130	C146 10G016 601 8	138	C146 10G025 600 2	118
C146 10F040 600 2	138	C146 10G010 502 1	134	C146 10G016 602 1	142	C146 10G025 601 2	118
C146 10F040 601 2	138	C146 10G010 502 8	134	C146 10G016 602 8	142	C146 10G025 804 2	118
C146 10F040 602 2	140	C146 10G010 503 1	134	C146 10G016 603 1	142	C146 10G032 500 4	122
C146 10F040 603 2	140	C146 10G010 503 8	134	C146 10G016 603 8	142	C146 10G032 501 4	122
C146 10F040 604 2	142	C146 10G010 506 1	132	C146 10G016 606 1	140	C146 10G032 600 4	122

Bestell Nr. / Part No.	Seite / Page	Bestell Nr. / Part No.	Seite / Page	Bestell Nr. / Part No.	Seite / Page	Bestell Nr. / Part No.	Seite / Page
C146 10G032 601 4	122	C146 10N010 604 2	135	C146 10N016 600 2	139	C146 10N024 604 2	151
C146 10N003 500 4	111	C146 10N010 605 1	135	C146 10N016 601 2	139	C146 10N024 605 2	151
C146 10N006 502 1	129	C146 10N010 605 2	135	C146 10N016 602 1	141	C146 10N024 606 1	149
C146 10N006 502 2	129	C146 10N010 606 1	133	C146 10N016 602 2	141	C146 10N024 606 2	149
C146 10N006 503 1	129	C146 10N010 606 2	133	C146 10N016 603 2	141	C146 10N024 607 2	149
C146 10N006 503 2	129	C146 10N010 607 1	133	C146 10N016 604 1	143	C146 10N024 608 1	151
C146 10N006 506 1	129	C146 10N010 607 2	133	C146 10N016 604 2	143	C146 10N024 608 2	151
C146 10N006 506 2	129	C146 10N010 608 1	135	C146 10N016 605 2	143	C146 10N024 609 2	151
C146 10N006 507 1	129	C146 10N010 608 2	135	C146 10N016 606 1	141	C146 10N024 700 1	147
C146 10N006 507 2	129	C146 10N010 609 1	135	C146 10N016 606 2	141	C146 10N024 700 2	147
C146 10N006 602 1	129	C146 10N010 609 2	135	C146 10N016 607 2	141	C146 10N024 701 2	147
C146 10N006 602 2	129	C146 10N010 700 1	131	C146 10N016 608 1	143	C146 10N024 702 1	149
C146 10N006 603 1	129	C146 10N010 701 1	131	C146 10N016 608 2	143	C146 10N024 702 2	149
C146 10N006 603 2	129	C146 10N010 702 1	133	C146 10N016 609 2	143	C146 10N024 703 2	149
C146 10N006 606 1	129	C146 10N010 703 1	133	C146 10N016 700 1	139	C146 10N024 708 1	149
C146 10N006 606 2	129	C146 10N010 708 1	133	C146 10N016 700 2	139	C146 10N024 708 2	149
C146 10N006 607 1	129	C146 10N010 709 1	133	C146 10N016 701 2	139	C146 10N024 709 2	149
C146 10N006 607 2	129	C146 10N010 802 1	133	C146 10N016 702 1	141	C146 10N024 802 1	149
C146 10N006 702 1	129	C146 10N010 802 2	133	C146 10N016 702 2	141	C146 10N024 802 2	149
C146 10N006 703 1	129	C146 10N010 803 1	133	C146 10N016 703 2	141	C146 10N024 803 2	149
C146 10N006 708 1	129	C146 10N010 803 2	133	C146 10N016 708 1	141	C146 10N024 804 1	151
C146 10N006 709 1	129	C146 10N010 804 1	135	C146 10N016 708 2	141	C146 10N024 804 2	151
C146 10N006 802 1	129	C146 10N010 804 2	135	C146 10N016 709 2	141	C146 10N024 805 2	151
C146 10N006 802 2	129	C146 10N010 805 1	135	C146 10N016 802 1	141	C146 10N024 806 1	149
C146 10N006 803 1	129	C146 10N010 805 2	135	C146 10N016 802 2	141	C146 10N024 806 2	149
C146 10N006 803 2	129	C146 10N010 806 1	133	C146 10N016 803 2	141	C146 10N024 807 2	149
C146 10N006 806 1	129	C146 10N010 806 2	133	C146 10N016 804 1	143	C146 10N024 808 1	151
C146 10N006 806 2	129	C146 10N010 807 1	133	C146 10N016 804 2	143	C146 10N024 808 2	151
C146 10N006 807 1	129	C146 10N010 807 2	133	C146 10N016 805 2	143	C146 10N024 809 2	151
C146 10N006 807 2	129	C146 10N010 808 1	135	C146 10N016 806 1	141	C146 10N025 500 2	121
C146 10N010 500 1	131	C146 10N010 809 1	135	C146 10N016 806 2	141	C146 10N025 501 2	121
C146 10N010 500 2	131	C146 10N015 500 2	117	C146 10N016 807 2	141	C146 10N025 600 2	121
C146 10N010 501 1	131	C146 10N015 501 2	117	C146 10N016 808 1	143	C146 10N025 601 2	121
C146 10N010 501 2	131	C146 10N015 600 2	117	C146 10N016 808 2	143	C146 10N025 606 2	121
C146 10N010 502 1	133	C146 10N015 601 2	117	C146 10N016 809 2	143	C146 10N025 607 2	121
C146 10N010 502 2	133	C146 10N015 606 2	117	C146 10N024 500 1	147	C146 10N025 702 2	121
C146 10N010 503 1	133	C146 10N015 607 2	117	C146 10N024 500 2	147	C146 10N025 703 2	121
C146 10N010 503 2	133	C146 10N015 702 2	117	C146 10N024 500 3	155	C146 10N025 708 2	121
C146 10N010 504 1	135	C146 10N015 703 2	117	C146 10N024 501 2	147	C146 10N025 709 2	121
C146 10N010 504 2	135	C146 10N015 708 2	117	C146 10N024 502 1	149	C146 10N025 806 2	121
C146 10N010 505 1	135	C146 10N015 709 2	117	C146 10N024 502 2	149	C146 10N025 807 2	121
C146 10N010 505 2	135	C146 10N015 806 2	117	C146 10N024 503 2	149	C146 10N032 500 4	125
C146 10N010 506 1	133	C146 10N015 807 2	117	C146 10N024 504 1	151	C146 10N032 501 4	125
C146 10N010 506 2	133	C146 10N016 500 1	139	C146 10N024 504 2	151	C146 10N032 550 4	125
C146 10N010 507 1	133	C146 10N016 500 2	139	C146 10N024 505 2	151	C146 10N032 600 4	125
C146 10N010 507 2	133	C146 10N016 501 2	139	C146 10N024 506 1	149	C146 10N032 601 4	125
C146 10N010 508 1	135	C146 10N016 502 1	141	C146 10N024 506 2	149	C146 10N032 650 4	125
C146 10N010 508 2	135	C146 10N016 502 2	141	C146 10N024 507 2	149	C146 10R003 500 4	111
C146 10N010 509 1	135	C146 10N016 503 2	141	C146 10N024 508 1	151	C146 10R003 600 4	111
C146 10N010 509 2	135	C146 10N016 504 1	143	C146 10N024 508 2	151	C146 10R003 804 4	111
C146 10N010 600 1	131	C146 10N016 504 2	143	C146 10N024 509 2	151	C146 10R006 506 1	127
C146 10N010 600 2	131	C146 10N016 505 2	143	C146 10N024 600 1	147	C146 10R006 506 8	127
C146 10N010 601 1	131	C146 10N016 506 1	141	C146 10N024 600 2	147	C146 10R006 507 1	127
C146 10N010 601 2	131	C146 10N016 506 2	141	C146 10N024 600 3	155	C146 10R006 556 8	127
C146 10N010 602 1	133	C146 10N016 507 2	141	C146 10N024 601 2	147	C146 10R006 606 1	127
C146 10N010 602 2	133	C146 10N016 508 1	143	C146 10N024 602 1	149	C146 10R006 606 8	127
C146 10N010 603 1	133	C146 10N016 508 2	143	C146 10N024 602 2	149	C146 10R006 607 1	127
C146 10N010 603 2	133	C146 10N016 509 2	143	C146 10N024 603 2	149	C146 10R006 656 1	127
C146 10N010 604 1	135	C146 10N016 600 1	139	C146 10N024 604 1	151	C146 10R006 656 8	127

Bestell Nr. / Part No.	Seite / Page	Bestell Nr. / Part No.	Seite / Page	Bestell Nr. / Part No.	Seite / Page	Bestell Nr. / Part No.	Seite / Page
C146 10R006 804 1	127	C146 10R016 500 8	139	C146 10R024 552 1	151	C146 11F010 000 8	162, 163
C146 10R006 804 8	127	C146 10R016 501 8	139	C146 10R024 552 8	151	C146 11F010 901 8	162, 163
C146 10R006 805 1	127	C146 10R016 502 1	143	C146 10R024 556 1	149	C146 11F010 902 8	162, 163
C146 10R006 854 8	127	C146 10R016 502 8	143	C146 10R024 556 8	149	C146 11F016 000 8	164, 165
C146 10R010 500 1	131	C146 10R016 503 8	143	C146 10R024 600 1	147	C146 11F016 901 8	164, 165
C146 10R010 500 4	115	C146 10R016 506 1	141	C146 10R024 600 3	155	C146 11F016 902 8	164, 165
C146 10R010 500 8	131	C146 10R016 506 8	141	C146 10R024 600 8	147	C146 11F024 000 8	166, 167
C146 10R010 502 1	135	C146 10R016 507 8	141	C146 10R024 601 8	147	C146 11F024 901 8	166, 167
C146 10R010 502 8	135	C146 10R016 550 1	139	C146 10R024 602 1	151	C146 11F024 902 8	166, 167
C146 10R010 506 1	133	C146 10R016 550 4	119	C146 10R024 602 8	151	C146 11G006 506 1	160
C146 10R010 506 8	133	C146 10R016 550 8	139	C146 10R024 603 8	151	C146 11G006 506 8	160
C146 10R010 550 1	131	C146 10R016 552 1	143	C146 10R024 606 1	149	C146 11G006 507 1	160
C146 10R010 550 4	115	C146 10R016 552 8	143	C146 10R024 606 8	149	C146 11G006 507 8	160
C146 10R010 550 8	131	C146 10R016 556 1	141	C146 10R024 607 8	149	C146 11G006 556 1	160
C146 10R010 552 1	135	C146 10R016 556 8	141	C146 10R024 650 1	147	C146 11G006 606 1	160
C146 10R010 552 8	135	C146 10R016 600 1	139	C146 10R024 650 3	155	C146 11G006 606 8	160
C146 10R010 556 1	133	C146 10R016 600 4	119	C146 10R024 650 8	147	C146 11G006 607 1	160
C146 10R010 556 8	133	C146 10R016 600 8	139	C146 10R024 652 1	151	C146 11G006 607 8	160
C146 10R010 600 1	131	C146 10R016 601 8	139	C146 10R024 652 8	151	C146 11G010 500 1	162
C146 10R010 600 4	115	C146 10R016 602 1	143	C146 10R024 656 1	149	C146 11G010 500 8	162
C146 10R010 600 8	131	C146 10R016 602 8	143	C146 10R024 656 8	149	C146 11G010 501 1	162
C146 10R010 601 8	131	C146 10R016 603 8	143	C146 10R024 802 1	147	C146 11G010 501 8	162
C146 10R010 602 1	135	C146 10R016 606 1	141	C146 10R024 802 3	155	C146 11G010 600 1	162
C146 10R010 602 8	135	C146 10R016 606 8	141	C146 10R024 802 8	147	C146 11G010 600 8	162
C146 10R010 603 8	135	C146 10R016 607 8	141	C146 10R024 803 8	147	C146 11G010 601 1	162
C146 10R010 606 1	133	C146 10R016 650 1	139	C146 10R024 804 1	149	C146 11G010 601 8	162
C146 10R010 606 8	133	C146 10R016 650 4	119	C146 10R024 804 8	149	C146 11G016 500 1	164
C146 10R010 607 1	133	C146 10R016 650 8	139	C146 10R024 805 8	149	C146 11G016 500 8	164
C146 10R010 607 8	133	C146 10R016 652 1	143	C146 10R024 852 1	147	C146 11G016 501 1	164
C146 10R010 650 1	131	C146 10R016 652 8	143	C146 10R024 852 3	155	C146 11G016 501 8	164
C146 10R010 650 4	115	C146 10R016 656 1	141	C146 10R024 852 8	147	C146 11G016 600 1	164
C146 10R010 650 8	131	C146 10R016 656 8	141	C146 10R024 854 1	149	C146 11G016 600 8	164
C146 10R010 652 1	135	C146 10R016 802 1	139	C146 10R024 854 8	149	C146 11G016 601 1	164
C146 10R010 652 8	135	C146 10R016 802 8	139	C146 10R024 903 8	153	C146 11G016 601 8	164
C146 10R010 656 1	133	C146 10R016 803 8	139	C146 10R024 908 8	153	C146 11G024 500 1	166
C146 10R010 656 8	133	C146 10R016 804 1	141	C146 10R024 909 8	153	C146 11G024 500 8	166
C146 10R010 802 1	131	C146 10R016 804 4	119	C146 10R025 500 2	119	C146 11G024 501 1	166
C146 10R010 802 8	131	C146 10R016 804 8	141	C146 10R025 550 2	119	C146 11G024 501 8	166
C146 10R010 803 1	131	C146 10R016 805 8	141	C146 10R025 600 2	119	C146 11G024 600 1	166
C146 10R010 803 8	131	C146 10R016 852 1	139	C146 10R025 650 2	119	C146 11G024 600 8	166
C146 10R010 804 1	133	C146 10R016 852 8	139	C146 10R025 804 2	119	C146 11G024 601 1	166
C146 10R010 804 4	115	C146 10R016 854 1	141	C146 10R025 854 2	119	C146 11G024 601 8	166
C146 10R010 804 8	133	C146 10R016 854 4	119	C146 10Z000 002 8	80	C146 11R006 506 1	161
C146 10R010 805 1	133	C146 10R016 854 8	141	C146 10Z001 001 8	80	C146 11R006 506 8	161
C146 10R010 805 8	133	C146 10R016 902 8	145	C146 10Z002 001 8	80	C146 11R006 507 1	161
C146 10R010 852 1	131	C146 10R016 910 8	145	C146 10Z003 100 4	110, 111	C146 11R006 556 1	161
C146 10R010 852 8	131	C146 10R024 500 1	147	C146 10Z006 100 1	128, 129	C146 11R006 556 8	161
C146 10R010 854 1	133	C146 10R024 500 3	155	C146 10Z006 200 1	128, 129	C146 11R006 606 1	161
C146 10R010 854 4	115	C146 10R024 500 8	147	C146 10Z010 100 1	136, 137	C146 11R006 606 8	161
C146 10R010 854 8	133	C146 10R024 501 8	147	C146 10Z010 200 1	136, 137	C146 11R006 607 1	161
C146 10R010 902 8	137	C146 10R024 502 1	151	C146 10Z015 100 2	116, 117	C146 11R006 656 8	161
C146 10R015 500 2	115	C146 10R024 502 8	151	C146 10Z016 100 1	144, 145	C146 11R010 500 1	163
C146 10R015 550 2	115	C146 10R024 503 8	151	C146 10Z016 200 1	144, 145	C146 11R010 500 8	163
C146 10R015 600 2	115	C146 10R024 506 1	149	C146 10Z024 100 1	152, 153	C146 11R010 550 1	163
C146 10R015 650 2	115	C146 10R024 506 8	149	C146 10Z024 200 1	152, 153	C146 11R010 550 8	163
C146 10R015 804 2	115	C146 10R024 507 8	149	C146 10Z025 100 2	120, 121	C146 11R010 600 1	163
C146 10R015 854 2	115	C146 10R024 550 1	147	C146 11F006 001 8	160, 161	C146 11R010 600 8	163
C146 10R016 500 1	139	C146 10R024 550 3	155	C146 11F006 901 8	160, 161	C146 11R010 601 1	163
C146 10R016 500 4	119	C146 10R024 550 8	147	C146 11F006 902 8	160, 161	C146 11R010 601 8	163



Bestell Nr. / Part No.	Seite / Page	Bestell Nr. / Part No.	Seite / Page	Bestell Nr. / Part No.	Seite / Page	Bestell Nr. / Part No.	Seite / Page
C146 11R010 650 1	163	C146 21R010 506 8	133	C146 21R016 550 8	139, 145	C146 21R024 650 1	147, 153
C146 11R010 650 8	163	C146 21R010 550 1	131, 137	C146 21R016 552 1	143	C146 21R024 650 8	147, 153
C146 11R016 500 1	165	C146 21R010 550 4	115	C146 21R016 552 8	143	C146 21R024 652 1	151
C146 11R016 500 8	165	C146 21R010 550 8	131, 137	C146 21R016 556 1	141	C146 21R024 652 8	151
C146 11R016 501 8	165	C146 21R010 552 1	135	C146 21R016 556 8	141	C146 21R024 656 1	149
C146 11R016 550 1	165	C146 21R010 552 8	135	C146 21R016 600 1	139, 145	C146 21R024 656 8	149
C146 11R016 550 8	165	C146 21R010 556 1	133	C146 21R016 600 4	119	C146 21R024 802 1	147
C146 11R016 600 1	165	C146 21R010 556 8	133	C146 21R016 600 8	139, 145	C146 21R024 802 8	147
C146 11R016 600 8	165	C146 21R010 600 1	131, 137	C146 21R016 601 8	139, 145	C146 21R024 803 8	147
C146 11R016 601 8	165	C146 21R010 600 4	115	C146 21R016 602 1	143	C146 21R024 804 1	149
C146 11R016 650 1	165	C146 21R010 600 8	131, 137	C146 21R016 602 8	143	C146 21R024 804 8	149
C146 11R016 650 8	165	C146 21R010 601 8	131, 137	C146 21R016 603 8	143	C146 21R024 805 8	149
C146 11R024 500 1	167	C146 21R010 602 1	135	C146 21R016 606 1	141	C146 21R024 852 1	147
C146 11R024 500 8	167	C146 21R010 602 8	135	C146 21R016 606 8	141	C146 21R024 852 8	147
C146 11R024 501 8	167	C146 21R010 603 8	135	C146 21R016 607 8	141	C146 21R024 854 1	149
C146 11R024 550 1	167	C146 21R010 606 1	133	C146 21R016 650 1	139, 145	C146 21R024 854 8	149
C146 11R024 550 8	167	C146 21R010 606 8	133	C146 21R016 650 4	119	C146 21R024 913 8	77
C146 11R024 600 1	167	C146 21R010 607 1	133	C146 21R016 650 8	139, 145	C146 21R025 500 2	119
C146 11R024 600 8	167	C146 21R010 607 8	133	C146 21R016 652 1	143	C146 21R025 550 2	119
C146 11R024 601 8	167	C146 21R010 650 1	131, 137	C146 21R016 652 8	143	C146 21R025 600 2	119
C146 11R024 650 1	167	C146 21R010 650 4	115	C146 21R016 656 1	141	C146 21R025 650 2	119
C146 11R024 650 8	167	C146 21R010 650 8	131, 137	C146 21R016 656 8	141	C146 21R025 804 2	119
C146 16F003 000 4	111	C146 21R010 652 1	135	C146 21R016 802 1	139	C146 21R025 854 2	119
C146 16N003 500 4	111	C146 21R010 652 8	135	C146 21R016 802 8	139	C146 21R032 500 4	123
C146 16R003 500 4	111	C146 21R010 656 1	133	C146 21R016 803 8	139	C146 21R032 501 4	123
C146 16R003 600 4	111	C146 21R010 656 8	133	C146 21R016 804 1	141	C146 21R032 502 4	123
C146 21G006 501 1	128	C146 21R010 802 1	131	C146 21R016 804 4	119	C146 21R032 503 4	123
C146 21G006 506 8	128	C146 21R010 802 8	131	C146 21R016 804 8	141	C146 21R032 550 4	123
C146 21G010 500 1	136	C146 21R010 803 1	131	C146 21R016 805 8	141	C146 21R032 552 4	123
C146 21G010 500 8	136	C146 21R010 803 8	131	C146 21R016 852 1	139	C146 21R032 600 4	123
C146 21G010 600 1	136	C146 21R010 804 1	133	C146 21R016 852 8	139	C146 21R032 601 4	123
C146 21G010 600 8	136	C146 21R010 804 4	115	C146 21R016 854 1	141	C146 21R032 602 4	123
C146 21G016 500 1	144	C146 21R010 804 8	133	C146 21R016 854 4	119	C146 21R032 603 4	123
C146 21G016 501 8	144	C146 21R010 805 1	133	C146 21R016 854 8	141	C146 21R032 650 4	123
C146 21G016 600 1	144	C146 21R010 805 8	133	C146 21R016 910 8	77	C146 21R032 652 4	123
C146 21G016 601 8	144	C146 21R010 852 1	131	C146 21R024 500 1	147, 153	C146 21R032 802 4	123
C146 21G024 500 1	152	C146 21R010 852 8	131	C146 21R024 500 8	147, 153	C146 21R032 803 4	123
C146 21G024 501 8	152	C146 21R010 854 1	133	C146 21R024 501 8	147, 153	C146 21R032 852 4	123
C146 21G024 600 1	152	C146 21R010 854 4	115	C146 21R024 502 1	151	C146 30F003 000 4	112, 113
C146 21G024 601 8	152	C146 21R010 854 8	133	C146 21R024 502 8	151	C146 30F003 004 4	112, 113
C146 21R006 506 1	127	C146 21R010 902 8	77	C146 21R024 503 8	151	C146 30F003 500 4	112
C146 21R006 506 8	127	C146 21R015 500 2	115	C146 21R024 506 1	149	C146 30G003 500 4	112
C146 21R006 507 1	127	C146 21R015 550 2	115	C146 21R024 506 8	149	C146 30G003 600 4	112
C146 21R006 556 8	127	C146 21R015 600 2	115	C146 21R024 507 8	149	C146 30G003 804 4	112
C146 21R006 606 1	127	C146 21R015 650 2	115	C146 21R024 550 1	147	C146 30N003 500 4	113
C146 21R006 606 8	127	C146 21R015 804 2	115	C146 21R024 550 8	147, 153	C146 30R003 500 4	113
C146 21R006 607 1	127	C146 21R015 854 2	115	C146 21R024 552 1	151	C146 30R003 600 4	113
C146 21R006 656 1	127	C146 21R016 500 1	139, 145	C146 21R024 552 8	151	C146 30R003 804 4	113
C146 21R006 656 8	127	C146 21R016 500 4	119	C146 21R024 556 1	149	C146 30Z003 100 4	112, 113
C146 21R006 804 1	127	C146 21R016 500 8	139, 145	C146 21R024 556 8	149	C146 31N003 500 4	113
C146 21R006 804 8	127	C146 21R016 501 8	139, 145	C146 21R024 600 1	147, 153	C146 A00 001 E8	80
C146 21R006 805 1	127	C146 21R016 502 1	143	C146 21R024 600 8	147, 153	C146 A03 001 E8	58, 69
C146 21R006 854 8	127	C146 21R016 502 8	143	C146 21R024 601 8	147, 153	C146 A03 501 E8	58, 73
C146 21R010 500 1	131, 137	C146 21R016 503 8	143	C146 21R024 602 1	151	C146 A03 801 E8	58, 75
C146 21R010 500 4	115	C146 21R016 506 1	141	C146 21R024 602 8	151	C146 A05 001 E8	58, 67
C146 21R010 500 8	131, 137	C146 21R016 506 8	141	C146 21R024 603 8	151	C146 A10 001 E8	58
C146 21R010 502 1	135	C146 21R016 507 8	141	C146 21R024 606 1	149	C146 A20 001 G8	58, 61
C146 21R010 502 8	135	C146 21R016 550 1	139, 145	C146 21R024 606 8	149	C146 B00 001 E8	80
C146 21R010 506 1	133	C146 21R016 550 4	119	C146 21R024 607 8	149	C146 B03 001 E8	58, 69

Bestell Nr. / Part No.	Seite / Page	Bestell Nr. / Part No.	Seite / Page	Bestell Nr. / Part No.	Seite / Page	Bestell Nr. / Part No.	Seite / Page
C146 B03 501 E8	58, 73	FG 0300 146 (7)	47	N16 013 0010	171	TN01 025 0008 (1)	105
C146 B03 801 E8	58, 75	FG 1000 146	61, 63, 65, 67, 69, 71, 73, 75, 80	N16 016 0010	171	TN01 025 0010 (1)	35, 37, 39, 41, 43, 71
C146 B05 001 E8	58, 67	FN01 010 0130 (2)	61	N16 021 0010	171	TN01 025 0043 (1)	71
C146 B10 001 E8	58	FN01 010 0131 (2)	61	T 1860 000	106	TN02 010 0130 (2)	61
C146 B20 001 G8	58, 61	FN02 010 0130 (2)	61	T 1860 010	106	TN02 010 0131 (2)	61
C146 C04 001 E8	58, 71	FN02 010 0131 (2)	61	T 1861 002	106	TN02 016 0002 (1)	11, 13, 15, 17, 19, 21, 23, 63
C146 C05 001 E8	58, 71	HN01 016 0002 (1)	11, 13, 15, 17, 19, 21, 23, 63	T 1861 012	106	TN02 016 0002 (2)	11, 13, 15, 17, 19, 21, 23, 63
C146 C10 001 G8	58, 63	HN01 016 0002 (2)	11, 13, 15, 17, 19, 21, 23, 63	T 1862 001	106	TA 0000	24, 44, 63, 65, 67, 69, 71, 73, 75
C146 D04 001 E8	58, 71	HN01 016 0003 (1)	11, 13, 15, 17, 19, 21, 23, 63	TA 0000 121	71	TN02 016 0003 (1)	11, 13, 15, 17, 19, 21, 23, 63
C146 D05 001 E8	58, 71	HN01 016 0003 (2)	11, 13, 15, 17, 19, 21, 23, 63	TA 0000 124	67, 69, 75	TN02 016 0003 (2)	11, 13, 15, 17, 19, 21, 23, 63
C146 D10 001 E8	58, 63	HN01 016 0003 (2)	11, 13, 15, 17, 19, 21, 23, 63	TA 0000 141	24, 44, 63, 71	TN02 016 0005 (1)	11, 13, 15, 17, 19, 21, 23, 63
C146 E12 001 E8	59, 77	HN01 016 0005 (1)	11, 13, 15, 17, 19, 21, 23, 63	TA 0000 144	67, 69, 75	TA 0000 163	24, 44, 63, 71
C146 F12 001 G8	59, 77	HN01 016 0005 (2)	11, 13, 15, 17, 19, 21, 23, 63	TA 0000 180	69, 75	TA 0000 184	65
C146 G01 014 G8	59, 79	HN01 016 0015 (1)	11, 13, 15, 17, 19, 21, 23, 63	TA 0000 202	24, 63	TA 0000 202	24, 63
C146 G01 024 G8	59, 79	HN01 016 0015 (2)	11, 13, 15, 17, 19, 21, 23, 63	TA 0000 401	73	TA 0000 401	73
C146 G02 014 G8	59, 79	HN01 016 0016 (1)	11, 13, 15, 17, 19, 21, 23, 63	TA 0000 402	73	TA 0001 146 000 1	24, 63
C146 G02 024 G8	59, 79	HN01 025 0001 (1)	35, 37, 39, 41, 43, 71	TA 0001 146 000 1	24, 63	TA 0002 146 000 1	24, 63
C146 H01 034 G8	59, 79	HN01 025 0007 (1)	105	TA 0003 146 000 1	71	TA 0003 146 000 1	71
C146 H01 044 G8	59, 79	HN01 025 0008 (1)	105	TA 0004 146 000 1	44, 71	TA 0004 146 000 3	44, 71
C146 H02 034 G8	59, 79	HN01 025 0010 (1)	35, 37, 39, 41, 43, 71	TA 0005 146 000 3	44, 71	TA 0007 146 000 3	24, 63
C146 H02 044 G8	59, 79	HN02 016 0002 (1)	11, 13, 15, 17, 19, 21, 23, 63	TA 0010 146 000 1	65	TA 0010 146 000 1	65
C146 N32 009 G1	176	HN02 016 0002 (2)	11, 13, 15, 17, 19, 21, 23, 63	TA 0010 146 000 2	67, 75	TA 0010 146 000 2	67, 75
C146 N32 015 G1	176	HN02 016 0002 (2)	11, 13, 15, 17, 19, 21, 23, 63	TA 0010 146 000 3	67	TA 0010 146 000 3	67
C146 N32 015 G2	176	HN02 016 0003 (1)	11, 13, 15, 17, 19, 21, 23, 63	TA 0010 146 000 4	69, 75	TA 0010 146 000 4	69, 75
C146 N32 025 G1	176	HN02 016 0003 (2)	11, 13, 15, 17, 19, 21, 23, 63	TA 0100 146	24, 63	TA 0100 146	24, 63
C146 N32 025 G2	176	HN02 016 0005 (1)	11, 13, 15, 17, 19, 21, 23, 63	TA 0200 146	61	TA 0200 146	61
C146 N32 037 G1	176	HN02 016 0005 (2)	11, 13, 15, 17, 19, 21, 23, 63	TA 0500	24	TB 0200 146	69, 75
C146 N32 050 G1	176	HN02 016 0005 (2)	11, 13, 15, 17, 19, 21, 23, 63	TB 0200 146	69, 75	TB 0500 146	65
C146 N33 009 G1	176	HN02 016 0015 (1)	11, 13, 15, 17, 19, 21, 23, 63	TB 0600 146	44	TN01 010 0130 (2)	61
C146 N33 015 G1	176	HN02 025 0001 (1)	35, 37, 39, 41, 43, 71, 105	TN01 010 0131 (2)	61	TN01 010 0131 (2)	61
C146 N33 015 G2	176	HN02 025 0010 (1)	35, 37, 39, 41, 43, 71, 105	TN01 016 0002 (1)	11, 13, 15, 17, 19, 21, 23, 63	TN01 016 0002 (1)	11, 13, 15, 17, 19, 21, 23, 63
C146 N33 025 G1	176	N01 016 0040 8	179	TN01 016 0002 (2)	11, 13, 15, 17, 19, 21, 23, 63	TN01 016 0002 (2)	11, 13, 15, 17, 19, 21, 23, 63
C146 N33 037 G1	176	N02 016 0040 8	179	TN01 016 0015 (1)	11, 13, 15, 17, 19, 21, 23, 63	TN01 016 0003 (1)	11, 13, 15, 17, 19, 21, 23, 63
C146 N33 050 G1	176	N06 080 0003 1	176	TN01 016 0003 (2)	11, 13, 15, 17, 19, 21, 23, 63	TN01 016 0003 (2)	11, 13, 15, 19, 21, 23, 63
C146 P06 001 G8	59	N06 080 0003 2	176	TN01 016 0005 (1)	11, 13, 15, 17, 19, 21, 23, 63	TN01 016 0005 (1)	11, 13, 15, 17, 19, 21, 23, 63
C146 P06 002 G8	59	N06 080 0003 3	176	TN01 016 0005 (2)	11, 13, 15, 17, 19, 21, 23, 63	TN01 016 0005 (2)	11, 13, 15, 19, 21, 23, 63
C146 P10 001 G8	59	N06 080 0003 4	176	TN01 016 0005 (2)	11, 13, 15, 17, 19, 21, 23, 63	TN01 016 0005 (2)	11, 13, 15, 19, 21, 23, 63
C146 P10 002 G8	59	N07 045 0001 L	176	TN01 016 0005 (2)	11, 13, 15, 17, 19, 21, 23, 63	TN01 016 0005 (2)	11, 13, 15, 19, 21, 23, 63
C146 P16 001 G8	59	N15 006 000 9Z	69, 75	TN01 016 0015 (1)	11, 13, 15, 17, 19, 21, 23, 63	TN01 016 0015 (1)	11, 13, 15, 17, 19, 21, 23, 63
C146 P16 002 G8	59	N15 010 000 7Z	69, 75	TN01 016 0016 (1)	11, 13, 15, 17, 19, 21, 23, 63	TN01 016 0016 (1)	11, 13, 15, 17, 19, 21, 23, 63
C146 P24 001 G8	59	N16 011 0010	171	TN01 025 0001 (1)	35, 37, 39, 41, 43, 71	TN01 025 0001 (1)	35, 37, 39, 41, 43, 71
C146 P24 002 G8	59			TN01 025 0007 (1)	105	TN01 025 0007 (1)	105
C146 P24 101 G8	59						
C146 P24 102 G8	59						
C146 S06 001 G8	59						
C146 S06 002 G8	59						
C146 S10 001 G8	59						
C146 S10 002 G8	59						
C146 S16 001 G8	59						
C146 S16 002 G8	59						
C146 S24 001 G8	59						
C146 S24 002 G8	59						
C146 S24 101 G8	59						
C146 S24 102 G8	59						
FG 0200 146 1	44, 71, 80						
FG 0300 146 1	24, 63, 65, 80						
FG 0300 146 3	69, 73, 75, 80						
FG 0300 146 4	67, 80						



Bestell Nr. / Part No.	Seite / Page	Bestell Nr. / Part No.	Seite / Page	Bestell Nr. / Part No.	Seite / Page	Bestell Nr. / Part No.	Seite / Page
VN01 016 0027 (2)C	11, 13, 15, 17, 19, 21, 23, 27, 65	VN02 016 0003 (1)	11, 13, 15, 17, 19, 21, 23, 63	VN02 025 0037 (1)C	35, 37, 39, 41, 43, 47, 178	VN16 210 0003 V	171
VN01 016 0028 (1)C	11, 13, 15, 17, 19, 21, 23, 27, 65, 178	VN02 016 0003 (2)	11, 13, 15, 17, 19, 21, 23, 63	VN02 025 0037 (2)C	35, 37, 39, 41, 43, 47	VN16 210 0013 X	170
VN01 016 0028 (2)C	11, 13, 15, 17, 19, 21, 23, 27, 65	VN02 016 0005 (1)	11, 13, 15, 17, 19, 21, 23, 63	VN02 025 0038 (1)C	35, 37, 39, 41, 43, 47, 178	VN16 210 0014 X	170
VN01 016 0040 (8) X	65	VN02 016 0005 (2)	11, 13, 15, 17, 19, 21, 23, 63	VN02 025 0038 (2)C	35, 37, 39, 41, 43, 47	VN16 210 0026 X	173
VN01 025 0001 (101)	35, 37, 71	VN02 016 0015 (1)	11, 13, 15, 17, 19, 21, 23, 63	VN02 025 0039 (1)C	35, 37, 39, 41, 43, 47, 178	VN16 210 0027 X	172
VN01 025 0001 (102)	35, 37, 39, 41, 43, 71	VN02 016 0016 (1)	11, 13, 15, 17, 19, 21, 23, 63	VN02 025 0039 (2)C	35, 37, 39, 41, 43, 47	VN16 210 0028 X	171
VN01 025 0007 (101)	105	VN02 016 0024 (1)C	11, 13, 15, 17, 19, 21, 23, 27, 65, 178	VN02 025 0043 (1)	71	VN16 210 0029 X	171
VN01 025 0008 (101)	105	VN02 016 0024 (2)C	11, 13, 15, 17, 19, 21, 23, 27, 65	VN02 036 0001 (1)C	69, 75, 178	VN16 250 0102 V	171
VN01 025 0010 (101)	35, 37, 71	VN02 016 0025 (1)C	11, 13, 15, 17, 19, 21, 23, 27, 65, 178	VN02 036 0002 (1)C	69, 75, 178	VN16 250 0103 V	171
VN01 025 0010 (101)	39, 41, 43	VN02 016 0025 (2)C	11, 13, 15, 17, 19, 21, 23, 27, 65	VN02 036 0003 (1)C	69, 75, 178	VN16 250 0114 X	170
VN01 025 0010 (102)	35, 37, 39, 41, 43, 71	VN02 016 0026 (1)C	11, 13, 15, 17, 19, 21, 23, 27, 65, 178	VN02 036 0004 (1)C	69, 75, 178	VN16 250 0126 X	173
VN01 025 0029 (1)C	67, 178	VN02 016 0026 (2)C	11, 13, 15, 17, 19, 21, 23, 27, 65	VN02 036 0005 (1)C	69, 75, 178	VN16 250 0127 X	172
VN01 025 0029 (2)C	67	VN02 016 0027 (1)C	11, 13, 15, 17, 19, 21, 23, 27, 65	VN03 030 0020	174	VN16 250 0131 V	77
VN01 025 0030 (1)C	67, 178	VN02 016 0027 (2)C	11, 13, 15, 17, 19, 21, 23, 27, 65	VN03 030 0021	174	VN16 290 0002 V	171
VN01 025 0030 (2)C	67	VN02 016 0028 (1)C	11, 13, 15, 17, 19, 21, 23, 27, 65, 178	VN03 030 3000 X	174	VN16 290 0003 V	171
VN01 025 0031 (1)C	67, 178	VN02 016 0028 (2)C	11, 13, 15, 17, 19, 21, 23, 27, 65	VN13 040 0008 (1) X	174	VN16 290 0003 X	170
VN01 025 0031 (2)C	67	VN02 016 0029 (1)C	11, 13, 15, 17, 19, 21, 23, 27, 65, 178	VN13 040 0009 (1) X	174	VN16 290 0013 X	170
VN01 025 0032 (1)C	67, 178	VN02 016 0029 (2)C	11, 13, 15, 17, 19, 21, 23, 27, 65, 178	VN16 020 0113 (1) X	172	VN16 290 0014 X	170
VN01 025 0032 (2)C	67	VN02 016 0030 (1)C	11, 13, 15, 17, 19, 21, 23, 27, 65, 178	VN16 025 0113 (1) X	172	VN16 290 0026 X	173
VN01 025 0033 (1)C	67, 178	VN02 016 0030 (2)C	11, 13, 15, 17, 19, 21, 23, 27, 65	VN16 032 0113 (1) X	172	VN16 290 0027 X	172
VN01 025 0033 (2)C	67	VN02 016 0031 (1)C	11, 13, 15, 17, 19, 21, 23, 27, 65	VN16 040 0113 (1) X	172	VN16 290 0028 X	171
VN01 025 0035 (1)C	35, 37, 39, 41, 43, 47, 178	VN02 016 0031 (2)C	11, 13, 15, 17, 19, 21, 23, 27, 65	VN16 110 0004 V	171	VN16 290 0029 X	171
VN01 025 0035 (2)C	35, 37, 39, 41, 43, 47	VN02 016 0032 (1)C	11, 13, 15, 17, 19, 21, 23, 27, 65, 178	VN16 110 0013 X	170	VN16 320 0102 V	171
VN01 025 0036 (1)C	35, 37, 39, 41, 43, 47, 178	VN02 016 0032 (2)C	11, 13, 15, 17, 19, 21, 23, 27, 65	VN16 110 0014 X	170	VN16 320 0103 V	171
VN01 025 0036 (2)C	35, 37, 39, 41, 43, 47	VN02 016 0040 (8) X	65	VN16 110 0026 X	173	VN16 320 0114 X	170
VN01 025 0037 (1)C	35, 37, 39, 41, 43, 47, 178	VN02 025 0001 (101)	35, 37, 39, 41, 43, 71, 105	VN16 110 0027 X	172	VN16 320 0126 X	173
VN01 025 0037 (2)C	35, 37, 39, 41, 43, 47	VN02 025 0001 (102)	35, 37, 71	VN16 110 0028 X	171	VN16 320 0127 X	172
VN01 025 0038 (1)C	35, 37, 39, 41, 43, 47, 178	VN02 025 0001 (102)	39, 41, 43	VN16 110 0029 X	171	VN16 360 0013 X	170
VN01 025 0038 (2)C	35, 37, 39, 41, 43, 47	VN02 025 0010 (101)	35, 37, 39, 41, 43, 71, 105	VN16 135 0002 V	171	VN16 360 0014 X	170
VN01 025 0039 (1)C	35, 37, 39, 41, 43, 47, 178	VN02 025 0010 (102)	35, 37, 71	VN16 135 0003 V	171	VN16 400 0114 X	170
VN01 025 0039 (2)C	35, 37, 39, 41, 43, 47	VN02 025 0010 (102)	39, 41, 43	VN16 135 0013 X	170	VN16 400 0126 X	173
VN01 025 0043 (1)	71	VN02 025 0029 (1)C	67, 178	VN16 135 0014 X	170	VN16 400 0127 X	172
VN01 036 0001 (1)C	69, 75, 178	VN02 025 0029 (2)C	67	VN16 135 0026 X	173	VN16 420 0013 X	170
VN01 036 0002 (1)C	69, 75, 178	VN02 025 0030 (1)C	67, 178	VN16 135 0027 X	172	VN16 420 0014 X	170
VN01 036 0003 (1)C	69, 75, 178	VN02 025 0030 (2)C	67	VN16 135 0028 X	171	VN16 500 0114 X	170
VN01 036 0004 (1)C	69, 75, 178	VN02 025 0031 (1)C	67, 178	VN16 135 0029 X	171	VN17 050 0004 (1)	174
VN01 036 0005 (1)C	69, 75, 178	VN02 025 0031 (2)C	67	VN16 160 0002 V	171	VN17 050 0004 (101)	174
VN02 010 0130 (2)	61	VN02 025 0032 (1)C	67, 178	VN16 160 0003 V	171	ZN01 010 0130 (2)	61
VN02 010 0131 (2)	61	VN02 025 0032 (2)C	67	VN16 160 0013 X	170	ZN01 010 0131 (2)	61
VN02 016 0002 (1)	11, 13, 15, 17, 19, 21, 23, 63	VN02 025 0033 (1)C	67, 178	VN16 160 0014 X	170	ZN01 016 0002 (1)	11, 13, 15, 17, 19, 21, 23, 63
VN02 016 0002 (2)	11, 13, 15, 17, 19, 21, 23, 63	VN02 025 0033 (2)C	67	VN16 160 0026 X	173	ZN01 016 0002 (2)	11, 13, 15, 17, 19, 21, 23, 63
		VN02 025 0035 (1)C	35, 37, 39, 41, 43, 47, 178	VN16 160 0027 X	172	ZN01 016 0003 (1)	11, 13, 15, 17, 19, 21, 23, 63
		VN02 025 0035 (2)C	35, 37, 39, 41, 43, 47	VN16 160 0028 X	171	ZN01 016 0003 (2)	11, 13, 15, 17, 19, 21, 23, 63
		VN02 025 0036 (1)C	35, 37, 39, 41, 43, 47, 178	VN16 160 0029 X	171	ZN01 016 0005 (1)	11, 13, 15, 17, 19, 21, 23, 63
		VN02 025 0036 (2)C	35, 37, 39, 41, 43, 47	VN16 160 0102 V	171	ZN01 016 0005 (2)	11, 13, 15, 17, 19, 21, 23, 63
				VN16 160 0102 V	171	ZN01 016 0015 (1)	11, 13, 15, 17, 19, 21, 23, 63
				VN16 160 0126 X	173	ZN01 016 0015 (2)	11, 13, 15, 17, 19, 21, 23, 63
				VN16 160 0127 X	172	ZN01 016 0016 (1)	11, 13, 15, 17, 19, 21, 23, 63
				VN16 200 0102 V	171	ZN01 016 0016 (2)	11, 13, 15, 17, 19, 21, 23, 63
				VN16 200 0103 V	171	ZN01 025 0001 (1)	35, 37, 39, 41, 43, 71
				VN16 200 0114 X	170	ZN01 025 0001 (2)	35, 37, 39, 41, 43, 71
				VN16 200 0126 X	173		
				VN16 200 0127 X	172		
				VN16 210 0002 V	171		
						ZN01 025 0007 (1)	105

Bestell Nr. / Part No.	Seite / Page	Bestell Nr. / Part No.	Seite / Page	Bestell Nr. / Part No.	Seite / Page	Bestell Nr. / Part No.	Seite / Page
ZN01 025 0008 (1)	105						
ZN01 025 0010 (1)	35, 37, 39, 41, 43, 71						
ZN01 025 0010 (2)	35, 37, 39, 41, 43, 71						
ZN02 010 0130 (2)	61						
ZN02 010 0131 (2)	61						
ZN02 016 0002 (1)	11, 13, 15, 17, 19, 21, 23, 63						
ZN02 016 0002 (2)	11, 13, 15, 17, 19, 21, 23, 63						
ZN02 016 0003 (1)	11, 13, 15, 17, 19, 21, 23, 63						
ZN02 016 0003 (2)	11, 13, 15, 17, 19, 21, 23, 63						
ZN02 016 0005 (1)	11, 13, 15, 17, 19, 21, 23, 63						
ZN02 016 0005 (2)	11, 13, 15, 17, 19, 21, 23, 63						
ZN02 016 0015 (1)	11, 13, 15, 17, 19, 21, 23, 63						
ZN02 016 0016 (1)	11, 13, 15, 17, 19, 21, 23, 63						
ZN02 025 0001 (1)	35, 37, 39, 41, 43, 71, 105						
ZN02 025 0001 (2)	35, 37, 39, 41, 43, 71						
ZN02 025 0010 (1)	35, 37, 39, 41, 43, 71, 105						
ZN02 025 0010 (2)	35, 37, 39, 41, 43, 71						





## International

### Argentina

Amphenol Argentina  
Av. Callao 930  
2nd Floor Office B "Plaza"  
C1023 AAP Buenos Aires  
Phone +54 11 4815 6886  
www.amphenol.com.ar

### Australia

Amphenol Australia Pty. Ltd.  
2 Fiveways Blvd  
Keysborough  
Victoria 31 73  
Phone +61 3 8796 8888  
www.amphenol.com.au

### Brazil

Amphenol do Brasil Ltda.  
Rua Diogo Moreira 132, 20th Floor  
CEP 05423-101 Sao Paulo SP  
Phone +55 11 3815 1003  
www.amphenol.com.br

### China

Amphenol-Tuchel Electronics  
China Branch  
20 Tianshan Road  
Changzhou 213022  
Phone +86 0519 5110301  
www.amphenol.info

### France

Amphenol Socapex S.A.S.  
948, Promenade de l'Arve, BP 29  
Thyez Cedex, 74311  
Phone +33 4 5089 2800  
www.amphenol-socapex.com

### Germany

Amphenol-Tuchel Electronics GmbH  
August-Haessler-Str. 10  
74080 Heilbronn  
Phone +49 7131 929-0  
www.amphenol.de

### India

Amphenol Interconnect India Pvt Ltd  
105, Bhosari Industrial Area  
Pune - 411 026  
Phone +91 20 27120481  
www.amphenol-in.com

### Italy

Amphenol-Tuchel Italy  
Via Barbaiana n. 5  
20020 Lainate (MI)  
Phone +39 02 932 541  
www.amphenol.info

### Korea

Amphenol DaeShin Elect and  
Precision Co.,Ltd  
558 Songnae-Dong, Sosa-Gu  
Bucheon-City, Kyunggi-Do  
Korea 422-130  
Phone +82 32 610 3800  
www.amphenol.co.kr

### Mexico

Amphenol Mexico  
Prolongacion Reforma 61 - 6 B2  
Col. Paseo de las Lomas  
C.P. 01330 Mexico D.F.  
Phone +52 55 5258 9984  
www.amphenolmexico.com

### Singapore

Asia Pacific Sales Operations  
72 Bendemeer Rd, No.03-32/33  
Hiap Huat House, Luzerne, 339941  
Singapore  
Phone +65 6294 2128  
www.amphenol.com

### South Africa

Amphenol International Ltd  
Chislehurst  
30 Impala Road  
2196 Chislehurst  
Sandton, 2146  
Phone +27 11 7839517  
www.amphenol.co.za

### Spain

Amphenol Espana  
Edificio Burgosol, Oficina 55  
C/Comunidad de Madrid, 35 bis  
Las Rozas (Madrid), 28230  
Phone +34 91 64 07302  
www.amphenol.com

### Taiwan

Amphenol East Asia Limited-Taiwan  
5F, No 361, Fusing 1st Rd  
Gueishan Township,  
Taoyuan County 333  
Phone +886 3 2647 200  
www.amphenol.com

### Turkey

Amphenol Turkey  
Sun Plaza Kat: 15  
Maslak Mah. Bilim Sok.No:15  
34398 Sisli - Istanbul  
Phone: +90 212 367 9220  
www.amphenol.com.tr

### United Kingdom

Amphenol Limited  
Thanet Way,Whitstable  
Kent, CT53JF  
Phone +44 1227 773 200  
www.amphenol.co.uk

### USA

Amphenol-Tuchel Electronics  
6900 Haggerty Road  
Suite 200  
Canton, Michigan 48187  
Phone +1 734 4516400  
www.amphenol.info

Amphenol Corporation  
Corporate Headquarters  
358 Hall Avenue  
Wallingford, CT 06492  
Phone +1 877 267 4366  
Phone +1 203 265 8900  
www.amphenol.com

More Amphenol companies can be found here: [www.amphenol.com](http://www.amphenol.com)



### Important Notice

All technical data have been measured in a laboratory environment and can be different during practical usage of the product. Any product information is for descriptive usage only and not legally binding; particularly the information does not constitute or provide any legal guaranties ("Beschaffensgarantie" or "Haltbarkeitsgarantie").

We reserve the right to change the design due to improvement in quality, development or production requirements.  
This catalogue must not be used in any form or manner without our prior approval in writing (Copyright Law, Fair Trading Law, Civil Code).

Your engineering sales representative:



# Amphenol

Amphenol-Tuchel Electronics GmbH

August-Haessler-Str. 10 · D-74080 Heilbronn · Germany · Phone +49(0)7131 929-0 · Fax +49(0)7131 929-486 · [www.amphenol.info](http://www.amphenol.info)



Компания «ЭлектроПласт» предлагает заключение долгосрочных отношений при поставках импортных электронных компонентов на взаимовыгодных условиях!

Наши преимущества:

- Оперативные поставки широкого спектра электронных компонентов отечественного и импортного производства напрямую от производителей и с крупнейших мировых складов;
- Поставка более 17-ти миллионов наименований электронных компонентов;
- Поставка сложных, дефицитных, либо снятых с производства позиций;
- Оперативные сроки поставки под заказ (от 5 рабочих дней);
- Экспресс доставка в любую точку России;
- Техническая поддержка проекта, помощь в подборе аналогов, поставка прототипов;
- Система менеджмента качества сертифицирована по Международному стандарту ISO 9001;
- Лицензия ФСБ на осуществление работ с использованием сведений, составляющих государственную тайну;
- Поставка специализированных компонентов (Xilinx, Altera, Analog Devices, Intersil, Interpoint, Microsemi, Aeroflex, Peregrine, Syfer, Eurofarad, Texas Instrument, Miteq, Cobham, E2V, MA-COM, Hittite, Mini-Circuits, General Dynamics и др.);

Помимо этого, одним из направлений компании «ЭлектроПласт» является направление «Источники питания». Мы предлагаем Вам помощь Конструкторского отдела:

- Подбор оптимального решения, техническое обоснование при выборе компонента;
- Подбор аналогов;
- Консультации по применению компонента;
- Поставка образцов и прототипов;
- Техническая поддержка проекта;
- Защита от снятия компонента с производства.



#### Как с нами связаться

**Телефон:** 8 (812) 309 58 32 (многоканальный)

**Факс:** 8 (812) 320-02-42

**Электронная почта:** [org@eplast1.ru](mailto:org@eplast1.ru)

**Адрес:** 198099, г. Санкт-Петербург, ул. Калинина, дом 2, корпус 4, литера А.