

Full Color PLCC4 LED

OVSARGB4R8



Features:

- Surface mount device packaged in 8mm tape on 7" diameter reel
- Compatible with automatic placement equipment
- Compatible with infrared and vapor phase reflow solder
- Dimensions: 3.5 x 2.8 x 1.9 mm

Description:

The OVSARGB4R8 provides full color light output from a single package, 3-die design. This surface mount package is an efficient solution in modular applications that require uniform brightness and color-on-demand. Light output is optimized by an interior reflector and the wide viewing angle adds flexibility for applications ranging from hand-held appliances to automotive interiors.

Applications:

- RGB full-color indoor and outdoor displays
- Backlighting
- Coupling into light guides
- Automotive interiors
- Entertainment equipment

Part Number	Chip				Lens Color
	Type	Material	Emitted Color	Intensity Typ. Mcd	
OVSARGB4R8	R	AlInGaP	Red	635	Diffused
	G	InGaN	Green	1000	
	B	InGaN	Blue	335	

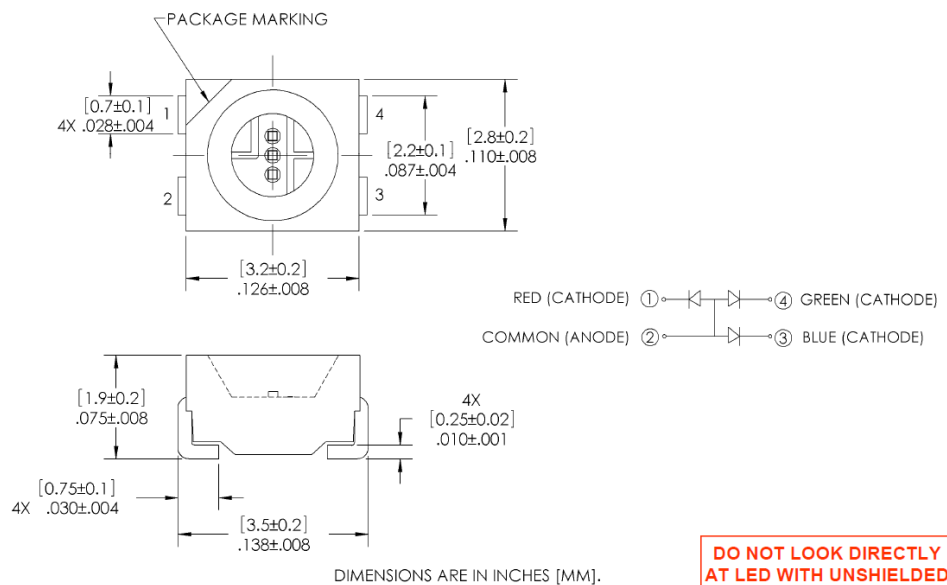

DO NOT LOOK DIRECTLY AT LED WITH UNSHIELDED EYES OR DAMAGE TO RETINA MAY OCCUR.

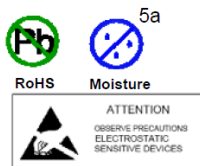

OPTEK reserves the right to make changes at any time in order to improve design and to supply the best product possible.

General Note

TT Electronics reserves the right to make changes in product specification without notice or liability. All information is subject to TT Electronics' own data and is considered accurate at time of going to print.

OPTEK Technology, Inc.
1645 Wallace Drive, Carrollton, TX 75006 | Ph: +1 972 323 2200
www.optekinc.com | www.ttelectronics.com

Full Color PLCC4 LED

OVSARGB4R8



Absolute Maximum Ratings

$T_A = 25^\circ\text{C}$ unless otherwise noted

PARAMETER	RATING			UNIT
	R	G	B	
Storage Temperature	-40 ~ +100			$^\circ\text{C}$
Operating Temperature	-40 ~ +100			$^\circ\text{C}$
Reverse Voltage	5			V
Continuous Forward Current (1 chip on)	50	25	25	mA
Peak Forward Current (10% Duty Cycle, $PW \leq 100 \mu\text{sec}$, 1 chip on)	200	100	100	mA
Power Dissipation	130	100	100	mW
Junction Temperature	110	110	110	$^\circ\text{C}$
Junction/ambient (1 chip on)	450	400	450	$^\circ\text{C/W}$
Junction/ambient (3 chips on)	650	580	680	$^\circ\text{C/W}$
Junction/solder point (1 chip on)	300	280	300	$^\circ\text{C/W}$
Junction/solder point (3 chips on)	450	430	480	$^\circ\text{C/W}$
Electrostatic Discharge Classification (JEDEC-JESD22-A114F)				Class 1C
Moisture Sensitivity Level (IPC/JEDEC J-STD-020C)				5a / 24 Hrs

Electrical Characteristics

$T_A = 25^\circ\text{C}$ unless otherwise noted

SYMBOL	PARAMETER	VALUES			UNIT	CONDITIONS	
			R	G			B
I_V	Luminous Intensity	Min	450	710	224	mcd	$I_F = 20 \text{ mA}$
		Typ	635	1000	335		
V_F	Forward Voltage	Typ	2.0	3.2	3.2	V	$I_F = 20 \text{ mA}$
		Max	2.6	4.0	4.0		
I_R	Reverse Current (max)		10	10	10	μA	$V_R = 5 \text{ V}$
λ_D	Dominant Wavelength		619-624	520-540	460-475	nm	$I_F = 20 \text{ mA}$
$2 \Theta_{1/2}$	50% Power Angle		120	120	120	deg	$I_F = 20 \text{ mA}$
$\Delta\lambda$	Spectral Radiation Bandwidth		24	38	28	nm	$I_F = 20 \text{ mA}$

OPTEK reserves the right to make changes at any time in order to improve design and to supply the best product possible

General Note

TT Electronics reserves the right to make changes in product specification without notice or liability. All information is subject to TT Electronics' own data and is considered accurate at time of going to print.

OPTEK Technology, Inc.
1645 Wallace Drive, Carrollton, TX 75006 | Ph: +1 972 323 2200
www.optekinc.com | www.ttelectronics.com

Full Color PLCC4 LED

OVSARGB4R8



Typical Electro-Optical Characteristics Curves

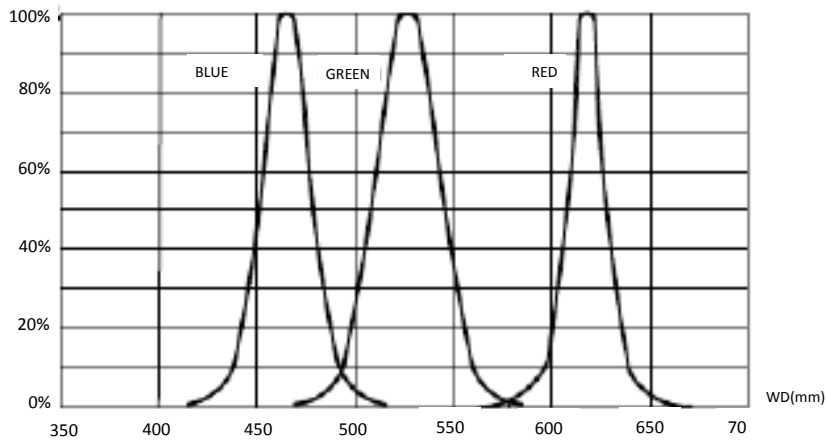

Relative Intensity vs Dominant Wavelength

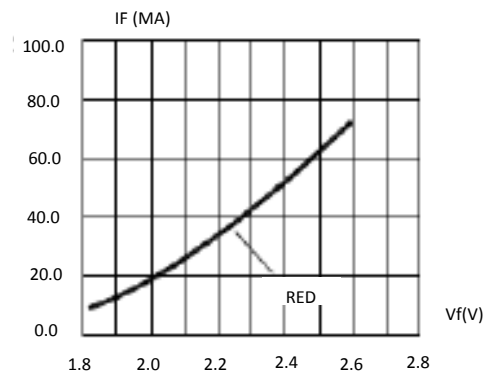
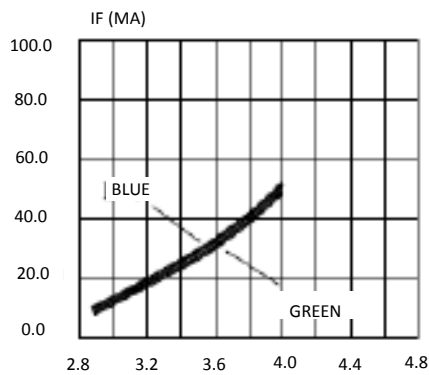

Forward Current vs Forward Voltage

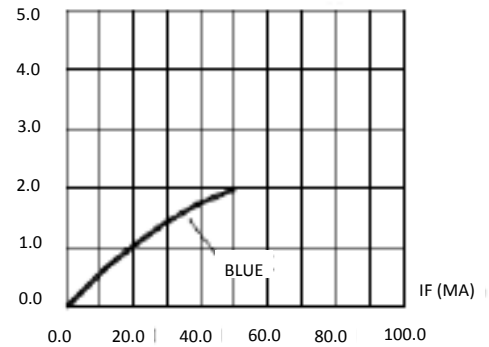
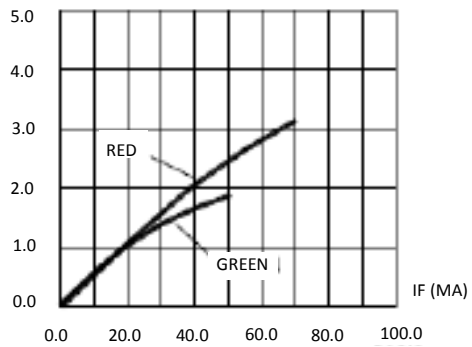

Relative Luminous Intensity vs Forward Current

OPTEK reserves the right to make changes at any time in order to improve design and to supply the best product possible

General Note
TT Electronics reserves the right to make changes in product specification without notice or liability. All information is subject to TT Electronics' own data and is considered accurate at time of going to print.

OPTEK Technology, Inc.
1645 Wallace Drive, Carrollton, TX 75006 | Ph: +1 972 323 2200
www.optekinc.com | www.ttelectronics.com

Full Color PLCC4 LED

OVSARGB4R8



Typical Electro-Optical Characteristics Curves

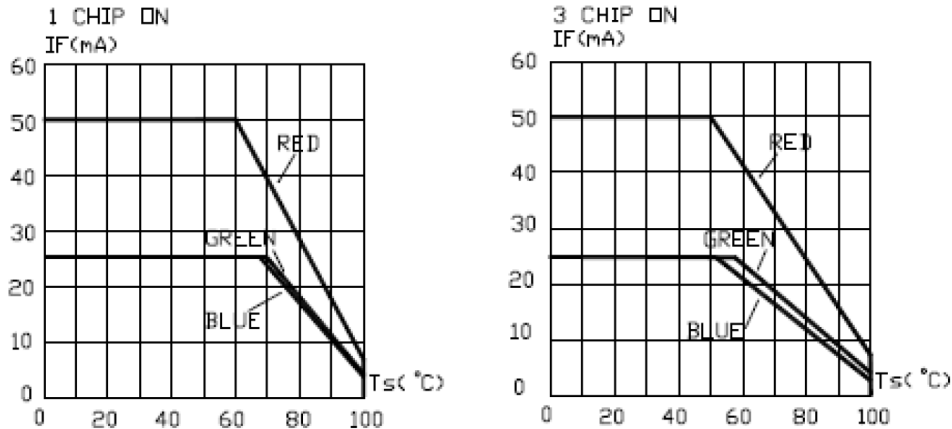

Maximum Forward DC Current vs Solder Point Temperature

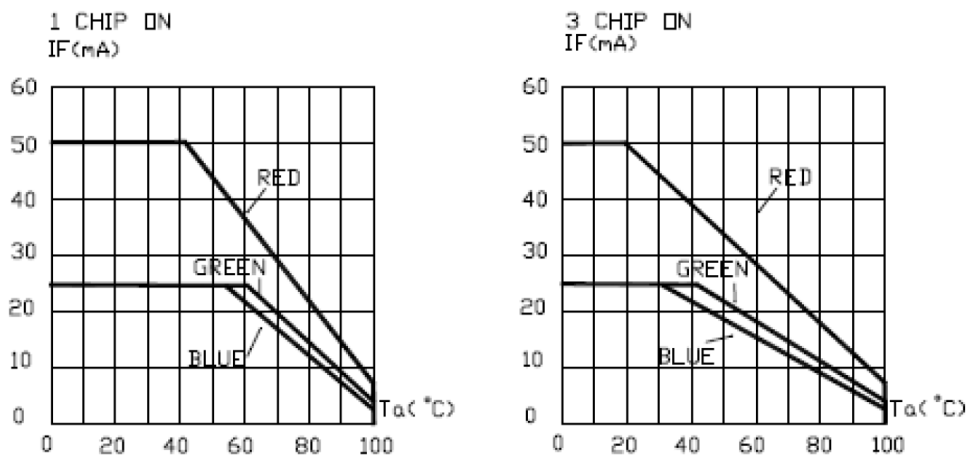

Maximum Forward DC Current vs Ambient Temperature

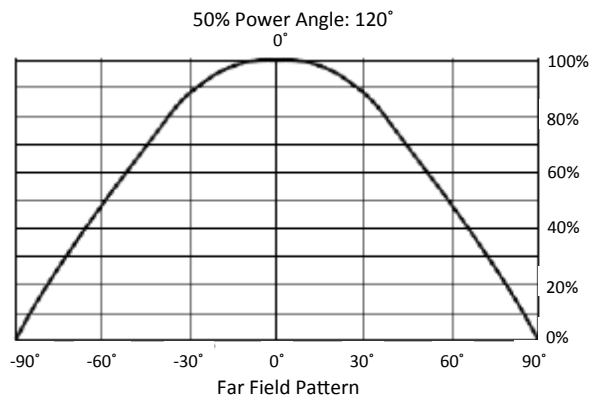

General Note

TT Electronics reserves the right to make changes in product specification without notice or liability. All information is subject to TT Electronics' own data and is considered accurate at time of going to print.

OPTEK Technology, Inc.
1645 Wallace Drive, Carrollton, TX 75006 | Ph: +1 972 323 2200
www.optekinc.com | www.ttelectronics.com

Reflow Solder Profile

Manual soldering by soldering iron

- The use of a soldering iron of less than 25W is recommended. The temperature of the iron must be kept at below 315°C with soldering time within 2 seconds
- The epoxy resin of the SMD LED should not contact the tip of the soldering iron
- No mechanical stress should be exerted on the resin portion of the SMD LED during soldering.
- Handling of the SMD LED should be done when the package has been cooled down to below 40°C or less. This is to prevent LED failures due to thermal-mechanical stress during handling.
- The temperature (top surface of the SMD LED) profile is as below:

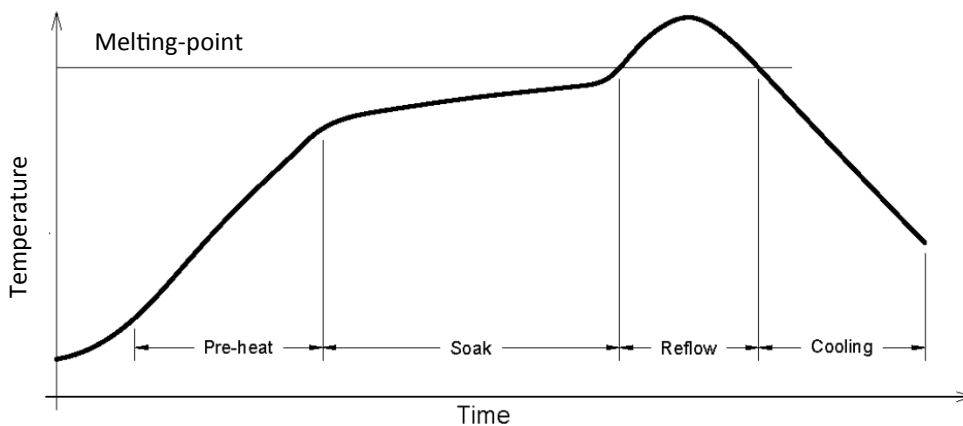

Solder = Lead-Free
Average ramp-up rate = 4°C / sec. max
Preheat temperature: 150 - 200°C
Preheat time: 120 sec. max.
Ramp-down rate = 6°C / sec. max.
Peak temperature = 250°C max.
Time within 5°C of actual peak temperature = 10 sec. max
Duration above 217°C is 60 sec. max

OPTEK reserves the right to make changes at any time in order to improve design and to supply the best product possible

General Note

TT Electronics reserves the right to make changes in product specification without notice or liability. All information is subject to TT Electronics' own data and is considered accurate at time of going to print.

OPTEK Technology, Inc.
1645 Wallace Drive, Carrollton, TX 75006 | Ph: +1 972 323 2200
www.optekinc.com | www.ttelectronics.com

Full Color PLCC4 LED

OVSARGB4R8



Reel Dimensions: 7-inch reel

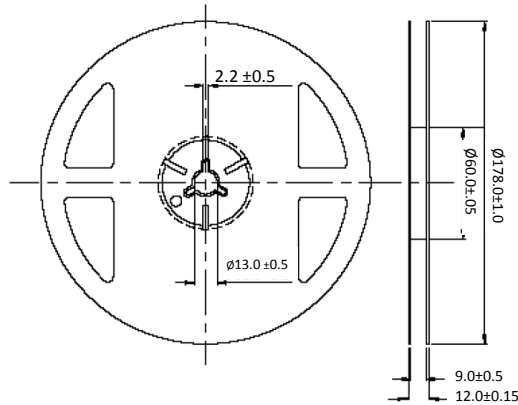

Carrier Tape Dimensions: Loaded quantity 2,000 pieces per reel

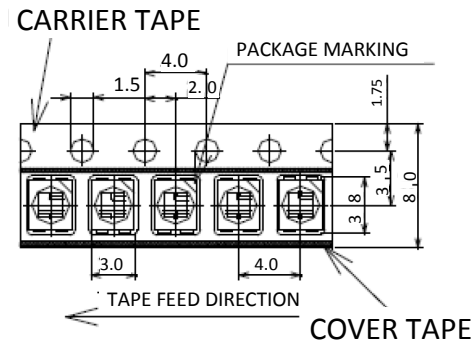

Moisture Resistant Packaging

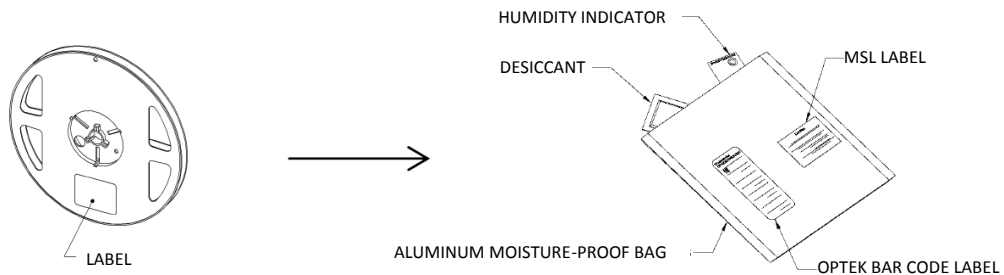

OPTEK reserves the right to make changes at any time in order to improve design and to supply the best product possible

General Note

TT Electronics reserves the right to make changes in product specification without notice or liability. All information is subject to TT Electronics' own data and is considered accurate at time of going to print.

OPTEK Technology, Inc.
1645 Wallace Drive, Carrollton, TX 75006 | Ph: +1 972 323 2200
www.optekinc.com | www.ttelectronics.com



Компания «ЭлектроПласт» предлагает заключение долгосрочных отношений при поставках импортных электронных компонентов на взаимовыгодных условиях!

Наши преимущества:

- Оперативные поставки широкого спектра электронных компонентов отечественного и импортного производства напрямую от производителей и с крупнейших мировых складов;
- Поставка более 17-ти миллионов наименований электронных компонентов;
- Поставка сложных, дефицитных, либо снятых с производства позиций;
- Оперативные сроки поставки под заказ (от 5 рабочих дней);
- Экспресс доставка в любую точку России;
- Техническая поддержка проекта, помощь в подборе аналогов, поставка прототипов;
- Система менеджмента качества сертифицирована по Международному стандарту ISO 9001;
- Лицензия ФСБ на осуществление работ с использованием сведений, составляющих государственную тайну;
- Поставка специализированных компонентов (Xilinx, Altera, Analog Devices, Intersil, Interpoint, Microsemi, Aeroflex, Peregrine, Syfer, Eurofarad, Texas Instrument, Miteq, Cobham, E2V, MA-COM, Hittite, Mini-Circuits, General Dynamics и др.);

Помимо этого, одним из направлений компании «ЭлектроПласт» является направление «Источники питания». Мы предлагаем Вам помощь Конструкторского отдела:

- Подбор оптимального решения, техническое обоснование при выборе компонента;
- Подбор аналогов;
- Консультации по применению компонента;
- Поставка образцов и прототипов;
- Техническая поддержка проекта;
- Защита от снятия компонента с производства.



Как с нами связаться

Телефон: 8 (812) 309 58 32 (многоканальный)

Факс: 8 (812) 320-02-42

Электронная почта: org@eplast1.ru

Адрес: 198099, г. Санкт-Петербург, ул. Калинина, дом 2, корпус 4, литера А.