

## Characteristics

| Parameter  | Rating | Units                  |
|--|--------|------------------------|
| AC Operating Voltage                               | 20-240 | $V_{rms}$              |
| Load Current                                       |        | $A_{rms}$              |
| With 5°C/W Heat Sink                               | 20     |                        |
| No Heat Sink                                       | 5      |                        |
| On-State Voltage Drop                              | 1.1    | $V_P$ (at $I_L=2A_P$ ) |
| Blocking Voltage                                   | 800    | $V_P$                  |
| Thermal Impedance, Junction-to-Case, $\theta_{JC}$ | 0.35   | °C/W                   |

## Features

- Load Current up to  $20A_{rms}$  with 5°C/W Heat Sink
- 800V<sub>P</sub> Blocking Voltage
- 5mA Control Current
- Zero-Cross Switching
- Isolated, Low Thermal Impedance Ceramic Pad for Heat Sink Applications
- 2500V<sub>rms</sub> Isolation, Input to Output
- DC Control, AC Output
- Optically Isolated
- Low EMI and RFI Generation
- High Noise Immunity
- Flammability Rating UL 94 V-0

## Applications

- Programmable Control
- Process Control
- Power Control Panels
- Remote Switching
- Gas Pump Electronics
- Contactors
- Large Relays
- Solenoids
- Motors
- Heaters

## Approvals

- UL 508 Recognized Component: File E69938

## Description

CPC1998J is an AC Solid State Switch utilizing dual power SCR outputs. This device also includes zero-cross turn-on circuitry and is specified with an 800V<sub>P</sub> blocking voltage.

Tightly controlled zero-cross circuitry ensures low noise switching of AC loads by minimizing the generation of transients. The optically coupled input and output circuits provide exceptional noise immunity and 2500V<sub>rms</sub> of isolation between the control and the output. As a result, the CPC1998 is well suited for industrial environments where electromagnetic interference would disrupt the operation of plant facility communications and control systems.

The unique i4-PAC package pioneered by IXYS allows Solid State Relays to achieve the highest load current and power ratings. This package features a unique IXYS process in which the silicon chips are soft soldered onto the Direct Copper Bond (DCB) substrate instead of the traditional copper leadframe. The DCB ceramic, the same substrate used in high power modules, not only provides 2500V<sub>rms</sub> isolation but also very low junction-to-case thermal impedance (0.35 °C/W).

## Ordering Information

| Part     | Description                  |
|----------|------------------------------|
| CPC1998J | i4-PAC Package (25 per tube) |

## Pin Configuration

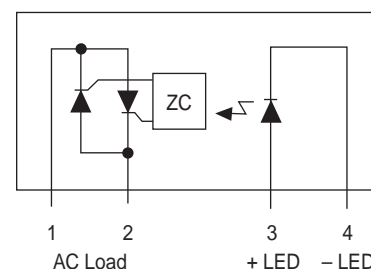

## 1 Specifications

### 1.1 Absolute Maximum Ratings @ 25°C

| Symbol   | Min  | Max  | Units            |
|--|------|------|------------------|
| Blocking Voltage                                     | -    | 800  | V <sub>P</sub>   |
| Reverse Input Voltage                                | -    | 5    | V                |
| Input Control Current                                | -    | 50   | mA               |
| Peak (10ms)  | -    | 1    | A                |
| Input Power Dissipation <sup>1</sup>                 | -    | 150  | mW               |
| Total Power Dissipation <sup>2</sup>                 | -    | 3.5  | W                |
| I <sup>2</sup> t for Fusing<br>(1/2 Sine Wave, 60Hz) | -    | 200  | A <sup>2</sup> s |
| Isolation Voltage, Input to Output                   | -    | 2500 | V <sub>rms</sub> |
| ESD, Human Body Model                                | -    | 8    | kV               |
| Operational Temperature                              | - 40 | +85  | °C               |
| Storage Temperature                                  | - 40 | +125 | °C               |

<sup>1</sup> Derate linearly 1.33mW / °C.

<sup>2</sup> Free air, no heat sink.

Absolute maximum ratings are stress ratings. Stresses in excess of these ratings can cause permanent damage to the device. Functional operation of the device at conditions beyond those indicated in the operational sections of this data sheet is not implied.

Typical values are characteristic of the device at +25°C, and are the result of engineering evaluations. They are provided for information purposes only, and are not part of the manufacturing testing requirements.

### 1.2 Electrical Characteristics @ 25°C

| Parameter   | Conditions   | Symbol            | Minimum | Typical | Maximum | Units            |
|---|--|-------------------|---------|---------|---------|------------------|
| <b>Output Characteristics</b>                         |  |                   |         |         |         |                  |
| Load Current  | No Heat Sink, V <sub>L</sub> =20-240V <sub>rms</sub><br>T <sub>C</sub> =25°C | I <sub>L</sub>    | 0.1     | -       | 5       | A <sub>rms</sub> |
| Continuous  |  |                   | 0.1     | -       | 50      |                  |
| Maximum Surge Current                                 | 1/2 Sine Wave, 60Hz  | I <sub>P</sub>    | -       | -       | 150     | A                |
| Off-State Leakage Current                             | V <sub>L</sub> =800V   | I <sub>LEAK</sub> | -       | -       | 100     | μA <sub>P</sub>  |
| On-State Voltage Drop <sup>1</sup>                    | I <sub>L</sub> =2A <sub>P</sub>  | -                 | -       | 0.85    | 1.1     | V <sub>P</sub>   |
| Off-State dV/dt                                       | I <sub>F</sub> =0mA  | dV/dt             | 1000    | -       | -       | V/μs             |
| Switching Speeds                                      | I <sub>F</sub> =5mA  | t <sub>on</sub>   | -       | -       | 0.5     | cycles           |
| Turn-On   |  | t <sub>off</sub>  | -       | -       | 0.5     |                  |
| Zero-Cross Turn-On Voltage <sup>2</sup>               | 1 <sup>st</sup> half-cycle   | -                 | -       | 5       | 20      | V                |
|   | subsequent half-cycle  | -                 | -       | -       | 5       |                  |
| Holding Current                                       | -  | I <sub>H</sub>    | -       | 44      | 50      | mA               |
| Latching Current                                      | -  | I <sub>L</sub>    | -       | 48      | 75      | mA               |
| Operating Frequency                                   | -  | -                 | 20      | -       | 500     | Hz               |
| Load Power Factor for Guaranteed Turn-On <sup>3</sup> | f=60Hz   | PF                | 0.25    | -       | -       | -                |
| <b>Input Characteristics</b>                          |  |                   |         |         |         |                  |
| Input Control Current to Activate <sup>4</sup>        | I <sub>L</sub> =1A Resistive, f=60Hz   | I <sub>F</sub>    | -       | -       | 5       | mA               |
| Input Dropout Voltage                                 | -  | -                 | 0.8     | -       | -       | V                |
| Input Voltage Drop                                    | I <sub>F</sub> =5mA  | V <sub>F</sub>    | 0.9     | 1.2     | 1.5     | V                |
| Reverse Input Current                                 | V <sub>R</sub> =5V   | I <sub>R</sub>    | -       | -       | 10      | μA               |
| <b>Input/Output Characteristics</b>                   |  |                   |         |         |         |                  |
| Capacitance, Input-to-Output                          | V <sub>IO</sub> =0V, f=1MHz  | C <sub>IO</sub>   | -       | -       | 3       | pF               |

<sup>1</sup> Tested at a peak value equivalent.

<sup>2</sup> Zero-cross first half-cycle @ < 100Hz.

<sup>3</sup> Snubber circuits may be required at low power factors.

<sup>4</sup> For high-noise environments, or high-frequency operation (>60Hz), or for applications with a high inductive load, a minimum LED drive current of 10mA is recommended.

## 2 Thermal Characteristics

| Parameter                               | Conditions | Symbol        | Rating      | Units                       |
|---|------------|---------------|-------------|-----------------------------|
| Thermal Impedance (Junction to Case)    | -          | $\theta_{JC}$ | 0.35        | $^{\circ}\text{C}/\text{W}$ |
| Thermal Impedance (Junction to Ambient) | Free Air   | $\theta_{JA}$ | 33          | $^{\circ}\text{C}/\text{W}$ |
| Junction Temperature (Operating)        | -          | $T_J$         | -40 to +125 | $^{\circ}\text{C}$          |

### 2.1 Thermal Management

Device high current characterization was performed using Kunze heat sink KU 1-159, phase change thermal interface material KU-ALC 5, and transistor clip KU 4-499/1. This combination provided an approximate junction-to-ambient thermal impedance of  $12.5^{\circ}\text{C}/\text{W}$ .

### 2.2 Heat Sink Calculation

Higher load currents are possible by using lower thermal impedance heat sink combinations.

#### Heat Sink Rating

$$\theta_{CA} = \frac{(T_J - T_A)}{P_D} - \theta_{JC}$$

$T_J$  = Junction Temperature ( $^{\circ}\text{C}$ ),  $T_J \leq 125^{\circ}\text{C}$  \*

$T_A$  = Ambient Temperature ( $^{\circ}\text{C}$ )

$\theta_{JC}$  = Thermal Impedance, Junction to Case ( $^{\circ}\text{C}/\text{W}$ ) =  $0.35^{\circ}\text{C}/\text{W}$

$\theta_{CA}$  = Thermal Impedance of Heat Sink & Thermal Interface Material, Case to Ambient ( $^{\circ}\text{C}/\text{W}$ )

$P_D$  = On-State Voltage ( $V_{rms}$ ) • Load Current ( $A_{rms}$ )

\* Elevated junction temperature reduces semiconductor lifetime.

**NOTE:** The exposed surface of the DCB substrate is not to be soldered.

### 2.3 Thermal Performance Data

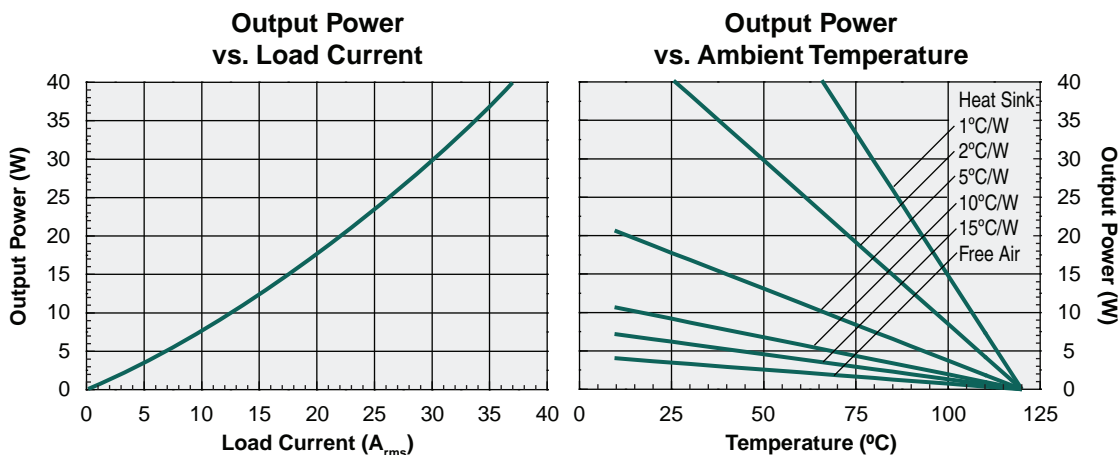

### 3 Performance Data\*

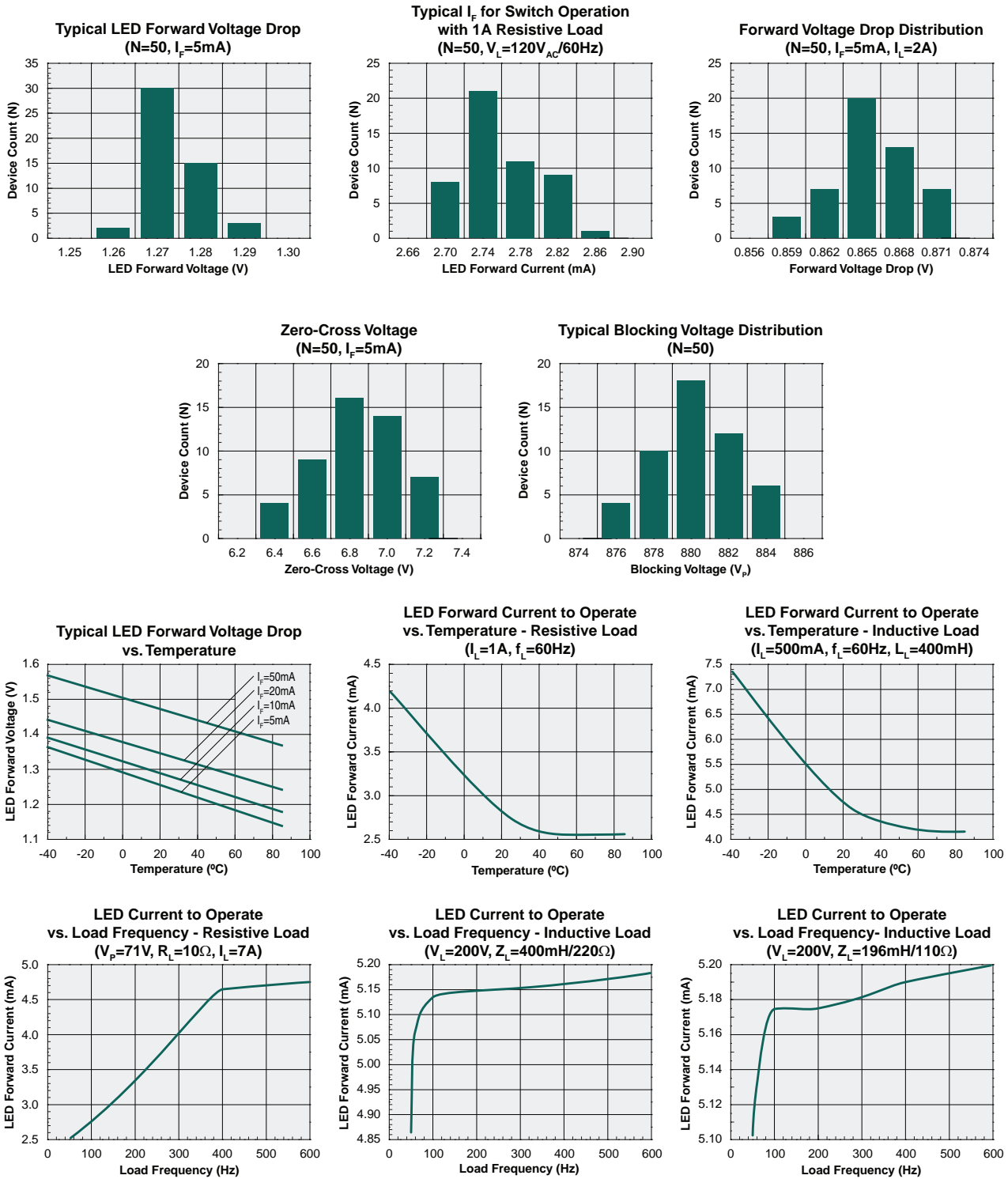

\*Unless otherwise noted, data presented in these graphs is typical of device operation at 25°C. For guaranteed parameters not indicated in the written specifications, please contact our application department.

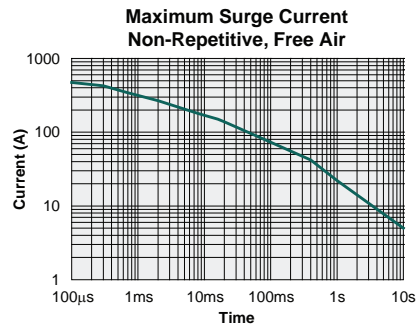
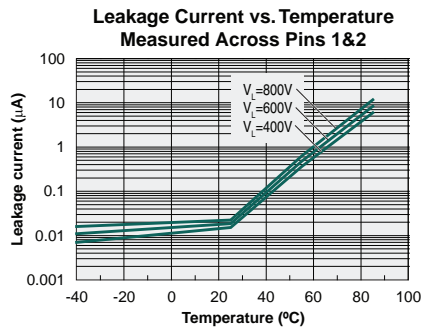
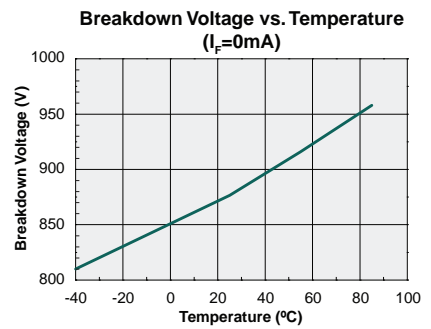
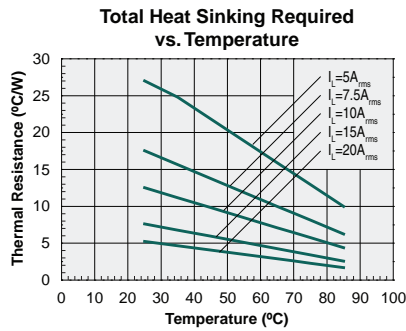
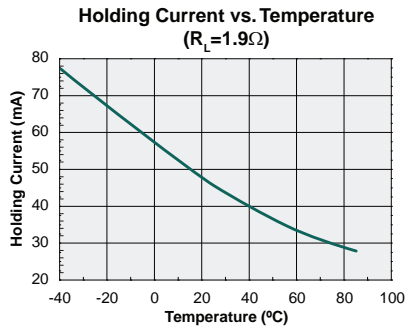
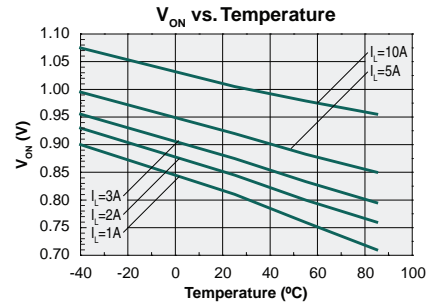
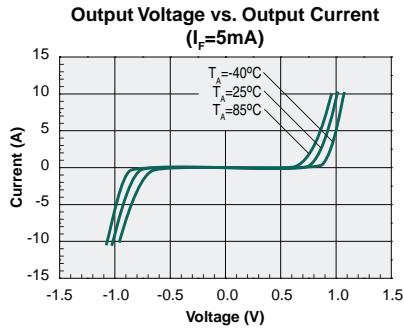
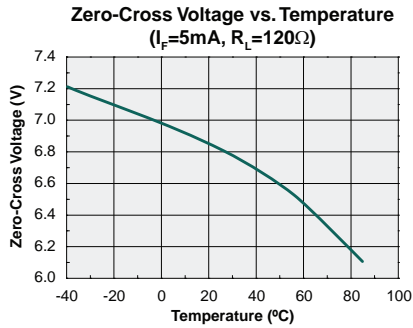

\*Unless otherwise noted, data presented in these graphs is typical of device operation at 25°C.  
For guaranteed parameters not indicated in the written specifications, please contact our application department.

## 4 Manufacturing Information

### 4.1 Moisture Sensitivity



All plastic encapsulated semiconductor packages are susceptible to moisture ingress. IXYS Integrated Circuits classifies its plastic encapsulated devices for moisture sensitivity according to the latest version of the joint industry standard, **IPC/JEDEC J-STD-020**, in force at the time of product evaluation. We test all of our products to the maximum conditions set forth in the standard, and guarantee proper operation of our devices when handled according to the limitations and information in that standard as well as to any limitations set forth in the information or standards referenced below.

Failure to adhere to the warnings or limitations as established by the listed specifications could result in reduced product performance, reduction of operable life, and/or reduction of overall reliability.

This product carries a **Moisture Sensitivity Level (MSL)** classification as shown below, and should be handled according to the requirements of the latest version of the joint industry standard **IPC/JEDEC J-STD-033**.

| Device   | Moisture Sensitivity Level (MSL) Classification |
|----------|---|
| CPC1998J | MSL 1   |

### 4.2 ESD Sensitivity



This product is **ESD Sensitive**, and should be handled according to the industry standard **JESD-625**.

### 4.3 Soldering Profile

Provided in the table below is the Classification Temperature ( $T_C$ ) of this product and the maximum dwell time the body temperature of this device may be ( $T_C - 5$ )°C or greater. The classification temperature sets the Maximum Body Temperature allowed for this device during lead-free reflow processes. For through-hole devices, and any other processes, the guidelines of **J-STD-020** must be observed.

| Device   | Classification Temperature ( $T_C$ ) | Dwell Time ( $t_p$ ) | Max Reflow Cycles |
|----------|--------------------------------------|----------------------|-------------------|
| CPC1998J | 245°C                                | 30 seconds           | 1                 |

**NOTE:** The exposed surface of the DCB substrate is not to be soldered.

### 4.4 Board Wash

IXYS Integrated Circuits recommends the use of no-clean flux formulations. Board washing to reduce or remove flux residue following the solder reflow process is acceptable provided proper precautions are taken to prevent damage to the device. These precautions include but are not limited to: using a low pressure wash and providing a follow up bake cycle sufficient to remove any moisture trapped within the device due to the washing process. Due to the variability of the wash parameters used to clean the board, determination of the bake temperature and duration necessary to remove the moisture trapped within the package is the responsibility of the user (assembler). Cleaning or drying methods that employ ultrasonic energy may damage the device and should not be used. Additionally, the device must not be exposed to flux or solvents that are Chlorine- or Fluorine-based.



**4.5 Mechanical Dimensions**

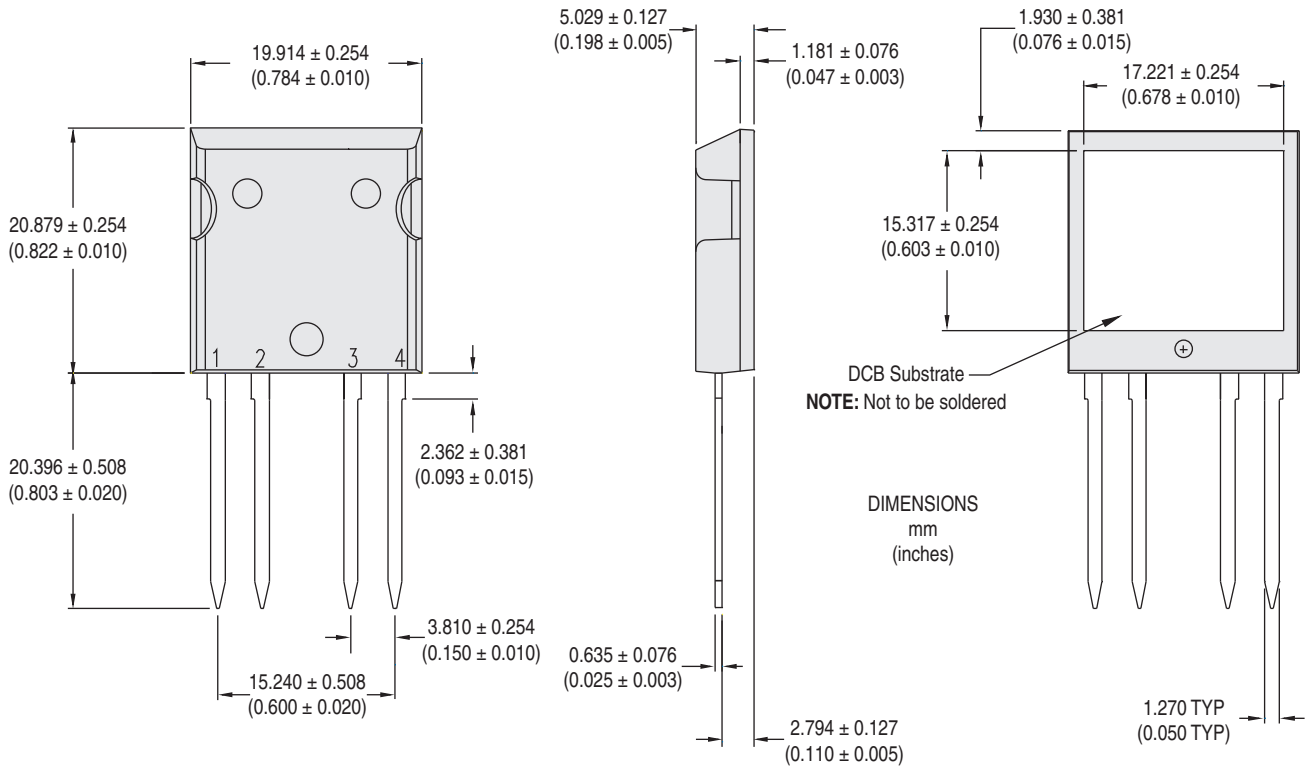

**NOTE:** Metallized external surface of DCB substrate maintains 2500V<sub>rms</sub> isolation to device internal structure and all external pins.

**For additional information please visit our website at: [www.ixysic.com](http://www.ixysic.com)**

IXYS Integrated Circuits makes no representations or warranties with respect to the accuracy or completeness of the contents of this publication and reserves the right to make changes to specifications and product descriptions at any time without notice. Neither circuit patent licenses nor indemnity are expressed or implied. Except as set forth in IXYS Integrated Circuits' Standard Terms and Conditions of Sale, IXYS Integrated Circuits assumes no liability whatsoever, and disclaims any express or implied warranty, relating to its products including, but not limited to, the implied warranty of merchantability, fitness for a particular purpose, or infringement of any intellectual property right.

The products described in this document are not designed, intended, authorized or warranted for use as components in systems intended for surgical implant into the body, or in other applications intended to support or sustain life, or where malfunction of IXYS Integrated Circuits' product may result in direct physical harm, injury, or death to a person or severe property or environmental damage. IXYS Integrated Circuits reserves the right to discontinue or make changes to its products at any time without notice.

Specification: DS-CPC1998-R06  
©Copyright 2018, IXYS Integrated Circuits  
All rights reserved. Printed in USA.  
6/29/2018



Компания «ЭлектроПласт» предлагает заключение долгосрочных отношений при поставках импортных электронных компонентов на взаимовыгодных условиях!

Наши преимущества:

- Оперативные поставки широкого спектра электронных компонентов отечественного и импортного производства напрямую от производителей и с крупнейших мировых складов;
- Поставка более 17-ти миллионов наименований электронных компонентов;
- Поставка сложных, дефицитных, либо снятых с производства позиций;
- Оперативные сроки поставки под заказ (от 5 рабочих дней);
- Экспресс доставка в любую точку России;
- Техническая поддержка проекта, помощь в подборе аналогов, поставка прототипов;
- Система менеджмента качества сертифицирована по Международному стандарту ISO 9001;
- Лицензия ФСБ на осуществление работ с использованием сведений, составляющих государственную тайну;
- Поставка специализированных компонентов (Xilinx, Altera, Analog Devices, Intersil, Interpoint, Microsemi, Aeroflex, Peregrine, Syfer, Eurofarad, Texas Instrument, Miteq, Cobham, E2V, MA-COM, Hittite, Mini-Circuits, General Dynamics и др.);

Помимо этого, одним из направлений компании «ЭлектроПласт» является направление «Источники питания». Мы предлагаем Вам помощь Конструкторского отдела:

- Подбор оптимального решения, техническое обоснование при выборе компонента;
- Подбор аналогов;
- Консультации по применению компонента;
- Поставка образцов и прототипов;
- Техническая поддержка проекта;
- Защита от снятия компонента с производства.



#### Как с нами связаться

**Телефон:** 8 (812) 309 58 32 (многоканальный)

**Факс:** 8 (812) 320-02-42

**Электронная почта:** [org@eplast1.ru](mailto:org@eplast1.ru)

**Адрес:** 198099, г. Санкт-Петербург, ул. Калинина, дом 2, корпус 4, литера А.