



# Rectangular 10 Turn Dial (3 Digit), (4 Digit) 100 Turn



## FEATURES

- Rectangular digital scale
- 1" wide
- 1/4" or 1/8" or metric (6 mm) shaft adapter
- Open or clear plastic window bezel
- Black anodize finish with standard or white bezel trim
- Satin clear anodize finish
- Material categorization: For definitions of compliance please see [www.vishay.com/doc?99912](http://www.vishay.com/doc?99912)



RoHS  
COMPLIANT

QUICK REFERENCE DATA	
Sensor type	DIALS
Market appliance	Industrial
Dimensions	25.4 mm x 49.5 mm

MECHANICAL SPECIFICATIONS	
PARAMETER	
Numerals	The numerals shall be white on a black background and 0.130" H (3.30 cm)
Mounting	The spring detented knob shall be removed using a straight pull, exposing two no. 4 to 40 hex socket set screws for mounting the dial directly to the component shaft
Weight	1.6 oz. (45.36 g)

OPERATIONAL SPECIFICATIONS	
Operation 3 digit (10 turn) Left digit Right two digits	Complete revolutions of turning knob Percent of revolution The unit registers a total count of 999
Operation 4 digit (100 turn) Left two digits Right two digits	Complete revolutions of turning knob Percent of revolution The unit registers a total count of 9999
Rotation	The indication shall increase with clockwise rotation of the turning knob
Accuracy	Graduation lines adjacent to the numerals on the right digit wheel indicate settings 0.2 % of a revolution of the turning knob
Phasing	Dial phased by rotating the exposed component shaft to correspond with the desired reading on the dial prior to tightening the set screws

## DIMENSIONS in inches (millimeters)

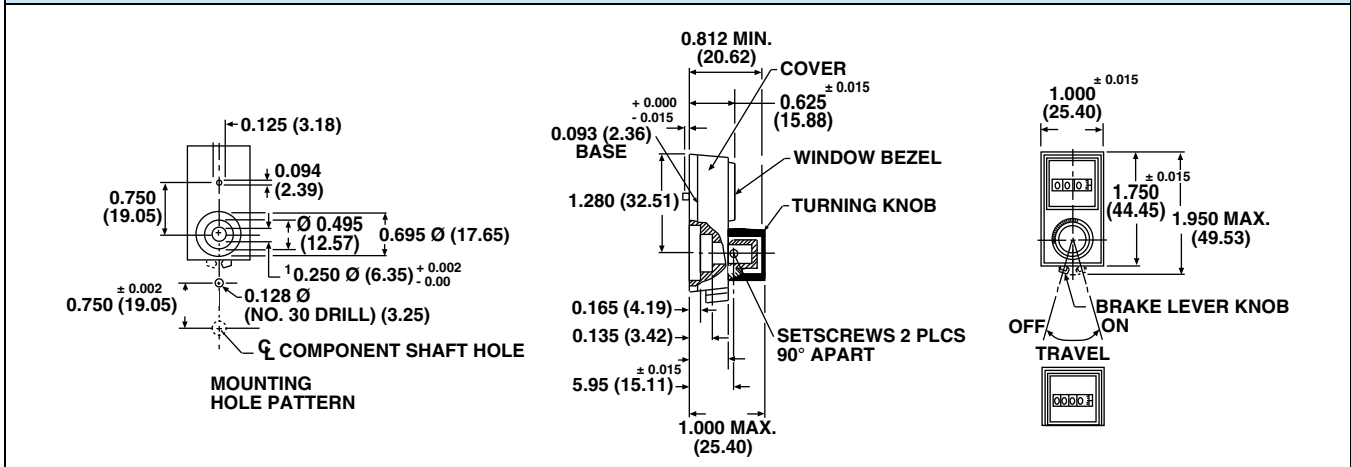

## ORDERING INFORMATION/DESCRIPTION

15	A	1	1	B010	e
MODEL	SHAFT DIAMETER AND NUMERICAL DISPLAY	BEZEL	FINISH	PACKAGING	LEAD FINISH
Example: 15 - A - 1 - 1	<p>A 1/4" dia. 3 digit</p> <p>B 1/4" dia. 4 digit</p> <p>C 1/8" dia. 3 digit</p> <p>D 1/8" dia. 4 digit</p> <p>E 6 mm dia. 3 digit</p> <p>F 6 mm dia. 4 digit</p>	<p>1. Open</p> <p>3. Clear plastic window</p>	<p>1. Satin clear anodize</p> <p>3. Black anodize, white bezel trim</p> <p>5. Black anodize</p>		

## SAP PART NUMBERING GUIDELINES

15	A	1	1	B10
MODEL	SHAFT DIAMETER	BEZEL	FINISH	PACKAGING



## Disclaimer

ALL PRODUCT, PRODUCT SPECIFICATIONS AND DATA ARE SUBJECT TO CHANGE WITHOUT NOTICE TO IMPROVE RELIABILITY, FUNCTION OR DESIGN OR OTHERWISE.

Vishay Intertechnology, Inc., its affiliates, agents, and employees, and all persons acting on its or their behalf (collectively, "Vishay"), disclaim any and all liability for any errors, inaccuracies or incompleteness contained in any datasheet or in any other disclosure relating to any product.

Vishay makes no warranty, representation or guarantee regarding the suitability of the products for any particular purpose or the continuing production of any product. To the maximum extent permitted by applicable law, Vishay disclaims (i) any and all liability arising out of the application or use of any product, (ii) any and all liability, including without limitation special, consequential or incidental damages, and (iii) any and all implied warranties, including warranties of fitness for particular purpose, non-infringement and merchantability.

Statements regarding the suitability of products for certain types of applications are based on Vishay's knowledge of typical requirements that are often placed on Vishay products in generic applications. Such statements are not binding statements about the suitability of products for a particular application. It is the customer's responsibility to validate that a particular product with the properties described in the product specification is suitable for use in a particular application. Parameters provided in datasheets and/or specifications may vary in different applications and performance may vary over time. All operating parameters, including typical parameters, must be validated for each customer application by the customer's technical experts. Product specifications do not expand or otherwise modify Vishay's terms and conditions of purchase, including but not limited to the warranty expressed therein.

Except as expressly indicated in writing, Vishay products are not designed for use in medical, life-saving, or life-sustaining applications or for any other application in which the failure of the Vishay product could result in personal injury or death. Customers using or selling Vishay products not expressly indicated for use in such applications do so at their own risk. Please contact authorized Vishay personnel to obtain written terms and conditions regarding products designed for such applications.

No license, express or implied, by estoppel or otherwise, to any intellectual property rights is granted by this document or by any conduct of Vishay. Product names and markings noted herein may be trademarks of their respective owners.

## Material Category Policy

**Vishay Intertechnology, Inc. hereby certifies that all its products that are identified as RoHS-Compliant fulfill the definitions and restrictions defined under Directive 2011/65/EU of The European Parliament and of the Council of June 8, 2011 on the restriction of the use of certain hazardous substances in electrical and electronic equipment (EEE) - recast, unless otherwise specified as non-compliant.**

**Please note that some Vishay documentation may still make reference to RoHS Directive 2002/95/EC. We confirm that all the products identified as being compliant to Directive 2002/95/EC conform to Directive 2011/65/EU.**

**Vishay Intertechnology, Inc. hereby certifies that all its products that are identified as Halogen-Free follow Halogen-Free requirements as per JEDEC JS709A standards. Please note that some Vishay documentation may still make reference to the IEC 61249-2-21 definition. We confirm that all the products identified as being compliant to IEC 61249-2-21 conform to JEDEC JS709A standards.**



Компания «ЭлектроПласт» предлагает заключение долгосрочных отношений при поставках импортных электронных компонентов на взаимовыгодных условиях!

Наши преимущества:

- Оперативные поставки широкого спектра электронных компонентов отечественного и импортного производства напрямую от производителей и с крупнейших мировых складов;
- Поставка более 17-ти миллионов наименований электронных компонентов;
- Поставка сложных, дефицитных, либо снятых с производства позиций;
- Оперативные сроки поставки под заказ (от 5 рабочих дней);
- Экспресс доставка в любую точку России;
- Техническая поддержка проекта, помощь в подборе аналогов, поставка прототипов;
- Система менеджмента качества сертифицирована по Международному стандарту ISO 9001;
- Лицензия ФСБ на осуществление работ с использованием сведений, составляющих государственную тайну;
- Поставка специализированных компонентов (Xilinx, Altera, Analog Devices, Intersil, Interpoint, Microsemi, Aeroflex, Peregrine, Syfer, Eurofarad, Texas Instrument, Miteq, Cobham, E2V, MA-COM, Hittite, Mini-Circuits, General Dynamics и др.);

Помимо этого, одним из направлений компании «ЭлектроПласт» является направление «Источники питания». Мы предлагаем Вам помощь Конструкторского отдела:

- Подбор оптимального решения, техническое обоснование при выборе компонента;
- Подбор аналогов;
- Консультации по применению компонента;
- Поставка образцов и прототипов;
- Техническая поддержка проекта;
- Защита от снятия компонента с производства.



#### Как с нами связаться

**Телефон:** 8 (812) 309 58 32 (многоканальный)

**Факс:** 8 (812) 320-02-42

**Электронная почта:** [org@eplast1.ru](mailto:org@eplast1.ru)

**Адрес:** 198099, г. Санкт-Петербург, ул. Калинина, дом 2, корпус 4, литера А.