

# MAXIM

## MAX1797 Evaluation Kit

### General Description

The MAX1797 evaluation kit (EV kit) is a high-efficiency, step-up DC-DC converter for portable hand-held devices. Unlike typical boost circuits, the MAX1797 output is completely disconnected from the input in shutdown. The EV kit accepts a positive input voltage between 0.7V and  $V_{OUT}$  and converts it to a 3.3V output for currents up to 500mA. The EV kit provides ultra-low quiescent current and high efficiency for maximum battery life.

The MAX1797 EV kit is a fully assembled and tested surface-mount printed circuit (PC) board. It can also be used to evaluate other output voltages in the 2V to 5.5V range. Additional pads on the board accommodate the external feedback resistors for setting different output voltages.

### Component Suppliers

SUPPLIER	PHONE	FAX
AVX	803-946-0690	803-626-3123
Sprague	603-224-1961	603-224-1430
Sumida	847-956-0666	847-956-0702

**Note:** Please indicate that you are using the MAX1797 when contacting these component suppliers

### Component List

DESIGNATION	QTY	DESCRIPTION
C1, C2	2	47 $\mu$ F, 16V tantalum capacitors AVX TPSD476M016R0150 or Sprague 593D476X0016D
C3	1	0.1 $\mu$ F ceramic capacitor (1206)
L1	1	22 $\mu$ H, 1.2A inductor Sumida CDRH6D28-220NC
R1, R2, R4, R5	0	Not installed
R3	1	1M $\Omega$ $\pm$ 1% resistor (1206)
U1	1	MAX1797EUA (8-pin $\mu$ MAX)
JU1	1	3-pin header
None	1	Shunt
None	1	MAX1797 PC board
None	1	MAX1797EVKIT data sheet
None	1	MAX1797 data sheet

### Features

- ◆ Output Disconnects from Input During Shutdown
- ◆ Operates Down to 0.7V Input Supply Voltage
- ◆ Adjustable Output Voltage (2V to 5.5V, External Divider)
- ◆ Up to 500mA Output Current
- ◆ No External Schottky Diode Required
- ◆ Synchronous Rectification for Improved Efficiency
- ◆ Damping Circuit Reduces EMI
- ◆ 1 $\mu$ A (typ) Shutdown Current
- ◆ Low-Battery Detector (LBI/LBO)
- ◆ 8-Pin  $\mu$ MAX Package
- ◆ Surface-Mount Construction
- ◆ Fully Assembled and Tested

### Ordering Information

PART	TEMP. RANGE	IC PACKAGE
MAX1797EVKIT	0°C to +70°C	8 $\mu$ MAX

**Note:** To evaluate the MAX1795 or MAX1796, request a free sample of the MAX1795EUA or MAX1796EUA along with the MAX1797 EV kit.

### Quick Start

The MAX1797 EV kit is a fully assembled and tested surface-mount board. Follow the steps below to verify board operation. **Do not turn on the power supply until all connections are completed:**

- 1) Connect a voltmeter and load (if any) to the  $V_{OUT}$  pad.
- 2) Verify that the shunt is across JU1 pins 2 and 3.
- 3) Connect a 2V supply to the pads marked VIN and GND.
- 4) Turn on the power and verify that the output voltage is 3.3V.
- 5) See the *Output Voltage Selection* section to modify the board for a different output voltage.

Evaluates: MAX1795/MAX1796/MAX1797

# MAX1797 Evaluation Kit

## Detailed Description

### Input Source

The input source for the MAX1797 EV kit must be greater than 1.0V for guaranteed startup (0.7V for operation once started), and less than the output voltage. A typical input voltage range would be the 2.0V to 3.3V range of a 2-cell NiCd battery. An input voltage greater than the selected output voltage (but less than 6V) will not damage the circuit; however, the MAX1797 output will nearly equal the input voltage when the device is not shutdown. In shutdown, the output is high impedance, and the output voltage will be 0V if a load is present. If OUT is driven by another voltage source, such as a backup battery, when the MAX1797 is shut down, the IC presents no load to the backup source.

Once started, the MAX1797 operates from the regulated output voltage. This means that the input voltage can fall below the 1.0V minimum guaranteed startup voltage. Typically, the regulated output will be maintained even if the input voltage drops to 0.7V.

### Shutdown Jumper Selection

The MAX1797 EV kit features a shutdown mode that reduces quiescent current to  $<1\mu\text{A}$  to preserve battery life. In shutdown, the output of the boost converter goes to high impedance and is fully disconnected from the input.

### Using the Low-Battery Detector

The MAX1797 has an additional comparator useful for monitoring the input source's voltage level. Resistors R4 and R5 are connected as a voltage-divider between the VIN pad and the MAX1797 LBI pin. Note that a PC trace

across R5 shorts the LBI pin to VIN when this function is not used. Cut the trace before installing R5. Refer to the *Low-Battery Detection* section of the MAX1797 data sheet for instructions on selecting values for R4 and R5.

### Output Voltage Selection

The MAX1797 is initially set for a 3.3V output by connecting the FB pin to OUT, or set to 5V by connecting the FB pin to GND. However, by adding external resistors R1 and R2, the output can be adjustable from 2.0V to 5.5V. Cut the trace shorting resistor R1, and install output voltage-divider resistors R1 and R2. The *Selecting the Output Voltage* section of the MAX1797 data sheet gives instruction for calculating R1 and R2 values.

**Table 1. Jumper JU1 Functions (Shutdown Mode)**

SHUNT LOCATION	SHDN PIN	MAX1797 OUTPUT
1 and 2	Connected to VIN, SHDN = high	Shutdown mode, $V_{\text{OUT}} = 0$
2 and 3	Connected to GND, SHDN = low	MAX1797 enabled, $V_{\text{OUT}} = 3.3\text{V}$

# MAX1797 Evaluation Kit

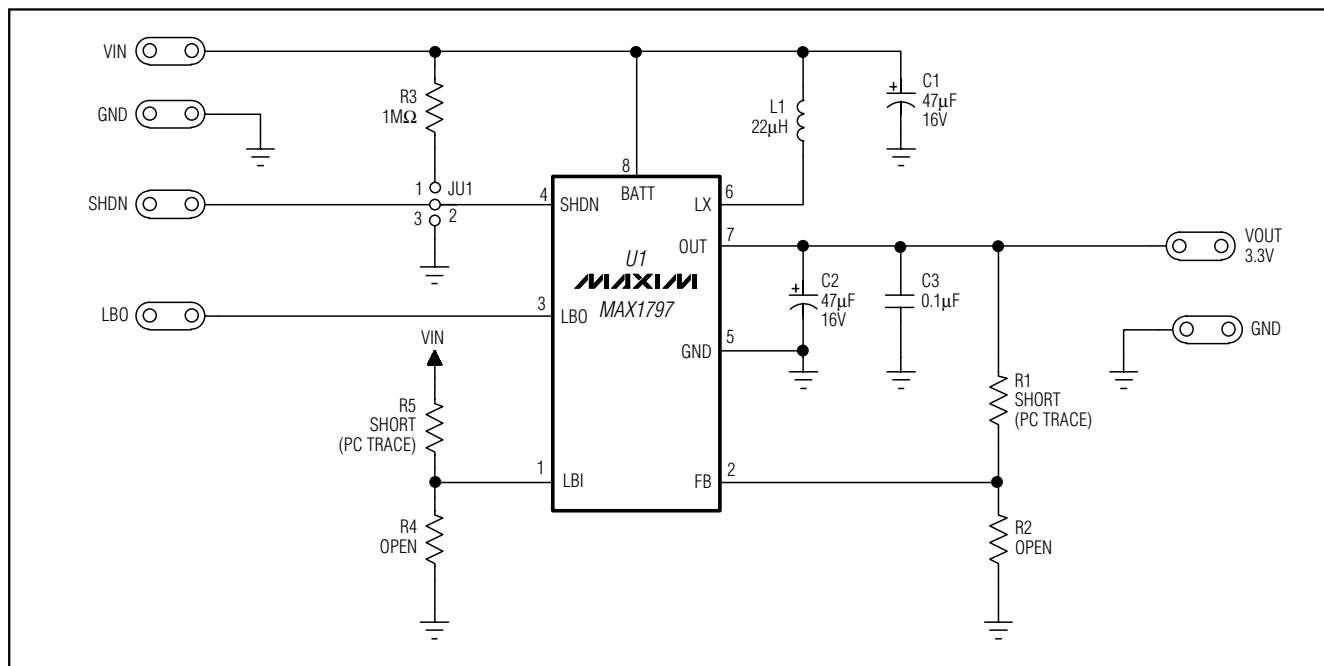

Figure 1. MAX1797 EV Kit Schematic

Evaluates: MAX1795/MAX1796/MAX1797

# MAX1797 Evaluation Kit

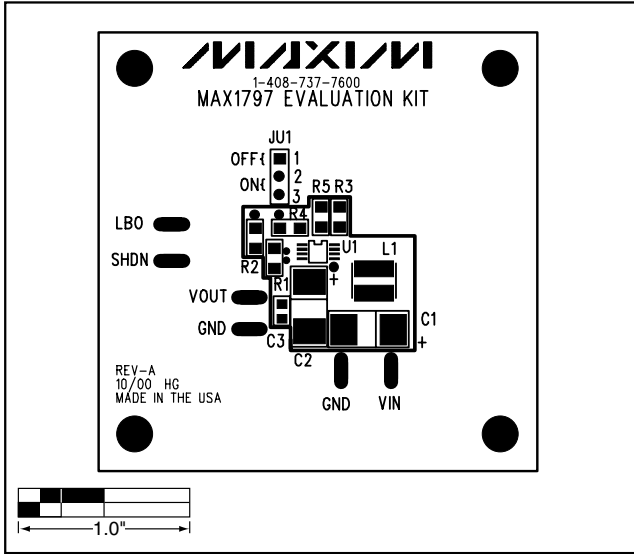

Figure 2. MAX1797 EV Kit Component Placement Guide—Top Silkscreen

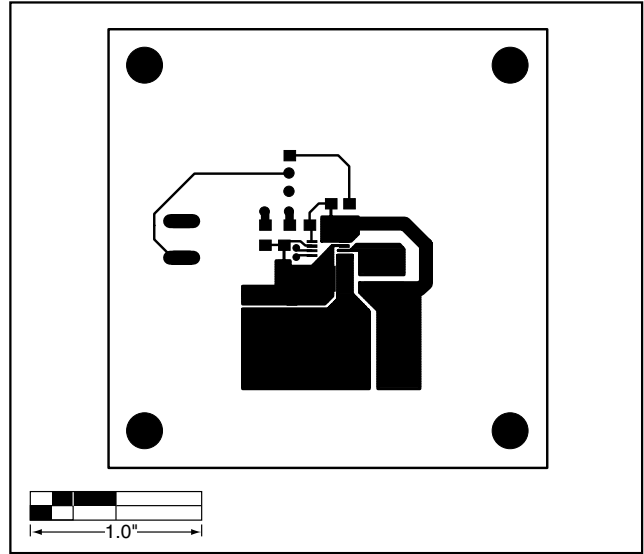

Figure 3. MAX1797 EV Kit PC Board Layout—Component Side

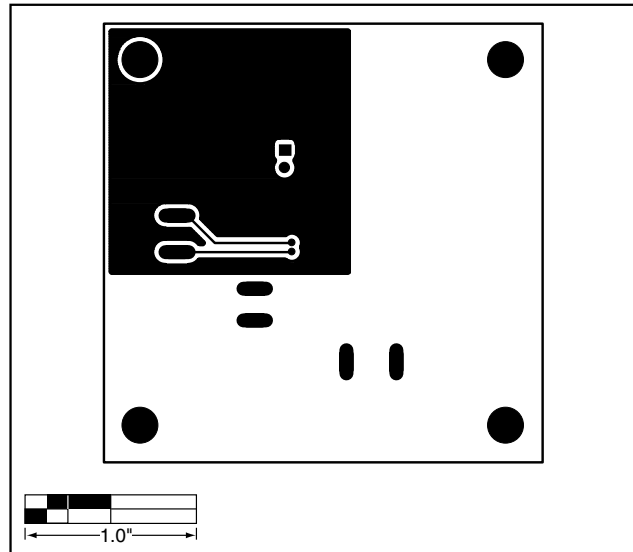

Figure 4. MAX1797 EV Kit PC Board Layout—Solder Side

Maxim cannot assume responsibility for use of any circuitry other than circuitry entirely embodied in a Maxim product. No circuit patent licenses are implied. Maxim reserves the right to change the circuitry and specifications without notice at any time.

4 \_\_\_\_\_ **Maxim Integrated Products, 120 San Gabriel Drive, Sunnyvale, CA 94086 408-737-7600**



Компания «ЭлектроПласт» предлагает заключение долгосрочных отношений при поставках импортных электронных компонентов на взаимовыгодных условиях!

Наши преимущества:

- Оперативные поставки широкого спектра электронных компонентов отечественного и импортного производства напрямую от производителей и с крупнейших мировых складов;
- Поставка более 17-ти миллионов наименований электронных компонентов;
- Поставка сложных, дефицитных, либо снятых с производства позиций;
- Оперативные сроки поставки под заказ (от 5 рабочих дней);
- Экспресс доставка в любую точку России;
- Техническая поддержка проекта, помощь в подборе аналогов, поставка прототипов;
- Система менеджмента качества сертифицирована по Международному стандарту ISO 9001;
- Лицензия ФСБ на осуществление работ с использованием сведений, составляющих государственную тайну;
- Поставка специализированных компонентов (Xilinx, Altera, Analog Devices, Intersil, Interpoint, Microsemi, Aeroflex, Peregrine, Syfer, Eurofarad, Texas Instrument, Miteq, Cobham, E2V, MA-COM, Hittite, Mini-Circuits, General Dynamics и др.);

Помимо этого, одним из направлений компании «ЭлектроПласт» является направление «Источники питания». Мы предлагаем Вам помощь Конструкторского отдела:

- Подбор оптимального решения, техническое обоснование при выборе компонента;
- Подбор аналогов;
- Консультации по применению компонента;
- Поставка образцов и прототипов;
- Техническая поддержка проекта;
- Защита от снятия компонента с производства.



#### Как с нами связаться

**Телефон:** 8 (812) 309 58 32 (многоканальный)

**Факс:** 8 (812) 320-02-42

**Электронная почта:** [org@eplast1.ru](mailto:org@eplast1.ru)

**Адрес:** 198099, г. Санкт-Петербург, ул. Калинина, дом 2, корпус 4, литера А.