



# PIC16(L)F1717/8/9

## Cost-Effective 8-Bit Intelligent Analog Flash Microcontrollers

### Description:

PIC16(L)F1717/8/9 microcontrollers combine Intelligent Analog integration with low cost and extreme low power (XLP) to suit a variety of general purpose applications. These 28-pin and 40-pin devices deliver on-chip op amps, Core Independent Peripherals (CLC, NCO and COG), Peripheral Pin Select and Zero-Cross Detect, providing for increased design flexibility.

### Core Features:

- C Compiler Optimized RISC Architecture
- Only 49 Instructions
- Operating Speed:
  - 0-32 MHz clock input
  - 125 ns minimum instruction cycle
- Interrupt Capability
- 16-Level Deep Hardware Stack
- Up to Four 8-Bit Timers
- One 16-Bit Timer
- Power-on Reset (POR)
- Power-up Timer (PWRT)
- Low-Power Brown-out Reset (LPBOR)
- Programmable Watchdog Timer (WDT) up to 256s
- Programmable Code Protection

### Memory:

- Up to 16 Kwords Flash Program Memory
- Up to 2048 Bytes Data SRAM Memory
- Direct, Indirect and Relative Addressing modes
- High-Endurance Flash (HEF):
  - 128B of nonvolatile data storage
  - 100K Erase/Write cycles

### Operating Characteristics:

- Operating Voltage Range:
  - 1.8V to 3.6V (PIC16LF1717/8/9)
  - 2.3V to 5.5V (PIC16F1717/8/9)
- Temperature Range:
  - Industrial: -40°C to 85°C
  - Extended: -40°C to 125°C

### eXtreme Low-Power (XLP) Features:

- Sleep mode: 50 nA @ 1.8V, typical
- Watchdog Timer: 500 nA @ 1.8V, typical
- Secondary Oscillator: 500 nA @ 32 kHz
- Operating Current:
  - 8 uA @ 32 kHz, 1.8V, typical
  - 32 uA/MHz @ 1.8V, typical

### Digital Peripherals:

- Configurable Logic Cell (CLC):
  - Integrated combinational and sequential logic
- Complementary Output Generator (COG):
  - Rising/falling edge dead-band control/blanking
- Numerically Controlled Oscillator (NCO):
  - Generates true linear frequency control and increased frequency resolution
  - Input Clock: 0 Hz < FNCO < 32 MHz
  - Resolution: FNCO/220
- Capture/Compare/PWM (CCP) module
- PWM: Two 10-Bit Pulse-Width Modulators
- Serial Communications:
  - SPI, I<sup>2</sup>C, RS-232, RS-485, LIN compatible
  - Auto-Baud Detect, auto-wake-up on start
- Up to 35 I/O Pins and One Input Pin:
  - Individually programmable pull-ups
  - Slew rate control
  - Interrupt-on-Change with edge-select
- Peripheral Pin Select (PPS):
  - Enables pin mapping of digital I/O

### Intelligent Analog Peripherals:

- Operational Amplifiers:
  - Two configurable rail-to-rail op amps
  - Selectable internal and external channels
  - 2 MHz gain bandwidth product
- High-Speed Comparators:
  - Up to two comparators
  - 50 ns response time
  - Rail-to-rail inputs
- 10-Bit Analog-to-Digital Converter (ADC):
  - Up to 28 external channels
  - Conversion available during Sleep
  - Temperature indicator
- Zero-Cross Detector (ZCD):
  - Detect when AC signal on pin crosses ground
- 8-Bit Digital-to-Analog Converter (DAC):
  - Output available externally
  - Internal connections to comparators, op amps, Fixed Voltage Reference (FVR) and ADC
- Internal Voltage Reference module

# PIC16(L)F1717/8/9

## Clocking Structure:

- 16 MHz Internal Oscillator Block:
  - $\pm 1\%$  at calibration
  - Selectable frequency range from 0 to 32 MHz
- 31 kHz Low-Power Internal Oscillator
- External Oscillator Block with:
  - Three crystal/resonator modes up to 20 MHz
  - Two external clock modes up to 20 MHz
- Fail-Safe Clock Monitor
- Two-Speed Oscillator Start-up
- Oscillator Start-up Timer (OST)

## Programming/Debug Features:

- In-Circuit Debug Integrated On-Chip
- Emulation Header for Advanced Debug:
  - Provides trace, background debug and up to 32 hardware break points
- In-Circuit Serial Programming™ (ICSP™) via Two Pins

## PIC16(L)F171X Family Types

Device	Data Sheet Index	Program Memory Flash (words)	Data SRAM (bytes)	High Endurance Flash (bytes)	I/Os <sup>(2)</sup>	10-bit ADC (ch)	5/8-bit DAC	High-Speed/Comparators	Op Amp	Zero Cross	Timers (8/16-bit)	CCP	PWM	COG	EUSART	MSSP (I <sup>2</sup> C/SPI)	CLC	NCO	PPS	Debug <sup>(1)</sup>	XLP
PIC16(L)F1713	(1)	4096	512	128	25	17	1/1	2	2	1	4/1	2	2	1	1	1	4	1	Y	I/E	Y
PIC16(L)F1716	(1)	8192	1024	128	25	17	1/1	2	2	1	4/1	2	2	1	1	1	4	1	Y	I/E	Y
PIC16(L)F1717	(2)	8192	1024	128	36	28	1/1	2	2	1	4/1	2	2	1	1	1	4	1	Y	I/E	Y
PIC16(L)F1718	(2)	16384	2048	128	25	17	1/1	2	2	1	4/1	2	2	1	1	1	4	1	Y	I/E	Y
PIC16(L)F1719	(2)	16384	2048	128	36	28	1/1	2	2	1	4/1	2	2	1	1	1	4	1	Y	I/E	Y

**Note 1:** Debugging Methods: (I) – Integrated on Chip; (H) – using Debug Header; E – using Emulation Header.

**2:** One pin is input-only.

**Data Sheet Index:** (Unshaded devices are described in this document.)

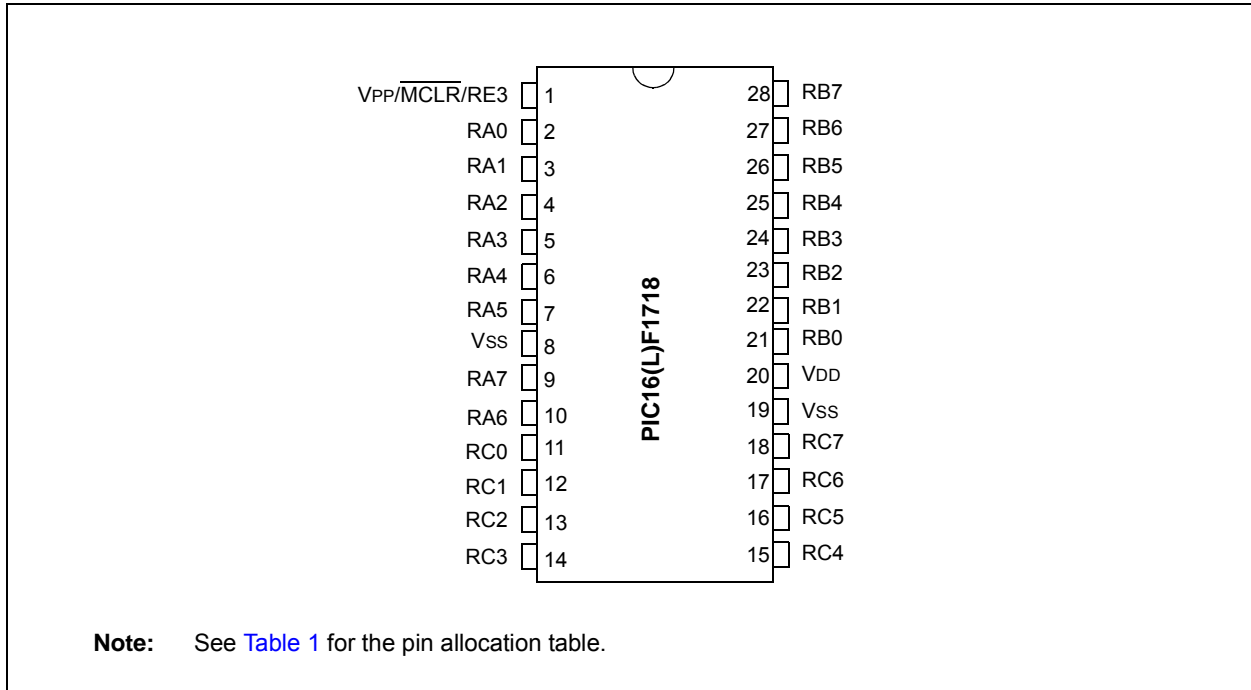
**1:** DS40001726 [PIC16\(L\)F1713/6 Data Sheet, 28-Pin Flash, 8-bit Microcontrollers.](#)

**2:** DS40001740 [PIC16\(L\)F1717/8/9 Data Sheet, 28/40-Pin Flash, 8-bit Microcontrollers.](#)

**Note:** For other small form-factor package availability and marking information, please visit <http://www.microchip.com/packaging> or contact your local sales office.

## Pin Diagrams

**FIGURE 1: 28-PIN SPDIP, SOIC, SSOP**



**FIGURE 2: 28-PIN (U)QFN**

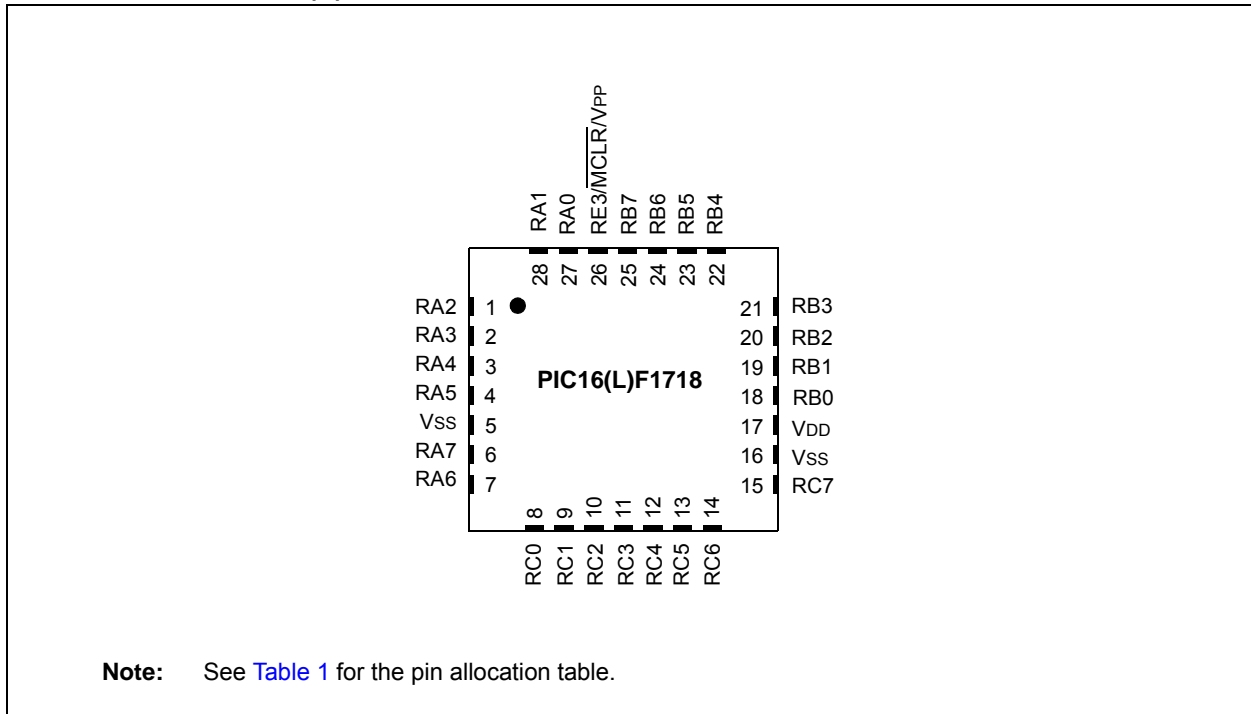


TABLE 1: 28-PIN ALLOCATION TABLE (PIC16(L)F1718)

( <sup>2</sup> )IO/I	SPDIP,SOIC, SSOP	QFN, UQFN	ADC	Reference	Comparator	Op Amp	DAC	Zero Cross	Timers	CCP	NCO	PWM	COG	MSSP	EUSART	CLC	Interrupt	Pull-up	Basic			
RA0	2	27	AN0		C1IN0- C2IN0-											CLCIN0 <sup>(1)</sup>	IOC	Y				
RA1	3	28	AN1		C1IN1- C2IN1-	OPA1OUT										CLCIN1 <sup>(1)</sup>	IOC	Y				
RA2	4	1	AN2	V <sub>REF-</sub>	C1IN0+ C2IN0+		DAC1OUT1												IOC	Y		
RA3	5	2	AN3	V <sub>REF+</sub>	C1IN1+														IOC	Y		
RA4	6	3				OPA1IN+			T0CKI <sup>(1)</sup>										IOC	Y		
RA5	7	4	AN4			OPA1IN-	DAC2OUT1							SS <sup>(1)</sup>					IOC	Y		
RA6	10	7																	IOC	Y	OSC2 CLKOUT	
RA7	9	6																	IOC	Y	OSC1 CLKIN	
RB0	21	18	AN12		C2IN1+			ZCD					COG1IN <sup>(1)</sup>						INT <sup>(1)</sup> IOC	Y		
RB1	22	19	AN10		C1IN3- C2IN3-	OPA2OUT													IOC	Y		
RB2	23	20	AN8			OPA2IN-													IOC	Y		
RB3	24	21	AN9		C1IN2- C2IN2-	OPA2IN+													IOC	Y		
RB4	25	22	AN11																IOC	Y		
RB5	26	23	AN13						T1G <sup>(1)</sup>										IOC	Y		
RB6	27	24																	CLCIN2 <sup>(1)</sup>	IOC	Y	ICSPCLK
RB7	28	25					DAC1OUT2 DAC2OUT2												CLCIN3 <sup>(1)</sup>	IOC	Y	ICSPDAT
RC0	11	8							T1CKI <sup>(1)</sup> SOSCO										IOC	Y		
RC1	12	9							SOSCI	CCP2 <sup>(1)</sup>									IOC	Y		
RC2	13	10	AN14							CCP1 <sup>(1)</sup>									IOC	Y		
RC3	14	11	AN15											SCL/SCK <sup>(1)</sup>					IOC	Y		

Note 1: Default peripheral input. Alternate pins can be selected as the peripheral input with the PPS input selection registers.

2: All pin digital outputs default to PORT latch data. Alternate outputs can be selected as the peripheral digital output with the PPS output selection registers.

3: These peripheral functions are bidirectional. The output pin selections must be the same as the input pin selections.

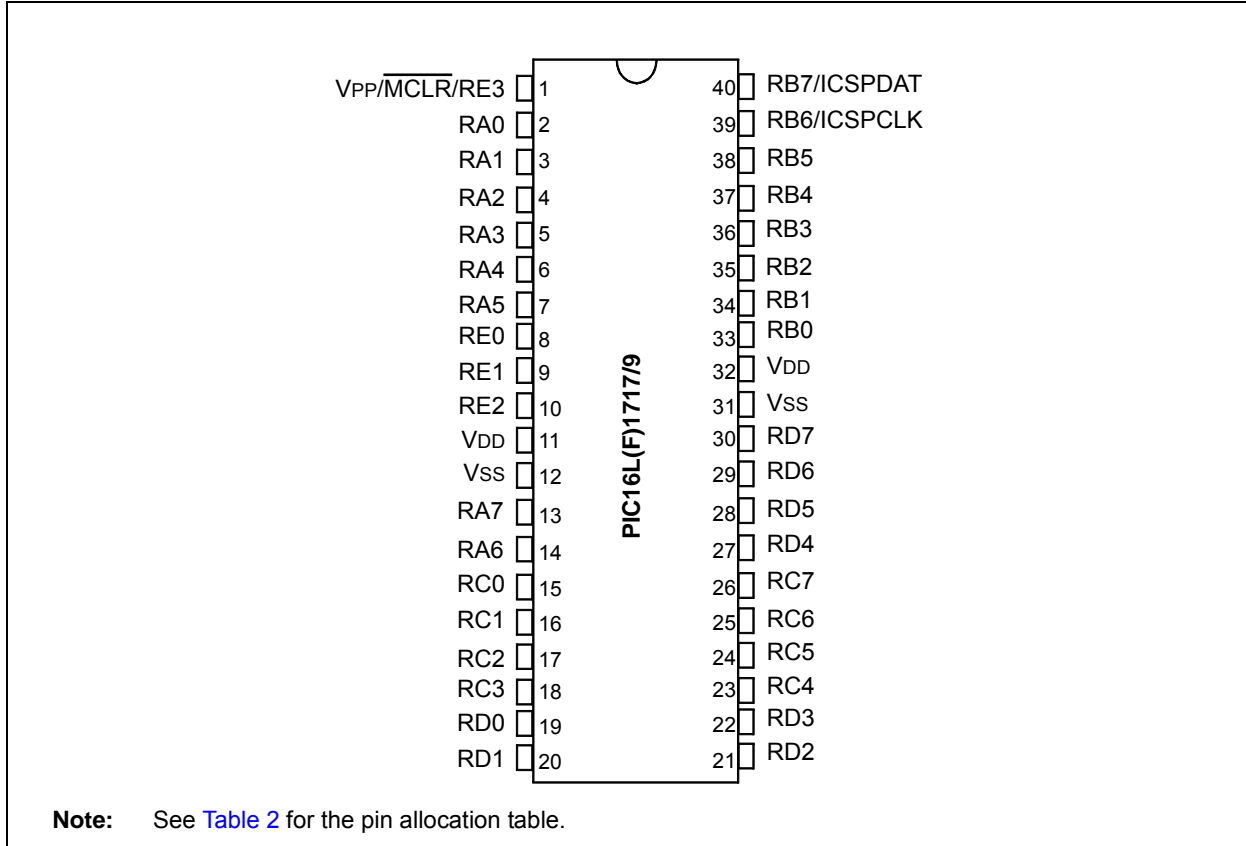
4: Alternate outputs are excluded from solid shaded areas.

5: Alternate inputs are excluded from dot shaded areas.

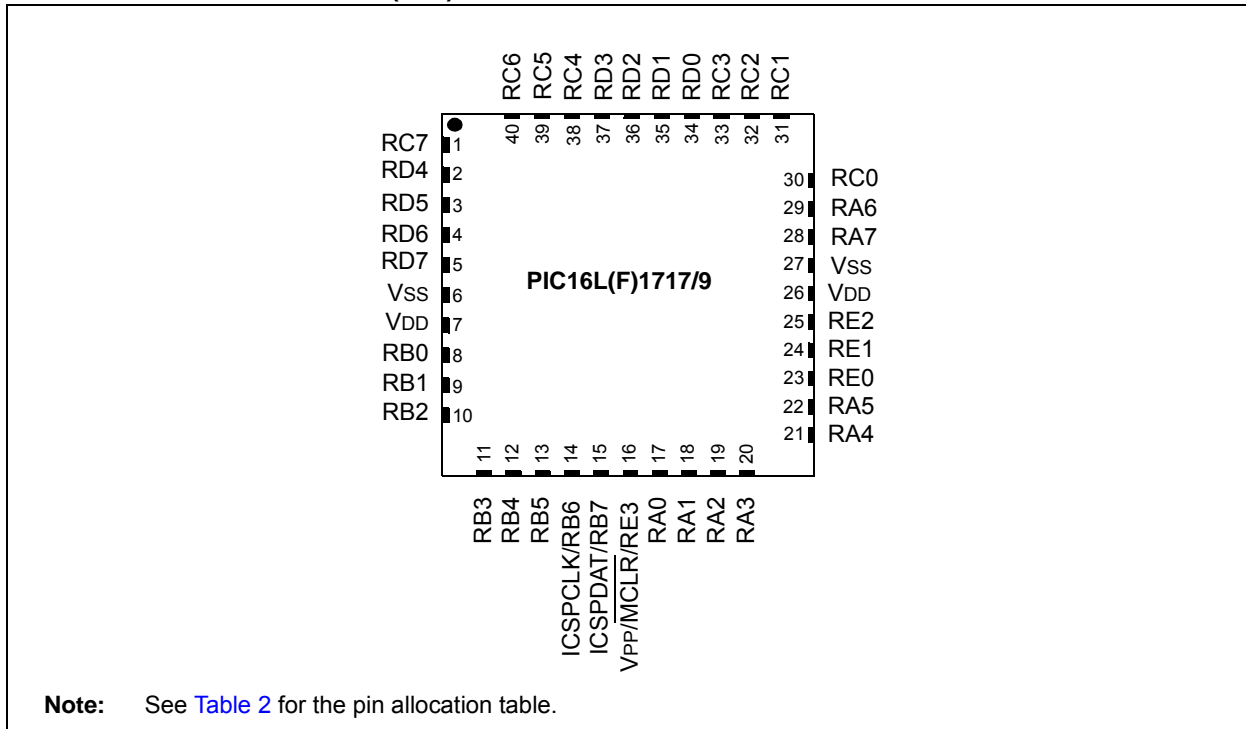


# PIC16(L)F1717/8/9

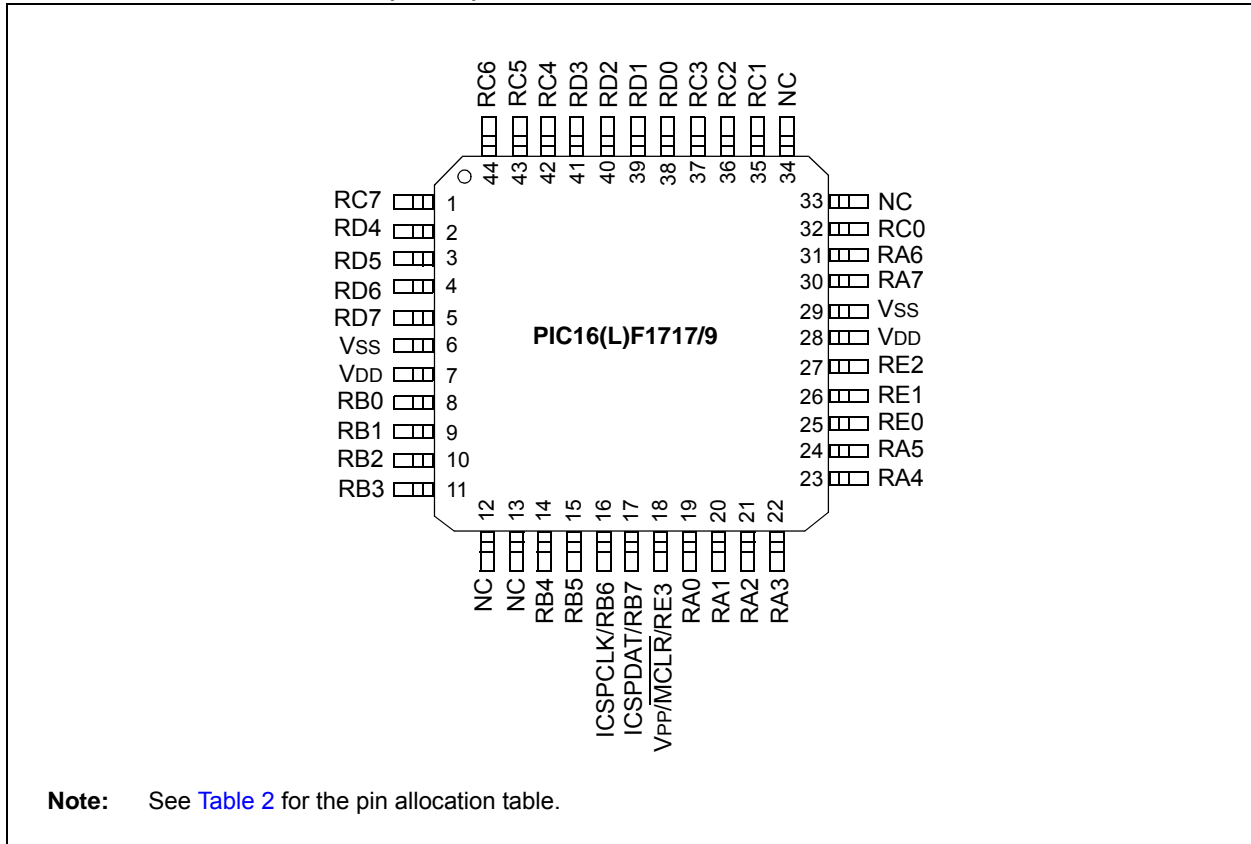
**FIGURE 3: 40-PIN PDIP**



**FIGURE 4: 40-PIN UQFN (5X5)**



**FIGURE 5: 44-PIN TQFP (10X10)**



**TABLE 2: 40/44-PIN ALLOCATION TABLE (PIC16(L)F1717/9)**

I/O <sup>(2)</sup>	PDIP	TQFP	UQFN	ADC	Reference	Comparator	Op Amp	DAC	Zero Cross	Timers	CCP	NCO	PWM	COG	MSSP	EUSART	CLC	Interrupt	Pullup	Basic		
RA0	2	19	17	AN0		C1IN0- C2IN0-											CLCIN0 <sup>(1)</sup>	IOC	Y			
RA1	3	20	18	AN1		C1IN1- C2IN1-	OPA1OUT										CLCIN1 <sup>(1)</sup>	IOC	Y			
RA2	4	21	19	AN2	V <sub>REF-</sub>	C1IN0+ C2IN0+		DAC1OUT1														
RA3	5	22	20	AN3	V <sub>REF+</sub>	C1IN1+																
RA4	6	23	21				OPA1IN+			T0CKI <sup>(1)</sup>												
RA5	7	24	22	AN4			OPA1IN-	DAC2OUT1							nSS <sup>(1)</sup>							
RA6	14	31	29																	OSC2 CLKOUT		
RA7	13	30	28																		OSC1 CLKIN	
RB0	33	8	8	AN12		C2IN1+			ZCD					COG1IN <sup>(1)</sup>						INT <sup>(1)</sup> IOC	Y	
RB1	34	9	9	AN10		C1IN3- C2IN3-	OPA2OUT															
RB2	35	10	10	AN8			OPA2IN-															
RB3	36	11	11	AN9		C1IN2- C2IN2-	OPA2IN+															
RB4	37	14	12	AN11																		
RB5	38	15	13	AN13						T1G <sup>(1)</sup>												
RB6	39	16	14																			
RB7	40	17	15					DAC1OUT2 DAC2OUT2														
RC0	15	32	30							T1CKI <sup>(1)</sup> SOSCI												
RC1	16	35	31								CCP2 <sup>(1)</sup>											
RC2	17	36	32	AN14							CCP1 <sup>(1)</sup>											
RC3	18	37	33	AN15											SCL/SCK <sup>(1)</sup>							

- Note 1: Default peripheral input. Alternate pins can be selected as the peripheral input with the PPS input selection registers.
- 2: All pin digital outputs default to PORT latch data. Alternate outputs can be selected as the peripheral digital output with the PPS output selection registers.
- 3: These peripheral functions are bidirectional. The output pin selections must be the same as the input pin selections.
- 4: Alternate outputs are excluded from solid shaded areas.
- 5: Alternate inputs are excluded from dot shaded areas.



**TABLE 2: 40/44-PIN ALLOCATION TABLE (PIC16(L)F1717/9) (CONTINUED)**

I/O <sup>(2)</sup>	PDIP	TQFP	UQFN	ADC	Reference	Comparator	Op Amp	DAC	Zero Cross	Timers	CCP	NCO	PWM	COG	MSSP	EUSART	CLC	Interrupt	Pullup	Basic					
RC4	23	42	38	AN16											SDI <sup>(1)</sup> SDA <sup>(1)</sup>					IOC	Y				
RC5	24	43	39	AN17																	IOC	Y			
RC6	25	44	40	AN18																	IOC	Y			
RC7	26	1	1	AN19												CK <sup>(3)</sup> RX <sup>(3)</sup>					IOC	Y			
RD0	19	38	34	AN20																		Y			
RD1	20	39	35	AN21																		Y			
RD2	21	40	36	AN22																		Y			
RD3	22	41	37	AN23																		Y			
RD4	27	2	2	AN24																		Y			
RD5	28	3	3	AN25																		Y			
RD6	29	4	4	AN26																		Y			
RD7	30	5	5	AN27																		Y			
RE0	8	25	23	AN5																		Y			
RE1	9	26	24	AN6																		Y			
RE2	10	27	25	AN7																		Y			
RE3	1	18	16																			IOC	Y	MCLR V <sub>PP</sub>	
V <sub>DD</sub>	11	7	7																					V <sub>DD</sub>	
	32	28	26																						
V <sub>SS</sub>	12	6	6																						V <sub>SS</sub>
	31	29	27																						
OUT <sup>(4)</sup>						C1OUT C2OUT					CCP1 CCP2	NCO1OUT	PWM3OUT PWM4OUT	COG1A COG1B COG1C COG1D	SDA <sup>(3)</sup> SCK/SCL <sup>(3)</sup>	SDO TXCK DT <sup>(3)</sup>	CLC4OUT CLC3OUT CLC2OUT CLC1OUT								
IN <sup>(5)</sup>										T1G T1CKI T0CKI	CCP1 CCP2			COG1IN	SDI SCK/SCL <sup>(3)</sup>	SS RX <sup>(3)</sup> CK	CLCIN0 CLCIN1 CLCIN2 CLCIN3	INT							

Note 1: Default peripheral input. Alternate pins can be selected as the peripheral input with the PPS input selection registers.  
 2: All pin digital outputs default to PORT latch data. Alternate outputs can be selected as the peripheral digital output with the PPS output selection registers.  
 3: These peripheral functions are bidirectional. The output pin selections must be the same as the input pin selections.  
 4: Alternate outputs are excluded from solid shaded areas.  
 5: Alternate inputs are excluded from dot shaded areas.

# PIC16(L)F1717/8/9

---

## Table of Contents

1.0	Device Overview .....	12
2.0	Enhanced Mid-Range CPU .....	22
3.0	Memory Organization .....	24
4.0	Device Configuration .....	55
5.0	Resets .....	60
6.0	Oscillator Module (with Fail-Safe Clock Monitor) .....	68
7.0	Interrupts .....	86
8.0	Power-Down Mode (Sleep) .....	98
9.0	Watchdog Timer (WDT) .....	102
10.0	Flash Program Memory Control .....	106
11.0	I/O Ports .....	122
12.0	Peripheral Pin Select (PPS) Module .....	150
13.0	Interrupt-On-Change .....	156
14.0	Fixed Voltage Reference (FVR) .....	163
15.0	Temperature Indicator Module .....	166
16.0	Comparator Module .....	168
17.0	Pulse Width Modulation (PWM) .....	177
18.0	Complementary Output Generator (COG) Module .....	184
19.0	Configurable Logic Cell (CLC) .....	218
20.0	Numerically Controlled Oscillator (NCO) Module .....	233
21.0	Analog-to-Digital Converter (ADC) Module .....	242
22.0	Operational Amplifier (OPA) Modules .....	255
23.0	8-Bit Digital-to-Analog Converter (DAC1) Module .....	258
24.0	5-Bit Digital-to-Analog Converter (DAC2) Module .....	261
25.0	Zero-Cross Detection (ZCD) Module .....	264
26.0	Timer0 Module .....	268
27.0	Timer1 Module with Gate Control .....	271
28.0	Timer2/4/6 Module .....	282
29.0	Capture/Compare/PWM Modules .....	287
30.0	Master Synchronous Serial Port (MSSP) Module .....	295
31.0	Enhanced Universal Synchronous Asynchronous Receiver Transmitter (EUSART) .....	351
32.0	In-Circuit Serial Programming (ICSP™) .....	381
33.0	Instruction Set Summary .....	383
34.0	Electrical Specifications .....	397
35.0	DC and AC Characteristics Graphs and Charts .....	432
36.0	Development Support .....	454
37.0	Packaging Information .....	458
	Appendix A: Data Sheet Revision History .....	479

## TO OUR VALUED CUSTOMERS

It is our intention to provide our valued customers with the best documentation possible to ensure successful use of your Microchip products. To this end, we will continue to improve our publications to better suit your needs. Our publications will be refined and enhanced as new volumes and updates are introduced.

If you have any questions or comments regarding this publication, please contact the Marketing Communications Department via E-mail at [docerrors@microchip.com](mailto:docerrors@microchip.com). We welcome your feedback.

### Most Current Data Sheet

To obtain the most up-to-date version of this data sheet, please register at our Worldwide Website at:

<http://www.microchip.com>

You can determine the version of a data sheet by examining its literature number found on the bottom outside corner of any page. The last character of the literature number is the version number, (e.g., DS30000000A is version A of document DS30000000).

### Errata

An errata sheet, describing minor operational differences from the data sheet and recommended workarounds, may exist for current devices. As device/documentation issues become known to us, we will publish an errata sheet. The errata will specify the revision of silicon and revision of document to which it applies.

To determine if an errata sheet exists for a particular device, please check with one of the following:

- Microchip's Worldwide Website; <http://www.microchip.com>
- Your local Microchip sales office (see last page)

When contacting a sales office, please specify which device, revision of silicon and data sheet (include literature number) you are using.

### Customer Notification System

Register on our website at [www.microchip.com](http://www.microchip.com) to receive the most current information on all of our products.

# PIC16(L)F1717/8/9

## 1.0 DEVICE OVERVIEW

The PIC16(L)F1717/8/9 devices are described within this data sheet. They are available in the following package configurations:

- 28-pin SPDIP, SSOP, SOIC, QFN and UQFN
- 40-pin PDIP and UQFN
- 44-pin TQFP

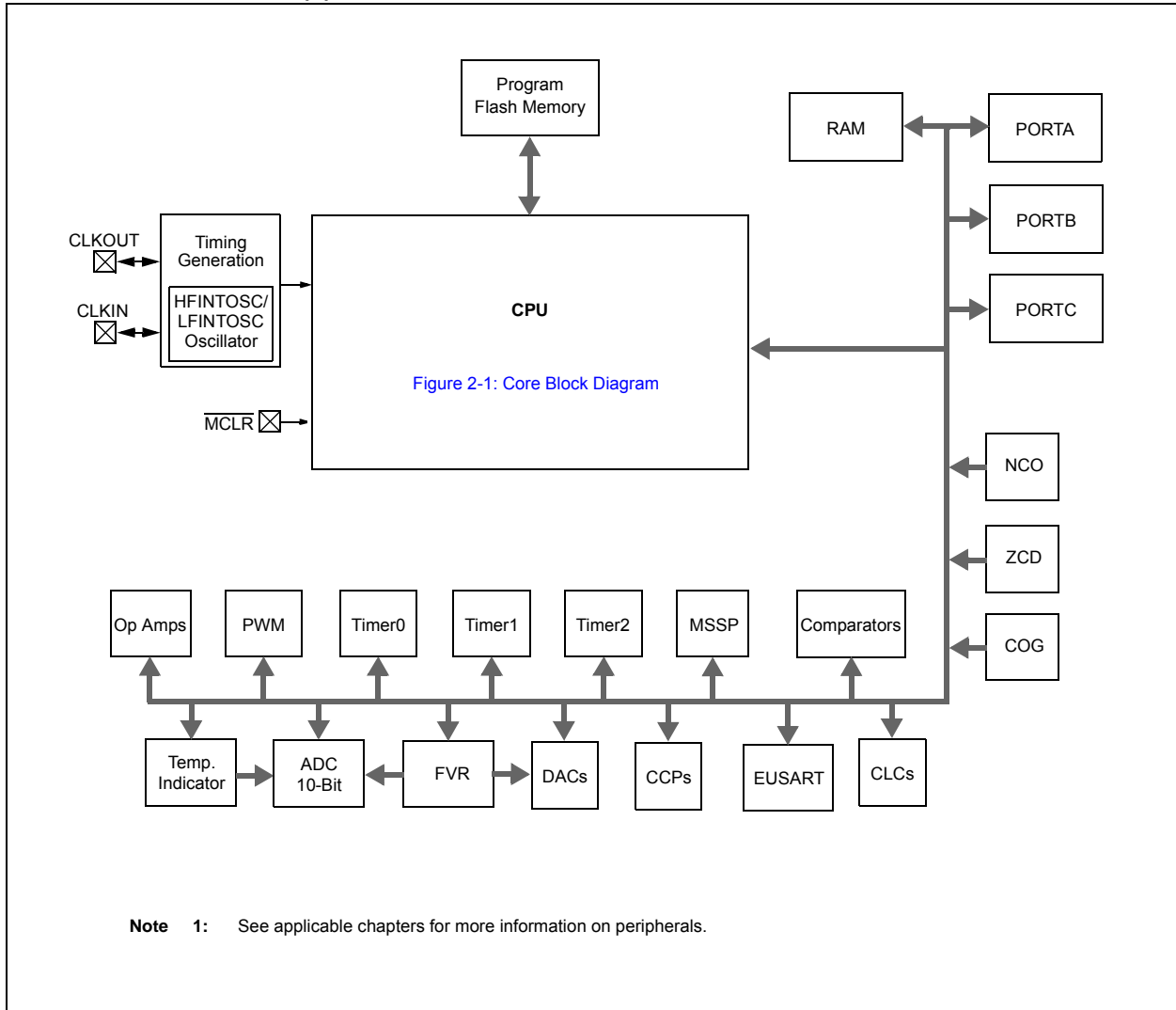
Figure 1-1 and Figure 1-2 show block diagrams of the PIC16(L)F1717/8/9 devices. Table 1-2 shows the pinout descriptions.

Reference Table 1-1 for peripherals available per device.

**TABLE 1-1: DEVICE PERIPHERAL SUMMARY**

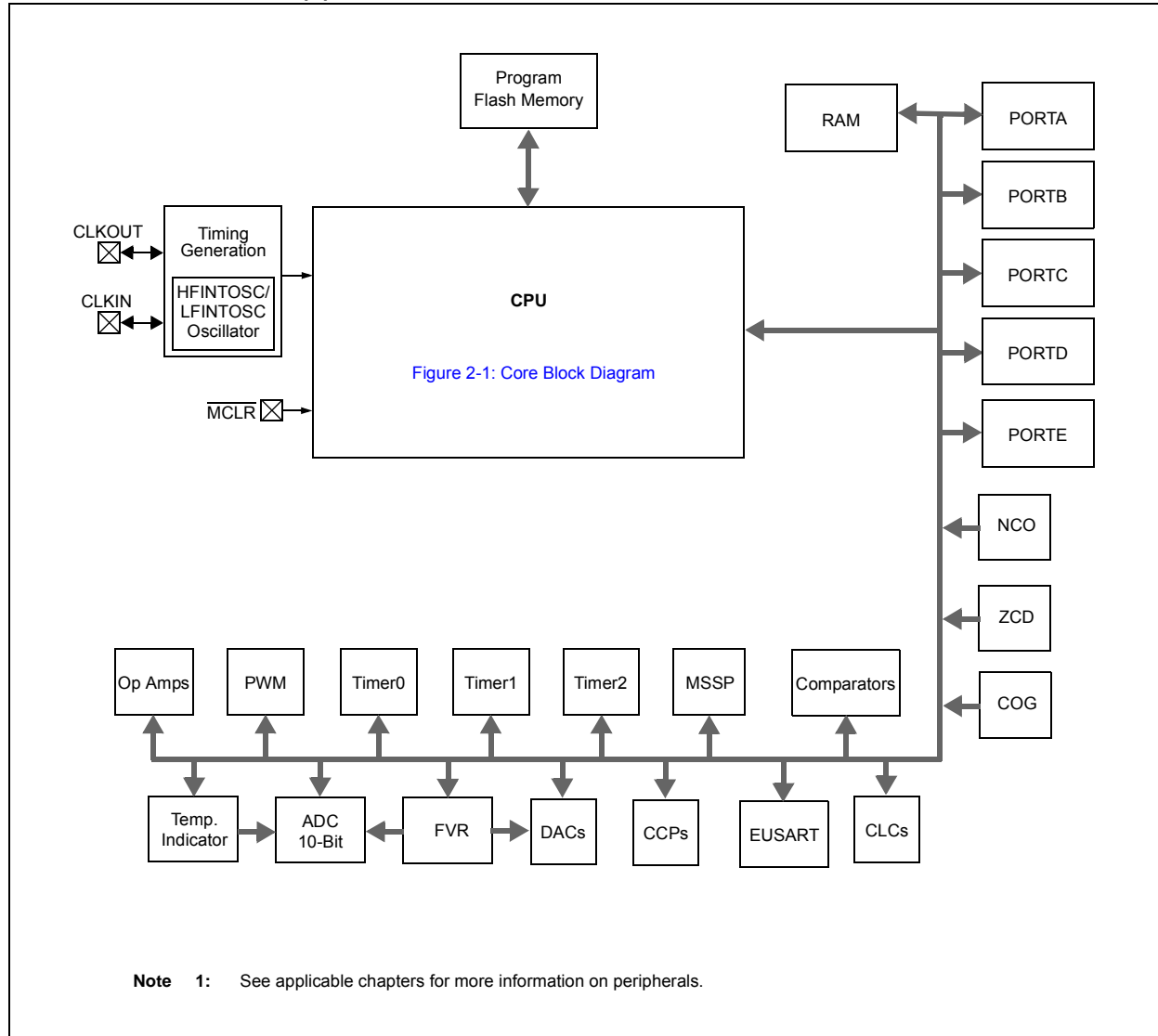
Peripheral	PIC16(L)F1717	PIC16(L)F1718	PIC16(L)F1719
Analog-to-Digital Converter (ADC)	•	•	•
Fixed Voltage Reference (FVR)	•	•	•
Zero-Cross Detection (ZCD)	•	•	•
Temperature Indicator	•	•	•
Complementary Output Generator (COG)			
COG	•	•	•
Numerically Controlled Oscillator (NCO)			
NCO	•	•	•
Digital-to-Analog Converter (DAC)			
DAC1	•	•	•
DAC2	•	•	•
Capture/Compare/PWM (CCP/ECCP) Modules			
CCP1	•	•	•
CCP2	•	•	•
Comparators			
C1	•	•	•
C2	•	•	•
Configurable Logic Cell (CLC)			
CLC1	•	•	•
CLC2	•	•	•
CLC3	•	•	•
CLC4	•	•	•
Enhanced Universal Synchronous/Asynchronous Receiver/Transmitter (EUSART)			
EUSART	•	•	•
Master Synchronous Serial Ports			
MSSP	•	•	•
Op Amp			
Op Amp 1	•	•	•
Op Amp 2	•	•	•
Pulse-Width Modulator (PWM)			
PWM3	•	•	•
PWM4	•	•	•
Timers			
Timer0	•	•	•
Timer1	•	•	•
Timer2	•	•	•

**FIGURE 1-1: PIC16(L)F1718 BLOCK DIAGRAM**



# PIC16(L)F1717/8/9

FIGURE 1-2: PIC16(L)F1717/9 BLOCK DIAGRAM



**TABLE 1-2: PIC16(L)F1718 PINOUT DESCRIPTION**

Name	Function	Input Type	Output Type	Description
RA0/AN0/C1IN0-/C2IN0-/CLCIN0 <sup>(1)</sup>	RA0	TTL/ST	CMOS	General purpose I/O.
	AN0	AN	—	ADC Channel 0 input.
	C1IN0-	AN	—	Comparator C2 negative input.
	C2IN0-	AN	—	Comparator C3 negative input.
	CLCIN0	TTL/ST	—	Configurable Logic Cell source input.
RA1/AN1/C1IN1-/C2IN1-/OPA1OUT/CLCIN1 <sup>(1)</sup>	RA1	TTL/ST	CMOS	General purpose I/O.
	AN1	AN	—	ADC Channel 1 input.
	C1IN1-	AN	—	Comparator C1 negative input.
	C2IN1-	AN	—	Comparator C2 negative input.
	OPA1OUT	—	AN	Operational Amplifier 1 output.
	CLCIN1	TTL/ST	—	Configurable Logic Cell source input.
RA2/AN2/VREF-/C1IN0+/C2IN0+/DAC1OUT1	RA2	TTL/ST	CMOS	General purpose I/O.
	AN2	AN	—	ADC Channel 2 input.
	VREF-	AN	—	ADC Negative Voltage Reference input.
	C1IN0+	AN	—	Comparator C2 positive input.
	C2IN0+	AN	—	Comparator C3 positive input.
	DAC1OUT1	—	AN	Digital-to-Analog Converter output.
RA3/AN3/VREF+/C1IN1+	RA3	TTL/ST	CMOS	General purpose I/O.
	AN3	AN	—	ADC Channel 3 input.
	VREF+	AN	—	ADC Voltage Reference input.
	C1IN1+	AN	—	Comparator C1 positive input.
RA4/OPA1IN+/T0CKI <sup>(1)</sup>	RA4	TTL/ST	CMOS	General purpose I/O.
	OPA1IN+	AN	—	Operational Amplifier 1 non-inverting input.
	T0CKI	TTL/ST	—	Timer0 gate input.
RA5/AN4/OPA1IN-/DAC2OUT1/SS <sup>(1)</sup>	RA5	TTL/ST	CMOS	General purpose I/O.
	AN4	AN	—	ADC Channel 4 input.
	OPA1IN-	AN	—	Operational Amplifier 1 inverting input.
	DAC2OUT1	—	AN	Digital-to-Analog Converter output.
RA6/OSC2/CLKOUT	RA6	TTL/ST	CMOS	General purpose I/O.
	OSC2	—	XTAL	Crystal/Resonator (LP, XT, HS modes).
	CLKOUT	—	CMOS	Fosc/4 output.
RA7/OSC1/CLKIN	RA7	TTL/ST	CMOS	General purpose I/O.
	OSC1	—	XTAL	Crystal/Resonator (LP, XT, HS modes).
	CLKIN	ST	—	External clock input (EC mode).
RB0/AN12/C2IN1+/ZCD/COGIN <sup>(1)</sup>	RB0	TTL/ST	CMOS	General purpose I/O.
	AN12	AN	—	ADC Channel 12 input.
	C2IN1+	AN	—	Comparator C2 positive input.
	ZCD	AN	—	Zero-Cross Detection Current Source/Sink.
	COGIN	TTL/ST	CMOS	Complementary Output Generator input.

**Legend:** AN = Analog input or output    CMOS = CMOS compatible input or output    OD = Open-Drain  
TTL = TTL compatible input    ST = Schmitt Trigger input with CMOS levels    I<sup>2</sup>C = Schmitt Trigger input with I<sup>2</sup>C  
HV = High Voltage    XTAL = Crystal levels

- Note**
- 1: Default peripheral input. Alternate pins can be selected as the peripheral input with the PPS input selection registers.
  - 2: All pin digital outputs default to PORT latch data. Alternate outputs can be selected as the peripheral digital output with the PPS output selection registers.
  - 3: These peripheral functions are bidirectional. The output pin selections must be the same as the input pin selections.

# PIC16(L)F1717/8/9

**TABLE 1-2: PIC16(L)F1718 PINOUT DESCRIPTION (CONTINUED)**

Name	Function	Input Type	Output Type	Description
RB1/AN10/C1IN3-/C2IN3-/OPA2OUT	RB1	TTL/ST	CMOS	General purpose I/O.
	AN10	AN	—	ADC Channel 10 input.
	C1IN3-	AN	—	Comparator C1 negative input.
	C2IN3-	AN	—	Comparator C2 negative input.
	OPA2OUT	—	AN	Operational Amplifier 2 output.
RB2/AN8/OPA2IN-	RB2	TTL/ST	CMOS	General purpose I/O.
	AN8	AN	—	ADC Channel 8 input.
	OPA2IN-	AN	—	Operational Amplifier 2 inverting input.
RB3/AN9/C1IN2-/C2IN2-/OPA2IN+	RB3	TTL/ST	CMOS	General purpose I/O.
	AN9	AN	—	ADC Channel 9 input.
	C1IN2-	AN	—	Comparator C1 negative input.
	C2IN2-	AN	—	Comparator C2 negative input.
	OPA2IN+	AN	—	Operational Amplifier 2 non-inverting input.
RB4/AN11	RB4	TTL/ST	CMOS	General purpose I/O.
	AN11	AN	—	ADC Channel 11 input.
RB5/AN13/T1G <sup>(1)</sup>	RB5	TTL/ST	CMOS	General purpose I/O.
	AN13	AN	—	ADC Channel 13 input.
	T1G	TTL/ST	—	Timer1 gate input.
RB6/CLCIN2 <sup>(1)</sup> /ICSPCLK	RB6	TTL/ST	CMOS	General purpose I/O.
	CLCIN2	TTL/ST	—	Configurable Logic Cell source input.
	ICSPCLK	ST	—	Serial Programming Clock.
RB7/DAC1OUT2/DAC2OUT2/CLCIN3 <sup>(1)</sup> /ICSPDAT	RB7	TTL/ST	CMOS	General purpose I/O.
	DAC1OUT2	—	AN	Digital-to-Analog Converter output.
	DAC2OUT2	—	AN	Digital-to-Analog Converter output.
	CLCIN3	TTL/ST	—	Configurable Logic Cell source input.
	ICSPDAT	ST	CMOS	ICSP™ Data I/O.
RC0/T1CKI <sup>(1)</sup> /SOSCO	RC0	TTL/ST	CMOS	General purpose I/O.
	T1CKI	TTL/ST	—	Timer1 clock input.
	SOSCO	XTAL	XTAL	Secondary Oscillator Connection.
RC1/SOSCI/CCP2 <sup>(1)</sup>	RC1	TTL/ST	CMOS	General purpose I/O.
	SOSCI	XTAL	XTAL	Secondary Oscillator Connection.
	CCP2	TTL/ST	—	Capture input
RC2/AN14/CCP1 <sup>(1)</sup>	RC2	TTL/ST	CMOS	General purpose I/O.
	AN14	AN	—	ADC Channel 14 input.
	CCP1	TTL/ST	—	Capture input
RC3/AN15/SCK <sup>(1)</sup> /SCL <sup>(1)</sup>	RC3	TTL/ST	CMOS	General purpose I/O.
	AN15	AN	—	ADC Channel 15 input.
	SCK	TTL/ST	—	SPI clock input
	SCL	I <sup>2</sup> C	—	I <sup>2</sup> C clock input.

**Legend:** AN = Analog input or output    CMOS = CMOS compatible input or output    OD = Open-Drain  
TTL = TTL compatible input    ST = Schmitt Trigger input with CMOS levels    I<sup>2</sup>C = Schmitt Trigger input with I<sup>2</sup>C  
HV = High Voltage    XTAL = Crystal levels

- Note** 1: Default peripheral input. Alternate pins can be selected as the peripheral input with the PPS input selection registers.  
2: All pin digital outputs default to PORT latch data. Alternate outputs can be selected as the peripheral digital output with the PPS output selection registers.  
3: These peripheral functions are bidirectional. The output pin selections must be the same as the input pin selections.



**TABLE 1-2: PIC16(L)F1718 PINOUT DESCRIPTION (CONTINUED)**

Name	Function	Input Type	Output Type	Description
RC4/AN16/SDI <sup>(1)</sup> /SDA <sup>(1)</sup>	RC4	TTL/ST	CMOS	General purpose I/O.
	AN16	AN	—	ADC Channel 16 input.
	SDI	TTL/ST	—	SPI Data input.
	SDA	I <sup>2</sup> C	—	I <sup>2</sup> C Data input.
RC5/AN17	RC5	TTL/ST	CMOS	General purpose I/O.
	AN17	AN	—	ADC Channel 17 input.
RC6/AN18/CK <sup>(1)</sup>	RC6	TTL/ST	CMOS	General purpose I/O.
	AN18	AN	—	ADC Channel 18 input.
	CK	TTL/ST		EUSART synchronous clock.
RC7/AN19/RX <sup>(1)</sup>	RC7	TTL/ST	CMOS	General purpose I/O.
	AN19	AN	—	ADC Channel 19 input.
	RX	TTL/ST	—	EUSART receive.
RE3/MCLR/VPP	RE3	TTL/ST	—	General purpose input.
	MCLR	ST	—	Master clear input.
	VPP	HV	—	Programming enable.
VDD	VDD	Power	—	Positive supply.
VSS	VSS	Power	—	Ground reference.
OUT <sup>(2)</sup>	C1OUT		CMOS	Comparator 1 output.
	C2OUT		CMOS	Comparator 2 output.
	CCP1		CMOS	Compare/PWM1 output.
	CCP2		CMOS	Compare/PWM2 output.
	NCO1OUT		CMOS	Numerically controlled oscillator output.
	PWM3OUT		CMOS	PWM3 output.
	PWM4OUT		CMOS	PWM4 output.
	COG1A		CMOS	Complementary output generator output A.
	COG1B		CMOS	Complementary output generator output B.
	COG1C		CMOS	Complementary output generator output C.
	COG1D		CMOS	Complementary output generator output D.
	SDA <sup>(3)</sup>		OD	I <sup>2</sup> C Data output.
	SCK		CMOS	SPI clock output.
	SCL <sup>(3)</sup>		OD	I <sup>2</sup> C clock output.
	SDO		CMOS	SPI data output.
	TX/CK		CMOS	EUSART asynchronous TX data/synchronous clock out.
	DT <sup>(3)</sup>		CMOS	EUSART synchronous data output.
	CLC1OUT		CMOS	Configurable Logic Cell 1 output.
	CLC2OUT		CMOS	Configurable Logic Cell 2 output.
	CLC3OUT		CMOS	Configurable Logic Cell 3 output.
CLC4OUT		CMOS	Configurable Logic Cell 4 output.	

**Legend:** AN = Analog input or output    CMOS = CMOS compatible input or output    OD = Open-Drain  
TTL = TTL compatible input    ST = Schmitt Trigger input with CMOS levels    I<sup>2</sup>C = Schmitt Trigger input with I<sup>2</sup>C  
HV = High Voltage    XTAL = Crystal levels

- Note** 1: Default peripheral input. Alternate pins can be selected as the peripheral input with the PPS input selection registers.  
2: All pin digital outputs default to PORT latch data. Alternate outputs can be selected as the peripheral digital output with the PPS output selection registers.  
3: These peripheral functions are bidirectional. The output pin selections must be the same as the input pin selections.

# PIC16(L)F1717/8/9

**TABLE 1-3: PIC16(L)F1717/9 PINOUT DESCRIPTION**

Name	Function	Input Type	Output Type	Description
RA0/AN0/C1IN0-/C2IN0-/CLCIN0 <sup>(1)</sup>	RA0	TTL/ST	CMOS	General purpose I/O.
	AN0	AN	—	ADC Channel 0 input.
	C1IN0-	AN	—	Comparator C2 negative input.
	C2IN0-	AN	—	Comparator C3 negative input.
RA1/AN1/C1IN1-/C2IN1-/OPA1OUT/CLCIN1 <sup>(1)</sup>	RA1	TTL/ST	CMOS	General purpose I/O.
	AN1	AN	—	ADC Channel 1 input.
	C1IN1-	AN	—	Comparator C1 negative input.
	C2IN1-	AN	—	Comparator C2 negative input.
	OPA1OUT	—	AN	Operational Amplifier 1 output.
RA2/AN2/VREF-/C1IN0+/C2IN0+/DAC1OUT1	RA2	TTL/ST	CMOS	General purpose I/O.
	AN2	AN	—	ADC Channel 2 input.
	VREF-	AN	—	ADC Negative Voltage Reference input.
	C1IN0+	AN	—	Comparator C2 positive input.
	C2IN0+	AN	—	Comparator C3 positive input.
	DAC1OUT1	—	AN	Digital-to-Analog Converter output.
RA3/AN3/VREF+/C1IN1+	RA3	TTL/ST	CMOS	General purpose I/O.
	AN3	AN	—	ADC Channel 3 input.
	VREF+	AN	—	ADC Voltage Reference input.
	C1IN1+	AN	—	Comparator C1 positive input.
RA4/OPA1IN+/T0CKI <sup>(1)</sup>	RA4	TTL/ST	CMOS	General purpose I/O.
	OPA1IN+	AN	—	Operational Amplifier 1 non-inverting input.
	T0CKI	TTL/ST	—	Timer0 gate input.
RA5/AN4/OPA1IN-/DAC2OUT1/SS <sup>(1)</sup>	RA5	TTL/ST	CMOS	General purpose I/O.
	AN4	AN	—	ADC Channel 4 input.
	OPA1IN-	AN	—	Operational Amplifier 1 inverting input.
	DAC2OUT1	—	AN	Digital-to-Analog Converter output.
RA6/OSC2/CLKOUT	RA6	TTL/ST	CMOS	General purpose I/O.
	OSC2	—	XTAL	Crystal/Resonator (LP, XT, HS modes).
	CLKOUT	—	CMOS	Fosc/4 output.
RA7/OSC1/CLKIN	RA7	TTL/ST	CMOS	General purpose I/O.
	OSC1	—	XTAL	Crystal/Resonator (LP, XT, HS modes).
	CLKIN	ST	—	External clock input (EC mode).
RB0/AN12/C2IN1+/ZCD/COGIN <sup>(1)</sup>	RB0	TTL/ST	CMOS	General purpose I/O.
	AN12	AN	—	ADC Channel 12 input.
	C2IN1+	AN	—	Comparator C2 positive input.
	ZCD	AN	—	Zero-Cross Detection Current Source/Sink.
	COGIN	TTL/ST	—	Complementary Output Generator input.

**Legend:** AN = Analog input or output    CMOS = CMOS compatible input or output    OD = Open-Drain  
TTL = TTL compatible input    ST = Schmitt Trigger input with CMOS levels    I<sup>2</sup>C = Schmitt Trigger input with I<sup>2</sup>C  
HV = High Voltage    XTAL = Crystal levels

- Note**
- 1: Default peripheral input. Alternate pins can be selected as the peripheral input with the PPS input selection registers.
  - 2: All pin digital outputs default to PORT latch data. Alternate outputs can be selected as the peripheral digital output with the PPS output selection registers.
  - 3: These peripheral functions are bidirectional. The output pin selections must be the same as the input pin selections.

**TABLE 1-3: PIC16(L)F1717/9 PINOUT DESCRIPTION (CONTINUED)**

Name	Function	Input Type	Output Type	Description
RB1/AN10/C1IN3-/C2IN3-/OPA2OUT	RB1	TTL/ST	CMOS	General purpose I/O.
	AN10	AN	—	ADC Channel 10 input.
	C1IN3-	AN	—	Comparator C1 negative input.
	C2IN3-	AN	—	Comparator C2 negative input.
	OPA2OUT	—	AN	Operational Amplifier 2 output.
RB2/AN8/OPA2IN-	RB2	TTL/ST	CMOS	General purpose I/O.
	AN8	AN	—	ADC Channel 8 input.
	OPA2IN-	AN	—	Operational Amplifier 2 inverting input.
RB3/AN9/C1IN2-/C2IN2-/OPA2IN+	RB3	TTL/ST	CMOS	General purpose I/O.
	AN9	AN	—	ADC Channel 9 input.
	C1IN2-	AN	—	Comparator C1 negative input.
	C2IN2-	AN	—	Comparator C2 negative input.
	OPA2IN+	AN	—	Operational Amplifier 2 non-inverting input.
RB4/AN11	RB4	TTL/ST	CMOS	General purpose I/O.
	AN11	AN	—	ADC Channel 11 input.
RB5/AN13/T1G <sup>(1)</sup>	RB5	TTL/ST	CMOS	General purpose I/O.
	AN13	AN	—	ADC Channel 13 input.
	T1G	TTL/ST	—	Timer1 gate input.
RB6/CLCIN2 <sup>(1)</sup> /ICSPCLK	RB6	TTL/ST	CMOS	General purpose I/O.
	CLCIN2	TTL/ST	—	Configurable Logic Cell source input.
	ICSPCLK	ST	—	Serial Programming Clock.
RB7/DAC1OUT2/DAC2OUT2/CLCIN3 <sup>(1)</sup> /ICSPDAT	RB7	TTL/ST	CMOS	General purpose I/O.
	DAC1OUT2	—	AN	Digital-to-Analog Converter output.
	DAC2OUT2	—	AN	Digital-to-Analog Converter output.
	CLCIN3	TTL/ST	—	Configurable Logic Cell source input.
	ICSPDAT	ST	CMOS	ICSP™ Data I/O.
RC0/T1CKI <sup>(1)</sup> /SOSCO	RC0	TTL/ST	CMOS	General purpose I/O.
	T1CKI	ST	—	Timer1 clock input.
	SOSCO	XTAL	XTAL	Secondary Oscillator Connection.
RC1/SOSCI/CCP2 <sup>(1)</sup>	RC1	TTL/ST	CMOS	General purpose I/O.
	SOSCI	XTAL	XTAL	Secondary Oscillator Connection.
	CCP2	TTL/ST	—	Capture input.
RC2/AN14/CCP1 <sup>(1)</sup>	RC2	TTL/ST	CMOS	General purpose I/O.
	AN14	AN	—	ADC Channel 14 input.
	CCP1	TTL/ST	—	Capture input.
RC3/AN15/SCK <sup>(1)</sup> /SCL <sup>(1)</sup>	RC3	TTL/ST	CMOS	General purpose I/O.
	AN15	AN	—	ADC Channel 15 input.
	SCK	TTL/ST	—	SPI clock input.
	SCL	I <sup>2</sup> C	OD	I <sup>2</sup> C clock.

**Legend:** AN = Analog input or output    CMOS = CMOS compatible input or output    OD = Open-Drain  
TTL = TTL compatible input    ST = Schmitt Trigger input with CMOS levels    I<sup>2</sup>C = Schmitt Trigger input with I<sup>2</sup>C  
HV = High Voltage    XTAL = Crystal levels

- Note** 1: Default peripheral input. Alternate pins can be selected as the peripheral input with the PPS input selection registers.  
2: All pin digital outputs default to PORT latch data. Alternate outputs can be selected as the peripheral digital output with the PPS output selection registers.  
3: These peripheral functions are bidirectional. The output pin selections must be the same as the input pin selections.

# PIC16(L)F1717/8/9

**TABLE 1-3: PIC16(L)F1717/9 PINOUT DESCRIPTION (CONTINUED)**

Name	Function	Input Type	Output Type	Description
RC4/AN16/SDI <sup>(1)</sup> /SDA <sup>(1)</sup>	RC4	TTL/ST	CMOS	General purpose I/O.
	AN16	AN	—	ADC Channel 16 input.
	SDI	TTL/ST	—	SPI Data input.
	SDA <sup>(3)</sup>	I <sup>2</sup> C	—	I <sup>2</sup> C Data input.
RC5/AN17	RC5	TTL/ST	CMOS	General purpose I/O.
	AN17	AN	—	ADC Channel 17 input.
RC6/AN18/CK <sup>(1)</sup>	RC6	TTL/ST	CMOS	General purpose I/O.
	AN18	AN	—	ADC Channel 18 input.
	CK	TTL/ST	—	EUSART synchronous clock.
RC7/AN19/RX <sup>(1)</sup>	RC7	TTL/ST	CMOS	General purpose I/O.
	AN19	AN	—	ADC Channel 19 input.
	RX	TTL/ST	—	EUSART receive.
RDO/AN20	RD0	TTL/ST	CMOS	General purpose I/O.
	AN20	AN	—	ADC Channel 20 input.
RD1/AN21	RD1	TTL/ST	CMOS	General purpose I/O.
	AN21	AN	—	ADC Channel 21 input.
RD2/AN22	RD2	TTL/ST	CMOS	General purpose I/O.
	AN22	AN	—	ADC Channel 22 input.
RD3/AN23	RD3	TTL/ST	CMOS	General purpose I/O.
	AN23	AN	—	ADC Channel 23 input.
RD4/AN24	RD4	TTL/ST	CMOS	General purpose I/O.
	AN24	AN	—	ADC Channel 24 input.
RD5/AN25	RD5	TTL/ST	CMOS	General purpose I/O.
	AN25	AN	—	ADC Channel 25 input.
RD6/AN26	RD6	TTL/ST	CMOS	General purpose I/O.
	AN26	AN	—	ADC Channel 26 input.
RD7/AN27	RD7	TTL/ST	CMOS	General purpose I/O.
	AN27	AN	—	ADC Channel 27 input.
RE0/AN5	RE0	TTL/ST	CMOS	General purpose I/O.
	AN5	AN	—	ADC Channel 5 input.
RE1/AN6	RE1	TTL/ST	CMOS	General purpose I/O.
	AN6	AN	—	ADC Channel 6 input.
RE2/AN7	RE2	TTL/ST	CMOS	General purpose I/O.
	AN7	AN	—	ADC Channel 7 input.
RE3/MCLR/VPP	RE3	TTL/ST	—	General purpose input.
	MCLR	ST	—	Master clear input.
	VPP	HV	—	Programming voltage.
VDD	VDD	Power	—	Positive supply.
VSS	VSS	Power	—	Ground reference.

**Legend:** AN = Analog input or output    CMOS = CMOS compatible input or output    OD = Open-Drain  
TTL = TTL compatible input    ST = Schmitt Trigger input with CMOS levels    I<sup>2</sup>C = Schmitt Trigger input with I<sup>2</sup>C  
HV = High Voltage    XTAL = Crystal levels

- Note** 1: Default peripheral input. Alternate pins can be selected as the peripheral input with the PPS input selection registers.  
2: All pin digital outputs default to PORT latch data. Alternate outputs can be selected as the peripheral digital output with the PPS output selection registers.  
3: These peripheral functions are bidirectional. The output pin selections must be the same as the input pin selections.

**TABLE 1-3: PIC16(L)F1717/9 PINOUT DESCRIPTION (CONTINUED)**

Name	Function	Input Type	Output Type	Description
OUT <sup>(2)</sup>	C1OUT		CMOS	Comparator 1 output.
	C2OUT		CMOS	Comparator 2 output.
	CCP1		CMOS	Compare/PWM1 output.
	CCP2		CMOS	Compare/PWM2 output.
	NCO1OUT		CMOS	Numerically controlled oscillator output.
	PWM3OUT		CMOS	PWM3 output.
	PWM4OUT		CMOS	PWM4 output.
	COG1A		CMOS	Complementary output generator output A.
	COG1B		CMOS	Complementary output generator output B.
	COG1C		CMOS	Complementary output generator output C.
	COG1D		CMOS	Complementary output generator output D.
	SDA <sup>(3)</sup>		OD	I <sup>2</sup> C Data output.
	SCK		CMOS	SPI clock output.
	SCL <sup>(3)</sup>		OD	I <sup>2</sup> C clock output.
	SDO		CMOS	SPI data output.
	TX/CK		CMOS	EUSART asynchronous TX data/synchronous clock out.
	DT <sup>(3)</sup>		CMOS	EUSART synchronous data output.
	CLC1OUT		CMOS	Configurable Logic Cell 1 output.
	CLC2OUT		CMOS	Configurable Logic Cell 2 output.
	CLC3OUT		CMOS	Configurable Logic Cell 3 output.
CLC4OUT		CMOS	Configurable Logic Cell 4 output.	

**Legend:** AN = Analog input or output    CMOS = CMOS compatible input or output    OD = Open-Drain  
TTL = TTL compatible input    ST = Schmitt Trigger input with CMOS levels    I<sup>2</sup>C = Schmitt Trigger input with I<sup>2</sup>C  
HV = High Voltage    XTAL = Crystal levels

- Note** 1: Default peripheral input. Alternate pins can be selected as the peripheral input with the PPS input selection registers.  
2: All pin digital outputs default to PORT latch data. Alternate outputs can be selected as the peripheral digital output with the PPS output selection registers.  
3: These peripheral functions are bidirectional. The output pin selections must be the same as the input pin selections.

# PIC16(L)F1717/8/9

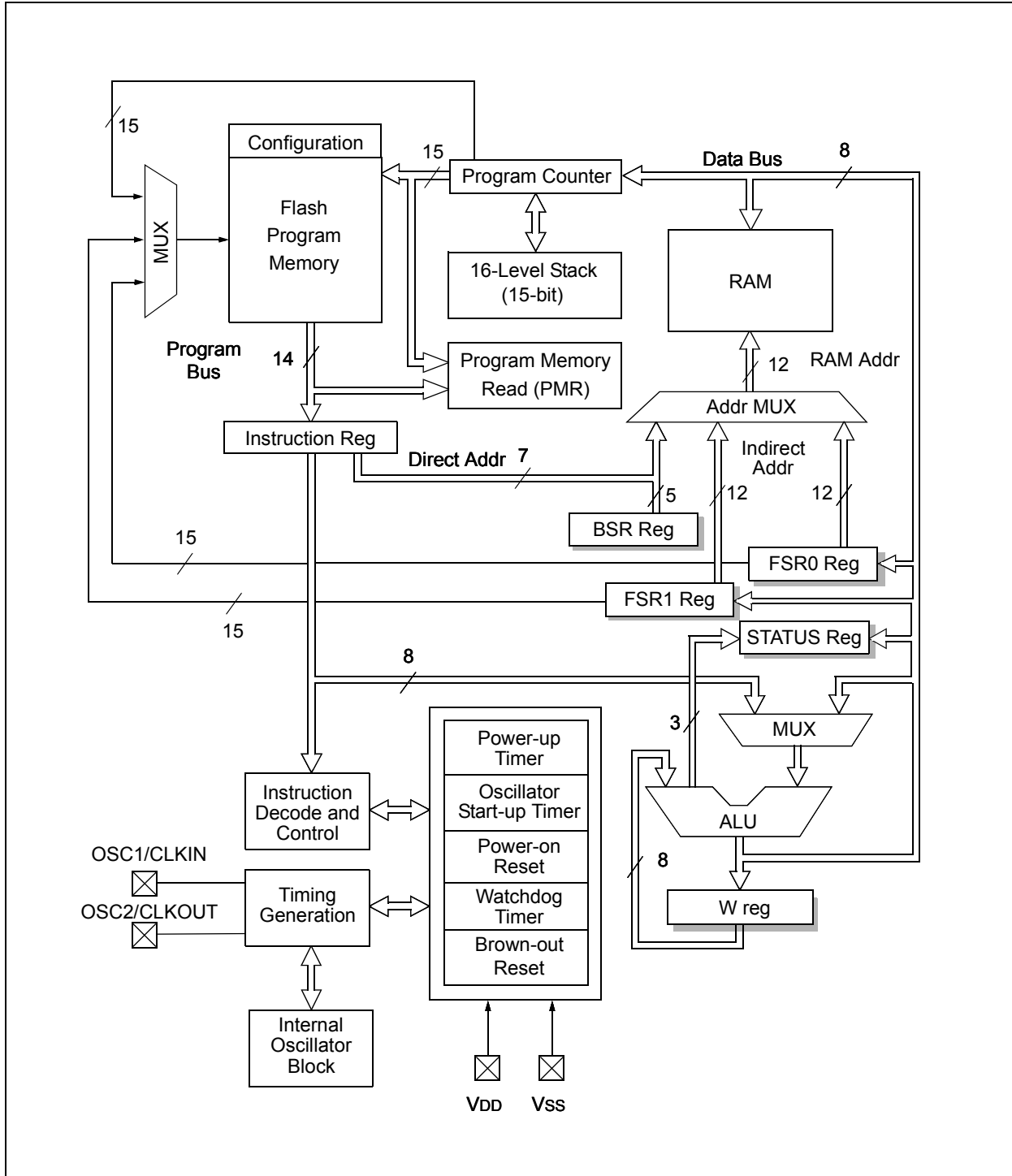
## 2.0 ENHANCED MID-RANGE CPU

This family of devices contains an enhanced mid-range 8-bit CPU core. The CPU has 49 instructions. Interrupt capability includes automatic context saving. The hardware stack is 16 levels deep and has Overflow and Underflow Reset capability. Direct, Indirect and

Relative addressing modes are available. Two File Select Registers (FSRs) provide the ability to read program and data memory.

- Automatic Interrupt Context Saving
- 16-level Stack with Overflow and Underflow
- File Select Registers
- Instruction Set

FIGURE 2-1: CORE BLOCK DIAGRAM



## 2.1 Automatic Interrupt Context Saving

During interrupts, certain registers are automatically saved in shadow registers and restored when returning from the interrupt. This saves stack space and user code. See [Section 7.5 “Automatic Context Saving”](#) for more information.

## 2.2 16-Level Stack with Overflow and Underflow

These devices have a hardware stack memory 15 bits wide and 16 words deep. A Stack Overflow or Underflow will set the appropriate bit (STKOVF or STKUNF) in the PCON register, and if enabled, will cause a software Reset. See [Section 3.6 “Stack”](#) for more details.

## 2.3 File Select Registers

There are two 16-bit File Select Registers (FSR). FSRs can access all file registers and program memory, which allows one Data Pointer for all memory. When an FSR points to program memory, there is one additional instruction cycle in instructions using INDF to allow the data to be fetched. General purpose memory can now also be addressed linearly, providing the ability to access contiguous data larger than 80 bytes. There are also new instructions to support the FSRs. See [Section 3.7 “Indirect Addressing”](#) for more details.

## 2.4 Instruction Set

There are 49 instructions for the enhanced mid-range CPU to support the features of the CPU. See [Section 33.0 “Instruction Set Summary”](#) for more details.

# PIC16(L)F1717/8/9

## 3.0 MEMORY ORGANIZATION

These devices contain the following types of memory:

- Program Memory
  - Configuration Words
  - Device ID
  - User ID
  - Flash Program Memory
- Data Memory
  - Core Registers
  - Special Function Registers
  - General Purpose RAM
  - Common RAM

**Note 1:** The method to access Flash memory through the PMCON registers is described in [Section 10.0 “Flash Program Memory Control”](#).

The following features are associated with access and control of program memory and data memory:

- PCL and PCLATH
- Stack
- Indirect Addressing

## 3.1 Program Memory Organization

The enhanced mid-range core has a 15-bit program counter capable of addressing a 32K x 14 program memory space. [Table 3-1](#) shows the memory sizes implemented for the PIC16(L)F1717/8/9 family. Accessing a location above these boundaries will cause a wrap-around within the implemented memory space. The Reset vector is at 0000h and the interrupt vector is at 0004h (see [Figure 3-1](#)).

## 3.2 High-Endurance Flash

This device has a 128-byte section of high-endurance program Flash memory (PFM) in lieu of data EEPROM. This area is especially well suited for nonvolatile data storage that is expected to be updated frequently over the life of the end product. See [Section 10.2 “Flash Program Memory Overview”](#) for more information on writing data to PFM. See [Section 3.2.1.2 “Indirect Read with FSR”](#) for more information about using the FSR registers to read byte data stored in PFM.

**TABLE 3-1: DEVICE SIZES AND ADDRESSES**

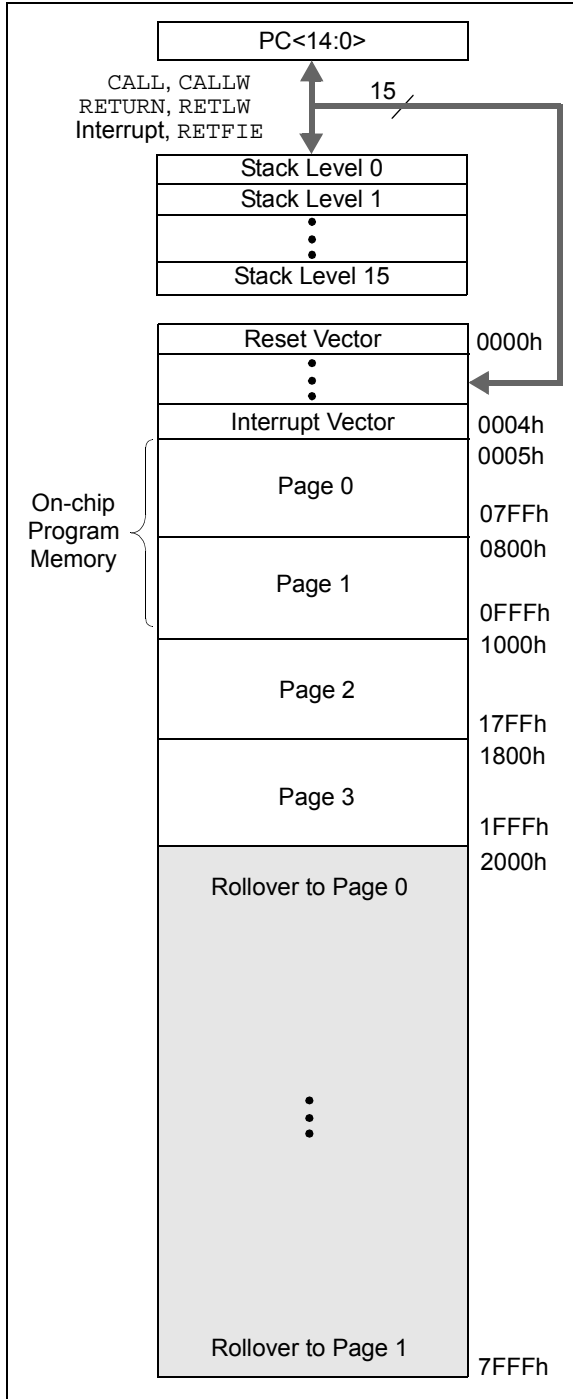
Device	Program Memory Space (Words)	Last Program Memory Address	High-Endurance Flash Memory Address Range <sup>(1)</sup>
PIC16(L)F1717	8,192	1FFFh	1F80h-1FFFh
PIC16(L)F1718/9	16,384	3FFFh	3F80h-3FFFh

**Note 1:** High-endurance Flash applies to the low byte of each address in the range.

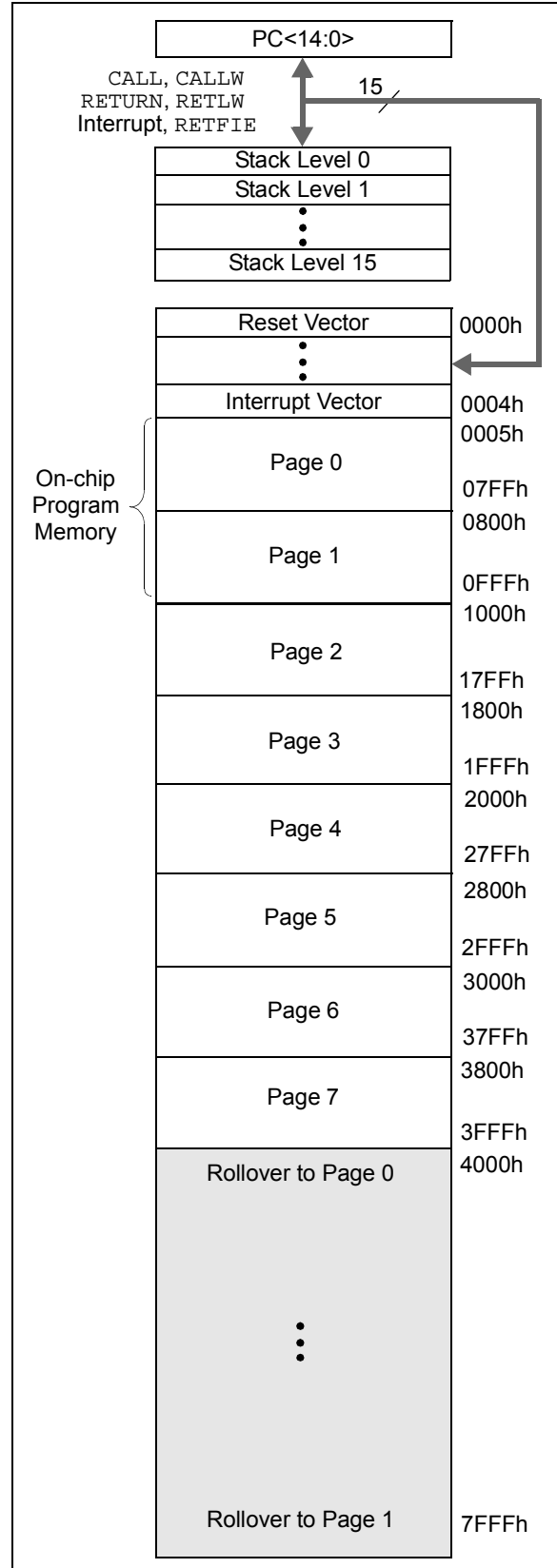


# PIC16(L)F1717/8/9

**FIGURE 3-1: PROGRAM MEMORY MAP AND STACK FOR PIC16(L)F1717**



**FIGURE 3-2: PROGRAM MEMORY MAP AND STACK FOR PIC16(L)F1718/9**



# PIC16(L)F1717/8/9

## 3.2.1 READING PROGRAM MEMORY AS DATA

There are two methods of accessing constants in program memory. The first method is to use tables of RETLW instructions. The second method is to set an FSR to point to the program memory.

### 3.2.1.1 RETLW Instruction

The RETLW instruction can be used to provide access to tables of constants. The recommended way to create such a table is shown in [Example 3-1](#).

#### EXAMPLE 3-1: RETLW INSTRUCTION

```
constants
  BRW          ;Add Index in W to
              ;program counter to
              ;select data
  RETLW DATA0 ;Index0 data
  RETLW DATA1 ;Index1 data
  RETLW DATA2
  RETLW DATA3

my_function
  ;... LOTS OF CODE...
  MOVLW      DATA_INDEX
  call constants
  ;... THE CONSTANT IS IN W
```

The BRW instruction makes this type of table very simple to implement. If your code must remain portable with previous generations of microcontrollers, then the BRW instruction is not available, so the older table read method must be used.

### 3.2.1.2 Indirect Read with FSR

The program memory can be accessed as data by setting bit 7 of the FSRxH register and reading the matching INDFx register. The MOVIW instruction will place the lower eight bits of the addressed word in the W register. Writes to the program memory cannot be performed via the INDF registers. Instructions that access the program memory via the FSR require one extra instruction cycle to complete. [Example 3-2](#) demonstrates accessing the program memory via an FSR.

The high directive will set bit<7> if a label points to a location in program memory.

#### EXAMPLE 3-2: ACCESSING PROGRAM MEMORY VIA FSR

```
constants
  DW DATA0          ;First constant
  DW DATA1          ;Second constant
  DW DATA2
  DW DATA3

my_function
  ;... LOTS OF CODE...
  MOVLW      DATA_INDEX
  ADDLW     LOW constants
  MOVWF     FSR1L
  MOVLW     HIGH constants;MSb sets
                          automatically
  MOVWF     FSR1H
  BTFSK     STATUS, C    ;carry from ADDLW?
  INCF     FSR1H, f     ;yes
  MOVIW     0[FSR1]
  ;THE PROGRAM MEMORY IS IN W
```

## 3.3 Data Memory Organization

The data memory is partitioned in 32 memory banks with 128 bytes in a bank. Each bank consists of (see [Figure 3-3](#)):

- 12 core registers
- 20 Special Function Registers (SFR)
- Up to 80 bytes of General Purpose RAM (GPR)
- 16 bytes of common RAM

The active bank is selected by writing the bank number into the Bank Select Register (BSR). Unimplemented memory will read as '0'. All data memory can be accessed either directly (via instructions that use the file registers) or indirectly via the two File Select Registers (FSR). See [Section 3.7 "Indirect Addressing"](#) for more information.

Data memory uses a 12-bit address. The upper five bits of the address define the Bank address and the lower seven bits select the registers/RAM in that bank.

### 3.3.1 CORE REGISTERS

The core registers contain the registers that directly affect the basic operation. The core registers occupy the first 12 addresses of every data memory bank (addresses x00h/x08h through x0Bh/x8Bh). These registers are listed below in [Table 3-2](#). For detailed information, see [Table 3-11](#).

**TABLE 3-2: CORE REGISTERS**

Addresses	BANKx
x00h or x80h	INDF0
x01h or x81h	INDF1
x02h or x82h	PCL
x03h or x83h	STATUS
x04h or x84h	FSR0L
x05h or x85h	FSR0H
x06h or x86h	FSR1L
x07h or x87h	FSR1H
x08h or x88h	BSR
x09h or x89h	WREG
x0Ah or x8Ah	PCLATH
x0Bh or x8Bh	INTCON

### 3.3.1.1 STATUS Register

The STATUS register, shown in [Register 3-1](#), contains:

- The arithmetic status of the ALU
- The Reset status

The STATUS register can be the destination for any instruction, like any other register. If the STATUS register is the destination for an instruction that affects the Z, DC or C bits, then the write to these three bits is disabled. These bits are set or cleared according to the device logic. Furthermore, the TO and PD bits are not writable. Therefore, the result of an instruction with the STATUS register as destination may be different than intended.

For example, `CLRF STATUS` will clear the upper three bits and set the Z bit. This leaves the STATUS register as '000u u1uu' (where u = unchanged).

It is recommended, therefore, that only `BCF`, `BSF`, `SWAPF` and `MOVWF` instructions are used to alter the STATUS register, because these instructions do not affect any Status bits. For other instructions not affecting any Status bits (Refer to [Section 33.0 "Instruction Set Summary"](#)).

**Note:** The C and DC bits operate as Borrow and Digit Borrow out bits, respectively, in subtraction.

# PIC16(L)F1717/8/9

## 3.4 Register Definitions: Status

### REGISTER 3-1: STATUS: STATUS REGISTER

U-0	U-0	U-0	R-1/q	R-1/q	R/W-0/u	R/W-0/u	R/W-0/u
—	—	—	$\overline{\text{TO}}$	$\overline{\text{PD}}$	Z	DC <sup>(1)</sup>	C <sup>(1)</sup>
bit 7							bit 0

#### Legend:

R = Readable bit	W = Writable bit	U = Unimplemented bit, read as '0'
u = Bit is unchanged	x = Bit is unknown	-n/n = Value at POR and BOR/Value at all other Resets
'1' = Bit is set	'0' = Bit is cleared	q = Value depends on condition

bit 7-5 **Unimplemented:** Read as '0'

bit 4  **$\overline{\text{TO}}$ :** Time-Out bit

- 1 = After power-up, CLRWD $\overline{\text{T}}$  instruction or SLEEP instruction
- 0 = A WDT Time-out occurred

bit 3  **$\overline{\text{PD}}$ :** Power-Down bit

- 1 = After power-up or by the CLRWD $\overline{\text{T}}$  instruction
- 0 = By execution of the SLEEP instruction

bit 2 **Z:** Zero bit

- 1 = The result of an arithmetic or logic operation is zero
- 0 = The result of an arithmetic or logic operation is not zero

bit 1 **DC:** Digit Carry/Digit Borrow bit (ADDWF, ADDLW, SUBLW, SUBWF instructions)<sup>(1)</sup>

- 1 = A carry-out from the 4th low-order bit of the result occurred
- 0 = No carry-out from the 4th low-order bit of the result

bit 0 **C:** Carry/Borrow bit<sup>(1)</sup> (ADDWF, ADDLW, SUBLW, SUBWF instructions)<sup>(1)</sup>

- 1 = A carry-out from the Most Significant bit of the result occurred
- 0 = No carry-out from the Most Significant bit of the result occurred

**Note 1:** For Borrow, the polarity is reversed. A subtraction is executed by adding the two's complement of the second operand.

## 3.4.1 SPECIAL FUNCTION REGISTER

The Special Function Registers are registers used by the application to control the desired operation of peripheral functions in the device. The Special Function Registers occupy the 20 bytes after the core registers of every data memory bank (addresses x0Ch/x8Ch through x1Fh/x9Fh). The registers associated with the operation of the peripherals are described in the appropriate peripheral chapter of this data sheet.

## 3.4.2 GENERAL PURPOSE RAM

There are up to 80 bytes of GPR in each data memory bank. The GPR occupies the 80 bytes after the SFR registers of selected data memory banks.

### 3.4.2.1 Linear Access to GPR

The general purpose RAM can be accessed in a non-banked method via the FSRs. This can simplify access to large memory structures. See [Section 3.7.2 “Linear Data Memory”](#) for more information.

## 3.4.3 COMMON RAM

There are 16 bytes of common RAM accessible from all banks.

## 3.4.4 DEVICE MEMORY MAPS

The memory maps for the device family are as shown in [Table 3-3](#) through [Table 3-10](#).

**FIGURE 3-3: BANKED MEMORY PARTITIONING**

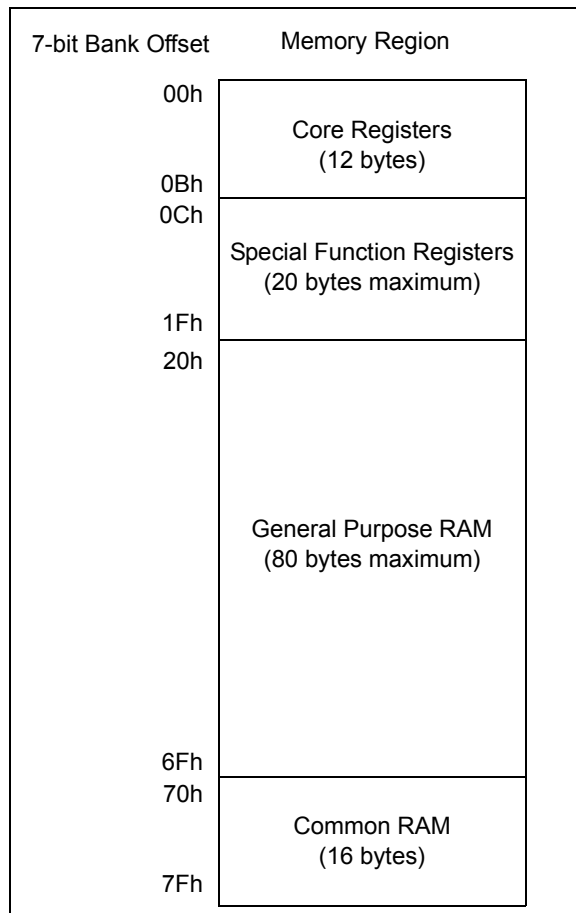


TABLE 3-3: PIC16(L)F1718 MEMORY MAP (BANKS 0-7)

BANK 0		BANK 1		BANK 2		BANK 3		BANK 4		BANK 5		BANK 6		BANK 7	
000h	Core Registers (Table 3-2)	080h	Core Registers (Table 3-2)	100h	Core Registers (Table 3-2)	180h	Core Registers (Table 3-2)	200h	Core Registers (Table 3-2)	280h	Core Registers (Table 3-2)	300h	Core Registers (Table 3-2)	380h	Core Registers (Table 3-2)
00Bh		08Bh		10Bh		18Bh		20Bh		28Bh		30Bh		38Bh	
00Ch	PORTA	08Ch	TRISA	10Ch	LATA	18Ch	ANSELA	20Ch	WPUA	28Ch	ODCONA	30Ch	SLRCONA	38Ch	INLVLA
00Dh	PORTB	08Dh	TRISB	10Dh	LATB	18Dh	ANSELB	20Dh	WPUB	28Dh	ODCONB	30Dh	SLRCONB	38Dh	INLVLB
00Eh	PORTC	08Eh	TRISC	10Eh	LATC	18Eh	ANSELC	20Eh	WPUC	28Eh	ODCONC	30Eh	SLRCONC	38Eh	INLVLC
00Fh	—	08Fh	—	10Fh	—	18Fh	—	20Fh	—	28Fh	—	30Fh	—	38Fh	—
010h	PORTE	090h	TRISE	110h	—	190h	—	210h	WPUE	290h	—	310h	—	390h	INLVLE
011h	PIR1	091h	PIE1	111h	CM1CON0	191h	PMADRL	211h	SSP1BUF	291h	CCPR1L	311h	—	391h	IOCAP
012h	PIR2	092h	PIE2	112h	CM1CON1	192h	PMADRH	212h	SSP1ADD	292h	CCPR1H	312h	—	392h	IOCAN
013h	PIR3	093h	PIE3	113h	CM2CON0	193h	PMDATL	213h	SSP1MSK	293h	CCP1CON	313h	—	393h	IOCAF
014h	—	094h	—	114h	CM2CON1	194h	PMDATH	214h	SSP1STAT	294h	—	314h	—	394h	IOCBP
015h	TMR0	095h	OPTION_REG	115h	CMOUT	195h	PMCON1	215h	SSP1CON1	295h	—	315h	—	395h	IOCBN
016h	TMR1L	096h	PCON	116h	BORCON	196h	PMCON2	216h	SSP1CON2	296h	—	316h	—	396h	IOCBF
017h	TMR1H	097h	WDTCON	117h	FVRCON	197h	VREGCON <sup>(1)</sup>	217h	SSP1CON3	297h	—	317h	—	397h	IOCCP
018h	T1CON	098h	OSCTUNE	118h	DAC1CON0	198h	—	218h	—	298h	CCPR2L	318h	—	398h	IOCCN
019h	T1GCON	099h	OSCCON	119h	DAC1CON1	199h	RC1REG	219h	—	299h	CCPR2H	319h	—	399h	IOCCF
01Ah	TMR2	09Ah	OSCSTAT	11Ah	DAC2CON0	19Ah	TX1REG	21Ah	—	29Ah	CCP2CON	31Ah	—	39Ah	—
01Bh	PR2	09Bh	ADRESL	11Bh	DAC2CON1	19Bh	SP1BRGL	21Bh	—	29Bh	—	31Bh	—	39Bh	—
01Ch	T2CON	09Ch	ADRESH	11Ch	ZCD1CON	19Ch	SP1BRGH	21Ch	—	29Ch	—	31Ch	—	39Ch	—
01Dh	—	09Dh	ADCON0	11Dh	—	19Dh	RC1STA	21Dh	—	29Dh	—	31Dh	—	39Dh	IOCEP
01Eh	—	09Eh	ADCON1	11Eh	—	19Eh	TX1STA	21Eh	—	29Eh	CCPTMRS	31Eh	—	39Eh	IOCEN
01Fh	—	09Fh	ADCON2	11Fh	—	19Fh	BAUD1CON	21Fh	—	29Fh	—	31Fh	—	39Fh	IOCEF
020h	General Purpose Register 80 Bytes	0A0h	General Purpose Register 80 Bytes	120h	General Purpose Register 80 Bytes	1A0h	General Purpose Register 80 Bytes	220h	General Purpose Register 80 Bytes	2A0h	General Purpose Register 80 Bytes	320h	General Purpose Register 80 Bytes	3A0h	General Purpose Register 80 Bytes
06Fh		0EFh		16Fh		1EFh		26Fh		2EFh		36Fh		3EFh	
070h	Common RAM 70h – 7Fh	0F0h	Accesses 70h – 7Fh	170h	Accesses 70h – 7Fh	1F0h	Accesses 70h – 7Fh	270h	Accesses 70h – 7Fh	2F0h	Accesses 70h – 7Fh	370h	Accesses 70h – 7Fh	3F0h	Accesses 70h – 7Fh
07Fh		0FFh		17Fh		1FFh		27Fh		2FFh		37Fh		3FFh	

Legend: ■ = Unimplemented data memory locations, read as '0'.

Note 1: Unimplemented on PIC16LF1718/9.

**TABLE 3-4: PIC16(L)F1717/9 MEMORY MAP (BANKS 0-7)**

BANK 0		BANK 1		BANK 2		BANK 3		BANK 4		BANK 5		BANK 6		BANK 7	
000h	Core Registers (Table 3-2)	080h	Core Registers (Table 3-2)	100h	Core Registers (Table 3-2)	180h	Core Registers (Table 3-2)	200h	Core Registers (Table 3-2)	280h	Core Registers (Table 3-2)	300h	Core Registers (Table 3-2)	380h	Core Registers (Table 3-2)
00Bh		08Bh		10Bh		18Bh		20Bh		28Bh		30Bh		38Bh	
00Ch	PORTA	08Ch	TRISA	10Ch	LATA	18Ch	ANSELA	20Ch	WPUA	28Ch	ODCONA	30Ch	SLRCONA	38Ch	INLVLA
00Dh	PORTB	08Dh	TRISB	10Dh	LATB	18Dh	ANSELB	20Dh	WPUB	28Dh	ODCONB	30Dh	SLRCONB	38Dh	INLVLB
00Eh	PORTC	08Eh	TRISC	10Eh	LATC	18Eh	ANSELC	20Eh	WPUC	28Eh	ODCONC	30Eh	SLRCONC	38Eh	INLVLC
00Fh	PORTD	08Fh	TRISD	10Fh	LATD	18Fh	ANSELD	20Fh	WPUD	28Fh	ODCOND	30Fh	SLRCOND	38Fh	INLVLE
010h	PORTE	090h	TRISE	110h	LATE	190h	ANSELE	210h	WPUE	290h	ODCONE	310h	SLRCONE	390h	INLVLE
011h	PIR1	091h	PIE1	111h	CM1CON0	191h	PMADRL	211h	SSP1BUF	291h	CCPR1L	311h	—	391h	IOCAP
012h	PIR2	092h	PIE2	112h	CM1CON1	192h	PMADRH	212h	SSP1ADD	292h	CCPR1H	312h	—	392h	IOCAN
013h	PIR3	093h	PIE3	113h	CM2CON0	193h	PMDATL	213h	SSP1MSK	293h	CCP1CON	313h	—	393h	IOCAF
014h	—	094h	—	114h	CM2CON1	194h	PMDATH	214h	SSP1STAT	294h	—	314h	—	394h	IOCBP
015h	TMR0	095h	OPTION_REG	115h	CMOUT	195h	PMCON1	215h	SSP1CON1	295h	—	315h	—	395h	IOCBN
016h	TMR1L	096h	PCON	116h	BORCON	196h	PMCON2	216h	SSP1CON2	296h	—	316h	—	396h	IOCBF
017h	TMR1H	097h	WDTCON	117h	FVRCON	197h	VREGCON <sup>(1)</sup>	217h	SSP1CON3	297h	—	317h	—	397h	IOCCP
018h	T1CON	098h	OSCTUNE	118h	DAC1CON0	198h	—	218h	—	298h	CCPR2L	318h	—	398h	IOCCN
019h	T1GCON	099h	OSCCON	119h	DAC1CON1	199h	RC1REG	219h	—	299h	CCPR2H	319h	—	399h	IOCCF
01Ah	TMR2	09Ah	OSCSTAT	11Ah	DAC2CON0	19Ah	TX1REG	21Ah	—	29Ah	CCP2CON	31Ah	—	39Ah	—
01Bh	PR2	09Bh	ADRESL	11Bh	DAC2CON1	19Bh	SP1BRGL	21Bh	—	29Bh	—	31Bh	—	39Bh	—
01Ch	T2CON	09Ch	ADRESH	11Ch	ZCD1CON	19Ch	SP1BRGH	21Ch	—	29Ch	—	31Ch	—	39Ch	—
01Dh	—	09Dh	ADCON0	11Dh	—	19Dh	RC1STA	21Dh	—	29Dh	—	31Dh	—	39Dh	IOCEP
01Eh	—	09Eh	ADCON1	11Eh	—	19Eh	TX1STA	21Eh	—	29Eh	CCPTMRS	31Eh	—	39Eh	IOCEN
01Fh	—	09Fh	ADCON2	11Fh	—	19Fh	BAUD1CON	21Fh	—	29Fh	—	31Fh	—	39Fh	IOCEF
020h	General Purpose Register 80 Bytes	0A0h	General Purpose Register 80 Bytes	120h	General Purpose Register 80 Bytes	1A0h	General Purpose Register 80 Bytes	220h	General Purpose Register 80 Bytes	2A0h	General Purpose Register 80 Bytes	320h	General Purpose Register 80 Bytes	3A0h	General Purpose Register 80 Bytes
06Fh		0EFh		16Fh		1EFh		26Fh		2EFh		36Fh		3EFh	
070h	Common RAM 70h – 7Fh	0F0h	Accesses 70h – 7Fh	170h	Accesses 70h – 7Fh	1F0h	Accesses 70h – 7Fh	270h	Accesses 70h – 7Fh	2F0h	Accesses 70h – 7Fh	370h	Accesses 70h – 7Fh	3F0h	Accesses 70h – 7Fh
07Fh		0FFh		17Fh		1FFh		27Fh		2FFh		37Fh		3FFh	

**Legend:** ■ = Unimplemented data memory locations, read as '0'.

**Note 1:** Unimplemented on PIC16LF1717/8/9.

**TABLE 3-5: PIC16(L)F1717 MEMORY MAP, BANK 8-23**

BANK 8		BANK 9		BANK 10		BANK 11		BANK 12		BANK 13		BANK 14		BANK 15	
400h	Core Registers (Table 3-2)	480h	Core Registers (Table 3-2)	500h	Core Registers (Table 3-2)	580h	Core Registers (Table 3-2)	600h	Core Registers (Table 3-2)	680h	Core Registers (Table 3-2)	700h	Core Registers (Table 3-2)	780h	Core Registers (Table 3-2)
40Bh	—	48Bh	—	50Bh	—	58Bh	—	60Bh	—	68Bh	—	70Bh	—	78Bh	—
40Ch	—	48Ch	—	50Ch	—	58Ch	—	60Ch	—	68Ch	—	70Ch	—	78Ch	—
40Dh	—	48Dh	—	50Dh	—	58Dh	—	60Dh	—	68Dh	—	70Dh	—	78Dh	—
40Eh	—	48Eh	—	50Eh	—	58Eh	—	60Eh	—	68Eh	—	70Eh	—	78Eh	—
40Fh	—	48Fh	—	50Fh	—	58Fh	—	60Fh	—	68Fh	—	70Fh	—	78Fh	—
410h	—	490h	—	510h	—	590h	—	610h	—	690h	—	710h	—	790h	—
411h	—	491h	—	511h	OPA1CON	591h	—	611h	—	691h	COG1PHR	711h	—	791h	—
412h	—	492h	—	512h	—	592h	—	612h	—	692h	COG1PHF	712h	—	792h	—
413h	—	493h	—	513h	—	593h	—	613h	—	693h	COG1BLKR	713h	—	793h	—
414h	—	494h	—	514h	—	594h	—	614h	—	694h	COG1BLKF	714h	—	794h	—
415h	TMR4	495h	—	515h	OPA2CON	595h	—	615h	—	695h	COG1DBR	715h	—	795h	—
416h	PR4	496h	—	516h	—	596h	—	616h	—	696h	COG1DBF	716h	—	796h	—
417h	T4CON	497h	—	517h	—	597h	—	617h	PWM3DCL	697h	COG1CON0	717h	—	797h	—
418h	—	498h	NCO1ACCL	518h	—	598h	—	618h	PWM3DCH	698h	COG1CON1	718h	—	798h	—
419h	—	499h	NCO1ACCH	519h	—	599h	—	619h	PWM3CON	699h	COG1RIS	719h	—	799h	—
41Ah	—	49Ah	NCO1ACCU	51Ah	—	59Ah	—	61Ah	PWM4DCL	69Ah	COG1RSIM	71Ah	—	79Ah	—
41Bh	—	49Bh	NCO1INCL	51Bh	—	59Bh	—	61Bh	PWM4DCH	69Bh	COG1FIS	71Bh	—	79Bh	—
41Ch	TMR6	49Ch	NCO1INCH	51Ch	—	59Ch	—	61Ch	PWM4CON	69Ch	COG1FSIM	71Ch	—	79Ch	—
41Dh	PR6	49Dh	NCO1INCU	51Dh	—	59Dh	—	61Dh	—	69Dh	COG1ASD0	71Dh	—	79Dh	—
41Eh	T6CON	49Eh	NCO1CON	51Eh	—	59Eh	—	61Eh	—	69Eh	COG1ASD1	71Eh	—	79Eh	—
41Fh	—	49Fh	NCO1CLK	51Fh	—	59Fh	—	61Fh	—	69Fh	COG1STR	71Fh	—	79Fh	—
420h	General Purpose Register 80 Bytes	4A0h	General Purpose Register 80 Bytes	520h	General Purpose Register 80 Bytes	5A0h	General Purpose Register 80 Bytes	620h	General Purpose Register 48 Bytes	6A0h	Unimplemented Read as '0'	720h	Unimplemented Read as '0'	7A0h	Unimplemented Read as '0'
46Fh	—	4EFh	—	56Fh	—	5EFh	—	64Fh	Unimplemented Read as '0'	64Fh	—	76Fh	—	7EFh	—
470h	Accesses 70h – 7Fh	4F0h	Accesses 70h – 7Fh	570h	Accesses 70h – 7Fh	5F0h	Accesses 70h – 7Fh	650h	—	650h	—	770h	Accesses 70h – 7Fh	7F0h	Accesses 70h – 7Fh
47Fh	—	4FFh	—	57Fh	—	5FFh	—	66Fh	Accesses 70h – 7Fh	66Fh	Accesses 70h – 7Fh	77Fh	—	7FFh	Accesses 70h – 7Fh
800h	Core Registers (Table 3-2)	880h	Core Registers (Table 3-2)	900h	Core Registers (Table 3-2)	980h	Core Registers (Table 3-2)	A00h	Core Registers (Table 3-2)	A80h	Core Registers (Table 3-2)	B00h	Core Registers (Table 3-2)	B80h	Core Registers (Table 3-2)
80Bh	—	88Bh	—	90Bh	—	98Bh	—	A0Bh	—	A8Bh	—	B0Bh	—	B8Bh	—
80Ch	Unimplemented Read as '0'	88Ch	Unimplemented Read as '0'	90Ch	Unimplemented Read as '0'	98Ch	Unimplemented Read as '0'	A0Ch	Unimplemented Read as '0'	A8Ch	Unimplemented Read as '0'	B0Ch	Unimplemented Read as '0'	B8Ch	Unimplemented Read as '0'
86Fh	—	8EFh	—	96Fh	—	9EFh	—	A6Fh	—	AEFh	—	B6Fh	—	BEFh	—
870h	Accesses 70h – 7Fh	8F0h	Accesses 70h – 7Fh	970h	Accesses 70h – 7Fh	9F0h	Accesses 70h – 7Fh	A70h	Accesses 70h – 7Fh	AF0h	Accesses 70h – 7Fh	B70h	Accesses 70h – 7Fh	BF0h	Accesses 70h – 7Fh
87Fh	—	8FFh	—	97Fh	—	9FFh	—	A7Fh	—	AFh	—	B7Fh	—	BFh	—

**Legend:**  = Unimplemented data memory locations, read as '0'.



**TABLE 3-6: PIC16(L)F1718/9 MEMORY MAP, BANK 8-23**

BANK 8		BANK 9		BANK 10		BANK 11		BANK 12		BANK 13		BANK 14		BANK 15	
400h	Core Registers (Table 3-2)	480h	Core Registers (Table 3-2)	500h	Core Registers (Table 3-2)	580h	Core Registers (Table 3-2)	600h	Core Registers (Table 3-2)	680h	Core Registers (Table 3-2)	700h	Core Registers (Table 3-2)	780h	Core Registers (Table 3-2)
40Bh	—	48Bh	—	50Bh	—	58Bh	—	60Bh	—	68Bh	—	70Bh	—	78Bh	—
40Ch	—	48Ch	—	50Ch	—	58Ch	—	60Ch	—	68Ch	—	70Ch	—	78Ch	—
40Dh	—	48Dh	—	50Dh	—	58Dh	—	60Dh	—	68Dh	—	70Dh	—	78Dh	—
40Eh	—	48Eh	—	50Eh	—	58Eh	—	60Eh	—	68Eh	—	70Eh	—	78Eh	—
40Fh	—	48Fh	—	50Fh	—	58Fh	—	60Fh	—	68Fh	—	70Fh	—	78Fh	—
410h	—	490h	—	510h	—	590h	—	610h	—	690h	—	710h	—	790h	—
411h	—	491h	—	511h	OPA1CON	591h	—	611h	—	691h	COG1PHR	711h	—	791h	—
412h	—	492h	—	512h	—	592h	—	612h	—	692h	COG1PHF	712h	—	792h	—
413h	—	493h	—	513h	—	593h	—	613h	—	693h	COG1BLKR	713h	—	793h	—
414h	—	494h	—	514h	—	594h	—	614h	—	694h	COG1BLKF	714h	—	794h	—
415h	TMR4	495h	—	515h	OPA2CON	595h	—	615h	—	695h	COG1DBR	715h	—	795h	—
416h	PR4	496h	—	516h	—	596h	—	616h	—	696h	COG1DBF	716h	—	796h	—
417h	T4CON	497h	—	517h	—	597h	—	617h	PWM3DCL	697h	COG1CON0	717h	—	797h	—
418h	—	498h	NCO1ACCL	518h	—	598h	—	618h	PWM3DCH	698h	COG1CON1	718h	—	798h	—
419h	—	499h	NCO1ACCH	519h	—	599h	—	619h	PWM3CON	699h	COG1RIS	719h	—	799h	—
41Ah	—	49Ah	NCO1ACCU	51Ah	—	59Ah	—	61Ah	PWM4DCL	69Ah	COG1RSIM	71Ah	—	79Ah	—
41Bh	—	49Bh	NCO1INCL	51Bh	—	59Bh	—	61Bh	PWM4DCH	69Bh	COG1FIS	71Bh	—	79Bh	—
41Ch	TMR6	49Ch	NCO1INCH	51Ch	—	59Ch	—	61Ch	PWM4CON	69Ch	COG1FSIM	71Ch	—	79Ch	—
41Dh	PR6	49Dh	NCO1INCU	51Dh	—	59Dh	—	61Dh	—	69Dh	COG1ASD0	71Dh	—	79Dh	—
41Eh	T6CON	49Eh	NCO1CON	51Eh	—	59Eh	—	61Eh	—	69Eh	COG1ASD1	71Eh	—	79Eh	—
41Fh	—	49Fh	NCO1CLK	51Fh	—	59Fh	—	61Fh	—	69Fh	COG1STR	71Fh	—	79Fh	—
420h	General Purpose Register 80 Bytes	4A0h	General Purpose Register 80 Bytes	520h	General Purpose Register 80 Bytes	5A0h	General Purpose Register 80 Bytes	620h	General Purpose Register 80 Bytes	6A0h	General Purpose Register 80 Bytes	720h	General Purpose Register 80 Bytes	7A0h	General Purpose Register 80 Bytes
46Fh	—	4EFh	—	56Fh	—	5EFh	—	66Fh	—	6EFh	—	76Fh	—	7EFh	—
470h	Accesses 70h – 7Fh	4F0h	Accesses 70h – 7Fh	570h	Accesses 70h – 7Fh	5F0h	Accesses 70h – 7Fh	670h	Accesses 70h – 7Fh	6F0h	Accesses 70h – 7Fh	770h	Accesses 70h – 7Fh	7F0h	Accesses 70h – 7Fh
47Fh	—	4FFh	—	57Fh	—	5FFh	—	67Fh	—	6FFh	—	77Fh	—	7FFh	—
BANK 16		BANK 17		BANK 18		BANK 19		BANK 20		BANK 21		BANK 22		BANK 23	
800h	Core Registers (Table 3-2)	880h	Core Registers (Table 3-2)	900h	Core Registers (Table 3-2)	980h	Core Registers (Table 3-2)	A00h	Core Registers (Table 3-2)	A80h	Core Registers (Table 3-2)	B00h	Core Registers (Table 3-2)	B80h	Core Registers (Table 3-2)
80Bh	—	88Bh	—	90Bh	—	98Bh	—	A0Bh	—	A8Bh	—	B0Bh	—	B8Bh	—
80Ch	General Purpose Register 80 Bytes	88Ch	General Purpose Register 80 Bytes	90Ch	General Purpose Register 80 Bytes	98Ch	General Purpose Register 80 Bytes	A0Ch	General Purpose Register 80 Bytes	A8Ch	General Purpose Register 80 Bytes	B0Ch	General Purpose Register 80 Bytes	B8Ch	General Purpose Register 80 Bytes
86Fh	—	8EFh	—	96Fh	—	9EFh	—	A6Fh	—	A6Fh	—	B6Fh	—	BEFh	—
870h	Accesses 70h – 7Fh	8F0h	Accesses 70h – 7Fh	970h	Accesses 70h – 7Fh	9F0h	Accesses 70h – 7Fh	A70h	Accesses 70h – 7Fh	AF0h	Accesses 70h – 7Fh	B70h	Accesses 70h – 7Fh	BF0h	Accesses 70h – 7Fh
87Fh	—	8FFh	—	97Fh	—	9FFh	—	A7Fh	—	AFh	—	B7Fh	—	BFh	—

Legend:  = Unimplemented data memory locations, read as '0'.

TABLE 3-7: PIC16(L)F1717 MEMORY MAP, BANK 24-31

BANK 24		BANK 25		BANK 26		BANK 27		BANK 28		BANK 29		BANK 30		BANK 31	
C00h	Core Registers (Table 3-2)	C80h	Core Registers (Table 3-2)	D00h	Core Registers (Table 3-2)	D80h	Core Registers (Table 3-2)	E00h	Core Registers (Table 3-2)	E80h	Core Registers (Table 3-2)	F00h	Core Registers (Table 3-2)	F80h	Core Registers (Table 3-2)
C0Bh	—	C8Bh	—	D0Bh	—	D8Bh	—	E0Bh	—	E8Bh	—	F0Bh	—	F8Bh	—
C0Ch	—	C8Ch	—	D0Ch	—	D8Ch	—	E0Ch	—	E8Ch	—	F0Ch	—	F8Ch	—
C0Dh	—	C8Dh	—	D0Dh	—	D8Dh	—	E0Dh	—	E8Dh	—	F0Dh	—	F8Dh	—
C0Eh	—	C8Eh	—	D0Eh	—	D8Eh	—	E0Eh	—	E8Eh	—	F0Eh	—	F8Eh	—
C0Fh	—	C8Fh	—	D0Fh	—	D8Fh	—	E0Fh	—	E8Fh	—	F0Fh	—	F8Fh	—
C10h	—	C90h	—	D10h	—	D90h	—	E10h	—	E90h	—	F10h	—	F90h	—
C11h	—	C91h	—	D11h	—	D91h	—	E11h	—	E91h	—	F11h	—	F91h	—
C12h	—	C92h	—	D12h	—	D92h	—	E12h	—	E92h	—	F12h	—	F92h	—
C13h	—	C93h	—	D13h	—	D93h	—	E13h	—	E93h	—	F13h	—	F93h	—
C14h	—	C94h	—	D14h	—	D94h	—	E14h	—	E94h	—	F14h	—	F94h	—
C15h	—	C95h	—	D15h	—	D95h	—	E15h	—	E95h	—	F15h	—	F95h	—
C16h	—	C96h	—	D16h	—	D96h	—	E16h	—	E96h	—	F16h	—	F96h	—
C17h	—	C97h	—	D17h	—	D97h	—	E17h	See Table 3-9 for register mapping details	E97h	See Table 3-9 for register mapping details	F17h	See Table 3-9 for register mapping details	F97h	See Table 3-10 for register mapping details
C18h	—	C98h	—	D18h	—	D98h	—	E18h		E98h		F18h		F98h	
C19h	—	C99h	—	D19h	—	D99h	—	E19h		E99h		F19h		F99h	
C1Ah	—	C9Ah	—	D1Ah	—	D9Ah	—	E1Ah		E9Ah		F1Ah		F9Ah	
C1Bh	—	C9Bh	—	D1Bh	—	D9Bh	—	E1Bh		E9Bh		F1Bh		F9Bh	
C1Ch	—	C9Ch	—	D1Ch	—	D9Ch	—	E1Ch		E9Ch		F1Ch		F9Ch	
C1Dh	—	C9Dh	—	D1Dh	—	D9Dh	—	E1Dh		E9Dh		F1Dh		F9Dh	
C1Eh	—	C9Eh	—	D1Eh	—	D9Eh	—	E1Eh		E9Eh		F1Eh		F9Eh	
C1Fh	—	C9Fh	—	D1Fh	—	D9Fh	—	E1Fh		E9Fh		F1Fh		F9Fh	
C20h	—	CA0h	—	D20h	—	DA0h	—	E20h		EA0h		F20h		FA0h	
	Unimplemented Read as '0'		Unimplemented Read as '0'		Unimplemented Read as '0'		Unimplemented Read as '0'								
C6Fh	Accesses 70h – 7Fh	CEFh	Accesses 70h – 7Fh	D6Fh	Accesses 70h – 7Fh	DEFh	Accesses 70h – 7Fh	E6Fh	Accesses 70h – 7Fh	EEFh	Accesses 70h – 7Fh	F6Fh	Accesses 70h – 7Fh	FEFh	Accesses 70h – 7Fh
C70h		CF0h		D70h		DF0h		E70h		EF0h		F70h		FF0h	
CFh		CFh		D7Fh		DFh		E7Fh		EFh		F7Fh		FFh	

Legend:  = Unimplemented data memory locations, read as '0'.

TABLE 3-8: PIC16(L)F1718/9 MEMORY MAP, BANK 24-31

BANK 24		BANK 25		BANK 26		BANK 27		BANK 28		BANK 29		BANK 30		BANK 31				
C00h	Core Registers (Table 3-2)	C80h	Core Registers (Table 3-2)	D00h	Core Registers (Table 3-2)	D80h	Core Registers (Table 3-2)	E00h	Core Registers (Table 3-2)	E80h	Core Registers (Table 3-2)	F00h	Core Registers (Table 3-2)	F80h	Core Registers (Table 3-2)			
C0Bh	—	C8Bh	—	D0Bh	—	D8Bh	—	E0Bh	—	E8Bh	—	F0Bh	—	F8Bh	—			
C0Ch	—	C8Ch	—	D0Ch	—	D8Ch	—	E0Ch	—	E8Ch	—	F0Ch	—	F8Ch	—			
C0Dh	—	C8Dh	—	D0Dh	—	D8Dh	—	E0Dh	—	E8Dh	—	F0Dh	—	F8Dh	—			
C0Eh	—	C8Eh	—	D0Eh	—	D8Eh	—	E0Eh	—	E8Eh	—	F0Eh	—	F8Eh	—			
C0Fh	—	C8Fh	—	D0Fh	—	D8Fh	—	E0Fh	—	E8Fh	—	F0Fh	—	F8Fh	—			
C10h	—	C90h	—	D10h	—	D90h	—	E10h	—	E90h	—	F10h	—	F90h	—			
C11h	—	C91h	—	D11h	—	D91h	—	E11h	—	E91h	—	F11h	—	F91h	—			
C12h	—	C92h	—	D12h	—	D92h	—	E12h	—	E92h	—	F12h	—	F92h	—			
C13h	—	C93h	—	D13h	—	D93h	—	E13h	—	E93h	—	F13h	—	F93h	—			
C14h	—	C94h	—	D14h	—	D94h	—	E14h	—	E94h	—	F14h	—	F94h	—			
C15h	—	C95h	—	D15h	—	D95h	—	E15h	—	E95h	—	F15h	—	F95h	—			
C16h	—	C96h	—	D16h	—	D96h	—	E16h	—	E96h	—	F16h	—	F96h	—			
C17h	—	C97h	—	D17h	—	D97h	—	E17h	—	E97h	—	F17h	—	F97h	—			
C18h	—	C98h	—	D18h	—	D98h	—	E18h	—	E98h	—	F18h	—	F98h	—			
C19h	—	C99h	—	D19h	—	D99h	—	E19h	—	E99h	—	F19h	—	F99h	—			
C1Ah	—	C9Ah	—	D1Ah	—	D9Ah	—	E1Ah	—	E9Ah	—	F1Ah	—	F9Ah	—			
C1Bh	—	C9Bh	—	D1Bh	—	D9Bh	—	E1Bh	—	E9Bh	—	F1Bh	—	F9Bh	—			
C1Ch	—	C9Ch	—	D1Ch	—	D9Ch	—	E1Ch	—	E9Ch	—	F1Ch	—	F9Ch	—			
C1Dh	—	C9Dh	—	D1Dh	—	D9Dh	—	E1Dh	—	E9Dh	—	F1Dh	—	F9Dh	—			
C1Eh	—	C9Eh	—	D1Eh	—	D9Eh	—	E1Eh	—	E9Eh	—	F1Eh	—	F9Eh	—			
C1Fh	—	C9Fh	—	D1Fh	—	D9Fh	—	E1Fh	—	E9Fh	—	F1Fh	—	F9Fh	—			
C20h	General Purpose Register 80 Bytes	CA0h	General Purpose Register 32 Bytes	D20h	Unimplemented Read as '0'	DA0h	Unimplemented Read as '0'	E20h	See Table 3-9 for register mapping details	EA0h	See Table 3-9 for register mapping details	F20h	See Table 3-9 for register mapping details	FA0h	See Table 3-10 for register mapping details			
		CBFh																
		CC0h	Unimplemented Read as '0'															
C6Fh	Accesses 70h – 7Fh	CEFh	Accesses 70h – 7Fh	D6Fh	Accesses 70h – 7Fh	DEFh	Accesses 70h – 7Fh	E6Fh	Accesses 70h – 7Fh	EEFh	Accesses 70h – 7Fh	F6Fh	Accesses 70h – 7Fh	FEFh	Accesses 70h – 7Fh			
C70h		CF0h		D70h		DF0h		E70h		EF0h		F70h		FF0h				
CFFh	—	CFh	—	D7Fh	—	DFh	—	E7Fh	—	EFh	—	F7Fh	—	FFh	—			

Legend: ■ = Unimplemented data memory locations, read as '0'.

# PIC16(L)F1717/8/9

**TABLE 3-9: PIC16(L)F1717/8/9 MEMORY MAP, BANK 28-30**

Bank 28		Bank 29		Bank 30	
E0Ch	—	E8Ch	—	F0Ch	—
E0Dh	—	E8Dh	—	F0Dh	—
E0Eh	—	E8Eh	—	F0Eh	—
E0Fh	PPSLOCK	E8Fh	—	F0Fh	CLCDATA
E10h	INTPPS	E90h	RA0PPS	F10h	CLC1CON
E11h	T0CKIPPS	E91h	RA1PPS	F11h	CLC1POL
E12h	T1CKIPPS	E92h	RA2PPS	F12h	CLC1SEL0
E13h	T1GPPS	E93h	RA3PPS	F13h	CLC1SEL1
E14h	CCP1PPS	E94h	RA4PPS	F14h	CLC1SEL2
E15h	CCP2PPS	E95h	RA5PPS	F15h	CLC1SEL3
E16h	—	E96h	RA6PPS	F16h	CLC1GLS0
E17h	COGINPPS	E97h	RA7PPS	F17h	CLC1GLS1
E18h	—	E98h	RB0PPS	F18h	CLC1GLS2
E19h	—	E99h	RB1PPS	F19h	CLC1GLS3
E1Ah	—	E9Ah	RB2PPS	F1Ah	CLC2CON
E1Bh	—	E9Bh	RB3PPS	F1Bh	CLC2POL
E1Ch	—	E9Ch	RB4PPS <sup>(1)</sup>	F1Ch	CLC2SEL0
E1Dh	—	E9Dh	RB5PPS <sup>(1)</sup>	F1Dh	CLC2SEL1
E1Eh	—	E9Eh	RB6PPS <sup>(1)</sup>	F1Eh	CLC2SEL2
E1Fh	—	E9Fh	RB7PPS <sup>(1)</sup>	F1Fh	CLC2SEL3
E20h	SSPCLKPPS	EA0h	RC0PPS	F20h	CLC2GLS0
E21h	SSPDATPPS	EA1h	RC1PPS	F21h	CLC2GLS1
E22h	SSPSSPPS	EA2h	RC2PPS	F22h	CLC2GLS2
E23h	—	EA3h	RC3PPS	F23h	CLC2GLS3
E24h	RXPPS	EA4h	RC4PPS	F24h	CLC3CON
E25h	CKPPS	EA5h	RC5PPS	F25h	CLC3POL
E26h	—	EA6h	RC6PPS	F26h	CLC3SEL0
E27h	—	EA7h	RC7PPS	F27h	CLC3SEL1
E28h	CLCIN0PPS	EA8h	RD0PPS <sup>(1)</sup>	F28h	CLC3SEL2
E29h	CLCIN1PPS	EA9h	RD1PPS <sup>(1)</sup>	F29h	CLC3SEL3
E2Ah	CLCIN2PPS	EAAh	RD2PPS <sup>(1)</sup>	F2Ah	CLC3GLS0
E2Bh	CLCIN3PPS	EABh	RD3PPS <sup>(1)</sup>	F2Bh	CLC3GLS1
E2Ch	—	EACH	RD4PPS <sup>(1)</sup>	F2Ch	CLC3GLS2
E2Dh	—	EADh	RD5PPS <sup>(1)</sup>	F2Dh	CLC3GLS3
E2Eh	—	EAEh	RD6PPS <sup>(1)</sup>	F2Eh	CLC4CON
E2Fh	—	EAFh	RD7PPS <sup>(1)</sup>	F2Fh	CLC4POL
E30h	—	EB0h	RE0PPS <sup>(1)</sup>	F30h	CLC4SEL0
E31h	—	EB1h	RE1PPS <sup>(1)</sup>	F31h	CLC4SEL1
E32h	—	EB2h	RE2PPS <sup>(1)</sup>	F32h	CLC4SEL2
E33h	—	EB3h	—	F33h	CLC4SEL3
E34h	—	EB4h	—	F34h	CLC4GLS0
E35h	—	EB5h	—	F35h	CLC4GLS1
E36h	—	EB6h	—	F36h	CLC4GLS2
E37h	—	EB7h	—	F37h	CLC4GLS3
E38h	—	EB8h	—	F38h	—
E39h	—	EB9h	—	F39h	—
E3Ah	—	EBAh	—	F3Ah	—
E3Bh	—	EBBh	—	F3Bh	—
E3Ch	—	EBCh	—	F3Ch	—
E3Dh	—	EBDh	—	F3Dh	—
E3Eh	—	EBEh	—	F3Eh	—
E3Fh	—	EBFh	—	F3Fh	—
E40h	—	EC0h	—	F40h	—
E6Fh	—	EEFh	—	F6Fh	—

Legend:  = Unimplemented data memory locations, read as '0',

**Note 1:** Only available on PIC16(L)F1717/9 devices.

**TABLE 3-10: PIC16(L)F1717/8/9 MEMORY MAP, BANK 31**

Bank 31	
F8Ch	
FE3h	
FE4h	STATUS_SHAD
FE5h	WREG_SHAD
FE6h	BSR_SHAD
FE7h	PCLATH_SHAD
FE8h	FSR0L_SHAD
FE9h	FSR0H_SHAD
FEAh	FSR1L_SHAD
FEBh	FSR1H_SHAD
FECCh	—
FEDh	STKPTR
FEEh	TOSL
FEFh	TOSH
FF0h	—
FFFh	

Legend:  = Unimplemented data memory locations, read as '0'.

# PIC16(L)F1717/8/9

## 3.4.5 CORE FUNCTION REGISTERS SUMMARY

The Core Function registers listed in [Table 3-11](#) can be addressed from any Bank.

**TABLE 3-11: CORE FUNCTION REGISTERS SUMMARY (1)**

Addr.	Name	Bit 7	Bit 6	Bit 5	Bit 4	Bit 3	Bit 2	Bit 1	Bit 0	Value on POR, BOR	Value on all other Resets	
<b>Bank 0-31</b>												
x00h or x80h	INDF0	Addressing this location uses contents of FSR0H/FSR0L to address data memory (not a physical register)								xxxx xxxx	uuuu uuuu	
x01h or x81h	INDF1	Addressing this location uses contents of FSR1H/FSR1L to address data memory (not a physical register)								xxxx xxxx	uuuu uuuu	
x02h or x82h	PCL	Program Counter (PC) Least Significant Byte								0000 0000	0000 0000	
x03h or x83h	STATUS	—	—	—	$\overline{TO}$	$\overline{PD}$	Z	DC	C	---1 1000	---q quuu	
x04h or x84h	FSR0L	Indirect Data Memory Address 0 Low Pointer								0000 0000	uuuu uuuu	
x05h or x85h	FSR0H	Indirect Data Memory Address 0 High Pointer								0000 0000	0000 0000	
x06h or x86h	FSR1L	Indirect Data Memory Address 1 Low Pointer								0000 0000	uuuu uuuu	
x07h or x87h	FSR1H	Indirect Data Memory Address 1 High Pointer								0000 0000	0000 0000	
x08h or x88h	BSR	—	—	—	BSR4	BSR3	BSR2	BSR1	BSR0	---0 0000	---0 0000	
x09h or x89h	WREG	Working Register								0000 0000	uuuu uuuu	
x0Ah or x8Ah	PCLATH	—	Write Buffer for the upper 7 bits of the Program Counter								-000 0000	-000 0000
x0Bh or x8Bh	INTCON	GIE	PEIE	TMR0IE	INTE	IOCFIE	TMR0IF	INTF	IOCFIF	0000 0000	0000 0000	

**Legend:** x = unknown, u = unchanged, q = value depends on condition, - = unimplemented, read as '0', r = reserved.  
Shaded locations are unimplemented, read as '0'.

**Note 1:** These registers can be addressed from any bank.

# PIC16(L)F1717/8/9

**TABLE 3-12: SPECIAL FUNCTION REGISTER SUMMARY**

Addr.	Name	Bit 7	Bit 6	Bit 5	Bit 4	Bit 3	Bit 2	Bit 1	Bit 0	Value on POR, BOR	Value on all other Resets
<b>Bank 0</b>											
00Ch	PORTA	RA7	RA6	RA5	RA4	RA3	RA2	RA1	RA0	xxxx xxxx	uuuu uuuu
00Dh	PORTB	RB7	RB6	RB5	RB4	RB3	RB2	RB1	RB0	xxxx xxxx	uuuu uuuu
00Eh	PORTC	RC7	RC6	RC5	RC4	RC3	RC2	RC1	RC0	xxxx xxxx	uuuu uuuu
00Fh	PORTD <sup>(1)</sup>	RD7	RD6	RD5	RD4	RD3	RD2	RD1	RD0	xxxx xxxx	uuuu uuuu
010h	PORTE	—	—	—	—	RE3	RE2 <sup>(1)</sup>	RE1 <sup>(1)</sup>	RE0 <sup>(1)</sup>	---- xxxx	---- uuuu
011h	PIR1	TMR1GIF	ADIF	RCIF	TXIF	SSP1IF	CCP1IF	TMR2IF	TMR1IF	0000 0000	0000 0-00
012h	PIR2	OSFIF	C2IF	C1IF	—	BCL1IF	TMR6IF	TMR4IF	CCP2IF	000- 0000	000- 00--
013h	PIR3	—	NCOIF	COGIF	ZCDIF	CLC4IF	CLC3IF	CLC2IF	CLC1IF	-000 0000	--00 -000
014h	—	Unimplemented								—	—
015h	TMR0	Timer0 Module Register								xxxx xxxx	uuuu uuuu
016h	TMR1L	Holding Register for the Least Significant Byte of the 16-bit TMR1 Register								xxxx xxxx	uuuu uuuu
017h	TMR1H	Holding Register for the Most Significant Byte of the 16-bit TMR1 Register								xxxx xxxx	uuuu uuuu
018h	T1CON	TMR1CS<1:0>		T1CKPS<1:0>		T1OSCEN	T1SYNC	—	TMR1ON	0000 00-0	uuuu uu-u
019h	T1GCON	TMR1GE	T1GPOL	T1GTM	T1GSPM	T1GGO/DONE	T1GVAL	T1GSS<1:0>		0000 0x00	uuuu uxuu
01Ah	TMR2	Holding Register for the 8-bit TMR2 Register								0000 0000	uuuu uuuu
01Bh	PR2	Timer2 Period Register								1111 1111	uuuu uuuu
01Ch	T2CON	—	T2OUTPS<3:0>				TMR2ON	T2CKPS<1:0>		-000 0000	-000 0000
01Dh to 01Fh	—	Unimplemented								—	—
<b>Bank 1</b>											
08Ch	TRISA	TRISA7	TRISA6	TRISA5	TRISA4	TRISA3	TRISA2	TRISA1	TRISA0	1111 1111	1111 1111
08Dh	TRISB	TRISB7	TRISB6	TRISB5	TRISB4	TRISB3	TRISB2	TRISB1	TRISA0	1111 1111	1111 1111
08Eh	TRISC	TRISC7	TRISC6	TRISC5	TRISC4	TRISC3	TRISC2	TRISC1	TRISC0	1111 1111	1111 1111
08Fh	TRISD <sup>(1)</sup>	TRISD7	TRISD6	TRISD5	TRISD4	TRISD3	TRISD2	TRISD1	TRISD0	1111 1111	1111 1111
090h	TRISE	—	—	—	—	TRISE3	TRISE2 <sup>(1)</sup>	TRISE1 <sup>(1)</sup>	TRISE0 <sup>(1)</sup>	---- 1111	---- 1111
091h	PIE1	TMR1GIE	ADIE	RCIE	TXIE	SSP1IE	CCP1IE	TMR2IE	TMR1IE	0000 0000	0000 0000
092h	PIE2	OSFIE	C2IE	C1IE	—	BCL1IE	TMR6IE	TMR4IE	CCP2IE	000- 0000	000- 0000
093h	PIE3	—	NCOIE	COGIE	ZCDIE	CLC4IE	CLC3IE	CLC2IE	CLC1IE	-000 0000	--00 -000
094h	—	Unimplemented								—	—
095h	OPTION_REG	WPUEN	INTEDG	TMR0CS	TMR0SE	PSA	PS<2:0>		1111 1111	1111 1111	
096h	PCON	STKOVF	STKUNF	—	RWD $\bar{T}$	RMCLR	R $\bar{I}$	POR	BOR	00-1 11qq	qq-q qquu
097h	WDTCN	—	—	WDTPS<4:0>				SWDTEN	--01 0110	--01 0110	
098h	OSCTUNE	—	—	TUN<5:0>				--00 0000	--00 0000		
099h	OSCCON	SPLLEN	IRCF<3:0>			—	SCS<1:0>		0011 1-00	0011 1-00	
09Ah	OSCSTAT	SOSCR	PLL $\bar{R}$	OSTS	HFIOFR	HFIOFL	MFIOFR	LFIOFR	HFIOFS	00q0 0q0q	qqqq --0q
09Bh	ADRESL	ADC Result Register Low								xxxx xxxx	uuuu uuuu
09Ch	ADRESH	ADC Result Register High								xxxx xxxx	uuuu uuuu
09Dh	ADCON0	—	CHS<4:0>				GO/DONE	ADON	-000 0000	-000 0000	
09Eh	ADCON1	ADFM	ADCS<2:0>		—	ADNREF	ADPREF<1:0>		0000 -000	0000 --00	
09Fh	ADCON2	TRIGSEL<3:0>			—	—	—	—	0000 ----	0000 ----	

**Legend:** x = unknown, u = unchanged, q = value depends on condition, - = unimplemented, read as '0', r = reserved.  
Shaded locations are unimplemented, read as '0'.

**Note 1:** Unimplemented on PIC16(L)F1718.  
**Note 2:** Unimplemented on PIC16LF1717/8/9

# PIC16(L)F1717/8/9

**TABLE 3-12: SPECIAL FUNCTION REGISTER SUMMARY (CONTINUED)**

Addr.	Name	Bit 7	Bit 6	Bit 5	Bit 4	Bit 3	Bit 2	Bit 1	Bit 0	Value on POR, BOR	Value on all other Resets		
<b>Bank 2</b>													
10Ch	LATA	—	—	LATA5	LATA4	—	LATA2	LATA1	LATA0	xxxx xxxx	uuuu uuuu		
10Dh	LATB	LATB7	LATB6	LATB5	LATB4	LATB3	LATB2	LATB1	LATB0	xxxx xxxx	uuuu uuuu		
10Eh	LATC	LATC7	LATC6	LATC5	LATC4	LATC3	LATC2	LATC1	LATC0	xxxx xxxx	uuuu uuuu		
10Fh	LATD <sup>(1)</sup>	LATD7	LATD6	LATD5	LATD4	LATD3	LATD2	LATD1	LATD0	xxxx xxxx	uuuu uuuu		
110h	LATE <sup>(1)</sup>	—	—	—	—	—	LATE2	LATE1	LATE0	---- -xxx	---- -uuu		
111h	CM1CON0	C1ON	C1OUT	—	C1POL	C1ZLF	C1SP	C1HYS	C1SYNC	00-0 0100	00-0 0100		
112h	CM1CON1	C1INTP	C1INTN	C1PCH<2:0>			C1NCH<2:0>			0000 0000	0000 0000		
113h	CM2CON0	C2ON	C2OUT	—	C2POL	C2ZLF	C2SP	C2HYS	C2SYNC	00-0 0100	00-0 0100		
114h	CM2CON1	C2INTP	C2INTN	C2PCH<2:0>			C2NCH<2:0>			0000 0000	0000 0000		
115h	CMOUT	—	—	—	—	—	—	MC2OUT	MC1OUT	---- --00	---- --00		
116h	BORCON	SBOREN	BORFS	—	—	—	—	—	BORRDY	10-- ---q	uu-- ---u		
117h	FVRCON	FVREN	FVRRDY	TSEN	TSRNG	CDAFVR<1:0>		ADFVR<1:0>		0q00 0000	0q00 0000		
118h	DAC1CON0	DAC1EN	—	DAC1OE1	DAC1OE2	DAC1PSS<1:0>		—	DAC1NSS	0-00 00-0	0-00 00-0		
119h	DAC1CON1	DAC1R<7:0>								0000 0000	0000 0000		
11Ah	DAC2CON0	DAC2EN	—	DAC2OE1	DAC2OE2	DAC2PSS<1:0>		—	DAC2NSS	0-00 00-0	0-00 00-0		
11Bh	DAC2CON1	—	—	—	DAC2R<4:0>					---0 0000	---0 0000		
11Ch	ZCD1CON	ZCD1EN	—	ZCD1OUT	ZCD1POL	—	—	ZCD1INTP	ZCD1INTN	0-x0 --00	0-00 --00		
11Dh	—	Unimplemented								—	—		
11Eh	—	Unimplemented								—	—		
11Fh	—	Unimplemented								—	—		
<b>Bank 3</b>													
18Ch	ANSELA	—	—	ANSA5	ANSA4	ANSA3	ANSA2	ANSA1	ANSA0	--11 1111	--11 1111		
18Dh	ANSELB	—	—	ANSB5	ANSB4	ANSB3	ANSB2	ANSB1	ANSB0	--11 1111	--11 1111		
18Eh	ANSELC	ANSC7	ANSC6	ANSC5	ANSC4	ANSC3	ANSC2	—	—	1111 11--	1111 11--		
18Fh	ANSELD <sup>(1)</sup>	ANSD7	ANSD6	ANSD5	ANSD4	ANSD3	ANSD2	ANSD1	ANSD0	1111 1111	1111 1111		
190h	ANSELE <sup>(1)</sup>	—	—	—	—	—	ANSE2	ANSE1	ANSE0	---- -111	---- -111		
191h	PMADRL	Program Memory Address Register Low Byte								0000 0000	0000 0000		
192h	PMADRH	—	Program Memory Address Register High Byte								1000 0000	1000 0000	
193h	PMDATL	Program Memory Read Data Register Low Byte								xxxx xxxx	uuuu uuuu		
194h	PMDATH	—	—	Program Memory Read Data Register High Byte								--xx xxxx	--uu uuuu
195h	PMCON1	—	CFGS	LWLO	FREE	WRERR	WREN	WR	RD	-000 x000	-000 q000		
196h	PMCON2	Program Memory Control Register 2								0000 0000	0000 0000		
197h	VREGCON <sup>(2)</sup>	—	—	—	—	—	—	VREGPM	Reserved	---- --01	---- --01		
198h	—	Unimplemented								—	—		
199h	RC1REG	USART Receive Data Register								0000 0000	0000 0000		
19Ah	TX1REG	USART Transmit Data Register								0000 0000	0000 0000		
19Bh	SP1BRGL	SP1BRG<7:0>								0000 0000	0000 0000		
19Ch	SP1BRGH	SP1BRG<15:8>								0000 0000	0000 0000		
19Dh	RC1STA	SPEN	RX9	SREN	CREN	ADDEN	FERR	OERR	RX9D	0000 0000	0000 0000		
19Eh	TX1STA	CSRC	TX9	TXEN	SYNC	SENDB	BRGH	TRMT	TX9D	0000 0010	0000 0010		
19Fh	BAUD1CON	ABDOVF	RCIDL	—	SCKP	BRG16	—	WUE	ABDEN	01-0 0-00	01-0 0-00		

**Legend:** x = unknown, u = unchanged, q = value depends on condition, - = unimplemented, read as '0', r = reserved.  
Shaded locations are unimplemented, read as '0'.

- Note** 1: Unimplemented on PIC16(L)F1718.  
2: Unimplemented on PIC16LF1717/8/9



# PIC16(L)F1717/8/9

**TABLE 3-12: SPECIAL FUNCTION REGISTER SUMMARY (CONTINUED)**

Addr.	Name	Bit 7	Bit 6	Bit 5	Bit 4	Bit 3	Bit 2	Bit 1	Bit 0	Value on POR, BOR	Value on all other Resets
<b>Bank 4</b>											
20Ch	WPUA	WPUA7	WPUA6	WPUA5	WPUA4	WPUA3	WPUA2	WPUA1	WPUA0	1111 1111	1111 1111
20Dh	WPUB	WPUB7	WPUB6	WPUB5	WPUB4	WPUB3	WPUB2	WPUB1	WPUB0	1111 1111	1111 1111
20Eh	WPUC	WPUC7	WPUC6	WPUC5	WPUC4	WPUC3	WPUC2	WPUC1	WPUC0	1111 1111	1111 1111
20Fh	WPUD <sup>(1)</sup>	WPUD7	WPUD6	WPUD5	WPUD4	WPUD3	WPUD2	WPUD1	WPUD0	1111 1111	1111 1111
210h	WPUE	—	—	—	—	WPUE3	WPUE2 <sup>(1)</sup>	WPUE1 <sup>(1)</sup>	WPUE0 <sup>(1)</sup>	---- 1111	---- 1111
211h	SSP1BUF	Synchronous Serial Port Receive Buffer/Transmit Register								XXXX XXXX	uuuu uuuu
212h	SSP1ADD	ADD<7:0>								XXXX XXXX	0000 0000
213h	SSP1MSK	MSK<7:0>								XXXX XXXX	1111 1111
214h	SSP1STAT	SMP	CKE	D $\bar{A}$	P	S	R $\bar{W}$	UA	BF	0000 0000	0000 0000
215h	SSP1CON1	WCOL	SSPOV	SSPEN	CKP	SSPM<3:0>				0000 0000	0000 0000
216h	SSP1CON2	GCEN	ACKSTAT	ACKDT	ACKEN	RCEN	PEN	RSEN	SEN	0000 0000	0000 0000
217h	SSP1CON3	ACKTIM	PCIE	SCIE	BOEN	SDAHT	SBCDE	AHEN	DHEN	0000 0000	0000 0000
218h — 21Fh	—	Unimplemented								—	—
<b>Bank 5</b>											
28Ch	ODCONA	ODA7	ODA6	ODA5	ODA4	ODA3	ODA2	ODA1	ODA0	0000 0000	0000 0000
28Dh	ODCONB	ODB7	ODB6	ODB5	ODB4	ODB3	ODB2	ODB1	ODB0	0000 0000	0000 0000
28Eh	ODCONC	ODC7	ODC6	ODC5	ODC4	ODC3	ODC2	ODC1	ODC0	0000 0000	0000 0000
28Fh	ODCOND <sup>(1)</sup>	ODD7	ODD6	ODD5	ODD4	ODD3	ODD2	ODD1	ODD0	0000 0000	0000 0000
290h	ODCONE <sup>(1)</sup>	—	—	—	—	—	ODE2	ODE1	ODE0	---- -000	---- -000
291h	CCPR1L	Capture/Compare/PWM Register 1 (LSB)								xxxx xxxx	uuuu uuuu
292h	CCPR1H	Capture/Compare/PWM Register 1 (MSB)								xxxx xxxx	uuuu uuuu
293h	CCP1CON	—	—	DC1B<1:0>			CCP1M<3:0>			--00 0000	--00 0000
294h — 297h	—	Unimplemented								—	—
298h	CCPR2L	Capture/Compare/PWM Register 2 (LSB)								xxxx xxxx	uuuu uuuu
299h	CCPR2H	Capture/Compare/PWM Register 2 (MSB)								xxxx xxxx	uuuu uuuu
29Ah	CCP2CON	—	—	DC2B<1:0>			CCP2M<3:0>			--00 0000	--00 0000
29Bh — 29Dh	—	Unimplemented								—	—
29Eh	CCPTMRS	P4TSEL<1:0>		P3TSEL<1:0>		C2TSEL<1:0>		C1TSEL<1:0>		0000 0000	0000 0000
29Fh	—	Unimplemented								—	—
<b>Bank 6</b>											
30Ch	SLRCONA	SLRA7	SLRA6	SLRA5	SLRA4	SLRA3	SLRA2	SLRA1	SLRA0	1111 1111	0000 0000
30Dh	SLRCONB	SLRB7	SLRB6	SLRB5	SLRB4	SLRB3	SLRB2	SLRB1	SLRB0	1111 1111	0000 0000
30Eh	SLRCONC	SLRC7	SLRC6	SLRC5	SLRC4	SLRC3	SLRC2	SLRC1	SLRC0	1111 1111	0000 0000
30Fh	SLRCOND <sup>(1)</sup>	SLRD7	SLRD6	SLRD5	SLRD4	SLRD3	SLRD2	SLRD1	SLRD0	1111 1111	0000 0000
310h	SLRCONE <sup>(1)</sup>	—	—	—	—	—	SLRE2	SLRE1	SLRE0	---- -111	---- -000
311h — 31Fh	—	Unimplemented								—	—

**Legend:** x = unknown, u = unchanged, q = value depends on condition, - = unimplemented, read as '0', r = reserved.  
Shaded locations are unimplemented, read as '0'.

**Note 1:** Unimplemented on PIC16(L)F1718.  
**Note 2:** Unimplemented on PIC16LF1717/8/9

# PIC16(L)F1717/8/9

**TABLE 3-12: SPECIAL FUNCTION REGISTER SUMMARY (CONTINUED)**

Addr.	Name	Bit 7	Bit 6	Bit 5	Bit 4	Bit 3	Bit 2	Bit 1	Bit 0	Value on POR, BOR	Value on all other Resets	
<b>Bank 7</b>												
38Ch	INLVLA	INLVLA7	INLVLA6	INLVLA5	INLVLA4	INLVLA3	INLVLA2	INLVLA1	INLVLA0	1111 1111	1111 1111	
38Dh	INVLVB	INVLVB7	INVLVB6	INVLVB5	INVLVB4	INVLVB3	INVLVB2	INVLVB1	INVLVB0	1111 1111	1111 1111	
38Eh	INLVLC	INLVLC7	INLVLC6	INLVLC5	INLVLC4	INLVLC3	INLVLC2	INLVLC1	INLVLC0	1111 1111	1111 1111	
38Fh	INLVLD <sup>(1)</sup>	INLVLD7	INLVLD6	INLVLD5	INLVLD4	INLVLD3	INLVLD2	INLVLD1	INLVLD0	1111 1111	1111 1111	
390h	INLVLE					INLVLE3	INLVLE2 <sup>(1)</sup>	INLVLE1 <sup>(1)</sup>	INLVLE0 <sup>(1)</sup>	---- 1111	---- 1111	
391h	IOCAP	IOCAP7	IOCAP6	IOCAP5	IOCAP4	IOCAP3	IOCAP2	IOCAP1	IOCAP0	0000 0000	--00 0000	
392h	IOCAN	IOCAN7	IOCAN6	IOCAN5	IOCAN4	IOCAN3	IOCAN2	IOCAN1	IOCAN0	0000 0000	--00 0000	
393h	IOCAF	IOCAF7	IOCAF6	IOCAF5	IOCAF4	IOCAF3	IOCAF2	IOCAF1	IOCAF0	0000 0000	--00 0000	
394h	IOCBP	IOCBP7	IOCBP6	IOCBP5	IOCBP4	IOCBP3	IOCBP2	IOCBP1	IOCBP0	0000 0000	0000 ----	
395h	IOCBN	IOCBN7	IOCBN6	IOCBN5	IOCBN4	IOCBN3	IOCBN2	IOCBN1	IOCBN0	0000 0000	0000 ----	
396h	IOCBF	IOCBF7	IOCBF6	IOCBF5	IOCBF4	IOCBF3	IOCBF2	IOCBF1	IOCBF0	0000 0000	0000 ----	
397h	IOCCP	IOCCP7	IOCCP6	IOCCP5	IOCCP4	IOCCP3	IOCCP2	IOCCP1	IOCCP0	0000 0000	0000 0000	
398h	IOCCN	IOCCN7	IOCCN6	IOCCN5	IOCCN4	IOCCN3	IOCCN2	IOCCN1	IOCCN0	0000 0000	0000 0000	
399h	IOCCF	IOCCF7	IOCCF6	IOCCF5	IOCCF4	IOCCF3	IOCCF2	IOCCF1	IOCCF0	0000 0000	0000 0000	
39Ah — 39Ch	—	Unimplemented								—	—	
39Dh	IOCEP	—	—	—	—	IOCEP3	—	—	—	---- 0---	---- 0---	
39Eh	IOCEN	—	—	—	—	IOCEN3	—	—	—	---- 0---	---- 0---	
39Fh	IOCEF	—	—	—	—	IOCEF3	—	—	—	---- 0---	---- 0---	
<b>Bank 8</b>												
40Ch — 414h	—	Unimplemented								—	—	
415h	TMR4	Holding Register for the 8-bit TMR4 Register								0000 0000	uuuu uuuu	
416h	PR4	Timer4 Period Register								1111 1111	uuuu uuuu	
417h	T4CON	—	T4OUTPS<3:0>				TMR4ON	T4CKPS<1:0>			-000 0000	-000 0000
418h — 41Bh	—	Unimplemented								—	—	
41Ch	TMR6	Holding Register for the 8-bit TMR6 Register								0000 0000	uuuu uuuu	
41Dh	PR6	Timer6 Period Register								1111 1111	uuuu uuuu	
41Eh	T6CON	—	T6OUTPS<3:0>				TMR6ON	T6CKPS<1:0>			-000 0000	-000 0000
41Fh	—	Unimplemented								—	—	
<b>Bank 9</b>												
48Ch to 497h	—	Unimplemented								—	—	
498h	NCO1ACCL	NCO1ACC								0000 0000	0000 0000	
499h	NCO1ACCH	NCO1ACC								0000 0000	0000 0000	
49Ah	NCO1ACCU	NCO1ACC								---- 0000	---- 0000	
49Bh	NCO1INCL	NCO1INC								0000 0001	0000 0001	
49Ch	NCO1INCH	NCO1INC								0000 0000	0000 0000	
49Dh	NCO1INCU	NCO1INC								---- 0000	---- 0000	
49Eh	NCO1CON	N1EN	—	N1OUT	N1POL	—	—	—	N1PFM	0-00 ---0	0-00 ---0	
49Fh	NCO1CLK	N1PWS<2:0>				—	—	—	N1CKS<1:0>		000- --00	000- --00

**Legend:** x = unknown, u = unchanged, c = value depends on condition, - = unimplemented, read as '0', r = reserved.  
Shaded locations are unimplemented, read as '0'.

- Note** 1: Unimplemented on PIC16(L)F1718.  
2: Unimplemented on PIC16LF1717/8/9

# PIC16(L)F1717/8/9

**TABLE 3-12: SPECIAL FUNCTION REGISTER SUMMARY (CONTINUED)**

Addr.	Name	Bit 7	Bit 6	Bit 5	Bit 4	Bit 3	Bit 2	Bit 1	Bit 0	Value on POR, BOR	Value on all other Resets
<b>Bank 10</b>											
50Ch — 510h	—	Unimplemented								—	—
511h	OPA1CON	OPA1EN	OPA1SP	—	OPA1UG	—	—	OPA1PCH<1:0>		00-0 --00	00-0 --00
512h — 514h	—	Unimplemented								—	—
515h	OPA2CON	OPA2EN	OPA2SP	—	OPA2UG	—	—	OPA2PCH<1:0>		00-0 --00	00-0 --00
516h — 51Fh	—	Unimplemented								—	—
<b>Bank 11</b>											
58Ch to 59Fh	—	Unimplemented								—	—
<b>Bank 12</b>											
60Ch to 616h	—	Unimplemented								—	—
617h	PWM3DCL	PWM3DC<1:0>		—	—	—	—	—	—	xx-- ----	uu-- ----
618h	PWM3DCH	PWM3DCH<7:0>								xxxx xxxx	uuuu uuuu
619h	PWM3CON	PWM3EN	—	PWM3OUT	PWM3POL	—	—	—	—	0-x0 ----	u-uu ----
61Ah	PWM4DCL	PWM4DCL<1:0>		—	—	—	—	—	—	xx-- ----	uu-- ----
61Bh	PWM4DCH	PWM4DCH<7:0>								xxxx xxxx	uuuu uuuu
61Ch	PWM4CON	PWM4EN	—	PWM4OUT	PWM4POL	—	—	—	—	0-x0 ----	u-uu ----
61Dh — 61Fh	—	Unimplemented								—	—
<b>Bank 13</b>											
68Ch to 690h	—	Unimplemented								—	—
691h	COG1PHR	—	—	COG Rising Edge Phase Delay Count Register						--xx xxxx	--uu uuuu
692h	COG1PHF	—	—	COG Falling Edge Phase Delay Count Register						--xx xxxx	--uu uuuu
693h	COG1BLKR	—	—	COG Rising Edge Blanking Count Register						--xx xxxx	--uu uuuu
694h	COG1BLKF	—	—	COG Falling Edge Blanking Count Register						--xx xxxx	--uu uuuu
695h	COG1DBR	—	—	COG Rising Edge Dead-band Count Register						--xx xxxx	--uu uuuu
696h	COG1DBF	—	—	COG Falling Edge Dead-band Count Register						--xx xxxx	--uu uuuu
697h	COG1CON0	G1EN	G1LD	—	G1CS<1:0>		G1MD<2:0>			00-0 0000	00-0 0000
698h	COG1CON1	G1RDBS	G1FDBS	—	—	G1POLD	G1POLC	G1POLB	G1POLA	00-- 0000	00-- 0000
699h	COG1RIS	G1RIS7	G1RIS6	G1RIS5	G1RIS4	G1RIS3	G1RIS2	G1RIS1	G1RIS0	0000 0000	-000 0000
69Ah	COG1RSIM	G1RSIM7	G1RSIM6	G1RSIM5	G1RSIM4	G1RSIM3	G1RSIM2	G1RSIM1	G1RSIM0	0000 0000	-000 0000
69Bh	COG1FIS	G1FIS7	G1FIS6	G1FIS5	G1FIS4	G1FIS3	G1FIS2	G1FIS1	G1FIS0	0000 0000	-000 0000
69Ch	COG1FSIM	G1FSIM7	G1FSIM6	G1FSIM5	G1FSIM4	G1FSIM3	G1FSIM2	G1FSIM1	G1FSIM0	0000 0000	-000 0000
69Dh	COG1ASD0	G1ASE	G1ARSEN	G1ASDBD<1:0>		G1ASDAC<1:0>		—	—	0001 01--	0001 01--
69Eh	COG1ASD1	—	—	—	—	G1AS3E	G1AS2E	G1AS1E	G1AS0E	---- 0000	---- 0000
69Fh	COG1STR	G1SDATD	G1SDATC	G1SDATB	G1SDATA	G1STRD	G1STRC	G1STRB	G1STRA	0000 0001	0000 0001

**Legend:** x = unknown, u = unchanged, q = value depends on condition, - = unimplemented, read as '0', r = reserved.  
Shaded locations are unimplemented, read as '0'.

- Note** 1: Unimplemented on PIC16(L)F1718.  
2: Unimplemented on PIC16LF1717/8/9

# PIC16(L)F1717/8/9

**TABLE 3-12: SPECIAL FUNCTION REGISTER SUMMARY (CONTINUED)**

Addr.	Name	Bit 7	Bit 6	Bit 5	Bit 4	Bit 3	Bit 2	Bit 1	Bit 0	Value on POR, BOR	Value on all other Resets
<b>Bank 14-27</b>											
x0Ch/ x8Ch — x1Fh/ x9Fh	—	Unimplemented								—	—
<b>Bank 28</b>											
E0Ch — E0Eh	—	Unimplemented								—	—
E0Fh	PPSLOCK	—	—	—	—	—	—	—	PPSLOCKED	---- --0	---- --0
E10h	INTPPS	—	—	—	INTPPS<4:0>					---0 1000	---u uuuu
E11h	T0CKIPPS	—	—	—	T0CKIPPS<4:0>					---0 0100	---u uuuu
E12h	T1CKIPPS	—	—	—	T1CKIPPS<4:0>					---1 0000	---u uuuu
E13h	T1GPPS	—	—	—	T1GPPS<4:0>					---0 1101	---u uuuu
E14h	CCP1PPS	—	—	—	CCP1PPS<4:0>					---1 0010	---u uuuu
E15h	CCP2PPS	—	—	—	CCP2PPS<4:0>					---1 0001	---u uuuu
E16h	—	Unimplemented								—	—
E17h	COGINPPS	—	—	—	COGINPPS<4:0>					---0 1000	---u uuuu
E18h	—	Unimplemented								—	—
E19h	—	Unimplemented								—	—
E1Ah — E1Fh	—	Unimplemented								—	—
E20h	SSPCLKPPS	—	—	—	SSPCLKPPS<4:0>					---1 0011	---u uuuu
E21h	SSPDATPPS	—	—	—	SSPDATPPS<4:0>					---1 0100	---u uuuu
E22h	SSPSSPPS	—	—	—	SSPSSPPS<4:0>					---0 0101	---u uuuu
E23h	—	Unimplemented								—	—
E24h	RXPPS	—	—	—	RXPPS<4:0>					---1 0111	---u uuuu
E25h	CKPPS	—	—	—	CKPPS<4:0>					---1 0110	---u uuuu
E26h	—	Unimplemented								—	—
E27h	—	Unimplemented								—	—
E28h	CLCIN0PPS	—	—	—	CLCIN0PPS<4:0>					---0 0000	---u uuuu
E29h	CLCIN1PPS	—	—	—	CLCIN1PPS<4:0>					---0 0001	---u uuuu
E2Ah	CLCIN2PPS	—	—	—	CLCIN2PPS<4:0>					---0 1110	---u uuuu
E2Bh	CLCIN3PPS	—	—	—	CLCIN3PPS<4:0>					---0 1111	---u uuuu
E2Ch to E6Fh	—	Unimplemented								—	—

**Legend:** x = unknown, u = unchanged, q = value depends on condition, - = unimplemented, read as '0', r = reserved.  
Shaded locations are unimplemented, read as '0'.

- Note** 1: Unimplemented on PIC16(L)F1718.  
2: Unimplemented on PIC16LF1717/8/9

# PIC16(L)F1717/8/9

**TABLE 3-12: SPECIAL FUNCTION REGISTER SUMMARY (CONTINUED)**

Addr.	Name	Bit 7	Bit 6	Bit 5	Bit 4	Bit 3	Bit 2	Bit 1	Bit 0	Value on POR, BOR	Value on all other Resets
<b>Bank 29</b>											
E8Ch — E8Fh	—	Unimplemented								—	—
E90h	RA0PPS	—	—	—	—	—	RA0PPS<4:0>	—	—	---0 0000	---u uuuu
E91h	RA1PPS	—	—	—	—	—	RA1PPS<4:0>	—	—	---0 0000	---u uuuu
E92h	RA2PPS	—	—	—	—	—	RA2PPS<4:0>	—	—	---0 0000	---u uuuu
E93h	RA3PPS	—	—	—	—	—	RA3PPS<4:0>	—	—	---0 0000	---u uuuu
E94h	RA4PPS	—	—	—	—	—	RA4PPS<4:0>	—	—	---0 0000	---u uuuu
E95h	RA5PPS	—	—	—	—	—	RA5PPS<4:0>	—	—	---0 0000	---u uuuu
E96h	RA6PPS	—	—	—	—	—	RA6PPS<4:0>	—	—	---0 0000	---u uuuu
E97h	RA7PPS	—	—	—	—	—	RA7PPS<4:0>	—	—	---0 0000	---u uuuu
E98h	RB0PPS	—	—	—	—	—	RB0PPS<4:0>	—	—	---0 0000	---u uuuu
E99h	RB1PPS	—	—	—	—	—	RB1PPS<4:0>	—	—	---0 0000	---u uuuu
E9Ah	RB2PPS	—	—	—	—	—	RB2PPS<4:0>	—	—	---0 0000	---u uuuu
E9Bh	RB3PPS	—	—	—	—	—	RB3PPS<4:0>	—	—	---0 0000	---u uuuu
E9Ch	RB4PPS	—	—	—	—	—	RB4PPS<4:0>	—	—	---0 0000	---u uuuu
E9Dh	RB5PPS	—	—	—	—	—	RB5PPS<4:0>	—	—	---0 0000	---u uuuu
E9Eh	RB6PPS	—	—	—	—	—	RB6PPS<4:0>	—	—	---0 0000	---u uuuu
E9Fh	RB7PPS	—	—	—	—	—	RB7PPS<4:0>	—	—	---0 0000	---u uuuu
EA0h	RC0PPS	—	—	—	—	—	RC0PPS<4:0>	—	—	---0 0000	---u uuuu
EA1h	RC1PPS	—	—	—	—	—	RC1PPS<4:0>	—	—	---0 0000	---u uuuu
EA2h	RC2PPS	—	—	—	—	—	RC2PPS<4:0>	—	—	---0 0000	---u uuuu
EA3h	RC3PPS	—	—	—	—	—	RC3PPS<4:0>	—	—	---0 0000	---u uuuu
EA4h	RC4PPS	—	—	—	—	—	RC4PPS<4:0>	—	—	---0 0000	---u uuuu
EA5h	RC5PPS	—	—	—	—	—	RC5PPS<4:0>	—	—	---0 0000	---u uuuu
EA6h	RC6PPS	—	—	—	—	—	RC6PPS<4:0>	—	—	---0 0000	---u uuuu
EA7h	RC7PPS	—	—	—	—	—	RC7PPS<4:0>	—	—	---0 0000	---u uuuu
EA8h	RD0PPS <sup>(1)</sup>	—	—	—	—	—	RD0PPS<4:0>	—	—	---0 0000	---u uuuu
EA9h	RD1PPS <sup>(1)</sup>	—	—	—	—	—	RD1PPS<4:0>	—	—	---0 0000	---u uuuu
EAAh	RD2PPS <sup>(1)</sup>	—	—	—	—	—	RD2PPS<4:0>	—	—	---0 0000	---u uuuu
EABh	RD3PPS <sup>(1)</sup>	—	—	—	—	—	RD3PPS<4:0>	—	—	---0 0000	---u uuuu
EACh	RD4PPS <sup>(1)</sup>	—	—	—	—	—	RD4PPS<4:0>	—	—	---0 0000	---u uuuu
EADh	RD5PPS <sup>(1)</sup>	—	—	—	—	—	RD5PPS<4:0>	—	—	---0 0000	---u uuuu
EAEh	RD6PPS <sup>(1)</sup>	—	—	—	—	—	RD6PPS<4:0>	—	—	---0 0000	---u uuuu
EAFh	RD7PPS <sup>(1)</sup>	—	—	—	—	—	RD7PPS<4:0>	—	—	---0 0000	---u uuuu
EB0h	RE0PPS <sup>(1)</sup>	—	—	—	—	—	RE0PPS<4:0>	—	—	---0 0000	---u uuuu
EB1h	RE1PPS <sup>(1)</sup>	—	—	—	—	—	RE1PPS<4:0>	—	—	---0 0000	---u uuuu
EB2h	RE2PPS <sup>(1)</sup>	—	—	—	—	—	RE2PPS<4:0>	—	—	---0 0000	---u uuuu
EB3h — EEFh	—	Unimplemented								—	—

**Legend:** x = unknown, u = unchanged, q = value depends on condition, - = unimplemented, read as '0', r = reserved.  
Shaded locations are unimplemented, read as '0'.

- Note** 1: Unimplemented on PIC16(L)F1718.  
2: Unimplemented on PIC16LF1717/8/9

# PIC16(L)F1717/8/9

**TABLE 3-12: SPECIAL FUNCTION REGISTER SUMMARY (CONTINUED)**

Addr.	Name	Bit 7	Bit 6	Bit 5	Bit 4	Bit 3	Bit 2	Bit 1	Bit 0	Value on POR, BOR	Value on all other Resets
<b>Bank 30</b>											
F0Ch — F0Eh	—	Unimplemented								—	—
F0Fh	CLCDATA	—	—	—	—	MLC4OUT	MLC3OUT	MLC2OUT	MLC1OUT	---- 0000	---- 0000
F10h	CLC1CON	LC1EN	—	LC1OUT	LC1INTP	LC1INTN	LC1MODE<2:0>			0-x0 0000	0-00 0000
F11h	CLC1POL	LC1POL	—	—	—	LC1G4POL	LC1G3POL	LC1G2POL	LC1G1POL	x--- xxxx	0--- uuuu
F12h	CLC1SEL0	—	—	—	LC1D1S<4:0>					---x xxxx	---u uuuu
F13h	CLC1SEL1	—	—	—	LC1D2S<4:0>					---x xxxx	---u uuuu
F14h	CLC1SEL2	—	—	—	LC1D3S<4:0>					---x xxxx	---u uuuu
F15h	CLC1SEL3	—	—	—	LC1D4S<4:0>					---x xxxx	---u uuuu
F16h	CLC1GLS0	LC1G1D4T	LC1G1D4N	LC1G1D3T	LC1G1D3N	LC1G1D2T	LC1G1D2N	LC1G1D1T	LC1G1D1N	xxxx xxxx	uuuu uuuu
F17h	CLC1GLS1	LC1G2D4T	LC1G2D4N	LC1G2D3T	LC1G2D3N	LC1G2D2T	LC1G2D2N	LC1G2D1T	LC1G2D1N	xxxx xxxx	uuuu uuuu
F18h	CLC1GLS2	LC1G3D4T	LC1G3D4N	LC1G3D3T	LC1G3D3N	LC1G3D2T	LC1G3D2N	LC1G3D1T	LC1G3D1N	xxxx xxxx	uuuu uuuu
F19h	CLC1GLS3	LC1G4D4T	LC1G4D4N	LC1G4D3T	LC1G4D3N	LC1G4D2T	LC1G4D2N	LC1G4D1T	LC1G4D1N	xxxx xxxx	uuuu uuuu
F1Ah	CLC2CON	LC2EN	—	LC2OUT	LC2INTP	LC2INTN	LC2MODE<2:0>			0-x0 0000	0-00 0000
F1Bh	CLC2POL	LC2POL	—	—	—	LC2G4POL	LC2G3POL	LC2G2POL	LC2G1POL	x--- xxxx	0--- uuuu
F1Ch	CLC2SEL0	—	—	—	LC2D1S<4:0>					---x xxxx	---u uuuu
F1Dh	CLC2SEL1	—	—	—	LC2D2S<4:0>					---x xxxx	---u uuuu
F1Eh	CLC2SEL2	—	—	—	LC2D3S<4:0>					---x xxxx	---u uuuu
F1Fh	CLC2SEL3	—	—	—	LC2D4S<4:0>					---x xxxx	---u uuuu
F20h	CLC2GLS0	LC2G1D4T	LC2G1D4N	LC2G1D3T	LC2G1D3N	LC2G1D2T	LC2G1D2N	LC2G1D1T	LC2G1D1N	xxxx xxxx	uuuu uuuu
F21h	CLC2GLS1	LC2G2D4T	LC2G2D4N	LC2G2D3T	LC2G2D3N	LC2G2D2T	LC2G2D2N	LC2G2D1T	LC2G2D1N	xxxx xxxx	uuuu uuuu
F22h	CLC2GLS2	LC2G3D4T	LC2G3D4N	LC2G3D3T	LC2G3D3N	LC2G3D2T	LC2G3D2N	LC2G3D1T	LC2G3D1N	xxxx xxxx	uuuu uuuu
F23h	CLC2GLS3	LC2G4D4T	LC2G4D4N	LC2G4D3T	LC2G4D3N	LC2G4D2T	LC2G4D2N	LC2G4D1T	LC2G4D1N	xxxx xxxx	uuuu uuuu
F24h	CLC3CON	LC3EN	—	LC3OUT	LC3INTP	LC3INTN	LC3MODE<2:0>			0-x0 0000	0-00 0000
F25h	CLC3POL	LC3POL	—	—	—	LC3G4POL	LC3G3POL	LC3G2POL	LC3G1POL	x--- xxxx	0--- uuuu
F26h	CLC3SEL0	—	—	—	LC3D1S<4:0>					---x xxxx	---u uuuu
F27h	CLC3SEL1	—	—	—	LC3D2S<4:0>					---x xxxx	---u uuuu
F28h	CLC3SEL2	—	—	—	LC3D3S<4:0>					---x xxxx	---u uuuu
F29h	CLC3SEL3	—	—	—	LC3D4S<4:0>					---x xxxx	---u uuuu
F2Ah	CLC3GLS0	LC3G1D4T	LC3G1D4N	LC3G1D3T	LC3G1D3N	LC3G1D2T	LC3G1D2N	LC3G1D1T	LC3G1D1N	xxxx xxxx	uuuu uuuu
F2Bh	CLC3GLS1	LC3G2D4T	LC3G2D4N	LC3G2D3T	LC3G2D3N	LC3G2D2T	LC3G2D2N	LC3G2D1T	LC3G2D1N	xxxx xxxx	uuuu uuuu
F2Ch	CLC3GLS2	LC3G3D4T	LC3G3D4N	LC3G3D3T	LC3G3D3N	LC3G3D2T	LC3G3D2N	LC3G3D1T	LC3G3D1N	xxxx xxxx	uuuu uuuu
F2Dh	CLC3GLS3	LC3G4D4T	LC3G4D4N	LC3G4D3T	LC3G4D3N	LC3G4D2T	LC3G4D2N	LC3G4D1T	LC3G4D1N	xxxx xxxx	uuuu uuuu
F2Eh	CLC4CON	LC4EN	—	LC4OUT	LC4INTP	LC4INTN	LC4MODE<2:0>			0-x0 0000	0-00 0000
F2Fh	CLC4POL	LC4POL	—	—	—	LC4G4POL	LC4G3POL	LC4G2POL	LC4G1POL	x--- xxxx	0--- uuuu
F30h	CLC4SEL0	—	—	—	LC4D1S<4:0>					---x xxxx	---u uuuu
F31h	CLC4SEL1	—	—	—	LC4D2S<4:0>					---x xxxx	---u uuuu
F32h	CLC4SEL2	—	—	—	LC4D3S<4:0>					---x xxxx	---u uuuu
F33h	CLC4SEL3	—	—	—	LC4D4S<4:0>					---x xxxx	---u uuuu
F34h	CLC4GLS0	LC4G1D4T	LC4G1D4N	LC4G1D3T	LC4G1D3N	LC4G1D2T	LC4G1D2N	LC4G1D1T	LC4G1D1N	xxxx xxxx	uuuu uuuu
F35h	CLC4GLS1	LC4G2D4T	LC4G2D4N	LC4G2D3T	LC4G2D3N	LC4G2D2T	LC4G2D2N	LC4G2D1T	LC4G2D1N	xxxx xxxx	uuuu uuuu
F36h	CLC4GLS2	LC4G3D4T	LC4G3D4N	LC4G3D3T	LC4G3D3N	LC4G3D2T	LC4G3D2N	LC4G3D1T	LC4G3D1N	xxxx xxxx	uuuu uuuu
F37h	CLC4GLS3	LC4G4D4T	LC4G4D4N	LC4G4D3T	LC4G4D3N	LC4G4D2T	LC4G4D2N	LC4G4D1T	LC4G4D1N	xxxx xxxx	uuuu uuuu
F38h — F6Fh	—	Unimplemented								—	—

**Legend:** x = unknown, u = unchanged, q = value depends on condition, - = unimplemented, read as '0', r = reserved.  
Shaded locations are unimplemented, read as '0'.

- Note** 1: Unimplemented on PIC16(L)F1718.  
2: Unimplemented on PIC16LF1717/8/9

# PIC16(L)F1717/8/9

**TABLE 3-12: SPECIAL FUNCTION REGISTER SUMMARY (CONTINUED)**

Addr.	Name	Bit 7	Bit 6	Bit 5	Bit 4	Bit 3	Bit 2	Bit 1	Bit 0	Value on POR, BOR	Value on all other Resets	
<b>Bank 31</b>												
F8Ch — FE3h	—	Unimplemented								—	—	
FE4h	STATUS_SHAD	—	—	—	—	—	Z_SHAD	DC_SHAD	C_SHAD	---- -xxx	---- -uuu	
FE5h	WREG_SHAD	WREG_SHAD								xxxx xxxx	uuuu uuuu	
FE6h	BSR_SHAD	—	—	—	BSR_SHAD					---x xxxx	---u uuuu	
FE7h	PCLATH_SHAD	—	PCLATH_SHAD								-xxx xxxx	-uuu uuuu
FE8h	FSR0L_SHAD	FSR0L_SHAD								xxxx xxxx	uuuu uuuu	
FE9h	FSR0H_SHAD	FSR0H_SHAD								xxxx xxxx	uuuu uuuu	
FEAh	FSR1L_SHAD	FSR1L_SHAD								xxxx xxxx	uuuu uuuu	
FEBh	FSR1H_SHAD	FSR1H_SHAD								xxxx xxxx	uuuu uuuu	
FECh	—	Unimplemented								—	—	
FEDh	STKPTR	—	—	—	STKPTR					---1 1111	---1 1111	
FEEh	TOSL	TOSL								xxxx xxxx	uuuu uuuu	
FEFh	TOSH	—	TOSH								-xxx xxxx	-uuu uuuu

**Legend:** x = unknown, u = unchanged, q = value depends on condition, - = unimplemented, read as '0', r = reserved.  
Shaded locations are unimplemented, read as '0'.

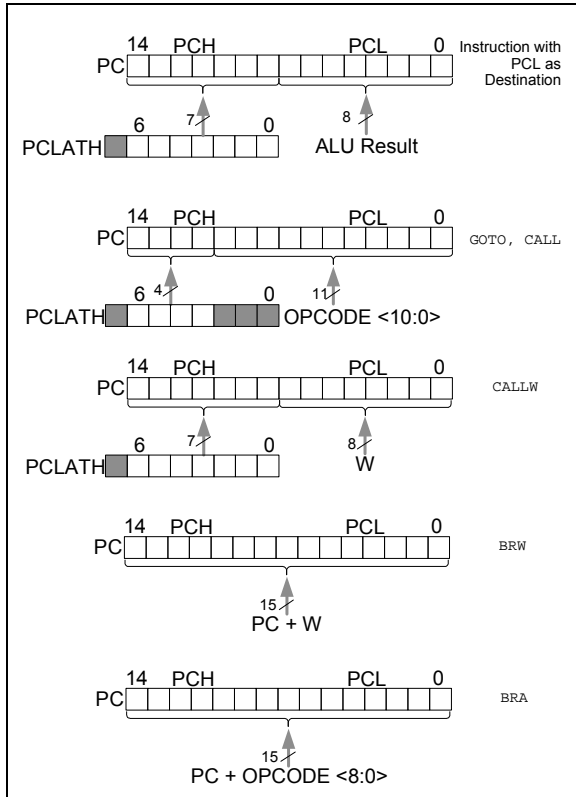
- Note** 1: Unimplemented on PIC16(L)F1718.  
2: Unimplemented on PIC16LF1717/8/9

# PIC16(L)F1717/8/9

## 3.5 PCL and PCLATH

The Program Counter (PC) is 15 bits wide. The low byte comes from the PCL register, which is a readable and writable register. The high byte (PC<14:8>) is not directly readable or writable and comes from PCLATH. On any Reset, the PC is cleared. Figure 3-4 shows the five situations for the loading of the PC.

**FIGURE 3-4: LOADING OF PC IN DIFFERENT SITUATIONS**



### 3.5.1 MODIFYING PCL

Executing any instruction with the PCL register as the destination simultaneously causes the Program Counter PC<14:8> bits (PCH) to be replaced by the contents of the PCLATH register. This allows the entire contents of the program counter to be changed by writing the desired upper seven bits to the PCLATH register. When the lower eight bits are written to the PCL register, all 15 bits of the program counter will change to the values contained in the PCLATH register and those being written to the PCL register.

### 3.5.2 COMPUTED GOTO

A computed GOTO is accomplished by adding an offset to the program counter ( $ADDWF\ PCL$ ). When performing a table read using a computed GOTO method, care should be exercised if the table location crosses a PCL memory boundary (each 256-byte block). Refer to Application Note AN556, "Implementing a Table Read" (DS00556).

### 3.5.3 COMPUTED FUNCTION CALLS

A computed function CALL allows programs to maintain tables of functions and provide another way to execute state machines or look-up tables. When performing a table read using a computed function CALL, care should be exercised if the table location crosses a PCL memory boundary (each 256-byte block).

If using the CALL instruction, the PCH<2:0> and PCL registers are loaded with the operand of the CALL instruction. PCH<6:3> is loaded with PCLATH<6:3>.

The CALLW instruction enables computed calls by combining PCLATH and W to form the destination address. A computed CALLW is accomplished by loading the W register with the desired address and executing CALLW. The PCL register is loaded with the value of W and PCH is loaded with PCLATH.

### 3.5.4 BRANCHING

The branching instructions add an offset to the PC. This allows relocatable code and code that crosses page boundaries. There are two forms of branching, BRW and BRA. The PC will have incremented to fetch the next instruction in both cases. When using either branching instruction, a PCL memory boundary may be crossed.

If using BRW, load the W register with the desired unsigned address and execute BRW. The entire PC will be loaded with the address  $PC + 1 + W$ .

If using BRA, the entire PC will be loaded with  $PC + 1 +$ , the signed value of the operand of the BRA instruction.



## 3.6 Stack

All devices have a 16-level x 15-bit wide hardware stack (refer to [Figure 3-1](#)). The stack space is not part of either program or data space. The PC is PUSHed onto the stack when `CALL` or `CALLW` instructions are executed or an interrupt causes a branch. The stack is POPed in the event of a `RETURN`, `RETLW` or a `RETFIE` instruction execution. `PCLATH` is not affected by a `PUSH` or `POP` operation.

The stack operates as a circular buffer if the `STVREN` bit is programmed to '0' (Configuration Words). This means that after the stack has been PUSHed sixteen times, the seventeenth PUSH overwrites the value that was stored from the first PUSH. The eighteenth PUSH overwrites the second PUSH (and so on). The `STKOVF` and `STKUNF` flag bits will be set on an Overflow/Underflow, regardless of whether the Reset is enabled.

**Note:** There are no instructions/mnemonics called `PUSH` or `POP`. These are actions that occur from the execution of the `CALL`, `CALLW`, `RETURN`, `RETLW` and `RETFIE` instructions or the vectoring to an interrupt address.

### 3.6.1 ACCESSING THE STACK

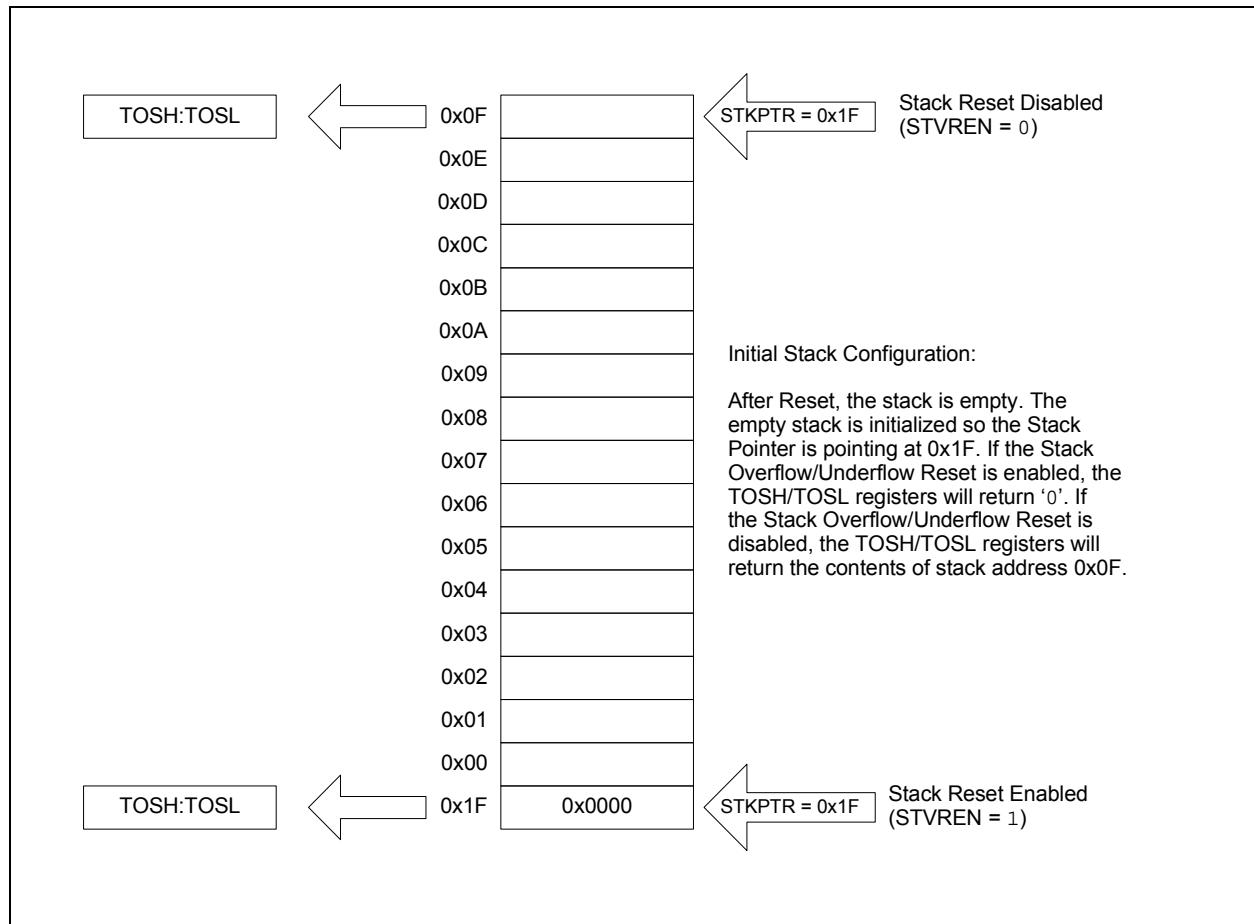
The stack is available through the `TOSH`, `TOSL` and `STKPTR` registers. `STKPTR` is the current value of the Stack Pointer. `TOSH:TOSL` register pair points to the TOP of the stack. Both registers are read/writable. `TOS` is split into `TOSH` and `TOSL` due to the 15-bit size of the PC. To access the stack, adjust the value of `STKPTR`, which will position `TOSH:TOSL`, then read/write to `TOSH:TOSL`. `STKPTR` is five bits to allow detection of overflow and underflow.

**Note:** Care should be taken when modifying the `STKPTR` while interrupts are enabled.

During normal program operation, `CALL`, `CALLW` and Interrupts will increment `STKPTR` while `RETLW`, `RETURN`, and `RETFIE` will decrement `STKPTR`. At any time, `STKPTR` can be inspected to see how much stack is left. The `STKPTR` always points at the currently used place on the stack. Therefore, a `CALL` or `CALLW` will increment the `STKPTR` and then write the PC, and a return will unload the PC and then decrement the `STKPTR`.

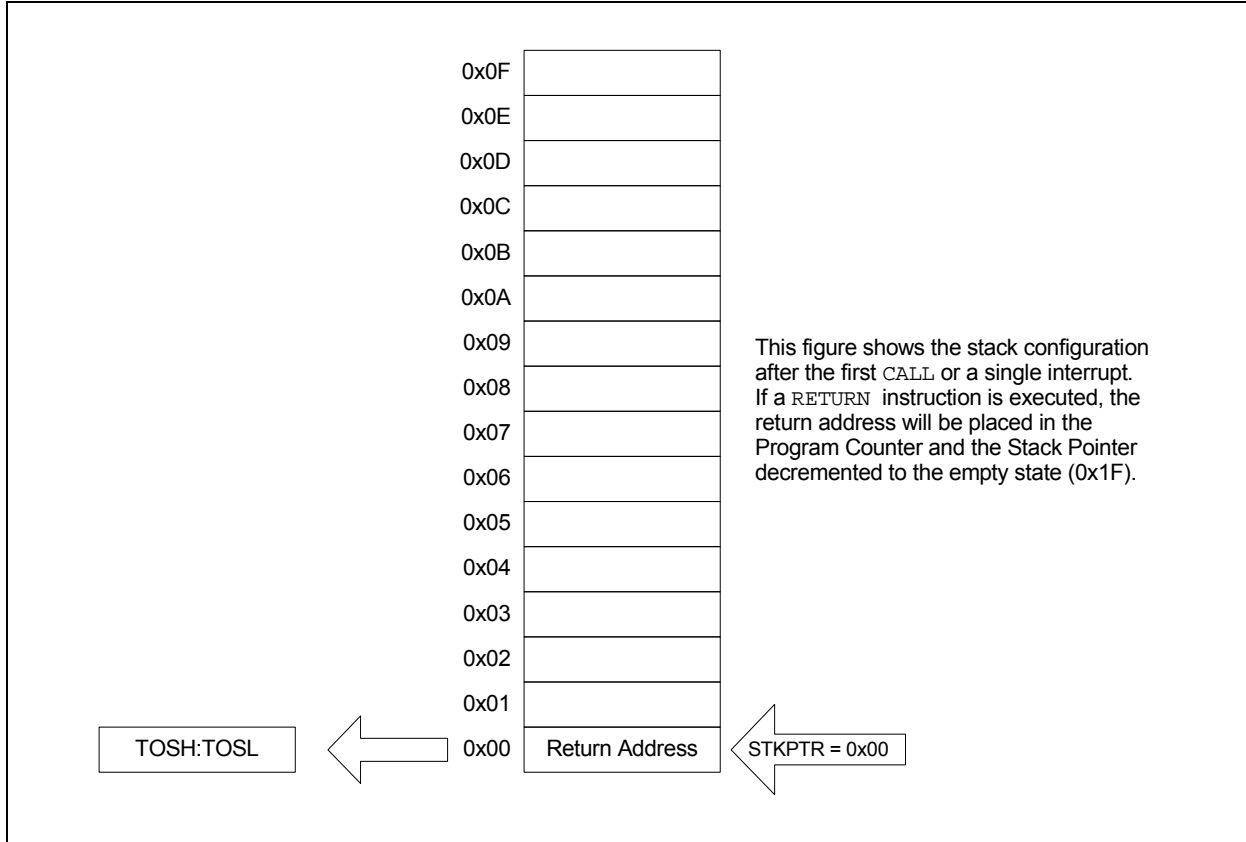
Reference [Figure 3-5](#) through [Figure 3-8](#) for examples of accessing the stack.

**FIGURE 3-5: ACCESSING THE STACK EXAMPLE 1**

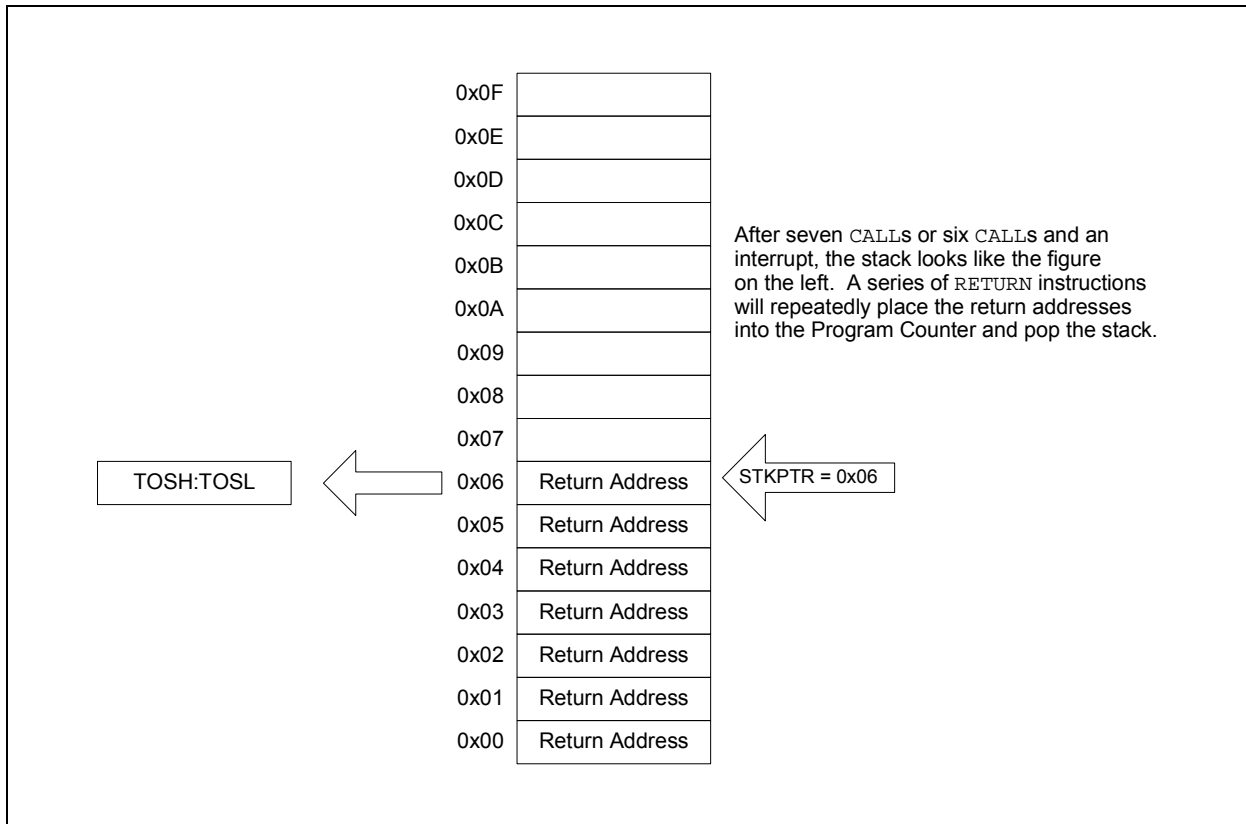


# PIC16(L)F1717/8/9

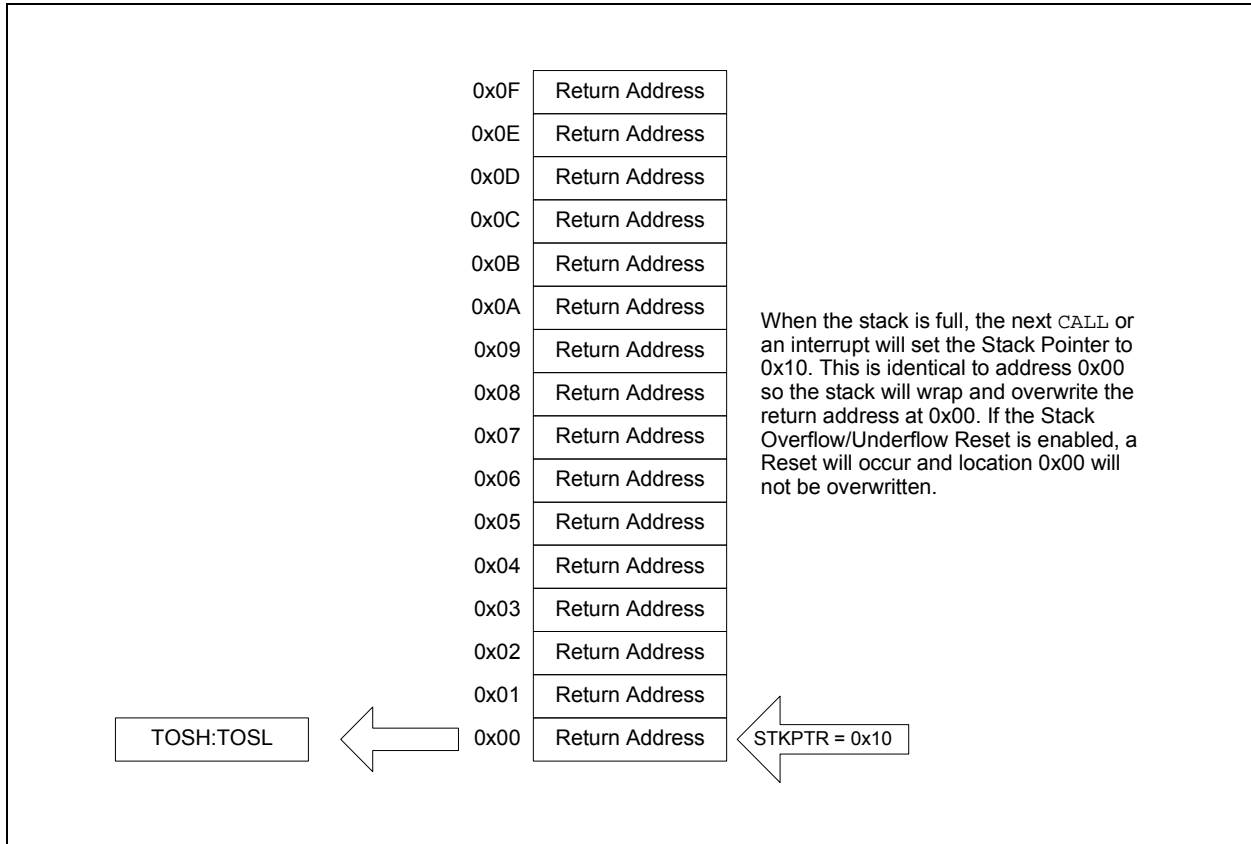
**FIGURE 3-6: ACCESSING THE STACK EXAMPLE 2**



**FIGURE 3-7: ACCESSING THE STACK EXAMPLE 3**



**FIGURE 3-8: ACCESSING THE STACK EXAMPLE 4**



### 3.6.2 OVERFLOW/UNDERFLOW RESET

If the `STVREN` bit in Configuration Words is programmed to '1', the device will be reset if the stack is PUSHed beyond the sixteenth level or POPed beyond the first level, setting the appropriate bits (`STKOVF` or `STKUNF`, respectively) in the `PCON` register.

### 3.7 Indirect Addressing

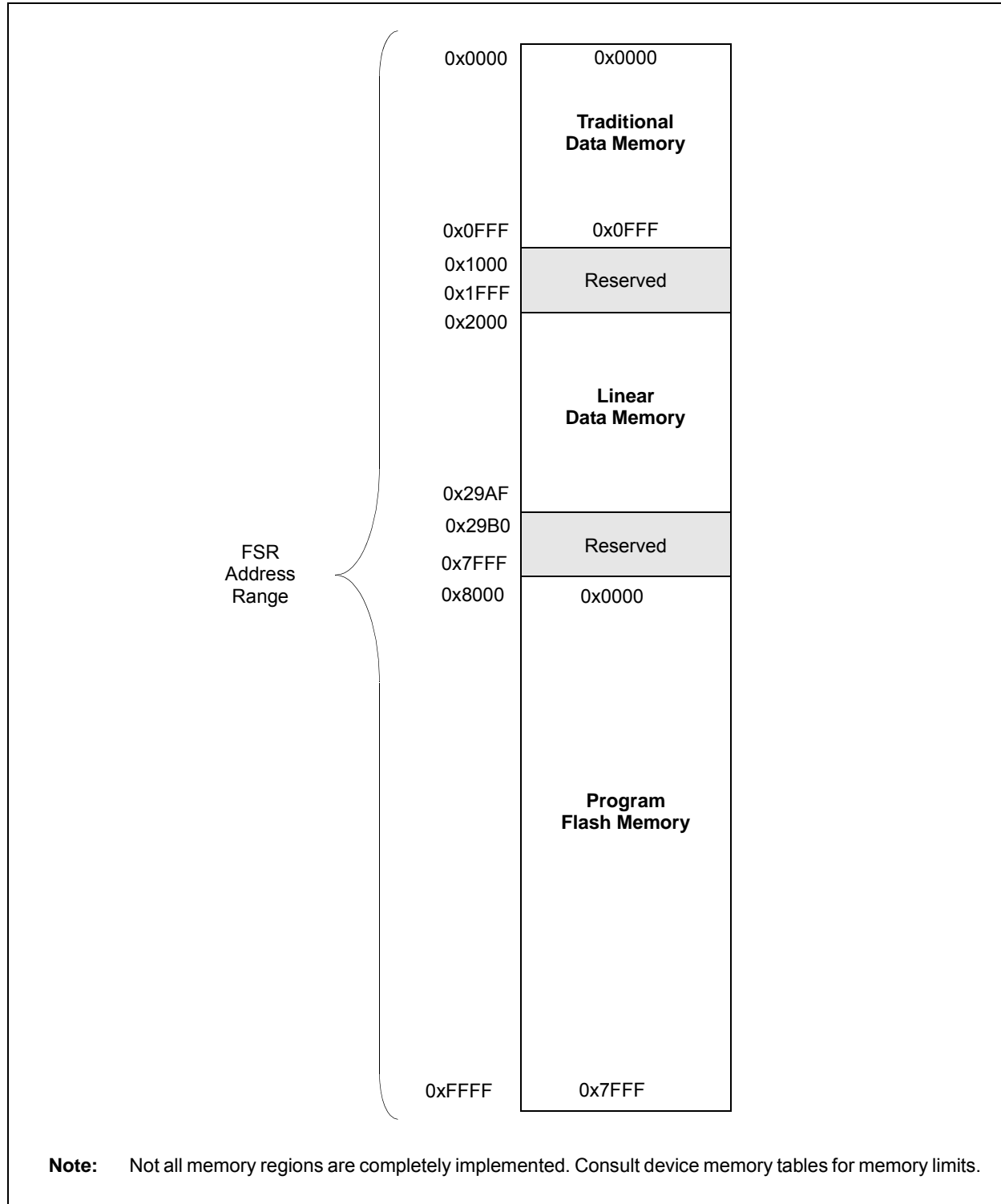
The `INDFn` registers are not physical registers. Any instruction that accesses an `INDFn` register actually accesses the register at the address specified by the File Select Registers (`FSR`). If the `FSRn` address specifies one of the two `INDFn` registers, the read will return '0' and the write will not occur (though Status bits may be affected). The `FSRn` register value is created by the pair `FSRnH` and `FSRnL`.

The `FSR` registers form a 16-bit address that allows an addressing space with 65536 locations. These locations are divided into three memory regions:

- Traditional Data Memory
- Linear Data Memory
- Program Flash Memory

# PIC16(L)F1717/8/9

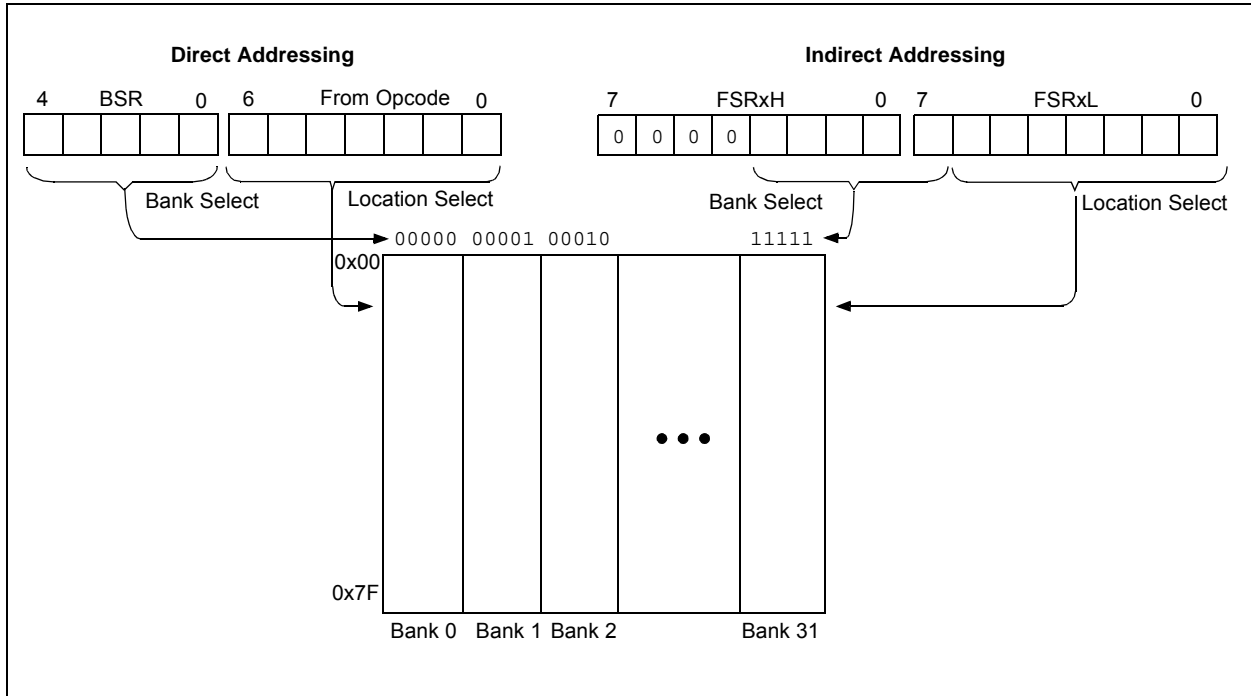
FIGURE 3-9: INDIRECT ADDRESSING



## 3.7.1 TRADITIONAL DATA MEMORY

The traditional data memory is a region from FSR address 0x000 to FSR address 0xFFF. The addresses correspond to the absolute addresses of all SFR, GPR and common registers.

**FIGURE 3-10: TRADITIONAL DATA MEMORY MAP**



# PIC16(L)F1717/8/9

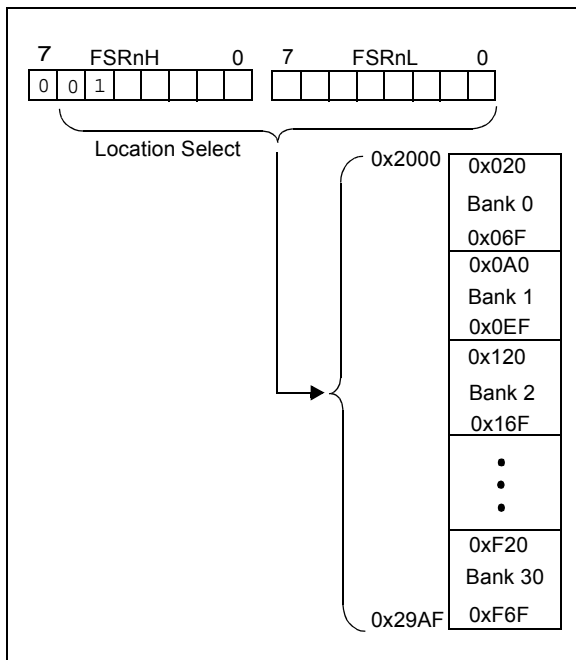
## 3.7.2 LINEAR DATA MEMORY

The linear data memory is the region from FSR address 0x2000 to FSR address 0x29AF. This region is a virtual region that points back to the 80-byte blocks of GPR memory in all the banks.

Unimplemented memory reads as 0x00. Use of the linear data memory region allows buffers to be larger than 80 bytes because incrementing the FSR beyond one bank will go directly to the GPR memory of the next bank.

The 16 bytes of common memory are not included in the linear data memory region.

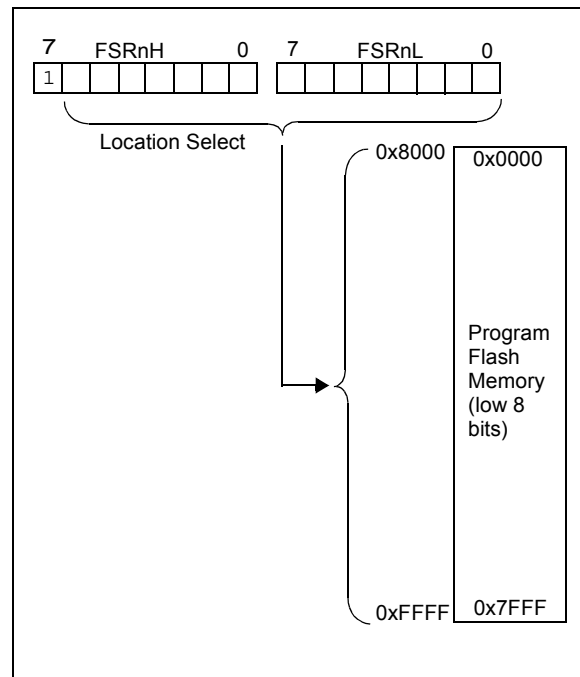
**FIGURE 3-11: LINEAR DATA MEMORY MAP**



## 3.7.3 PROGRAM FLASH MEMORY

To make constant data access easier, the entire program Flash memory is mapped to the upper half of the FSR address space. When the MSB of FSRnH is set, the lower 15 bits are the address in program memory which will be accessed through INDF. Only the lower eight bits of each memory location is accessible via INDF. Writing to the program Flash memory cannot be accomplished via the FSR/INDF interface. All instructions that access program Flash memory via the FSR/INDF interface will require one additional instruction cycle to complete.

**FIGURE 3-12: PROGRAM FLASH MEMORY MAP**



## 4.0 DEVICE CONFIGURATION

Device configuration consists of Configuration Words, Code Protection and Device ID.

### 4.1 Configuration Words

There are several Configuration Word bits that allow different oscillator and memory protection options. These are implemented as Configuration Word 1 at 8007h and Configuration Word 2 at 8008h.

**Note:** The  $\overline{\text{DEBUG}}$  bit in Configuration Words is managed automatically by device development tools including debuggers and programmers. For normal device operation, this bit should be maintained as a '1'.

### 4.2 Register Definitions: Configuration Words

**REGISTER 4-1: CONFIG1: CONFIGURATION WORD 1**

R/P-1	R/P-1	R/P-1	R/P-1	R/P-1	U-1
FCMEN	IESO	$\overline{\text{CLKOUTEN}}$	BOREN<1:0>		—
bit 13					bit 8

R/P-1	R/P-1	R/P-1	R/P-1	R/P-1	R/P-1	R/P-1	R/P-1
$\overline{\text{CP}}^{(1)}$	MCLRE	$\overline{\text{PWRTE}}$	WDTE<1:0>		FOSC<2:0>		
bit 7							bit 0

**Legend:**

R = Readable bit	P = Programmable bit	U = Unimplemented bit, read as '1'
'0' = Bit is cleared	'1' = Bit is set	-n = Value when blank or after Bulk Erase

- bit 13      **FCMEN:** Fail-Safe Clock Monitor Enable bit  
1 = Fail-Safe Clock Monitor and internal/external switchover are both enabled  
0 = Fail-Safe Clock Monitor is disabled
- bit 12      **IESO:** Internal External Switchover bit  
1 = Internal/External Switchover mode is enabled  
0 = Internal/External Switchover mode is disabled
- bit 11      **CLKOUTEN:** Clock Out Enable bit  
If FOSC Configuration bits are set to LP, XT, HS modes:  
This bit is ignored, CLKOUT function is disabled. Oscillator function on the CLKOUT pin.  
All other FOSC modes:  
1 = CLKOUT function is disabled. I/O function on the CLKOUT pin.  
0 = CLKOUT function is enabled on the CLKOUT pin
- bit 10-9    **BOREN<1:0>:** Brown-out Reset Enable bits  
11 = BOR enabled  
10 = BOR enabled during operation and disabled in Sleep  
01 = BOR controlled by SBOREN bit of the BORCON register  
00 = BOR disabled
- bit 8        **Unimplemented:** Read as '1'

# PIC16(L)F1717/8/9

---

## REGISTER 4-1: CONFIG1: CONFIGURATION WORD 1 (CONTINUED)

bit 7	<b>CP:</b> Code Protection bit <sup>(1)</sup> 1 = Program memory code protection is disabled 0 = Program memory code protection is enabled
bit 6	<b>MCLRE:</b> MCLR/VPP Pin Function Select bit <u>If LVP bit = 1:</u> This bit is ignored. <u>If LVP bit = 0:</u> 1 = MCLR/VPP pin function is MCLR; Weak pull-up enabled. 0 = MCLR/VPP pin function is digital input; MCLR internally disabled; Weak pull-up under control of WPUE3 bit.
bit 5	<b>PWRTE:</b> Power-up Timer Enable bit 1 = PWRT disabled 0 = PWRT enabled
bit 4-3	<b>WDTE&lt;1:0&gt;:</b> Watchdog Timer Enable bit 11 = WDT enabled 10 = WDT enabled while running and disabled in Sleep 01 = WDT controlled by the SWDTEN bit in the WDTCON register 00 = WDT disabled
bit 2-0	<b>FOSC&lt;2:0&gt;:</b> Oscillator Selection bits 111 = ECH: External Clock, High-Power mode (4-20 MHz): device clock supplied to CLKIN pin 110 = ECM: External Clock, Medium Power mode (0.5-4 MHz): device clock supplied to CLKIN pin 101 = ECL: External Clock, Low-Power mode (0-0.5 MHz): device clock supplied to CLKIN pin 100 = INTOSC oscillator: I/O function on CLKIN pin 011 = EXTRC oscillator: External RC circuit connected to CLKIN pin 010 = HS oscillator: High-speed crystal/resonator connected between OSC1 and OSC2 pins 001 = XT oscillator: Crystal/resonator connected between OSC1 and OSC2 pins 000 = LP oscillator: Low-power crystal connected between OSC1 and OSC2 pins

**Note 1:** The entire Flash program memory will be erased when the code protection is turned off during an erase. When a Bulk Erase Program Memory command is executed, the entire program Flash memory and configuration memory will be erased.



## REGISTER 4-2: CONFIG2: CONFIGURATION WORD 2

R/P-1	R/P-1	R/P-1	R/P-1	R/P-1	R/P-1
LVP <sup>(1)</sup>	$\overline{\text{DEBUG}}^{\text{(2)}}$	$\overline{\text{LPBOR}}$	BORV <sup>(3)</sup>	STVREN	PLLEN
bit 13					bit 8

R/P-1	U-1	U-1	U-1	U-1	R/P-1	R/P-1	R/P-1
ZCDDIS	—	—	—	—	PPS1WAY	WRT<1:0>	
bit 7						bit 0	

### Legend:

R = Readable bit

P = Programmable bit

U = Unimplemented bit, read as '1'

'0' = Bit is cleared

'1' = Bit is set

-n = Value when blank or after Bulk Erase

- bit 13      **LVP:** Low-Voltage Programming Enable bit<sup>(1)</sup>  
 1 = Low-voltage programming enabled  
 0 = High-voltage on MCLR must be used for programming
- bit 12      **DEBUG:** In-Circuit Debugger Mode bit<sup>(2)</sup>  
 1 = In-Circuit Debugger disabled, ICSPCLK and ICSPDAT are general purpose I/O pins  
 0 = In-Circuit Debugger enabled, ICSPCLK and ICSPDAT are dedicated to the debugger
- bit 11      **LPBOR:** Low-Power BOR Enable bit  
 1 = Low-Power Brown-out Reset is disabled  
 0 = Low-Power Brown-out Reset is enabled
- bit 10      **BORV:** Brown-out Reset Voltage Selection bit<sup>(3)</sup>  
 1 = Brown-out Reset voltage (**VBOR**), low trip point selected.  
 0 = Brown-out Reset voltage (**VBOR**), high trip point selected.
- bit 9        **STVREN:** Stack Overflow/Underflow Reset Enable bit  
 1 = Stack Overflow or Underflow will cause a Reset  
 0 = Stack Overflow or Underflow will not cause a Reset
- bit 8        **PLLEN:** PLL Enable bit  
 1 = 4xPLL enabled  
 0 = 4xPLL disabled
- bit 7        **ZCDDIS:** ZCD Disable bit  
 1 = ZCD disabled. ZCD can be enabled by setting the ZCDSEN bit of ZCDCON  
 0 = ZCD always enabled
- bit 6-3      **Unimplemented:** Read as '1'
- bit 2        **PPS1WAY:** PPSLOCK Bit One-Way Set Enable bit  
 1 = The PPSLOCK bit can only be set once after an unlocking sequence is executed; once PPSLOCK is set, all future changes to PPS registers are prevented  
 0 = The PPSLOCK bit can be set and cleared as needed (provided an unlocking sequence is executed)
- bit 1-0      **WRT<1:0>:** Flash Memory Self-Write Protection bits  
8 kW Flash memory (PIC16(L)F1717)  
 11 = Write protection off  
 10 = 0000h to 01FFh write-protected, 0200h to 1FFFh may be modified by PMCON control  
 01 = 0000h to 0FFFh write-protected, 1000h to 1FFFh may be modified by PMCON control  
 00 = 0000h to 1FFFh write-protected, no addresses may be modified by PMCON control  
16 kW Flash memory (PIC16(L)F1718/9)  
 11 = Write protection off  
 10 = 0000h to 01FFh write-protected, 0200h to 3FFFh may be modified by PMCON control  
 01 = 0000h to 1FFFh write-protected, 2000h to 3FFFh may be modified by PMCON control  
 00 = 0000h to 3FFFh write-protected, no addresses may be modified by PMCON control

**Note 1:** The LVP bit cannot be programmed to '0' when Programming mode is entered via LVP.

**Note 2:** The  $\overline{\text{DEBUG}}$  bit in Configuration Words is managed automatically by device development tools including debuggers and programmers. For normal device operation, this bit should be maintained as a '1'.

**Note 3:** See **VBOR** parameter for specific trip point voltages.

# PIC16(L)F1717/8/9

---

## 4.3 Code Protection

Code protection allows the device to be protected from unauthorized access. Program memory protection is controlled independently. Internal access to the program memory is unaffected by any code protection setting.

### 4.3.1 PROGRAM MEMORY PROTECTION

The entire program memory space is protected from external reads and writes by the CP bit in Configuration Words. When  $\overline{CP} = 0$ , external reads and writes of program memory are inhibited and a read will return all '0's. The CPU can continue to read program memory, regardless of the protection bit settings. Writing the program memory is dependent upon the write protection setting. See [Section 4.4 "Write Protection"](#) for more information.

## 4.4 Write Protection

Write protection allows the device to be protected from unintended self-writes. Applications, such as boot loader software, can be protected while allowing other regions of the program memory to be modified.

The WRT<1:0> bits in Configuration Words define the size of the program memory block that is protected.

## 4.5 User ID

Four memory locations (8000h-8003h) are designated as ID locations where the user can store checksum or other code identification numbers. These locations are readable and writable during normal execution. See [Section 10.4 "User ID, Device ID and Configuration Word Access"](#) for more information on accessing these memory locations. For more information on checksum calculation, see the *"PIC16(L)F170X Memory Programming Specification"* (DS41683).

## 4.6 Device ID and Revision ID

The 14-bit device ID word is located at 8006h and the 14-bit revision ID is located at 8005h. These locations are read-only and cannot be erased or modified. See [Section 10.4 "User ID, Device ID and Configuration Word Access"](#) for more information on accessing these memory locations.

Development tools, such as device programmers and debuggers, may be used to read the Device ID and Revision ID.

## 4.7 Register Definitions: Device and Revision

### REGISTER 4-3: DEVID: DEVICE ID REGISTER

R	R	R	R	R	R	R	R
DEV<13:8>							
bit 13				bit 8			

R	R	R	R	R	R	R	R
DEV<7:0>							
bit 7				bit 0			

#### Legend:

R = Readable bit

'1' = Bit is set

'0' = Bit is cleared

bit 13-0 **DEV<13:0>**: Device ID bits

Device	DEVID<13:0> Values
PIC16F1717	11 0000 0101 1100 (305Ch)
PIC16LF1717	11 0000 0101 1111 (305Fh)
PIC16F1718	11 0000 0101 1011 (305Bh)
PIC16LF1718	11 0000 0101 1110 (305Eh)
PIC16F1719	11 0000 0101 1010 (305Ah)
PIC16LF1719	11 0000 0101 1101 (305Dh)

### REGISTER 4-4: REVID: REVISION ID REGISTER

R	R	R	R	R	R	R	R
REV<13:8>							
bit 13				bit 8			

R	R	R	R	R	R	R	R
REV<7:0>							
bit 7				bit 0			

#### Legend:

R = Readable bit

'1' = Bit is set

'0' = Bit is cleared

bit 13-0 **REV<13:0>**: Revision ID bits

# PIC16(L)F1717/8/9

## 5.0 RESETS

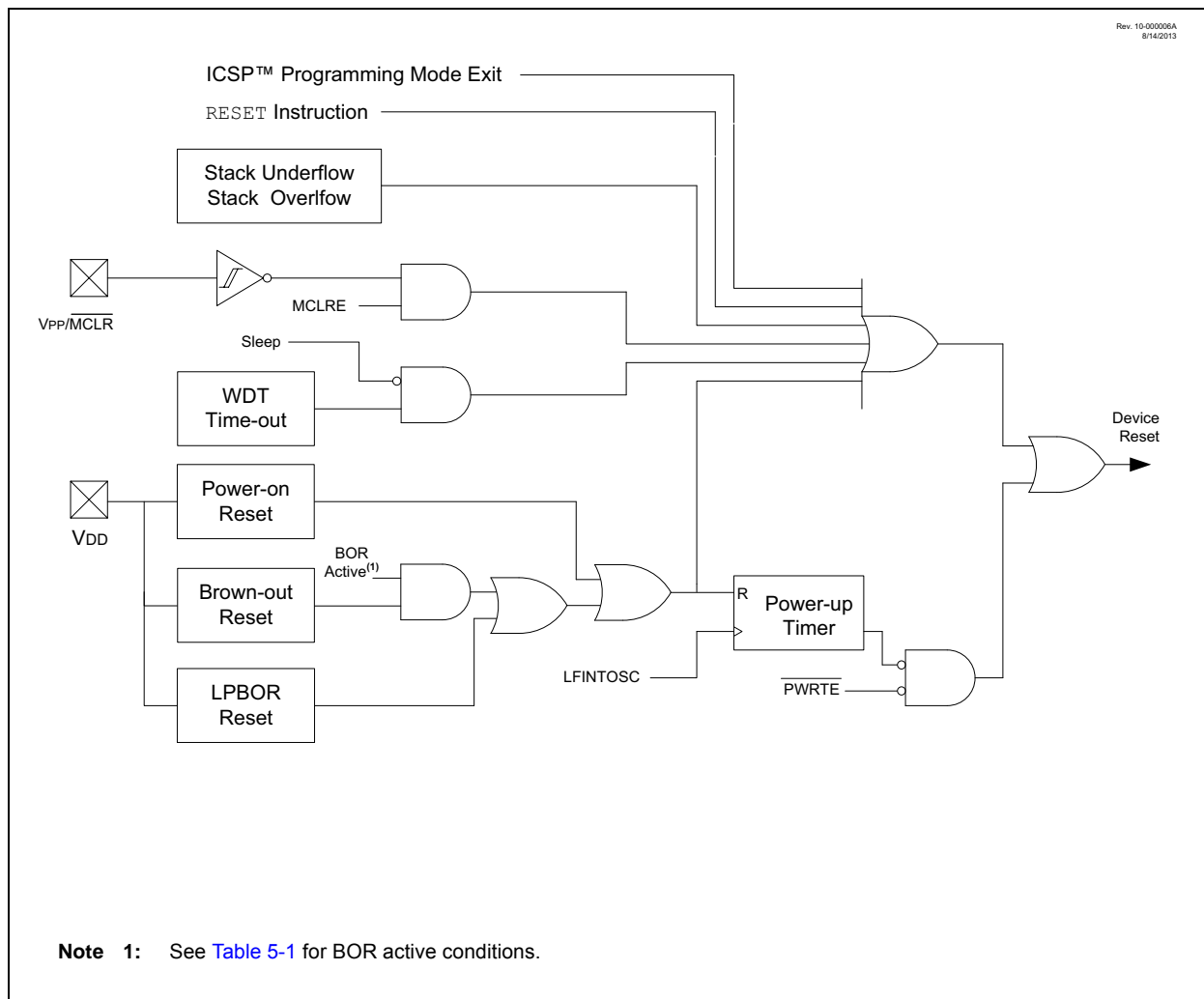
There are multiple ways to reset this device:

- Power-on Reset (POR)
- Brown-out Reset (BOR)
- Low-Power Brown-out Reset (LPBOR)
- MCLR Reset
- WDT Reset
- RESET instruction
- Stack Overflow
- Stack Underflow
- Programming mode exit

To allow VDD to stabilize, an optional Power-up Timer can be enabled to extend the Reset time after a BOR or POR event.

A simplified block diagram of the On-Chip Reset Circuit is shown in [Figure 5-1](#).

**FIGURE 5-1: SIMPLIFIED BLOCK DIAGRAM OF ON-CHIP RESET CIRCUIT**



## 5.1 Power-on Reset (POR)

The POR circuit holds the device in Reset until VDD has reached an acceptable level for minimum operation. Slow rising VDD, fast operating speeds or analog performance may require greater than minimum VDD. The PWRT, BOR or MCLR features can be used to extend the start-up period until all device operation conditions have been met.

### 5.1.1 POWER-UP TIMER (PWRT)

The Power-up Timer provides a nominal 64 ms time-out on POR or Brown-out Reset.

The device is held in Reset as long as PWRT is active. The PWRT delay allows additional time for the VDD to rise to an acceptable level. The Power-up Timer is enabled by clearing the PWRTEN bit in Configuration Words.

The Power-up Timer starts after the release of the POR and BOR.

For additional information, refer to Application Note AN607, "Power-up Trouble Shooting" (DS00607).

**TABLE 5-1: BOR OPERATING MODES**

BOREN<1:0>	SBOREN	Device Mode	BOR Mode	Instruction Execution upon: Release of POR or Wake-up from Sleep
11	X	X	Active	Waits for BOR ready <sup>(1)</sup> (BORRDY = 1)
10	X	Awake	Active	Waits for BOR ready (BORRDY = 1)
		Sleep	Disabled	
01	1	X	Active	Waits for BOR ready <sup>(1)</sup> (BORRDY = 1)
	0	X	Disabled	Begins immediately (BORRDY = x)
00	X	X	Disabled	

**Note 1:** In these specific cases, "Release of POR" and "Wake-up from Sleep", there is no delay in start-up. The BOR ready flag, (BORRDY = 1), will be set before the CPU is ready to execute instructions because the BOR circuit is forced on by the BOREN<1:0> bits.

### 5.2.1 BOR IS ALWAYS ON

When the BOREN bits of Configuration Words are programmed to '11', the BOR is always on. The device start-up will be delayed until the BOR is ready and VDD is higher than the BOR threshold.

BOR protection is active during Sleep. The BOR does not delay wake-up from Sleep.

### 5.2.2 BOR IS OFF IN SLEEP

When the BOREN bits of Configuration Words are programmed to '10', the BOR is on, except in Sleep. The device start-up will be delayed until the BOR is ready and VDD is higher than the BOR threshold.

BOR protection is not active during Sleep. The device wake-up will be delayed until the BOR is ready.

## 5.2 Brown-out Reset (BOR)

The BOR circuit holds the device in Reset when VDD reaches a selectable minimum level. Between the POR and BOR, complete voltage range coverage for execution protection can be implemented.

The Brown-out Reset module has four operating modes controlled by the BOREN<1:0> bits in Configuration Words. The four operating modes are:

- BOR is always on
- BOR is off when in Sleep
- BOR is controlled by software
- BOR is always off

Refer to [Table 5-1](#) for more information.

The Brown-out Reset voltage level is selectable by configuring the BORV bit in Configuration Words.

A VDD noise rejection filter prevents the BOR from triggering on small events. If VDD falls below VBOR for a duration greater than parameter TBORDC, the device will reset. See [Figure 5-2](#) for more information.

### 5.2.3 BOR CONTROLLED BY SOFTWARE

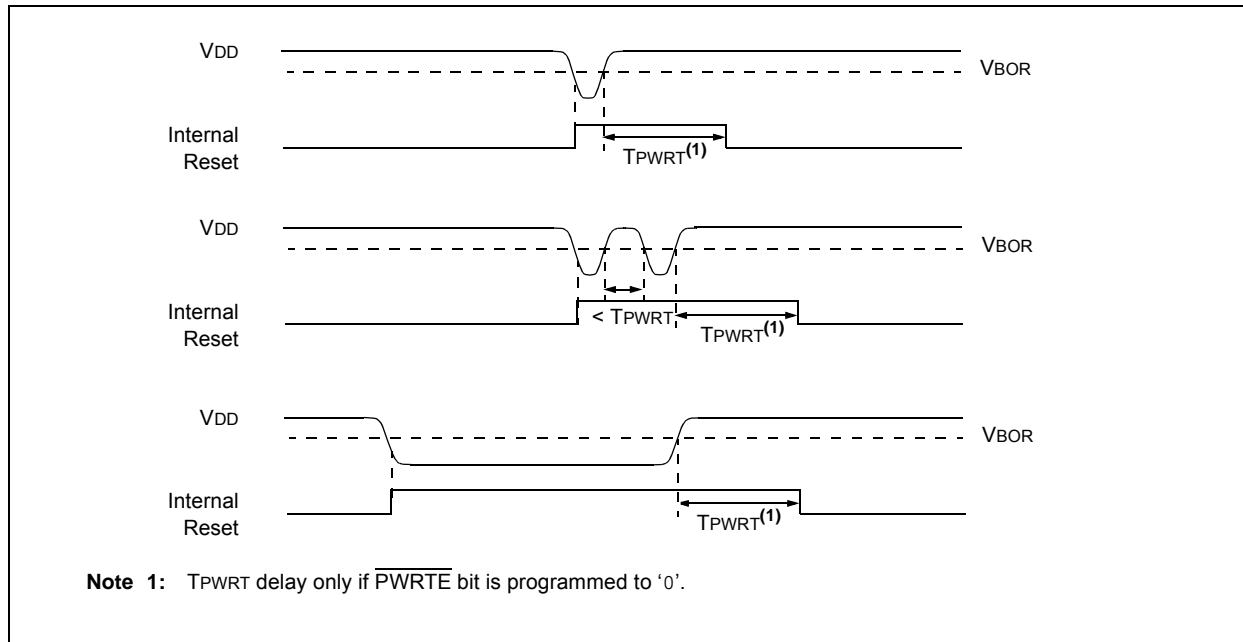
When the BOREN bits of Configuration Words are programmed to '01', the BOR is controlled by the SBOREN bit of the BORCON register. The device start-up is not delayed by the BOR ready condition or the VDD level.

BOR protection begins as soon as the BOR circuit is ready. The status of the BOR circuit is reflected in the BORRDY bit of the BORCON register.

BOR protection is unchanged by Sleep.

# PIC16(L)F1717/8/9

**FIGURE 5-2: BROWN-OUT SITUATIONS**



## 5.3 Register Definitions: BOR Control

**REGISTER 5-1: BORCON: BROWN-OUT RESET CONTROL REGISTER**

R/W-1/u	R/W-0/u	U-0	U-0	U-0	U-0	U-0	R-q/u
SBOREN	BORFS <sup>(1)</sup>	—	—	—	—	—	BORRDY
bit 7							bit 0

**Legend:**

R = Readable bit                      W = Writable bit                      U = Unimplemented bit, read as '0'  
u = Bit is unchanged                      x = Bit is unknown                      -n/n = Value at POR and BOR/Value at all other Resets  
'1' = Bit is set                              '0' = Bit is cleared                      q = Value depends on condition

bit 7                      **SBOREN:** Software Brown-out Reset Enable bit  
If BOREN<1:0> in Configuration Words ≠ 01:  
SBOREN is read/write, but has no effect on the BOR.  
If BOREN<1:0> in Configuration Words = 01:  
1 = BOR Enabled  
0 = BOR Disabled

bit 6                      **BORFS:** Brown-out Reset Fast Start bit<sup>(1)</sup>  
If BOREN<1:0> = 11 (Always on) or BOREN<1:0> = 00 (Always off)  
BORFS is Read/Write, but has no effect.  
If BOREN<1:0> = 10 (Disabled in Sleep) or BOREN<1:0> = 01 (Under software control):  
1 = Band gap is forced on always (covers sleep/wake-up/operating cases)  
0 = Band gap operates normally, and may turn off

bit 5-1                      **Unimplemented:** Read as '0'

bit 0                      **BORRDY:** Brown-out Reset Circuit Ready Status bit  
1 = The Brown-out Reset circuit is active  
0 = The Brown-out Reset circuit is inactive

**Note 1:** BOREN<1:0> bits are located in Configuration Words.

## 5.4 Low-Power Brown-out Reset (LPBOR)

The Low-Power Brown-out Reset (LPBOR) is an essential part of the Reset subsystem. Refer to [Figure 5-1](#) to see how the BOR interacts with other modules.

The LPBOR is used to monitor the external VDD pin. When too low of a voltage is detected, the device is held in Reset. When this occurs, a register bit ( $\overline{\text{BOR}}$ ) is changed to indicate that a BOR Reset has occurred. The same bit is set for both the BOR and the LPBOR. Refer to [Register 5-2](#).

### 5.4.1 ENABLING LPBOR

The LPBOR is controlled by the  $\overline{\text{LPBOR}}$  bit of Configuration Words. When the device is erased, the LPBOR module defaults to disabled.

#### 5.4.1.1 LPBOR Module Output

The output of the LPBOR module is a signal indicating whether or not a Reset is to be asserted. This signal is OR'd together with the Reset signal of the BOR module to provide the generic  $\overline{\text{BOR}}$  signal, which goes to the PCON register and to the power control block.

## 5.5 $\overline{\text{MCLR}}$

The  $\overline{\text{MCLR}}$  is an optional external input that can reset the device. The MCLR function is controlled by the MCLRE bit of Configuration Words and the LVP bit of Configuration Words ([Table 5-2](#)).

**TABLE 5-2:  $\overline{\text{MCLR}}$  CONFIGURATION**

MCLRE	LVP	$\overline{\text{MCLR}}$
0	0	Disabled
1	0	Enabled
x	1	Enabled

### 5.5.1 $\overline{\text{MCLR}}$ ENABLED

When  $\overline{\text{MCLR}}$  is enabled and the pin is held low, the device is held in Reset. The  $\overline{\text{MCLR}}$  pin is connected to VDD through an internal weak pull-up.

The device has a noise filter in the  $\overline{\text{MCLR}}$  Reset path. The filter will detect and ignore small pulses.

**Note:** A Reset does not drive the  $\overline{\text{MCLR}}$  pin low.

### 5.5.2 $\overline{\text{MCLR}}$ DISABLED

When  $\overline{\text{MCLR}}$  is disabled, the pin functions as a general purpose input and the internal weak pull-up is under software control. See [Section 11.1 “PORTA Registers”](#) for more information.

## 5.6 Watchdog Timer (WDT) Reset

The Watchdog Timer generates a Reset if the firmware does not issue a  $\overline{\text{CLRWDT}}$  instruction within the time-out period. The  $\overline{\text{TO}}$  and  $\overline{\text{PD}}$  bits in the STATUS register are changed to indicate the WDT Reset. See [Section 9.0 “Watchdog Timer \(WDT\)”](#) for more information.

## 5.7 RESET Instruction

A  $\overline{\text{RESET}}$  instruction will cause a device Reset. The  $\overline{\text{RI}}$  bit in the PCON register will be set to '0'. See [Table 5-4](#) for default conditions after a  $\overline{\text{RESET}}$  instruction has occurred.

## 5.8 Stack Overflow/Underflow Reset

The device can reset when the Stack Overflows or Underflows. The STKOVF or STKUNF bits of the PCON register indicate the Reset condition. These Resets are enabled by setting the STVREN bit in Configuration Words. See [Section 3.6.2 “Overflow/Underflow Reset”](#) for more information.

## 5.9 Programming Mode Exit

Upon exit of Programming mode, the device will behave as if a POR had just occurred.

## 5.10 Power-up Timer

The Power-up Timer optionally delays device execution after a BOR or POR event. This timer is typically used to allow VDD to stabilize before allowing the device to start running.

The Power-up Timer is controlled by the  $\overline{\text{PWRTEN}}$  bit of Configuration Words.

## 5.11 Start-up Sequence

Upon the release of a POR or BOR, the following must occur before the device will begin executing:

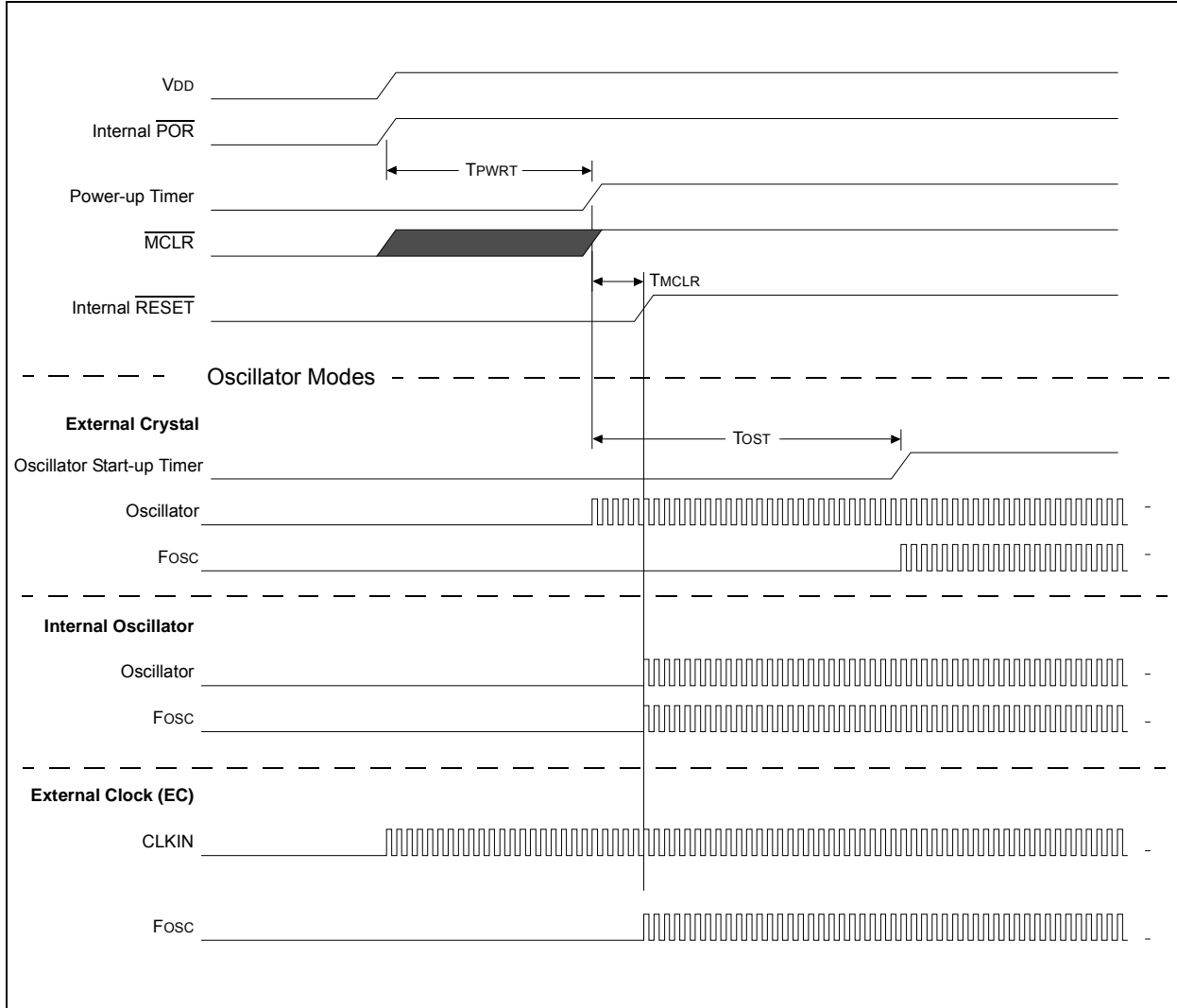
1. Power-up Timer runs to completion (if enabled).
2. Oscillator start-up timer runs to completion (if required for oscillator source).
3.  $\overline{\text{MCLR}}$  must be released (if enabled).

The total time-out will vary based on oscillator configuration and Power-up Timer configuration. See [Section 6.0 “Oscillator Module \(with Fail-Safe Clock Monitor\)”](#) for more information.

The Power-up Timer and oscillator start-up timer run independently of  $\overline{\text{MCLR}}$  Reset. If  $\overline{\text{MCLR}}$  is kept low long enough, the Power-up Timer and oscillator start-up timer will expire. Upon bringing  $\overline{\text{MCLR}}$  high, the device will begin execution after 10 FOSC cycles (see [Figure 5-3](#)). This is useful for testing purposes or to synchronize more than one device operating in parallel.

# PIC16(L)F1717/8/9

**FIGURE 5-3: RESET START-UP SEQUENCE**





## 5.12 Determining the Cause of a Reset

Upon any Reset, multiple bits in the STATUS and PCON register are updated to indicate the cause of the Reset. Table 5-3 and Table 5-4 show the Reset conditions of these registers.

**TABLE 5-3: RESET STATUS BITS AND THEIR SIGNIFICANCE**

STKOVF	STKUNF	RWD $\bar{T}$	RMCL $\bar{R}$	RI	POR	BOR	TO	PD	Condition
0	0	1	1	1	0	x	1	1	Power-on Reset
0	0	1	1	1	0	x	0	x	Illegal, $\bar{T}O$ is set on $\bar{P}OR$
0	0	1	1	1	0	x	x	0	Illegal, $\bar{P}D$ is set on $\bar{P}OR$
0	0	u	1	1	u	0	1	1	Brown-out Reset
u	u	0	u	u	u	u	0	u	WDT Reset
u	u	u	u	u	u	u	0	0	WDT Wake-up from Sleep
u	u	u	u	u	u	u	1	0	Interrupt Wake-up from Sleep
u	u	u	0	u	u	u	u	u	$\bar{M}CL\bar{R}$ Reset during normal operation
u	u	u	0	u	u	u	1	0	$\bar{M}CL\bar{R}$ Reset during Sleep
u	u	u	u	0	u	u	u	u	RESET Instruction Executed
1	u	u	u	u	u	u	u	u	Stack Overflow Reset (STVREN = 1)
u	1	u	u	u	u	u	u	u	Stack Underflow Reset (STVREN = 1)

**TABLE 5-4: RESET CONDITION FOR SPECIAL REGISTERS**

Condition	Program Counter	STATUS Register	PCON Register
Power-on Reset	0000h	---1 1000	00-- 110x
$\bar{M}CL\bar{R}$ Reset during normal operation	0000h	---u uuuu	uu-- 0uuu
$\bar{M}CL\bar{R}$ Reset during Sleep	0000h	---1 0uuu	uu-- 0uuu
WDT Reset	0000h	---0 uuuu	uu-- uuuu
WDT Wake-up from Sleep	PC + 1	---0 0uuu	uu-- uuuu
Brown-out Reset	0000h	---1 1uuu	00-- 11u0
Interrupt Wake-up from Sleep	PC + 1 <sup>(1)</sup>	---1 0uuu	uu-- uuuu
RESET Instruction Executed	0000h	---u uuuu	uu-- u0uu
Stack Overflow Reset (STVREN = 1)	0000h	---u uuuu	1u-- uuuu
Stack Underflow Reset (STVREN = 1)	0000h	---u uuuu	u1-- uuuu

**Legend:** u = unchanged, x = unknown, - = unimplemented bit, reads as '0'.

**Note 1:** When the wake-up is due to an interrupt and Global Enable bit (GIE) is set, the return address is pushed on the stack and PC is loaded with the interrupt vector (0004h) after execution of PC + 1.

# PIC16(L)F1717/8/9

## 5.13 Power Control (PCON) Register

The Power Control (PCON) register contains flag bits to differentiate between a:

- Power-on Reset ( $\overline{\text{POR}}$ )
- Brown-out Reset (BOR)
- Reset Instruction Reset ( $\overline{\text{RI}}$ )
- MCLR Reset ( $\overline{\text{RMCLR}}$ )
- Watchdog Timer Reset ( $\overline{\text{RWDT}}$ )
- Stack Underflow Reset (STKUNF)
- Stack Overflow Reset (STKOVF)

The PCON register bits are shown in [Register 5-2](#).

## 5.14 Register Definitions: Power Control

**REGISTER 5-2: PCON: POWER CONTROL REGISTER**

R/W/HS-0/q	R/W/HS-0/q	U-0	R/W/HC-1/q	R/W/HC-1/q	R/W/HC-1/q	R/W/HC-q/u	R/W/HC-q/u
STKOVF	STKUNF	—	$\overline{\text{RWDT}}$	$\overline{\text{RMCLR}}$	$\overline{\text{RI}}$	$\overline{\text{POR}}$	$\overline{\text{BOR}}$
bit 7							bit 0

**Legend:**

HC = Bit is cleared by hardware	HS = Bit is set by hardware
R = Readable bit	W = Writable bit
u = Bit is unchanged	x = Bit is unknown
'1' = Bit is set	'0' = Bit is cleared
	U = Unimplemented bit, read as '0'
	-m/n = Value at POR and BOR/Value at all other Resets
	q = Value depends on condition

- bit 7      **STKOVF:** Stack Overflow Flag bit  
 1 = A Stack Overflow occurred  
 0 = A Stack Overflow has not occurred or cleared by firmware
- bit 6      **STKUNF:** Stack Underflow Flag bit  
 1 = A Stack Underflow occurred  
 0 = A Stack Underflow has not occurred or cleared by firmware
- bit 5      **Unimplemented:** Read as '0'
- bit 4       **$\overline{\text{RWDT}}$ :** Watchdog Timer Reset Flag bit  
 1 = A Watchdog Timer Reset has not occurred or set to '1' by firmware  
 0 = A Watchdog Timer Reset has occurred (cleared by hardware)
- bit 3       **$\overline{\text{RMCLR}}$ :**  $\overline{\text{MCLR}}$  Reset Flag bit  
 1 = A  $\overline{\text{MCLR}}$  Reset has not occurred or set to '1' by firmware  
 0 = A  $\overline{\text{MCLR}}$  Reset has occurred (cleared by hardware)
- bit 2       **$\overline{\text{RI}}$ :** RESET Instruction Flag bit  
 1 = A RESET instruction has not been executed or set to '1' by firmware  
 0 = A RESET instruction has been executed (cleared by hardware)
- bit 1       **$\overline{\text{POR}}$ :** Power-on Reset Status bit  
 1 = No Power-on Reset occurred  
 0 = A Power-on Reset occurred (must be set in software after a Power-on Reset occurs)
- bit 0       **$\overline{\text{BOR}}$ :** Brown-out Reset Status bit  
 1 = No Brown-out Reset occurred  
 0 = A Brown-out Reset occurred (must be set in software after a Power-on Reset or Brown-out Reset occurs)

**TABLE 5-5: SUMMARY OF REGISTERS ASSOCIATED WITH RESETS**

Name	Bit 7	Bit 6	Bit 5	Bit 4	Bit 3	Bit 2	Bit 1	Bit 0	Register on Page
BORCON	SBOREN	BORFS	—	—	—	—	—	BORRDY	<a href="#">62</a>
PCON	STKOVF	STKUNF	—	$\overline{RWD\overline{T}}$	$\overline{RMCLR}$	$\overline{RI}$	$\overline{POR}$	$\overline{BOR}$	<a href="#">66</a>
STATUS	—	—	—	$\overline{TO}$	$\overline{PD}$	Z	DC	C	<a href="#">28</a>
WDTCON	—	—	WDTPS<4:0>					SWDTEN	<a href="#">104</a>

**Legend:** — = unimplemented location, read as '0'. Shaded cells are not used by Resets.

# PIC16(L)F1717/8/9

---

## 6.0 OSCILLATOR MODULE (WITH FAIL-SAFE CLOCK MONITOR)

### 6.1 Overview

The oscillator module has a wide variety of clock sources and selection features that allow it to be used in a wide range of applications while maximizing performance and minimizing power consumption. [Figure 6-1](#) illustrates a block diagram of the oscillator module.

Clock sources can be supplied from external oscillators, quartz crystal resonators, ceramic resonators and Resistor-Capacitor (RC) circuits. In addition, the system clock source can be supplied from one of two internal oscillators and PLL circuits, with a choice of speeds selectable via software. Additional clock features include:

- Selectable system clock source between external or internal sources via software
- Two-Speed Start-up mode, which minimizes latency between external oscillator start-up and code execution
- Fail-Safe Clock Monitor (FSCM) designed to detect a failure of the external clock source (LP, XT, HS, ECH, ECM, ECL or EXTRC modes) and switch automatically to the internal oscillator
- Oscillator Start-up Timer (OST), which ensures stability of crystal oscillator sources

The oscillator module can be configured in one of the following clock modes:

1. ECL – External Clock Low-Power mode (0 MHz to 0.5 MHz)
2. ECM – External Clock Medium Power mode (0.5 MHz to 4 MHz)
3. ECH – External Clock High-Power mode (4 MHz to 32 MHz)
4. LP – 32 kHz Low-Power Crystal mode.
5. XT – Medium Gain Crystal or Ceramic Resonator Oscillator mode (up to 4 MHz)
6. HS – High Gain Crystal or Ceramic Resonator mode (4 MHz to 20 MHz)
7. EXTRC – External Resistor-Capacitor
8. INTOSC – Internal oscillator (31 kHz to 32 MHz)

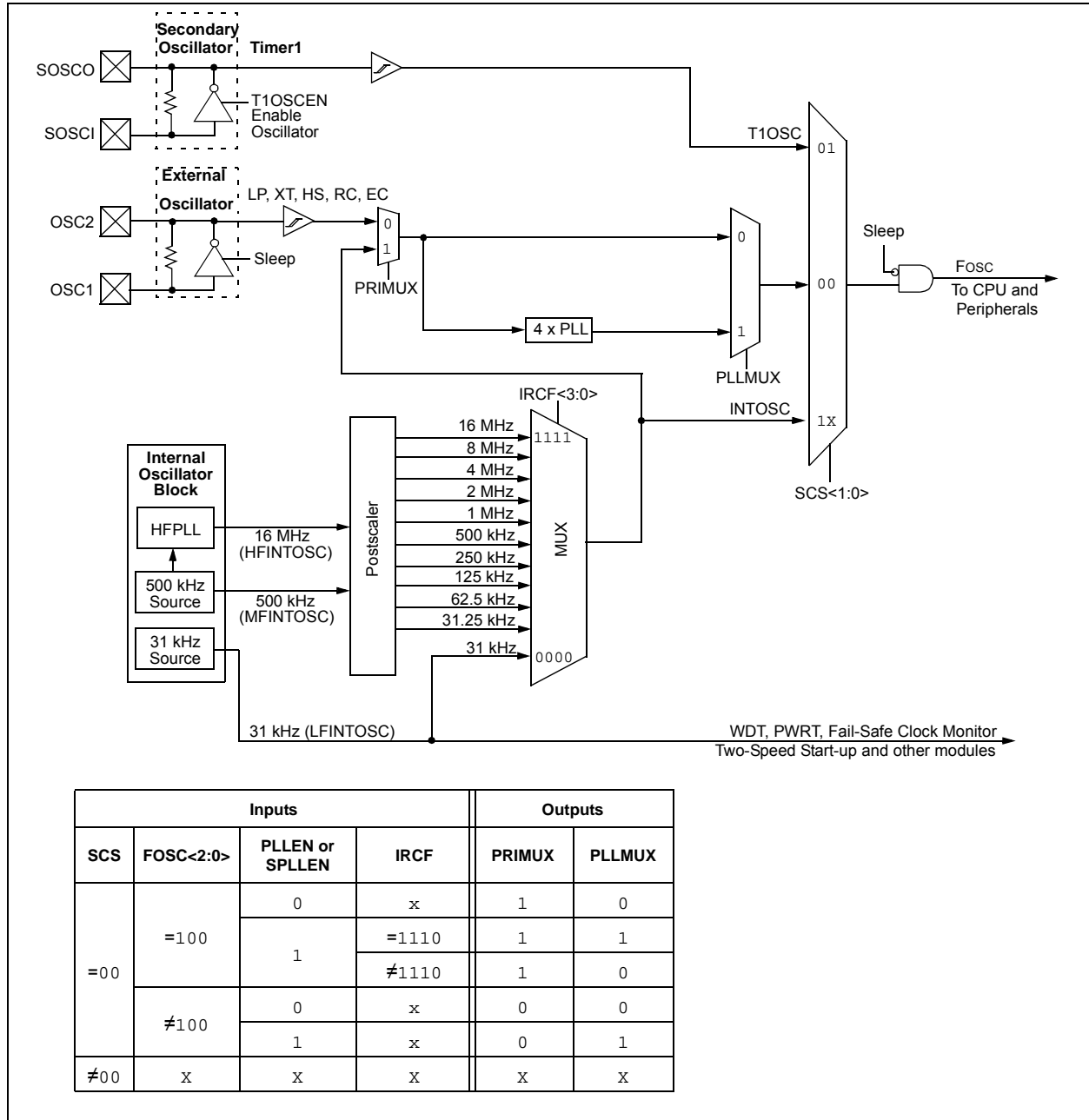
Clock Source modes are selected by the FOSC<2:0> bits in the Configuration Words. The FOSC bits determine the type of oscillator that will be used when the device is first powered.

The ECH, ECM, and ECL clock modes rely on an external logic level signal as the device clock source. The LP, XT, and HS clock modes require an external crystal or resonator to be connected to the device.

Each mode is optimized for a different frequency range. The EXTRC clock mode requires an external resistor and capacitor to set the oscillator frequency.

The INTOSC internal oscillator block produces low, medium, and high-frequency clock sources, designated LFINTOSC, MFINTOSC and HFINTOSC. (see Internal Oscillator Block, [Figure 6-1](#)). A wide selection of device clock frequencies may be derived from these three clock sources.

**FIGURE 6-1: SIMPLIFIED PIC® MCU CLOCK SOURCE BLOCK DIAGRAM**



# PIC16(L)F1717/8/9

## 6.2 Clock Source Types

Clock sources can be classified as external or internal.

External clock sources rely on external circuitry for the clock source to function. Examples are: oscillator modules (ECH, ECM, ECL mode), quartz crystal resonators or ceramic resonators (LP, XT and HS modes) and Resistor-Capacitor (EXTRC) mode circuits.

Internal clock sources are contained within the oscillator module. The internal oscillator block has two internal oscillators and a dedicated Phase-Lock Loop (HFPLL) that are used to generate three internal system clock sources: the 16 MHz High-Frequency Internal Oscillator (HFINTOSC), 500 kHz (MFINTOSC) and the 31 kHz Low-Frequency Internal Oscillator (LFINTOSC).

The system clock can be selected between external or internal clock sources via the System Clock Select (SCS) bits in the OSCCON register. See [Section 6.3 “Clock Switching”](#) for additional information.

### 6.2.1 EXTERNAL CLOCK SOURCES

An external clock source can be used as the device system clock by performing one of the following actions:

- Program the FOSC<2:0> bits in the Configuration Words to select an external clock source that will be used as the default system clock upon a device Reset.
- Write the SCS<1:0> bits in the OSCCON register to switch the system clock source to:
  - Secondary oscillator during run-time, or
  - An external clock source determined by the value of the FOSC bits.

See [Section 6.3 “Clock Switching”](#) for more information.

#### 6.2.1.1 EC Mode

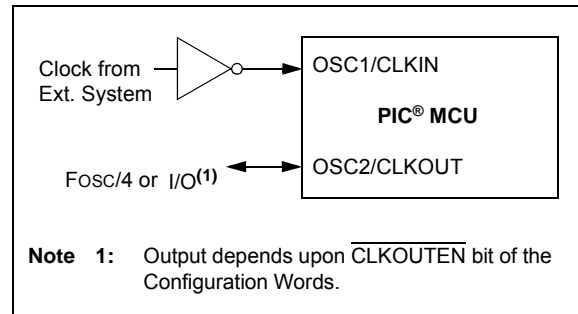
The External Clock (EC) mode allows an externally generated logic level signal to be the system clock source. When operating in this mode, an external clock source is connected to the OSC1 input. OSC2/CLKOUT is available for general purpose I/O or CLKOUT. [Figure 6-2](#) shows the pin connections for EC mode.

EC mode has three power modes to select from through Configuration Words:

- ECH – High power, 4-32 MHz
- ECM – Medium power, 0.5-4 MHz
- ECL – Low power, 0-0.5 MHz

The Oscillator Start-up Timer (OST) is disabled when EC mode is selected. Therefore, there is no delay in operation after a Power-on Reset (POR) or wake-up from Sleep. Because the PIC® MCU design is fully static, stopping the external clock input will have the effect of halting the device while leaving all data intact. Upon restarting the external clock, the device will resume operation as if no time had elapsed.

**FIGURE 6-2: EXTERNAL CLOCK (EC) MODE OPERATION**



#### 6.2.1.2 LP, XT, HS Modes

The LP, XT and HS modes support the use of quartz crystal resonators or ceramic resonators connected to OSC1 and OSC2 (see [Figure 6-3](#)). The three modes select a low, medium or high gain setting of the internal inverter-amplifier to support various resonator types and speed.

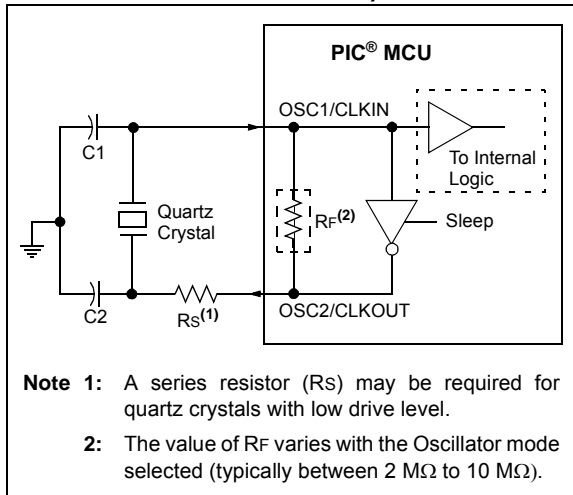
**LP** Oscillator mode selects the lowest gain setting of the internal inverter-amplifier. LP mode current consumption is the least of the three modes. This mode is designed to drive only 32.768 kHz tuning-fork type crystals (watch crystals).

**XT** Oscillator mode selects the intermediate gain setting of the internal inverter-amplifier. XT mode current consumption is the medium of the three modes. This mode is best suited to drive resonators with a medium drive level specification.

**HS** Oscillator mode selects the highest gain setting of the internal inverter-amplifier. HS mode current consumption is the highest of the three modes. This mode is best suited for resonators that require a high drive setting.

[Figure 6-3](#) and [Figure 6-4](#) show typical circuits for quartz crystal and ceramic resonators, respectively.

**FIGURE 6-3: QUARTZ CRYSTAL OPERATION (LP, XT OR HS MODE)**



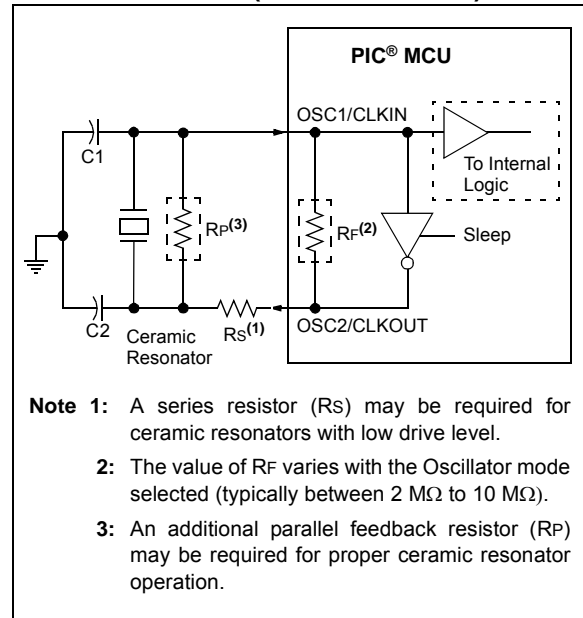
**Note 1:** Quartz crystal characteristics vary according to type, package and manufacturer. The user should consult the manufacturer data sheets for specifications and recommended application.

**2:** Always verify oscillator performance over the  $V_{DD}$  and temperature range that is expected for the application.

**3:** For oscillator design assistance, reference the following Microchip Application Notes:

- AN826, “Crystal Oscillator Basics and Crystal Selection for rPIC<sup>®</sup> and PIC<sup>®</sup> Devices” (DS00826)
- AN849, “Basic PIC<sup>®</sup> Oscillator Design” (DS00849)
- AN943, “Practical PIC<sup>®</sup> Oscillator Analysis and Design” (DS00943)
- AN949, “Making Your Oscillator Work” (DS00949)

**FIGURE 6-4: CERAMIC RESONATOR OPERATION (XT OR HS MODE)**



### 6.2.1.3 Oscillator Start-up Timer (OST)

If the oscillator module is configured for LP, XT or HS modes, the Oscillator Start-up Timer (OST) counts 1024 oscillations from OSC1. This occurs following a Power-on Reset (POR) and when the Power-up Timer (PWRT) has expired (if configured), or a wake-up from Sleep. During this time, the program counter does not increment and program execution is suspended, unless either FSCM or Two-Speed Start-Up are enabled. In this case, code will continue to execute at the selected INTOSC frequency while the OST is counting. The OST ensures that the oscillator circuit, using a quartz crystal resonator or ceramic resonator, has started and is providing a stable system clock to the oscillator module.

In order to minimize latency between external oscillator start-up and code execution, the Two-Speed Clock Start-up mode can be selected (see [Section 6.4 “Two-Speed Clock Start-up Mode”](#)).

# PIC16(L)F1717/8/9

## 6.2.1.4 4x PLL

The oscillator module contains a 4x PLL that can be used with both external and internal clock sources to provide a system clock source. The input frequency for the 4x PLL must fall within specifications. See the PLL Clock Timing Specifications in [Table 34-9: PLL Clock Timing Specifications](#).

The 4x PLL may be enabled for use by one of two methods:

1. Program the PLEN bit in Configuration Words to a '1'.
2. Write the SPLLEN bit in the OSCCON register to a '1'. If the PLEN bit in Configuration Words is programmed to a '1', then the value of SPLLEN is ignored.

## 6.2.1.5 Secondary Oscillator

The secondary oscillator is a separate crystal oscillator that is associated with the Timer1 peripheral. It is optimized for timekeeping operations with a 32.768 kHz crystal connected between the SOSCO and SOSCI device pins.

The secondary oscillator can be used as an alternate system clock source and can be selected during run-time using clock switching. Refer to [Section 6.3 "Clock Switching"](#) for more information.

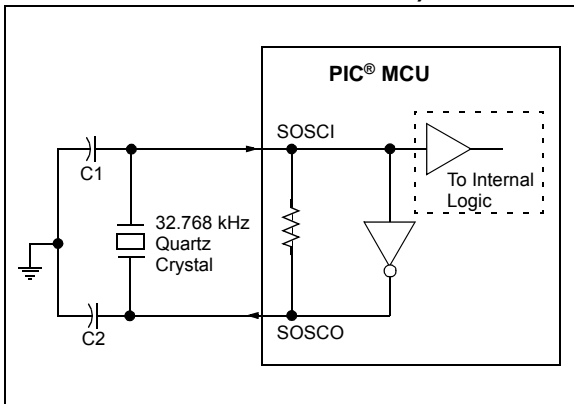
**Note 1:** Quartz crystal characteristics vary according to type, package and manufacturer. The user should consult the manufacturer data sheets for specifications and recommended application.

**2:** Always verify oscillator performance over the VDD and temperature range that is expected for the application.

**3:** For oscillator design assistance, reference the following Microchip Application Notes:

- AN826, "Crystal Oscillator Basics and Crystal Selection for *rPIC*® and *PIC*® Devices" (DS00826)
- AN849, "Basic *PIC*® Oscillator Design" (DS00849)
- AN943, "Practical *PIC*® Oscillator Analysis and Design" (DS00943)
- AN949, "Making Your Oscillator Work" (DS00949)
- TB097, "Interfacing a Micro Crystal MS1V-T1K 32.768 kHz Tuning Fork Crystal to a *PIC16F690/SS*" (DS91097)
- AN1288, "Design Practices for Low-Power External Oscillators" (DS01288)

**FIGURE 6-5: QUARTZ CRYSTAL OPERATION (SECONDARY OSCILLATOR)**





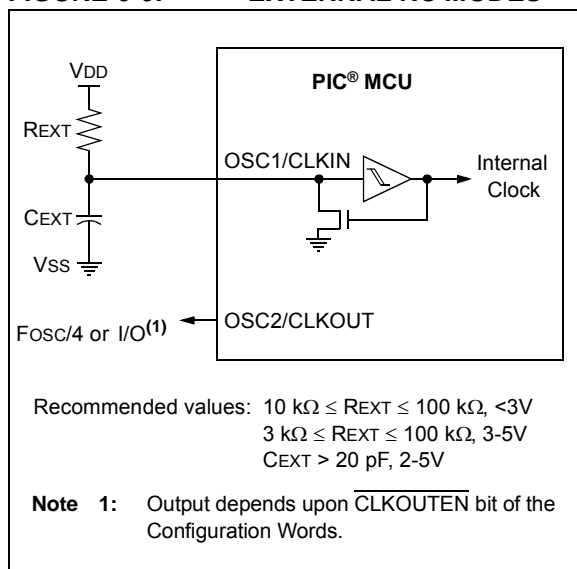
## 6.2.1.6 External RC Mode

The external Resistor-Capacitor (EXTRC) mode supports the use of an external RC circuit. This allows the designer maximum flexibility in frequency choice while keeping costs to a minimum when clock accuracy is not required.

The RC circuit connects to OSC1. OSC2/CLKOUT is available for general purpose I/O or CLKOUT. The function of the OSC2/CLKOUT pin is determined by the CLKOUTEN bit in Configuration Words.

Figure 6-6 shows the external RC mode connections.

**FIGURE 6-6: EXTERNAL RC MODES**



The RC oscillator frequency is a function of the supply voltage, the resistor ( $R_{EXT}$ ) and capacitor ( $C_{EXT}$ ) values and the operating temperature. Other factors affecting the oscillator frequency are:

- Threshold voltage variation
- Component tolerances
- Packaging variations in capacitance

The user also needs to take into account variation due to tolerance of external RC components used.

## 6.2.2 INTERNAL CLOCK SOURCES

The device may be configured to use the internal oscillator block as the system clock by performing one of the following actions:

- Program the FOSC<2:0> bits in Configuration Words to select the INTOSC clock source, which will be used as the default system clock upon a device Reset.
- Write the SCS<1:0> bits in the OSCCON register to switch the system clock source to the internal oscillator during run-time. See [Section 6.3 “Clock Switching”](#) for more information.

In INTOSC mode, OSC1/CLKIN is available for general purpose I/O. OSC2/CLKOUT is available for general purpose I/O or CLKOUT.

The function of the OSC2/CLKOUT pin is determined by the CLKOUTEN bit in Configuration Words.

The internal oscillator block has two independent oscillators and a dedicated Phase-Lock Loop, HFPLL that can produce one of three internal system clock sources.

1. The **HFINTOSC** (High-Frequency Internal Oscillator) is factory calibrated and operates at 16 MHz. The HFINTOSC source is generated from the 500 kHz MFINTOSC source and the dedicated Phase-Lock Loop, HFPLL. The frequency of the HFINTOSC can be user-adjusted via software using the OSCTUNE register ([Register 6-3](#)).
2. The **MFINTOSC** (Medium Frequency Internal Oscillator) is factory calibrated and operates at 500 kHz. The frequency of the MFINTOSC can be user-adjusted via software using the OSCTUNE register ([Register 6-3](#)).
3. The **LFINTOSC** (Low-Frequency Internal Oscillator) is uncalibrated and operates at 31 kHz.

# PIC16(L)F1717/8/9

## 6.2.2.1 HFINTOSC

The High-Frequency Internal Oscillator (HFINTOSC) is a factory calibrated 16 MHz internal clock source. The frequency of the HFINTOSC can be altered via software using the OSCTUNE register ([Register 6-3](#)).

The output of the HFINTOSC connects to a postscaler and multiplexer (see [Figure 6-1](#)). One of multiple frequencies derived from the HFINTOSC can be selected via software using the IRCF<3:0> bits of the OSCCON register. See [Section 6.2.2.7 “Internal Oscillator Clock Switch Timing”](#) for more information.

The HFINTOSC is enabled by:

- Configure the IRCF<3:0> bits of the OSCCON register for the desired HF frequency, and
- FOSC<2:0> = 100, or
- Set the System Clock Source (SCS) bits of the OSCCON register to '1x'

A fast start-up oscillator allows internal circuits to power up and stabilize before switching to HFINTOSC.

The High-Frequency Internal Oscillator Ready bit (HFIOFR) of the OSCSTAT register indicates when the HFINTOSC is running.

The High-Frequency Internal Oscillator Status Locked bit (HFIOFL) of the OSCSTAT register indicates when the HFINTOSC is running within 2% of its final value.

The High-Frequency Internal Oscillator Stable bit (HFIOFS) of the OSCSTAT register indicates when the HFINTOSC is running within 0.5% of its final value.

## 6.2.2.2 MFINTOSC

The Medium Frequency Internal Oscillator (MFINTOSC) is a factory calibrated 500 kHz internal clock source. The frequency of the MFINTOSC can be altered via software using the OSCTUNE register ([Register 6-3](#)).

The output of the MFINTOSC connects to a postscaler and multiplexer (see [Figure 6-1](#)). One of nine frequencies derived from the MFINTOSC can be selected via software using the IRCF<3:0> bits of the OSCCON register. See [Section 6.2.2.7 “Internal Oscillator Clock Switch Timing”](#) for more information.

The MFINTOSC is enabled by:

- Configure the IRCF<3:0> bits of the OSCCON register for the desired HF frequency, and
- FOSC<2:0> = 100, or
- Set the System Clock Source (SCS) bits of the OSCCON register to '1x'

The Medium Frequency Internal Oscillator Ready bit (MFIOFR) of the OSCSTAT register indicates when the MFINTOSC is running.

## 6.2.2.3 Internal Oscillator Frequency Adjustment

The 500 kHz internal oscillator is factory calibrated. This internal oscillator can be adjusted in software by writing to the OSCTUNE register ([Register 6-3](#)). Since the HFINTOSC and MFINTOSC clock sources are derived from the 500 kHz internal oscillator a change in the OSCTUNE register value will apply to both.

The default value of the OSCTUNE register is '0'. The value is a 6-bit two's complement number. A value of 1Fh will provide an adjustment to the maximum frequency. A value of 20h will provide an adjustment to the minimum frequency.

When the OSCTUNE register is modified, the oscillator frequency will begin shifting to the new frequency. Code execution continues during this shift. There is no indication that the shift has occurred.

OSCTUNE does not affect the LFINTOSC frequency. Operation of features that depend on the LFINTOSC clock source frequency, such as the Power-up Timer (PWRT), Watchdog Timer (WDT), Fail-Safe Clock Monitor (FSCM) and peripherals, are *not* affected by the change in frequency.

## 6.2.2.4 LFINTOSC

The Low-Frequency Internal Oscillator (LFINTOSC) is an uncalibrated 31 kHz internal clock source.

The output of the LFINTOSC connects to a multiplexer (see [Figure 6-1](#)). Select 31 kHz, via software, using the IRCF<3:0> bits of the OSCCON register. See [Section 6.2.2.7 “Internal Oscillator Clock Switch Timing”](#) for more information. The LFINTOSC is also the frequency for the Power-up Timer (PWRT), Watchdog Timer (WDT) and Fail-Safe Clock Monitor (FSCM).

The LFINTOSC is enabled by selecting 31 kHz (IRCF<3:0> bits of the OSCCON register = 000) as the system clock source (SCS bits of the OSCCON register = 1x), or when any of the following are enabled:

- Configure the IRCF<3:0> bits of the OSCCON register for the desired LF frequency, and
- FOSC<2:0> = 100, or
- Set the System Clock Source (SCS) bits of the OSCCON register to '1x'

Peripherals that use the LFINTOSC are:

- Power-up Timer (PWRT)
- Watchdog Timer (WDT)
- Fail-Safe Clock Monitor (FSCM)

The Low-Frequency Internal Oscillator Ready bit (LFIOFR) of the OSCSTAT register indicates when the LFINTOSC is running.

## 6.2.2.5 Internal Oscillator Frequency Selection

The system clock speed can be selected via software using the Internal Oscillator Frequency Select bits  $IRCF<3:0>$  of the OSCCON register.

The postscaled output of the 16 MHz HFINTOSC, 500 kHz MFINTOSC, and 31 kHz LFINTOSC connect to a multiplexer (see [Figure 6-1](#)). The Internal Oscillator Frequency Select bits  $IRCF<3:0>$  of the OSCCON register select the frequency output of the internal oscillators. One of the following frequencies can be selected via software:

- 32 MHz (requires 4 x PLL)
- 16 MHz
- 8 MHz
- 4 MHz
- 2 MHz
- 1 MHz
- 500 kHz (default after Reset)
- 250 kHz
- 125 kHz
- 62.5 kHz
- 31.25 kHz
- 31 kHz (LFINTOSC)

**Note:** Following any Reset, the  $IRCF<3:0>$  bits of the OSCCON register are set to '0111' and the frequency selection is set to 500 kHz. The user can modify the  $IRCF$  bits to select a different frequency.

The  $IRCF<3:0>$  bits of the OSCCON register allow duplicate selections for some frequencies. These duplicate choices can offer system design trade-offs. Lower power consumption can be obtained when changing oscillator sources for a given frequency. Faster transition times can be obtained between frequency changes that use the same oscillator source.

## 6.2.2.6 32 MHz Internal Oscillator Frequency Selection

The Internal Oscillator Block can be used with the 4x PLL associated with the External Oscillator Block to produce a 32 MHz internal system clock source. The following settings are required to use the 32 MHz internal clock source:

- The FOSC bits in Configuration Words must be set to use the INTOSC source as the device system clock ( $FOSC<2:0> = 100$ ).
- The SCS bits in the OSCCON register must be cleared to use the clock determined by  $FOSC<2:0>$  in Configuration Words ( $SCS<1:0> = 00$ ).
- The  $IRCF$  bits in the OSCCON register must be set to the 8 MHz HFINTOSC set to use ( $IRCF<3:0> = 1110$ ).
- The SPLLEN bit in the OSCCON register must be set to enable the 4x PLL, or the PLEN bit of the Configuration Words must be programmed to a '1'.

**Note:** When using the PLEN bit of the Configuration Words, the 4x PLL cannot be disabled by software and the SPLLEN option will not be available.

The 4x PLL is not available for use with the internal oscillator when the SCS bits of the OSCCON register are set to '1x'. The SCS bits must be set to '00' to use the 4x PLL with the internal oscillator.

# PIC16(L)F1717/8/9

---

## 6.2.2.7 Internal Oscillator Clock Switch Timing

When switching between the HFINTOSC, MFINTOSC and the LFINTOSC, the new oscillator may already be shut down to save power (see [Figure 6-7](#)). If this is the case, there is a delay after the IRCF<3:0> bits of the OSCCON register are modified before the frequency selection takes place. The OSCSTAT register will reflect the current active status of the HFINTOSC, MFINTOSC and LFINTOSC oscillators. The sequence of a frequency selection is as follows:

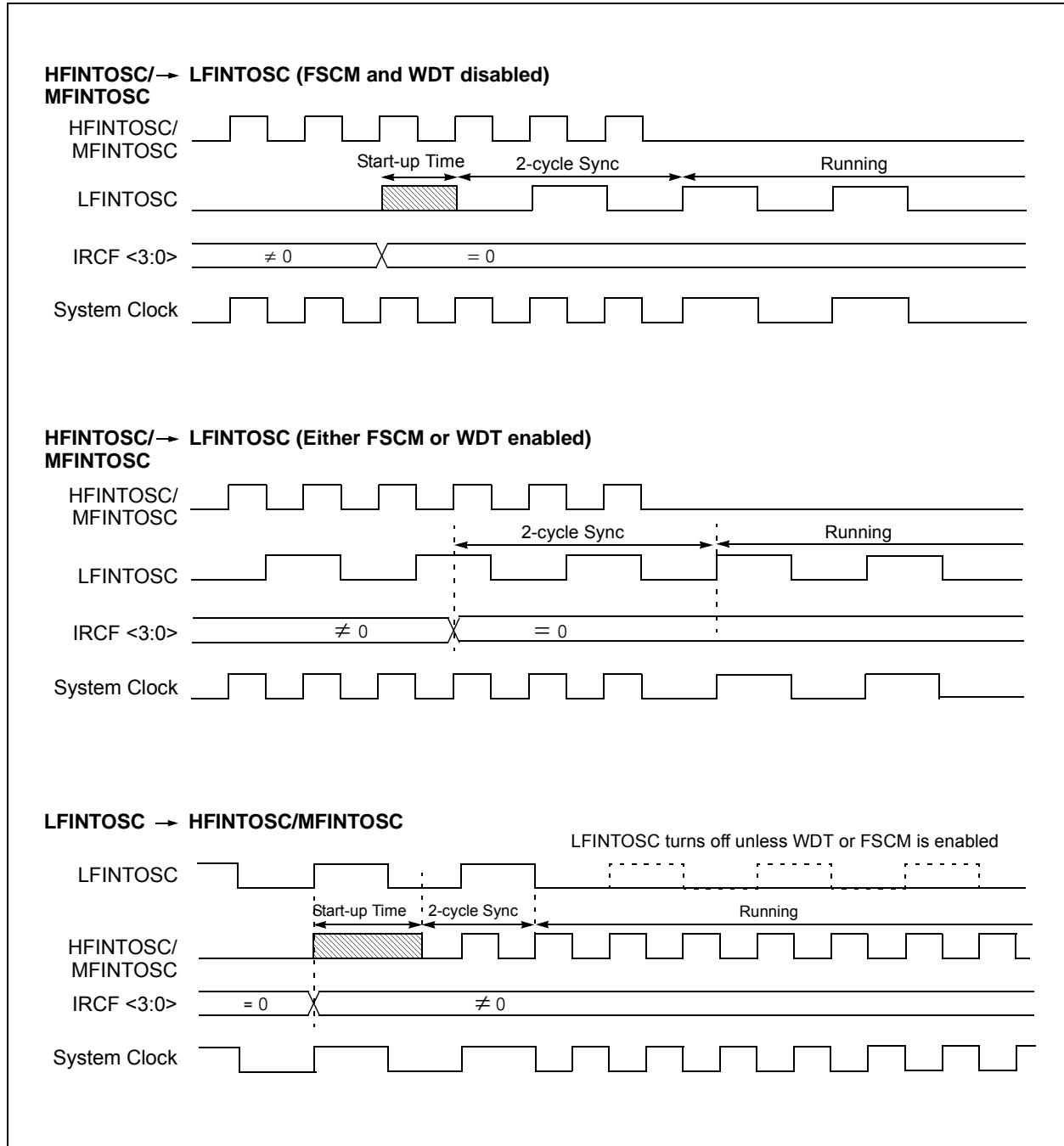
1. IRCF<3:0> bits of the OSCCON register are modified.
2. If the new clock is shut down, a clock start-up delay is started.
3. Clock switch circuitry waits for a falling edge of the current clock.
4. The current clock is held low and the clock switch circuitry waits for a rising edge in the new clock.
5. The new clock is now active.
6. The OSCSTAT register is updated as required.
7. Clock switch is complete.

See [Figure 6-7](#) for more details.

If the internal oscillator speed is switched between two clocks of the same source, there is no start-up delay before the new frequency is selected. Clock switching time delays are shown in [Table 6-1](#).

Start-up delay specifications are located in the oscillator tables of [Section 34.0 “Electrical Specifications”](#).

**FIGURE 6-7: INTERNAL OSCILLATOR SWITCH TIMING**



# PIC16(L)F1717/8/9

## 6.3 Clock Switching

The system clock source can be switched between external and internal clock sources via software using the System Clock Select (SCS) bits of the OSCCON register. The following clock sources can be selected using the SCS bits:

- Default system oscillator determined by FOSC bits in Configuration Words
- Timer1 32 kHz crystal oscillator
- Internal Oscillator Block (INTOSC)

### 6.3.1 SYSTEM CLOCK SELECT (SCS) BITS

The System Clock Select (SCS) bits of the OSCCON register select the system clock source that is used for the CPU and peripherals.

- When the SCS bits of the OSCCON register = 00, the system clock source is determined by the value of the FOSC<2:0> bits in the Configuration Words.
- When the SCS bits of the OSCCON register = 01, the system clock source is the secondary oscillator.
- When the SCS bits of the OSCCON register = 1x, the system clock source is chosen by the internal oscillator frequency selected by the IRCF<3:0> bits of the OSCCON register. After a Reset, the SCS bits of the OSCCON register are always cleared.

**Note:** Any automatic clock switch, which may occur from Two-Speed Start-up or Fail-Safe Clock Monitor, does not update the SCS bits of the OSCCON register. The user can monitor the OSTS bit of the OSCSTAT register to determine the current system clock source.

When switching between clock sources, a delay is required to allow the new clock to stabilize. These oscillator delays are shown in [Table 6-1](#).

### 6.3.2 OSCILLATOR START-UP TIMER STATUS (OSTS) BIT

The Oscillator Start-up Timer Status (OSTS) bit of the OSCSTAT register indicates whether the system clock is running from the external clock source, as defined by the FOSC<2:0> bits in the Configuration Words, or from the internal clock source. In particular, OSTS indicates that the Oscillator Start-up Timer (OST) has timed out for LP, XT or HS modes. The OST does not reflect the status of the secondary oscillator.

### 6.3.3 SECONDARY OSCILLATOR

The secondary oscillator is a separate crystal oscillator associated with the Timer1 peripheral. It is optimized for timekeeping operations with a 32.768 kHz crystal connected between the SOSCO and SOSCI device pins.

The secondary oscillator is enabled using the T1OSCEN control bit in the T1CON register. See [Section 27.0 “Timer1 Module with Gate Control”](#) for more information about the Timer1 peripheral.

### 6.3.4 SECONDARY OSCILLATOR READY (SOSCR) BIT

The user must ensure that the secondary oscillator is ready to be used before it is selected as a system clock source. The Secondary Oscillator Ready (SOSCR) bit of the OSCSTAT register indicates whether the secondary oscillator is ready to be used. After the SOSCR bit is set, the SCS bits can be configured to select the secondary oscillator.

### 6.3.5 CLOCK SWITCHING BEFORE SLEEP

When clock switching from an old clock to a new clock is requested just prior to entering Sleep mode, it is necessary to confirm that the switch is complete before the SLEEP instruction is executed. Failure to do so may result in an incomplete switch and consequential loss of the system clock altogether. Clock switching is confirmed by monitoring the clock status bits in the OSCSTAT register. Switch confirmation can be accomplished by sensing that the ready bit for the new clock is set or the ready bit for the old clock is cleared. For example, when switching between the internal oscillator with the PLL and the internal oscillator without the PLL, monitor the PLLR bit. When PLLR is set, the switch to 32 MHz operation is complete. Conversely, when PLLR is cleared, the switch from 32 MHz operation to the selected internal clock is complete.

## 6.4 Two-Speed Clock Start-up Mode

Two-Speed Start-up mode provides additional power savings by minimizing the latency between external oscillator start-up and code execution. In applications that make heavy use of the Sleep mode, Two-Speed Start-up will remove the external oscillator start-up time from the time spent awake and can reduce the overall power consumption of the device. This mode allows the application to wake-up from Sleep, perform a few instructions using the INTOSC internal oscillator block as the clock source and go back to Sleep without waiting for the external oscillator to become stable.

Two-Speed Start-up provides benefits when the oscillator module is configured for LP, XT or HS modes. The Oscillator Start-up Timer (OST) is enabled for these modes and must count 1024 oscillations before the oscillator can be used as the system clock source.

If the oscillator module is configured for any mode other than LP, XT or HS mode, then Two-Speed Start-up is disabled. This is because the external clock oscillator does not require any stabilization time after POR or an exit from Sleep.

If the OST count reaches 1024 before the device enters Sleep mode, the OSTS bit of the OSCSTAT register is set and program execution switches to the external oscillator. However, the system may never operate from the external oscillator if the time spent awake is very short.

**Note:** Executing a `SLEEP` instruction will abort the oscillator start-up time and will cause the OSTS bit of the OSCSTAT register to remain clear.

### 6.4.1 TWO-SPEED START-UP MODE CONFIGURATION

Two-Speed Start-up mode is configured by the following settings:

- IESO (of the Configuration Words) = 1; Internal/External Switchover bit (Two-Speed Start-up mode enabled).
- SCS (of the OSCCON register) = 00.
- FOSC<2:0> bits in the Configuration Words configured for LP, XT or HS mode.

Two-Speed Start-up mode is entered after:

- Power-on Reset (POR) and, if enabled, after Power-up Timer (PWRT) has expired, or
- Wake-up from Sleep.

**TABLE 6-1: OSCILLATOR SWITCHING DELAYS**

Switch From	Switch To	Frequency	Oscillator Delay
Sleep	LFINTOSC <sup>(1)</sup> MFINTOSC <sup>(1)</sup> HFINTOSC <sup>(1)</sup>	31 kHz 31.25 kHz-500 kHz 31.25 kHz-16 MHz	Oscillator Warm-up Delay (TWARM) <sup>(2)</sup>
Sleep/POR	EC, RC <sup>(1)</sup>	DC – 32 MHz	2 cycles
LFINTOSC	EC, RC <sup>(1)</sup>	DC – 32 MHz	1 cycle of each
Sleep/POR	Secondary Oscillator LP, XT, HS <sup>(1)</sup>	32 kHz-20 MHz	1024 Clock Cycles (OST)
Any clock source	MFINTOSC <sup>(1)</sup> HFINTOSC <sup>(1)</sup>	31.25 kHz-500 kHz 31.25 kHz-16 MHz	2 μs (approx.)
Any clock source	LFINTOSC <sup>(1)</sup>	31 kHz	1 cycle of each
Any clock source	Secondary Oscillator	32 kHz	1024 Clock Cycles (OST)
PLL inactive	PLL active	16-32 MHz	2 ms (approx.)

**Note 1:** PLL inactive.

**2:** See [Section 34.0 “Electrical Specifications”](#).

# PIC16(L)F1717/8/9

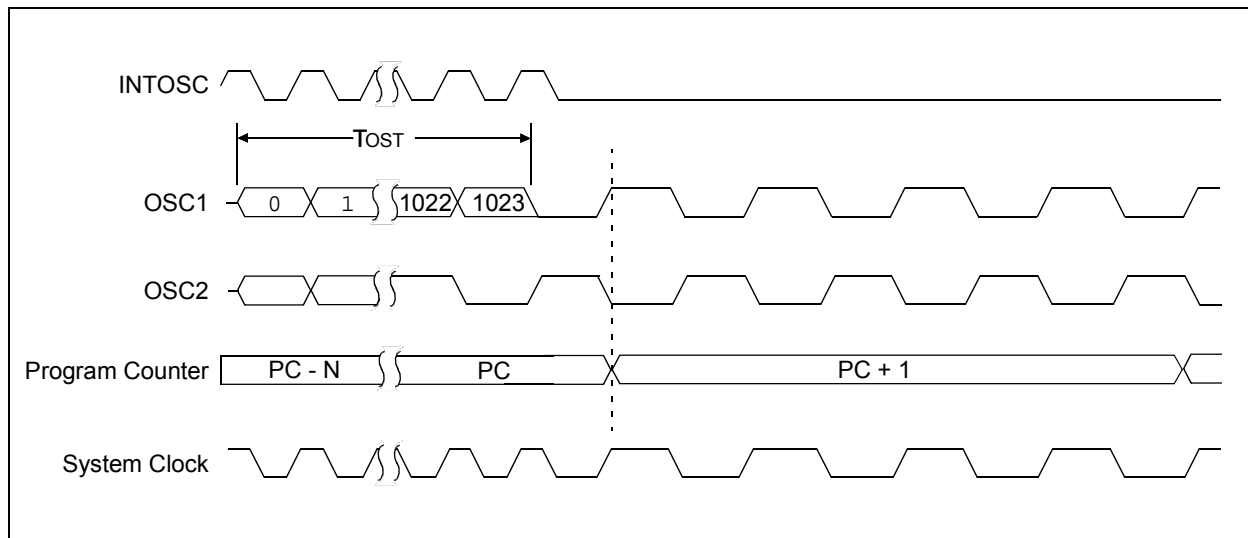
## 6.4.2 TWO-SPEED START-UP SEQUENCE

1. Wake-up from Power-on Reset or Sleep.
2. Instructions begin execution by the internal oscillator at the frequency set in the IRCF<3:0> bits of the OSCCON register.
3. OST enabled to count 1024 clock cycles.
4. OST timed out, wait for falling edge of the internal oscillator.
5. OSTS is set.
6. System clock held low until the next falling edge of new clock (LP, XT or HS mode).
7. System clock is switched to external clock source.

## 6.4.3 CHECKING TWO-SPEED CLOCK STATUS

Checking the state of the OSTS bit of the OSCSTAT register will confirm if the microcontroller is running from the external clock source, as defined by the FOSC<2:0> bits in the Configuration Words, or the internal oscillator.

**FIGURE 6-8: TWO-SPEED START-UP**

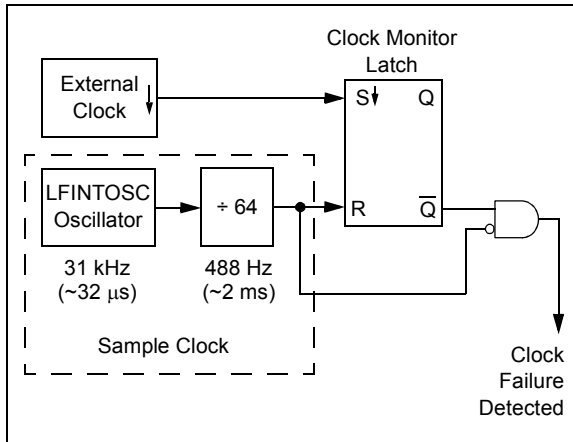




## 6.5 Fail-Safe Clock Monitor

The Fail-Safe Clock Monitor (FSCM) allows the device to continue operating should the external oscillator fail. The FSCM can detect oscillator failure any time after the Oscillator Start-up Timer (OST) has expired. The FSCM is enabled by setting the FCMEN bit in the Configuration Words. The FSCM is applicable to all external Oscillator modes (LP, XT, HS, EC, Secondary Oscillator and RC).

**FIGURE 6-9: FSCM BLOCK DIAGRAM**



### 6.5.1 FAIL-SAFE DETECTION

The FSCM module detects a failed oscillator by comparing the external oscillator to the FSCM sample clock. The sample clock is generated by dividing the LFINTOSC by 64. See Figure 6-9. Inside the fail detector block is a latch. The external clock sets the latch on each falling edge of the external clock. The sample clock clears the latch on each rising edge of the sample clock. A failure is detected when an entire half-cycle of the sample clock elapses before the external clock goes low.

### 6.5.2 FAIL-SAFE OPERATION

When the external clock fails, the FSCM switches the device clock to an internal clock source and sets the bit flag OSFIF of the PIR2 register. Setting this flag will generate an interrupt if the OSFIE bit of the PIE2 register is also set. The device firmware can then take steps to mitigate the problems that may arise from a failed clock. The system clock will continue to be sourced from the internal clock source until the device firmware successfully restarts the external oscillator and switches back to external operation.

The internal clock source chosen by the FSCM is determined by the IRCF<3:0> bits of the OSCCON register. This allows the internal oscillator to be configured before a failure occurs.

### 6.5.3 FAIL-SAFE CONDITION CLEARING

The Fail-Safe condition is cleared after a Reset, executing a SLEEP instruction or changing the SCS bits of the OSCCON register. When the SCS bits are changed, the OST is restarted. While the OST is running, the device continues to operate from the INTOSC selected in OSCCON. When the OST times out, the Fail-Safe condition is cleared after successfully switching to the external clock source. The OSFIF bit should be cleared prior to switching to the external clock source. If the Fail-Safe condition still exists, the OSFIF flag will again become set by hardware.

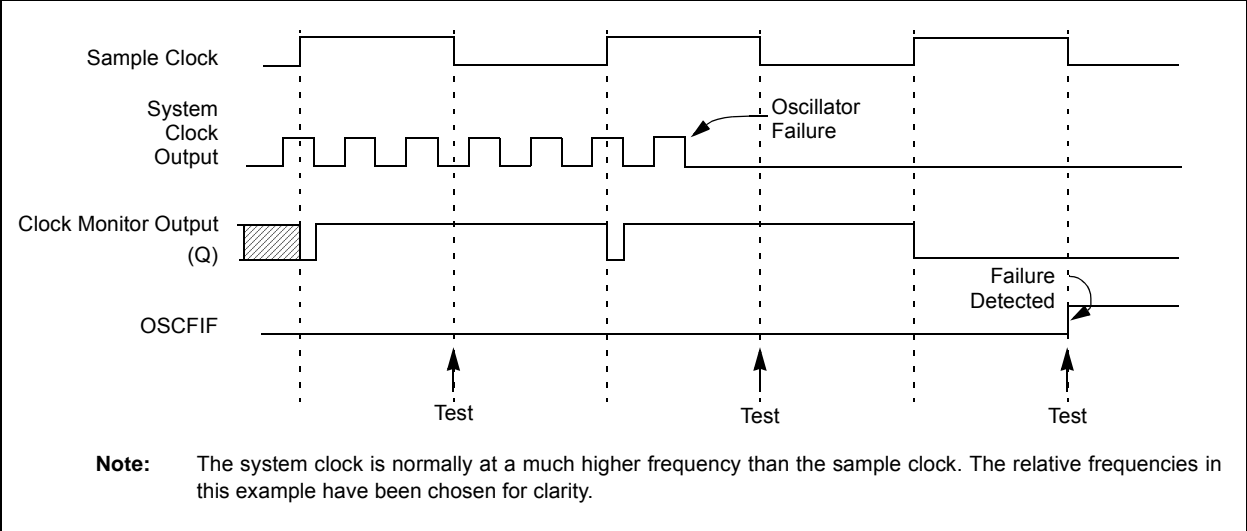
### 6.5.4 RESET OR WAKE-UP FROM SLEEP

The FSCM is designed to detect an oscillator failure after the Oscillator Start-up Timer (OST) has expired. The OST is used after waking up from Sleep and after any type of Reset. The OST is not used with the EC or RC Clock modes so that the FSCM will be active as soon as the Reset or wake-up has completed. When the FSCM is enabled, the Two-Speed Start-up is also enabled. Therefore, the device will always be executing code while the OST is operating.

**Note:** Due to the wide range of oscillator start-up times, the Fail-Safe circuit is not active during oscillator start-up (i.e., after exiting Reset or Sleep). After an appropriate amount of time, the user should check the Status bits in the OSCSTAT register to verify the oscillator start-up and that the system clock switchover has successfully completed.

# PIC16(L)F1717/8/9

FIGURE 6-10: FSCM TIMING DIAGRAM



## 6.6 Register Definitions: Oscillator Control

**REGISTER 6-1: OSCCON: OSCILLATOR CONTROL REGISTER**

R/W-0/0	R/W-0/0	R/W-1/1	R/W-1/1	R/W-1/1	U-0	R/W-0/0	R/W-0/0
SPLLEN	IRCF<3:0>			—	SCS<1:0>		
bit 7							bit 0

**Legend:**

R = Readable bit	W = Writable bit	U = Unimplemented bit, read as '0'
u = Bit is unchanged	x = Bit is unknown	-n/n = Value at POR and BOR/Value at all other Resets
'1' = Bit is set	'0' = Bit is cleared	

- bit 7      **SPLLEN:** Software PLL Enable bit  
If PLEN in Configuration Words = 1:  
 SPLLEN bit is ignored. 4x PLL is always enabled (subject to oscillator requirements)  
If PLEN in Configuration Words = 0:  
 1 = 4x PLL is enabled  
 0 = 4x PLL is disabled
- bit 6-3    **IRCF<3:0>:** Internal Oscillator Frequency Select bits  
 1111 = 16 MHz HF  
 1110 = 8 MHz or 32 MHz HF<sup>(2)</sup>  
 1101 = 4 MHz HF  
 1100 = 2 MHz HF  
 1011 = 1 MHz HF  
 1010 = 500 kHz HF<sup>(1)</sup>  
 1001 = 250 kHz HF<sup>(1)</sup>  
 1000 = 125 kHz HF<sup>(1)</sup>  
 0111 = 500 kHz MF (default upon Reset)  
 0110 = 250 kHz MF  
 0101 = 125 kHz MF  
 0100 = 62.5 kHz MF  
 0011 = 31.25 kHz HF<sup>(1)</sup>  
 0010 = 31.25 kHz MF  
 000x = 31 kHz LF
- bit 2      **Unimplemented:** Read as '0'
- bit 1-0    **SCS<1:0>:** System Clock Select bits  
 1x = Internal oscillator block  
 01 = Secondary oscillator  
 00 = Clock determined by FOSC<2:0> in Configuration Words

- Note 1:** Duplicate frequency derived from HFINTOSC.  
**2:** 32 MHz when SPLLEN bit is set. Refer to [Section 6.2.2.6 “32 MHz Internal Oscillator Frequency Selection”](#).

# PIC16(L)F1717/8/9

## REGISTER 6-2: OSCSTAT: OSCILLATOR STATUS REGISTER

R-1/q	R-0/q	R-q/q	R-0/q	R-0/q	R-q/q	R-0/0	R-0/q
SOSCR	PLL R	OSTS	HFIOFR	HFIOFL	MFIOFR	LFIOFR	HFIOFS
bit 7							bit 0

### Legend:

R = Readable bit	W = Writable bit	U = Unimplemented bit, read as '0'
u = Bit is unchanged	x = Bit is unknown	-n/n = Value at POR and BOR/Value at all other Resets
'1' = Bit is set	'0' = Bit is cleared	q = Conditional

bit 7 **SOSCR**: Secondary Oscillator Ready bit

If T1OSCEEN = 1:

- 1 = Secondary oscillator is ready
- 0 = Secondary oscillator is not ready

If T1OSCEEN = 0:

- 1 = Secondary clock source is always ready

bit 6 **PLL R** 4x PLL Ready bit

- 1 = 4x PLL is ready
- 0 = 4x PLL is not ready

bit 5 **OSTS**: Oscillator Start-up Timer Status bit

- 1 = Running from the clock defined by the FOSC<2:0> bits of the Configuration Words
- 0 = Running from an internal oscillator (FOSC<2:0> = 100)

bit 4 **HFIOFR**: High-Frequency Internal Oscillator Ready bit

- 1 = HFINTOSC is ready
- 0 = HFINTOSC is not ready

bit 3 **HFIOFL**: High-Frequency Internal Oscillator Locked bit

- 1 = HFINTOSC is at least 2% accurate
- 0 = HFINTOSC is not 2% accurate

bit 2 **MFIOFR**: Medium Frequency Internal Oscillator Ready bit

- 1 = MFINTOSC is ready
- 0 = MFINTOSC is not ready

bit 1 **LFIOFR**: Low-Frequency Internal Oscillator Ready bit

- 1 = LFINTOSC is ready
- 0 = LFINTOSC is not ready

bit 0 **HFIOFS**: High-Frequency Internal Oscillator Stable bit

- 1 = HFINTOSC is at least 0.5% accurate
- 0 = HFINTOSC is not 0.5% accurate

# PIC16(L)F1717/8/9

**REGISTER 6-3: OSCTUNE: OSCILLATOR TUNING REGISTER**

U-0	U-0	R/W-0/0	R/W-0/0	R/W-0/0	R/W-0/0	R/W-0/0	R/W-0/0
—	—	TUN<5:0>					
bit 7							bit 0

**Legend:**

R = Readable bit	W = Writable bit	U = Unimplemented bit, read as '0'
u = Bit is unchanged	x = Bit is unknown	-n/n = Value at POR and BOR/Value at all other Resets
'1' = Bit is set	'0' = Bit is cleared	

bit 7-6      **Unimplemented:** Read as '0'

bit 5-0      **TUN<5:0>:** Frequency Tuning bits

100000 = Minimum frequency

•

•

•

111111 =

000000 = Oscillator module is running at the factory-calibrated frequency

000001 =

•

•

•

011110 =

011111 = Maximum frequency

**TABLE 6-2: SUMMARY OF REGISTERS ASSOCIATED WITH CLOCK SOURCES**

Name	Bit 7	Bit 6	Bit 5	Bit 4	Bit 3	Bit 2	Bit 1	Bit 0	Register on Page
OSCCON	SPLLEN	IRCF<3:0>				—	SCS<1:0>		83
OSCSTAT	SOSCR	PLLRC	OSTS	HFIOFR	HFIOFL	MFIOFR	LFIOFR	HFIOFS	84
OSCTUNE	—	—	TUN<5:0>						85
PIR2	OSFIF	C2IF	C1IF	—	BCL1IF	TMR6IF	TMR4IF	CCP2IF	95
PIE2	OSFIE	C2IE	C1IE	—	BCL1IE	TMR6IE	TMR4IE	CCP2IE	92
T1CON	TMR1CS<1:0>		T1CKPS<1:0>		T1OSCEN	T1SYNC	—	TMR1ON	279

**Legend:** — = unimplemented location, read as '0'. Shaded cells are not used by clock sources.

**TABLE 6-3: SUMMARY OF CONFIGURATION WORD WITH CLOCK SOURCES**

Name	Bits	Bit -7	Bit -6	Bit 13/5	Bit 12/4	Bit 11/3	Bit 10/2	Bit 9/1	Bit 8/0	Register on Page
CONFIG1	13:8	—	—	FCMEN	IESO	CLKOUTEN	BOREN<1:0>		—	55
	7:0	CP	MCLRRE	PWRTE	WDTE<1:0>		FOSC<2:0>			

**Legend:** — = unimplemented location, read as '0'. Shaded cells are not used by clock sources.

# PIC16(L)F1717/8/9

## 7.0 INTERRUPTS

The interrupt feature allows certain events to preempt normal program flow. Firmware is used to determine the source of the interrupt and act accordingly. Some interrupts can be configured to wake the MCU from Sleep mode.

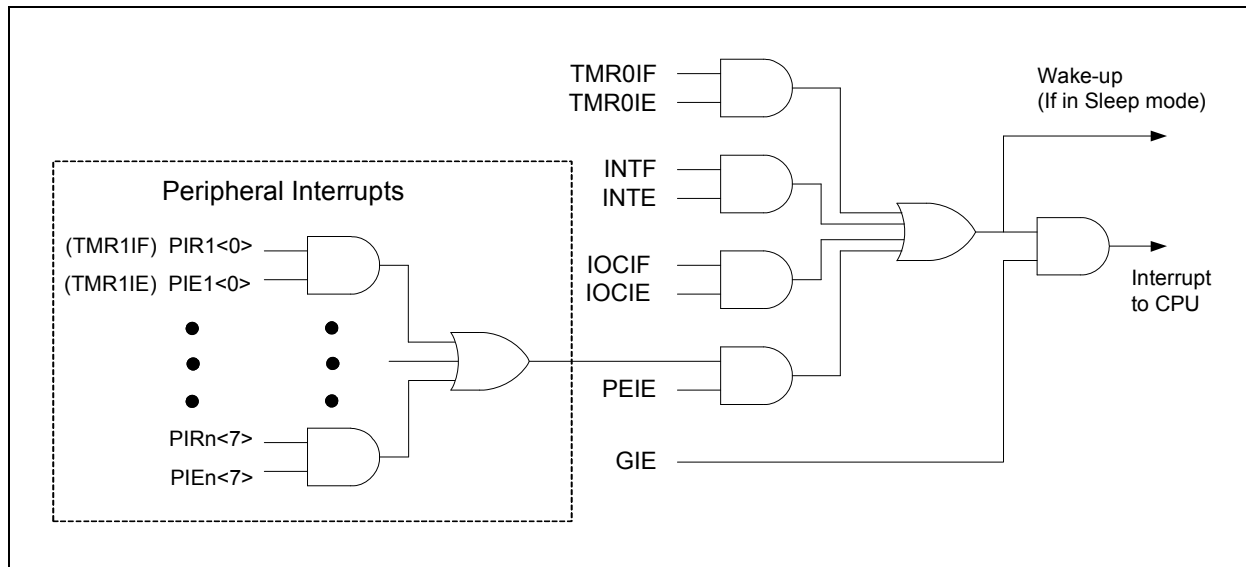
This chapter contains the following information for Interrupts:

- Operation
- Interrupt Latency
- Interrupts During Sleep
- INT Pin
- Automatic Context Saving

Many peripherals produce interrupts. Refer to the corresponding chapters for details.

A block diagram of the interrupt logic is shown in [Figure 7-1](#).

**FIGURE 7-1: INTERRUPT LOGIC**



## 7.1 Operation

Interrupts are disabled upon any device Reset. They are enabled by setting the following bits:

- GIE bit of the INTCON register
- Interrupt Enable bit(s) for the specific interrupt event(s)
- PEIE bit of the INTCON register (if the Interrupt Enable bit of the interrupt event is contained in the PIE1 or PIE2 registers)

The INTCON, PIR1 and PIR2 registers record individual interrupts via interrupt flag bits. Interrupt flag bits will be set, regardless of the status of the GIE, PEIE and individual interrupt enable bits.

The following events happen when an interrupt event occurs while the GIE bit is set:

- Current prefetched instruction is flushed
- GIE bit is cleared
- Current Program Counter (PC) is pushed onto the stack
- Critical registers are automatically saved to the shadow registers (See “[Section 7.5 “Automatic Context Saving”](#)”)
- PC is loaded with the interrupt vector 0004h

The firmware within the Interrupt Service Routine (ISR) should determine the source of the interrupt by polling the interrupt flag bits. The interrupt flag bits must be cleared before exiting the ISR to avoid repeated interrupts. Because the GIE bit is cleared, any interrupt that occurs while executing the ISR will be recorded through its interrupt flag, but will not cause the processor to redirect to the interrupt vector.

The `RETFIE` instruction exits the ISR by popping the previous address from the stack, restoring the saved context from the shadow registers and setting the GIE bit.

For additional information on a specific interrupt's operation, refer to its peripheral chapter.

**Note 1:** Individual interrupt flag bits are set, regardless of the state of any other enable bits.

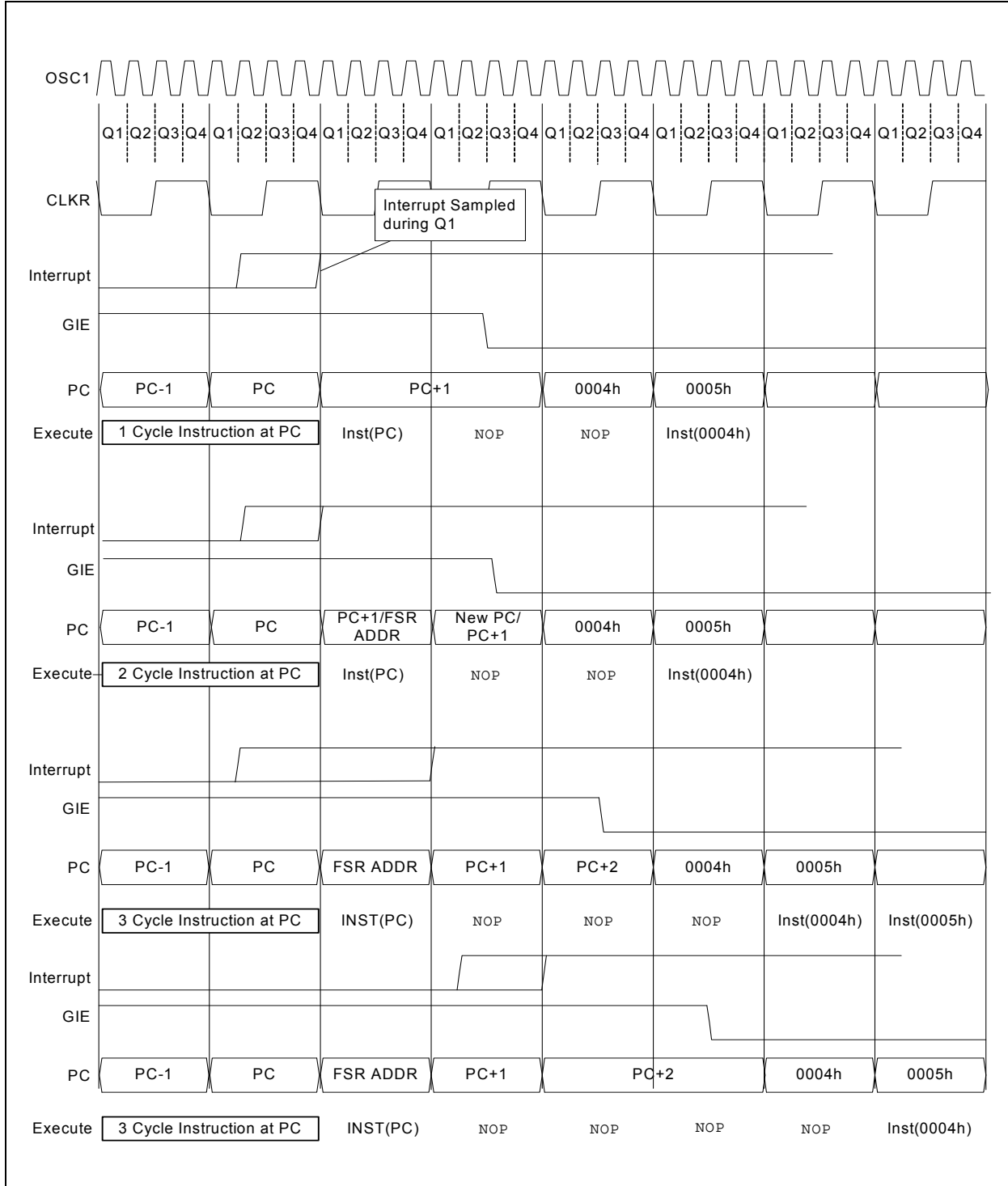
**2:** All interrupts will be ignored while the GIE bit is cleared. Any interrupt occurring while the GIE bit is clear will be serviced when the GIE bit is set again.

## 7.2 Interrupt Latency

Interrupt latency is defined as the time from when the interrupt event occurs to the time code execution at the interrupt vector begins. The latency for synchronous interrupts is three or four instruction cycles. For asynchronous interrupts, the latency is three to five instruction cycles, depending on when the interrupt occurs. See [Figure 7-2](#) and [Figure 7-3](#) for more details.

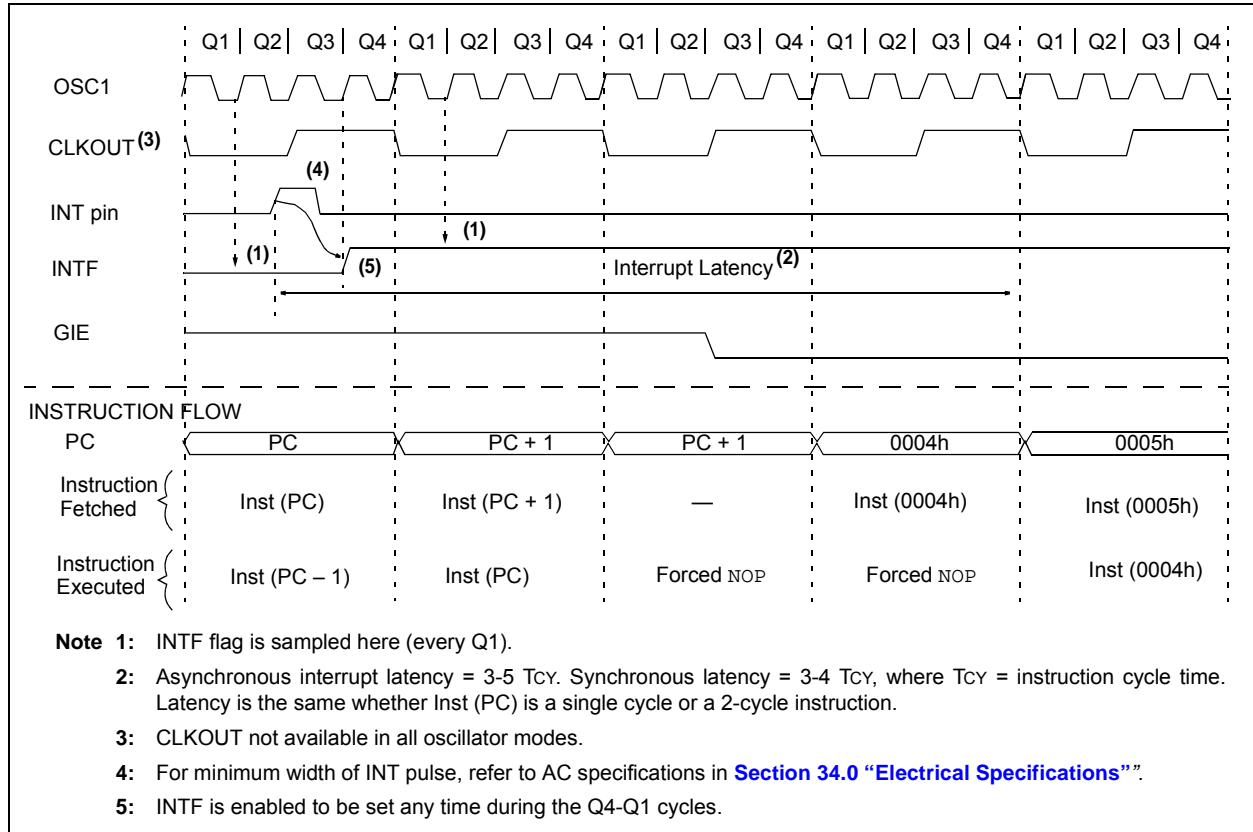
# PIC16(L)F1717/8/9

**FIGURE 7-2: INTERRUPT LATENCY**





**FIGURE 7-3: INT PIN INTERRUPT TIMING**



### 7.3 Interrupts During Sleep

Some interrupts can be used to wake from Sleep. To wake from Sleep, the peripheral must be able to operate without the system clock. The interrupt source must have the appropriate Interrupt Enable bit(s) set prior to entering Sleep.

On waking from Sleep, if the GIE bit is also set, the processor will branch to the interrupt vector. Otherwise, the processor will continue executing instructions after the SLEEP instruction. The instruction directly after the SLEEP instruction will always be executed before branching to the ISR. Refer to [Section 8.0 "Power-Down Mode \(Sleep\)"](#) for more details.

### 7.4 INT Pin

The INT pin can be used to generate an asynchronous edge-triggered interrupt. This interrupt is enabled by setting the INTE bit of the INTCON register. The INTEDG bit of the OPTION\_REG register determines on which edge the interrupt will occur. When the INTEDG bit is set, the rising edge will cause the interrupt. When the INTEDG bit is clear, the falling edge will cause the interrupt. The INTF bit of the INTCON register will be set when a valid edge appears on the INT pin. If the GIE and INTE bits are also set, the processor will redirect program execution to the interrupt vector.

### 7.5 Automatic Context Saving

Upon entering an interrupt, the return PC address is saved on the stack. Additionally, the following registers are automatically saved in the shadow registers:

- W register
- STATUS register (except for  $\overline{TO}$  and  $\overline{PD}$ )
- BSR register
- FSR registers
- PCLATH register

Upon exiting the Interrupt Service Routine, these registers are automatically restored. Any modifications to these registers during the ISR will be lost. If modifications to any of these registers are desired, the corresponding shadow register should be modified and the value will be restored when exiting the ISR. The shadow registers are available in Bank 31 and are readable and writable. Depending on the user's application, other registers may also need to be saved.

# PIC16(L)F1717/8/9

## 7.6 Register Definitions: Interrupt Control

**REGISTER 7-1: INTCON: INTERRUPT CONTROL REGISTER**

R/W-0/0	R/W-0/0	R/W-0/0	R/W-0/0	R/W-0/0	R/W-0/0	R/W-0/0	R-0/0
GIE	PEIE	TMR0IE	INTE	IOCFIE	TMR0IF	INTF	IOCFIF <sup>(1)</sup>
bit 7							bit 0

**Legend:**

R = Readable bit	W = Writable bit	U = Unimplemented bit, read as '0'
u = Bit is unchanged	x = Bit is unknown	-n/n = Value at POR and BOR/Value at all other Resets
'1' = Bit is set	'0' = Bit is cleared	

- bit 7      **GIE:** Global Interrupt Enable bit  
1 = Enables all active interrupts  
0 = Disables all interrupts
- bit 6      **PEIE:** Peripheral Interrupt Enable bit  
1 = Enables all active peripheral interrupts  
0 = Disables all peripheral interrupts
- bit 5      **TMROIE:** Timer0 Overflow Interrupt Enable bit  
1 = Enables the Timer0 interrupt  
0 = Disables the Timer0 interrupt
- bit 4      **INTE:** INT External Interrupt Enable bit  
1 = Enables the INT external interrupt  
0 = Disables the INT external interrupt
- bit 3      **IOCFIE:** Interrupt-on-Change Enable bit  
1 = Enables the interrupt-on-change  
0 = Disables the interrupt-on-change
- bit 2      **TMR0IF:** Timer0 Overflow Interrupt Flag bit  
1 = TMR0 register has overflowed  
0 = TMR0 register did not overflow
- bit 1      **INTF:** INT External Interrupt Flag bit  
1 = The INT external interrupt occurred  
0 = The INT external interrupt did not occur
- bit 0      **IOCFIF:** Interrupt-on-Change Interrupt Flag bit<sup>(1)</sup>  
1 = When at least one of the interrupt-on-change pins changed state  
0 = None of the interrupt-on-change pins have changed state

**Note 1:** The IOCFIF Flag bit is read-only and cleared when all the interrupt-on-change flags in the IOCxF registers have been cleared by software.

**Note:** Interrupt flag bits are set when an interrupt condition occurs, regardless of the state of its corresponding enable bit or the Global Enable bit, GIE, of the INTCON register. User software should ensure the appropriate interrupt flag bits are clear prior to enabling an interrupt.

## REGISTER 7-2: PIE1: PERIPHERAL INTERRUPT ENABLE REGISTER 1

R/W-0/0	R/W-0/0	R/W-0/0	R/W-0/0	R/W-0/0	R/W-0/0	R/W-0/0	R/W-0/0
TMR1GIE	ADIE	RCIE	TXIE	SSP1IE	CCP1IE	TMR2IE	TMR1IE
bit 7							bit 0

### Legend:

R = Readable bit	W = Writable bit	U = Unimplemented bit, read as '0'
u = Bit is unchanged	x = Bit is unknown	-n/n = Value at POR and BOR/Value at all other Resets
'1' = Bit is set	'0' = Bit is cleared	

- bit 7      **TMR1GIE:** Timer1 Gate Interrupt Enable bit  
 1 = Enables the Timer1 gate acquisition interrupt  
 0 = Disables the Timer1 gate acquisition interrupt
- bit 6      **ADIE:** Analog-to-Digital Converter (ADC) Interrupt Enable bit  
 1 = Enables the ADC interrupt  
 0 = Disables the ADC interrupt
- bit 5      **RCIE:** USART Receive Interrupt Enable bit  
 1 = Enables the USART receive interrupt  
 0 = Disables the USART receive interrupt
- bit 4      **TXIE:** USART Transmit Interrupt Enable bit  
 1 = Enables the USART transmit interrupt  
 0 = Disables the USART transmit interrupt
- bit 3      **SSP1IE:** Synchronous Serial Port (MSSP) Interrupt Enable bit  
 1 = Enables the MSSP interrupt  
 0 = Disables the MSSP interrupt
- bit 2      **CCP1IE:** CCP1 Interrupt Enable bit  
 1 = Enables the CCP1 interrupt  
 0 = Disables the CCP1 interrupt
- bit 1      **TMR2IE:** TMR2 to PR2 Match Interrupt Enable bit  
 1 = Enables the Timer2 to PR2 match interrupt  
 0 = Disables the Timer2 to PR2 match interrupt
- bit 0      **TMR1IE:** Timer1 Overflow Interrupt Enable bit  
 1 = Enables the Timer1 overflow interrupt  
 0 = Disables the Timer1 overflow interrupt

**Note:** Bit PEIE of the INTCON register must be set to enable any peripheral interrupt.

# PIC16(L)F1717/8/9

## REGISTER 7-3: PIE2: PERIPHERAL INTERRUPT ENABLE REGISTER 2

R/W-0/0	R/W-0/0	R/W-0/0	U-0	R/W-0/0	R/W-0/0	R/W-0/0	R/W-0/0
OSFIE	C2IE	C1IE	—	BCL1IE	TMR6IE	TMR4IE	CCP2IE
bit 7							bit 0

### Legend:

R = Readable bit

W = Writable bit

U = Unimplemented bit, read as '0'

u = Bit is unchanged

x = Bit is unknown

-n/n = Value at POR and BOR/Value at all other Resets

'1' = Bit is set

'0' = Bit is cleared

- bit 7      **OSFIE:** Oscillator Fail Interrupt Enable bit  
1 = Enables the Oscillator Fail interrupt  
0 = Disables the Oscillator Fail interrupt
- bit 6      **C2IE:** Comparator C2 Interrupt Enable bit  
1 = Enables the Comparator C2 interrupt  
0 = Disables the Comparator C2 interrupt
- bit 5      **C1IE:** Comparator C1 Interrupt Enable bit  
1 = Enables the Comparator C1 interrupt  
0 = Disables the Comparator C1 interrupt
- bit 4      **Unimplemented:** Read as '0'
- bit 3      **BCL1IE:** MSSP Bus Collision Interrupt Enable bit  
1 = Enables the MSSP Bus Collision Interrupt  
0 = Disables the MSSP Bus Collision Interrupt
- bit 2      **TMR6IE:** TMR6 to PR6 Match Interrupt Enable bit  
1 = Enables the Timer6 to PR6 match interrupt  
0 = Disables the Timer6 to PR6 match interrupt
- bit 1      **TMR4IE:** TMR4to PR4 Match Interrupt Enable bit  
1 = Enables the Timer4 to PR4 match interrupt  
0 = Disables the Timer4 to PR4 match interrupt
- bit 0      **CCP2IE:** CCP2 Interrupt Enable bit  
1 = Enables the CCP2 interrupt  
0 = Disables the CCP2 interrupt

**Note:** Bit PEIE of the INTCON register must be set to enable any peripheral interrupt.

## REGISTER 7-4: PIE3: PERIPHERAL INTERRUPT ENABLE REGISTER 3

U-0	R/W-0/0	R/W-0/0	R/W-0/0	R/W-0/0	R/W-0/0	R/W-0/0	R/W-0/0
—	NCOIE	COGIE	ZCDIE	CLC4IE	CLC3IE	CLC2IE	CLC1IE
bit 7							bit 0

### Legend:

R = Readable bit

W = Writable bit

U = Unimplemented bit, read as '0'

u = Bit is unchanged

x = Bit is unknown

-n/n = Value at POR and BOR/Value at all other Resets

'1' = Bit is set

'0' = Bit is cleared

bit 7	<b>Unimplemented:</b> Read as '0'
bit 6	<b>NCOIE:</b> NCO Interrupt Enable bit 1 = NCO interrupt enabled 0 = NCO interrupt disabled
bit 5	<b>COGIE:</b> COG Auto-Shutdown Interrupt Enable bit 1 = COG interrupt enabled 0 = COG interrupt disabled
bit 4	<b>ZCDIE:</b> Zero-Cross Detection Interrupt Enable bit 1 = ZCD interrupt enabled 0 = ZCD interrupt disabled
bit 3	<b>CLC4IE:</b> CLC4 Interrupt Enable bit 1 = CLC4 interrupt enabled 0 = CLC4 interrupt disabled
bit 2	<b>CLC3IE:</b> CLC3 Interrupt Enable bit 1 = CLC3 interrupt enabled 0 = CLC3 interrupt disabled
bit 1	<b>CLC2IE:</b> CLC2 Interrupt Enable bit 1 = CLC2 interrupt enabled 0 = CLC2 interrupt disabled
bit 0	<b>CLC1IE:</b> CLC1 Interrupt Enable bit 1 = CLC1 interrupt enabled 0 = CLC1 interrupt disabled

**Note:** Bit PEIE of the INTCON register must be set to enable any peripheral interrupt.

# PIC16(L)F1717/8/9

## REGISTER 7-5: PIR1: PERIPHERAL INTERRUPT REQUEST REGISTER 1

R/W-0/0	R/W-0/0	R-0/0	R-0/0	R/W-0/0	R/W-0/0	R/W-0/0	R/W-0/0
TMR1GIF	ADIF	RCIF	TXIF	SSP1IF	CCP1IF	TMR2IF	TMR1IF
bit 7							bit 0

### Legend:

R = Readable bit                      W = Writable bit                      U = Unimplemented bit, read as '0'  
u = Bit is unchanged                      x = Bit is unknown                      -n/n = Value at POR and BOR/Value at all other Resets  
'1' = Bit is set                              '0' = Bit is cleared

- bit 7            **TMR1GIF:** Timer1 Gate Interrupt Flag bit  
                  1 = Interrupt is pending  
                  0 = Interrupt is not pending
- bit 6            **ADIF:** Analog-to-Digital Converter (ADC) Interrupt Flag bit  
                  1 = Interrupt is pending  
                  0 = Interrupt is not pending
- bit 5            **RCIF:** USART Receive Interrupt Flag bit  
                  1 = Interrupt is pending  
                  0 = Interrupt is not pending
- bit 4            **TXIF:** USART Transmit Interrupt Flag bit  
                  1 = Interrupt is pending  
                  0 = Interrupt is not pending
- bit 3            **SSP1IF:** Synchronous Serial Port (MSSP) Interrupt Flag bit  
                  1 = Interrupt is pending  
                  0 = Interrupt is not pending
- bit 2            **CCP1IF:** CCP1 Interrupt Flag bit  
                  1 = Interrupt is pending  
                  0 = Interrupt is not pending
- bit 1            **TMR2IF:** Timer2 to PR2 Interrupt Flag bit  
                  1 = Interrupt is pending  
                  0 = Interrupt is not pending
- bit 0            **TMR1IF:** Timer1 Overflow Interrupt Flag bit  
                  1 = Interrupt is pending  
                  0 = Interrupt is not pending

**Note:** Interrupt flag bits are set when an interrupt condition occurs, regardless of the state of its corresponding enable bit or the Global Enable bit, GIE, of the INTCON register. User software should ensure the appropriate interrupt flag bits are clear prior to enabling an interrupt.

## REGISTER 7-6: PIR2: PERIPHERAL INTERRUPT REQUEST REGISTER 2

R/W-0/0	R/W-0/0	R/W-0/0	U-0	R/W-0/0	R/W-0/0	R/W-0/0	R/W-0/0
OSFIF	C2IF	C1IF	—	BCL1IF	TMR6IF	TMR4IF	CCP2IF
bit 7							bit 0

### Legend:

R = Readable bit	W = Writable bit	U = Unimplemented bit, read as '0'
u = Bit is unchanged	x = Bit is unknown	-n/n = Value at POR and BOR/Value at all other Resets
'1' = Bit is set	'0' = Bit is cleared	

bit 7	<b>OSFIF:</b> Oscillator Fail Interrupt Flag bit 1 = Interrupt is pending 0 = Interrupt is not pending
bit 6	<b>C2IF:</b> Comparator C2 Interrupt Flag bit 1 = Interrupt is pending 0 = Interrupt is not pending
bit 5	<b>C1IF:</b> Comparator C1 Interrupt Flag bit 1 = Interrupt is pending 0 = Interrupt is not pending
bit 4	<b>Unimplemented:</b> Read as '0'
bit 3	<b>BCL1IF:</b> MSSP Bus Collision Interrupt Flag bit 1 = Interrupt is pending 0 = Interrupt is not pending
bit 2	<b>TMR6IF:</b> Timer6 to PR6 Interrupt Flag bit 1 = Interrupt is pending 0 = Interrupt is not pending
bit 1	<b>TMR4IF:</b> Timer4 to PR4 Interrupt Flag bit 1 = Interrupt is pending 0 = Interrupt is not pending
bit 0	<b>CCP2IF:</b> CCP2 Interrupt Flag bit 1 = Interrupt is pending 0 = Interrupt is not pending

**Note:** Interrupt flag bits are set when an interrupt condition occurs, regardless of the state of its corresponding enable bit or the Global Enable bit, GIE, of the INTCON register. User software should ensure the appropriate interrupt flag bits are clear prior to enabling an interrupt.

# PIC16(L)F1717/8/9

## REGISTER 7-7: PIR3: PERIPHERAL INTERRUPT REQUEST REGISTER 3

U-0	R/W-0/0	R/W-0/0	R/W-0/0	R/W-0/0	R/W-0/0	R/W-0/0	R/W-0/0
—	NCOIF	COGIF	ZCDIF	CLC4IF	CLC3IF	CLC2IF	CLC1IF
bit 7							bit 0

### Legend:

R = Readable bit

W = Writable bit

U = Unimplemented bit, read as '0'

u = Bit is unchanged

x = Bit is unknown

-n/n = Value at POR and BOR/Value at all other Resets

'1' = Bit is set

'0' = Bit is cleared

- bit 7      **Unimplemented:** Read as '0'
- bit 6      **NCOIF:** NCO Interrupt Flag bit  
1 = Interrupt is pending  
0 = Interrupt is not pending
- bit 5      **COGIF:** COG Auto-Shutdown Interrupt Flag bit  
1 = Interrupt is pending  
0 = Interrupt is not pending
- bit 4      **ZCDIF:** Zero-Cross Detection Interrupt Flag bit  
1 = Interrupt is pending  
0 = Interrupt is not pending
- bit 3      **CLC4IF:** CLC4 Interrupt Flag bit  
1 = Interrupt is pending  
0 = Interrupt is not pending
- bit 2      **CLC3IF:** CLC3 Interrupt Flag bit  
1 = Interrupt is pending  
0 = Interrupt is not pending
- bit 1      **CLC2IF:** CLC2 Interrupt Flag bit  
1 = Interrupt is pending  
0 = Interrupt is not pending
- bit 0      **CLC1IF:** CLC1 Interrupt Flag bit  
1 = Interrupt is pending  
0 = Interrupt is not pending

**Note:** Interrupt flag bits are set when an interrupt condition occurs, regardless of the state of its corresponding enable bit or the Global Enable bit, GIE, of the INTCON register. User software should ensure the appropriate interrupt flag bits are clear prior to enabling an interrupt.



**TABLE 7-1: SUMMARY OF REGISTERS ASSOCIATED WITH INTERRUPTS**

Name	Bit 7	Bit 6	Bit 5	Bit 4	Bit 3	Bit 2	Bit 1	Bit 0	Register on Page
INTCON	GIE	PEIE	TMR0IE	INTE	IOCFIE	TMR0IF	INTF	IOCFIF	<a href="#">90</a>
OPTION_REG	$\overline{\text{WPUEN}}$	INTEDG	TMR0CS	TMR0SE	PSA	PS<2:0>			<a href="#">270</a>
PIE1	TMR1GIE	ADIE	RCIE	TXIE	SSP1IE	CCP1IE	TMR2IE	TMR1IE	<a href="#">91</a>
PIE2	OSFIE	C2IE	C1IE	—	BCL1IE	TMR6IE	TMR4IE	CCP2IE	<a href="#">92</a>
PIE3	—	NCOIE	COGIE	ZCDIE	CLC4IE	CLC3IE	CLC2IE	CLC1IE	<a href="#">93</a>
PIR1	TMR1GIF	ADIF	RCIF	TXIF	SSP1IF	CCP1IF	TMR2IF	TMR1IF	<a href="#">94</a>
PIR2	OSFIF	C2IF	C1IF	—	BCL1IF	TMR6IF	TMR4IF	CCP2IF	<a href="#">95</a>
PIR3	—	NCOIF	COGIF	ZCDIF	CLC4IF	CLC3IF	CLC2IF	CLC1IF	<a href="#">96</a>

**Legend:** — = unimplemented location, read as '0'. Shaded cells are not used by interrupts.

# PIC16(L)F1717/8/9

---

## 8.0 POWER-DOWN MODE (SLEEP)

The Power-down mode is entered by executing a `SLEEP` instruction.

Upon entering Sleep mode, the following conditions exist:

1. WDT will be cleared but keeps running, if enabled for operation during Sleep.
2.  $\overline{PD}$  bit of the STATUS register is cleared.
3.  $\overline{TO}$  bit of the STATUS register is set.
4. CPU clock is disabled.
5. 31 kHz LFINTOSC is unaffected and peripherals that operate from it may continue operation in Sleep.
6. Timer1 and peripherals that operate from Timer1 continue operation in Sleep when the Timer1 clock source selected is:
  - LFINTOSC
  - T1CKI
  - Secondary oscillator
7. ADC is unaffected, if the dedicated FRC oscillator is selected.
8. I/O ports maintain the status they had before `SLEEP` was executed (driving high, low or high-impedance).
9. Resets other than WDT are not affected by Sleep mode.

Refer to individual chapters for more details on peripheral operation during Sleep.

To minimize current consumption, the following conditions should be considered:

- I/O pins should not be floating
- External circuitry sinking current from I/O pins
- Internal circuitry sourcing current from I/O pins
- Current draw from pins with internal weak pull-ups
- Modules using 31 kHz LFINTOSC
- Modules using secondary oscillator

I/O pins that are high-impedance inputs should be pulled to VDD or VSS externally to avoid switching currents caused by floating inputs.

Examples of internal circuitry that might be sourcing current include modules such as the DAC and FVR modules. See [Section 22.0 “Operational Amplifier \(OPA\) Modules”](#) and [Section 14.0 “Fixed Voltage Reference \(FVR\)”](#) for more information on these modules.

## 8.1 Wake-up from Sleep

The device can wake-up from Sleep through one of the following events:

1. External Reset input on  $\overline{MCLR}$  pin, if enabled
2. BOR Reset, if enabled
3. POR Reset
4. Watchdog Timer, if enabled
5. Any external interrupt
6. Interrupts by peripherals capable of running during Sleep (see individual peripheral for more information)

The first three events will cause a device Reset. The last three events are considered a continuation of program execution. To determine whether a device Reset or wake-up event occurred, refer to [Section 5.12 “Determining the Cause of a Reset”](#).

When the `SLEEP` instruction is being executed, the next instruction (PC + 1) is prefetched. For the device to wake-up through an interrupt event, the corresponding interrupt enable bit must be enabled. Wake-up will occur regardless of the state of the GIE bit. If the GIE bit is disabled, the device continues execution at the instruction after the `SLEEP` instruction. If the GIE bit is enabled, the device executes the instruction after the `SLEEP` instruction, the device will then call the Interrupt Service Routine. In cases where the execution of the instruction following `SLEEP` is not desirable, the user should have a `NOP` after the `SLEEP` instruction.

The WDT is cleared when the device wakes up from Sleep, regardless of the source of wake-up.

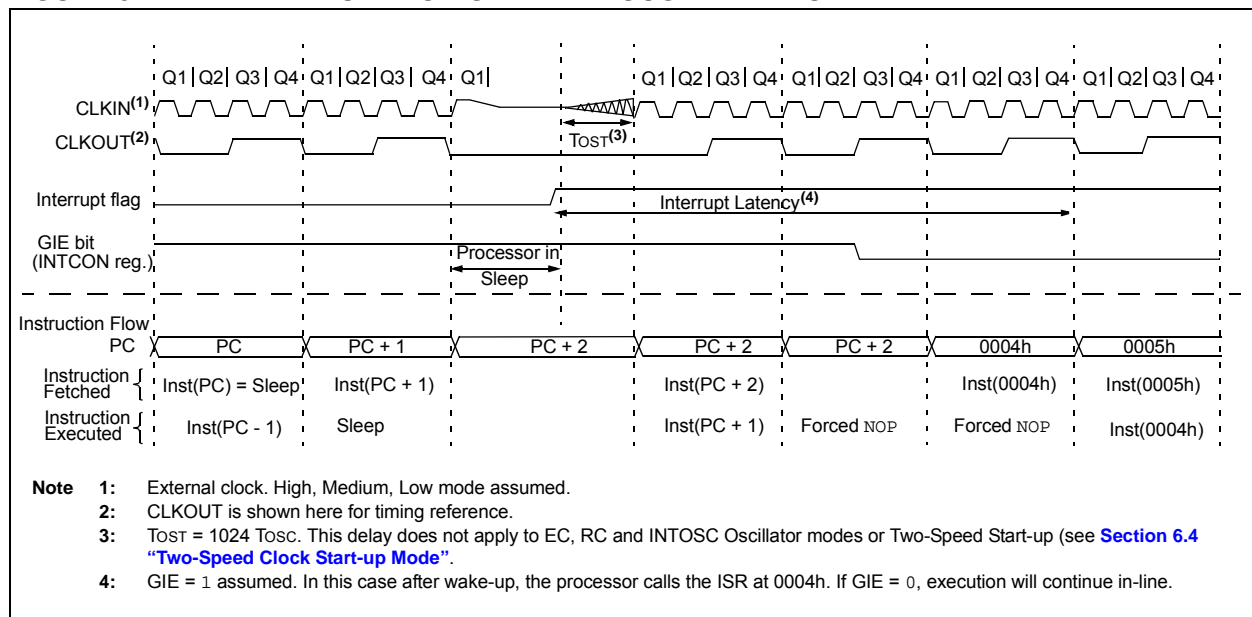
## 8.1.1 WAKE-UP USING INTERRUPTS

When global interrupts are disabled (GIE cleared) and any interrupt source has both its interrupt enable bit and interrupt flag bit set, one of the following will occur:

- If the interrupt occurs **before** the execution of a `SLEEP` instruction
  - `SLEEP` instruction will execute as a `NOP`
  - `WDT` and `WDT` prescaler will not be cleared
  - $\overline{TO}$  bit of the `STATUS` register will not be set
  - $\overline{PD}$  bit of the `STATUS` register will not be cleared
- If the interrupt occurs **during or after** the execution of a `SLEEP` instruction
  - `SLEEP` instruction will be completely executed
  - Device will immediately wake-up from Sleep
  - `WDT` and `WDT` prescaler will be cleared
  - $\overline{TO}$  bit of the `STATUS` register will be set
  - $\overline{PD}$  bit of the `STATUS` register will be cleared

Even if the flag bits were checked before executing a `SLEEP` instruction, it may be possible for flag bits to become set before the `SLEEP` instruction completes. To determine whether a `SLEEP` instruction executed, test the  $\overline{PD}$  bit. If the  $\overline{PD}$  bit is set, the `SLEEP` instruction was executed as a `NOP`.

**FIGURE 8-1: WAKE-UP FROM SLEEP THROUGH INTERRUPT**



# PIC16(L)F1717/8/9

---

## 8.2 Low-Power Sleep Mode

The PIC16F1717/8/9 device contains an internal Low Dropout (LDO) voltage regulator, which allows the device I/O pins to operate at voltages up to 5.5V while the internal device logic operates at a lower voltage. The LDO and its associated reference circuitry must remain active when the device is in Sleep mode. The PIC16F1717/8/9 allows the user to optimize the operating current in Sleep, depending on the application requirements.

A Low-Power Sleep mode can be selected by setting the VREGPM bit of the VREGCON register. With this bit set, the LDO and reference circuitry are placed in a low-power state when the device is in Sleep.

### 8.2.1 SLEEP CURRENT VS. WAKE-UP TIME

In the default operating mode, the LDO and reference circuitry remain in the normal configuration while in Sleep. The device is able to exit Sleep mode quickly since all circuits remain active. In Low-Power Sleep mode, when waking up from Sleep, an extra delay time is required for these circuits to return to the normal configuration and stabilize.

The Low-Power Sleep mode is beneficial for applications that stay in Sleep mode for long periods of time. The Normal mode is beneficial for applications that need to wake from Sleep quickly and frequently.

### 8.2.2 PERIPHERAL USAGE IN SLEEP

Some peripherals that can operate in Sleep mode will not operate properly with the Low-Power Sleep mode selected. The Low-Power Sleep mode is intended for use only with the following peripherals:

- Brown-out Reset (BOR)
- Watchdog Timer (WDT)
- External interrupt pin/Interrupt-on-Change pins
- Timer1 (with external clock source < 100 kHz)

**Note:** The PIC16LF1717/8/9 does not have a configurable Low-Power Sleep mode. PIC16LF1717/8/9 is an unregulated device and is always in the lowest power state when in Sleep, with no wake-up time penalty. This device has a lower maximum V<sub>DD</sub> and I/O voltage than the PIC16F1717/8/9. See [Section 34.0 “Electrical Specifications”](#) for more information.

## 8.3 Register Definitions: Voltage Regulator Control

**REGISTER 8-1: VREGCON: VOLTAGE REGULATOR CONTROL REGISTER<sup>(1)</sup>**

U-0	U-0	U-0	U-0	U-0	U-0	R/W-0/0	R/W-1/1
—	—	—	—	—	—	VREGPM	Reserved
bit 7							bit 0

**Legend:**

R = Readable bit	W = Writable bit	U = Unimplemented bit, read as '0'
u = Bit is unchanged	x = Bit is unknown	-n/n = Value at POR and BOR/Value at all other Resets
'1' = Bit is set	'0' = Bit is cleared	

bit 7-2 **Unimplemented:** Read as '0'

bit 1 **VREGPM:** Voltage Regulator Power Mode Selection bit  
 1 = Low-Power Sleep mode enabled in Sleep<sup>(2)</sup>  
 Draws lowest current in Sleep, slower wake-up  
 0 = Normal-Power mode enabled in Sleep<sup>(2)</sup>  
 Draws higher current in Sleep, faster wake-up

bit 0 **Reserved:** Read as '1'. Maintain this bit set.

**Note 1:** PIC16F1717/8/9 only.

**Note 2:** See [Section 34.0 "Electrical Specifications"](#).

**TABLE 8-1: SUMMARY OF REGISTERS ASSOCIATED WITH POWER-DOWN MODE**

Name	Bit 7	Bit 6	Bit 5	Bit 4	Bit 3	Bit 2	Bit 1	Bit 0	Register on Page
STATUS	—	—	—	$\overline{TO}$	$\overline{PD}$	Z	DC	C	28
VREGCON <sup>(1)</sup>	—	—	—	—	—	—	VREGPM	Reserved	101
WDTCON	—	—	WDTPS<4:0>					SWDTEN	104

**Legend:** — = unimplemented location, read as '0'. Shaded cells are not used in Power-Down mode.

**Note 1:** PIC16F1717/8/9 only.

# PIC16(L)F1717/8/9

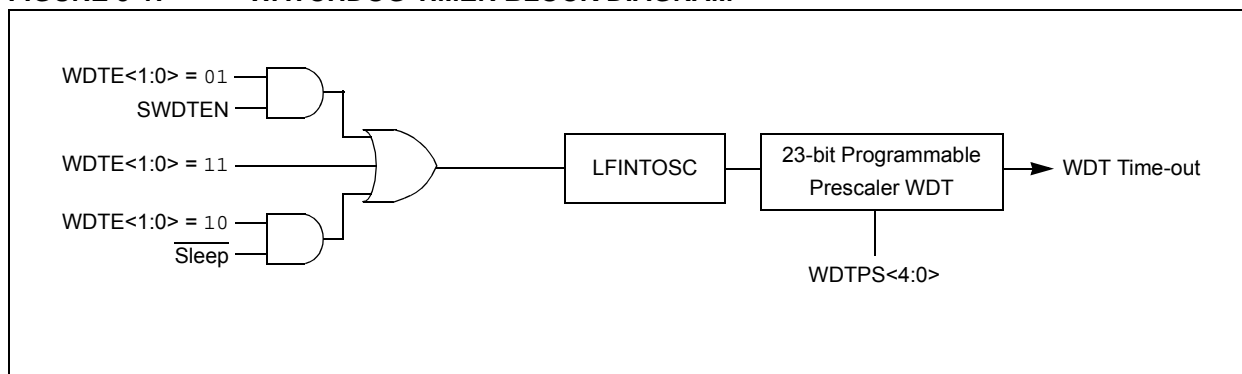
## 9.0 WATCHDOG TIMER (WDT)

The Watchdog Timer is a system timer that generates a Reset if the firmware does not issue a CLRWDT instruction within the time-out period. The Watchdog Timer is typically used to recover the system from unexpected events.

The WDT has the following features:

- Independent clock source
- Multiple operating modes
  - WDT is always on
  - WDT is off when in Sleep
  - WDT is controlled by software
  - WDT is always off
- Configurable time-out period is from 1 ms to 256 seconds (nominal)
- Multiple Reset conditions
- Operation during Sleep

**FIGURE 9-1: WATCHDOG TIMER BLOCK DIAGRAM**



### 9.1 Independent Clock Source

The WDT derives its time base from the 31 kHz LFINTOSC internal oscillator. Time intervals in this chapter are based on a nominal interval of 1 ms. See [Table 34-8: Oscillator Parameters](#) for the LFINTOSC specification.

### 9.2 WDT Operating Modes

The Watchdog Timer module has four operating modes controlled by the WDTE<1:0> bits in Configuration Words. See [Table 9-1](#).

#### 9.2.1 WDT IS ALWAYS ON

When the WDTE bits of Configuration Words are set to '11', the WDT is always on.

WDT protection is active during Sleep.

#### 9.2.2 WDT IS OFF IN SLEEP

When the WDTE bits of Configuration Words are set to '10', the WDT is on, except in Sleep.

WDT protection is not active during Sleep.

#### 9.2.3 WDT CONTROLLED BY SOFTWARE

When the WDTE bits of Configuration Words are set to '01', the WDT is controlled by the SWDTEN bit of the WDTCON register.

WDT protection is unchanged by Sleep. See [Table 9-1](#) for more details.

**TABLE 9-1: WDT OPERATING MODES**

WDTE<1:0>	SWDTEN	Device Mode	WDT Mode
11	X	X	Active
10	X	Awake	Active
		Sleep	Disabled
01	1	X	Active
	0		Disabled
00	X	X	Disabled

## 9.3 Time-out Period

The WDTPS bits of the WDTCON register set the time-out period from 1 ms to 256 seconds (nominal). After a Reset, the default time-out period is two seconds.

## 9.4 Clearing the WDT

The WDT is cleared when any of the following conditions occur:

- Any Reset
- CLRWDT instruction is executed
- Device enters Sleep
- Device wakes up from Sleep
- Oscillator fail
- WDT is disabled
- Oscillator Start-up Timer (OST) is running

See [Table 9-2](#) for more information.

## 9.5 Operation During Sleep

When the device enters Sleep, the WDT is cleared. If the WDT is enabled during Sleep, the WDT resumes counting.

When the device exits Sleep, the WDT is cleared again. The WDT remains clear until the OST, if enabled, completes. See [Section 6.0 “Oscillator Module \(with Fail-Safe Clock Monitor\)”](#) for more information on the OST.

When a WDT time-out occurs while the device is in Sleep, no Reset is generated. Instead, the device wakes up and resumes operation. The  $\overline{TO}$  and  $\overline{PD}$  bits in the STATUS register are changed to indicate the event. See STATUS Register ([Register 3-1](#)) for more information.

**TABLE 9-2: WDT CLEARING CONDITIONS**

Conditions	WDT
WDTE<1:0> = 00	Cleared
WDTE<1:0> = 01 and SWDTEN = 0	
WDTE<1:0> = 10 and enter Sleep	
CLRWDT Command	
Oscillator Fail Detected	
Exit Sleep + System Clock = T1OSC, EXTRC, INTOSC, EXTCLK	Cleared until the end of OST
Exit Sleep + System Clock = XT, HS, LP	Cleared until the end of OST
Change INTOSC divider (IRCF bits)	Unaffected

# PIC16(L)F1717/8/9

## 9.6 Register Definitions: Watchdog Control

**REGISTER 9-1: WDTCON: WATCHDOG TIMER CONTROL REGISTER**

U-0	U-0	R/W-0/0	R/W-1/1	R/W-0/0	R/W-1/1	R/W-1/1	R/W-0/0
—	—	WDTPS<4:0> <sup>(1)</sup>					SWDTEN
bit 7							bit 0

**Legend:**

R = Readable bit	W = Writable bit	U = Unimplemented bit, read as '0'
u = Bit is unchanged	x = Bit is unknown	-m/n = Value at POR and BOR/Value at all other Resets
'1' = Bit is set	'0' = Bit is cleared	

bit 7-6 **Unimplemented:** Read as '0'

bit 5-1 **WDTPS<4:0>:** Watchdog Timer Period Select bits<sup>(1)</sup>

Bit Value = Prescale Rate

11111 = Reserved. Results in minimum interval (1:32)

.

.

.

10011 = Reserved. Results in minimum interval (1:32)

10010 = 1:8388608 ( $2^{23}$ ) (Interval 256s nominal)

10001 = 1:4194304 ( $2^{22}$ ) (Interval 128s nominal)

10000 = 1:2097152 ( $2^{21}$ ) (Interval 64s nominal)

01111 = 1:1048576 ( $2^{20}$ ) (Interval 32s nominal)

01110 = 1:524288 ( $2^{19}$ ) (Interval 16s nominal)

01101 = 1:262144 ( $2^{18}$ ) (Interval 8s nominal)

01100 = 1:131072 ( $2^{17}$ ) (Interval 4s nominal)

01011 = 1:65536 (Interval 2s nominal) (Reset value)

01010 = 1:32768 (Interval 1s nominal)

01001 = 1:16384 (Interval 512 ms nominal)

01000 = 1:8192 (Interval 256 ms nominal)

00111 = 1:4096 (Interval 128 ms nominal)

00110 = 1:2048 (Interval 64 ms nominal)

00101 = 1:1024 (Interval 32 ms nominal)

00100 = 1:512 (Interval 16 ms nominal)

00011 = 1:256 (Interval 8 ms nominal)

00010 = 1:128 (Interval 4 ms nominal)

00001 = 1:64 (Interval 2 ms nominal)

00000 = 1:32 (Interval 1 ms nominal)

bit 0 **SWDTEN:** Software Enable/Disable for Watchdog Timer bit

If WDTE<1:0> = 1x:

This bit is ignored.

If WDTE<1:0> = 01:

1 = WDT is turned on

0 = WDT is turned off

If WDTE<1:0> = 00:

This bit is ignored.

**Note 1:** Times are approximate. WDT time is based on 31 kHz LFINTOSC.



**TABLE 9-3: SUMMARY OF REGISTERS ASSOCIATED WITH WATCHDOG TIMER**

Name	Bit 7	Bit 6	Bit 5	Bit 4	Bit 3	Bit 2	Bit 1	Bit 0	Register on Page
OSCCON	SPLLEN	IRCF<3:0>			—		SCS<1:0>		83
STATUS	—	—	—	$\overline{TO}$	$\overline{PD}$	Z	DC	C	28
WDTCON	—	—	WDTPS<4:0>				SWDTEN		104

**Legend:** x = unknown, u = unchanged, — = unimplemented locations read as '0'. Shaded cells are not used by Watchdog Timer.

**TABLE 9-4: SUMMARY OF CONFIGURATION WORD WITH WATCHDOG TIMER**

Name	Bits	Bit -/7	Bit -/6	Bit 13/5	Bit 12/4	Bit 11/3	Bit 10/2	Bit 9/1	Bit 8/0	Register on Page
CONFIG1	13:8	—	—	FCMEN	IESO	$\overline{CLKOUTEN}$	BOREN<1:0>		—	55
	7:0	$\overline{CP}$	MCLRE	$\overline{PWRTE}$	WDTE<1:0>		FOSC<2:0>			

**Legend:** — = unimplemented location, read as '0'. Shaded cells are not used by Watchdog Timer.

# PIC16(L)F1717/8/9

## 10.0 FLASH PROGRAM MEMORY CONTROL

The Flash program memory is readable and writable during normal operation over the full V<sub>DD</sub> range. Program memory is indirectly addressed using Special Function Registers (SFRs). The SFRs used to access program memory are:

- PMCON1
- PMCON2
- PMDATL
- PMDATH
- PMADRL
- PMADRH

When accessing the program memory, the PMDATH:PMDATL register pair forms a 2-byte word that holds the 14-bit data for read/write, and the PMADRH:PMADRL register pair forms a 2-byte word that holds the 15-bit address of the program memory location being read.

The write time is controlled by an on-chip timer. The write/erase voltages are generated by an on-chip charge pump rated to operate over the operating voltage range of the device.

The Flash program memory can be protected in two ways; by code protection ( $\overline{CP}$  bit in Configuration Words) and write protection (WRT<1:0> bits in Configuration Words).

Code protection ( $\overline{CP} = 0$ )<sup>(1)</sup>, disables access, reading and writing, to the Flash program memory via external device programmers. Code protection does not affect the self-write and erase functionality. Code protection can only be reset by a device programmer performing a Bulk Erase to the device, clearing all Flash program memory, Configuration bits and User IDs.

Write protection prohibits self-write and erase to a portion or all of the Flash program memory as defined by the bits WRT<1:0>. Write protection does not affect a device programmer's ability to read, write or erase the device.

**Note 1:** Code protection of the entire Flash program memory array is enabled by clearing the  $\overline{CP}$  bit of Configuration Words.

## 10.1 PMADRL and PMADRH Registers

The PMADRH:PMADRL register pair can address up to a maximum of 32K words of program memory. When selecting a program address value, the MSB of the address is written to the PMADRH register and the LSB is written to the PMADRL register.

### 10.1.1 PMCON1 AND PMCON2 REGISTERS

PMCON1 is the control register for Flash program memory accesses.

Control bits RD and WR initiate read and write, respectively. These bits cannot be cleared, only set, in software. They are cleared by hardware at completion of the read or write operation. The inability to clear the WR bit in software prevents the accidental, premature termination of a write operation.

The WREN bit, when set, will allow a write operation to occur. On power-up, the WREN bit is clear. The WRERR bit is set when a write operation is interrupted by a Reset during normal operation. In these situations, following Reset, the user can check the WRERR bit and execute the appropriate error handling routine.

The PMCON2 register is a write-only register. Attempting to read the PMCON2 register will return all '0's.

To enable writes to the program memory, a specific pattern (the unlock sequence), must be written to the PMCON2 register. The required unlock sequence prevents inadvertent writes to the program memory write latches and Flash program memory.

## 10.2 Flash Program Memory Overview

It is important to understand the Flash program memory structure for erase and programming operations. Flash program memory is arranged in rows. A row consists of a fixed number of 14-bit program memory words. A row is the minimum size that can be erased by user software.

After a row has been erased, the user can reprogram all or a portion of this row. Data to be written into the program memory row is written to 14-bit wide data write latches. These write latches are not directly accessible to the user, but may be loaded via sequential writes to the PMDATH:PMDATL register pair.

**Note:** If the user wants to modify only a portion of a previously programmed row, then the contents of the entire row must be read and saved in RAM prior to the erase. Then, new data and retained data can be written into the write latches to reprogram the row of Flash program memory. However, any unprogrammed locations can be written without first erasing the row. In this case, it is not necessary to save and rewrite the other previously programmed locations.

See [Table 10-1](#) for Erase Row size and the number of write latches for Flash program memory.

**TABLE 10-1: FLASH MEMORY ORGANIZATION BY DEVICE**

Device	Row Erase (words)	Write Latches (words)
PIC16(L)F1717	32	32
PIC16(L)F1718		
PIC16(L)F1719		

## 10.2.1 READING THE FLASH PROGRAM MEMORY

To read a program memory location, the user must:

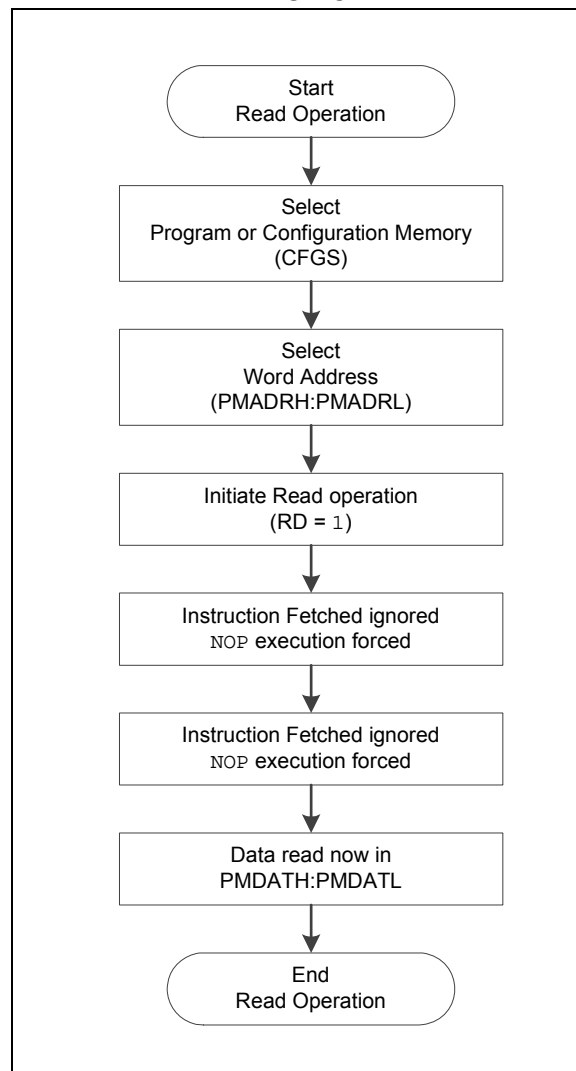
1. Write the desired address to the PMADRH:PMADRL register pair.
2. Clear the CFGS bit of the PMCON1 register.
3. Then, set control bit RD of the PMCON1 register.

Once the read control bit is set, the program memory Flash controller will use the second instruction cycle to read the data. This causes the second instruction immediately following the "BSF PMCON1, RD" instruction to be ignored. The data is available in the very next cycle, in the PMDATH:PMDATL register pair; therefore, it can be read as two bytes in the following instructions.

PMDATH:PMDATL register pair will hold this value until another read or until it is written to by the user.

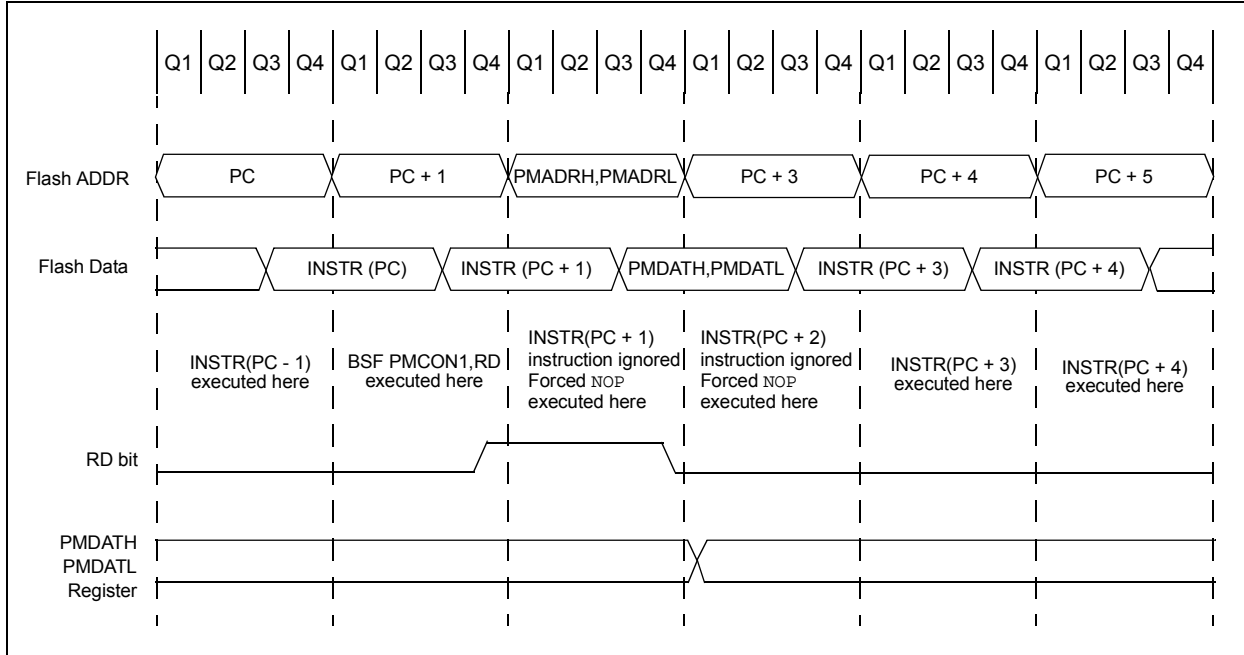
**Note:** The two instructions following a program memory read are required to be NOPs. This prevents the user from executing a 2-cycle instruction on the next instruction after the RD bit is set.

**FIGURE 10-1: FLASH PROGRAM MEMORY READ FLOWCHART**



# PIC16(L)F1717/8/9

**FIGURE 10-2: FLASH PROGRAM MEMORY READ CYCLE EXECUTION**



**EXAMPLE 10-1: FLASH PROGRAM MEMORY READ**

```

* This code block will read 1 word of program
* memory at the memory address:
  PROG_ADDR_HI : PROG_ADDR_LO
* data will be returned in the variables;
*  PROG_DATA_HI, PROG_DATA_LO

  BANKSEL  PMADRL          ; Select Bank for PMCON registers
  MOVLW   PROG_ADDR_LO    ;
  MOVWF   PMADRL          ; Store LSB of address
  MOVLW   PROG_ADDR_HI    ;
  MOVWF   PMADRH          ; Store MSB of address

  BCF     PMCON1,CFGFS     ; Do not select Configuration Space
  BSF     PMCON1,RD        ; Initiate read
  NOP     ; Ignored (Figure 10-1)
  NOP     ; Ignored (Figure 10-1)

  MOVF    PMDATL,W         ; Get LSB of word
  MOVWF   PROG_DATA_LO    ; Store in user location
  MOVF    PMDATH,W         ; Get MSB of word
  MOVWF   PROG_DATA_HI    ; Store in user location

```

## 10.2.2 FLASH MEMORY UNLOCK SEQUENCE

The unlock sequence is a mechanism that protects the Flash program memory from unintended self-write programming or erasing. The sequence must be executed and completed without interruption to successfully complete any of the following operations:

- Row Erase
- Load program memory write latches
- Write of program memory write latches to program memory
- Write of program memory write latches to User IDs

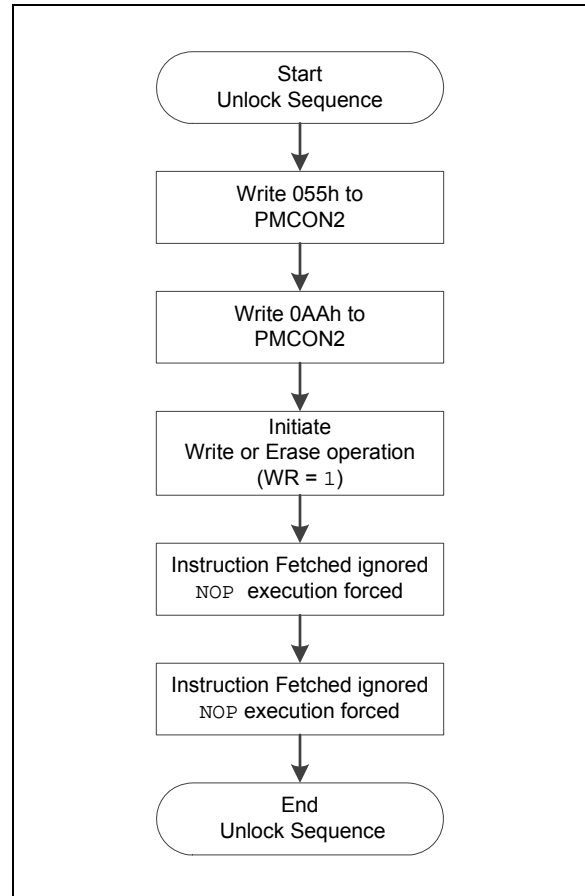
The unlock sequence consists of the following steps:

1. Write 55h to PMCON2
2. Write AAh to PMCON2
3. Set the WR bit in PMCON1
4. NOP instruction
5. NOP instruction

Once the WR bit is set, the processor will always force two NOP instructions. When an Erase Row or Program Row operation is being performed, the processor will stall internal operations (typical 2 ms), until the operation is complete and then resume with the next instruction. When the operation is loading the program memory write latches, the processor will always force the two NOP instructions and continue uninterrupted with the next instruction.

Since the unlock sequence must not be interrupted, global interrupts should be disabled prior to the unlock sequence and re-enabled after the unlock sequence is completed.

**FIGURE 10-3: FLASH PROGRAM MEMORY UNLOCK SEQUENCE FLOWCHART**



# PIC16(L)F1717/8/9

## 10.2.3 ERASING FLASH PROGRAM MEMORY

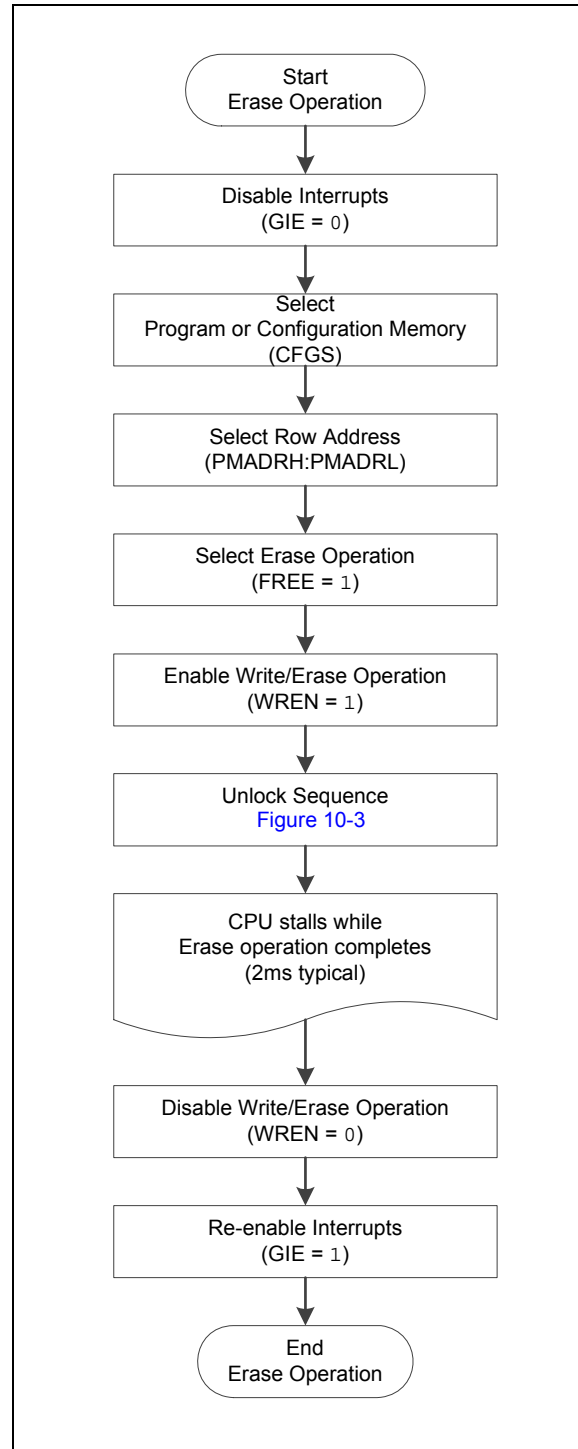
While executing code, program memory can only be erased by rows. To erase a row:

1. Load the PMADRH:PMADRL register pair with any address within the row to be erased.
2. Clear the CFGS bit of the PMCON1 register.
3. Set the FREE and WREN bits of the PMCON1 register.
4. Write 55h, then AAh, to PMCON2 (Flash programming unlock sequence).
5. Set control bit WR of the PMCON1 register to begin the erase operation.

See [Example 10-2](#).

After the “BSF PMCON1, WR” instruction, the processor requires two cycles to set up the erase operation. The user must place two NOP instructions immediately following the WR bit set instruction. The processor will halt internal operations for the typical 2 ms erase time. This is not Sleep mode as the clocks and peripherals will continue to run. After the erase cycle, the processor will resume operation with the third instruction after the PMCON1 write instruction.

**FIGURE 10-4: FLASH PROGRAM MEMORY ERASE FLOWCHART**



## EXAMPLE 10-2: ERASING ONE ROW OF PROGRAM MEMORY

```

; This row erase routine assumes the following:
; 1. A valid address within the erase row is loaded in ADDRH:ADDRL
; 2. ADDRH and ADDRL are located in shared data memory 0x70 - 0x7F (common RAM)

        BCF      INTCON,GIE      ; Disable ints so required sequences will execute properly
        BANKSEL PMADRL
        MOVF     ADDRL,W         ; Load lower 8 bits of erase address boundary
        MOVWF    PMADRL
        MOVF     ADDRH,W        ; Load upper 6 bits of erase address boundary
        MOVWF    PMADRH
        BCF      PMCON1,CFGS     ; Not configuration space
        BSF      PMCON1,FREE     ; Specify an erase operation
        BSF      PMCON1,WREN     ; Enable writes

        MOV LW   55h             ; Start of required sequence to initiate erase
        MOVWF    PMCON2         ; Write 55h
        MOV LW   0AAh           ;
        MOVWF    PMCON2         ; Write AAh
        BSF      PMCON1,WR      ; Set WR bit to begin erase
        NOP
        NOP                     ; NOP instructions are forced as processor starts
        NOP                     ; row erase of program memory.
        ;
        ; The processor stalls until the erase process is complete
        ; after erase processor continues with 3rd instruction

        BCF      PMCON1,WREN     ; Disable writes
        BSF      INTCON,GIE     ; Enable interrupts
    
```

Required Sequence

# PIC16(L)F1717/8/9

## 10.2.4 WRITING TO FLASH PROGRAM MEMORY

Program memory is programmed using the following steps:

1. Load the address in PMADRH:PMADRL of the row to be programmed.
2. Load each write latch with data.
3. Initiate a programming operation.
4. Repeat steps 1 through 3 until all data is written.

Before writing to program memory, the word(s) to be written must be erased or previously unwritten. Program memory can only be erased one row at a time. No automatic erase occurs upon the initiation of the write.

Program memory can be written one or more words at a time. The maximum number of words written at one time is equal to the number of write latches. See [Figure 10-5](#) (row writes to program memory with 32 write latches) for more details.

The write latches are aligned to the Flash row address boundary defined by the upper ten bits of PMADRH:PMADRL, (PMADRH<6:0>:PMADRL<7:5>) with the lower five bits of PMADRL, (PMADRL<4:0>) determining the write latch being loaded. Write operations do not cross these boundaries. At the completion of a program memory write operation, the data in the write latches is reset to contain 0x3FFF.

The following steps should be completed to load the write latches and program a row of program memory. These steps are divided into two parts. First, each write latch is loaded with data from the PMDATH:PMDATL using the unlock sequence with LWLO = 1. When the last word to be loaded into the write latch is ready, the LWLO bit is cleared and the unlock sequence executed. This initiates the programming operation, writing all the latches into Flash program memory.

**Note:** The special unlock sequence is required to load a write latch with data or initiate a Flash programming operation. If the unlock sequence is interrupted, writing to the latches or program memory will not be initiated.

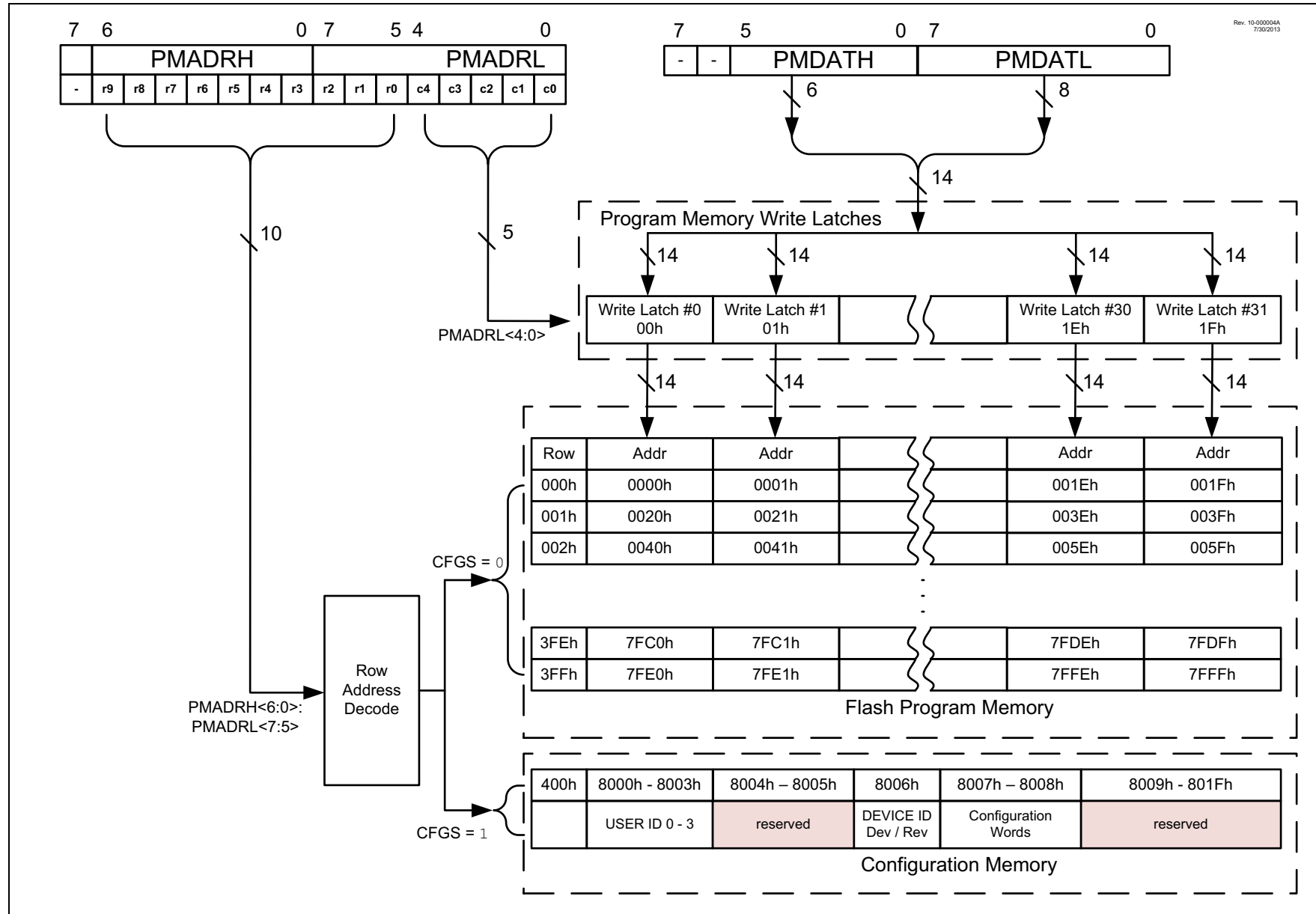
1. Set the WREN bit of the PMCON1 register.
2. Clear the CFGS bit of the PMCON1 register.
3. Set the LWLO bit of the PMCON1 register. When the LWLO bit of the PMCON1 register is '1', the write sequence will only load the write latches and will not initiate the write to Flash program memory.
4. Load the PMADRH:PMADRL register pair with the address of the location to be written.
5. Load the PMDATH:PMDATL register pair with the program memory data to be written.
6. Execute the unlock sequence ([Section 10.2.2 "Flash Memory Unlock Sequence"](#)). The write latch is now loaded.
7. Increment the PMADRH:PMADRL register pair to point to the next location.
8. Repeat steps 5 through 7 until all but the last write latch has been loaded.
9. Clear the LWLO bit of the PMCON1 register. When the LWLO bit of the PMCON1 register is '0', the write sequence will initiate the write to Flash program memory.
10. Load the PMDATH:PMDATL register pair with the program memory data to be written.
11. Execute the unlock sequence ([Section 10.2.2 "Flash Memory Unlock Sequence"](#)). The entire program memory latch content is now written to Flash program memory.

**Note:** The program memory write latches are reset to the blank state (0x3FFF) at the completion of every write or erase operation. As a result, it is not necessary to load all the program memory write latches. Unloaded latches will remain in the blank state.

An example of the complete write sequence is shown in [Example 10-3](#). The initial address is loaded into the PMADRH:PMADRL register pair; the data is loaded using indirect addressing.

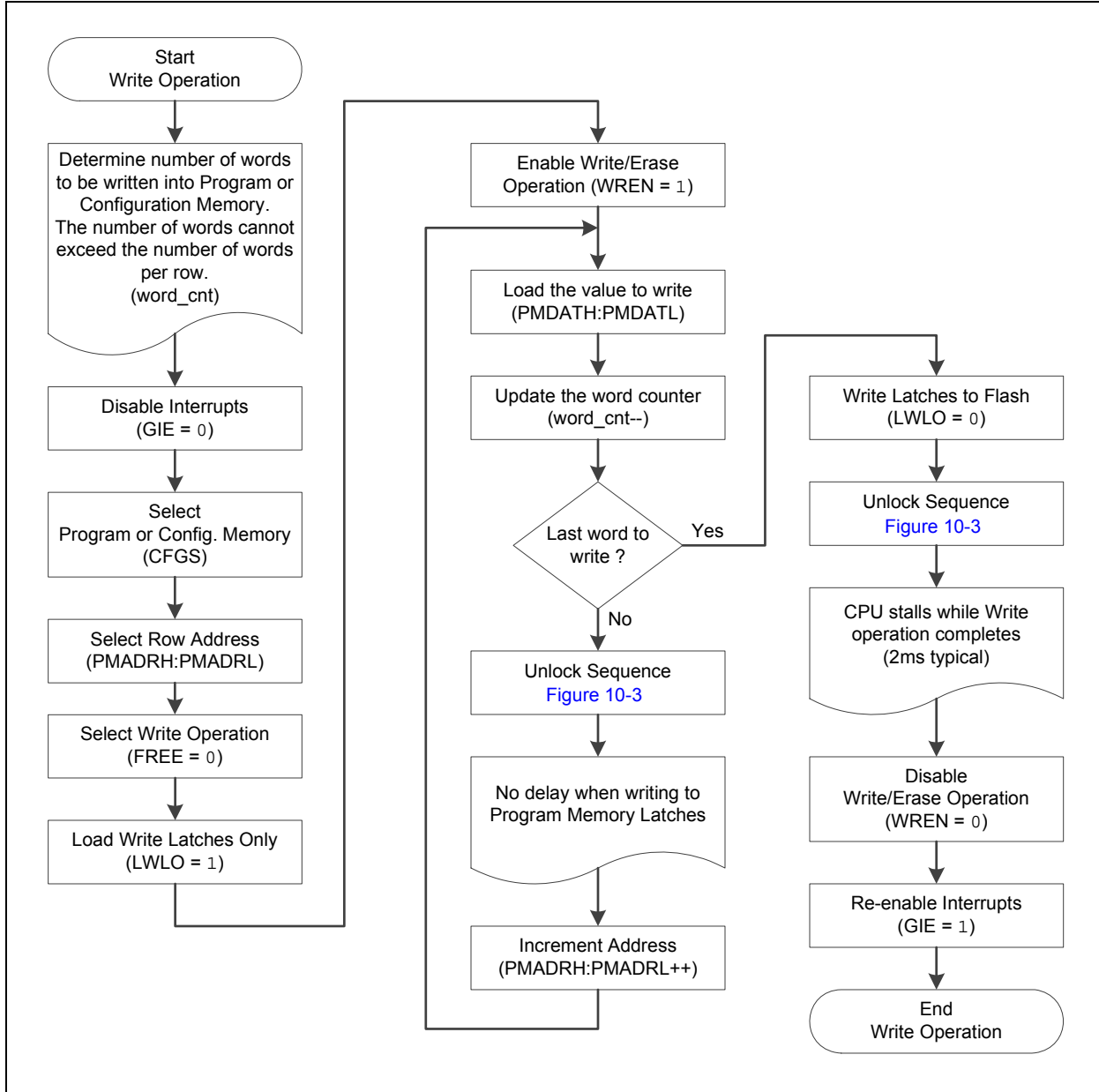


**FIGURE 10-5: BLOCK WRITES TO FLASH PROGRAM MEMORY WITH 32 WRITE LATCHES**



# PIC16(L)F1717/8/9

FIGURE 10-6: FLASH PROGRAM MEMORY WRITE FLOWCHART



## EXAMPLE 10-3: WRITING TO FLASH PROGRAM MEMORY

```

; This write routine assumes the following:
; 1. 64 bytes of data are loaded, starting at the address in DATA_ADDR
; 2. Each word of data to be written is made up of two adjacent bytes in DATA_ADDR,
; stored in little endian format
; 3. A valid starting address (the least significant bits = 00000) is loaded in ADDRH:ADDRL
; 4. ADDRH and ADDRL are located in shared data memory 0x70 - 0x7F (common RAM)
;
        BCF      INTCON,GIE      ; Disable ints so required sequences will execute properly
        BANKSEL  PMADRH         ; Bank 3
        MOVF     ADDRH,W        ; Load initial address
        MOVWF    PMADRH        ;
        MOVF     ADDRL,W        ;
        MOVWF    PMADRL        ;
        MOVLW   LOW DATA_ADDR  ; Load initial data address
        MOVWF    FSR0L         ;
        MOVLW   HIGH DATA_ADDR ; Load initial data address
        MOVWF    FSR0H         ;
        BCF     PMCON1,CFG5     ; Not configuration space
        BSF     PMCON1,WREN     ; Enable writes
        BSF     PMCON1,LWLO     ; Only Load Write Latches

LOOP
        MOVIW   FSR0++         ; Load first data byte into lower
        MOVWF   PMDATL        ;
        MOVIW   FSR0++         ; Load second data byte into upper
        MOVWF   PMDATH        ;

        MOVF    PMADRL,W      ; Check if lower bits of address are '00000'
        XORLW   0x1F         ; Check if we're on the last of 32 addresses
        ANDLW   0x1F         ;
        BTFSC   STATUS,Z      ; Exit if last of 32 words,
        GOTO    START_WRITE   ;

        Required Sequence
        MOVLW   55h           ; Start of required write sequence:
        MOVWF   PMCON2       ; Write 55h
        MOVLW   0AAh         ;
        MOVWF   PMCON2       ; Write AAh
        BSF     PMCON1,WR     ; Set WR bit to begin write
        NOP     ; NOP instructions are forced as processor
                ; loads program memory write latches
        NOP     ;

        INCF    PMADRL,F      ; Still loading latches Increment address
        GOTO    LOOP         ; Write next latches

START_WRITE
        BCF     PMCON1,LWLO   ; No more loading latches - Actually start Flash program
                                ; memory write

        Required Sequence
        MOVLW   55h           ; Start of required write sequence:
        MOVWF   PMCON2       ; Write 55h
        MOVLW   0AAh         ;
        MOVWF   PMCON2       ; Write AAh
        BSF     PMCON1,WR     ; Set WR bit to begin write
        NOP     ; NOP instructions are forced as processor writes
                ; all the program memory write latches simultaneously
                ; to program memory.
        NOP     ; After NOPs, the processor
                ; stalls until the self-write process is complete
                ; after write processor continues with 3rd instruction

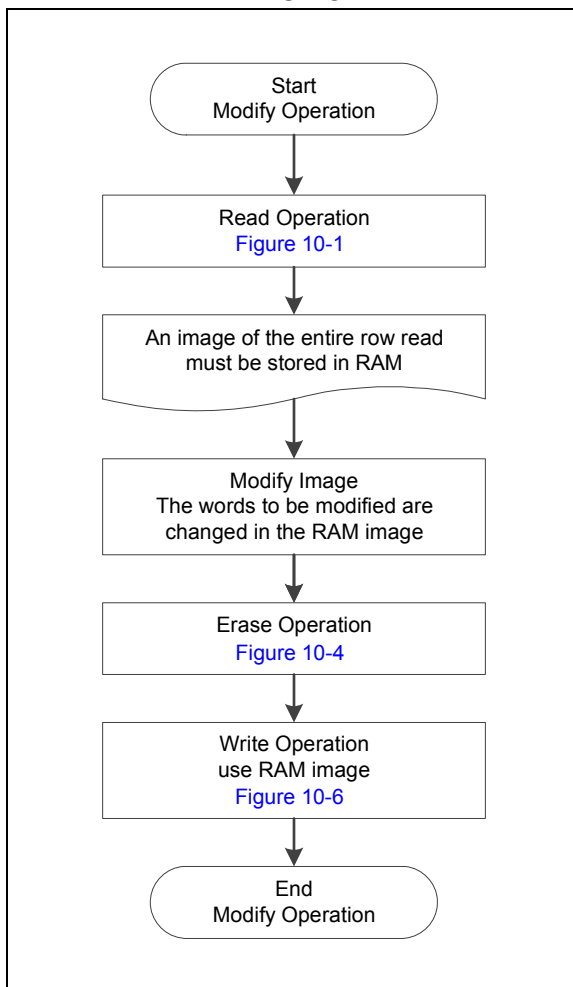
        BCF     PMCON1,WREN   ; Disable writes
        BSF     INTCON,GIE    ; Enable interrupts
    
```

## 10.3 Modifying Flash Program Memory

When modifying existing data in a program memory row, and data within that row must be preserved, it must first be read and saved in a RAM image. Program memory is modified using the following steps:

1. Load the starting address of the row to be modified.
2. Read the existing data from the row into a RAM image.
3. Modify the RAM image to contain the new data to be written into program memory.
4. Load the starting address of the row to be rewritten.
5. Erase the program memory row.
6. Load the write latches with data from the RAM image.
7. Initiate a programming operation.

**FIGURE 10-7: FLASH PROGRAM MEMORY MODIFY FLOWCHART**



## 10.4 User ID, Device ID and Configuration Word Access

Instead of accessing program memory, the User ID's, Device ID/Revision ID and Configuration Words can be accessed when  $CFGS = 1$  in the PMCON1 register. This is the region that would be pointed to by  $PC<15> = 1$ , but not all addresses are accessible. Different access may exist for reads and writes. Refer to [Table 10-2](#).

When read access is initiated on an address outside the parameters listed in [Table 10-2](#), the PMDATH:PMDATL register pair is cleared, reading back '0's.

**TABLE 10-2: USER ID, DEVICE ID AND CONFIGURATION WORD ACCESS (CFGS = 1)**

Address	Function	Read Access	Write Access
8000h-8003h	User IDs	Yes	Yes
8005h-8006h	Device ID/Revision ID	Yes	No
8007h-8008h	Configuration Words 1 and 2	Yes	No

### EXAMPLE 10-4: CONFIGURATION WORD AND DEVICE ID ACCESS

```

* This code block will read 1 word of program memory at the memory address:
*   PROG_ADDR_LO (must be 00h-08h) data will be returned in the variables;
*   PROG_DATA_HI, PROG_DATA_LO

    BANKSEL    PMADRL           ; Select correct Bank
    MOVLW     PROG_ADDR_LO     ;
    MOVWF    PMADRL           ; Store LSB of address
    CLRF     PMADRH           ; Clear MSB of address

    BSF      PMCON1,CFGS       ; Select Configuration Space
    BCF      INTCON,GIE        ; Disable interrupts
    BSF      PMCON1,RD         ; Initiate read
    NOP                                           ; Executed (See Figure 10-2)
    NOP                                           ; Ignored (See Figure 10-2)
    BSF      INTCON,GIE        ; Restore interrupts

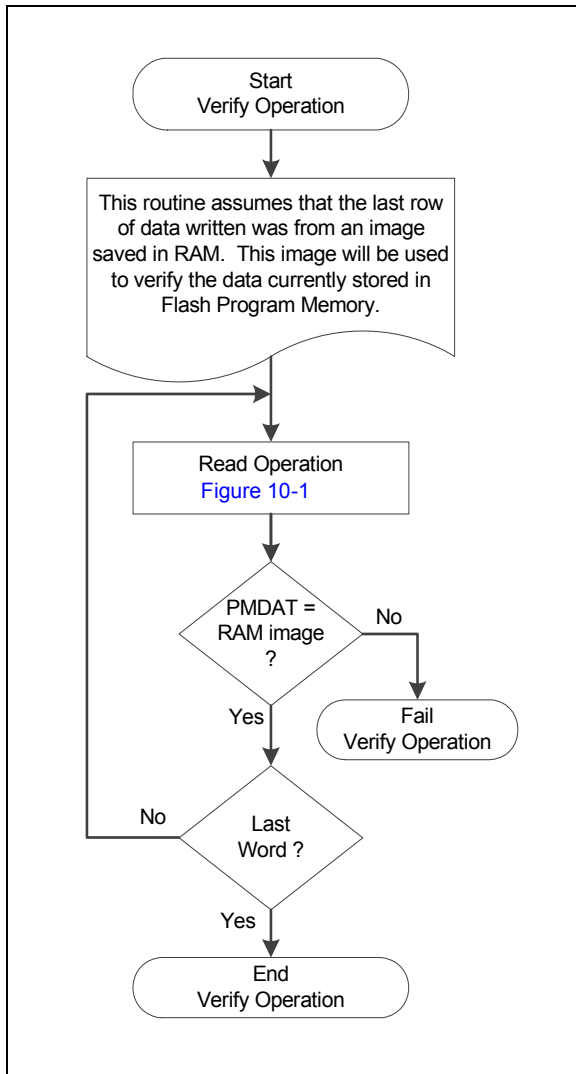
    MOVF     PMDATL,W          ; Get LSB of word
    MOVWF    PROG_DATA_LO     ; Store in user location
    MOVF     PMDATH,W          ; Get MSB of word
    MOVWF    PROG_DATA_HI     ; Store in user location
    
```

# PIC16(L)F1717/8/9

## 10.5 Write Verify

It is considered good programming practice to verify that program memory writes agree with the intended value. Since program memory is stored as a full page then the stored program memory contents are compared with the intended data stored in RAM after the last write is complete.

**FIGURE 10-8: FLASH PROGRAM MEMORY VERIFY FLOWCHART**



## 10.6 Register Definitions: Flash Program Memory Control

### REGISTER 10-1: PMDATL: PROGRAM MEMORY DATA LOW BYTE REGISTER

R/W-x/u	R/W-x/u	R/W-x/u	R/W-x/u	R/W-x/u	R/W-x/u	R/W-x/u	R/W-x/u
PMDAT<7:0>							
bit 7							bit 0

**Legend:**

R = Readable bit	W = Writable bit	U = Unimplemented bit, read as '0'
u = Bit is unchanged	x = Bit is unknown	-n/n = Value at POR and BOR/Value at all other Resets
'1' = Bit is set	'0' = Bit is cleared	

bit 7-0      **PMDAT<7:0>**: Read/write value for Least Significant bits of program memory

### REGISTER 10-2: PMDATH: PROGRAM MEMORY DATA HIGH BYTE REGISTER

U-0	U-0	R/W-x/u	R/W-x/u	R/W-x/u	R/W-x/u	R/W-x/u	R/W-x/u
—		PMDAT<13:8>					
bit 7							bit 0

**Legend:**

R = Readable bit	W = Writable bit	U = Unimplemented bit, read as '0'
u = Bit is unchanged	x = Bit is unknown	-n/n = Value at POR and BOR/Value at all other Resets
'1' = Bit is set	'0' = Bit is cleared	

bit 7-6      **Unimplemented**: Read as '0'

bit 5-0      **PMDAT<13:8>**: Read/write value for Most Significant bits of program memory

### REGISTER 10-3: PMADRL: PROGRAM MEMORY ADDRESS LOW BYTE REGISTER

R/W-0/0	R/W-0/0	R/W-0/0	R/W-0/0	R/W-0/0	R/W-0/0	R/W-0/0	R/W-0/0
PMADR<7:0>							
bit 7							bit 0

**Legend:**

R = Readable bit	W = Writable bit	U = Unimplemented bit, read as '0'
u = Bit is unchanged	x = Bit is unknown	-n/n = Value at POR and BOR/Value at all other Resets
'1' = Bit is set	'0' = Bit is cleared	

bit 7-0      **PMADR<7:0>**: Specifies the Least Significant bits for program memory address

# PIC16(L)F1717/8/9

## REGISTER 10-4: PMADRH: PROGRAM MEMORY ADDRESS HIGH BYTE REGISTER

U-1	R/W-0/0	R/W-0/0	R/W-0/0	R/W-0/0	R/W-0/0	R/W-0/0	R/W-0/0
— <sup>(1)</sup>	PMADR<14:8>						
bit 7							bit 0

### Legend:

R = Readable bit                      W = Writable bit                      U = Unimplemented bit, read as '0'  
u = Bit is unchanged                      x = Bit is unknown                      -n/n = Value at POR and BOR/Value at all other Resets  
'1' = Bit is set                              '0' = Bit is cleared

bit 7                      **Unimplemented:** Read as '1'

bit 6-0                      **PMADR<14:8>:** Specifies the Most Significant bits for program memory address

**Note 1:** Unimplemented, read as '1'.

## REGISTER 10-5: PMCON1: PROGRAM MEMORY CONTROL 1 REGISTER

U-1	R/W-0/0	R/W-0/0	R/W/HC-0/0	R/W/HC-x/q <sup>(2)</sup>	R/W-0/0	R/S/HC-0/0	R/S/HC-0/0
— <sup>(1)</sup>	CFGFS	LWLO <sup>(3)</sup>	FREE	WRERR	WREN	WR	RD
bit 7							bit 0

### Legend:

R = Readable bit                      W = Writable bit                      U = Unimplemented bit, read as '0'  
S = Bit can only be set                      x = Bit is unknown                      -n/n = Value at POR and BOR/Value at all other Resets  
'1' = Bit is set                              '0' = Bit is cleared                      HC = Bit is cleared by hardware

bit 7                      **Unimplemented:** Read as '1'

bit 6                      **CFGFS:** Configuration Select bit  
1 = Access Configuration, User ID and Device ID Registers  
0 = Access Flash program memory

bit 5                      **LWLO:** Load Write Latches Only bit<sup>(3)</sup>  
1 = Only the addressed program memory write latch is loaded/updated on the next WR command  
0 = The addressed program memory write latch is loaded/updated and a write of all program memory write latches will be initiated on the next WR command

bit 4                      **FREE:** Program Flash Erase Enable bit  
1 = Performs an erase operation on the next WR command (hardware cleared upon completion)  
0 = Performs a write operation on the next WR command

bit 3                      **WRERR:** Program/Erase Error Flag bit  
1 = Condition indicates an improper program or erase sequence attempt or termination (bit is set automatically on any set attempt (write '1') of the WR bit).  
0 = The program or erase operation completed normally

bit 2                      **WREN:** Program/Erase Enable bit  
1 = Allows program/erase cycles  
0 = Inhibits programming/erasing of program Flash

bit 1                      **WR:** Write Control bit  
1 = Initiates a program Flash program/erase operation.  
The operation is self-timed and the bit is cleared by hardware once operation is complete.  
The WR bit can only be set (not cleared) in software.  
0 = Program/erase operation to the Flash is complete and inactive

bit 0                      **RD:** Read Control bit  
1 = Initiates a program Flash read. Read takes one cycle. RD is cleared in hardware. The RD bit can only be set (not cleared) in software.  
0 = Does not initiate a program Flash read

**Note 1:** Unimplemented bit, read as '1'.  
**2:** The WRERR bit is automatically set by hardware when a program memory write or erase operation is started (WR = 1).  
**3:** The LWLO bit is ignored during a program memory erase operation (FREE = 1).



**REGISTER 10-6: PMCON2: PROGRAM MEMORY CONTROL 2 REGISTER**

W-0/0	W-0/0	W-0/0	W-0/0	W-0/0	W-0/0	W-0/0	W-0/0
Program Memory Control Register 2							
bit 7				bit 0			

**Legend:**

R = Readable bit	W = Writable bit	U = Unimplemented bit, read as '0'
S = Bit can only be set	x = Bit is unknown	-n/n = Value at POR and BOR/Value at all other Resets
'1' = Bit is set	'0' = Bit is cleared	

bit 7-0

**Flash Memory Unlock Pattern bits**

To unlock writes, a 55h must be written first, followed by an AAh, before setting the WR bit of the PMCON1 register. The value written to this register is used to unlock the writes. There are specific timing requirements on these writes.

**TABLE 10-3: SUMMARY OF REGISTERS ASSOCIATED WITH FLASH PROGRAM MEMORY**

Name	Bit 7	Bit 6	Bit 5	Bit 4	Bit 3	Bit 2	Bit 1	Bit 0	Register on Page
INTCON	GIE	PEIE	TMR0IE	INTE	IOCIE	TMR0IF	INTF	IOCF	90
PMCON1	— <sup>(1)</sup>	CFGS	LWLO	FREE	WRERR	WREN	WR	RD	120
PMCON2	Program Memory Control Register 2								121
PMADRL	PMADRL<7:0>								119
PMADRH	— <sup>(1)</sup>	PMADRH<6:0>							120
PMDATL	PMDATL<7:0>								119
PMDATH	—	—	PMDATH<5:0>					119	

**Legend:** — = unimplemented location, read as '0'. Shaded cells are not used by Flash program memory.

**Note 1:** Unimplemented, read as '1'.

**TABLE 10-4: SUMMARY OF CONFIGURATION WORD WITH FLASH PROGRAM MEMORY**

Name	Bits	Bit -/7	Bit -/6	Bit 13/5	Bit 12/4	Bit 11/3	Bit 10/2	Bit 9/1	Bit 8/0	Register on Page
CONFIG1	13:8	—	—	—	—	CLKOUTEN	BOREN<1:0>		—	55
	7:0	CP	MCLRE	PWRTE	WDTE<1:0>		—	FOSC<1:0>		
CONFIG2	13:8	—	—	LVP	DEBUG	LPBOR	BORV	STVREN	PLEN	57
	7:0	ZCDDIS	—	—	—	—	PPS1WAY	WRT<1:0>		

**Legend:** — = unimplemented location, read as '0'. Shaded cells are not used by Flash program memory.



## 11.1.4 SLEW RATE CONTROL

The SLRCONA register ([Register 11-7](#)) controls the slew rate option for each port pin. Slew rate control is independently selectable for each port pin. When an SLRCONA bit is set, the corresponding port pin drive is slew rate limited. When an SLRCONA bit is cleared, The corresponding port pin drive slews at the maximum rate possible.

## 11.1.5 INPUT THRESHOLD CONTROL

The INLVLA register ([Register 11-8](#)) controls the input voltage threshold for each of the available PORTA input pins. A selection between the Schmitt Trigger CMOS or the TTL compatible thresholds is available. The input threshold is important in determining the value of a read of the PORTA register and also the level at which an interrupt-on-change occurs, if that feature is enabled. See [Table 34-4: I/O Ports](#) for more information on threshold levels.

**Note:** Changing the input threshold selection should be performed while all peripheral modules are disabled. Changing the threshold level during the time a module is active may inadvertently generate a transition associated with an input pin, regardless of the actual voltage level on that pin.

## 11.1.6 ANALOG CONTROL

The ANSELA register ([Register 11-4](#)) is used to configure the Input mode of an I/O pin to analog. Setting the appropriate ANSELA bit high will cause all digital reads on the pin to be read as '0' and allow analog functions on the pin to operate correctly.

The state of the ANSELA bits has no effect on digital output functions. A pin with TRIS clear and ANSEL set will still operate as a digital output, but the Input mode will be analog. This can cause unexpected behavior when executing read-modify-write instructions on the affected port.

**Note:** The ANSELA bits default to the Analog mode after Reset. To use any pins as digital general purpose or peripheral inputs, the corresponding ANSEL bits must be initialized to '0' by user software.

## EXAMPLE 11-1: INITIALIZING PORTA

```
; This code example illustrates
; initializing the PORTA register. The
; other ports are initialized in the same
; manner.

BANKSEL PORTA      ;
CLRF PORTA         ;Init PORTA
BANKSEL LATA       ;Data Latch
CLRF LATA          ;
BANKSEL ANSELA     ;
CLRF ANSELA        ;digital I/O
BANKSEL TRISA      ;
MOVLW B'00111000' ;Set RA<5:3> as inputs
MOVWF TRISA        ;and set RA<2:0> as
                  ;outputs
```

## 11.1.7 PORTA FUNCTIONS AND OUTPUT PRIORITIES

Each PORTA pin is multiplexed with other functions.

Each pin defaults to the PORT latch data after Reset. Other functions are selected with the peripheral pin select logic. See [Section 12.0 "Peripheral Pin Select \(PPS\) Module"](#) for more information.

Analog input functions, such as ADC and comparator inputs are not shown in the peripheral pin select lists. These inputs are active when the I/O pin is set for Analog mode using the ANSELA register. Digital output functions may continue to control the pin when it is in Analog mode.

# PIC16(L)F1717/8/9

## 11.2 Register Definitions: PORTA

### REGISTER 11-1: PORTA: PORTA REGISTER

R/W-x/u	R/W-x/u	R/W-x/u	R/W-x/u	R-x/u	R/W-x/u	R/W-x/u	R/W-x/u
RA7	RA6	RA5	RA4	RA3	RA2	RA1	RA0
bit 7							bit 0

**Legend:**

R = Readable bit                      W = Writable bit                      U = Unimplemented bit, read as '0'  
u = Bit is unchanged                  x = Bit is unknown                  -n/n = Value at POR and BOR/Value at all other Resets  
'1' = Bit is set                          '0' = Bit is cleared

bit 7-0              **RA<7:0>**: PORTA I/O Value bits<sup>(1)</sup>  
1 = Port pin is  $\geq V_{IH}$   
0 = Port pin is  $\leq V_{IL}$

**Note 1:** Writes to PORTA are actually written to corresponding LATA register. Reads from PORTA register is return of actual I/O pin values.

### REGISTER 11-2: TRISA: PORTA TRI-STATE REGISTER

R/W-1/1	R/W-1/1	R/W-1/1	R/W-1/1	R/W-1/1	R/W-1/1	R/W-1/1	R/W-1/1
TRISA7	TRISA6	TRISA5	TRISA4	TRISA3	TRISA2	TRISA1	TRISA0
bit 7							bit 0

**Legend:**

R = Readable bit                      W = Writable bit                      U = Unimplemented bit, read as '0'  
u = Bit is unchanged                  x = Bit is unknown                  -n/n = Value at POR and BOR/Value at all other Resets  
'1' = Bit is set                          '0' = Bit is cleared

bit 7-0              **TRISA<7:0>**: PORTA Tri-State Control bit  
1 = PORTA pin configured as an input (tri-stated)  
0 = PORTA pin configured as an output

## REGISTER 11-3: LATA: PORTA DATA LATCH REGISTER

R/W-x/u	R/W-x/u	R/W-x/u	R/W-x/u	R/W-x/u	R/W-x/u	R/W-x/u	R/W-x/u
LATA7	LATA6	LATA5	LATA4	LATA3	LATA2	LATA1	LATA0
bit 7							bit 0

### Legend:

R = Readable bit                      W = Writable bit                      U = Unimplemented bit, read as '0'  
 u = Bit is unchanged                  x = Bit is unknown                  -n/n = Value at POR and BOR/Value at all other Resets  
 '1' = Bit is set                          '0' = Bit is cleared

bit 7-0                  **LATA<7:0>**: RA<7:0> Output Latch Value bits<sup>(1)</sup>

**Note 1:** Writes to PORTA are actually written to corresponding LATA register. Reads from PORTA register is return of actual I/O pin values.

## REGISTER 11-4: ANSELA: PORTA ANALOG SELECT REGISTER

U-0	U-0	R/W-1/1	R/W-1/1	R/W-1/1	R/W-1/1	R/W-1/1	R/W-1/1
—	—	ANSA5	ANSA4	ANSA3	ANSA2	ANSA1	ANSA0
bit 7							bit 0

### Legend:

R = Readable bit                      W = Writable bit                      U = Unimplemented bit, read as '0'  
 u = Bit is unchanged                  x = Bit is unknown                  -n/n = Value at POR and BOR/Value at all other Resets  
 '1' = Bit is set                          '0' = Bit is cleared

bit 7-6                  **Unimplemented:** Read as '0'

bit 5-0                  **ANSA<5:0>**: Analog Select between Analog or Digital Function on Pins RA<5:0>, respectively  
 1 = Analog input. Pin is assigned as analog input<sup>(1)</sup>. Digital input buffer disabled.  
 0 = Digital I/O. Pin is assigned to port or digital special function.

**Note 1:** When setting a pin to an analog input, the corresponding TRIS bit must be set to Input mode in order to allow external control of the voltage on the pin.

# PIC16(L)F1717/8/9

## REGISTER 11-5: WPUA: WEAK PULL-UP PORTA REGISTER<sup>(1,2)</sup>

R/W-1/1	R/W-1/1	R/W-1/1	R/W-1/1	R/W-1/1	R/W-1/1	R/W-1/1	R/W-1/1
WPUA7	WPUA6	WPUA5	WPUA4	WPUA3	WPUA2	WPUA1	WPUA0
bit 7							bit 0

### Legend:

R = Readable bit                      W = Writable bit                      U = Unimplemented bit, read as '0'  
u = Bit is unchanged                  x = Bit is unknown                  -n/n = Value at POR and BOR/Value at all other Resets  
'1' = Bit is set                          '0' = Bit is cleared

bit 7-0                      **WPUA<7:0>**: Weak Pull-up Register bits  
                                    1 = Pull-up enabled  
                                    0 = Pull-up disabled

- Note 1:** Global  $\overline{\text{WPUEN}}$  bit of the OPTION\_REG register must be cleared for individual pull-ups to be enabled.  
**2:** The weak pull-up device is automatically disabled if the pin is configured as an output.

## REGISTER 11-6: ODCONA: PORTA OPEN-DRAIN CONTROL REGISTER

R/W-0/0	R/W-0/0	R/W-0/0	R/W-0/0	R/W-0/0	R/W-0/0	R/W-0/0	R/W-0/0
ODA7	ODA6	ODA5	ODA4	ODA3	ODA2	ODA1	ODA0
bit 7							bit 0

### Legend:

R = Readable bit                      W = Writable bit                      U = Unimplemented bit, read as '0'  
u = Bit is unchanged                  x = Bit is unknown                  -n/n = Value at POR and BOR/Value at all other Resets  
'1' = Bit is set                          '0' = Bit is cleared

bit 7-0                      **ODA<7:0>**: PORTA Open-Drain Enable bits  
                                    For RA<7:0> pins, respectively  
                                    1 = Port pin operates as open-drain drive (sink current only)  
                                    0 = Port pin operates as standard push-pull drive (source and sink current)

## REGISTER 11-7: SLRCONA: PORTA SLEW RATE CONTROL REGISTER

R/W-1/1	R/W-1/1	R/W-1/1	R/W-1/1	R/W-1/1	R/W-1/1	R/W-1/1	R/W-1/1
SLRA7	SLRA6	SLRA5	SLRA4	SLRA3	SLRA2	SLRA1	SLRA0
bit 7							bit 0

### Legend:

R = Readable bit	W = Writable bit	U = Unimplemented bit, read as '0'
u = Bit is unchanged	x = Bit is unknown	-n/n = Value at POR and BOR/Value at all other Resets
'1' = Bit is set	'0' = Bit is cleared	

bit 7-0      **SLRA<7:0>**: PORTA Slew Rate Enable bits  
 For RA<7:0> pins, respectively  
 1 = Port pin slew rate is limited  
 0 = Port pin slews at maximum rate

## REGISTER 11-8: INLVLA: PORTA INPUT LEVEL CONTROL REGISTER

R/W-0/0	R/W-0/0	R/W-0/0	R/W-0/0	R/W-0/0	R/W-0/0	R/W-0/0	R/W-0/0
INLVLA7	INLVLA6	INLVLA5	INLVLA4	INLVLA3	INLVLA2	INLVLA1	INLVLA0
bit 7							bit 0

### Legend:

R = Readable bit	W = Writable bit	U = Unimplemented bit, read as '0'
u = Bit is unchanged	x = Bit is unknown	-n/n = Value at POR and BOR/Value at all other Resets
'1' = Bit is set	'0' = Bit is cleared	

bit 7-0      **INLVLA<7:0>**: PORTA Input Level Select bits  
 For RA<7:0> pins, respectively  
 1 = Port pin digital input operates with ST thresholds  
 0 = Port pin digital input operates with TTL thresholds

# PIC16(L)F1717/8/9

**TABLE 11-2: SUMMARY OF REGISTERS ASSOCIATED WITH PORTA**

Name	Bit 7	Bit 6	Bit 5	Bit 4	Bit 3	Bit 2	Bit 1	Bit 0	Register on Page
ANSELA	—	—	ANSA5	ANSA4	ANSA3	ANSA2	ANSA1	ANSA0	125
INLVLA	INLVLA7	INLVLA6	INLVLA5	INLVLA4	INLVLA3	INLVLA2	INLVLA1	INLVLA0	127
LATA	LATA7	LATA6	LATA5	LATA4	LATA3	LATA2	LATA1	LATA0	125
ODCONA	ODA7	ODA6	ODA5	ODA4	ODA3	ODA2	ODA1	ODA0	126
OPTION_REG	$\overline{\text{WPUEN}}$	INTEDG	TMR0CS	TMR0SE	PSA	PS<2:0>			270
PORTA	RA7	RA6	RA5	RA4	RA3	RA2	RA1	RA0	124
SLRCONA	SLRA7	SLRA6	SLRA5	SLRA4	SLRA3	SLRA2	SLRA1	SLRA0	127
TRISA	TRISA7	TRISA6	TRISA5	TRISA4	TRISA3	TRISA2	TRISA1	TRISA0	124
WPUA	WPUA7	WPUA6	WPUA5	WPUA4	WPUA3	WPUA2	WPUA1	WPUA0	126

**Legend:** x = unknown, u = unchanged, — = unimplemented locations read as '0'. Shaded cells are not used by PORTA.

**TABLE 11-3: SUMMARY OF CONFIGURATION WORD WITH PORTA**

Name	Bits	Bit -/7	Bit -/6	Bit 13/5	Bit 12/4	Bit 11/3	Bit 10/2	Bit 9/1	Bit 8/0	Register on Page
CONFIG1	13:8	—	—	FCMEN	IESO	$\overline{\text{CLKOUTEN}}$	BOREN<1:0>	—	55	
	7:0	$\overline{\text{CP}}$	MCLRE	$\overline{\text{PWRTÉ}}$	WDTE<1:0>	FOSC<2:0>				

**Legend:** — = unimplemented location, read as '0'. Shaded cells are not used by PORTA.



## 11.3 PORTB Registers

### 11.3.1 DATA REGISTER

PORTB is an 8-bit wide, bidirectional port. The corresponding data direction register is TRISB (Register 11-10). Setting a TRISB bit (= 1) will make the corresponding PORTB pin an input (i.e., put the corresponding output driver in a High-Impedance mode). Clearing a TRISB bit (= 0) will make the corresponding PORTB pin an output (i.e., enable the output driver and put the contents of the output latch on the selected pin). Example 11-1 shows how to initialize an I/O port.

Reading the PORTB register (Register 11-9) reads the status of the pins, whereas writing to it will write to the PORT latch. All write operations are read-modify-write operations. Therefore, a write to a port implies that the port pins are read, this value is modified and then written to the PORT data latch (LATB).

### 11.3.2 DIRECTION CONTROL

The TRISB register (Register 11-10) controls the PORTB pin output drivers, even when they are being used as analog inputs. The user should ensure the bits in the TRISB register are maintained set when using them as analog inputs. I/O pins configured as analog inputs always read '0'.

### 11.3.3 OPEN-DRAIN CONTROL

The ODCONB register (Register 11-14) controls the open-drain feature of the port. Open-drain operation is independently selected for each pin. When an ODCONB bit is set, the corresponding port output becomes an open-drain driver capable of sinking current only. When an ODCONB bit is cleared, the corresponding port output pin is the standard push-pull drive capable of sourcing and sinking current.

### 11.3.4 SLEW RATE CONTROL

The SLRCONB register (Register 11-15) controls the slew rate option for each port pin. Slew rate control is independently selectable for each port pin. When an SLRCONB bit is set, the corresponding port pin drive is slew rate limited. When an SLRCONB bit is cleared, The corresponding port pin drive slews at the maximum rate possible.

### 11.3.5 INPUT THRESHOLD CONTROL

The INLVLB register (Register 11-16) controls the input voltage threshold for each of the available PORTB input pins. A selection between the Schmitt Trigger CMOS or the TTL compatible thresholds is available. The input threshold is important in determining the value of a read of the PORTB register and also the level at which an interrupt-on-change occurs, if that feature is enabled. See Table 34-4: I/O Ports for more information on threshold levels.

**Note:** Changing the input threshold selection should be performed while all peripheral modules are disabled. Changing the threshold level during the time a module is active may inadvertently generate a transition associated with an input pin, regardless of the actual voltage level on that pin.

### 11.3.6 ANALOG CONTROL

The ANSELB register (Register 11-12) is used to configure the Input mode of an I/O pin to analog. Setting the appropriate ANSELB bit high will cause all digital reads on the pin to be read as '0' and allow analog functions on the pin to operate correctly.

The state of the ANSELB bits has no effect on digital output functions. A pin with TRIS clear and ANSELB set will still operate as a digital output, but the Input mode will be analog. This can cause unexpected behavior when executing read-modify-write instructions on the affected port.

**Note:** The ANSELB bits default to the Analog mode after Reset. To use any pins as digital general purpose or peripheral inputs, the corresponding ANSEL bits must be initialized to '0' by user software.

### 11.3.7 PORTB FUNCTIONS AND OUTPUT PRIORITIES

Each pin defaults to the PORT latch data after Reset. Other functions are selected with the peripheral pin select logic. See Section 12.0 "Peripheral Pin Select (PPS) Module" for more information. Analog input functions, such as ADC and op amp inputs, are not shown in the peripheral pin select lists. These inputs are active when the I/O pin is set for Analog mode using the ANSELB register. Digital output functions continue to may continue to control the pin when it is in Analog mode.

# PIC16(L)F1717/8/9

## 11.4 Register Definitions: PORTB

### REGISTER 11-9: PORTB: PORTB REGISTER

R/W-x/u	R/W-x/u	R/W-x/u	R/W-x/u	R/W-x/u	R/W-x/u	R/W-x/u	R/W-x/u
RB7	RB6	RB5	RB4	RB3	RB2	RB1	RB0
bit 7							bit 0

**Legend:**

R = Readable bit                      W = Writable bit                      U = Unimplemented bit, read as '0'  
u = Bit is unchanged                  x = Bit is unknown                      -n/n = Value at POR and BOR/Value at all other Resets  
'1' = Bit is set                          '0' = Bit is cleared

bit 7-0            **RB<7:0>**: PORTB General Purpose I/O Pin bits<sup>(1)</sup>  
1 = Port pin is  $\geq V_{IH}$   
0 = Port pin is  $\leq V_{IL}$

**Note 1:** Writes to PORTB are actually written to corresponding LATB register. Reads from PORTB register is return of actual I/O pin values.

### REGISTER 11-10: TRISB: PORTB TRI-STATE REGISTER

R/W-1/1	R/W-1/1	R/W-1/1	R/W-1/1	R/W-1/1	R/W-1/1	R/W-1/1	R/W-1/1
TRISB7	TRISB6	TRISB5	TRISB4	TRISB3	TRISB2	TRISB1	TRISB0
bit 7							bit 0

**Legend:**

R = Readable bit                      W = Writable bit                      U = Unimplemented bit, read as '0'  
u = Bit is unchanged                  x = Bit is unknown                      -n/n = Value at POR and BOR/Value at all other Resets  
'1' = Bit is set                          '0' = Bit is cleared

bit 7-0            **TRISB<7:0>**: PORTB Tri-State Control bits  
1 = PORTB pin configured as an input (tri-stated)  
0 = PORTB pin configured as an output

### REGISTER 11-11: LATB: PORTB DATA LATCH REGISTER

R/W-x/u	R/W-x/u	R/W-x/u	R/W-x/u	R/W-x/u	R/W-x/u	R/W-x/u	R/W-x/u
LATB7	LATB6	LATB5	LATB4	LATB3	LATB2	LATB1	LATB0
bit 7							bit 0

**Legend:**

R = Readable bit                      W = Writable bit                      U = Unimplemented bit, read as '0'  
u = Bit is unchanged                  x = Bit is unknown                      -n/n = Value at POR and BOR/Value at all other Resets  
'1' = Bit is set                          '0' = Bit is cleared

bit 7-0            **LATB<7:0>**: PORTB Output Latch Value bits<sup>(1)</sup>

**Note 1:** Writes to PORTB are actually written to corresponding LATB register. Reads from PORTB register is return of actual I/O pin values.

## REGISTER 11-12: ANSELB: PORTB ANALOG SELECT REGISTER

U-0	U-0	R/W-1/1	R/W-1/1	R/W-1/1	R/W-1/1	R/W-1/1	R/W-1/1
—	—	ANSB5	ANSB4	ANSB3	ANSB2	ANSB1	ANSB0
bit 7							bit 0

### Legend:

R = Readable bit	W = Writable bit	U = Unimplemented bit, read as '0'
u = Bit is unchanged	x = Bit is unknown	-n/n = Value at POR and BOR/Value at all other Resets
'1' = Bit is set	'0' = Bit is cleared	

bit 7-6      **Unimplemented:** Read as '0'

bit 5-0      **ANSB<5:0>:** Analog Select between Analog or Digital Function on Pins RB<5:0>, respectively  
 0 = Digital I/O. Pin is assigned to port or digital special function.  
 1 = Analog input. Pin is assigned as analog input<sup>(1)</sup>. Digital input buffer disabled.

**Note 1:** When setting a pin to an analog input, the corresponding TRIS bit must be set to Input mode in order to allow external control of the voltage on the pin.

## REGISTER 11-13: WPUB: WEAK PULL-UP PORTB REGISTER<sup>(1,2)</sup>

R/W-1/1	R/W-1/1	R/W-1/1	R/W-1/1	R/W-1/1	R/W-1/1	R/W-1/1	R/W-1/1
WPUB7	WPUB6	WPUB5	WPUB4	WPUB3	WPUB2	WPUB1	WPUB0
bit 7							bit 0

### Legend:

R = Readable bit	W = Writable bit	U = Unimplemented bit, read as '0'
u = Bit is unchanged	x = Bit is unknown	-n/n = Value at POR and BOR/Value at all other Resets
'1' = Bit is set	'0' = Bit is cleared	

bit 7-0      **WPUB<7:0>:** Weak Pull-up Register bits  
 1 = Pull-up enabled  
 0 = Pull-up disabled

**Note 1:** Global  $\overline{\text{WPUEN}}$  bit of the OPTION\_REG register must be cleared for individual pull-ups to be enabled.

**Note 2:** The weak pull-up device is automatically disabled if the pin is configured as an output.

# PIC16(L)F1717/8/9

## REGISTER 11-14: ODCONB: PORTB OPEN-DRAIN CONTROL REGISTER

R/W-0/0	R/W-0/0	R/W-0/0	R/W-0/0	R/W-0/0	R/W-0/0	R/W-0/0	R/W-0/0
ODB7	ODB6	ODB5	ODB4	ODB3	ODB2	ODB1	ODB0
bit 7							bit 0

### Legend:

R = Readable bit                      W = Writable bit                      U = Unimplemented bit, read as '0'  
u = Bit is unchanged                  x = Bit is unknown                      -n/n = Value at POR and BOR/Value at all other Resets  
'1' = Bit is set                          '0' = Bit is cleared

bit 7-0                      **ODB<7:0>**: PORTB Open-Drain Enable bits  
For RB<7:0> pins, respectively  
1 = Port pin operates as open-drain drive (sink current only)  
0 = Port pin operates as standard push-pull drive (source and sink current)

## REGISTER 11-15: SLRCONB: PORTB SLEW RATE CONTROL REGISTER

R/W-1/1	R/W-1/1	R/W-1/1	R/W-1/1	R/W-1/1	R/W-1/1	R/W-1/1	R/W-1/1
SLRB7	SLRB6	SLRB5	SLRB4	SLRB3	SLRB2	SLRB1	SLRB0
bit 7							bit 0

### Legend:

R = Readable bit                      W = Writable bit                      U = Unimplemented bit, read as '0'  
u = Bit is unchanged                  x = Bit is unknown                      -n/n = Value at POR and BOR/Value at all other Resets  
'1' = Bit is set                          '0' = Bit is cleared

bit 7-0                      **SLRB<7:0>**: PORTB Slew Rate Enable bits  
For RB<7:0> pins, respectively  
1 = Port pin slew rate is limited  
0 = Port pin slews at maximum rate

## REGISTER 11-16: INLVLB: PORTB INPUT LEVEL CONTROL REGISTER

R/W-0/0	R/W-0/0	R/W-0/0	R/W-0/0	R/W-0/0	R/W-0/0	R/W-0/0	R/W-0/0
INLVLB7	INLVLB6	INLVLB5	INLVLB4	INLVLB3	INLVLB2	INLVLB1	INLVLB0
bit 7							bit 0

### Legend:

R = Readable bit                      W = Writable bit                      U = Unimplemented bit, read as '0'  
u = Bit is unchanged                  x = Bit is unknown                      -n/n = Value at POR and BOR/Value at all other Resets  
'1' = Bit is set                          '0' = Bit is cleared

bit 7-0                      **INLVLB<7:0>**: PORTB Input Level Select bits  
For RB<7:0> pins, respectively  
1 = Port pin digital input operates with ST thresholds  
0 = Port pin digital input operates with TTL thresholds

**TABLE 11-4: SUMMARY OF REGISTERS ASSOCIATED WITH PORTB**

Name	Bit 7	Bit 6	Bit 5	Bit 4	Bit 3	Bit 2	Bit 1	Bit 0	Register on Page
ANSELB	—	—	ANSB5	ANSB4	ANSB3	ANSB2	ANSB1	ANSB0	<a href="#">131</a>
INLVLB	INLVLB7	INLVLB6	INLVLB5	INLVLB4	INLVLB3	INLVLB2	INLVLB1	INLVLB0	<a href="#">132</a>
LATB	LATB7	LATB6	LATB5	LATB4	LATB3	LATB2	LATB1	LATB0	<a href="#">130</a>
ODCONB	ODB7	ODB6	ODB5	ODB4	ODB3	ODB2	ODB1	ODB0	<a href="#">132</a>
PORTB	RB7	RB6	RB5	RB4	RB3	RB2	RB1	RB0	<a href="#">130</a>
SLRCONB	SLRB7	SLRB6	SLRB5	SLRB4	SLRB3	SLRB2	SLRB1	SLRB0	<a href="#">132</a>
TRISB	TRISB7	TRISB6	TRISB5	TRISB4	TRISB3	TRISB2	TRISB1	TRISB0	<a href="#">130</a>
WPUB	WPUB7	WPUB6	WPUB5	WPUB4	WPUB3	WPUB2	WPUB1	WPUB0	<a href="#">131</a>

**Legend:** x = unknown, u = unchanged, - = unimplemented locations read as '0'. Shaded cells are not used by PORTB.

# PIC16(L)F1717/8/9

## 11.5 PORTC Registers

### 11.5.1 DATA REGISTER

PORTC is an 8-bit wide bidirectional port. The corresponding data direction register is TRISC (Register 11-18). Setting a TRISC bit (= 1) will make the corresponding PORTC pin an input (i.e., put the corresponding output driver in a High-Impedance mode). Clearing a TRISC bit (= 0) will make the corresponding PORTC pin an output (i.e., enable the output driver and put the contents of the output latch on the selected pin). Example 11-1 shows how to initialize an I/O port.

Reading the PORTC register (Register 11-17) reads the status of the pins, whereas writing to it will write to the PORT latch. All write operations are read-modify-write operations. Therefore, a write to a port implies that the port pins are read, this value is modified and then written to the PORT data latch (LATC).

### 11.5.2 DIRECTION CONTROL

The TRISC register (Register 11-18) controls the PORTC pin output drivers, even when they are being used as analog inputs. The user should ensure the bits in the TRISC register are maintained set when using them as analog inputs. I/O pins configured as analog inputs always read '0'.

### 11.5.3 INPUT THRESHOLD CONTROL

The INLVLC register (Register 11-24) controls the input voltage threshold for each of the available PORTC input pins. A selection between the Schmitt Trigger CMOS or the TTL compatible thresholds is available. The input threshold is important in determining the value of a read of the PORTC register and also the level at which an interrupt-on-change occurs, if that feature is enabled. See Table 34-4: I/O Ports for more information on threshold levels.

**Note:** Changing the input threshold selection should be performed while all peripheral modules are disabled. Changing the threshold level during the time a module is active may inadvertently generate a transition associated with an input pin, regardless of the actual voltage level on that pin.

### 11.5.4 OPEN-DRAIN CONTROL

The ODCONC register (Register 11-22) controls the open-drain feature of the port. Open-drain operation is independently selected for each pin. When an ODCONC bit is set, the corresponding port output becomes an open-drain driver capable of sinking current only. When an ODCONC bit is cleared, the corresponding port output pin is the standard push-pull drive capable of sourcing and sinking current.

### 11.5.5 SLEW RATE CONTROL

The SLRCONC register (Register 11-23) controls the slew rate option for each port pin. Slew rate control is independently selectable for each port pin. When an SLRCONC bit is set, the corresponding port pin drive is slew rate limited. When an SLRCONC bit is cleared, the corresponding port pin drive slews at the maximum rate possible.

### 11.5.6 ANALOG CONTROL

The ANSEL register (Register 11-20) is used to configure the Input mode of an I/O pin to analog. Setting the appropriate ANSEL bit high will cause all digital reads on the pin to be read as '0' and allow analog functions on the pin to operate correctly.

The state of the ANSEL bits has no effect on digital output functions. A pin with TRIS clear and ANSEL set will still operate as a digital output, but the Input mode will be analog. This can cause unexpected behavior when executing read-modify-write instructions on the affected port.

**Note:** The ANSEL bits default to the Analog mode after Reset. To use any pins as digital general purpose or peripheral inputs, the corresponding ANSEL bits must be initialized to '0' by user software.

### 11.5.7 PORTC FUNCTIONS AND OUTPUT PRIORITIES

Each pin defaults to the PORT latch data after Reset. Other functions are selected with the peripheral pin select logic. See Section 12.0 "Peripheral Pin Select (PPS) Module" for more information.

Analog input functions, such as ADC and comparator inputs, are not shown in the peripheral pin select lists. These inputs are active when the I/O pin is set for Analog mode using the ANSEL register. Digital output functions may continue to control the pin when it is in Analog mode.

## 11.6 Register Definitions: PORTC

### REGISTER 11-17: PORTC: PORTC REGISTER

R/W-x/u	R/W-x/u	R/W-x/u	R/W-x/u	R/W-x/u	R/W-x/u	R/W-x/u	R/W-x/u
RC7	RC6	RC5	RC4	RC3	RC2	RC1	RC0
bit 7							bit 0

#### Legend:

R = Readable bit                      W = Writable bit                      U = Unimplemented bit, read as '0'  
u = Bit is unchanged                  x = Bit is unknown                  -n/n = Value at POR and BOR/Value at all other Resets  
'1' = Bit is set                          '0' = Bit is cleared

bit 7-0              **RC<7:0>**: PORTC General Purpose I/O Pin bits<sup>(1)</sup>  
1 = Port pin is  $\geq$  VIH  
0 = Port pin is  $\leq$  VIL

**Note 1:** Writes to PORTC are actually written to corresponding LATC register. Reads from PORTC register is return of actual I/O pin values.

### REGISTER 11-18: TRISC: PORTC TRI-STATE REGISTER

R/W-1/1	R/W-1/1	R/W-1/1	R/W-1/1	R/W-1/1	R/W-1/1	R/W-1/1	R/W-1/1
TRISC7	TRISC6	TRISC5	TRISC4	TRISC3	TRISC2	TRISC1	TRISC0
bit 7							bit 0

#### Legend:

R = Readable bit                      W = Writable bit                      U = Unimplemented bit, read as '0'  
u = Bit is unchanged                  x = Bit is unknown                  -n/n = Value at POR and BOR/Value at all other Resets  
'1' = Bit is set                          '0' = Bit is cleared

bit 7-0              **TRISC<7:0>**: PORTC Tri-State Control bits  
1 = PORTC pin configured as an input (tri-stated)  
0 = PORTC pin configured as an output

### REGISTER 11-19: LATC: PORTC DATA LATCH REGISTER

R/W-x/u	R/W-x/u	R/W-x/u	R/W-x/u	R/W-x/u	R/W-x/u	R/W-x/u	R/W-x/u
LATC7	LATC6	LATC5	LATC4	LATC3	LATC2	LATC1	LATC0
bit 7							bit 0

#### Legend:

R = Readable bit                      W = Writable bit                      U = Unimplemented bit, read as '0'  
u = Bit is unchanged                  x = Bit is unknown                  -n/n = Value at POR and BOR/Value at all other Resets  
'1' = Bit is set                          '0' = Bit is cleared

bit 7-0              **LATC<7:0>**: PORTC Output Latch Value bits

# PIC16(L)F1717/8/9

## REGISTER 11-20: ANSELC: PORTC ANALOG SELECT REGISTER

R/W-1/1	R/W-1/1	R/W-1/1	R/W-1/1	R/W-1/1	R/W-1/1	U-0	U-0
ANSC7	ANSC6	ANSC5	ANSC4	ANSC3	ANSC2	—	—
bit 7						bit 0	

### Legend:

R = Readable bit                      W = Writable bit                      U = Unimplemented bit, read as '0'  
u = Bit is unchanged                  x = Bit is unknown                  -n/n = Value at POR and BOR/Value at all other Resets  
'1' = Bit is set                            '0' = Bit is cleared

bit 7-2            **ANSC<7:2>**: Analog Select between Analog or Digital Function on Pins RC<7:2>, respectively<sup>(1)</sup>  
0 = Digital I/O. Pin is assigned to port or digital special function.  
1 = Analog input. Pin is assigned as analog input<sup>(1)</sup>. Digital input buffer disabled.

bit 1-0            **Unimplemented**: Read as '0'

**Note 1:** When setting a pin to an analog input, the corresponding TRIS bit must be set to Input mode in order to allow external control of the voltage on the pin.

## REGISTER 11-21: WPUC: WEAK PULL-UP PORTC REGISTER<sup>(1,2)</sup>

R/W-1/1	R/W-1/1	R/W-1/1	R/W-1/1	R/W-1/1	R/W-1/1	R/W-1/1	R/W-1/1
WPUC7	WPUC6	WPUC5	WPUC4	WPUC3	WPUC2	WPUC1	WPUC0
bit 7						bit 0	

### Legend:

R = Readable bit                      W = Writable bit                      U = Unimplemented bit, read as '0'  
u = Bit is unchanged                  x = Bit is unknown                  -n/n = Value at POR and BOR/Value at all other Resets  
'1' = Bit is set                            '0' = Bit is cleared

bit 7-0            **WPUC<7:0>**: Weak Pull-up Register bits  
1 = Pull-up enabled  
0 = Pull-up disabled

**Note 1:** Global  $\overline{\text{WPUEN}}$  bit of the OPTION\_REG register must be cleared for individual pull-ups to be enabled.  
**2:** The weak pull-up device is automatically disabled if the pin is configured as an output.



## REGISTER 11-22: ODCONC: PORTC OPEN-DRAIN CONTROL REGISTER

R/W-0/0	R/W-0/0	R/W-0/0	R/W-0/0	R/W-0/0	R/W-0/0	R/W-0/0	R/W-0/0
ODC7	ODC6	ODC5	ODC4	ODC3	ODC2	ODC1	ODC0
bit 7							bit 0

### Legend:

R = Readable bit                      W = Writable bit                      U = Unimplemented bit, read as '0'  
u = Bit is unchanged                      x = Bit is unknown                      -n/n = Value at POR and BOR/Value at all other Resets  
'1' = Bit is set                              '0' = Bit is cleared

bit 7-0                      **ODC<7:0>**: PORTC Open-Drain Enable bits  
For RC<7:0> pins, respectively  
1 = Port pin operates as open-drain drive (sink current only)  
0 = Port pin operates as standard push-pull drive (source and sink current)

## REGISTER 11-23: SLRCONC: PORTC SLEW RATE CONTROL REGISTER

R/W-1/1	R/W-1/1	R/W-1/1	R/W-1/1	R/W-1/1	R/W-1/1	R/W-1/1	R/W-1/1
SLRC7	SLRC6	SLRC5	SLRC4	SLRC3	SLRC2	SLRC1	SLRC0
bit 7							bit 0

### Legend:

R = Readable bit                      W = Writable bit                      U = Unimplemented bit, read as '0'  
u = Bit is unchanged                      x = Bit is unknown                      -n/n = Value at POR and BOR/Value at all other Resets  
'1' = Bit is set                              '0' = Bit is cleared

bit 7-0                      **SLRC<7:0>**: PORTC Slew Rate Enable bits  
For RC<7:0> pins, respectively  
1 = Port pin slew rate is limited  
0 = Port pin slews at maximum rate

## REGISTER 11-24: INLVLC: PORTC INPUT LEVEL CONTROL REGISTER

R/W-1/1	R/W-1/1	R/W-1/1	R/W-1/1	R/W-1/1	R/W-1/1	R/W-1/1	R/W-1/1
INLVLC7	INLVLC6	INLVLC5	INLVLC4	INLVLC3	INLVLC2	INLVLC1	INLVLC0
bit 7							bit 0

### Legend:

R = Readable bit                      W = Writable bit                      U = Unimplemented bit, read as '0'  
u = Bit is unchanged                      x = Bit is unknown                      -n/n = Value at POR and BOR/Value at all other Resets  
'1' = Bit is set                              '0' = Bit is cleared

bit 7-0                      **INLVLC<7:0>**: PORTC Input Level Select bits  
For RC<7:0> pins, respectively  
1 = Port pin digital input operates with ST thresholds  
0 = Port pin digital input operates with TTL thresholds

# PIC16(L)F1717/8/9

**TABLE 11-5: SUMMARY OF REGISTERS ASSOCIATED WITH PORTC**

Name	Bit 7	Bit 6	Bit 5	Bit 4	Bit 3	Bit 2	Bit 1	Bit 0	Register on Page
ANSEL	ANSC7	ANSC6	ANSC5	ANSC4	ANSC3	ANSC2	—	—	136
INLVLC	INLVLC7	INLVLC6	INLVLC5	INLVLC4	INLVLC3	INLVLC2	INLVLC1	INLVLC0	137
LATC	LATC7	LATC6	LATC5	LATC4	LATC3	LATC2	LATC1	LATC0	135
ODCONC	ODC7	ODC6	ODC5	ODC4	ODC3	ODC2	ODC1	ODC0	137
PORTC	RC7	RC6	RC5	RC4	RC3	RC2	RC1	RC0	135
SLRCONC	SLRC7	SLRC6	SLRC5	SLRC4	SLRC3	SLRC2	SLRC1	SLRC0	137
TRISC	TRISC7	TRISC6	TRISC5	TRISC4	TRISC3	TRISC2	TRISC1	TRISC0	135
WPUC	WPUC7	WPUC6	WPUC5	WPUC4	WPUC3	WPUC2	WPUC1	WPUC0	136

**Legend:** x = unknown, u = unchanged, - = unimplemented locations read as '0'. Shaded cells are not used by PORTC.

## 11.7 PORTD Registers (PIC16(L)F1717/9 only)

### 11.7.1 DATA REGISTER

PORTD is an 8-bit wide bidirectional port. The corresponding data direction register is TRISD (Register 11-26). Setting a TRISD bit (= 1) will make the corresponding PORTD pin an input (i.e., put the corresponding output driver in a High-Impedance mode). Clearing a TRISD bit (= 0) will make the corresponding PORTD pin an output (i.e., enable the output driver and put the contents of the output latch on the selected pin). Example 11-1 shows how to initialize an I/O port.

Reading the PORTD register (Register 11-25) reads the status of the pins, whereas writing to it will write to the PORT latch. All write operations are read-modify-write operations. Therefore, a write to a port implies that the port pins are read, this value is modified and then written to the PORT data latch (LATD).

### 11.7.2 DIRECTION CONTROL

The TRISD register (Register 11-26) controls the PORTD pin output drivers, even when they are being used as analog inputs. The user should ensure the bits in the TRISD register are maintained set when using them as analog inputs. I/O pins configured as analog inputs always read '0'.

### 11.7.3 INPUT THRESHOLD CONTROL

The INLVLD register (Register 11-32) controls the input voltage threshold for each of the available PORTD input pins. A selection between the Schmitt Trigger CMOS or the TTL compatible thresholds is available. The input threshold is important in determining the value of a read of the PORTD register and also the level at which an interrupt-on-change occurs, if that feature is enabled. See Table 34-4: I/O Ports for more information on threshold levels.

**Note:** Changing the input threshold selection should be performed while all peripheral modules are disabled. Changing the threshold level during the time a module is active may inadvertently generate a transition associated with an input pin, regardless of the actual voltage level on that pin.

### 11.7.4 OPEN-DRAIN CONTROL

The ODCOND register (Register 11-30) controls the open-drain feature of the port. Open-drain operation is independently selected for each pin. When an ODCOND bit is set, the corresponding port output becomes an open-drain driver capable of sinking current only. When an ODCOND bit is cleared, the corresponding port output pin is the standard push-pull drive capable of sourcing and sinking current.

### 11.7.5 SLEW RATE CONTROL

The SLRCOND register (Register 11-31) controls the slew rate option for each port pin. Slew rate control is independently selectable for each port pin. When an SLRCOND bit is set, the corresponding port pin drive is slew rate limited. When an SLRCOND bit is cleared, the corresponding port pin drive slews at the maximum rate possible.

### 11.7.6 ANALOG CONTROL

The ANSEL register (Register 11-28) is used to configure the Input mode of an I/O pin to analog. Setting the appropriate ANSEL bit high will cause all digital reads on the pin to be read as '0' and allow analog functions on the pin to operate correctly.

The state of the ANSEL bits has no effect on digital output functions. A pin with TRIS clear and ANSEL set will still operate as a digital output, but the Input mode will be analog. This can cause unexpected behavior when executing read-modify-write instructions on the affected port.

**Note:** The ANSEL bits default to the Analog mode after Reset. To use any pins as digital general purpose or peripheral inputs, the corresponding ANSEL bits must be initialized to '0' by user software.

### 11.7.7 PORTD FUNCTIONS AND OUTPUT PRIORITIES

Each pin defaults to the PORT latch data after Reset. Other functions are selected with the peripheral pin select logic. See Section 12.0 "Peripheral Pin Select (PPS) Module" for more information.

Analog input functions, such as ADC and comparator inputs, are not shown in the peripheral pin select lists. These inputs are active when the I/O pin is set for Analog mode using the ANSEL register. Digital output functions may continue to control the pin when it is in Analog mode.

# PIC16(L)F1717/8/9

## 11.8 Register Definitions: PORTD

### REGISTER 11-25: PORTD: PORTD REGISTER

R/W-x/u	R/W-x/u	R/W-x/u	R/W-x/u	R/W-x/u	R/W-x/u	R/W-x/u	R/W-x/u
RD7	RD6	RD5	RD4	RD3	RD2	RD1	RD0
bit 7							bit 0

**Legend:**

R = Readable bit                      W = Writable bit                      U = Unimplemented bit, read as '0'  
u = Bit is unchanged                  x = Bit is unknown                    -n/n = Value at POR and BOR/Value at all other Resets  
'1' = Bit is set                          '0' = Bit is cleared

bit 7-0            **RD<7:0>**: PORTD General Purpose I/O Pin bits<sup>(1)</sup>  
1 = Port pin is  $\geq V_{IH}$   
0 = Port pin is  $\leq V_{IL}$

**Note 1:** Writes to PORTD are actually written to corresponding LATD register. Reads from PORTD register is return of actual I/O pin values.

### REGISTER 11-26: TRISD: PORTD TRI-STATE REGISTER

R/W-1/1	R/W-1/1	R/W-1/1	R/W-1/1	R/W-1/1	R/W-1/1	R/W-1/1	R/W-1/1
TRISD7	TRISD6	TRISD5	TRISD4	TRISD3	TRISD2	TRISD1	TRISD0
bit 7							bit 0

**Legend:**

R = Readable bit                      W = Writable bit                      U = Unimplemented bit, read as '0'  
u = Bit is unchanged                  x = Bit is unknown                    -n/n = Value at POR and BOR/Value at all other Resets  
'1' = Bit is set                          '0' = Bit is cleared

bit 7-0            **TRISD<7:0>**: PORTD Tri-State Control bits  
1 = PORTD pin configured as an input (tri-stated)  
0 = PORTD pin configured as an output

### REGISTER 11-27: LATD: PORTD DATA LATCH REGISTER

R/W-x/u	R/W-x/u	R/W-x/u	R/W-x/u	R/W-x/u	R/W-x/u	R/W-x/u	R/W-x/u
LATD7	LATD6	LATD5	LATD4	LATD3	LATD2	LATD1	LATD0
bit 7							bit 0

**Legend:**

R = Readable bit                      W = Writable bit                      U = Unimplemented bit, read as '0'  
u = Bit is unchanged                  x = Bit is unknown                    -n/n = Value at POR and BOR/Value at all other Resets  
'1' = Bit is set                          '0' = Bit is cleared

bit 7-0            **LATD<7:0>**: PORTD Output Latch Value bits

## REGISTER 11-28: ANSEL: PORTD ANALOG SELECT REGISTER

R/W-1/1	R/W-1/1	R/W-1/1	R/W-1/1	R/W-1/1	R/W-1/1	R/W-1/1	R/W-1/1
ANSD7	ANSD6	ANSD5	ANSD4	ANSD3	ANSD2	ANSD1	ANSD0
bit 7							bit 0

### Legend:

R = Readable bit	W = Writable bit	U = Unimplemented bit, read as '0'
u = Bit is unchanged	x = Bit is unknown	-n/n = Value at POR and BOR/Value at all other Resets
'1' = Bit is set	'0' = Bit is cleared	

bit 7-0      **ANSD<7:0>**: Analog Select between Analog or Digital Function on Pins RD<7:0>, respectively<sup>(1)</sup>  
 0 = Digital I/O. Pin is assigned to port or digital special function.  
 1 = Analog input. Pin is assigned as analog input<sup>(1)</sup>. Digital input buffer disabled.

**Note 1:** When setting a pin to an analog input, the corresponding TRIS bit must be set to Input mode in order to allow external control of the voltage on the pin.

## REGISTER 11-29: WPUD: WEAK PULL-UP PORTD REGISTER<sup>(1,2)</sup>

R/W-1/1	R/W-1/1	R/W-1/1	R/W-1/1	R/W-1/1	R/W-1/1	R/W-1/1	R/W-1/1
WPUD7	WPUD6	WPUD5	WPUD4	WPUD3	WPUD2	WPUD1	WPUD0
bit 7							bit 0

### Legend:

R = Readable bit	W = Writable bit	U = Unimplemented bit, read as '0'
u = Bit is unchanged	x = Bit is unknown	-n/n = Value at POR and BOR/Value at all other Resets
'1' = Bit is set	'0' = Bit is cleared	

bit 7-0      **WPUD<7:0>**: Weak Pull-up Register bits  
 1 = Pull-up enabled  
 0 = Pull-up disabled

**Note 1:** Global  $\overline{\text{WPUEN}}$  bit of the OPTION\_REG register must be cleared for individual pull-ups to be enabled.  
**Note 2:** The weak pull-up device is automatically disabled if the pin is configured as an output.

# PIC16(L)F1717/8/9

## REGISTER 11-30: ODCOND: PORTD OPEN-DRAIN CONTROL REGISTER

R/W-0/0	R/W-0/0	R/W-0/0	R/W-0/0	R/W-0/0	R/W-0/0	R/W-0/0	R/W-0/0
ODD7	ODD6	ODD5	ODD4	ODD3	ODD2	ODD1	ODD0
bit 7							bit 0

### Legend:

R = Readable bit                      W = Writable bit                      U = Unimplemented bit, read as '0'  
u = Bit is unchanged                  x = Bit is unknown                  -n/n = Value at POR and BOR/Value at all other Resets  
'1' = Bit is set                          '0' = Bit is cleared

bit 7-0                      **ODD<7:0>**: PORTD Open-Drain Enable bits  
For RD<7:0> pins, respectively  
1 = Port pin operates as open-drain drive (sink current only)  
0 = Port pin operates as standard push-pull drive (source and sink current)

## REGISTER 11-31: SLRCOND: PORTD SLEW RATE CONTROL REGISTER

R/W-1/1	R/W-1/1	R/W-1/1	R/W-1/1	R/W-1/1	R/W-1/1	R/W-1/1	R/W-1/1
SLRD7	SLRD6	SLRD5	SLRD4	SLRD3	SLRD2	SLRD1	SLRD0
bit 7							bit 0

### Legend:

R = Readable bit                      W = Writable bit                      U = Unimplemented bit, read as '0'  
u = Bit is unchanged                  x = Bit is unknown                  -n/n = Value at POR and BOR/Value at all other Resets  
'1' = Bit is set                          '0' = Bit is cleared

bit 7-0                      **SLRD<7:0>**: PORTD Slew Rate Enable bits  
For RD<7:0> pins, respectively  
1 = Port pin slew rate is limited  
0 = Port pin slews at maximum rate

## REGISTER 11-32: INLVLD: PORTD INPUT LEVEL CONTROL REGISTER

R/W-1/1	R/W-1/1	R/W-1/1	R/W-1/1	R/W-1/1	R/W-1/1	R/W-1/1	R/W-1/1
INLVLD7	INLVLD6	INLVLD5	INLVLD4	INLVLD3	INLVLD2	INLVLD1	INLVLD0
bit 7							bit 0

### Legend:

R = Readable bit                      W = Writable bit                      U = Unimplemented bit, read as '0'  
u = Bit is unchanged                  x = Bit is unknown                  -n/n = Value at POR and BOR/Value at all other Resets  
'1' = Bit is set                          '0' = Bit is cleared

bit 7-0                      **INLVLD<7:0>**: PORTD Input Level Select bits  
For RD<7:0> pins, respectively  
1 = Port pin digital input operates with ST thresholds  
0 = Port pin digital input operates with TTL thresholds

**TABLE 11-6: SUMMARY OF REGISTERS ASSOCIATED WITH PORTD**

Name	Bit 7	Bit 6	Bit 5	Bit 4	Bit 3	Bit 2	Bit 1	Bit 0	Register on Page
ANSELD	ANSD7	ANSD6	ANSD5	ANSD4	ANSD3	ANSD2	ANSD1	ANSD0	<a href="#">141</a>
INLVLD	INLVLD7	INLVLD6	INLVLD5	INLVLD4	INLVLD3	INLVLD2	INLVLD1	INLVLD0	<a href="#">142</a>
LATD	LATD7	LATD6	LATD5	LATD4	LATD3	LATD2	LATD1	LATD0	<a href="#">140</a>
ODCOND	ODD7	ODD6	ODD5	ODD4	ODD3	ODD2	ODD1	ODD0	<a href="#">142</a>
PORTD	RD7	RD6	RD5	RD4	RD3	RD2	RD1	RD0	<a href="#">140</a>
SLRCOND	SLRD7	SLRD6	SLRD5	SLRD4	SLRD3	SLRD2	SLRD1	SLRD0	<a href="#">142</a>
TRISD	TRISD7	TRISD6	TRISD5	TRISD4	TRISD3	TRISD2	TRISD1	TRISD0	<a href="#">140</a>
WPUD	WPUD7	WPUD6	WPUD5	WPUD4	WPUD3	WPUD2	WPUD1	WPUD0	<a href="#">141</a>

**Legend:** x = unknown, u = unchanged, - = unimplemented locations read as '0'. Shaded cells are not used by PORTD.

# PIC16(L)F1717/8/9

## 11.9 PORTE Registers

### 11.9.1 DATA REGISTER (RE<2:0> PIC16(L)F1717/9 ONLY)

PORTE is a 4-bit wide input port and 3-bit wide output port. The corresponding data direction register is TRISE (Register 11-34). Setting a TRISE bit (= 1) will make the corresponding PORTE pin an input (i.e., put the corresponding output driver in a High-Impedance mode). Clearing a TRISE bit (= 0) will make the corresponding PORTE pin an output (i.e., enable the output driver and put the contents of the output latch on the selected pin). Example 11-1 shows how to initialize an I/O port.

Reading the PORTE register (Register 11-33) reads the status of the pins, whereas writing to it will write to the PORT latch. All write operations are read-modify-write operations. Therefore, a write to a port implies that the port pins are read, this value is modified and then written to the PORT data latch (LATE).

### 11.9.2 DIRECTION CONTROL (TRISE<2:0> PIC16(L)F1717/9 ONLY)

The TRISE register (Register 11-34) controls the PORTE pin output drivers, even when they are being used as analog inputs. The user should ensure the bits in the TRISE register are maintained set when using them as analog inputs. I/O pins configured as analog inputs always read '0'.

### 11.9.3 INPUT THRESHOLD CONTROL (PIC16(L)F1717/9 ONLY)

The INLVLE register (Register 11-40) controls the input voltage threshold for each of the available PORTE input pins. A selection between the Schmitt Trigger CMOS or the TTL compatible thresholds is available. The input threshold is important in determining the value of a read of the PORTE register and also the level at which an interrupt-on-change occurs, if that feature is enabled. See Table 34-4: I/O Ports for more information on threshold levels.

**Note:** Changing the input threshold selection should be performed while all peripheral modules are disabled. Changing the threshold level during the time a module is active may inadvertently generate a transition associated with an input pin, regardless of the actual voltage level on that pin.

### 11.9.4 OPEN-DRAIN CONTROL (PIC16(L)F1717/9 ONLY)

The ODCONE register (Register 11-38) controls the open-drain feature of the port. Open-drain operation is independently selected for each pin. When an ODCONE bit is set, the corresponding port output becomes an open-drain driver capable of sinking current only. When an ODCONE bit is cleared, the corresponding port output pin is the standard push-pull drive capable of sourcing and sinking current.

### 11.9.5 SLEW RATE CONTROL (PIC16(L)F1717/9 ONLY)

The SLRCONE register (Register 11-39) controls the slew rate option for each port pin. Slew rate control is independently selectable for each port pin. When an SLRCONE bit is set, the corresponding port pin drive is slew rate limited. When an SLRCONE bit is cleared, the corresponding port pin drive slews at the maximum rate possible.

### 11.9.6 ANALOG CONTROL (PIC16(L)F1717/9 ONLY)

The ANSELE register (Register 11-36) is used to configure the Input mode of an I/O pin to analog. Setting the appropriate ANSELE bit high will cause all digital reads on the pin to be read as '0' and allow analog functions on the pin to operate correctly.

The state of the ANSELE bits has no effect on digital output functions. A pin with TRIS clear and ANSELE set will still operate as a digital output, but the Input mode will be analog. This can cause unexpected behavior when executing read-modify-write instructions on the affected port.

**Note:** The ANSELE bits default to the Analog mode after Reset. To use any pins as digital general purpose or peripheral inputs, the corresponding ANSEL bits must be initialized to '0' by user software.

### 11.9.7 PORTE FUNCTIONS AND OUTPUT PRIORITIES (PIC16(L)F1717/9 ONLY)

Each pin defaults to the PORT latch data after Reset. Other functions are selected with the peripheral pin select logic. See Section 12.0 "Peripheral Pin Select (PPS) Module" for more information.

Analog input functions, such as ADC and comparator inputs, are not shown in the peripheral pin select lists. These inputs are active when the I/O pin is set for Analog mode using the ANSELE register. Digital output functions may continue to control the pin when it is in Analog mode.



## 11.10 Register Definitions: PORTE

### REGISTER 11-33: PORTE: PORTE REGISTER

U-0	U-0	U-0	U-0	R/W-x/u	R/W-x/u	R/W-x/u	R/W-x/u
—	—	—	—	RE3	RE2 <sup>(2)</sup>	RE1 <sup>(2)</sup>	RE0 <sup>(2)</sup>
bit 7							bit 0

#### Legend:

R = Readable bit	W = Writable bit	U = Unimplemented bit, read as '0'
u = Bit is unchanged	x = Bit is unknown	-n/n = Value at POR and BOR/Value at all other Resets
'1' = Bit is set	'0' = Bit is cleared	

bit 7-4      **Unimplemented:** Read as '0'

bit 3-0      **RE<3:0>:** PORTE General Purpose I/O Pin bits<sup>(1)</sup>  
                  1 = Port pin is  $\geq V_{IH}$   
                  0 = Port pin is  $\leq V_{IL}$

**Note 1:** Writes to PORTE are actually written to corresponding LATE register. Reads from PORTE register is return of actual I/O pin values.

**2:** PIC16(L)F1717/9 only.

### REGISTER 11-34: TRISE: PORTE TRI-STATE REGISTER

U-0	U-0	U-0	U-0	R-1	R/W-1/1	R/W-1/1	R/W-1/1
—	—	—	—	TRISE3	TRISE2 <sup>(1)</sup>	TRISE1 <sup>(1)</sup>	TRISE0 <sup>(1)</sup>
bit 7							bit 0

#### Legend:

R = Readable bit	W = Writable bit	U = Unimplemented bit, read as '0'
u = Bit is unchanged	x = Bit is unknown	-n/n = Value at POR and BOR/Value at all other Resets
'1' = Bit is set	'0' = Bit is cleared	

bit 7-4      **Unimplemented:** Read as '0'

bit 3-0      **TRISE<3:0>:** PORTE Tri-State Control bits  
                  1 = PORTE pin configured as an input (tri-stated)  
                  0 = PORTE pin configured as an output

**Note 1:** PIC16(L)F1717/9 only.

# PIC16(L)F1717/8/9

## REGISTER 11-35: LATE: PORTE DATA LATCH REGISTER<sup>(1)</sup>

U-0	U-0	U-0	U-0	U-0	R/W-x/u	R/W-x/u	R/W-x/u
—	—	—	—	—	LATE2	LATE1	LATE0
bit 7					bit 0		

### Legend:

R = Readable bit                      W = Writable bit                      U = Unimplemented bit, read as '0'  
u = Bit is unchanged                      x = Bit is unknown                      -n/n = Value at POR and BOR/Value at all other Resets  
'1' = Bit is set                              '0' = Bit is cleared

bit 7-3                      **Unimplemented:** Read as '0'  
bit 2-0                      **LATE<2:0>:** PORTE Output Latch Value bits  
**Note 1:** PIC16(L)F1717/9 only.

## REGISTER 11-36: ANSELE: PORTE ANALOG SELECT REGISTER<sup>(2)</sup>

U-0	U-0	U-0	U-0	U-0	R/W-1/1	R/W-1/1	R/W-1/1
—	—	—	—	—	ANSE2	ANSE1	ANSE0
bit 7					bit 0		

### Legend:

R = Readable bit                      W = Writable bit                      U = Unimplemented bit, read as '0'  
u = Bit is unchanged                      x = Bit is unknown                      -n/n = Value at POR and BOR/Value at all other Resets  
'1' = Bit is set                              '0' = Bit is cleared

bit 7-3                      **Unimplemented:** Read as '0'  
bit 2-0                      **ANSE<2:0>:** Analog Select between Analog or Digital Function on Pins RE<2:0>, respectively<sup>(1)</sup>  
0 =Digital I/O. Pin is assigned to port or digital special function.  
1 =Analog input. Pin is assigned as analog input<sup>(1)</sup>. Digital input buffer disabled.

**Note 1:** When setting a pin to an analog input, the corresponding TRIS bit must be set to Input mode in order to allow external control of the voltage on the pin.  
**2:** PIC16(L)F1717/9 only.

## REGISTER 11-37: WPUE: WEAK PULL-UP PORTE REGISTER<sup>(1,2)</sup>

U-0	U-0	U-0	U-0	R/W-1/1	R/W-1/1	R/W-1/1	R/W-1/1
—	—	—	—	WPUE3	WPUE2 <sup>(3)</sup>	WPUE1 <sup>(3)</sup>	WPUE0 <sup>(3)</sup>
bit 7							bit 0

### Legend:

R = Readable bit                      W = Writable bit                      U = Unimplemented bit, read as '0'  
u = Bit is unchanged                      x = Bit is unknown                      -n/n = Value at POR and BOR/Value at all other Resets  
'1' = Bit is set                              '0' = Bit is cleared

bit 7-4                      **Unimplemented:** Read as '0'  
bit 3-0                      **WPUE<3:0>:** Weak Pull-up Register bits  
                                    1 = Pull-up enabled  
                                    0 = Pull-up disabled

- Note 1:** Global  $\overline{\text{WPUEN}}$  bit of the OPTION\_REG register must be cleared for individual pull-ups to be enabled.  
**Note 2:** The weak pull-up device is automatically disabled if the pin is configured as an output.  
**Note 3:** PIC16(L)F1717/9 only.

## REGISTER 11-38: ODCONE: PORTE OPEN-DRAIN CONTROL REGISTER<sup>(1)</sup>

U-0	U-0	U-0	U-0	U-0	R/W-0/0	R/W-0/0	R/W-0/0
—	—	—	—	—	ODE2	ODE1	ODE0
bit 7							bit 0

### Legend:

R = Readable bit                      W = Writable bit                      U = Unimplemented bit, read as '0'  
u = Bit is unchanged                      x = Bit is unknown                      -n/n = Value at POR and BOR/Value at all other Resets  
'1' = Bit is set                              '0' = Bit is cleared

bit 7-3                      **Unimplemented:** Read as '0'  
bit 2-0                      **ODE<2:0>:** PORTE Open-Drain Enable bits  
                                    For RE<2:0> pins, respectively  
                                    1 = Port pin operates as open-drain drive (sink current only)  
                                    0 = Port pin operates as standard push-pull drive (source and sink current)

- Note 1:** PIC16(L)F1717/9 only.

# PIC16(L)F1717/8/9

## REGISTER 11-39: SLRCONE: PORTE SLEW RATE CONTROL REGISTER<sup>(1)</sup>

U-0	U-0	U-0	U-0	U-0	R/W-1/1	R/W-1/1	R/W-1/1
—	—	—	—	—	SLRE2	SLRE1	SLRE0
bit 7					bit 0		

### Legend:

R = Readable bit                      W = Writable bit                      U = Unimplemented bit, read as '0'  
u = Bit is unchanged                      x = Bit is unknown                      -n/n = Value at POR and BOR/Value at all other Resets  
'1' = Bit is set                              '0' = Bit is cleared

bit 7-3                      **Unimplemented:** Read as '0'  
bit 2-0                      **SLRE<2:0>:** PORTE Slew Rate Enable bits  
For RE<2:0> pins, respectively  
1 = Port pin slew rate is limited  
0 = Port pin slews at maximum rate

**Note 1:** PIC16(L)F1717/9 only.

## REGISTER 11-40: INLVLE: PORTE INPUT LEVEL CONTROL REGISTER<sup>(1)</sup>

U-0	U-0	U-0	U-0	R/W-1/1	R/W-1/1	R/W-1/1	R/W-1/1
—	—	—	—	INLVLE3	INLVLE2	INLVLE1	INLVLE0
bit 7				bit 0			

### Legend:

R = Readable bit                      W = Writable bit                      U = Unimplemented bit, read as '0'  
u = Bit is unchanged                      x = Bit is unknown                      -n/n = Value at POR and BOR/Value at all other Resets  
'1' = Bit is set                              '0' = Bit is cleared

bit 7-4                      **Unimplemented:** Read as '0'  
bit 3-0                      **INLVLE<3:0>:** PORTE Input Level Select bits  
For RE<3:0> pins, respectively  
1 = Port pin digital input operates with ST thresholds  
0 = Port pin digital input operates with TTL thresholds

**Note 1:** PIC16(L)F1717/9 only.

**TABLE 11-7: SUMMARY OF REGISTERS ASSOCIATED WITH PORTE**

Name	Bit 7	Bit 6	Bit 5	Bit 4	Bit 3	Bit 2	Bit 1	Bit 0	Register on Page
ANSELE <sup>(1)</sup>	—	—	—	—	—	ANSE2	ANSE1	ANSE0	<a href="#">146</a>
INLVLE	—	—	—	—	INLVLE3	INLVLE2 <sup>(1)</sup>	INLVLE1 <sup>(1)</sup>	INLVLE0 <sup>(1)</sup>	<a href="#">148</a>
LATE <sup>(1)</sup>	—	—	—	—	—	LATE2	LATE1	LATE0	<a href="#">146</a>
ODCONE <sup>(1)</sup>	—	—	—	—	—	ODE2	ODE1	ODE0	<a href="#">147</a>
PORTE	—	—	—	—	RE3	RE2 <sup>(1)</sup>	RE1 <sup>(1)</sup>	RE0 <sup>(1)</sup>	<a href="#">145</a>
SLRCONE <sup>(1)</sup>	—	—	—	—	—	SLRE2	SLRE1	SLRE0	<a href="#">148</a>
TRISE	—	—	—	—	TRISE3	TRISE2 <sup>(1)</sup>	TRISE1 <sup>(1)</sup>	TRISE0 <sup>(1)</sup>	<a href="#">145</a>
WPUE	—	—	—	—	WPUE3	WPUE2 <sup>(1)</sup>	WPUE1 <sup>(1)</sup>	WPUE0 <sup>(1)</sup>	<a href="#">147</a>

**Legend:** x = unknown, u = unchanged, - = unimplemented locations read as '0'. Shaded cells are not used by PORTE.

**Note 1:** PIC16(L)F1717/9 only.

# PIC16(L)F1717/8/9

## 12.0 PERIPHERAL PIN SELECT (PPS) MODULE

The Peripheral Pin Select (PPS) module connects peripheral inputs and outputs to the device I/O pins. Only digital signals are included in the selections. All analog inputs and outputs remain fixed to their assigned pins. Input and output selections are independent as shown in the simplified block diagram [Figure 12-1](#).

### 12.1 PPS Inputs

Each peripheral has a PPS register with which the inputs to the peripheral are selected. Inputs include the device pins.

Multiple peripherals can operate from the same source simultaneously. Port reads always return the pin level regardless of peripheral PPS selection. If a pin also has associated analog functions, the ANSEL bit for that pin must be cleared to enable the digital input buffer.

Although every peripheral has its own PPS input selection register, the selections are identical for every peripheral as shown in [Register 12-1](#).

**Note:** The notation “xxx” in the register name is a place holder for the peripheral identifier. For example, CLC1PPS.

### 12.2 PPS Outputs

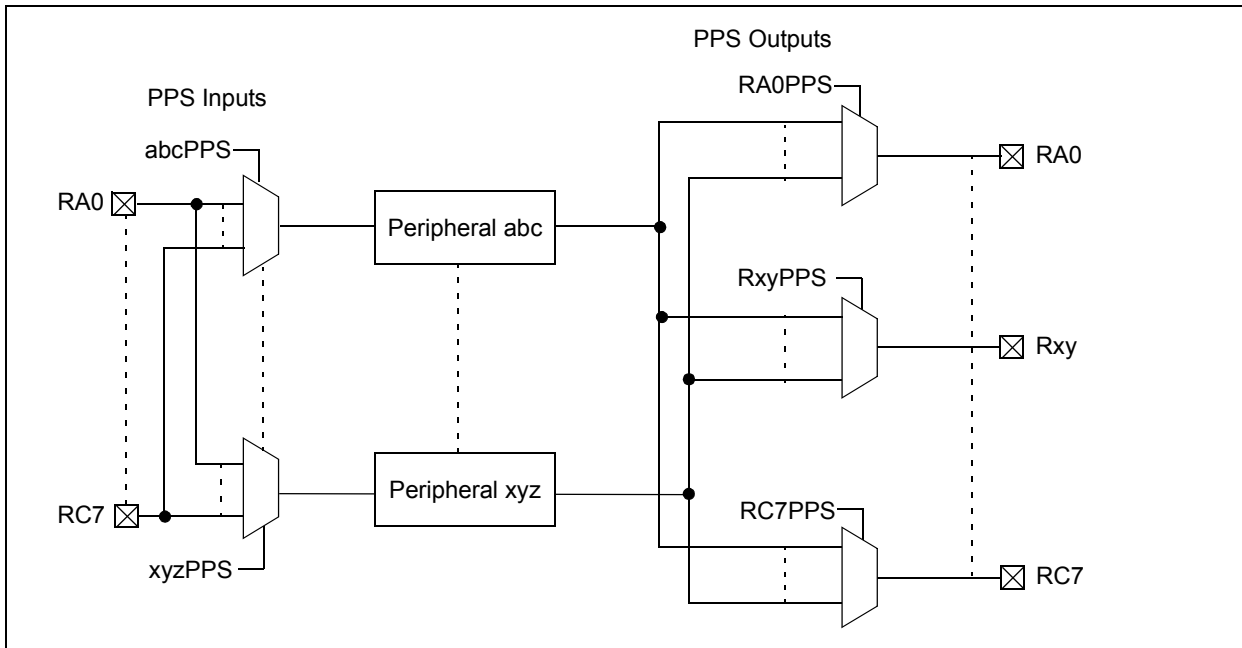
Each I/O pin has a PPS register with which the pin output source is selected. With few exceptions, the port TRIS control associated with that pin retains control over the pin output driver. Peripherals that control the pin output driver as part of the peripheral operation will override the TRIS control as needed. These peripherals include:

- EUSART (synchronous operation)
- MSSP (I<sup>2</sup>C)
- COG (auto-shutdown)

Although every pin has its own PPS peripheral selection register, the selections are identical for every pin as shown in [Register 12-2](#).

**Note:** The notation “Rxy” is a place holder for the pin identifier. For example, RA0PPS.

**FIGURE 12-1: SIMPLIFIED PPS BLOCK DIAGRAM**



## 12.3 Bidirectional Pins

PPS selections for peripherals with bidirectional signals on a single pin must be made so that the PPS input and PPS output select the same pin. Peripherals that have bidirectional signals include:

- EUSART (synchronous operation)
- MSSP (I<sup>2</sup>C)

**Note:** The I<sup>2</sup>C default input pins are I<sup>2</sup>C and SMBus compatible and are the only pins on the device with this compatibility.

## 12.4 PPS Lock

The PPS includes a mode in which all input and output selections can be locked to prevent inadvertent changes. PPS selections are locked by setting the PPSLOCKED bit of the PPSLOCK register. Setting and clearing this bit requires a special sequence as an extra precaution against inadvertent changes. Examples of setting and clearing the PPSLOCKED bit are shown in [Example 12-1](#).

### EXAMPLE 12-1: PPS LOCK/UNLOCK SEQUENCE

```
; suspend interrupts
    bcf    INTCON,GIE
; BANKSEL PPSLOCK    ; set bank
; required sequence, next 5 instructions
    movlw 0x55
    movwf PPSLOCK
    movlw 0xAA
    movwf PPSLOCK
; Set PPSLOCKED bit to disable writes or
; Clear PPSLOCKED bit to enable writes
    bsf    PPSLOCK,PPSLOCKED
; restore interrupts
    bsf    INTCON,GIE
```

## 12.5 PPS Permanent Lock

The PPS can be permanently locked by setting the PPS1WAY Configuration bit. When this bit is set, the PPSLOCKED bit can only be cleared and set one time after a device Reset. This allows for clearing the PPSLOCKED bit so that the input and output selections can be made during initialization. When the PPSLOCKED bit is set after all selections have been made, it will remain set and cannot be cleared until after the next device Reset event.

## 12.6 Operation During Sleep

PPS input and output selections are unaffected by Sleep.

## 12.7 Effects of a Reset

A device Power-On-Reset (POR) clears all PPS input and output selections to their default values. All other Resets leave the selections unchanged. Default input selections are shown in pin allocation [Table 1](#).

# PIC16(L)F1717/8/9

## 12.8 Register Definitions: PPS Input Selection

### REGISTER 12-1: xxxPPS: PERIPHERAL xxx INPUT SELECTION

U-0	U-0	U-0	R/W-q/u	R/W-q/u	R/W-q/u	R/W-q/u	R/W-q/u	
—	—	—	xxxPPS<4:0>					
bit 7								bit 0

#### Legend:

R = Readable bit	W = Writable bit	U = Unimplemented bit, read as '0'
u = Bit is unchanged	x = Bit is unknown	-n/n = Value at POR and BOR/Value at all other Resets
'1' = Bit is set	'0' = Bit is cleared	q = value depends on peripheral

bit 7-5 **Unimplemented:** Read as '0'

bit 4-3 **xxxPPS<4:3>:** Peripheral xxx Input PORTx Selection bits  
 See [Table 12-1](#) for the list of available ports for each peripheral.  
 11 = Peripheral input is from PORTD (PIC16(L)F1717/9 only)  
 10 = Peripheral input is from PORTC  
 01 = Peripheral input is from PORTB  
 00 = Peripheral input is from PORTA

bit 2-0 **xxxPPS<2:0>:** Peripheral xxx Input PORTx Bit Selection bits  
 111 = Peripheral input is from PORTx Bit 7 (Rx7)  
 110 = Peripheral input is from PORTx Bit 6 (Rx6)  
 101 = Peripheral input is from PORTx Bit 5 (Rx5)  
 100 = Peripheral input is from PORTx Bit 4 (Rx4)  
 011 = Peripheral input is from PORTx Bit 3 (Rx3)  
 010 = Peripheral input is from PORTx Bit 2 (Rx2)  
 001 = Peripheral input is from PORTx Bit 1 (Rx1)  
 000 = Peripheral input is from PORTx Bit 0 (Rx0)

**TABLE 12-1: AVAILABLE PORTS FOR INPUT BY PERIPHERAL**

Peripheral	Register	PIC16(L)F1717/8/9		PIC16(L)F1718	PIC16(L)F1717/9	
		PORTA	PORTB	PORTC	PORTC	PORTD
PIN interrupt	INTPPS	•	•			
Timer0 clock	T0CKIPPS	•	•			
Timer1 clock	T1CKIPPS	•		•	•	
Timer1 gate	T1GPPS		•	•	•	
CCP1	CCP1PPS		•	•	•	
CCP2	CCP2PPS		•	•	•	
COG	COGINPPS		•	•		•
MSSP	SSPCLKPPS		•	•	•	
MSSP	SSPDATPPS		•	•	•	
MSSP	SSPSSPPS	•		•		•
EUSART	RXPPS		•	•	•	
EUSART	CKPPS		•	•	•	
All CLCs	CLCIN0PPS	•		•	•	
All CLCs	CLCIN1PPS	•		•	•	
All CLCs	CLCIN2PPS		•	•		•
All CLCs	CLCIN3PPS		•	•		•

Example: CCP1PPS = 0x0B selects RB3 as the input to CCP1.

**Note:** Inputs are not available on all ports. A check in a port column of a peripheral row indicates that the port selection is valid for that peripheral. Unsupported ports will input a '0'.



# PIC16(L)F1717/8/9

**REGISTER 12-2: RxyPPS: PIN Rxy OUTPUT SOURCE SELECTION REGISTER**

U-0	U-0	U-0	R/W-0/u	R/W-0/u	R/W-0/u	R/W-0/u	R/W-0/u
—	—	—	RxyPPS<4:0>				
bit 7							bit 0

**Legend:**

R = Readable bit                      W = Writable bit                      U = Unimplemented bit, read as '0'  
u = Bit is unchanged                  x = Bit is unknown                  -n/n = Value at POR and BOR/Value at all other Resets  
'1' = Bit is set                            '0' = Bit is cleared

bit 7-5            **Unimplemented:** Read as '0'  
bit 4-0            **RxyPPS<4:0>:** Pin Rxy Output Source Selection bits.  
Selection code determines the output signal on the port pin.  
See [Table 12-2](#) for supported ports and selection codes.

**TABLE 12-2: AVAILABLE PORTS FOR OUTPUT BY PERIPHERAL <sup>(1)</sup>**

RxyPPS<4:0>	Output Signal	PIC16(L)F1717/8/9		PIC16(L)F1718	PIC16(L)F1717/9		
		PORTA	PORTB	PORTC	PORTC	PORTD	PORTE
11xxx	Reserved						
10111	C2OUT	•		•			•
10110	C1OUT	•		•		•	
10101	DT <sup>(2)</sup>		•	•	•		
10100	TX/CK <sup>(2)</sup>		•	•	•		
10011	Reserved						
10010	Reserved						
10001	SDO/SDA <sup>(2)</sup>		•	•	•		
10000	SCK/SCL <sup>(2)</sup>		•	•	•		
01111	PWM4OUT		•	•		•	
01110	PWM3OUT		•	•			•
01101	CCP2		•	•	•		
01100	CCP1		•	•	•		
01011	COG1D <sup>(2)</sup>		•	•		•	
01010	COG1C <sup>(2)</sup>		•	•		•	
01001	COG1B <sup>(2)</sup>		•	•		•	
01000	COG1A <sup>(2)</sup>		•	•	•		
00111	CLC4OUT		•	•		•	
00110	CLC3OUT		•	•		•	
00101	CLC2OUT	•		•	•		
00100	CLC1OUT	•		•	•		
00011	NCO1OUT	•		•		•	
00010	Reserved						
00001	Reserved						
00000	LATxy	•	•	•	•	•	•

Example: RB3PPS = 0x16 selects RB3 as the comparator 1 output.

**Note 1:** Outputs are not available on all ports. A check in a port column of a peripheral row indicates that the peripheral selection is valid for that port. Reserved output signals will output a '0'.

**2:** TRIS control is overridden by the peripheral as required.

# PIC16(L)F1717/8/9

**REGISTER 12-3: PPSLOCK: PPS LOCK REGISTER**

U-0	U-0	U-0	U-0	U-0	U-0	U-0	R/W-0/0
—	—	—	—	—	—	—	PPSLOCKED
bit 7							bit 0

**Legend:**

R = Readable bit                      W = Writable bit                      U = Unimplemented bit, read as '0'  
u = Bit is unchanged                  x = Bit is unknown                  -n/n = Value at POR and BOR/Value at all other Resets  
'1' = Bit is set                            '0' = Bit is cleared

bit 7-1            **Unimplemented:** Read as '0'  
bit 0                **PPSLOCKED:** PPS Locked bit  
                         1= PPS is locked. PPS selections can not be changed.  
                         0= PPS is not locked. PPS selections can be changed.

**TABLE 12-3: SUMMARY OF REGISTERS ASSOCIATED WITH THE PPS MODULE**

Name	Bit 7	Bit 6	Bit 5	Bit 4	Bit 3	Bit 2	Bit 1	Bit 0	Register on page
PPSLOCK	—	—	—	—	—	—	—	PPSLOCKED	154
INTPPS	—	—	—	INTPPS<4:0>					152
T0CKIPPS	—	—	—	T0CKIPPS<4:0>					152
T1CKIPPS	—	—	—	T1CKIPPS<4:0>					152
T1GPPS	—	—	—	T1GPPS<4:0>					152
CCP1PPS	—	—	—	CCP1PPS<4:0>					152
CCP2PPS	—	—	—	CCP2PPS<4:0>					152
COGINPPS	—	—	—	COGINPPS<4:0>					152
SSPCLKPPS	—	—	—	SSPCLKPPS<4:0>					152
SSPDATPPS	—	—	—	SSPDATPPS<4:0>					152
SSPSSPPS	—	—	—	SSPSSPPS<4:0>					152
RXPPS	—	—	—	RXPPS<4:0>					152
CKPPS	—	—	—	CKPPS<4:0>					152
CLCIN0PPS	—	—	—	CLCIN0PPS<4:0>					152
CLCIN1PPS	—	—	—	CLCIN1PPS<4:0>					152
CLCIN2PPS	—	—	—	CLCIN2PPS<4:0>					152
CLCIN3PPS	—	—	—	CLCIN3PPS<4:0>					152
RA0PPS	—	—	—	RA0PPS<4:0>					153
RA1PPS	—	—	—	RA1PPS<4:0>					153
RA2PPS	—	—	—	RA2PPS<4:0>					153
RA4PPS	—	—	—	RA4PPS<4:0>					153
RA5PPS	—	—	—	RA5PPS<4:0>					153
RA6PPS	—	—	—	RA6PPS<4:0>					153
RA7PPS	—	—	—	RA7PPS<4:0>					153

**Legend:** — = unimplemented, read as '0'. Shaded cells are unused by the PPS module.

**Note 1:** PIC16(L)F1717/9 only.

**TABLE 12-3: SUMMARY OF REGISTERS ASSOCIATED WITH THE PPS MODULE (CONTINUED)**

Name	Bit 7	Bit 6	Bit 5	Bit 4	Bit 3	Bit 2	Bit 1	Bit 0	Register on page
RB0PPS	—	—	—					RB0PPS<4:0>	153
RB1PPS	—	—	—					RB1PPS<4:0>	153
RB2PPS	—	—	—					RB2PPS<4:0>	153
RB3PPS	—	—	—					RB3PPS<4:0>	153
RB4PPS	—	—	—					RB4PPS<4:0>	153
RB5PPS	—	—	—					RB5PPS<4:0>	153
RB6PPS	—	—	—					RB6PPS<4:0>	153
RB7PPS	—	—	—					RB7PPS<4:0>	153
RC0PPS	—	—	—					RC0PPS<4:0>	153
RC1PPS	—	—	—					RC1PPS<4:0>	153
RC2PPS	—	—	—					RC2PPS<4:0>	153
RC3PPS	—	—	—					RC3PPS<4:0>	153
RC4PPS	—	—	—					RC4PPS<4:0>	153
RC5PPS	—	—	—					RC5PPS<4:0>	153
RC6PPS	—	—	—					RC6PPS<4:0>	153
RC7PPS	—	—	—					RC7PPS<4:0>	153
RD0PPS <sup>(1)</sup>	—	—	—					RD0PPS<4:0>	153
RD1PPS <sup>(1)</sup>	—	—	—					RD1PPS<4:0>	153
RD2PPS <sup>(1)</sup>	—	—	—					RD2PPS<4:0>	153
RD3PPS <sup>(1)</sup>	—	—	—					RD3PPS<4:0>	153
RD4PPS <sup>(1)</sup>	—	—	—					RD4PPS<4:0>	153
RD5PPS <sup>(1)</sup>	—	—	—					RD5PPS<4:0>	153
RD6PPS <sup>(1)</sup>	—	—	—					RD6PPS<4:0>	153
RD7PPS <sup>(1)</sup>	—	—	—					RD7PPS<4:0>	153
RE0PPS <sup>(1)</sup>	—	—	—					RE0PPS<4:0>	153
RE1PPS <sup>(1)</sup>	—	—	—					RE1PPS<4:0>	153
RE2PPS <sup>(1)</sup>	—	—	—					RE2PPS<4:0>	153

**Legend:** — = unimplemented, read as '0'. Shaded cells are unused by the PPS module.

**Note 1:** PIC16(L)F1717/9 only.

# PIC16(L)F1717/8/9

## 13.0 INTERRUPT-ON-CHANGE

All pins on all ports can be configured to operate as Interrupt-on-Change (IOC) pins. An interrupt can be generated by detecting a signal that has either a rising edge or a falling edge. Any individual pin, or combination of pins, can be configured to generate an interrupt. The interrupt-on-change module has the following features:

- Interrupt-on-Change enable (Master Switch)
- Individual pin configuration
- Rising and falling edge detection
- Individual pin interrupt flags

Figure 13-1 is a block diagram of the IOC module.

### 13.1 Enabling the Module

To allow individual pins to generate an interrupt, the IOCIE bit of the INTCON register must be set. If the IOCIE bit is disabled, the edge detection on the pin will still occur, but an interrupt will not be generated.

### 13.2 Individual Pin Configuration

For each pin, a rising edge detector and a falling edge detector are present. To enable a pin to detect a rising edge, the associated bit of the IOCxP register is set. To enable a pin to detect a falling edge, the associated bit of the IOCxN register is set.

A pin can be configured to detect rising and falling edges simultaneously by setting the associated bits in both of the IOCxP and IOCxN registers.

### 13.3 Interrupt Flags

The bits located in the IOCxF registers are status flags that correspond to the interrupt-on-change pins of each port. If an expected edge is detected on an appropriately enabled pin, then the status flag for that pin will be set, and an interrupt will be generated if the IOCIE bit is set. The IOCIF bit of the INTCON register reflects the status of all IOCxF bits.

## 13.4 Clearing Interrupt Flags

The individual status flags, (IOCxF register bits), can be cleared by resetting them to zero. If another edge is detected during this clearing operation, the associated status flag will be set at the end of the sequence, regardless of the value actually being written.

In order to ensure that no detected edge is lost while clearing flags, only AND operations masking out known changed bits should be performed. The following sequence is an example of what should be performed.

### EXAMPLE 13-1: CLEARING INTERRUPT FLAGS (PORTA EXAMPLE)

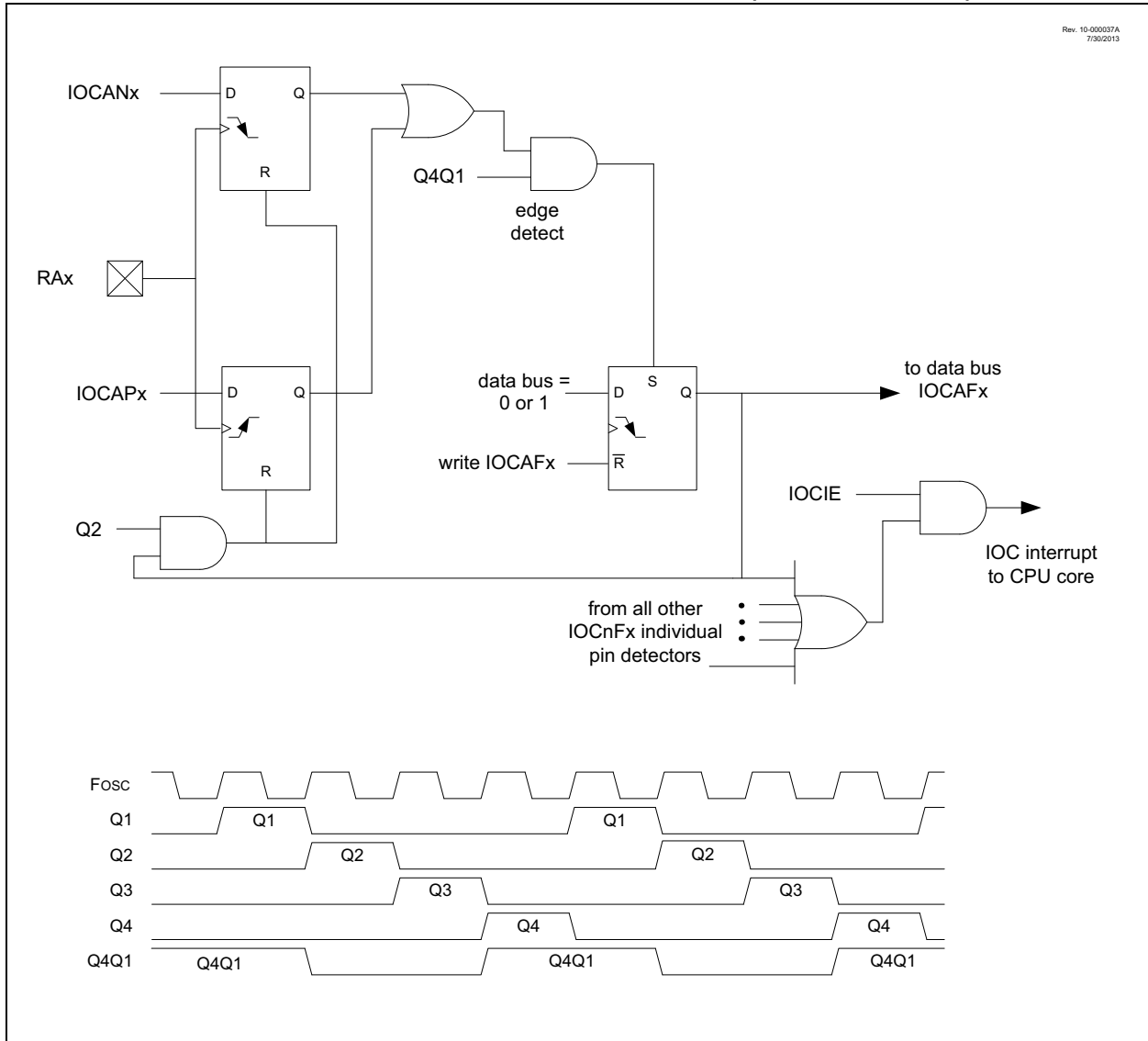
```
MOVLW 0xff
XORWF IOCAF, W
ANDWF IOCAF, F
```

### 13.5 Operation in Sleep

The interrupt-on-change interrupt sequence will wake the device from Sleep mode, if the IOCIE bit is set.

If an edge is detected while in Sleep mode, the affected IOCxF register will be updated prior to the first instruction executed out of Sleep.

**FIGURE 13-1: INTERRUPT-ON-CHANGE BLOCK DIAGRAM (PORTA EXAMPLE)**



# PIC16(L)F1717/8/9

## 13.6 Register Definitions: Interrupt-on-Change Control

### REGISTER 13-1: IOCAP: INTERRUPT-ON-CHANGE PORTA POSITIVE EDGE REGISTER

R/W-0/0	R/W-0/0	R/W-0/0	R/W-0/0	R/W-0/0	R/W-0/0	R/W-0/0	R/W-0/0
IOCAP7	IOCAP6	IOCAP5	IOCAP4	IOCAP3	IOCAP2	IOCAP1	IOCAP0
bit 7							bit 0

#### Legend:

R = Readable bit                      W = Writable bit                      U = Unimplemented bit, read as '0'  
u = Bit is unchanged                      x = Bit is unknown                      -n/n = Value at POR and BOR/Value at all other Resets  
'1' = Bit is set                              '0' = Bit is cleared

bit 7-0                      **IOCAP<7:0>**: Interrupt-on-Change PORTA Positive Edge Enable bits  
1 = Interrupt-on-Change enabled on the pin for a positive going edge. IOCAF<sub>x</sub> bit and IOCIF flag will be set upon detecting an edge.  
0 = Interrupt-on-Change disabled for the associated pin.

### REGISTER 13-2: IOCAN: INTERRUPT-ON-CHANGE PORTA NEGATIVE EDGE REGISTER

R/W-0/0	R/W-0/0	R/W-0/0	R/W-0/0	R/W-0/0	R/W-0/0	R/W-0/0	R/W-0/0
IOCAN7	IOCAN6	IOCAN5	IOCAN4	IOCAN3	IOCAN2	IOCAN1	IOCAN0
bit 7							bit 0

#### Legend:

R = Readable bit                      W = Writable bit                      U = Unimplemented bit, read as '0'  
u = Bit is unchanged                      x = Bit is unknown                      -n/n = Value at POR and BOR/Value at all other Resets  
'1' = Bit is set                              '0' = Bit is cleared

bit 7-0                      **IOCAN<7:0>**: Interrupt-on-Change PORTA Negative Edge Enable bits  
1 = Interrupt-on-Change enabled on the pin for a negative going edge. IOCAF<sub>x</sub> bit and IOCIF flag will be set upon detecting an edge.  
0 = Interrupt-on-Change disabled for the associated pin.

### REGISTER 13-3: IOCAF: INTERRUPT-ON-CHANGE PORTA FLAG REGISTER

R/W/HS-0/0	R/W/HS-0/0	R/W/HS-0/0	R/W/HS-0/0	R/W/HS-0/0	R/W/HS-0/0	R/W/HS-0/0	R/W/HS-0/0
IOCAF7	IOCAF6	IOCAF5	IOCAF4	IOCAF3	IOCAF2	IOCAF1	IOCAF0
bit 7							bit 0

#### Legend:

R = Readable bit                      W = Writable bit                      U = Unimplemented bit, read as '0'  
u = Bit is unchanged                      x = Bit is unknown                      -n/n = Value at POR and BOR/Value at all other Resets  
'1' = Bit is set                              '0' = Bit is cleared                      HS - Bit is set in hardware

bit 7-0                      **IOCAF<7:0>**: Interrupt-on-Change PORTA Flag bits  
1 = An enabled change was detected on the associated pin.  
Set when IOCAP<sub>x</sub> = 1 and a rising edge was detected on RAX, or when IOCAN<sub>x</sub> = 1 and a falling edge was detected on RAX.  
0 = No change was detected, or the user cleared the detected change.

## REGISTER 13-4: IOCBP: INTERRUPT-ON-CHANGE PORTB POSITIVE EDGE REGISTER

R/W-0/0	R/W-0/0	R/W-0/0	R/W-0/0	R/W-0/0	R/W-0/0	R/W-0/0	R/W-0/0
IOCBP7	IOCBP6	IOCBP5	IOCBP4	IOCBP3	IOCBP2	IOCBP1	IOCBP0
bit 7							bit 0

### Legend:

R = Readable bit	W = Writable bit	U = Unimplemented bit, read as '0'
u = Bit is unchanged	x = Bit is unknown	-n/n = Value at POR and BOR/Value at all other Resets
'1' = Bit is set	'0' = Bit is cleared	

- bit 7-0      **IOCBP<7:0>**: Interrupt-on-Change PORTB Positive Edge Enable bits  
 1 = Interrupt-on-Change enabled on the pin for a positive going edge. IOCBFx bit and IOCIF flag will be set upon detecting an edge.  
 0 = Interrupt-on-Change disabled for the associated pin

## REGISTER 13-5: IOCBN: INTERRUPT-ON-CHANGE PORTB NEGATIVE EDGE REGISTER

R/W-0/0	R/W-0/0	R/W-0/0	R/W-0/0	R/W-0/0	R/W-0/0	R/W-0/0	R/W-0/0
IOCBN7	IOCBN6	IOCBN5	IOCBN4	IOCBN3	IOCBN2	IOCBN1	IOCBN0
bit 7							bit 0

### Legend:

R = Readable bit	W = Writable bit	U = Unimplemented bit, read as '0'
u = Bit is unchanged	x = Bit is unknown	-n/n = Value at POR and BOR/Value at all other Resets
'1' = Bit is set	'0' = Bit is cleared	

- bit 7-0      **IOCBN<7:0>**: Interrupt-on-Change PORTB Negative Edge Enable bits  
 1 = Interrupt-on-Change enabled on the pin for a negative going edge. IOCBFx bit and IOCIF flag will be set upon detecting an edge.  
 0 = Interrupt-on-Change disabled for the associated pin.

## REGISTER 13-6: IOCBF: INTERRUPT-ON-CHANGE PORTB FLAG REGISTER

R/W/HS-0/0	R/W/HS-0/0	R/W/HS-0/0	R/W/HS-0/0	R/W/HS-0/0	R/W/HS-0/0	R/W/HS-0/0	R/W/HS-0/0
IOCBF7	IOCBF6	IOCBF5	IOCBF4	IOCBF3	IOCBF2	IOCBF1	IOCBF0
bit 7							bit 0

### Legend:

R = Readable bit	W = Writable bit	U = Unimplemented bit, read as '0'
u = Bit is unchanged	x = Bit is unknown	-n/n = Value at POR and BOR/Value at all other Resets
'1' = Bit is set	'0' = Bit is cleared	HS - Bit is set in hardware

- bit 7-0      **IOCBF<7:0>**: Interrupt-on-Change PORTB Flag bits  
 1 = An enabled change was detected on the associated pin.  
     Set when IOCBPx = 1 and a rising edge was detected on RBx, or when IOCBNx = 1 and a falling edge was detected on RBx.  
 0 = No change was detected, or the user cleared the detected change.

# PIC16(L)F1717/8/9

## REGISTER 13-7: IOCCP: INTERRUPT-ON-CHANGE PORTC POSITIVE EDGE REGISTER

R/W-0/0	R/W-0/0	R/W-0/0	R/W-0/0	R/W-0/0	R/W-0/0	R/W-0/0	R/W-0/0
IOCCP7	IOCCP6	IOCCP5	IOCCP4	IOCCP3	IOCCP2	IOCCP1	IOCCP0
bit 7							bit 0

### Legend:

R = Readable bit                      W = Writable bit                      U = Unimplemented bit, read as '0'  
u = Bit is unchanged                  x = Bit is unknown                  -n/n = Value at POR and BOR/Value at all other Resets  
'1' = Bit is set                          '0' = Bit is cleared

bit 7-0                      **IOCCP<7:0>**: Interrupt-on-Change PORTC Positive Edge Enable bits  
1 = Interrupt-on-Change enabled on the pin for a positive going edge. IOCCFx bit and IOCIF flag will be set upon detecting an edge.  
0 = Interrupt-on-Change disabled for the associated pin.

## REGISTER 13-8: IOCCN: INTERRUPT-ON-CHANGE PORTC NEGATIVE EDGE REGISTER

R/W-0/0	R/W-0/0	R/W-0/0	R/W-0/0	R/W-0/0	R/W-0/0	R/W-0/0	R/W-0/0
IOCCN7	IOCCN6	IOCCN5	IOCCN4	IOCCN3	IOCCN2	IOCCN1	IOCCN0
bit 7							bit 0

### Legend:

R = Readable bit                      W = Writable bit                      U = Unimplemented bit, read as '0'  
u = Bit is unchanged                  x = Bit is unknown                  -n/n = Value at POR and BOR/Value at all other Resets  
'1' = Bit is set                          '0' = Bit is cleared

bit 7-0                      **IOCCN<7:0>**: Interrupt-on-Change PORTC Negative Edge Enable bits  
1 = Interrupt-on-Change enabled on the pin for a negative going edge. IOCCFx bit and IOCIF flag will be set upon detecting an edge.  
0 = Interrupt-on-Change disabled for the associated pin.

## REGISTER 13-9: IOCCF: INTERRUPT-ON-CHANGE PORTC FLAG REGISTER

R/W/HS-0/0	R/W/HS-0/0	R/W/HS-0/0	R/W/HS-0/0	R/W/HS-0/0	R/W/HS-0/0	R/W/HS-0/0	R/W/HS-0/0
IOCCF7	IOCCF6	IOCCF5	IOCCF4	IOCCF3	IOCCF2	IOCCF1	IOCCF0
bit 7							bit 0

### Legend:

R = Readable bit                      W = Writable bit                      U = Unimplemented bit, read as '0'  
u = Bit is unchanged                  x = Bit is unknown                  -n/n = Value at POR and BOR/Value at all other Resets  
'1' = Bit is set                          '0' = Bit is cleared                  HS - Bit is set in hardware

bit 7-0                      **IOCCF<7:0>**: Interrupt-on-Change PORTC Flag bits  
1 = An enabled change was detected on the associated pin.  
Set when IOCCPx = 1 and a rising edge was detected on RCx, or when IOCCNx = 1 and a falling edge was detected on RCx.  
0 = No change was detected, or the user cleared the detected change.



## REGISTER 13-10: IOCEP: INTERRUPT-ON-CHANGE PORTE POSITIVE EDGE REGISTER

U-0	U-0	U-0	U-0	R/W-0/0	U-0	U-0	U-0
—	—	—	—	IOCEP3	—	—	—
bit 7				bit 0			

### Legend:

R = Readable bit	W = Writable bit	U = Unimplemented bit, read as '0'
u = Bit is unchanged	x = Bit is unknown	-n/n = Value at POR and BOR/Value at all other Resets
'1' = Bit is set	'0' = Bit is cleared	

bit 7-4      **Unimplemented:** Read as '0'

bit 3      **IOCEP3:** Interrupt-on-Change PORTE Positive Edge Enable bits

1 = Interrupt-on-Change enabled on the pin for a positive going edge. IOCEPx bit and IOCIF flag will be set upon detecting an edge.

0 = Interrupt-on-Change disabled for the associated pin.

bit 2-0      **Unimplemented:** Read as '0'

## REGISTER 13-11: IOCEN: INTERRUPT-ON-CHANGE PORTE NEGATIVE EDGE REGISTER

U-0	U-0	U-0	U-0	R/W-0/0	U-0	U-0	U-0
—	—	—	—	IOCEN3	—	—	—
bit 7				bit 0			

### Legend:

R = Readable bit	W = Writable bit	U = Unimplemented bit, read as '0'
u = Bit is unchanged	x = Bit is unknown	-n/n = Value at POR and BOR/Value at all other Resets
'1' = Bit is set	'0' = Bit is cleared	

bit 7-4      **Unimplemented:** Read as '0'

bit 3      **IOCEN3:** Interrupt-on-Change PORTE Negative Edge Enable bits

1 = Interrupt-on-Change enabled on the pin for a negative going edge. IOCEPx bit and IOCIF flag will be set upon detecting an edge.

0 = Interrupt-on-Change disabled for the associated pin.

bit 2-0      **Unimplemented:** Read as '0'

# PIC16(L)F1717/8/9

**REGISTER 13-12: IOCEF: INTERRUPT-ON-CHANGE PORTE FLAG REGISTER**

U-0	U-0	U-0	U-0	R/W/HS-0/0	U-0	U-0	U-0	
—	—	—	—	IOCEF3	—	—	—	
bit 7								bit 0

**Legend:**

R = Readable bit	W = Writable bit	U = Unimplemented bit, read as '0'
u = Bit is unchanged	x = Bit is unknown	-n/n = Value at POR and BOR/Value at all other Resets
'1' = Bit is set	'0' = Bit is cleared	HS - Bit is set in hardware

bit 7-4 **Unimplemented:** Read as '0'

bit 3 **IOCEF3:** Interrupt-on-Change PORTE Flag bits

1 = An enabled change was detected on the associated pin.

Set when IOCEPx = 1 and a rising edge was detected on REx, or when IOCENx = 1 and a falling edge was detected on REx.

0 = No change was detected, or the user cleared the detected change.

bit 2-0 **Unimplemented:** Read as '0'

**TABLE 13-1: SUMMARY OF REGISTERS ASSOCIATED WITH INTERRUPT-ON-CHANGE**

Name	Bit 7	Bit 6	Bit 5	Bit 4	Bit 3	Bit 2	Bit 1	Bit 0	Register on Page
ANSELA	—	—	ANSA5	ANSA4	ANSA3	ANSA2	ANSA1	ANSA0	125
ANSELB	—	—	ANSB5	ANSB4	ANSB3	ANSB2	ANSB1	ANSB0	131
ANSELC	ANSC7	ANSC6	ANSC5	ANSC4	ANSC3	ANSC2	—	—	136
INTCON	GIE	PEIE	TMR0IE	INTE	IOCFIE	TMR0IF	INTF	IOCFIF	90
IOCAF	IOCAF7	IOCAF6	IOCAF5	IOCAF4	IOCAF3	IOCAF2	IOCAF1	IOCAF0	158
IOCAN	IOCAN7	IOCAN6	IOCAN5	IOCAN4	IOCAN3	IOCAN2	IOCAN1	IOCAN0	158
IOCAP	IOCAP7	IOCAP6	IOCAP5	IOCAP4	IOCAP3	IOCAP2	IOCAP1	IOCAP0	158
IOCBF	IOCBF7	IOCBF6	IOCBF5	IOCBF4	IOCBF3	IOCBF2	IOCBF1	IOCBF0	159
IOCBN	IOCBN7	IOCBN6	IOCBN5	IOCBN4	IOCBN3	IOCBN2	IOCBN1	IOCBN0	159
IOCBP	IOCBP7	IOCBP6	IOCBP5	IOCBP4	IOCBP3	IOCBP2	IOCBP1	IOCBP0	159
IOCCF	IOCCF7	IOCCF6	IOCCF5	IOCCF4	IOCCF3	IOCCF2	IOCCF1	IOCCF0	160
IOCCN	IOCCN7	IOCCN6	IOCCN5	IOCCN4	IOCCN3	IOCCN2	IOCCN1	IOCCN0	160
IOCCP	IOCCP7	IOCCP6	IOCCP5	IOCCP4	IOCCP3	IOCCP2	IOCCP1	IOCCP0	160
IOCEF	—	—	—	—	IOCEF3	—	—	—	162
IOCEN	—	—	—	—	IOCEN3	—	—	—	161
IOCEP	—	—	—	—	IOCEP3	—	—	—	161
TRISA	TRISA7	TRISA6	TRISA5	TRISA4	TRISA3	TRISA2	TRISA1	TRISA0	124
TRISB	TRISB7	TRISB6	TRISB5	TRISB4	TRISB3	TRISB2	TRISB1	TRISB0	130
TRISC	TRISC7	TRISC6	TRISC5	TRISC4	TRISC3	TRISC2	TRISC1	TRISC0	135

**Legend:** — = unimplemented location, read as '0'. Shaded cells are not used by interrupt-on-change.

## 14.0 FIXED VOLTAGE REFERENCE (FVR)

The Fixed Voltage Reference, or FVR, is a stable voltage reference, independent of V<sub>DD</sub>, with 1.024V, 2.048V or 4.096V selectable output levels. The output of the FVR can be configured to supply a reference voltage to the following:

- ADC input channel
- ADC positive reference
- Comparator positive input
- Digital-to-Analog Converter (DAC)

The FVR can be enabled by setting the FVREN bit of the FVRCON register.

### 14.1 Independent Gain Amplifiers

The output of the FVR supplied to the ADC, comparators, and DAC is routed through two independent programmable gain amplifiers. Each amplifier can be programmed for a gain of 1x, 2x or 4x, to produce the three possible voltage levels.

The ADFVR<1:0> bits of the FVRCON register are used to enable and configure the gain amplifier settings for the reference supplied to the ADC module. Reference [Section 21.0 “Analog-to-Digital Converter \(ADC\) Module”](#) for additional information.

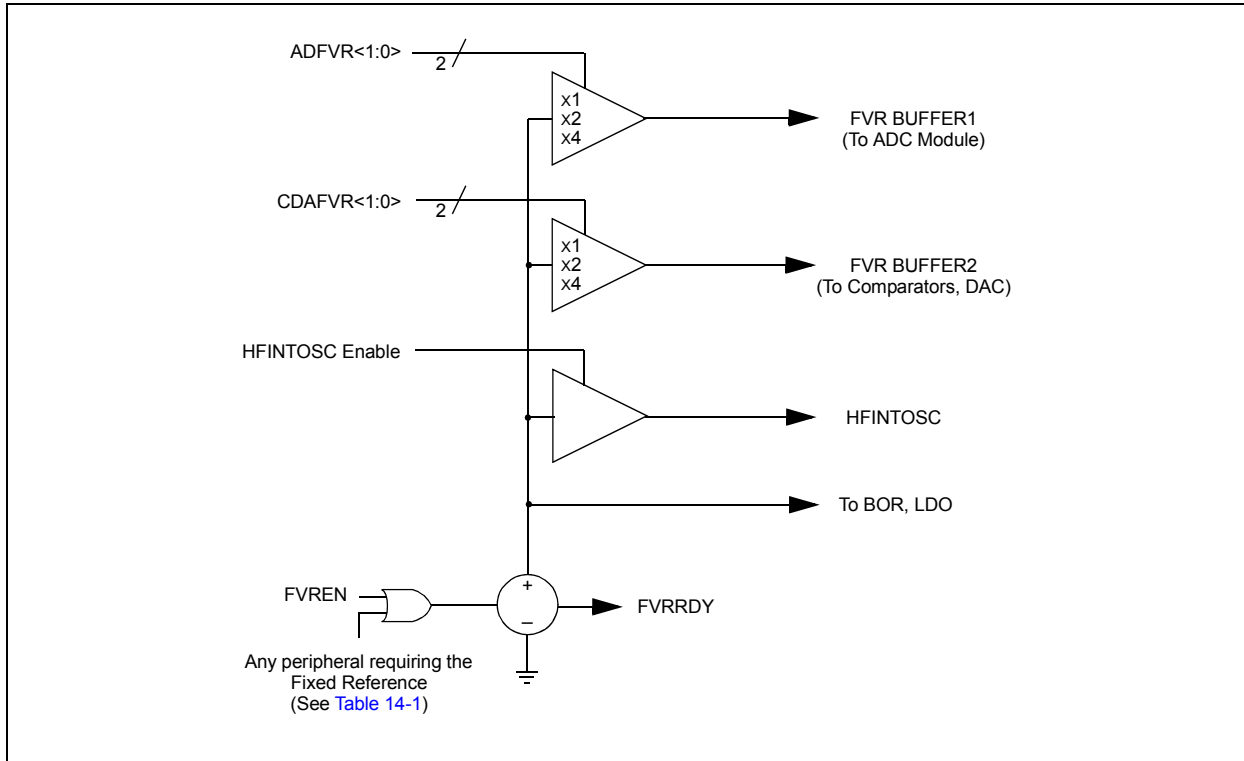
The CDAFVR<1:0> bits of the FVRCON register are used to enable and configure the gain amplifier settings for the reference supplied to the DAC and comparator module. Reference [Section 23.0 “8-Bit Digital-to-Analog Converter \(DAC1\) Module”](#) and [Section 16.0 “Comparator Module”](#) for additional information.

### 14.2 FVR Stabilization Period

When the Fixed Voltage Reference module is enabled, it requires time for the reference and amplifier circuits to stabilize. Once the circuits stabilize and are ready for use, the FVRRDY bit of the FVRCON register will be set. See [Figure 35-76: FVR Stabilization Period, PIC16LF1717/8/9 Only](#).

# PIC16(L)F1717/8/9

**FIGURE 14-1: VOLTAGE REFERENCE BLOCK DIAGRAM**



**TABLE 14-1: PERIPHERALS REQUIRING THE FIXED VOLTAGE REFERENCE (FVR)**

Peripheral	Conditions	Description
HFINTOSC	FOSC<2:0> = 100 and IRCF<3:0> ≠ 000x	INTOSC is active and device is not in Sleep
BOR	BOREN<1:0> = 11	BOR always enabled
	BOREN<1:0> = 10 and BORFS = 1	BOR disabled in Sleep mode, BOR Fast Start enabled
	BOREN<1:0> = 01 and BORFS = 1	BOR under software control, BOR Fast Start enabled
LDO	All PIC16F1717/8/9 devices, when VREGPM = 1 and not in Sleep	The device runs off of the ULP regulator when in Sleep mode

## 14.3 Register Definitions: FVR Control

**REGISTER 14-1: FVRCON: FIXED VOLTAGE REFERENCE CONTROL REGISTER**

R/W-0/0	R-q/q	R/W-0/0	R/W-0/0	R/W-0/0	R/W-0/0	R/W-0/0	R/W-0/0
FVREN	FVRRDY <sup>(1)</sup>	TSEN <sup>(3)</sup>	TSRNG <sup>(3)</sup>	CDAFVR<1:0>		ADFVR<1:0>	
bit 7							bit 0

**Legend:**

R = Readable bit	W = Writable bit	U = Unimplemented bit, read as '0'
u = Bit is unchanged	x = Bit is unknown	-n/n = Value at POR and BOR/Value at all other Resets
'1' = Bit is set	'0' = Bit is cleared	q = Value depends on condition

- bit 7      **FVREN:** Fixed Voltage Reference Enable bit  
 1 = Fixed Voltage Reference is enabled  
 0 = Fixed Voltage Reference is disabled
- bit 6      **FVRRDY:** Fixed Voltage Reference Ready Flag bit<sup>(1)</sup>  
 1 = Fixed Voltage Reference output is ready for use  
 0 = Fixed Voltage Reference output is not ready or not enabled
- bit 5      **TSEN:** Temperature Indicator Enable bit<sup>(3)</sup>  
 1 = Temperature Indicator is enabled  
 0 = Temperature Indicator is disabled
- bit 4      **TSRNG:** Temperature Indicator Range Selection bit<sup>(3)</sup>  
 1 = V<sub>OUT</sub> = V<sub>DD</sub> - 4V<sub>T</sub> (High Range)  
 0 = V<sub>OUT</sub> = V<sub>DD</sub> - 2V<sub>T</sub> (Low Range)
- bit 3-2    **CDAFVR<1:0>:** Comparator FVR Buffer Gain Selection bits  
 11 = Comparator FVR Buffer Gain is 4x, with output V<sub>CDAFVR</sub> = 4x V<sub>FVR</sub><sup>(2)</sup>  
 10 = Comparator FVR Buffer Gain is 2x, with output V<sub>CDAFVR</sub> = 2x V<sub>FVR</sub><sup>(2)</sup>  
 01 = Comparator FVR Buffer Gain is 1x, with output V<sub>CDAFVR</sub> = 1x V<sub>FVR</sub>  
 00 = Comparator FVR Buffer is off
- bit 1-0    **ADFVR<1:0>:** ADC FVR Buffer Gain Selection bit  
 11 = ADC FVR Buffer Gain is 4x, with output V<sub>ADFVR</sub> = 4x V<sub>FVR</sub><sup>(2)</sup>  
 10 = ADC FVR Buffer Gain is 2x, with output V<sub>ADFVR</sub> = 2x V<sub>FVR</sub><sup>(2)</sup>  
 01 = ADC FVR Buffer Gain is 1x, with output V<sub>ADFVR</sub> = 1x V<sub>FVR</sub>  
 00 = ADC FVR Buffer is off

- Note 1:** FVRRDY is always '1' on PIC16(L)F1717/8/9 only.  
**Note 2:** Fixed Voltage Reference output cannot exceed V<sub>DD</sub>.  
**Note 3:** See [Section 15.0 "Temperature Indicator Module"](#) for additional information.

**TABLE 14-2: SUMMARY OF REGISTERS ASSOCIATED WITH FIXED VOLTAGE REFERENCE**

Name	Bit 7	Bit 6	Bit 5	Bit 4	Bit 3	Bit 2	Bit 1	Bit 0	Register on page
FVRCON	FVREN	FVRRDY	TSEN	TSRNG	CDAFVR<1:0>		ADFVR<1:0>		165

**Legend:** Shaded cells are not used with the Fixed Voltage Reference.

# PIC16(L)F1717/8/9

## 15.0 TEMPERATURE INDICATOR MODULE

This family of devices is equipped with a temperature circuit designed to measure the operating temperature of the silicon die. The circuit's range of operating temperature falls between -40°C and +85°C. The output is a voltage that is proportional to the device temperature. The output of the temperature indicator is internally connected to the device ADC.

The circuit may be used as a temperature threshold detector or a more accurate temperature indicator, depending on the level of calibration performed. A one-point calibration allows the circuit to indicate a temperature closely surrounding that point. A two-point calibration allows the circuit to sense the entire range of temperature more accurately. Reference Application Note AN1333, "Use and Calibration of the Internal Temperature Indicator" (DS01333) for more details regarding the calibration process.

### 15.1 Circuit Operation

Figure 15-1 shows a simplified block diagram of the temperature circuit. The proportional voltage output is achieved by measuring the forward voltage drop across multiple silicon junctions.

Equation 15-1 describes the output characteristics of the temperature indicator.

#### EQUATION 15-1: $V_{OUT}$ RANGES

$$\text{High Range: } V_{OUT} = V_{DD} - 4V_T$$

$$\text{Low Range: } V_{OUT} = V_{DD} - 2V_T$$

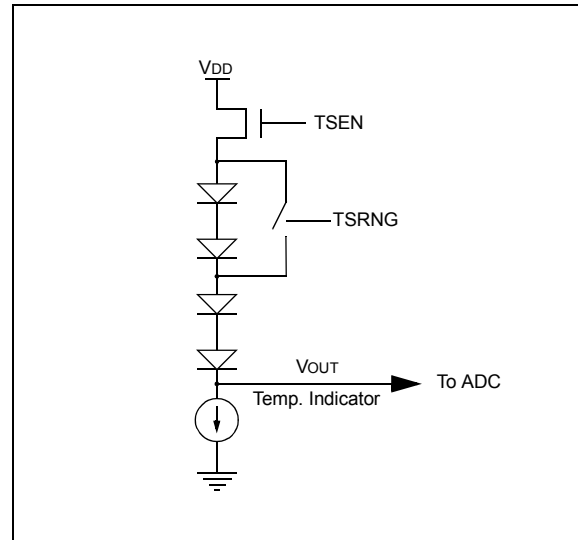
The temperature sense circuit is integrated with the Fixed Voltage Reference (FVR) module. See Section 14.0 "Fixed Voltage Reference (FVR)" for more information.

The circuit is enabled by setting the TSEN bit of the FVRCON register. When disabled, the circuit draws no current.

The circuit operates in either high or low range. The high range, selected by setting the TSRNG bit of the FVRCON register, provides a wider output voltage. This provides more resolution over the temperature range, but may be less consistent from part to part. This range requires a higher bias voltage to operate and thus, a higher VDD is needed.

The low range is selected by clearing the TSRNG bit of the FVRCON register. The low range generates a lower voltage drop and thus, a lower bias voltage is needed to operate the circuit. The low range is provided for low voltage operation.

FIGURE 15-1: TEMPERATURE CIRCUIT DIAGRAM



### 15.2 Minimum Operating VDD

When the temperature circuit is operated in low range, the device may be operated at any operating voltage that is within specifications.

When the temperature circuit is operated in high range, the device operating voltage, VDD, must be high enough to ensure that the temperature circuit is correctly biased.

Table 15-1 shows the recommended minimum VDD vs. range setting.

TABLE 15-1: RECOMMENDED VDD VS. RANGE

Min. VDD, TSRNG = 1	Min. VDD, TSRNG = 0
3.6V	1.8V

### 15.3 Temperature Output

The output of the circuit is measured using the internal Analog-to-Digital Converter. A channel is reserved for the temperature circuit output. Refer to Section 21.0 "Analog-to-Digital Converter (ADC) Module" for detailed information.

## 15.4 ADC Acquisition Time

To ensure accurate temperature measurements, the user must wait at least 200  $\mu\text{s}$  after the ADC input multiplexer is connected to the temperature indicator output before the conversion is performed. In addition, the user must wait 200  $\mu\text{s}$  between sequential conversions of the temperature indicator output.

**TABLE 15-2: SUMMARY OF REGISTERS ASSOCIATED WITH THE TEMPERATURE INDICATOR**

Name	Bit 7	Bit 6	Bit 5	Bit 4	Bit 3	Bit 2	Bit 1	Bit 0	Register on page
FVRCON	FVREN	FVRRDY	TSEN	TSRNG	CDFVR<1:0>	ADFVR<1:0>			165

**Legend:** Shaded cells are unused by the temperature indicator module.

# PIC16(L)F1717/8/9

## 16.0 COMPARATOR MODULE

Comparators are used to interface analog circuits to a digital circuit by comparing two analog voltages and providing a digital indication of their relative magnitudes. Comparators are very useful mixed signal building blocks because they provide analog functionality independent of program execution. The analog comparator module includes the following features:

- Independent comparator control
- Programmable input selection
- Comparator output is available internally/externally
- Programmable output polarity
- Interrupt-on-Change
- Wake-up from Sleep
- Programmable Speed/Power optimization
- PWM shutdown
- Programmable and Fixed Voltage Reference

### 16.1 Comparator Overview

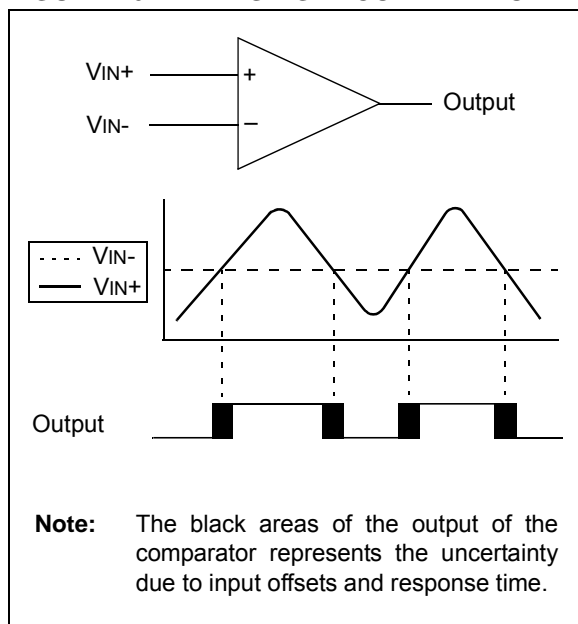
A single comparator is shown in [Figure 16-1](#) along with the relationship between the analog input levels and the digital output. When the analog voltage at  $V_{IN+}$  is less than the analog voltage at  $V_{IN-}$ , the output of the comparator is a digital low level. When the analog voltage at  $V_{IN+}$  is greater than the analog voltage at  $V_{IN-}$ , the output of the comparator is a digital high level.

The comparators available for this device are located in [Table 16-1](#).

**TABLE 16-1: AVAILABLE COMPARATORS**

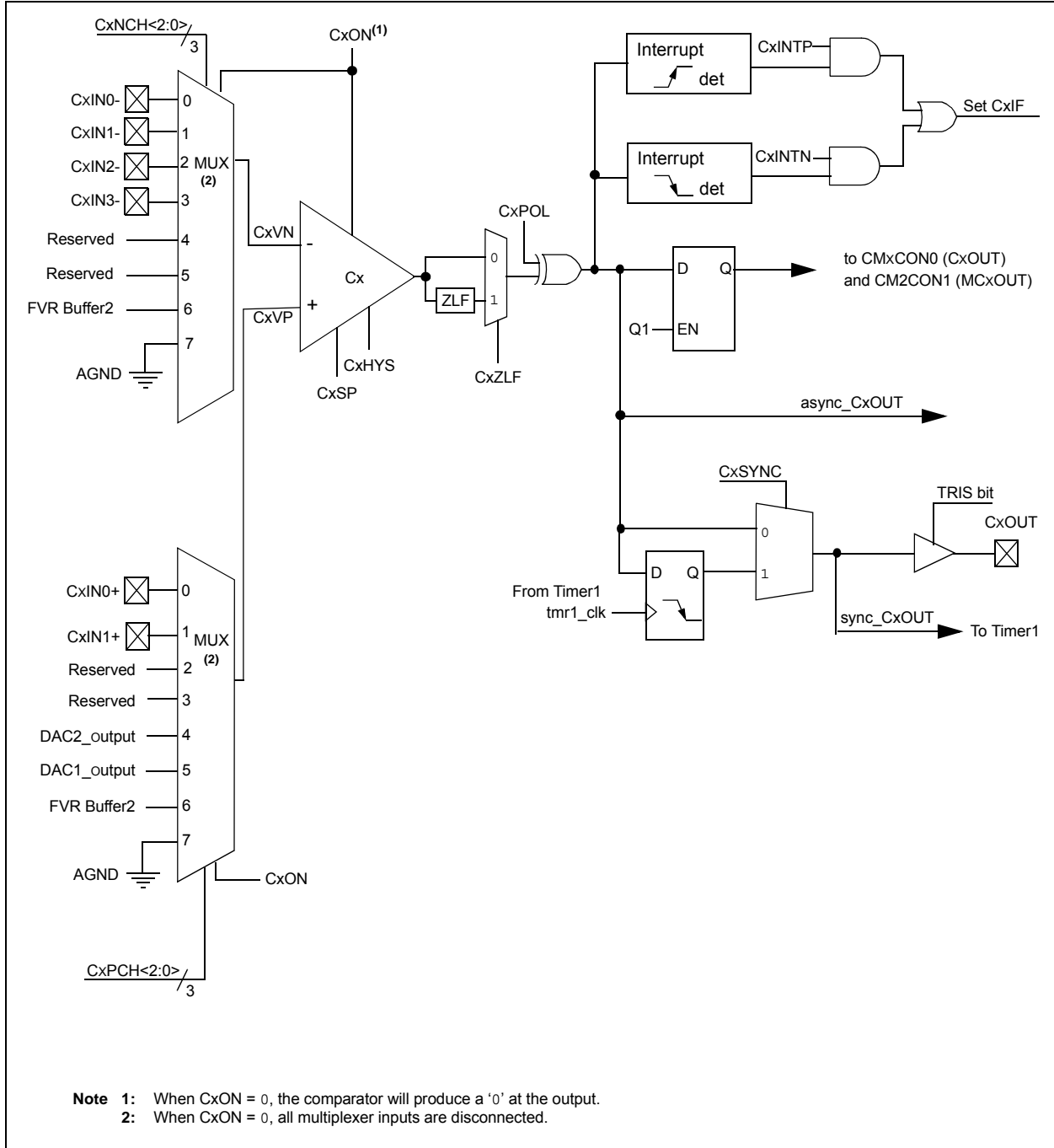
Device	C1	C2
PIC16(L)F1717/8/9	•	•

**FIGURE 16-1: SINGLE COMPARATOR**





**FIGURE 16-2: COMPARATOR MODULE SIMPLIFIED BLOCK DIAGRAM**



# PIC16(L)F1717/8/9

## 16.2 Comparator Control

Each comparator has two control registers: CMxCON0 and CMxCON1.

The CMxCON0 register (see [Register 16-1](#)) contains Control and Status bits for the following:

- Enable
- Output
- Output Polarity
- Zero Latency Filter
- Speed/Power Selection
- Hysteresis Enable
- Output Synchronization

The CMxCON1 register (see [Register 16-2](#)) contains Control bits for the following:

- Interrupt Enable
- Interrupt Edge Polarity
- Positive Input Channel Selection
- Negative Input Channel Selection

### 16.2.1 COMPARATOR ENABLE

Setting the CxON bit of the CMxCON0 register enables the comparator for operation. Clearing the CxON bit disables the comparator resulting in minimum current consumption.

### 16.2.2 COMPARATOR OUTPUT SELECTION

The output of the comparator can be monitored by reading either the CxOUT bit of the CMxCON0 register or the MCxOUT bit of the CMOUT register. In order to make the output available for an external connection, the following conditions must be true:

- Desired pin PPS control
- Corresponding TRIS bit must be cleared
- CxON bit of the CMxCON0 register must be set

**Note 1:** The internal output of the comparator is latched with each instruction cycle. Unless otherwise specified, external outputs are not latched.

### 16.2.3 COMPARATOR OUTPUT POLARITY

Inverting the output of the comparator is functionally equivalent to swapping the comparator inputs. The polarity of the comparator output can be inverted by setting the CxPOL bit of the CMxCON0 register. Clearing the CxPOL bit results in a non-inverted output.

[Table 16-2](#) shows the output state versus input conditions, including polarity control.

**TABLE 16-2: COMPARATOR OUTPUT STATE VS. INPUT CONDITIONS**

Input Condition	CxPOL	CxOUT
$CxVN > CxVP$	0	0
$CxVN < CxVP$	0	1
$CxVN > CxVP$	1	1
$CxVN < CxVP$	1	0

### 16.2.4 COMPARATOR SPEED/POWER SELECTION

The trade-off between speed or power can be optimized during program execution with the CxSP control bit. The default state for this bit is '1', which selects the Normal-Speed mode. Device power consumption can be optimized at the cost of slower comparator propagation delay by clearing the CxSP bit to '0'.

## 16.3 Comparator Hysteresis

A selectable amount of separation voltage can be added to the input pins of each comparator to provide a hysteresis function to the overall operation. Hysteresis is enabled by setting the CxHYS bit of the CMxCON0 register.

See Comparator Specifications in [Table 34-18: Comparator Specifications](#) for more information.

## 16.4 Timer1 Gate Operation

The output resulting from a comparator operation can be used as a source for gate control of Timer1. See [Section 27.6 “Timer1 Gate”](#) for more information. This feature is useful for timing the duration or interval of an analog event.

It is recommended that the comparator output be synchronized to Timer1. This ensures that Timer1 does not increment while a change in the comparator is occurring.

### 16.4.1 COMPARATOR OUTPUT SYNCHRONIZATION

The output from a comparator can be synchronized with Timer1 by setting the CxSYNC bit of the CMxCON0 register.

Once enabled, the comparator output is latched on the falling edge of the Timer1 source clock. If a prescaler is used with Timer1, the comparator output is latched after the prescaling function. To prevent a race condition, the comparator output is latched on the falling edge of the Timer1 clock source and Timer1 increments on the rising edge of its clock source. See the Comparator Block Diagram ([Figure 16-2](#)) and the Timer1 Block Diagram ([Figure 27-1: Timer1 Block Diagram](#)) for more information.

## 16.5 Comparator Interrupt

An interrupt can be generated upon a change in the output value of the comparator for each comparator, a rising edge detector and a falling edge detector are present.

When either edge detector is triggered and its associated enable bit is set (CxINTP and/or CxINTN bits of the CMxCON1 register), the Corresponding Interrupt Flag bit (CxIF bit of the PIR2 register) will be set.

To enable the interrupt, you must set the following bits:

- CxON, CxPOL and CxSP bits of the CMxCON0 register
- CxIE bit of the PIE2 register
- CxINTP bit of the CMxCON1 register (for a rising edge detection)
- CxINTN bit of the CMxCON1 register (for a falling edge detection)
- PEIE and GIE bits of the INTCON register

The associated interrupt flag bit, CxIF bit of the PIR2 register, must be cleared in software. If another edge is detected while this flag is being cleared, the flag will still be set at the end of the sequence.

**Note:** Although a comparator is disabled, an interrupt can be generated by changing the output polarity with the CxPOL bit of the CMxCON0 register, or by switching the comparator on or off with the CxON bit of the CMxCON0 register.

# PIC16(L)F1717/8/9

## 16.6 Comparator Positive Input Selection

Configuring the CxPCH<2:0> bits of the CMxCON1 register directs an internal voltage reference or an analog pin to the non-inverting input of the comparator:

- CxIN+ analog pin
- DAC output
- FVR (Fixed Voltage Reference)
- Vss (Ground)

See [Section 14.0 “Fixed Voltage Reference \(FVR\)”](#) for more information on the Fixed Voltage Reference module.

See [Section 23.0 “8-Bit Digital-to-Analog Converter \(DAC1\) Module”](#) for more information on the DAC input signal.

Any time the comparator is disabled (CxON = 0), all comparator inputs are disabled.

## 16.7 Comparator Negative Input Selection

The CxNCH<2:0> bits of the CMxCON1 register direct an analog input pin and internal reference voltage or analog ground to the inverting input of the comparator:

- CxIN- pin
- FVR (Fixed Voltage Reference)
- Analog Ground

Some inverting input selections share a pin with the operational amplifier output function. Enabling both functions at the same time will direct the operational amplifier output to the comparator inverting input.

**Note:** To use CxINy+ and CxINy- pins as analog input, the appropriate bits must be set in the ANSEL register and the corresponding TRIS bits must also be set to disable the output drivers.

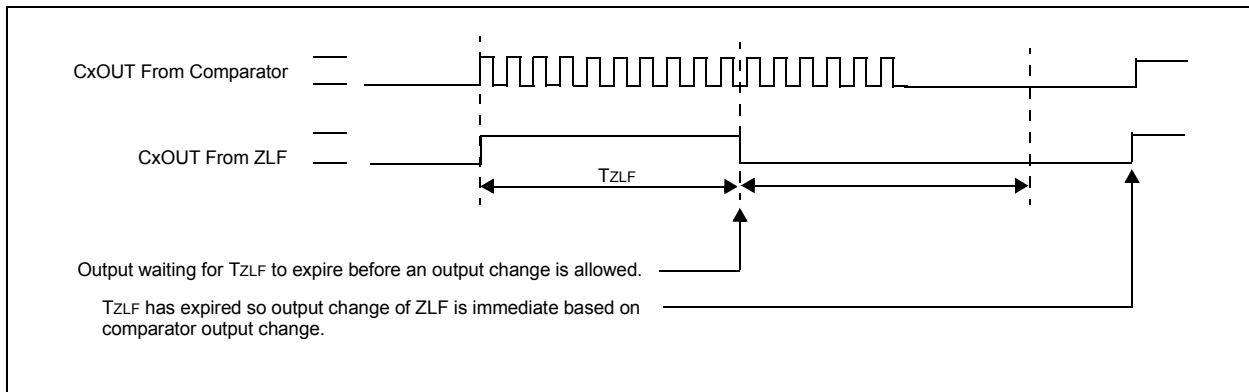
## 16.8 Comparator Response Time

The comparator output is indeterminate for a period of time after the change of an input source or the selection of a new reference voltage. This period is referred to as the response time. The response time of the comparator differs from the settling time of the voltage reference. Therefore, both of these times must be considered when determining the total response time to a comparator input change. See the Comparator and Voltage Reference Specifications in [Table 34-18: Comparator Specifications](#) for more details.

## 16.9 Zero Latency Filter

In high-speed operation, and under proper circuit conditions, it is possible for the comparator output to oscillate. This oscillation can have adverse effects on the hardware and software relying on this signal. Therefore, a digital filter has been added to the comparator output to suppress the comparator output oscillation. Once the comparator output changes, the output is prevented from reversing the change for a nominal time of 20 ns. This allows the comparator output to stabilize without affecting other dependent devices. Refer to [Figure 16-3](#).

**FIGURE 16-3: COMPARATOR ZERO LATENCY FILTER OPERATION**



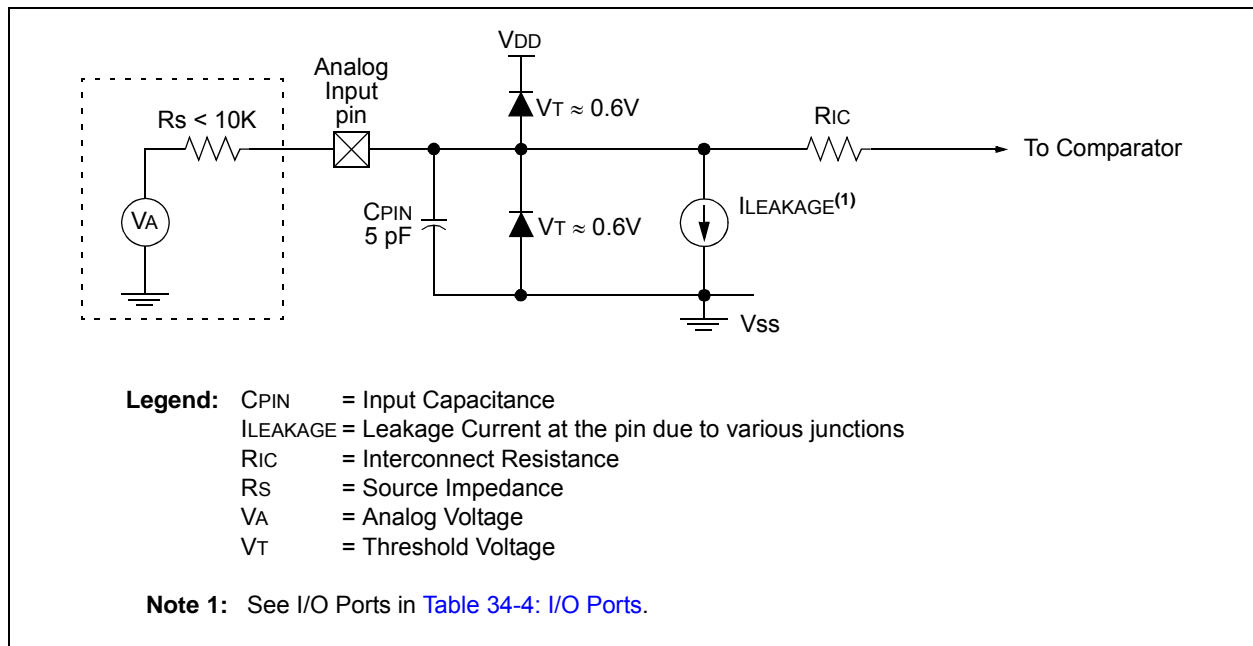
## 16.10 Analog Input Connection Considerations

A simplified circuit for an analog input is shown in Figure 16-4. Since the analog input pins share their connection with a digital input, they have reverse biased ESD protection diodes to  $V_{DD}$  and  $V_{SS}$ . The analog input, therefore, must be between  $V_{SS}$  and  $V_{DD}$ . If the input voltage deviates from this range by more than 0.6V in either direction, one of the diodes is forward biased and a latch-up may occur.

A maximum source impedance of 10 k $\Omega$  is recommended for the analog sources. Also, any external component connected to an analog input pin, such as a capacitor or a Zener diode, should have very little leakage current to minimize inaccuracies introduced.

- Note 1:** When reading a PORT register, all pins configured as analog inputs will read as a '0'. Pins configured as digital inputs will convert as an analog input, according to the input specification.
- 2:** Analog levels on any pin defined as a digital input, may cause the input buffer to consume more current than is specified.

**FIGURE 16-4: ANALOG INPUT MODEL**



# PIC16(L)F1717/8/9

## 16.11 Register Definitions: Comparator Control

REGISTER 16-1: CMxCON0: COMPARATOR Cx CONTROL REGISTER 0

R/W-0/0	R-0/0	U-0	R/W-0/0	R/W-0/0	R/W-1/1	R/W-0/0	R/W-0/0
CxON	CxOUT	—	CxPOL	CxZLF	CxSP	CxHYS	CxSYNC
bit 7							bit 0

**Legend:**

R = Readable bit	W = Writable bit	U = Unimplemented bit, read as '0'
u = Bit is unchanged	x = Bit is unknown	-n/n = Value at POR and BOR/Value at all other Resets
'1' = Bit is set	'0' = Bit is cleared	

- bit 7      **CxON:** Comparator Enable bit  
1 = Comparator is enabled  
0 = Comparator is disabled and consumes no active power
- bit 6      **CxOUT:** Comparator Output bit  
If CxPOL = 1 (inverted polarity):  
1 = CxVP < CxVN  
0 = CxVP > CxVN  
If CxPOL = 0 (non-inverted polarity):  
1 = CxVP > CxVN  
0 = CxVP < CxVN
- bit 5      **Unimplemented:** Read as '0'
- bit 4      **CxPOL:** Comparator Output Polarity Select bit  
1 = Comparator output is inverted  
0 = Comparator output is not inverted
- bit 3      **CxZLF:** Comparator Zero Latency Filter Enable bit  
1 = Comparator output is filtered  
0 = Comparator output is unfiltered
- bit 2      **CxSP:** Comparator Speed/Power Select bit  
1 = Comparator operates in normal power, higher speed mode  
0 = Comparator operates in low-power, low-speed mode
- bit 1      **CxHYS:** Comparator Hysteresis Enable bit  
1 = Comparator hysteresis enabled  
0 = Comparator hysteresis disabled
- bit 0      **CxSYNC:** Comparator Output Synchronous Mode bit  
1 = Comparator output to Timer1 and I/O pin is synchronous to changes on Timer1 clock source.  
    Output updated on the falling edge of Timer1 clock source.  
0 = Comparator output to Timer1 and I/O pin is asynchronous.

## REGISTER 16-2: CMxCON1: COMPARATOR Cx CONTROL REGISTER 1

R/W-0/0	R/W-0/0	R/W-0/0	R/W-0/0	R/W-0/0	R/W-0/0	R/W-0/0	R/W-0/0
CxINTP	CxINTN	CxPCH<2:0>			CxNCH<2:0>		
bit 7							bit 0

### Legend:

R = Readable bit	W = Writable bit	U = Unimplemented bit, read as '0'
u = Bit is unchanged	x = Bit is unknown	-n/n = Value at POR and BOR/Value at all other Resets
'1' = Bit is set	'0' = Bit is cleared	

- bit 7      **CxINTP:** Comparator Interrupt on Positive Going Edge Enable bits  
 1 = The CxIF interrupt flag will be set upon a positive going edge of the CxOUT bit  
 0 = No interrupt flag will be set on a positive going edge of the CxOUT bit
- bit 6      **CxINTN:** Comparator Interrupt on Negative Going Edge Enable bits  
 1 = The CxIF interrupt flag will be set upon a negative going edge of the CxOUT bit  
 0 = No interrupt flag will be set on a negative going edge of the CxOUT bit
- bit 5-3    **CxPCH<2:0>:** Comparator Positive Input Channel Select bits  
 111 = CxVP connects to AGND  
 110 = CxVP connects to FVR Buffer 2  
 101 = CxVP connects to DAC1\_output  
 100 = CxVP connects to DAC2\_output  
 011 = CxVP unconnected, input floating  
 010 = CxVP unconnected, input floating  
 001 = CxVP connects to CxIN1+ pin  
 000 = CxVP connects to CxIN0+ pin
- bit 2-0    **CxNCH<2:0>:** Comparator Negative Input Channel Select bits  
 111 = CxVN connects to AGND  
 110 = CxVN connects to FVR Buffer 2  
 101 = CxVN unconnected, input floating  
 100 = CxVN unconnected, input floating  
 011 = CxVN connects to CxIN3- pin  
 010 = CxVN connects to CxIN2- pin  
 001 = CxVN connects to CxIN1- pin  
 000 = CxVN connects to CxIN0- pin

# PIC16(L)F1717/8/9

**REGISTER 16-3: CMOUT: COMPARATOR OUTPUT REGISTER**

U-0	U-0	U-0	U-0	U-0	U-0	R-0/0	R-0/0
—	—	—	—	—	—	MC2OUT	MC1OUT
bit 7						bit 0	

**Legend:**

R = Readable bit                      W = Writable bit                      U = Unimplemented bit, read as '0'  
u = Bit is unchanged                      x = Bit is unknown                      -n/n = Value at POR and BOR/Value at all other Resets  
'1' = Bit is set                              '0' = Bit is cleared

bit 7-2                      **Unimplemented:** Read as '0'  
bit 1                        **MC2OUT:** Mirror Copy of C2OUT bit  
bit 0                        **MC1OUT:** Mirror Copy of C1OUT bit

**TABLE 16-3: SUMMARY OF REGISTERS ASSOCIATED WITH COMPARATOR MODULE**

Name	Bit 7	Bit 6	Bit 5	Bit 4	Bit 3	Bit 2	Bit 1	Bit 0	Register on Page
ANSELA	—	—	ANSA5	ANSA4	ANSA3	ANSA2	ANSA1	ANSA0	125
ANSELB	—	—	ANSB5	ANSB4	ANSB3	ANSB2	ANSB1	ANSB0	131
CM1CON0	C1ON	C1OUT	—	C1POL	C1ZLF	C1SP	C1HYS	C1SYNC	174
CM2CON0	C2ON	C2OUT	—	C2POL	C2ZLF	C2SP	C2HYS	C2SYNC	174
CM1CON1	C1NTP	C1INTN	C1PCH<2:0>			C1NCH<2:0>			175
CM2CON1	C2NTP	C2INTN	C2PCH<2:0>			C2NCH<2:0>			175
CMOUT	—	—	—	—	—	—	MC2OUT	MC1OUT	176
FVRCON	FVREN	FVRRDY	TSEN	TSRNG	CDAFVR<1:0>		ADFVR<1:0>		165
DAC1CON0	DAC1EN	—	DAC1OE1	DAC1OE2	DAC1PSS<1:0>		—	DAC1NSS	260
DAC1CON1	DAC1R<7:0>								260
INTCON	GIE	PEIE	TMR0IE	INTE	IOCFIE	TMR0IF	INTF	IOCFIF	90
PIE2	OSFIE	C2IE	C1IE	—	BCL1IE	TMR6IE	TMR4IE	CCP2IE	92
PIR2	OSFIF	C2IF	C1IF	—	BCL1IF	TMR6IF	TMR4IF	CCP2IF	95
TRISA	TRISA7	TRISA6	TRISA5	TRISA4	TRISA3	TRISA2	TRISA1	TRISA0	124
TRISB	TRISB7	TRISB6	TRISB5	TRISB4	TRISB3	TRISB2	TRISB1	TRISB0	130
TRISC	TRISC7	TRISC6	TRISC5	TRISC4	TRISC3	TRISC2	TRISC1	TRISC0	135
TRISD <sup>(1)</sup>	TRISD7	TRISD6	TRISD5	TRISD4	TRISD3	TRISD2	TRISD1	TRISD0	140
TRISE	—	—	—	—	TRISE3	TRISE2 <sup>(1)</sup>	TRISE1 <sup>(1)</sup>	TRISE0 <sup>(1)</sup>	145
RxyPPS	—	—	—	RxyPPS<4:0>					153

**Legend:** — = unimplemented location, read as '0'. Shaded cells are unused by the comparator module.

**Note 1:** PIC16(L)F1717/9 only.



## 17.0 PULSE WIDTH MODULATION (PWM)

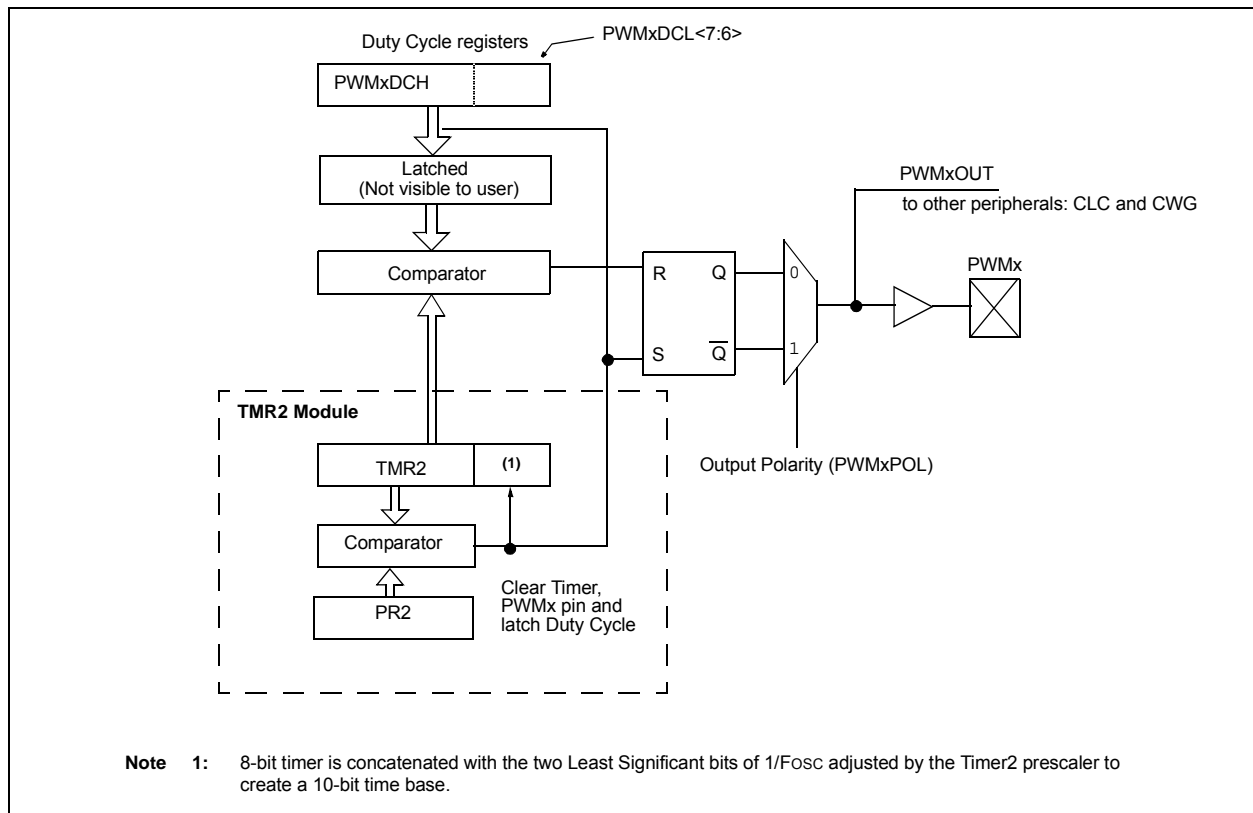
The PWM module generates a Pulse-Width Modulated signal determined by the duty cycle, period, and resolution that are configured by the following registers:

- PR2
- T2CON
- PWMxDCH
- PWMxDCL
- PWMxCON

Figure 17-1 shows a simplified block diagram of PWM operation.

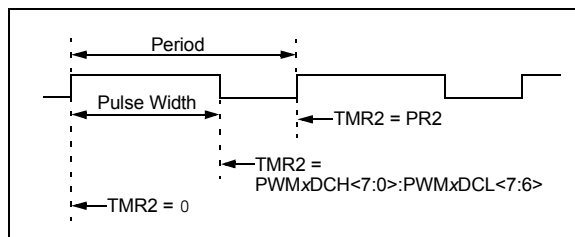
Figure 17-2 shows a typical waveform of the PWM signal.

**FIGURE 17-1: SIMPLIFIED PWM BLOCK DIAGRAM**



For a step-by-step procedure on how to set up this module for PWM operation, refer to [Section 17.1.9](#) “**Setup for PWM Operation Using PWMx Pins**”.

**FIGURE 17-2: PWM OUTPUT**



# PIC16(L)F1717/8/9

## 17.1 PWMx Pin Configuration

All PWM outputs are multiplexed with the PORT data latch. The user must configure the pins as outputs by clearing the associated TRIS bits.

### 17.1.1 FUNDAMENTAL OPERATION

The PWM module produces a 10-bit resolution output. Timer2 and PR2 set the period of the PWM. The PWMxDCL and PWMxDCH registers configure the duty cycle. The period is common to all PWM modules, whereas the duty cycle is independently controlled.

**Note:** The Timer2 postscaler is not used in the determination of the PWM frequency. The postscaler could be used to have a servo update rate at a different frequency than the PWM output.

All PWM outputs associated with Timer2 are set when TMR2 is cleared. Each PWMx is cleared when TMR2 is equal to the value specified in the corresponding PWMxDCH (8 MSb) and PWMxDCL<7:6> (2 LSB) registers. When the value is greater than or equal to PR2, the PWM output is never cleared (100% duty cycle).

**Note:** The PWMxDCH and PWMxDCL registers are double buffered. The buffers are updated when Timer2 matches PR2. Care should be taken to update both registers before the timer match occurs.

### 17.1.2 PWM OUTPUT POLARITY

The output polarity is inverted by setting the PWMxPOL bit of the PWMxCON register.

### 17.1.3 PWM PERIOD

The PWM period is specified by the PR2 register of Timer2. The PWM period can be calculated using the formula of [Equation 17-1](#).

#### EQUATION 17-1: PWM PERIOD

$$PWM\ Period = [(PR2) + 1] \cdot 4 \cdot T_{OSC} \cdot (TMR2\ Prescale\ Value)$$

**Note:**  $T_{OSC} = 1/F_{OSC}$

When TMR2 is equal to PR2, the following three events occur on the next increment cycle:

- TMR2 is cleared
- The PWM output is active. (Exception: When the PWM duty cycle = 0%, the PWM output will remain inactive.)
- The PWMxDCH and PWMxDCL register values are latched into the buffers.

**Note:** The Timer2 postscaler has no effect on the PWM operation.

### 17.1.4 PWM DUTY CYCLE

The PWM duty cycle is specified by writing a 10-bit value to the PWMxDCH and PWMxDCL register pair. The PWMxDCH register contains the eight MSbs and the PWMxDCL<7:6>, the two LSbs. The PWMxDCH and PWMxDCL registers can be written to at any time.

[Equation 17-2](#) is used to calculate the PWM pulse width.

[Equation 17-3](#) is used to calculate the PWM duty cycle ratio.

#### EQUATION 17-2: PULSE WIDTH

$$Pulse\ Width = (PWMxDCH:PWMxDCL<7:6>) \cdot T_{OSC} \cdot (TMR2\ Prescale\ Value)$$

**Note:**  $T_{OSC} = 1/F_{OSC}$

#### EQUATION 17-3: DUTY CYCLE RATIO

$$Duty\ Cycle\ Ratio = \frac{(PWMxDCH:PWMxDCL<7:6>)}{4(PR2 + 1)}$$

The 8-bit timer TMR2 register is concatenated with the two Least Significant bits of  $1/F_{OSC}$ , adjusted by the Timer2 prescaler to create the 10-bit time base. The system clock is used if the Timer2 prescaler is set to 1:1.

## 17.1.5 PWM RESOLUTION

The resolution determines the number of available duty cycles for a given period. For example, a 10-bit resolution will result in 1024 discrete duty cycles, whereas an 8-bit resolution will result in 256 discrete duty cycles.

The maximum PWM resolution is ten bits when PR2 is 255. The resolution is a function of the PR2 register value as shown by [Equation 17-4](#).

### EQUATION 17-4: PWM RESOLUTION

$$Resolution = \frac{\log[4(PR2 + 1)]}{\log(2)} \text{ bits}$$

Note: If the pulse width value is greater than the period the assigned PWM pin(s) will remain unchanged.

**TABLE 17-1: EXAMPLE PWM FREQUENCIES AND RESOLUTIONS (Fosc = 20 MHz)**

PWM Frequency	0.31 kHz	4.88 kHz	19.53 kHz	78.12 kHz	156.3 kHz	208.3 kHz
Timer Prescale	64	4	1	1	1	1
PR2 Value	0xFF	0xFF	0xFF	0x3F	0x1F	0x17
Maximum Resolution (bits)	10	10	10	8	7	6.6

**TABLE 17-2: EXAMPLE PWM FREQUENCIES AND RESOLUTIONS (Fosc = 8 MHz)**

PWM Frequency	0.31 kHz	4.90 kHz	19.61 kHz	76.92 kHz	153.85 kHz	200.0 kHz
Timer Prescale	64	4	1	1	1	1
PR2 Value	0x65	0x65	0x65	0x19	0x0C	0x09
Maximum Resolution (bits)	8	8	8	6	5	5

## 17.1.6 OPERATION IN SLEEP MODE

In Sleep mode, the TMR2 register will not increment and the state of the module will not change. If the PWMx pin is driving a value, it will continue to drive that value. When the device wakes up, TMR2 will continue from its previous state.

## 17.1.7 CHANGES IN SYSTEM CLOCK FREQUENCY

The PWM frequency is derived from the system clock frequency (Fosc). Any changes in the system clock frequency will result in changes to the PWM frequency. Refer to [Section 6.0 “Oscillator Module \(with Fail-Safe Clock Monitor\)”](#) for additional details.

## 17.1.8 EFFECTS OF RESET

Any Reset will force all ports to Input mode and the PWM registers to their Reset states.

# PIC16(L)F1717/8/9

## 17.1.9 SETUP FOR PWM OPERATION USING PWMx PINS

The following steps should be taken when configuring the module for PWM operation using the PWMx pins:

1. Disable the PWMx pin output driver(s) by setting the associated TRIS bit(s).
2. Clear the PWMxCON register.
3. Load the PR2 register with the PWM period value.
4. Load the PWMxDCH register and bits <7:6> of the PWMxDCL register with the PWM duty cycle value.
5. Configure and start Timer2:
  - Clear the TMR2IF interrupt flag bit of the PIR1 register. See Note below.
  - Configure the T2CKPS bits of the T2CON register with the Timer2 prescale value.
  - Enable Timer2 by setting the TMR2ON bit of the T2CON register.
6. Enable PWM output pin and wait until Timer2 overflows, TMR2IF bit of the PIR1 register is set. See Note below.
7. Enable the PWMx pin output driver(s) by clearing the associated TRIS bit(s) and setting the desired pin PPS control bits.
8. Configure the PWM module by loading the PWMxCON register with the appropriate values.

**Note 1:** In order to send a complete duty cycle and period on the first PWM output, the above steps must be followed in the order given. If it is not critical to start with a complete PWM signal, then move Step 8 to replace Step 4.

**2:** For operation with other peripherals only, disable PWMx pin outputs.

## 17.1.10 SETUP FOR PWM OPERATION TO OTHER DEVICE PERIPHERALS

The following steps should be taken when configuring the module for PWM operation to be used by other device peripherals:

1. Disable the PWMx pin output driver(s) by setting the associated TRIS bit(s).
2. Clear the PWMxCON register.
3. Load the PR2 register with the PWM period value.
4. Load the PWMxDCH register and bits <7:6> of the PWMxDCL register with the PWM duty cycle value.
5. Configure and start Timer2:
  - Clear the TMR2IF interrupt flag bit of the PIR1 register. See Note below.
  - Configure the T2CKPS bits of the T2CON register with the Timer2 prescale value.
  - Enable Timer2 by setting the TMR2ON bit of the T2CON register.
6. Enable PWM output pin:
  - Wait until Timer2 overflows, TMR2IF bit of the PIR1 register is set. See Note below.
7. Configure the PWM module by loading the PWMxCON register with the appropriate values.

**Note:** In order to send a complete duty cycle and period on the first PWM output, the above steps must be included in the setup sequence. If it is not critical to start with a complete PWM signal on the first output, then step 6 may be ignored.

## 17.2 Register Definitions: PWM Control

**REGISTER 17-1: PWMxCON: PWM CONTROL REGISTER**

R/W-0/0	U-0	R-0/0	R/W-0/0	U-0	U-0	U-0	U-0
PWMxEN	—	PWMxOUT	PWMxPOL	—	—	—	—
bit 7							bit 0

**Legend:**

R = Readable bit                      W = Writable bit                      U = Unimplemented bit, read as '0'  
u = Bit is unchanged                  x = Bit is unknown                  -n/n = Value at POR and BOR/Value at all other Resets  
'1' = Bit is set                            '0' = Bit is cleared

- bit 7            **PWMxEN:** PWM Module Enable bit  
                  1 = PWM module is enabled  
                  0 = PWM module is disabled
- bit 6            **Unimplemented:** Read as '0'
- bit 5            **PWMxOUT:** PWM module output level when bit is read.
- bit 4            **PWMxPOL:** PWMx Output Polarity Select bit  
                  1 = PWM output is active low.  
                  0 = PWM output is active high.
- bit 3-0        **Unimplemented:** Read as '0'

**REGISTER 17-2: PWMxDCH: PWM DUTY CYCLE HIGH BITS**

R/W-x/u	R/W-x/u	R/W-x/u	R/W-x/u	R/W-x/u	R/W-x/u	R/W-x/u	R/W-x/u
PWMxDCH<7:0>							
bit 7							bit 0

**Legend:**

R = Readable bit                      W = Writable bit                      U = Unimplemented bit, read as '0'  
u = Bit is unchanged                  x = Bit is unknown                  -n/n = Value at POR and BOR/Value at all other Resets  
'1' = Bit is set                            '0' = Bit is cleared

- bit 7-0        **PWMxDCH<7:0>:** PWM Duty Cycle Most Significant bits  
                  These bits are the MSBs of the PWM duty cycle. The two LSBs are found in PWMxDCL Register.

**REGISTER 17-3: PWMxDCL: PWM DUTY CYCLE LOW BITS**

R/W-x/u	R/W-x/u	U-0	U-0	U-0	U-0	U-0	U-0
PWMxDCL<7:6>		—	—	—	—	—	—
bit 7							bit 0

**Legend:**

R = Readable bit                      W = Writable bit                      U = Unimplemented bit, read as '0'  
u = Bit is unchanged                  x = Bit is unknown                  -n/n = Value at POR and BOR/Value at all other Resets  
'1' = Bit is set                            '0' = Bit is cleared

- bit 7-6        **PWMxDCL<7:6>:** PWM Duty Cycle Least Significant bits  
                  These bits are the LSBs of the PWM duty cycle. The MSBs are found in PWMxDCH Register.
- bit 5-0        **Unimplemented:** Read as '0'

# PIC16(L)F1717/8/9

**TABLE 17-3: SUMMARY OF REGISTERS ASSOCIATED WITH PWM**

Name	Bit 7	Bit 6	Bit 5	Bit 4	Bit 3	Bit 2	Bit 1	Bit 0	Register on Page
CCPTMRS	P4TSEL<1:0>		P3TSEL<1:0>		C2TSEL<1:0>		C1TSEL<1:0>		286
PR2	Timer2 module Period Register								282
PWM3CON	PWM3EN	—	PWM3OUT	PWM3POL	—	—	—	—	181
PWM3DCH	PWM3DCH<7:0>								181
PWM3DCL	PWM3DCL<1:0>		—	—	—	—	—	—	181
PWM4CON	PWM4EN	—	PWM4OUT	PWM4POL	—	—	—	—	181
PWM4DCH	PWM4DCH<7:0>								181
PWM4DCL	PWM4DCL<1:0>		—	—	—	—	—	—	181
TRISA	TRISA7	TRISA6	TRISA5	TRISA4	TRISA3	TRISA2	TRISA1	TRISA0	124
TRISB	TRISB7	TRISB6	TRISB5	TRISB4	TRISB3	TRISB2	TRISB1	TRISB0	130
TRISC	TRISC7	TRISC6	TRISC5	TRISC4	TRISC3	TRISC2	TRISC1	TRISC0	135
TRISD <sup>(1)</sup>	TRISD7	TRISD6	TRISD5	TRISD4	TRISD3	TRISD2	TRISD1	TRISD0	140
TRISE	—	—	—	—	TRISE3	TRISE2 <sup>(1)</sup>	TRISE1 <sup>(1)</sup>	TRISE0 <sup>(1)</sup>	145
RxyPPS	—	—	—	RxyPPS<4:0>				153	
T2CON	—	T2OUTPS<3:0>			TMR2ON	T2CKPS<1:0>			284
TMR2	Timer2 module Register								282

**Legend:** — = Unimplemented locations, read as '0', u = unchanged, x = unknown. Shaded cells are not used by the PWM.

**Note 1:** PIC16(L)F1717/9 only.



## 18.0 COMPLEMENTARY OUTPUT GENERATOR (COG) MODULE

The primary purpose of the Complementary Output Generator (COG) is to convert a single output PWM signal into a two output complementary PWM signal. The COG can also convert two separate input events into a single or complementary PWM output.

The COG PWM frequency and duty cycle are determined by a rising event input and a falling event input. The rising event and falling event may be the same source. Sources may be synchronous or asynchronous to the COG\_clock.

The rate at which the rising event occurs determines the PWM frequency. The time from the rising event input to the falling event input determines the duty cycle.

A selectable clock input is used to generate the phase delay, blanking, and dead-band times. Dead-band time can also be generated with a programmable time delay, which is independent from all clock sources.

Simplified block diagrams of the various COG modes are shown in [Figure 18-2](#) through [Figure 18-6](#).

The COG module has the following features:

- Six modes of operation:
  - Steered PWM mode
  - Synchronous Steered PWM mode
  - Forward Full-Bridge mode
  - Reverse Full-Bridge mode
  - Half-Bridge mode
  - Push-Pull mode
- Selectable COG\_clock clock source
- Independently selectable rising event sources
- Independently selectable falling event sources
- Independently selectable edge or level event sensitivity
- Independent output polarity selection
- Phase delay with independent rising and falling delay times
- Dead-band control with:
  - independent rising and falling event dead-band times
  - Synchronous and asynchronous timing
- Blanking control with independent rising and falling event blanking times
- Auto-shutdown control with:
  - Independently selectable shutdown sources
  - Auto-restart enable
  - Auto-shutdown pin override control (high, low, off, and High-Z)

## 18.1 Fundamental Operation

### 18.1.1 STEERED PWM MODES

In steered PWM mode, the PWM signal derived from the input event sources is output as a single phase PWM which can be steered to any combination of the four COG outputs. Outputs are selected by setting the GxSTRA through GxSTRD bits of the COGxSTR register ([Register 18-9](#)). When the steering bits are cleared, then the output data is the static level determined by the GxSDATA through GxSDATD bits of the COGxSTR register. Output steering takes effect on the instruction cycle following the write to the COGxSTR register.

Synchronous steered PWM mode is identical to the steered PWM mode except that changes to the output steering take effect on the first rising event after the COGxSTR register write. Static output data is not synchronized.

Steering mode configurations are shown in [Figure 18-2](#) and [Figure 18-3](#).

Steered PWM and synchronous steered PWM modes are selected by setting the GxMD bits of the COGxCON0 register ([Register 18-1](#)) to '000' and '001' respectively.

### 18.1.2 FULL-BRIDGE MODES

In both Forward and Reverse Full-Bridge modes, two of the four COG outputs are active and the other two are inactive. Of the two active outputs, one is modulated by the PWM input signal and the other is on at 100% duty cycle. When the direction is changed, the dead-band time is inserted to delay the modulated output. This gives the unmodulated driver time to shut down, thereby, preventing shoot-through current in the series connected power devices.

In Forward Full-Bridge mode, the PWM input modulates the COGxD output and drives the COGA output at 100%.

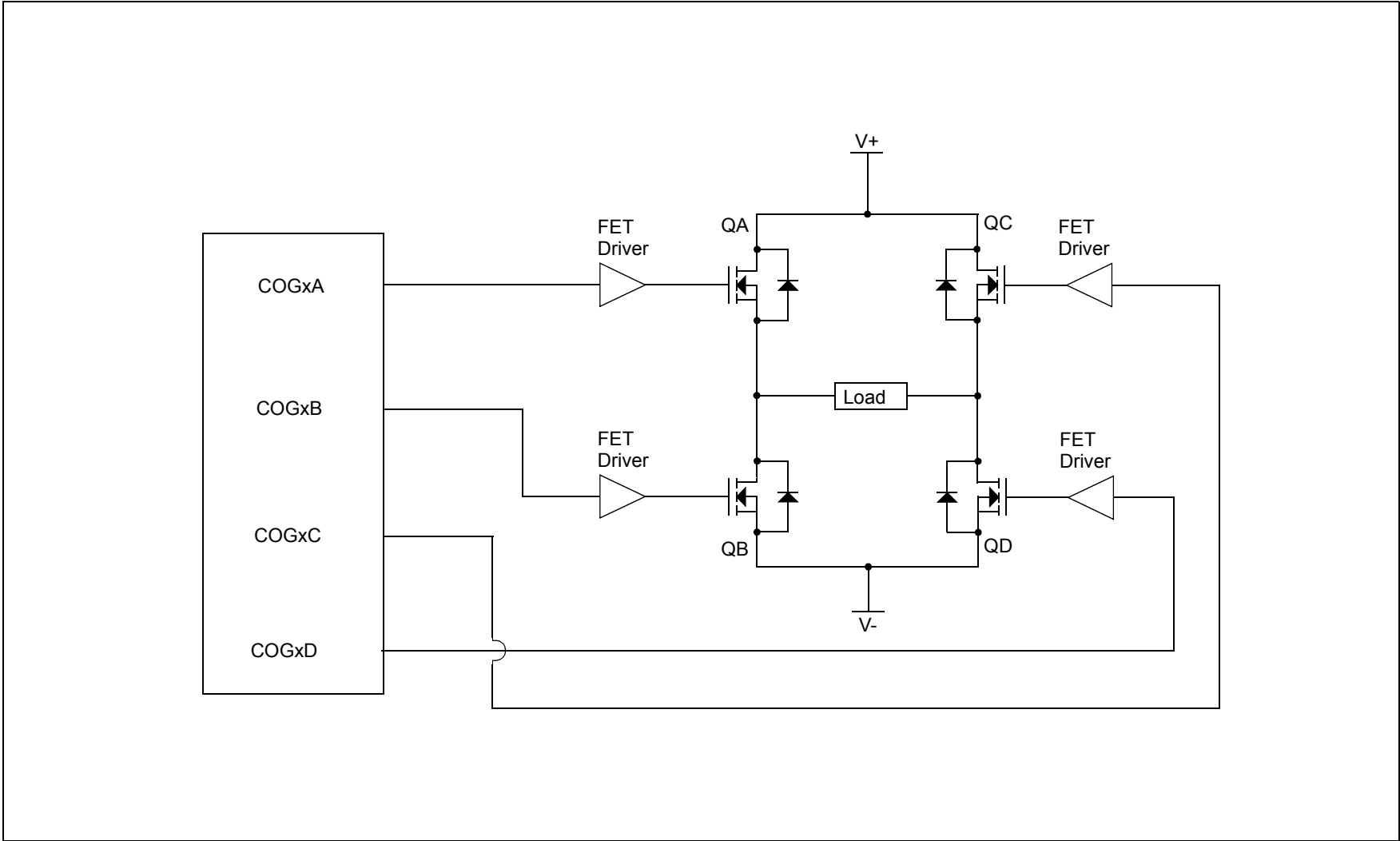
In Reverse Full-Bridge mode, the PWM input modulates the COGxB output and drives the COGxC output at 100%.

The full-bridge configuration is shown in [Figure 18-4](#). Typical full-bridge waveforms are shown in [Figure 18-12](#) and [Figure 18-13](#).

Full-Bridge Forward and Full-Bridge Reverse modes are selected by setting the GxMD bits of the COGxCON0 register to '010' and '011', respectively.



**FIGURE 18-1: EXAMPLE OF FULL-BRIDGE APPLICATION**



# PIC16(L)F1717/8/9

---

## 18.1.3 HALF-BRIDGE MODE

In half-bridge mode, the COG generates a two output complementary PWM waveform from rising and falling event sources. In the simplest configuration, the rising and falling event sources are the same signal, which is a PWM signal with the desired period and duty cycle. The COG converts this single PWM input into a dual complementary PWM output. The frequency and duty cycle of the dual PWM output match those of the single input PWM signal. The off-to-on transition of each output can be delayed from the on-to-off transition of the other output, thereby, creating a time immediately after the PWM transition where neither output is driven. This is referred to as dead time and is covered in [Section 18.5 “Dead-Band Control”](#).

A typical operating waveform, with dead band, generated from a single CCP1 input is shown in [Figure 18-9](#).

The primary output can be steered to either or both COGxA and COGxC. The complementary output can be steered to either or both COGxB and COGD.

Half-Bridge mode is selected by setting the GxMD bits of the COGxCON0 register to ‘100’.

## 18.1.4 PUSH-PULL MODE

In Push-Pull mode, the COG generates a single PWM output that alternates, every PWM period, between the two pairs of the COG outputs. COGxA has the same signal as COGxC. COGxB has the same signal as COGD. The output drive activates with the rising input event and terminates with the falling event input. Each rising event starts a new period and causes the output to switch to the COG pair not used in the previous period.

The push-pull configuration is shown in [Figure 18-6](#). A typical push-pull waveform generated from a single CCP1 input is shown in [Figure 18-11](#).

Push-Pull mode is selected by setting the GxMD bits of the COGxCON0 register to ‘101’.

## 18.1.5 EVENT DRIVEN PWM (ALL MODES)

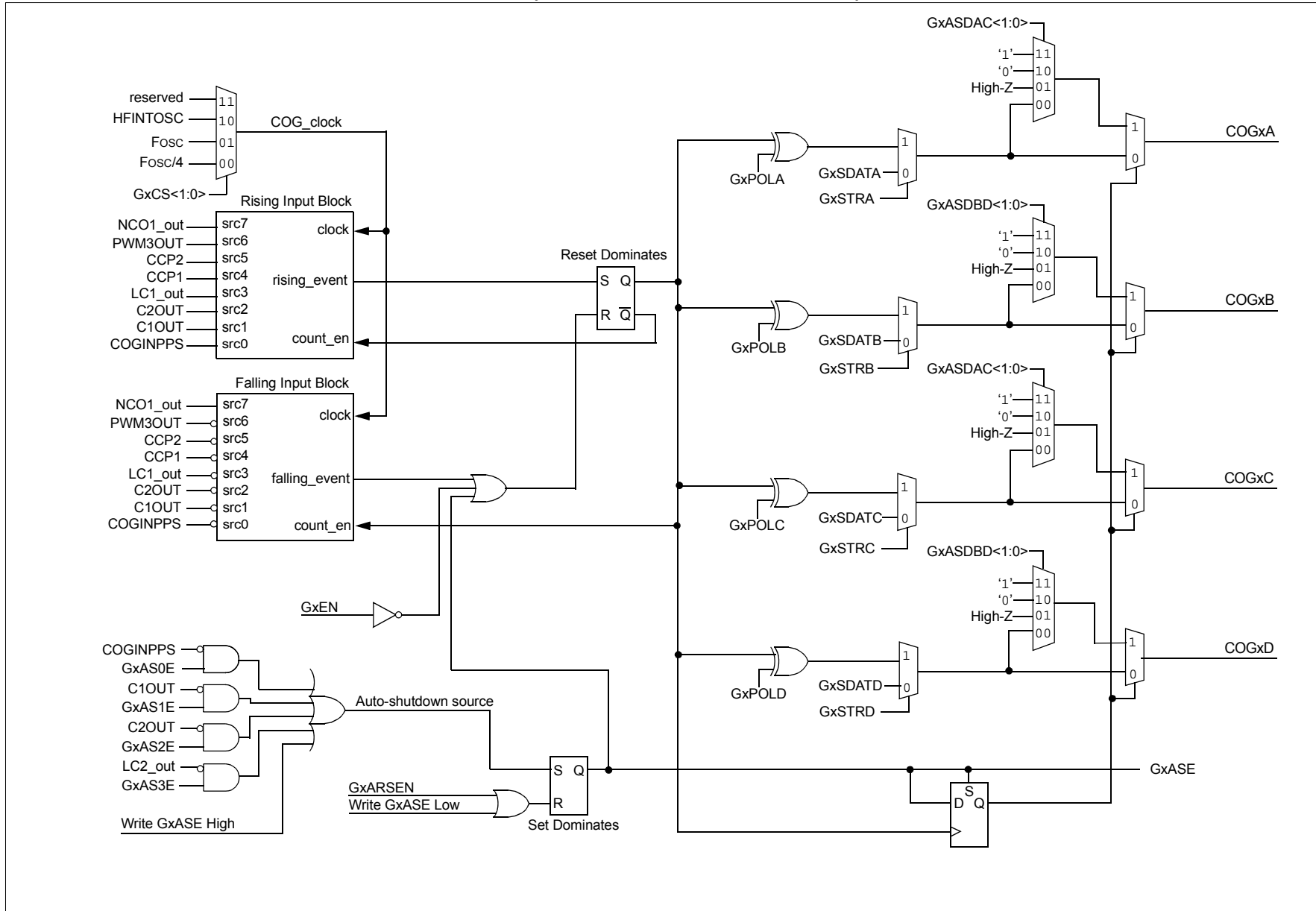
Besides generating PWM and complementary outputs from a single PWM input, the COG can also generate PWM waveforms from a periodic rising event and a separate falling event. In this case, the falling event is usually derived from analog feedback within the external PWM driver circuit. In this configuration, high power switching transients may trigger a false falling event that needs to be blanked out. The COG can be configured to blank falling (and rising) event inputs for a period of time immediately following the rising (and falling) event drive output. This is referred to as input blanking and is covered in [Section 18.6 “Blanking Control”](#).

It may be necessary to guard against the possibility of circuit faults. In this case, the active drive must be terminated before the Fault condition causes damage. This is referred to as auto-shutdown and is covered in [Section 18.8 “Auto-shutdown Control”](#).

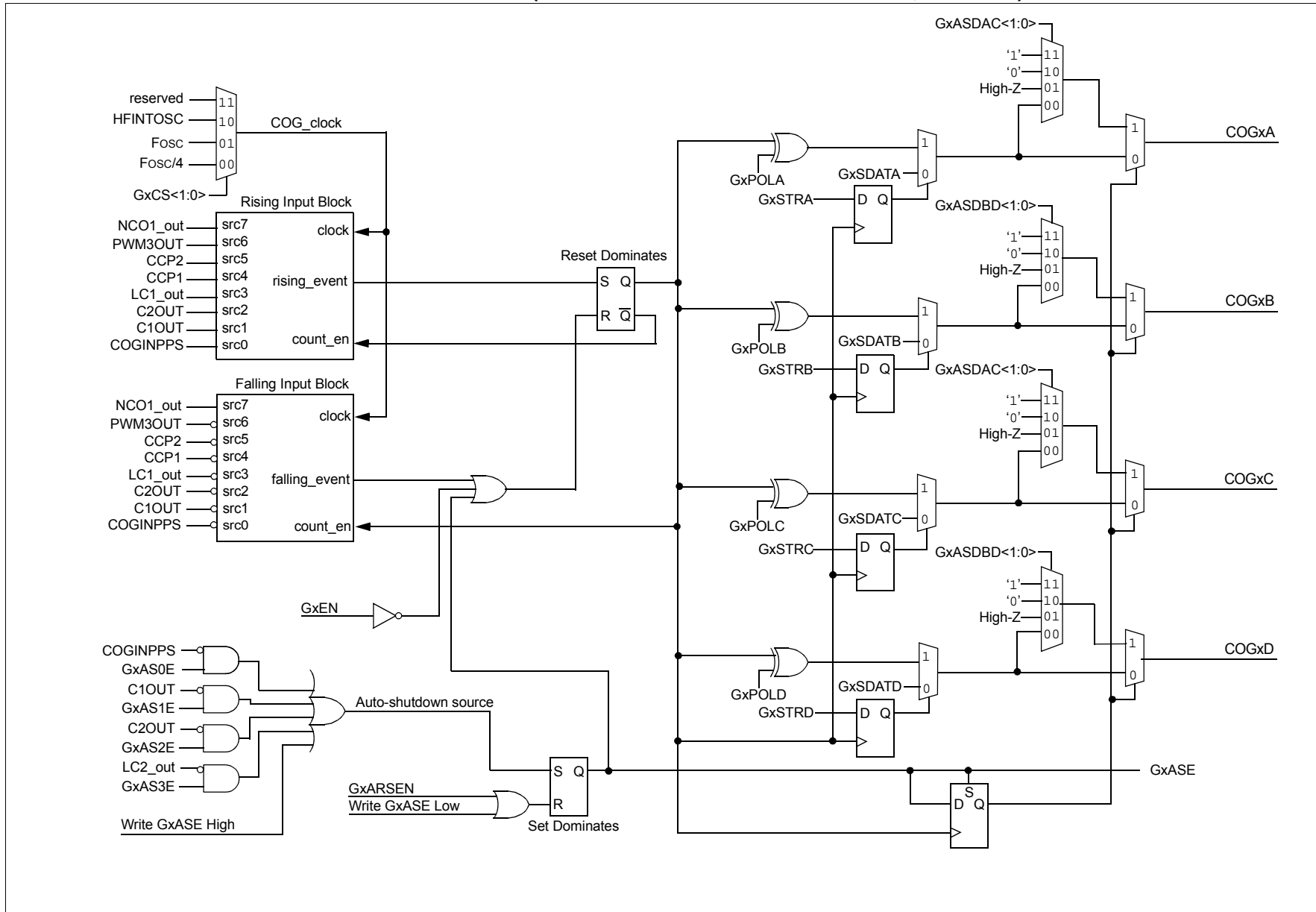
The COG can be configured to operate in phase delayed conjunction with another PWM. The active drive cycle is delayed from the rising event by a phase delay timer. Phase delay is covered in more detail in [Section 18.7 “Phase Delay”](#).

A typical operating waveform, with phase delay and dead band, generated from a single CCP1 input is shown in [Figure 18-10](#).

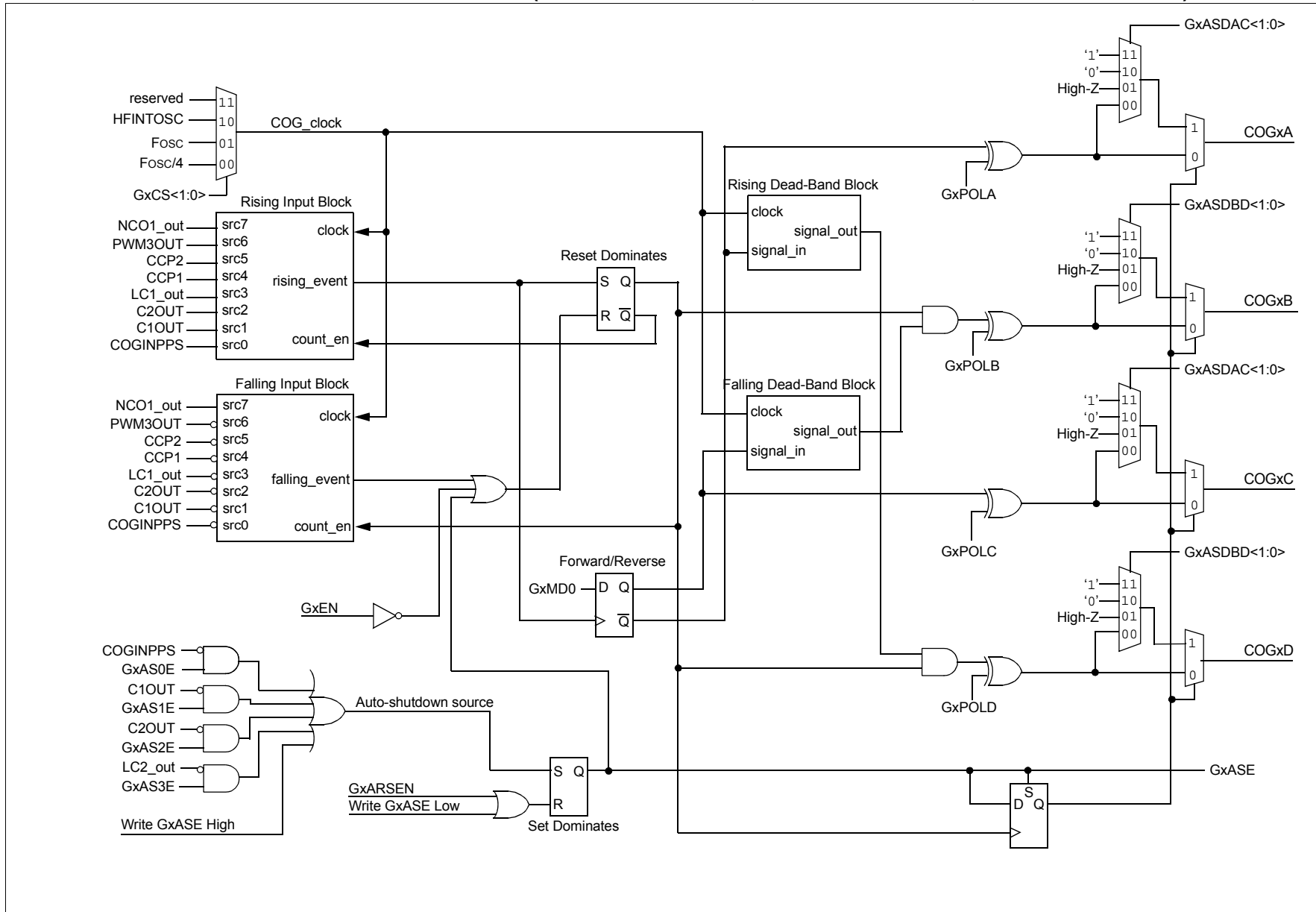
FIGURE 18-2: SIMPLIFIED COG BLOCK DIAGRAM (STEERED PWM MODE, GXMD = 0)



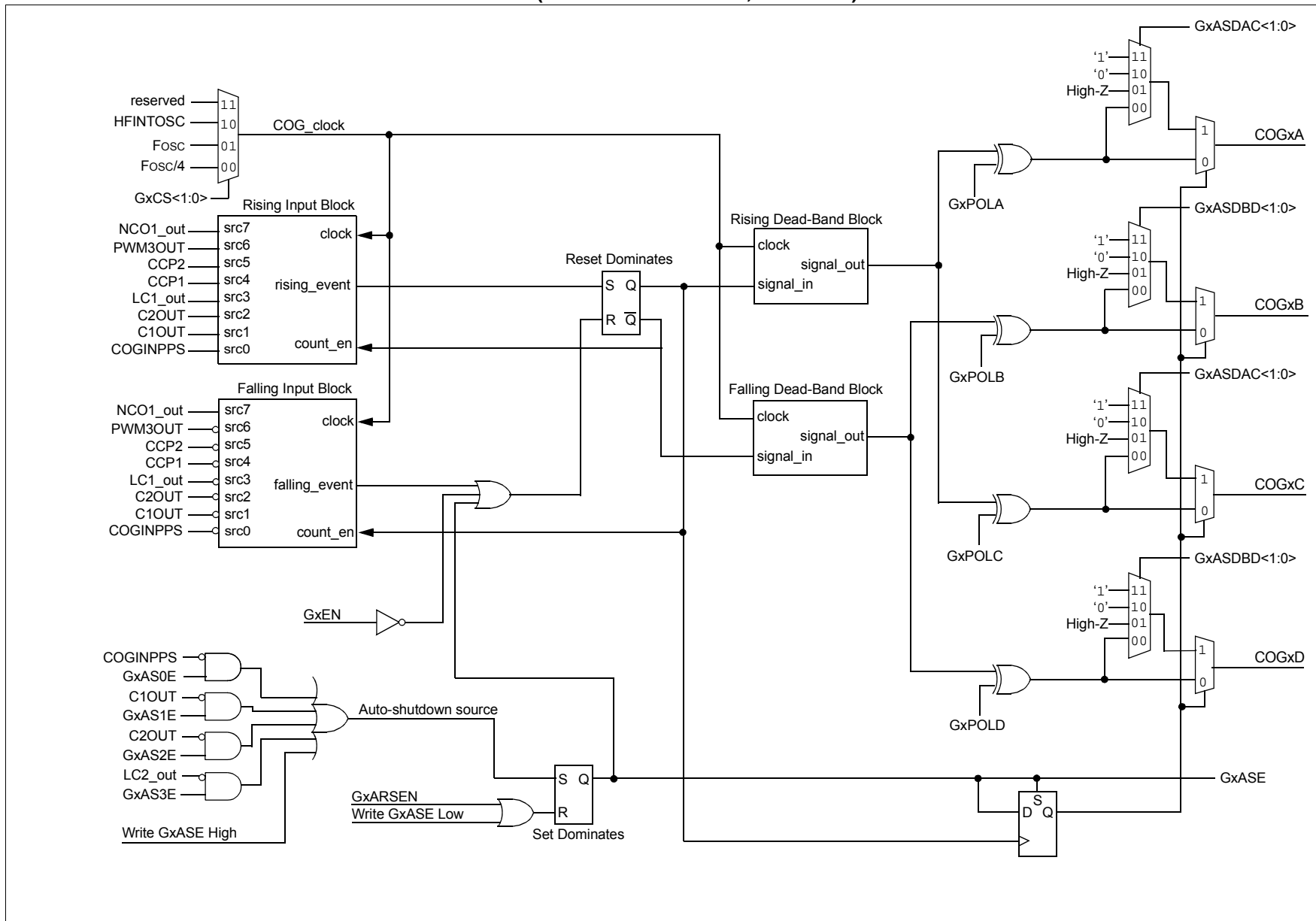
**FIGURE 18-3: SIMPLIFIED COG BLOCK DIAGRAM (SYNCHRONOUS STEERED PWM MODE, GXMD = 1)**



**FIGURE 18-4: SIMPLIFIED COG BLOCK DIAGRAM (FULL-BRIDGE MODES, FORWARD: GXMD = 2, REVERSE: GXMD = 3)**



**FIGURE 18-5: SIMPLIFIED COG BLOCK DIAGRAM (HALF-BRIDGE MODE, GXMD = 4)**



**FIGURE 18-6: SIMPLIFIED COG BLOCK DIAGRAM (PUSH-PULL MODE, GXMD = 5)**

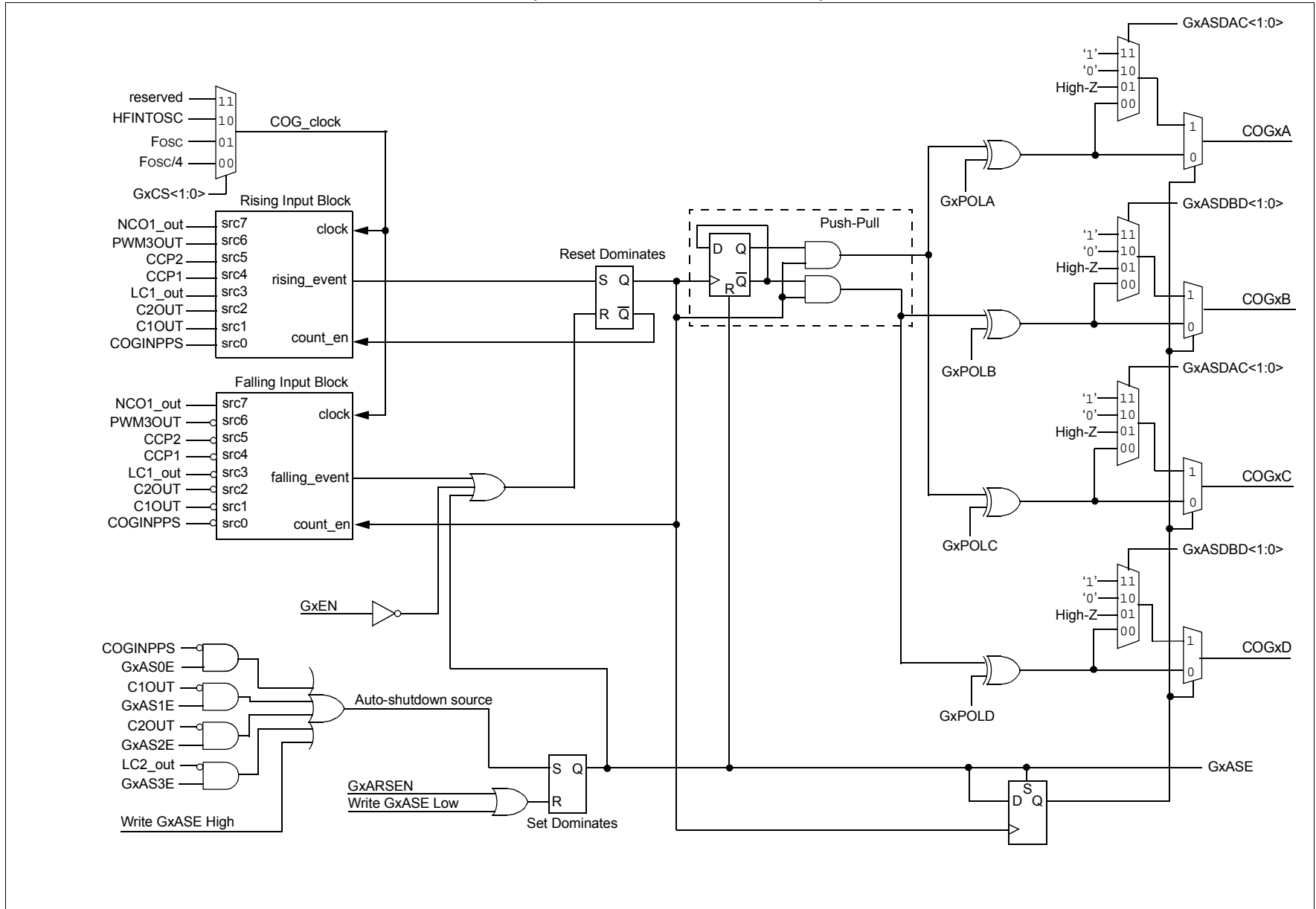


FIGURE 18-7: COG (RISING/FALLING) INPUT BLOCK

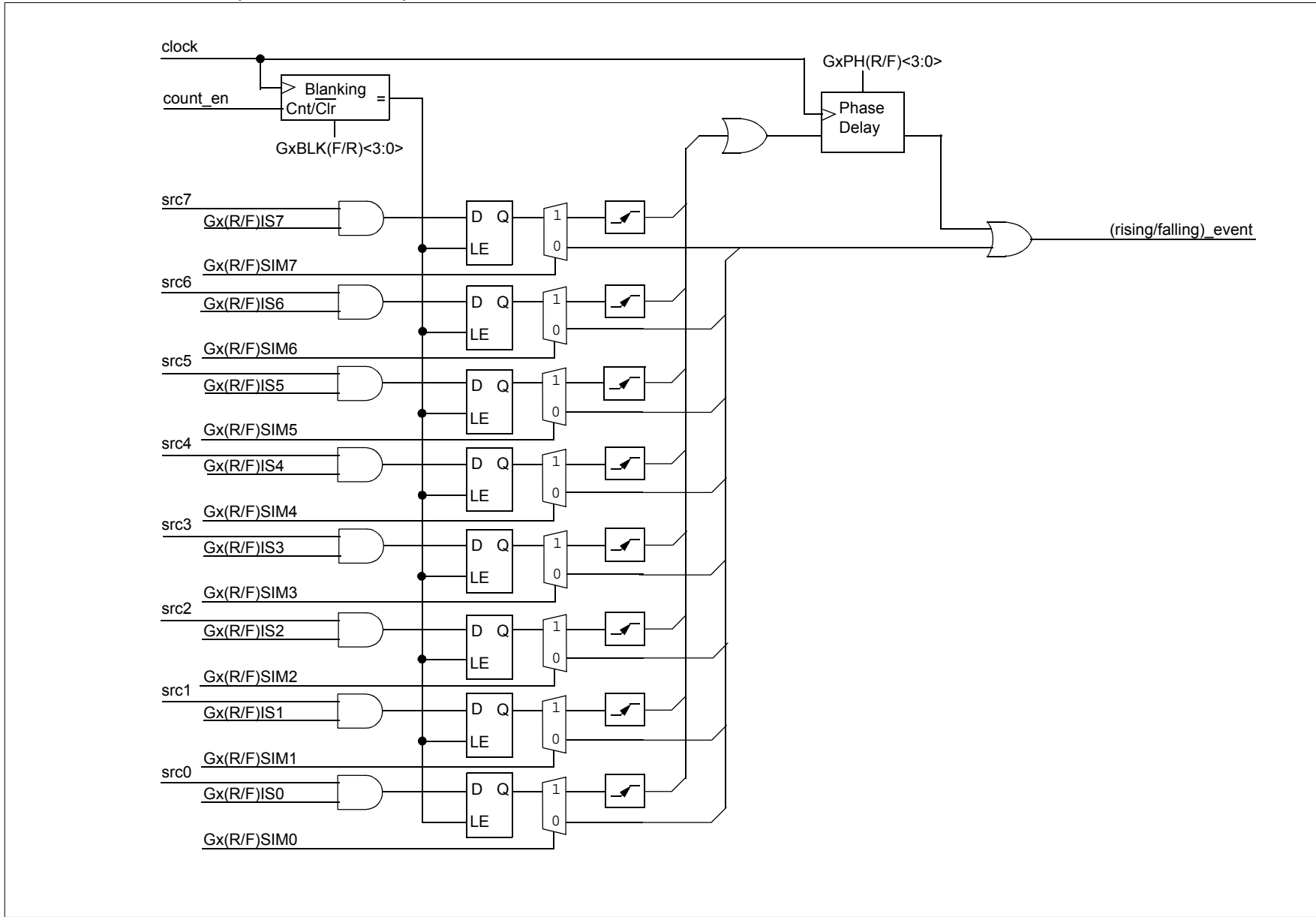
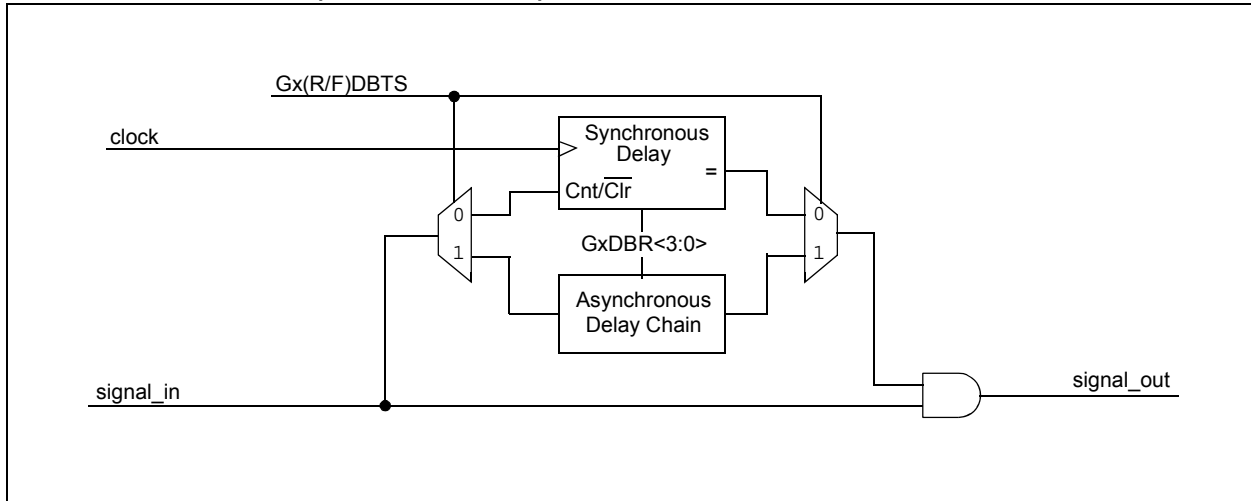


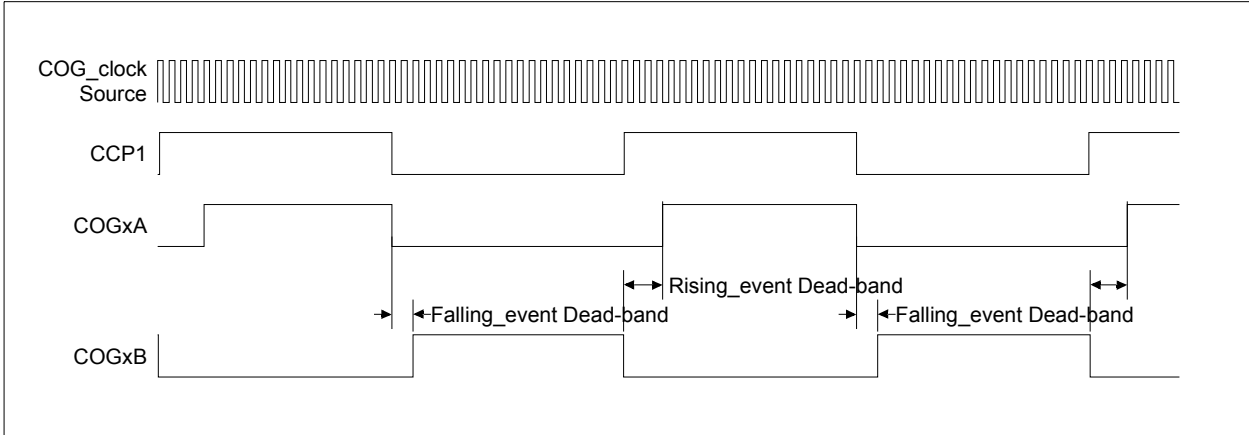


FIGURE 18-8: COG (RISING/FALLING) DEAD-BAND BLOCK

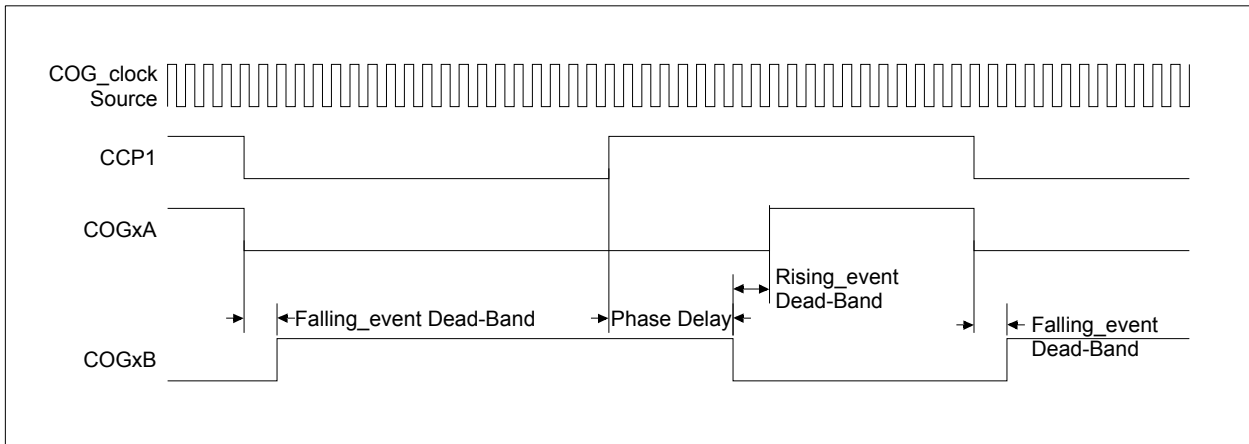


# PIC16(L)F1717/8/9

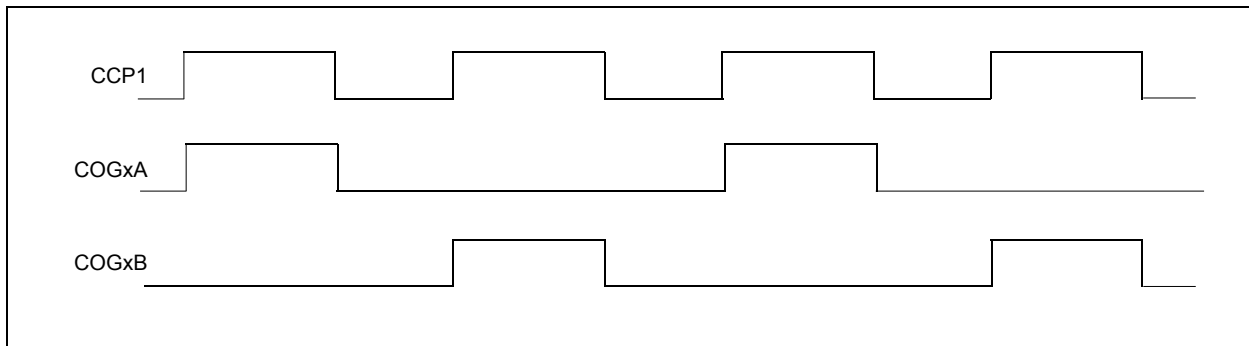
**FIGURE 18-9: TYPICAL HALF-BRIDGE MODE COG OPERATION WITH CCP1**



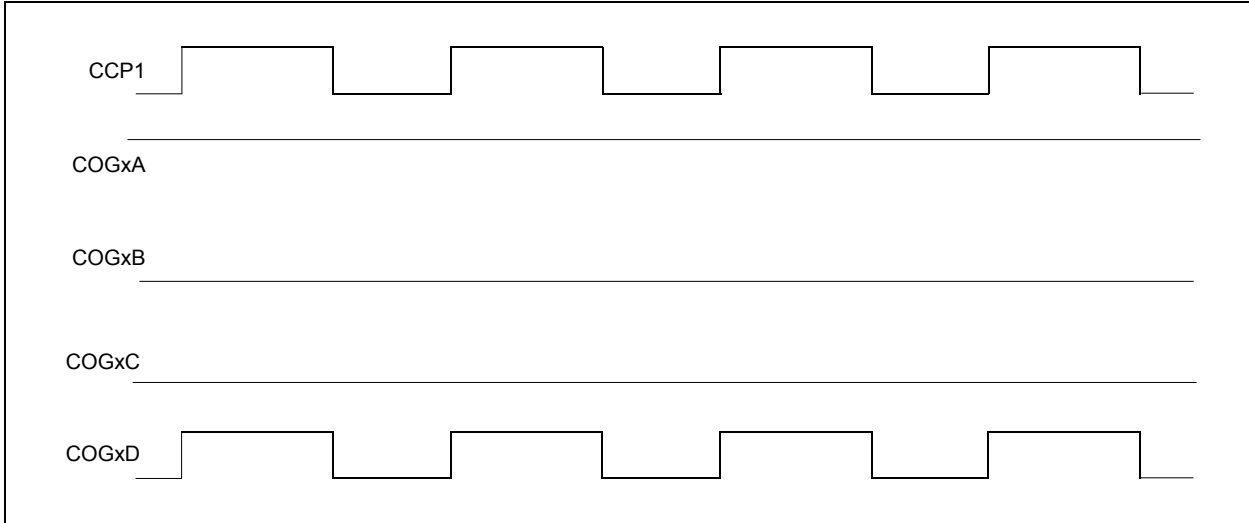
**FIGURE 18-10: HALF-BRIDGE MODE COG OPERATION WITH CCP1 AND PHASE DELAY**



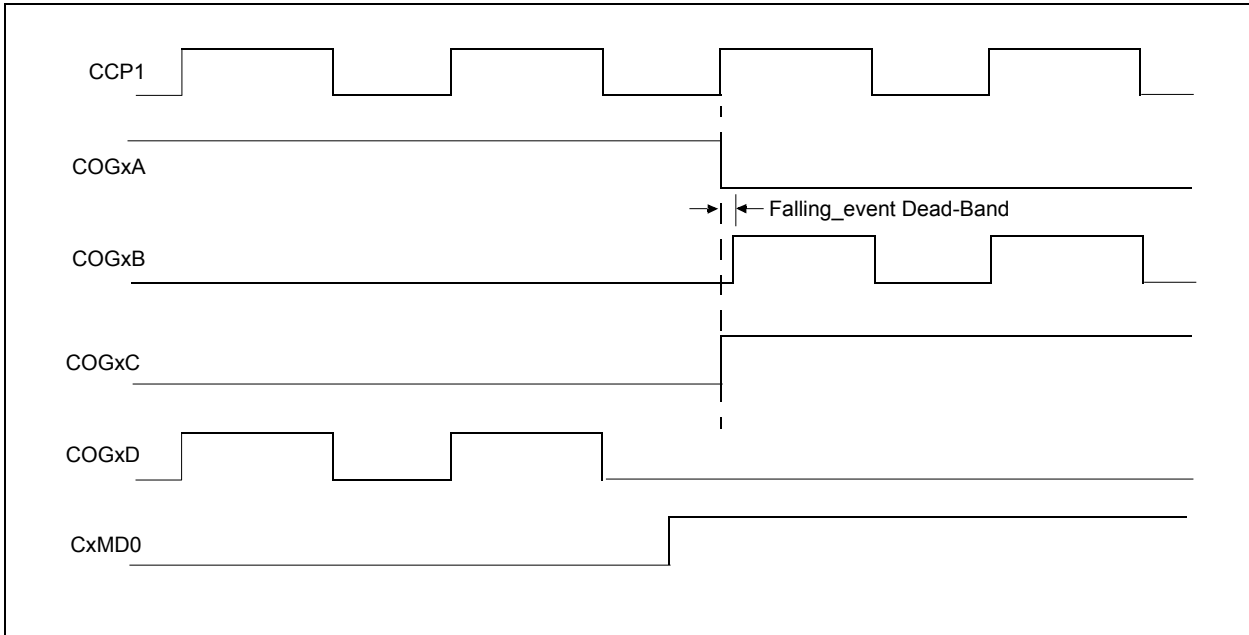
**FIGURE 18-11: PUSH-PULL MODE COG OPERATION WITH CCP1**



**FIGURE 18-12: FULL-BRIDGE FORWARD MODE COG OPERATION WITH CCP1**



**FIGURE 18-13: FULL-BRIDGE MODE COG OPERATION WITH CCP1 AND DIRECTION CHANGE**



# PIC16(L)F1717/8/9

## 18.2 Clock Sources

The COG\_clock is used as the reference clock to the various timers in the peripheral. Timers that use the COG\_clock include:

- Rising and falling dead-band time
- Rising and falling blanking time
- Rising and falling event phase delay

Clock sources available for selection include:

- 8 MHz HFINTOSC (active during Sleep)
- Instruction clock (Fosc/4)
- System clock (Fosc)

The clock source is selected with the GxCS<1:0> bits of the COGxCON0 register ([Register 18-1](#)).

## 18.3 Selectable Event Sources

The COG uses any combination of independently selectable event sources to generate the complementary waveform. Sources fall into two categories:

- Rising event sources
- Falling event sources

The rising event sources are selected by setting bits in the COGxRIS register ([Register 18-3](#)). The falling event sources are selected by setting bits in the COGxFIS register ([Register 18-5](#)). All selected sources are 'OR'd together to generate the corresponding event signal. Refer to [Figure 18-7](#).

### 18.3.1 EDGE VS. LEVEL SENSING

Event input detection may be selected as level or edge sensitive. The detection mode is individually selectable for every source. Rising source detection modes are selected with the COGxRSIM register ([Register 18-4](#)). Falling source detection modes are selected with the COGxFSIM register ([Register 18-6](#)). A set bit enables edge detection for the corresponding event source. A cleared bit enables level detection.

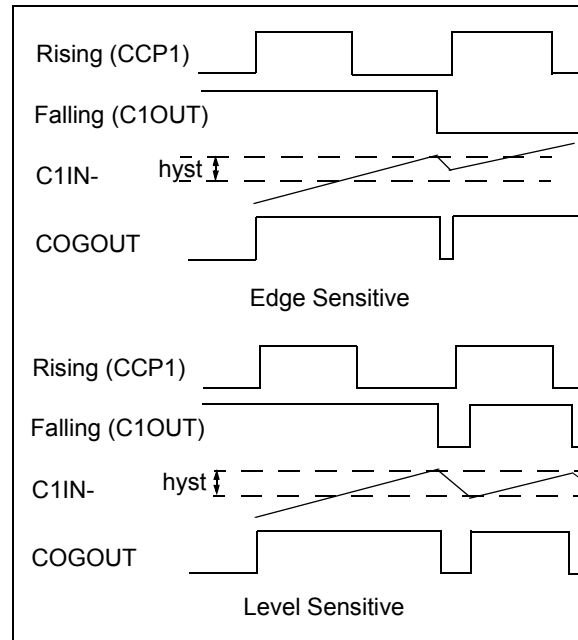
In general, events that are driven from a periodic source should be edge detected and events that are derived from voltage thresholds at the target circuit should be level sensitive. Consider the following two examples:

1. The first example is an application in which the period is determined by a 50% duty cycle clock and the COG output duty cycle is determined by a voltage level fed back through a comparator. If the clock input is level sensitive, duty cycles less than 50% will exhibit erratic operation.

2. The second example is similar to the first except that the duty cycle is close to 100%. The feedback comparator high-to-low transition trips the COG drive off, but almost immediately the period source turns the drive back on. If the off cycle is short enough, the comparator input may not reach the low side of the hysteresis band

precluding an output change. The comparator output stays low and without a high-to-low transition to trigger the edge sense, the drive of the COG output will be stuck in a constant drive-on condition. See [Figure 18-14](#).

**FIGURE 18-14: EDGE VS LEVEL SENSE**



### 18.3.2 RISING EVENT

The rising event starts the PWM output active duty cycle period. The rising event is the low-to-high transition of the rising\_event output. When the rising event phase delay and dead-band time values are zero, the primary output starts immediately. Otherwise, the primary output is delayed. The rising event source causes all the following actions:

- Start rising event phase delay counter (if enabled).
- Clear complementary output after phase delay.
- Start falling event input blanking (if enabled).
- Start dead-band delay (if enabled).
- Set primary output after dead-band delay expires.

### 18.3.3 FALLING EVENT

The falling event terminates the PWM output active duty cycle period. The falling event is the high-to-low transition of the falling\_event output. When the falling event phase delay and dead-band time values are zero, the complementary output starts immediately. Otherwise, the complementary output is delayed. The falling event source causes all the following actions:

- Start falling event phase delay counter (if enabled).
- Clear primary output.
- Start rising event input blanking (if enabled).
- Start falling event dead-band delay (if enabled).
- Set complementary output after dead-band delay expires.

## 18.4 Output Control

Upon disabling, or immediately after enabling the COG module, the primary COG outputs are inactive and complementary COG outputs are active.

### 18.4.1 OUTPUT ENABLES

There are no output enable controls in the COG module. Instead, each device pin has an individual output selection control called the PPS register. All four COG outputs are available for selection in the PPS register of every pin.

When a COG output is enabled by PPS selection, the output on the pin has several possibilities, which depend on the steering control, GxEN bit, and shutdown state as shown in [Table 18-1](#).

**TABLE 18-1: PIN OUTPUT STATES**

GxEN	COGxSTR bit	Shutdown	Output
x	0	Inactive	Static steering data
x	1	Active	Shutdown override
0	1	Inactive	Inactive state
1	1	Inactive	Active PWM signal

### 18.4.2 POLARITY CONTROL

The polarity of each COG output can be selected independently. When the output polarity bit is set, the corresponding output is active low. Clearing the output polarity bit configures the corresponding output as active high. However, polarity affects the outputs in only one of the four shutdown override modes. See [Section 18.8, Auto-shutdown Control](#) for more details.

Output polarity is selected with the GxPOLA through GxPOLD bits of the COGxCON1 register ([Register 18-2](#)).

## 18.5 Dead-Band Control

The dead-band control provides for non-overlapping PWM output signals to prevent shoot-through current in the external power switches. Dead time affects the output only in the Half-Bridge mode and when changing direction in the Full-Bridge mode.

The COG contains two dead-band timers. One dead-band timer is used for rising event dead-band control. The other is used for falling event dead-band control. Timer modes are selectable as either:

- Asynchronous delay chain
- Synchronous counter

The dead-band Tmer mode is selected for the rising\_event and falling\_event dead-band times with the respective GxRDBS and GxFDBS bits of the COGxCON1 register ([Register 18-2](#)).

In Half-Bridge mode, the rising\_event dead-band time delays all selected primary outputs from going active for the selected dead time after the rising event. COGxA and COGxC are the primary outputs in Half-Bridge mode.

In Half-Bridge mode, the falling\_event dead-band time delays all selected complementary outputs from going active for the selected dead time after the falling event. COGxB and COGxD are the complementary outputs in Half-Bridge mode.

In Full-Bridge mode, the dead-time delay occurs only during direction changes. The modulated output is delayed for the falling\_event dead time after a direction change from forward to reverse. The modulated output is delayed for the rising\_event dead time after a direction change from reverse to forward.

### 18.5.1 ASYNCHRONOUS DELAY CHAIN DEAD-BAND DELAY

Asynchronous dead-band delay is determined by the time it takes the input to propagate through a series of delay elements. Each delay element is a nominal five nanoseconds.

Set the COGxDBR register ([Register 18-10](#)) value to the desired number of delay elements in the rising\_event dead-band time. Set the COGxDBF register ([Register 18-11](#)) value to the desired number of delay elements in the falling\_event dead-band time. When the value is zero, dead-band delay is disabled.

### 18.5.2 SYNCHRONOUS COUNTER DEAD-BAND DELAY

Synchronous counter dead band is timed by counting COG\_clock periods from zero up to the value in the dead-band count register. Use [Equation 18-1](#) to calculate dead-band times.

Set the COGxDBR count register value to obtain the desired rising\_event dead-band time. Set the COGxDBF count register value to obtain the desired falling\_event dead-band time. When the value is zero, dead-band delay is disabled.

### 18.5.3 SYNCHRONOUS COUNTER DEAD-BAND TIME UNCERTAINTY

When the rising and falling events that trigger the dead-band counters come from asynchronous inputs, it creates uncertainty in the synchronous counter dead-band time. The maximum uncertainty is equal to one COG\_clock period. Refer to [Example 18-1](#) for more detail.

When event input sources are asynchronous with no phase delay, use the asynchronous delay chain dead-band mode to avoid the dead-band time uncertainty.

# PIC16(L)F1717/8/9

---

## 18.5.4 RISING EVENT DEAD BAND

Rising event dead band delays the turn-on of the primary outputs from when complementary outputs are turned off. The rising event dead-band time starts when the rising\_event output goes true.

See [Section 18.5.1, Asynchronous Delay Chain Dead-Band Delay](#) and [Section 18.5.2, Synchronous Counter Dead-Band Delay](#) for more information on setting the rising edge dead-band time.

## 18.5.5 FALLING EVENT DEAD BAND

Falling event dead band delays the turn-on of complementary outputs from when the primary outputs are turned off. The falling event dead-band time starts when the falling\_event output goes true.

See [Section 18.5.1, Asynchronous Delay Chain Dead-Band Delay](#) and [Section 18.5.2, Synchronous Counter Dead-Band Delay](#) for more information on setting the rising edge dead-band time.

## 18.5.6 DEAD-BAND OVERLAP

There are two cases of dead-band overlap:

- Rising-to-falling
- Falling-to-rising

### 18.5.6.1 Rising-to-Falling Overlap

In this case, the falling event occurs while the rising event dead-band counter is still counting. When this happens, the primary drives are suppressed and the dead band extends by the falling event dead-band time. At the termination of the extended dead-band time, the complementary drive goes true.

### 18.5.6.2 Falling-to-Rising Overlap

In this case, the rising event occurs while the falling event dead-band counter is still counting. When this happens, the complementary drive is suppressed and the dead band extends by the rising event dead-band time. At the termination of the extended dead-band time, the primary drive goes true.

## 18.6 Blanking Control

Input blanking is a function, whereby, the event inputs can be masked or blanked for a short period of time. This is to prevent electrical transients caused by the turn-on/off of power components from generating a false input event.

The COG contains two blanking counters: one triggered by the rising event and the other triggered by the falling event. The counters are cross coupled with the events they are blanking. The falling event blanking counter is used to blank rising input events and the rising event blanking counter is used to blank falling input events. Once started, blanking extends for the time specified by the corresponding blanking counter.

Blanking is timed by counting COG\_clock periods from zero up to the value in the blanking count register. Use [Equation 18-1](#) to calculate blanking times.

## 18.6.1 FALLING EVENT BLANKING OF RISING EVENT INPUTS

The falling event blanking counter inhibits rising event inputs from triggering a rising event. The falling event blanking time starts when the rising event output drive goes false.

The falling event blanking time is set by the value contained in the COGxBLKF register ([Register 18-13](#)). Blanking times are calculated using the formula shown in [Equation 18-1](#).

When the COGxBLKF value is zero, falling event blanking is disabled and the blanking counter output is true, thereby, allowing the event signal to pass straight through to the event trigger circuit.

## 18.6.2 RISING EVENT BLANKING OF FALLING EVENT INPUTS

The rising event blanking counter inhibits falling event inputs from triggering a falling event. The rising event blanking time starts when the falling event output drive goes false.

The rising event blanking time is set by the value contained in the COGxBLKR register ([Register 18-12](#)).

When the COGxBLKR value is zero, rising event blanking is disabled and the blanking counter output is true, thereby, allowing the event signal to pass straight through to the event trigger circuit.

## 18.6.3 BLANKING TIME UNCERTAINTY

When the rising and falling sources that trigger the blanking counters are asynchronous to the COG\_clock, it creates uncertainty in the blanking time. The maximum uncertainty is equal to one COG\_clock period. Refer to [Equation 18-1](#) and [Example 18-1](#) for more detail.

## 18.7 Phase Delay

It is possible to delay the assertion of either or both the rising event and falling events. This is accomplished by placing a non-zero value in COGxPHR or COGxPHF phase-delay count register, respectively ([Register 18-14](#) and [Register 18-15](#)). Refer to [Figure 18-10](#) for COG operation with CCP1 and phase delay. The delay from the input rising event signal switching to the actual assertion of the events is calculated the same as the dead-band and blanking delays. Refer to [Equation 18-1](#).

When the phase-delay count value is zero, phase delay is disabled and the phase-delay counter output is true, thereby, allowing the event signal to pass straight through to the complementary output driver flop.

## 18.7.1 CUMULATIVE UNCERTAINTY

It is not possible to create more than one COG\_clock of uncertainty by successive stages. Consider that the phase-delay stage comes after the blanking stage, the dead-band stage comes after either the blanking or phase-delay stages, and the blanking stage comes after the dead-band stage. When the preceding stage is enabled, the output of that stage is necessarily synchronous with the COG\_clock, which removes any possibility of uncertainty in the succeeding stage.

### EQUATION 18-1: PHASE, DEAD-BAND, AND BLANKING TIME CALCULATION

$$T_{\min} = \frac{\text{Count}}{F_{\text{COG\_clock}}}$$

$$T_{\max} = \frac{\text{Count} + 1}{F_{\text{COG\_clock}}}$$

$$T_{\text{uncertainty}} = T_{\max} - T_{\min}$$

Also:

$$T_{\text{uncertainty}} = \frac{1}{F_{\text{COG\_clock}}}$$

Where:

T	Count
Rising Phase Delay	COGxPHR
Falling Phase Delay	COGxPHF
Rising Dead Band	COGxDBR
Falling Dead Band	COGxDBF
Rising Event Blanking	COGxBLKR
Falling Event Blanking	COGxBLKF

### EXAMPLE 18-1: TIMER UNCERTAINTY

Given:

$$\begin{aligned} \text{Count} &= Ah = 10d \\ F_{\text{COG\_Clock}} &= 8\text{MHz} \end{aligned}$$

Therefore:

$$\begin{aligned} T_{\text{uncertainty}} &= \frac{1}{F_{\text{COG\_clock}}} \\ &= \frac{1}{8\text{MHz}} = 125\text{ns} \end{aligned}$$

Proof:

$$\begin{aligned} T_{\min} &= \frac{\text{Count}}{F_{\text{COG\_clock}}} \\ &= 125\text{ns} \cdot 10d = 1.25\mu\text{s} \end{aligned}$$

$$\begin{aligned} T_{\max} &= \frac{\text{Count} + 1}{F_{\text{COG\_clock}}} \\ &= 125\text{ns} \cdot (10d + 1) \\ &= 1.375\mu\text{s} \end{aligned}$$

Therefore:

$$\begin{aligned} T_{\text{uncertainty}} &= T_{\max} - T_{\min} \\ &= 1.375\mu\text{s} - 1.25\mu\text{s} \\ &= 125\text{ns} \end{aligned}$$

# PIC16(L)F1717/8/9

## 18.8 Auto-shutdown Control

Auto-shutdown is a method to immediately override the COG output levels with specific overrides that allow for safe shutdown of the circuit.

The shutdown state can be either cleared automatically or held until cleared by software. In either case, the shutdown overrides remain in effect until the first rising event after the shutdown is cleared.

### 18.8.1 SHUTDOWN

The shutdown state can be entered by either of the following two mechanisms:

- Software generated
- External input

#### 18.8.1.1 Software Generated Shutdown

Setting the GxASE bit of the COGxASD0 register ([Register 18-7](#)) will force the COG into the shutdown state.

When auto-restart is disabled, the shutdown state will persist until the first rising event after the GxASE bit is cleared by software.

When auto-restart is enabled, the GxASE bit will clear automatically and resume operation on the first rising event after the shutdown input clears. See [Figure 18-15](#) and [Section 18.8.3.2 “Auto-Restart”](#).

#### 18.8.1.2 External Shutdown Source

External shutdown inputs provide the fastest way to safely suspend COG operation in the event of a Fault condition. When any of the selected shutdown inputs goes true, the output drive latches are reset and the COG outputs immediately go to the selected override levels without software delay.

Any combination of the input sources can be selected to cause a shutdown condition. Shutdown occurs when the selected source is low. Shutdown input sources include:

- Any input pin selected with the COGxPPS control
- C2OUT
- C1OUT
- CLC2OUT

Shutdown inputs are selected independently with bits of the COGxASD1 register ([Register 18-8](#)).

**Note:** Shutdown inputs are level sensitive, not edge sensitive. The shutdown state cannot be cleared as long as the shutdown input level persists, except by disabling auto-shutdown.

### 18.8.2 PIN OVERRIDE LEVELS

The levels driven to the output pins, while the shutdown is active, are controlled by the GxASDAC<1:0> and GxASDBC<1:0> bits of the COGxASD0 register ([Register 18-7](#)). GxASDAC<1:0> controls the COGxA and COGxC override levels and GxASDBC<1:0> controls the COGxB and COGxD override levels. There are four override options for each output pair:

- Forced low
- Forced high
- Tri-state
- PWM inactive state (same state as that caused by a falling event)

**Note:** The polarity control does not apply to the forced low and high override levels but does apply to the PWM inactive state.

### 18.8.3 AUTO-SHUTDOWN RESTART

After an auto-shutdown event has occurred, there are two ways to resume operation:

- Software controlled
- Auto-restart

The restart method is selected with the GxARSEN bit of the COGxASD0 register. Waveforms of a software controlled automatic restart are shown in [Figure 18-15](#).

#### 18.8.3.1 Software Controlled Restart

When the GxARSEN bit of the COGxASD0 register is cleared, software must clear the GxASE bit to restart COG operation after an auto-shutdown event.

The COG will resume operation on the first rising event after the GxASE bit is cleared. Clearing the shutdown state requires all selected shutdown inputs to be false, otherwise, the GxASE bit will remain set.

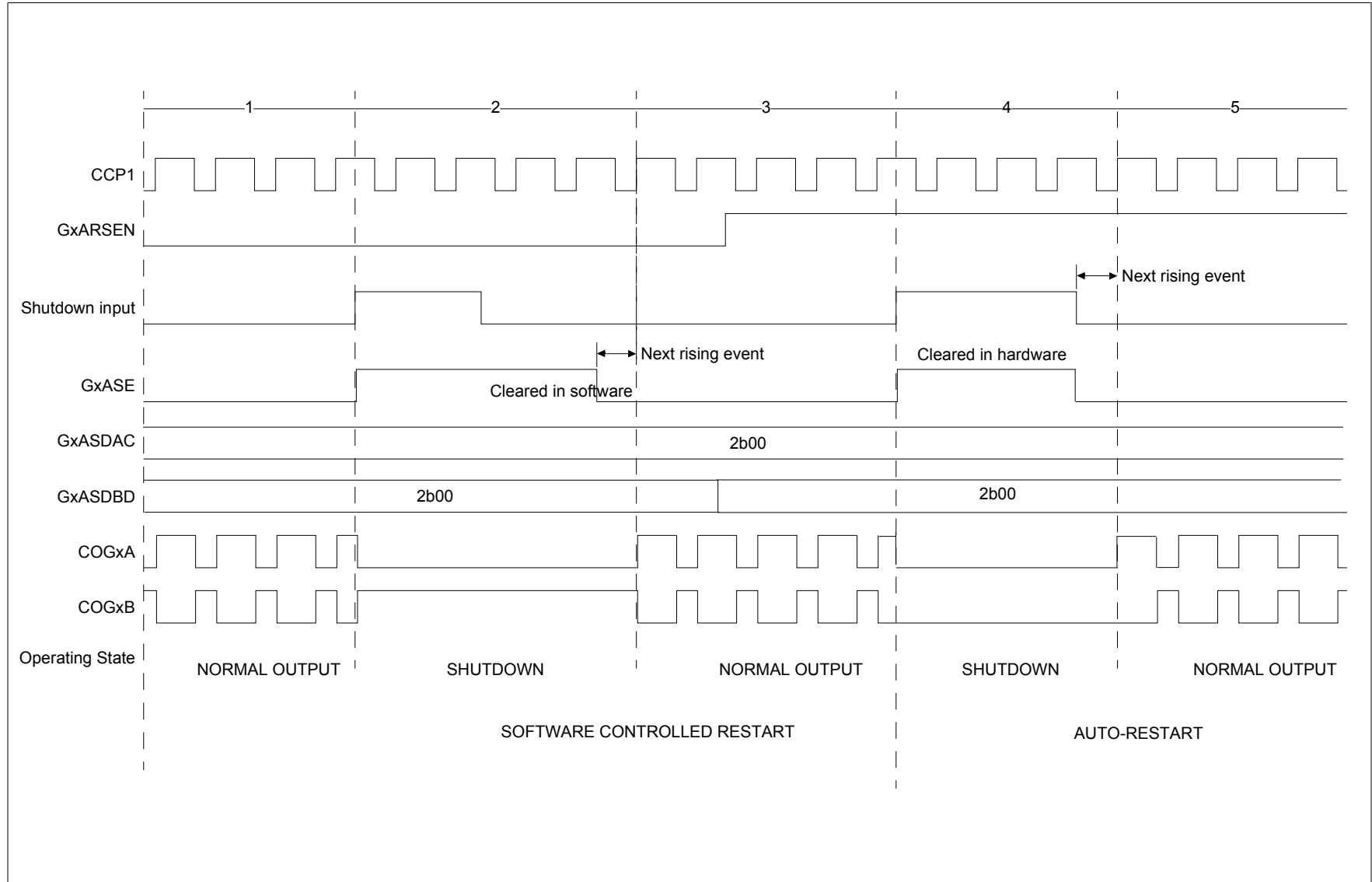
#### 18.8.3.2 Auto-Restart

When the GxARSEN bit of the COGxASD0 register is set, the COG will restart from the auto-shutdown state automatically.

The GxASE bit will clear automatically and the COG will resume operation on the first rising event after all selected shutdown inputs go false.



FIGURE 18-15: AUTO-SHUTDOWN WAVEFORM – CCP1 AS RISING AND FALLING EVENT INPUT SOURCE



## 18.9 Buffer Updates

Changes to the phase, dead band, and blanking count registers need to occur simultaneously during COG operation to avoid unintended operation that may occur as a result of delays between each register write. This is accomplished with the GxLD bit of the COGxCON0 register and double buffering of the phase, blanking, and dead-band count registers.

Before the COG module is enabled, writing the count registers loads the count buffers without need of the GxLD bit. However, when the COG is enabled, the count buffer updates are suspended after writing the count registers until after the GxLD bit is set. When the GxLD bit is set, the phase, dead-band, and blanking register values are transferred to the corresponding buffers synchronous with COG operation. The GxLD bit is cleared by hardware when the transfer is complete.

## 18.10 Input and Output Pin Selection

The COG has one selection for an input from a device pin. That one input can be used as rising and falling event source or a fault source. The COG1PPS register is used to select the pin. Refer to [Register 12-1](#) and [Register 12-2](#).

The pin PPS control registers are used to enable the COG outputs. Any combination of outputs to pins is possible including multiple pins for the same output. See the RxyPPS control register and [Section 12.2 “PPS Outputs”](#) for more details.

## 18.11 Operation During Sleep

The COG continues to operate in Sleep provided that the COG\_clock, rising event, and falling event sources remain active.

The HFINTSOC remains active during Sleep when the COG is enabled and the HFINTOSC is selected as the COG\_clock source.

## 18.12 Configuring the COG

The following steps illustrate how to properly configure the COG to ensure a synchronous start with the rising event input:

1. If a pin is to be used for the COG fault or event input, use the COGxPPS register to configure the desired pin.
2. Clear all ANSEL register bits associated with pins that are used for COG functions.
3. Ensure that the TRIS control bits corresponding to the COG outputs to be used are cleared so that all are configured as inputs. The COG module will disable the output drivers as needed for shutdown.
4. Clear the GxEN bit, if not already cleared.
5. Set desired dead-band times with the COGxDBR and COGxDBF registers and select the source with the COGxRDBS and COGxFDBS bits of the COGxCON1 register.
6. Set desired blanking times with the COGxBLKR and COGxBLKF registers.
7. Set desired phase delay with the COGxPHR and COGxPHF registers.
8. Select the desired shutdown sources with the COGxASD1 register.
9. Setup the following controls in COGxASD0 auto-shutdown register:
  - Select both output override controls to the desired levels (this is necessary, even if not using auto-shutdown because start-up will be from a shutdown state).
  - Set the GxASE bit and clear the GxARSEN bit.
10. Select the desired rising and falling event sources with the COGxRIS and COGxFIS registers.
11. Select the desired rising and falling event modes with the COGxRSIM and COGxFSIM registers.
12. Configure the following controls in the COGxCON1 register:
  - Select the desired clock source
  - Select the desired dead-band timing sources
13. Configure the following controls in the COGxSTR register:
  - Set the steering bits of the outputs to be used.
  - Set the static levels.
14. Set the polarity controls in the COGxCON1 register.
15. Set the GxEN bit.
16. Set the pin PPS controls to direct the COG outputs to the desired pins.
17. If auto-restart is to be used, set the GxARSEN bit and the GxASE will be cleared automatically. Otherwise, clear the GxASE bit to start the COG.

## 18.13 Register Definitions: COG Control

### REGISTER 18-1: COGxCON0: COG CONTROL REGISTER 0

R/W-0/0	R/W-0/0	U-0	R/W-0/0	R/W-0/0	R/W-0/0	R/W-0/0	R/W-0/0
GxEN	GxLD	—	GxCS<1:0>		GxMD<2:0>		
bit 7							bit 0

#### Legend:

R = Readable bit	W = Writable bit	U = Unimplemented bit, read as '0'
u = Bit is unchanged	x = Bit is unknown	-n/n = Value at POR and BOR/Value at all other Resets
'1' = Bit is set	'0' = Bit is cleared	q = Value depends on condition

bit 7	<b>GxEN:</b> COGx Enable bit 1 = Module is enabled 0 = Module is disabled
bit 6	<b>GxLD:</b> COGx Load Buffers bit 1 = Phase, blanking, and dead-band buffers to be loaded with register values on next input events 0 = Register to buffer transfer is complete
bit 5	<b>Unimplemented:</b> Read as '0'
bit 4-3	<b>GxCS&lt;1:0&gt;:</b> COGx Clock Selection bits 11 = Reserved. Do not use. 10 = COG_clock is HFINTOSC (stays active during Sleep) 01 = COG_clock is Fosc 00 = COG_clock is Fosc/4
bit 2-0	<b>GxMD&lt;2:0&gt;:</b> COGx Mode Selection bits 11x = Reserved. Do not use. 101 = COG outputs operate in Push-Pull mode 100 = COG outputs operate in Half-Bridge mode 011 = COG outputs operate in Reverse Full-Bridge mode 010 = COG outputs operate in Forward Full-Bridge mode 001 = COG outputs operate in synchronous steered PWM mode 000 = COG outputs operate in steered PWM mode

# PIC16(L)F1717/8/9

## REGISTER 18-2: COGxCON1: COG CONTROL REGISTER 1

R/W-0/0	R/W-0/0	U-0	U-0	R/W-0/0	R/W-0/0	R/W-0/0	R/W-0/0
GxRDBS	GxFDBS	—	—	GxPOLD	GxPOLC	GxPOLB	GxPOLA
bit 7							bit 0

### Legend:

R = Readable bit	W = Writable bit	U = Unimplemented bit, read as '0'
u = Bit is unchanged	x = Bit is unknown	-n/n = Value at POR and BOR/Value at all other Resets
'1' = Bit is set	'0' = Bit is cleared	q = Value depends on condition

- bit 7      **GxRDBS:** COGx Rising Event Dead-band Timing Source Select bit  
1 = Delay chain and COGxDBR are used for dead-band timing generation  
0 = COGx\_clock and COGxDBR are used for dead-band timing generation
- bit 6      **GxFDBS:** COGx Falling Event Dead-band Timing Source select bit  
1 = Delay chain and COGxDF are used for dead-band timing generation  
0 = COGx\_clock and COGxDBF are used for dead-band timing generation
- bit 5-4    **Unimplemented:** Read as '0'.
- bit 3      **GxPOLD:** COGxD Output Polarity Control bit  
1 = Active level of COGxD output is low  
0 = Active level of COGxD output is high
- bit 2      **GxPOLC:** COGxC Output Polarity Control bit  
1 = Active level of COGxC output is low  
0 = Active level of COGxC output is high
- bit 1      **GxPOLB:** COGxB Output Polarity Control bit  
1 = Active level of COGxB output is low  
0 = Active level of COGxB output is high
- bit 0      **GxPOLA:** COGxA Output Polarity Control bit  
1 = Active level of COGxA output is low  
0 = Active level of COGxA output is high

## REGISTER 18-3: COGxRIS: COG RISING EVENT INPUT SELECTION REGISTER

R/W-0/0	R/W-0/0	R/W-0/0	R/W-0/0	R/W-0/0	R/W-0/0	R/W-0/0	R/W-0/0
GxRIS7	GxRIS6	GxRIS5	GxRIS4	GxRIS3	GxRIS2	GxRIS1	GxRIS0
bit 7							bit 0

### Legend:

R = Readable bit	W = Writable bit	U = Unimplemented bit, read as '0'
u = Bit is unchanged	x = Bit is unknown	-n/n = Value at POR and BOR/Value at all other Resets
'1' = Bit is set	'0' = Bit is cleared	q = Value depends on condition

- bit 7      **GxRIS7:** COGx Rising Event Input Source 7 Enable bit  
1 = NCO1\_out is enabled as a rising event input  
0 = NCO1\_out has no effect on the rising event
- bit 6      **GxRIS6:** COGx Rising Event Input Source 6 Enable bit  
1 = PWM3 output is enabled as a rising event input  
0 = PWM3 has no effect on the rising event
- bit 5      **GxRIS5:** COGx Rising Event Input Source 5 Enable bit  
1 = CCP2 output is enabled as a rising event input  
0 = CCP2 output has no effect on the rising event
- bit 4      **GxRIS4:** COGx Rising Event Input Source 4 Enable bit  
1 = CCP1 is enabled as a rising event input  
0 = CCP1 has no effect on the rising event
- bit 3      **GxRIS3:** COGx Rising Event Input Source 3 Enable bit  
1 = CLC1 output is enabled as a rising event input  
0 = CLC1 output has no effect on the rising event
- bit 2      **GxRIS2:** COGx Rising Event Input Source 2 Enable bit  
1 = Comparator 2 output is enabled as a rising event input  
0 = Comparator 2 output has no effect on the rising event
- bit 1      **GxRIS1:** COGx Rising Event Input Source 1 Enable bit  
1 = Comparator 1 output is enabled as a rising event input  
0 = Comparator 1 output has no effect on the rising event
- bit 0      **GxRIS0:** COGx Rising Event Input Source 0 Enable bit  
1 = Pin selected with COGxPPS control register is enabled as rising event input  
0 = Pin selected with COGxPPS control has no effect on the rising event

# PIC16(L)F1717/8/9

## REGISTER 18-4: COGxRSIM: COG RISING EVENT SOURCE INPUT MODE REGISTER

R/W-0/0	R/W-0/0	R/W-0/0	R/W-0/0	R/W-0/0	R/W-0/0	R/W-0/0	R/W-0/0
GxRSIM7	GxRSIM6	GxRSIM5	GxRSIM4	GxRSIM3	GxRSIM2	GxRSIM1	GxRSIM0
bit 7							bit 0

### Legend:

R = Readable bit	W = Writable bit	U = Unimplemented bit, read as '0'
u = Bit is unchanged	x = Bit is unknown	-n/n = Value at POR and BOR/Value at all other Resets
'1' = Bit is set	'0' = Bit is cleared	q = Value depends on condition

- bit 7      **GxRSIM7:** COGx Rising Event Input Source 7 Mode bit  
GxRIS7 = 1:  
 1 = NCO1\_out low-to-high transition will cause a rising event after rising event phase delay  
 0 = NCO1\_out high level will cause an immediate rising event  
GxRIS7 = 0:  
 NCO1\_out has no effect on rising event
- bit 6      **GxRSIM6:** COGx Rising Event Input Source 6 Mode bit  
GxRIS6 = 1:  
 1 = PWM3 output low-to-high transition will cause a rising event after rising event phase delay  
 0 = PWM3 output high level will cause an immediate rising event  
GxRIS6 = 0:  
 PWM3 output has no effect on rising event
- bit 5      **GxRSIM5:** COGx Rising Event Input Source 5 Mode bit  
GxRIS5 = 1:  
 1 = CCP2 output low-to-high transition will cause a rising event after rising event phase delay  
 0 = CCP2 output high level will cause an immediate rising event  
GxRIS5 = 0:  
 CCP2 output has no effect on rising event
- bit 4      **GxRSIM4:** COGx Rising Event Input Source 4 Mode bit  
GxRIS4 = 1:  
 1 = CCP1 low-to-high transition will cause a rising event after rising event phase delay  
 0 = CCP1 high level will cause an immediate rising event  
GxRIS4 = 0:  
 CCP1 has no effect on rising event
- bit 3      **GxRSIM3:** COGx Rising Event Input Source 3 Mode bit  
GxRIS3 = 1:  
 1 = CLC1 output low-to-high transition will cause a rising event after rising event phase delay  
 0 = CLC1 output high level will cause an immediate rising event  
GxRIS3 = 0:  
 CLC1 output has no effect on rising event
- bit 2      **GxRSIM2:** COGx Rising Event Input Source 2 Mode bit  
GxRIS2 = 1:  
 1 = Comparator 2 low-to-high transition will cause a rising event after rising event phase delay  
 0 = Comparator 2 high level will cause an immediate rising event  
GxRIS2 = 0:  
 Comparator 2 has no effect on rising event
- bit 1      **GxRSIM1:** COGx Rising Event Input Source 1 Mode bit  
GxRIS1 = 1:  
 1 = Comparator 1 low-to-high transition will cause a rising event after rising event phase delay  
 0 = Comparator 1 high level will cause an immediate rising event  
GxRIS1 = 0:  
 Comparator 1 has no effect on rising event

## REGISTER 18-4: COGxRSIM: COG RISING EVENT SOURCE INPUT MODE REGISTER

bit 0

**GxRSIM0:** COGx Rising Event Input Source 0 Mode bit

GxRIS0 = 1:

1 = Pin selected with COGxPPS control low-to-high transition will cause a rising event after rising event phase delay

0 = Pin selected with COGxPPS control high level will cause an immediate rising event

GxRIS0 = 0:

Pin selected with COGxPPS control has no effect on rising event

# PIC16(L)F1717/8/9

## REGISTER 18-5: COGxFIS: COG FALLING EVENT INPUT SELECTION REGISTER

R/W-0/0	R/W-0/0	R/W-0/0	R/W-0/0	R/W-0/0	R/W-0/0	R/W-0/0	R/W-0/0
GxFIS7	GxFIS6	GxFIS5	GxFIS4	GxFIS3	GxFIS2	GxFIS1	GxFIS0
bit 7							bit 0

### Legend:

R = Readable bit	W = Writable bit	U = Unimplemented bit, read as '0'
u = Bit is unchanged	x = Bit is unknown	-n/n = Value at POR and BOR/Value at all other Resets
'1' = Bit is set	'0' = Bit is cleared	q = Value depends on condition

- bit 7      **GxFIS7:** COGx Falling Event Input Source 7 Enable bit  
1 = NCO1\_out is enabled as a falling event input  
0 = NCO1\_out has no effect on the falling event
- bit 6      **GxFIS6:** COGx Falling Event Input Source 6 Enable bit  
1 = PWM3 output is enabled as a falling event input  
0 = PWM3 has no effect on the falling event
- bit 5      **GxFIS5:** COGx Falling Event Input Source 5 Enable bit  
1 = CCP2 output is enabled as a falling event input  
0 = CCP2 output has no effect on the falling event
- bit 4      **GxFIS4:** COGx Falling Event Input Source 4 Enable bit  
1 = CCP1 is enabled as a falling event input  
0 = CCP1 has no effect on the falling event
- bit 3      **GxFIS3:** COGx Falling Event Input Source 3 Enable bit  
1 = CLC1 output is enabled as a falling event input  
0 = CLC1 output has no effect on the falling event
- bit 2      **GxFIS2:** COGx Falling Event Input Source 2 Enable bit  
1 = Comparator 2 output is enabled as a falling event input  
0 = Comparator 2 output has no effect on the falling event
- bit 1      **GxFIS1:** COGx Falling Event Input Source 1 Enable bit  
1 = Comparator 1 output is enabled as a falling event input  
0 = Comparator 1 output has no effect on the falling event
- bit 0      **GxFIS0:** COGx Falling Event Input Source 0 Enable bit  
1 = Pin selected with COGxPPS control register is enabled as falling event input  
0 = Pin selected with COGxPPS control has no effect on the falling event



## REGISTER 18-6: COGxFSIM: COG FALLING EVENT SOURCE INPUT MODE REGISTER

R/W-0/0	R/W-0/0	R/W-0/0	R/W-0/0	R/W-0/0	R/W-0/0	R/W-0/0	R/W-0/0
GxFSIM7	GxFSIM6	GxFSIM5	GxFSIM4	GxFSIM3	GxFSIM2	GxFSIM1	GxFSIM0
bit 7							bit 0

### Legend:

R = Readable bit	W = Writable bit	U = Unimplemented bit, read as '0'
u = Bit is unchanged	x = Bit is unknown	-n/n = Value at POR and BOR/Value at all other Resets
'1' = Bit is set	'0' = Bit is cleared	q = Value depends on condition

bit 7	<p><b>GxFSIM7:</b> COGx Falling Event Input Source 7 Mode bit</p> <p><u>GxFIS7 = 1:</u> 1 = NCO1_out high-to-low transition will cause a falling event after falling event phase delay 0 = NCO1_out low level will cause an immediate falling event</p> <p><u>GxFIS7 = 0:</u> NCO1_out has no effect on falling event</p>
bit 6	<p><b>GxFSIM6:</b> COGx Falling Event Input Source 6 Mode bit</p> <p><u>GxFIS6 = 1:</u> 1 = PWM3 output high-to-low transition will cause a falling event after falling event phase delay 0 = PWM3 output low level will cause an immediate falling event</p> <p><u>GxFIS6 = 0:</u> PWM3 output has no effect on falling event</p>
bit 5	<p><b>GxFSIM5:</b> COGx Falling Event Input Source 5 Mode bit</p> <p><u>GxFIS5 = 1:</u> 1 = CCP2 output high-to-low transition will cause a falling event after falling event phase delay 0 = CCP2 output low level will cause an immediate falling event</p> <p><u>GxFIS5 = 0:</u> CCP2 output has no effect on falling event</p>
bit 4	<p><b>GxFSIM4:</b> COGx Falling Event Input Source 4 Mode bit</p> <p><u>GxFIS4 = 1:</u> 1 = CCP1 high-to-low transition will cause a falling event after falling event phase delay 0 = CCP1 low level will cause an immediate falling event</p> <p><u>GxFIS4 = 0:</u> CCP1 has no effect on falling event</p>
bit 3	<p><b>GxFSIM3:</b> COGx Falling Event Input Source 3 Mode bit</p> <p><u>GxFIS3 = 1:</u> 1 = CLC1 output high-to-low transition will cause a falling event after falling event phase delay 0 = CLC1 output low level will cause an immediate falling event</p> <p><u>GxFIS3 = 0:</u> CLC1 output has no effect on falling event</p>
bit 2	<p><b>GxFSIM2:</b> COGx Falling Event Input Source 2 Mode bit</p> <p><u>GxFIS2 = 1:</u> 1 = Comparator 2 high-to-low transition will cause a falling event after falling event phase delay 0 = Comparator 2 low level will cause an immediate falling event</p> <p><u>GxFIS2 = 0:</u> Comparator 2 has no effect on falling event</p>
bit 1	<p><b>GxFSIM1:</b> COGx Falling Event Input Source 1 Mode bit</p> <p><u>GxFIS1 = 1:</u> 1 = Comparator 1 high-to-low transition will cause a falling event after falling event phase delay 0 = Comparator 1 low level will cause an immediate falling event</p> <p><u>GxFIS1 = 0:</u> Comparator 1 has no effect on falling event</p>

# PIC16(L)F1717/8/9

---

## REGISTER 18-6: COGxFSIM: COG FALLING EVENT SOURCE INPUT MODE REGISTER

bit 0

**GxFSIM0:** COGx Falling Event Input Source 0 Mode bit

GxFIS0 = 1:

1 = Pin selected with COGxPPS control high-to-low transition will cause a falling event after falling event phase delay

0 = Pin selected with COGxPPS control low level will cause an immediate falling event

GxFIS0 = 0:

Pin selected with COGxPPS control has no effect on falling event

## REGISTER 18-7: COGxASD0: COG AUTO-SHUTDOWN CONTROL REGISTER 0

R/W-0/0	R/W-0/0	R/W-0/0	R/W-0/0	R/W-0/0	R/W-0/0	U-0	U-0
GxASE	GxARSEN	GxASDBD<1:0>		GxASDAC<1:0>		—	—
bit 7						bit 0	

### Legend:

R = Readable bit	W = Writable bit	U = Unimplemented bit, read as '0'
u = Bit is unchanged	x = Bit is unknown	-n/n = Value at POR and BOR/Value at all other Resets
'1' = Bit is set	'0' = Bit is cleared	q = Value depends on condition

- bit 7      **GxASE:** Auto-Shutdown Event Status bit  
1 = COG is in the shutdown state  
0 = COG is either not in the shutdown state or will exit the shutdown state on the next rising event
- bit 6      **GxARSEN:** Auto-Restart Enable bit  
1 = Auto-restart is enabled  
0 = Auto-restart is disabled
- bit 5-4    **GxASDBD<1:0>:** COGxB and COGxD Auto-shutdown Override Level Select bits  
11 = A logic '1' is placed on COGxB and COGxD when shutdown is active  
10 = A logic '0' is placed on COGxB and COGxD when shutdown is active  
01 = COGxB and COGxD are tri-stated when shutdown is active  
00 = The inactive state of the pin, including polarity, is placed on COGxB and COGxD when shutdown is active
- bit 3-2    **GxASDAC<1:0>:** COGxA and COGxC Auto-shutdown Override Level Select bits  
11 = A logic '1' is placed on COGxA and COGxC when shutdown is active  
10 = A logic '0' is placed on COGxA and COGxC when shutdown is active  
01 = COGxA and COGxC are tri-stated when shutdown is active  
00 = The inactive state of the pin, including polarity, is placed on COGxA and COGxC when shutdown is active
- bit 1-0    **Unimplemented:** Read as '0'

# PIC16(L)F1717/8/9

## REGISTER 18-8: COGxASD1: COG AUTO-SHUTDOWN CONTROL REGISTER 1

U-0	U-0	U-0	U-0	R/W-0/0	R/W-0/0	R/W-0/0	R/W-0/0
—	—	—	—	GxAS3E	GxAS2E	GxAS1E	GxAS0E
bit 7							bit 0

### Legend:

R = Readable bit

W = Writable bit

U = Unimplemented bit, read as '0'

u = Bit is unchanged

x = Bit is unknown

-n/n = Value at POR and BOR/Value at all other Resets

'1' = Bit is set

'0' = Bit is cleared

q = Value depends on condition

bit 7-4 **Unimplemented:** Read as '0'

bit 3 **GxAS3E:** COGx Auto-shutdown Source Enable bit 3

1 = COGx is shutdown when CLC2 output is low

0 = CLC2 output has no effect on shutdown

bit 2 **GxAS2E:** COGx Auto-shutdown Source Enable bit 2

1 = COGx is shutdown when Comparator 2 output is low

0 = Comparator 2 output has no effect on shutdown

bit 1 **GxAS1E:** COGx Auto-shutdown Source Enable bit 1

1 = COGx is shutdown when Comparator 1 output is low

0 = Comparator 1 output has no effect on shutdown

bit 0 **GxAS0E:** COGx Auto-shutdown Source Enable bit 0

1 = COGx is shutdown when Pin selected with COGxPPS control is low

0 = Pin selected with COGxPPS control has no effect on shutdown

## REGISTER 18-9: COG<sub>x</sub>STR: COG STEERING CONTROL REGISTER 1

R/W-0/0	R/W-0/0	R/W-0/0	R/W-0/0	R/W-0/0	R/W-0/0	R/W-0/0	R/W-0/0
GxDATD	GxDATC	GxDATB	GxDATA	GxSTRD	GxSTRC	GxSTRB	GxSTRA
bit 7							bit 0

### Legend:

R = Readable bit	W = Writable bit	U = Unimplemented bit, read as '0'
u = Bit is unchanged	x = Bit is unknown	-n/n = Value at POR and BOR/Value at all other Resets
'1' = Bit is set	'0' = Bit is cleared	q = Value depends on condition

bit 7	<b>GxSDATD:</b> COG <sub>x</sub> D Static Output Data bit 1 = COG <sub>x</sub> D static data is high 0 = COG <sub>x</sub> D static data is low
bit 6	<b>GxSDATC:</b> COG <sub>x</sub> C Static Output Data bit 1 = COG <sub>x</sub> C static data is high 0 = COG <sub>x</sub> C static data is low
bit 5	<b>GxSDATB:</b> COG <sub>x</sub> B Static Output Data bit 1 = COG <sub>x</sub> B static data is high 0 = COG <sub>x</sub> B static data is low
bit 4	<b>GxSDATA:</b> COG <sub>x</sub> A Static Output Data bit 1 = COG <sub>x</sub> A static data is high 0 = COG <sub>x</sub> A static data is low
bit 3	<b>GxSTRD:</b> COG <sub>x</sub> D Steering Control bit 1 = COG <sub>x</sub> D output has the COG <sub>x</sub> D waveform with polarity control from GxPOLD bit 0 = COG <sub>x</sub> D output is the static data level determined by the GxSDATD bit
bit 2	<b>GxSTRC:</b> COG <sub>x</sub> C Steering Control bit 1 = COG <sub>x</sub> C output has the COG <sub>x</sub> C waveform with polarity control from GxPOLC bit 0 = COG <sub>x</sub> C output is the static data level determined by the GxSDATC bit
bit 1	<b>GxSTRB:</b> COG <sub>x</sub> B Steering Control bit 1 = COG <sub>x</sub> B output has the COG <sub>x</sub> B waveform with polarity control from GxPOLB bit 0 = COG <sub>x</sub> B output is the static data level determined by the GxSDATB bit
bit 0	<b>GxSTRA:</b> COG <sub>x</sub> A Steering Control bit 1 = COG <sub>x</sub> A output has the COG <sub>x</sub> A waveform with polarity control from GxPOLA bit 0 = COG <sub>x</sub> A output is the static data level determined by the GxSDATA bit

# PIC16(L)F1717/8/9

## REGISTER 18-10: COGxDBR: COG RISING EVENT DEAD-BAND COUNT REGISTER

U-0	U-0	R/W-x/u	R/W-x/u	R/W-x/u	R/W-x/u	R/W-x/u	R/W-x/u
—	—	GxDBR<5:0>					
bit 7							bit 0

### Legend:

R = Readable bit                      W = Writable bit                      U = Unimplemented bit, read as '0'  
u = Bit is unchanged                      x = Bit is unknown                      -n/n = Value at POR and BOR/Value at all other Resets  
'1' = Bit is set                              '0' = Bit is cleared                      q = Value depends on condition

bit 7-6                      **Unimplemented:** Read as '0'

bit 5-0                      **GxDBR<5:0>:** Rising Event Dead-band Count Value bits

GxRDBS = 1:

= Number of delay chain element periods to delay primary output after rising event

GxRDBS = 0:

= Number of COGx clock periods to delay primary output after rising event

## REGISTER 18-11: COGxDBF: COG FALLING EVENT DEAD-BAND COUNT REGISTER

U-0	U-0	R/W-x/u	R/W-x/u	R/W-x/u	R/W-x/u	R/W-x/u	R/W-x/u
—	—	GxDBF<5:0>					
bit 7							bit 0

### Legend:

R = Readable bit                      W = Writable bit                      U = Unimplemented bit, read as '0'  
u = Bit is unchanged                      x = Bit is unknown                      -n/n = Value at POR and BOR/Value at all other Resets  
'1' = Bit is set                              '0' = Bit is cleared                      q = Value depends on condition

bit 7-6                      **Unimplemented:** Read as '0'

bit 5-0                      **GxDBF<5:0>:** Falling Event Dead-band Count Value bits

GxFDBS = 1:

= Number of delay chain element periods to delay complementary output after falling event input

GxFDBS = 0:

= Number of COGx clock periods to delay complementary output after falling event input

## REGISTER 18-12: COGxBLKR: COG RISING EVENT BLANKING COUNT REGISTER

U-0	U-0	R/W-x/u	R/W-x/u	R/W-x/u	R/W-x/u	R/W-x/u	R/W-x/u
—	—	GxBLKR<5:0>					
bit 7							bit 0

### Legend:

R = Readable bit	W = Writable bit	U = Unimplemented bit, read as '0'
u = Bit is unchanged	x = Bit is unknown	-n/n = Value at POR and BOR/Value at all other Resets
'1' = Bit is set	'0' = Bit is cleared	q = Value depends on condition

bit 7-6      **Unimplemented:** Read as '0'  
bit 5-0      **GxBLKR<5:0>:** Rising Event Blanking Count Value bits  
= Number of COGx clock periods to inhibit falling event inputs

## REGISTER 18-13: COGxBLKF: COG FALLING EVENT BLANKING COUNT REGISTER

U-0	U-0	R/W-x/u	R/W-x/u	R/W-x/u	R/W-x/u	R/W-x/u	R/W-x/u
—	—	GxBLKF<5:0>					
bit 7							bit 0

### Legend:

R = Readable bit	W = Writable bit	U = Unimplemented bit, read as '0'
u = Bit is unchanged	x = Bit is unknown	-n/n = Value at POR and BOR/Value at all other Resets
'1' = Bit is set	'0' = Bit is cleared	q = Value depends on condition

bit 7-6      **Unimplemented:** Read as '0'  
bit 5-0      **GxBLKF<5:0>:** Falling Event Blanking Count Value bits  
= Number of COGx clock periods to inhibit rising event inputs

# PIC16(L)F1717/8/9

## REGISTER 18-14: COGxPHR: COG RISING EDGE PHASE DELAY COUNT REGISTER

U-0	U-0	R/W-x/u	R/W-x/u	R/W-x/u	R/W-x/u	R/W-x/u	R/W-x/u
—	—	GxPHR<5:0>					
bit 7							bit 0

### Legend:

R = Readable bit	W = Writable bit	U = Unimplemented bit, read as '0'
u = Bit is unchanged	x = Bit is unknown	-n/n = Value at POR and BOR/Value at all other Resets
'1' = Bit is set	'0' = Bit is cleared	q = Value depends on condition

bit 7-6      **Unimplemented:** Read as '0'

bit 5-0      **GxPHR<5:0>:** Rising Edge Phase Delay Count Value bits  
 = Number of COGx clock periods to delay rising edge event

## REGISTER 18-15: COGxPHF: COG FALLING EDGE PHASE DELAY COUNT REGISTER

U-0	U-0	R/W-x/u	R/W-x/u	R/W-x/u	R/W-x/u	R/W-x/u	R/W-x/u
—	—	GxPHF<5:0>					
bit 7							bit 0

### Legend:

R = Readable bit	W = Writable bit	U = Unimplemented bit, read as '0'
u = Bit is unchanged	x = Bit is unknown	-n/n = Value at POR and BOR/Value at all other Resets
'1' = Bit is set	'0' = Bit is cleared	q = Value depends on condition

bit 7-6      **Unimplemented:** Read as '0'

bit 5-0      **GxPHF<5:0>:** Falling Edge Phase Delay Count Value bits  
 = Number of COGx clock periods to delay falling edge event



**TABLE 18-2: SUMMARY OF REGISTERS ASSOCIATED WITH COG**

Name	Bit 7	Bit 6	Bit 5	Bit 4	Bit 3	Bit 2	Bit 1	Bit 0	Register on Page	
ANSELA	—	—	ANSA5	ANSA4	ANSA3	ANSA2	ANSA1	ANSA0	125	
ANSELB	—	—	ANSB5	ANSB4	ANSB3	ANSB2	ANSB1	ANSB0	131	
ANSELC	ANSC7	ANSC6	ANSC5	ANSC4	ANSC3	ANSC2	—	—	136	
COG1PHR	—	—	G1PHR<5:0>						216	
COG1PHF	—	—	G1PHF<5:0>						216	
COG1BLKR	—	—	G1BLKR<5:0>						215	
COG1BLKF	—	—	G1BLKF<5:0>						215	
COG1DBR	—	—	G1DBR<5:0>						214	
COG1DBF	—	—	G1DBF<5:0>						214	
COG1RIS	G1RIS7	G1RIS6	G1RIS5	G1RIS4	G1RIS3	G1RIS2	G1RIS1	G1RIS0	205	
COG1RSIM	G1RSIM7	G1RSIM6	G1RSIM5	G1RSIM4	G1RSIM3	G1RSIM2	G1RSIM1	G1RSIM0	206	
COG1FIS	G1FIS7	G1FIS6	G1FIS5	G1FIS4	G1FIS3	G1FIS2	G1FIS1	G1FIS0	208	
COG1FSIM	G1FSIM7	G1FSIM6	G1FSIM5	G1FSIM4	G1FSIM3	G1FSIM2	G1FSIM1	G1FSIM0	209	
COG1CON0	G1EN	G1LD	—	G1CS<1:0>			G1MD<2:0>		203	
COG1CON1	G1RDBS	G1FDBS	—	—	G1POLD	G1POLC	G1POLB	G1POLA	204	
COG1ASD0	G1ASE	G1ARSEN	G1ASDBD<1:0>		G1ASDAC<1:0>		—	—	211	
COG1ASD1	—	—	—	—	G1AS3E	G1AS2E	G1AS1E	G1AS0E	212	
COG1STR	G1SDATD	G1SDATC	G1SDATB	G1SDATA	G1STRD	G1STRC	G1STRB	G1STRA	213	
INTCON	GIE	PEIE	T0IE	INTE	IOIE	T0IF	INTF	IOCIF	90	
COG1PPS	—	—	—	COG1PPS<4:0>						136
PIE2	OSFIE	C2IE	C1IE	—	BCL1IE	TMR6IE	TMR4IE	CCP2IE	92	
PIR2	OSFIF	C2IF	C1IF	—	BCL1IF	TMR6IF	TMR4IF	CCP2IF	95	
RxyPPS	—	—	—	RxyPPS<4:0>						153

**Legend:** x = unknown, u = unchanged, — = unimplemented locations read as '0'. Shaded cells are not used by COG.

# PIC16(L)F1717/8/9

## 19.0 CONFIGURABLE LOGIC CELL (CLC)

The Configurable Logic Cell (CLCx) provides programmable logic that operates outside the speed limitations of software execution. The logic cell takes up to 32 input signals and, through the use of configurable gates, reduces the 32 inputs to four logic lines that drive one of eight selectable single-output logic functions.

Input sources are a combination of the following:

- I/O pins
- Internal clocks
- Peripherals
- Register bits

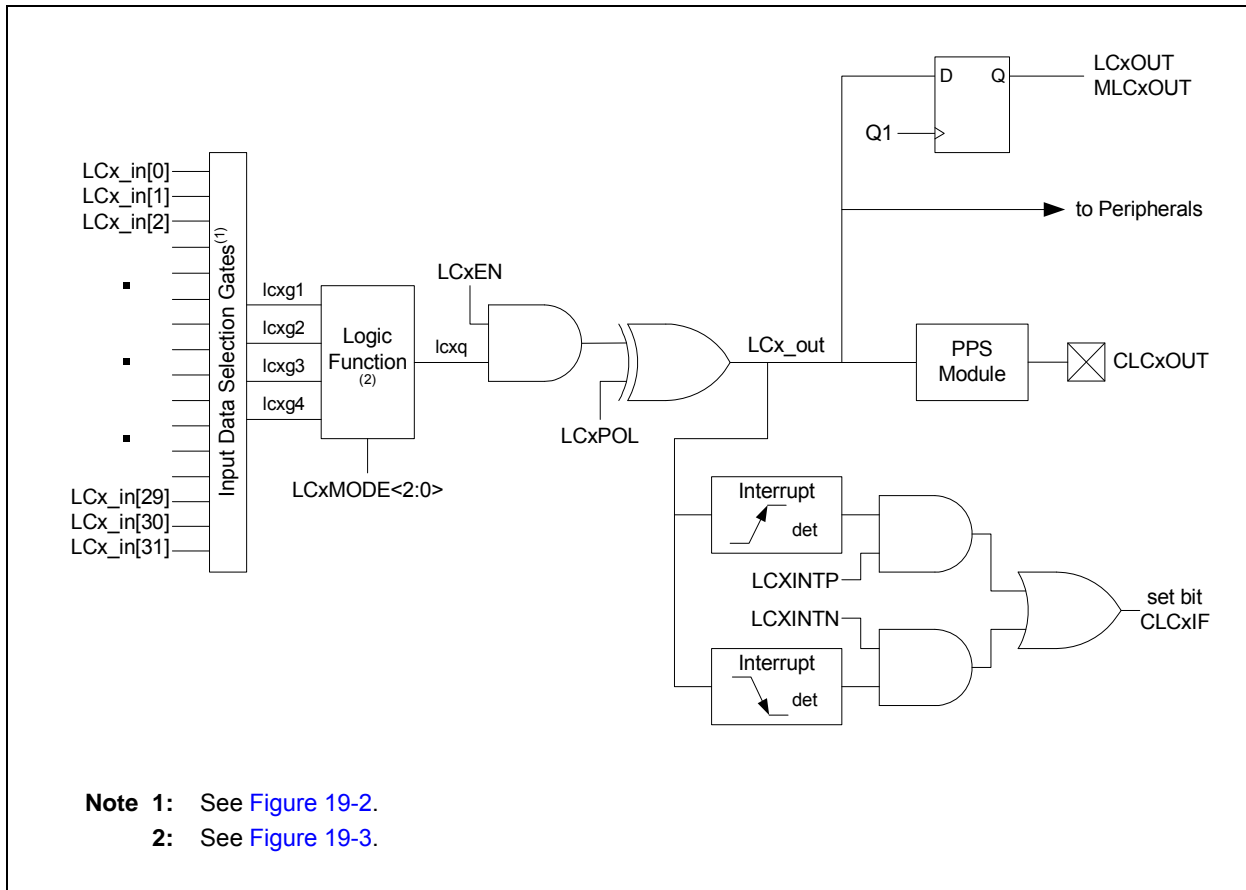
The output can be directed internally to peripherals and to an output pin.

Refer to [Figure 19-1](#) for a simplified diagram showing signal flow through the CLCx.

Possible configurations include:

- Combinatorial Logic
  - AND
  - NAND
  - AND-OR
  - AND-OR-INVERT
  - OR-XOR
  - OR-XNOR
- Latches
  - S-R
  - Clocked D with Set and Reset
  - Transparent D with Set and Reset
  - Clocked J-K with Reset

**FIGURE 19-1: CLCx SIMPLIFIED BLOCK DIAGRAM**



## 19.1 CLCx Setup

Programming the CLCx module is performed by configuring the four stages in the logic signal flow. The four stages are:

- Data selection
- Data gating
- Logic function selection
- Output polarity

Each stage is setup at run time by writing to the corresponding CLCx Special Function Registers. This has the added advantage of permitting logic reconfiguration on-the-fly during program execution.

### 19.1.1 DATA SELECTION

There are 32 signals available as inputs to the configurable logic. Four 32-input multiplexers are used to select the inputs to pass on to the next stage.

Data selection is through four multiplexers as indicated on the left side of [Figure 19-2](#). Data inputs in the figure are identified by a generic numbered input name.

[Table 19-1](#) correlates the generic input name to the actual signal for each CLC module. The column labeled *lcxdy* indicates the MUX selection code for the selected data input. *DxS* is an abbreviation for the MUX select input codes: LCxD1S<4:0> through LCxD4S<4:0>.

Data inputs are selected with CLCxSEL0 through CLCxSEL3 registers ([Register 19-3](#) through [Register 19-6](#)).

**Note:** Data selections are undefined at power-up.

**TABLE 19-1: CLCx DATA INPUT SELECTION**

Data Input	lcxdy DxS	CLCx
LCx_in[31]	11111	Fosc
LCx_in[30]	11110	HFINTOSC
LCx_in[29]	11101	LFINTOSC
LCx_in[28]	11100	ADCRC
LCx_in[27]	11011	IOCIF set signal
LCx_in[26]	11010	T2_match
LCx_in[25]	11001	T1_overflow
LCx_in[24]	11000	T0_overflow
LCx_in[23]	10111	T6_match
LCx_in[22]	10110	T4_match
LCx_in[21]	10101	DT from EUSART
LCx_in[20]	10100	TX/CK from EUSART
LCx_in[19]	10011	ZCDx_out from Zero-Cross Detect
LCx_in[18]	10010	NCO1_out
LCx_in[17]	10001	SDO/SDA from MSSP
LCx_in[16]	10000	SCK from MSSP
LCx_in[15]	01111	PWM4_out
LCx_in[14]	01110	PWM3_out
LCx_in[13]	01101	CCP2 output
LCx_in[12]	01100	CCP1 output
LCx_in[11]	01011	COG1B
LCx_in[10]	01010	COG1A
LCx_in[9]	01001	sync_C2OUT
LCx_in[8]	01000	sync_C1OUT
LCx_in[7]	00111	LC4_out from the CLC4
LCx_in[6]	00110	LC3_out from the CLC3
LCx_in[5]	00101	LC2_out from the CLC2
LCx_in[4]	00100	LC1_out from the CLC1
LCx_in[3]	00011	CLCIN3 pin input selected in CLCIN3PPS register
LCx_in[2]	00010	CLCIN2 pin input selected in CLCIN2PPS register
LCx_in[1]	00001	CLCIN1 pin input selected in CLCIN1PPS register
LCx_in[0]	00000	CLCIN0 pin input selected in CLCIN0PPS register

# PIC16(L)F1717/8/9

## 19.1.2 DATA GATING

Outputs from the input multiplexers are directed to the desired logic function input through the data gating stage. Each data gate can direct any combination of the four selected inputs.

**Note:** Data gating is undefined at power-up.

The gate stage is more than just signal direction. The gate can be configured to direct each input signal as inverted or non-inverted data. Directed signals are ANDed together in each gate. The output of each gate can be inverted before going on to the logic function stage.

The gating is in essence a 1-to-4 input AND/NAND/OR/NOR gate. When every input is inverted and the output is inverted, the gate is an OR of all enabled data inputs. When the inputs and output are not inverted, the gate is an AND of all enabled inputs.

Table 19-2 summarizes the basic logic that can be obtained in gate 1 by using the gate logic select bits. The table shows the logic of four input variables, but each gate can be configured to use less than four. If no inputs are selected, the output will be zero or one, depending on the gate output polarity bit.

**TABLE 19-2: DATA GATING LOGIC**

CLCxGLS0	LCxG1POL	Gate Logic
0x55	1	AND
0x55	0	NAND
0xAA	1	NOR
0xAA	0	OR
0x00	0	Logic 0
0x00	1	Logic 1

It is possible (but not recommended) to select both the true and negated values of an input. When this is done, the gate output is zero, regardless of the other inputs, but may emit logic glitches (transient-induced pulses). If the output of the channel must be zero or one, the recommended method is to set all gate bits to zero and use the gate polarity bit to set the desired level.

Data gating is configured with the logic gate select registers as follows:

- Gate 1: CLCxGLS0 ([Register 19-7](#))
- Gate 2: CLCxGLS1 ([Register 19-8](#))
- Gate 3: CLCxGLS2 ([Register 19-9](#))
- Gate 4: CLCxGLS3 ([Register 19-10](#))

Register number suffixes are different than the gate numbers because other variations of this module have multiple gate selections in the same register.

Data gating is indicated in the right side of [Figure 19-2](#). Only one gate is shown in detail. The remaining three gates are configured identically with the exception that the data enables correspond to the enables for that gate.

## 19.1.3 LOGIC FUNCTION

There are eight available logic functions including:

- AND-OR
- OR-XOR
- AND
- S-R Latch
- D Flip-Flop with Set and Reset
- D Flip-Flop with Reset
- J-K Flip-Flop with Reset
- Transparent Latch with Set and Reset

Logic functions are shown in [Figure 19-3](#). Each logic function has four inputs and one output. The four inputs are the four data gate outputs of the previous stage. The output is fed to the inversion stage and from there to other peripherals, an output pin, and back to the CLCx itself.

## 19.1.4 OUTPUT POLARITY

The last stage in the configurable logic cell is the output polarity. Setting the LCxPOL bit of the CLCxCON register inverts the output signal from the logic stage. Changing the polarity while the interrupts are enabled will cause an interrupt for the resulting output transition.

## 19.1.5 CLCx SETUP STEPS

The following steps should be followed when setting up the CLCx:

- Disable CLCx by clearing the LCxEN bit.
- Select desired inputs using CLCxSEL0 through CLCxSEL3 registers (See [Table 19-1](#)).
- Clear any associated ANSEL bits.
- Set all TRIS bits associated with inputs.
- Clear all TRIS bits associated with outputs.
- Enable the chosen inputs through the four gates using CLCxGLS0, CLCxGLS1, CLCxGLS2, and CLCxGLS3 registers.
- Select the gate output polarities with the LCxPOLy bits of the CLCxPOL register.
- Select the desired logic function with the LCxMODE<2:0> bits of the CLCxCON register.
- Select the desired polarity of the logic output with the LCxPOL bit of the CLCxPOL register. (This step may be combined with the previous gate output polarity step).
- If driving a device pin, set the desired pin PPS control register and also clear the TRIS bit corresponding to that output.
- If interrupts are desired, configure the following bits:
  - Set the LCxINTP bit in the CLCxCON register for rising event.
  - Set the LCxINTN bit in the CLCxCON register for falling event.
  - Set the CLCxIE bit of the associated PIE registers.
  - Set the GIE and PEIE bits of the INTCON register.
- Enable the CLCx by setting the LCxEN bit of the CLCxCON register.

## 19.2 CLCx Interrupts

An interrupt will be generated upon a change in the output value of the CLCx when the appropriate interrupt enables are set. A rising edge detector and a falling edge detector are present in each CLC for this purpose.

The CLCxIF bit of the associated PIR registers will be set when either edge detector is triggered and its associated enable bit is set. The LCxINTP enables rising edge interrupts and the LCxINTN bit enables falling edge interrupts. Both are located in the CLCxCON register.

To fully enable the interrupt, set the following bits:

- LCxON bit of the CLCxCON register
- CLCxIE bit of the associated PIE registers
- LCxINTP bit of the CLCxCON register (for a rising edge detection)
- LCxINTN bit of the CLCxCON register (for a falling edge detection)
- PEIE and GIE bits of the INTCON register

The CLCxIF bit of the associated PIR registers, must be cleared in software as part of the interrupt service. If another edge is detected while this flag is being cleared, the flag will still be set at the end of the sequence.

## 19.3 Output Mirror Copies

Mirror copies of all LCxCON output bits are contained in the CLCxDATA register. Reading this register reads the outputs of all CLCs simultaneously. This prevents any reading skew introduced by testing or reading the CLCxOUT bits in the individual CLCxCON registers.

## 19.4 Effects of a Reset

The CLCxCON register is cleared to zero as the result of a Reset. All other selection and gating values remain unchanged.

## 19.5 Operation During Sleep

The CLC module operates independently from the system clock and will continue to run during Sleep, provided that the input sources selected remain active.

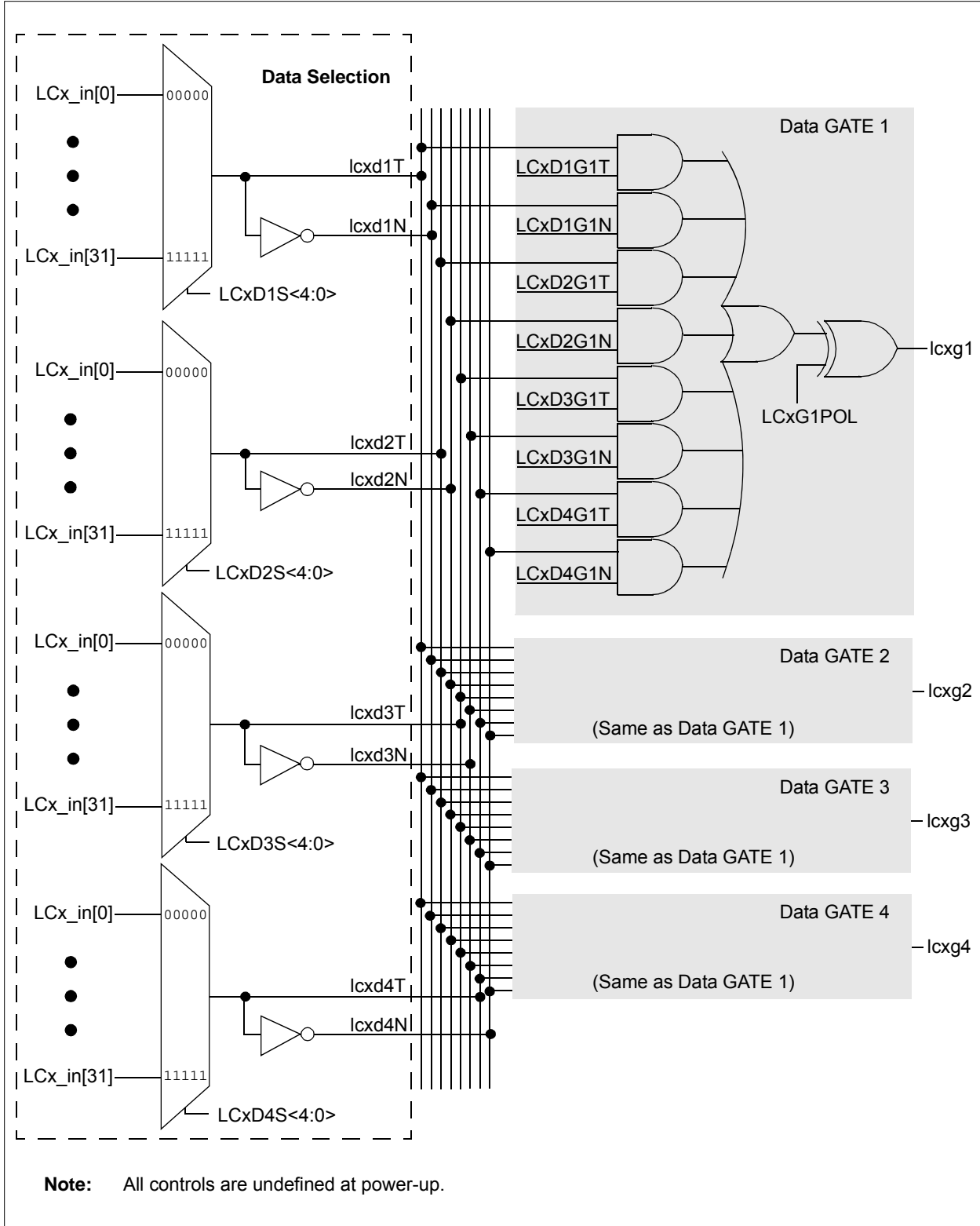
The HFINTOSC remains active during Sleep when the CLC module is enabled and the HFINTOSC is selected as an input source, regardless of the system clock source selected.

In other words, if the HFINTOSC is simultaneously selected as the system clock and as a CLC input source, when the CLC is enabled, the CPU will go idle during Sleep, but the CLC will continue to operate and the HFINTOSC will remain active.

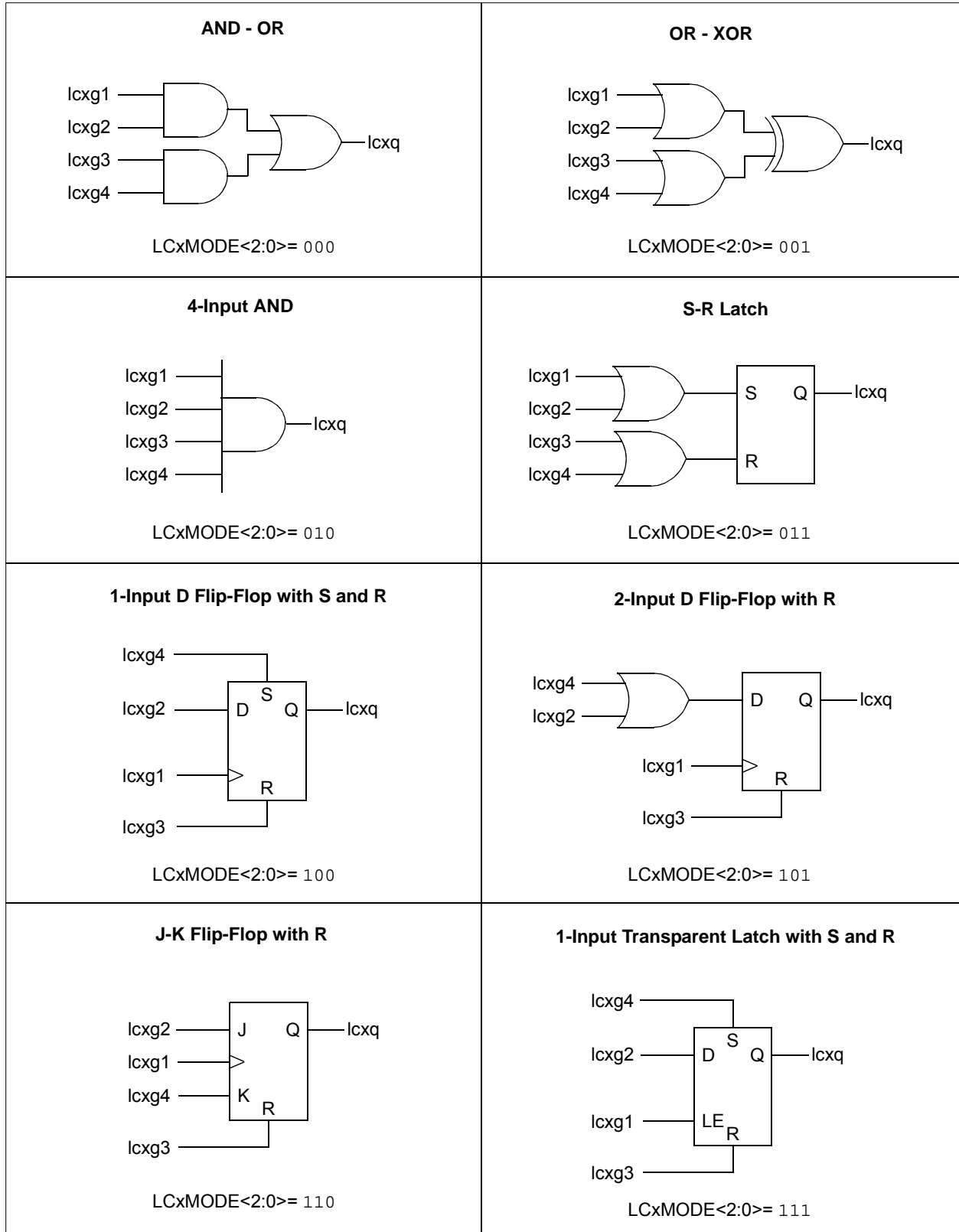
This will have a direct effect on the Sleep mode current.

# PIC16(L)F1717/8/9

**FIGURE 19-2: INPUT DATA SELECTION AND GATING**



**FIGURE 19-3: PROGRAMMABLE LOGIC FUNCTIONS**



# PIC16(L)F1717/8/9

## 19.6 Register Definitions: CLC Control

### REGISTER 19-1: CLCxCON: CONFIGURABLE LOGIC CELL CONTROL REGISTER

R/W-0/0	U-0	R-0/0	R/W-0/0	R/W-0/0	R/W-0/0	R/W-0/0	R/W-0/0
LCxEN	—	LCxOUT	LCxINTP	LCxINTN	LCxMODE<2:0>		
bit 7							bit 0

#### Legend:

R = Readable bit	W = Writable bit	U = Unimplemented bit, read as '0'
u = Bit is unchanged	x = Bit is unknown	-n/n = Value at POR and BOR/Value at all other Resets
'1' = Bit is set	'0' = Bit is cleared	

- bit 7      **LCxEN:** Configurable Logic Cell Enable bit  
 1 = Configurable logic cell is enabled and mixing input signals  
 0 = Configurable logic cell is disabled and has logic zero output
- bit 6      **Unimplemented:** Read as '0'
- bit 5      **LCxOUT:** Configurable Logic Cell Data Output bit  
 Read-only: logic cell output data, after LCxPOL; sampled from lcx\_out wire.
- bit 4      **LCxINTP:** Configurable Logic Cell Positive Edge Going Interrupt Enable bit  
 1 = CLCxIF will be set when a rising edge occurs on lcx\_out  
 0 = CLCxIF will not be set
- bit 3      **LCxINTN:** Configurable Logic Cell Negative Edge Going Interrupt Enable bit  
 1 = CLCxIF will be set when a falling edge occurs on lcx\_out  
 0 = CLCxIF will not be set
- bit 2-0    **LCxMODE<2:0>:** Configurable Logic Cell Functional Mode bits  
 111 = Cell is 1-input transparent latch with S and R  
 110 = Cell is J-K flip-flop with R  
 101 = Cell is 2-input D flip-flop with R  
 100 = Cell is 1-input D flip-flop with S and R  
 011 = Cell is S-R latch  
 010 = Cell is 4-input AND  
 001 = Cell is OR-XOR  
 000 = Cell is AND-OR



## REGISTER 19-2: CLCxPOL: SIGNAL POLARITY CONTROL REGISTER

R/W-0/0	U-0	U-0	U-0	R/W-x/u	R/W-x/u	R/W-x/u	R/W-x/u
LCxPOL	—	—	—	LCxG4POL	LCxG3POL	LCxG2POL	LCxG1POL
bit 7							bit 0

### Legend:

R = Readable bit	W = Writable bit	U = Unimplemented bit, read as '0'
u = Bit is unchanged	x = Bit is unknown	-n/n = Value at POR and BOR/Value at all other Resets
'1' = Bit is set	'0' = Bit is cleared	

- bit 7      **LCxPOL:** LCOOUT Polarity Control bit  
 1 = The output of the logic cell is inverted  
 0 = The output of the logic cell is not inverted
- bit 6-4    **Unimplemented:** Read as '0'
- bit 3      **LCxG4POL:** Gate 4 Output Polarity Control bit  
 1 = The output of gate 4 is inverted when applied to the logic cell  
 0 = The output of gate 4 is not inverted
- bit 2      **LCxG3POL:** Gate 3 Output Polarity Control bit  
 1 = The output of gate 3 is inverted when applied to the logic cell  
 0 = The output of gate 3 is not inverted
- bit 1      **LCxG2POL:** Gate 2 Output Polarity Control bit  
 1 = The output of gate 2 is inverted when applied to the logic cell  
 0 = The output of gate 2 is not inverted
- bit 0      **LCxG1POL:** Gate 1 Output Polarity Control bit  
 1 = The output of gate 1 is inverted when applied to the logic cell  
 0 = The output of gate 1 is not inverted

## REGISTER 19-3: CLCxSEL0: GENERIC CLCx DATA 1 SELECT REGISTER

U-0	U-0	U-0	R/W-x/u	R/W-x/u	R/W-x/u	R/W-x/u	R/W-x/u
—	—	—	LCxD1S<4:0>				
bit 7							bit 0

### Legend:

R = Readable bit	W = Writable bit	U = Unimplemented bit, read as '0'
u = Bit is unchanged	x = Bit is unknown	-n/n = Value at POR and BOR/Value at all other Resets
'1' = Bit is set	'0' = Bit is cleared	

- bit 7-5    **Unimplemented:** Read as '0'
- bit 4-0    **LCxD1S<4:0>:** CLCx Data1 Input Selection bits  
 See [Table 19-1](#).

# PIC16(L)F1717/8/9

## REGISTER 19-4: CLCxSEL1: GENERIC CLCx DATA 2 SELECT REGISTER

U-0	U-0	U-0	R/W-x/u	R/W-x/u	R/W-x/u	R/W-x/u	R/W-x/u	
—	—	—	LCxD2S<4:0>					
bit 7							bit 0	

### Legend:

R = Readable bit                      W = Writable bit                      U = Unimplemented bit, read as '0'  
u = Bit is unchanged                  x = Bit is unknown                  -n/n = Value at POR and BOR/Value at all other Resets  
'1' = Bit is set                          '0' = Bit is cleared

bit 7-5            **Unimplemented:** Read as '0'  
bit 4-0            **LCxD2S<4:0>:** CLCx Data 2 Input Selection bits  
See [Table 19-1](#).

## REGISTER 19-5: CLCxSEL2: GENERIC CLCx DATA 3 SELECT REGISTER

U-0	U-0	U-0	R/W-x/u	R/W-x/u	R/W-x/u	R/W-x/u	R/W-x/u	
—	—	—	LCxD3S<4:0>					
bit 7							bit 0	

### Legend:

R = Readable bit                      W = Writable bit                      U = Unimplemented bit, read as '0'  
u = Bit is unchanged                  x = Bit is unknown                  -n/n = Value at POR and BOR/Value at all other Resets  
'1' = Bit is set                          '0' = Bit is cleared

bit 7-5            **Unimplemented:** Read as '0'  
bit 4-0            **LCxD3S<4:0>:** CLCx Data 3 Input Selection bits  
See [Table 19-1](#).

## REGISTER 19-6: CLCxSEL3: GENERIC CLCx DATA 4 SELECT REGISTER

U-0	U-0	U-0	R/W-x/u	R/W-x/u	R/W-x/u	R/W-x/u	R/W-x/u	
—	—	—	LCxD4S<4:0>					
bit 7							bit 0	

### Legend:

R = Readable bit                      W = Writable bit                      U = Unimplemented bit, read as '0'  
u = Bit is unchanged                  x = Bit is unknown                  -n/n = Value at POR and BOR/Value at all other Resets  
'1' = Bit is set                          '0' = Bit is cleared

bit 7-5            **Unimplemented:** Read as '0'  
bit 4-0            **LCxD4S<4:0>:** CLCx Data 4 Input Selection bits  
See [Table 19-1](#).

## REGISTER 19-7: CLCxGLS0: GATE 1 LOGIC SELECT REGISTER

R/W-x/u	R/W-x/u	R/W-x/u	R/W-x/u	R/W-x/u	R/W-x/u	R/W-x/u	R/W-x/u
LCxG1D4T	LCxG1D4N	LCxG1D3T	LCxG1D3N	LCxG1D2T	LCxG1D2N	LCxG1D1T	LCxG1D1N
bit 7							bit 0

### Legend:

R = Readable bit	W = Writable bit	U = Unimplemented bit, read as '0'
u = Bit is unchanged	x = Bit is unknown	-n/n = Value at POR and BOR/Value at all other Resets
'1' = Bit is set	'0' = Bit is cleared	

bit 7	<b>LCxG1D4T:</b> Gate 1 Data 4 True (non-inverted) bit 1 = LCxD4T is gated into LCxG1 0 = LCxD4T is not gated into LCxG1
bit 6	<b>LCxG1D4N:</b> Gate 1 Data 4 Negated (inverted) bit 1 = LCxD4N is gated into LCxG1 0 = LCxD4N is not gated into LCxG1
bit 5	<b>LCxG1D3T:</b> Gate 1 Data 3 True (non-inverted) bit 1 = LCxD3T is gated into LCxG1 0 = LCxD3T is not gated into LCxG1
bit 4	<b>LCxG1D3N:</b> Gate 1 Data 3 Negated (inverted) bit 1 = LCxD3N is gated into LCxG1 0 = LCxD3N is not gated into LCxG1
bit 3	<b>LCxG1D2T:</b> Gate 1 Data 2 True (non-inverted) bit 1 = LCxD2T is gated into LCxG1 0 = LCxD2T is not gated into LCxG1
bit 2	<b>LCxG1D2N:</b> Gate 1 Data 2 Negated (inverted) bit 1 = LCxD2N is gated into LCxG1 0 = LCxD2N is not gated into LCxG1
bit 1	<b>LCxG1D1T:</b> Gate 1 Data 1 True (non-inverted) bit 1 = LCxD1T is gated into LCxG1 0 = LCxD1T is not gated into LCxG1
bit 0	<b>LCxG1D1N:</b> Gate 1 Data 1 Negated (inverted) bit 1 = LCxD1N is gated into LCxG1 0 = LCxD1N is not gated into LCxG1

# PIC16(L)F1717/8/9

## REGISTER 19-8: CLCxGLS1: GATE 2 LOGIC SELECT REGISTER

R/W-x/u	R/W-x/u	R/W-x/u	R/W-x/u	R/W-x/u	R/W-x/u	R/W-x/u	R/W-x/u
LCxG2D4T	LCxG2D4N	LCxG2D3T	LCxG2D3N	LCxG2D2T	LCxG2D2N	LCxG2D1T	LCxG2D1N
bit 7							bit 0

### Legend:

R = Readable bit

W = Writable bit

U = Unimplemented bit, read as '0'

u = Bit is unchanged

x = Bit is unknown

-n/n = Value at POR and BOR/Value at all other Resets

'1' = Bit is set

'0' = Bit is cleared

- bit 7      **LCxG2D4T:** Gate 2 Data 4 True (non-inverted) bit  
1 = LCxD4T is gated into LCxG2  
0 = LCxD4T is not gated into LCxG2
- bit 6      **LCxG2D4N:** Gate 2 Data 4 Negated (inverted) bit  
1 = LCxD4N is gated into LCxG2  
0 = LCxD4N is not gated into LCxG2
- bit 5      **LCxG2D3T:** Gate 2 Data 3 True (non-inverted) bit  
1 = LCxD3T is gated into LCxG2  
0 = LCxD3T is not gated into LCxG2
- bit 4      **LCxG2D3N:** Gate 2 Data 3 Negated (inverted) bit  
1 = LCxD3N is gated into LCxG2  
0 = LCxD3N is not gated into LCxG2
- bit 3      **LCxG2D2T:** Gate 2 Data 2 True (non-inverted) bit  
1 = LCxD2T is gated into LCxG2  
0 = LCxD2T is not gated into LCxG2
- bit 2      **LCxG2D2N:** Gate 2 Data 2 Negated (inverted) bit  
1 = LCxD2N is gated into LCxG2  
0 = LCxD2N is not gated into LCxG2
- bit 1      **LCxG2D1T:** Gate 2 Data 1 True (non-inverted) bit  
1 = LCxD1T is gated into LCxG2  
0 = LCxD1T is not gated into LCxG2
- bit 0      **LCxG2D1N:** Gate 2 Data 1 Negated (inverted) bit  
1 = LCxD1N is gated into LCxG2  
0 = LCxD1N is not gated into LCxG2

## REGISTER 19-9: CLCxGLS2: GATE 3 LOGIC SELECT REGISTER

R/W-x/u	R/W-x/u	R/W-x/u	R/W-x/u	R/W-x/u	R/W-x/u	R/W-x/u	R/W-x/u
LCxG3D4T	LCxG3D4N	LCxG3D3T	LCxG3D3N	LCxG3D2T	LCxG3D2N	LCxG3D1T	LCxG3D1N
bit 7							bit 0

### Legend:

R = Readable bit

W = Writable bit

U = Unimplemented bit, read as '0'

u = Bit is unchanged

x = Bit is unknown

-n/n = Value at POR and BOR/Value at all other Resets

'1' = Bit is set

'0' = Bit is cleared

- bit 7      **LCxG3D4T:** Gate 3 Data 4 True (non-inverted) bit  
 1 = LCxD4T is gated into LCxG3  
 0 = LCxD4T is not gated into LCxG3
- bit 6      **LCxG3D4N:** Gate 3 Data 4 Negated (inverted) bit  
 1 = LCxD4N is gated into LCxG3  
 0 = LCxD4N is not gated into LCxG3
- bit 5      **LCxG3D3T:** Gate 3 Data 3 True (non-inverted) bit  
 1 = LCxD3T is gated into LCxG3  
 0 = LCxD3T is not gated into LCxG3
- bit 4      **LCxG3D3N:** Gate 3 Data 3 Negated (inverted) bit  
 1 = LCxD3N is gated into LCxG3  
 0 = LCxD3N is not gated into LCxG3
- bit 3      **LCxG3D2T:** Gate 3 Data 2 True (non-inverted) bit  
 1 = LCxD2T is gated into LCxG3  
 0 = LCxD2T is not gated into LCxG3
- bit 2      **LCxG3D2N:** Gate 3 Data 2 Negated (inverted) bit  
 1 = LCxD2N is gated into LCxG3  
 0 = LCxD2N is not gated into LCxG3
- bit 1      **LCxG3D1T:** Gate 3 Data 1 True (non-inverted) bit  
 1 = LCxD1T is gated into LCxG3  
 0 = LCxD1T is not gated into LCxG3
- bit 0      **LCxG3D1N:** Gate 3 Data 1 Negated (inverted) bit  
 1 = LCxD1N is gated into LCxG3  
 0 = LCxD1N is not gated into LCxG3

# PIC16(L)F1717/8/9

## REGISTER 19-10: CLCxGLS3: GATE 4 LOGIC SELECT REGISTER

R/W-x/u	R/W-x/u	R/W-x/u	R/W-x/u	R/W-x/u	R/W-x/u	R/W-x/u	R/W-x/u
LCxG4D4T	LCxG4D4N	LCxG4D3T	LCxG4D3N	LCxG4D2T	LCxG4D2N	LCxG4D1T	LCxG4D1N
bit 7							bit 0

### Legend:

R = Readable bit

W = Writable bit

U = Unimplemented bit, read as '0'

u = Bit is unchanged

x = Bit is unknown

-n/n = Value at POR and BOR/Value at all other Resets

'1' = Bit is set

'0' = Bit is cleared

- bit 7      **LCxG4D4T:** Gate 4 Data 4 True (non-inverted) bit  
1 = LCxD4T is gated into LCxG4  
0 = LCxD4T is not gated into LCxG4
- bit 6      **LCxG4D4N:** Gate 4 Data 4 Negated (inverted) bit  
1 = LCxD4N is gated into LCxG4  
0 = LCxD4N is not gated into LCxG4
- bit 5      **LCxG4D3T:** Gate 4 Data 3 True (non-inverted) bit  
1 = LCxD3T is gated into LCxG4  
0 = LCxD3T is not gated into LCxG4
- bit 4      **LCxG4D3N:** Gate 4 Data 3 Negated (inverted) bit  
1 = LCxD3N is gated into LCxG4  
0 = LCxD3N is not gated into LCxG4
- bit 3      **LCxG4D2T:** Gate 4 Data 2 True (non-inverted) bit  
1 = LCxD2T is gated into LCxG4  
0 = LCxD2T is not gated into LCxG4
- bit 2      **LCxG4D2N:** Gate 4 Data 2 Negated (inverted) bit  
1 = LCxD2N is gated into LCxG4  
0 = LCxD2N is not gated into LCxG4
- bit 1      **LCxG4D1T:** Gate 4 Data 1 True (non-inverted) bit  
1 = LCxD1T is gated into LCxG4  
0 = LCxD1T is not gated into LCxG4
- bit 0      **LCxG4D1N:** Gate 4 Data 1 Negated (inverted) bit  
1 = LCxD1N is gated into LCxG4  
0 = LCxD1N is not gated into LCxG4

# PIC16(L)F1717/8/9

## REGISTER 19-11: CLCDATA: CLC DATA OUTPUT

U-0	U-0	U-0	U-0	R-0	R-0	R-0	R-0
—	—	—	—	MCL4OUT	MLC3OUT	MLC2OUT	MLC1OUT
bit 7							bit 0

### Legend:

R = Readable bit	W = Writable bit	U = Unimplemented bit, read as '0'
u = Bit is unchanged	x = Bit is unknown	-n/n = Value at POR and BOR/Value at all other Resets
'1' = Bit is set	'0' = Bit is cleared	

bit 7-4	Unimplemented: Read as '0'
bit 3	MCL4OUT: Mirror copy of LC4OUT bit
bit 2	MLC3OUT: Mirror copy of LC3OUT bit
bit 1	MLC2OUT: Mirror copy of LC2OUT bit
bit 0	MLC1OUT: Mirror copy of LC1OUT bit

**TABLE 19-3: SUMMARY OF REGISTERS ASSOCIATED WITH CLCx**

Name	Bit7	Bit6	Bit5	Bit4	Bit3	Bit2	Bit1	Bit0	Register on Page
ANSELA	—	—	ANSA5	ANSA4	ANSA3	ANSA2	ANSA1	ANSA0	125
ANSELB	—	—	ANSB5	ANSB4	ANSB3	ANSB2	ANSB1	ANSB0	131
ANSELC	ANSC7	ANSC6	ANSC5	ANSC4	ANSC3	ANSC2	—	—	136
ANSELD <sup>(1)</sup>	ANS7	ANS6	ANS5	ANS4	ANS3	ANS2	ANS1	ANS0	141
CLC1CON	LC1EN	—	LC1OUT	LC1INTP	LC1INTN	LC1MODE<2:0>			224
CLC2CON	LC2EN	—	LC2OUT	LC2INTP	LC2INTN	LC2MODE<2:0>			224
CLC3CON	LC3EN	—	LC3OUT	LC3INTP	LC3INTN	LC3MODE<2:0>			224
CLCDATA	—	—	—	—	MCL4OUT	MLC3OUT	MLC2OUT	MLC1OUT	231
CLC1GLS0	LC1G1D4T	LC1G1D4N	LC1G1D3T	LC1G1D3N	LC1G1D2T	LC1G1D2N	LC1G1D1T	LC1G1D1N	227
CLC1GLS1	LC1G2D4T	LC1G2D4N	LC1G2D3T	LC1G2D3N	LC1G2D2T	LC1G2D2N	LC1G2D1T	LC1G2D1N	228
CLC1GLS2	LC1G3D4T	LC1G3D4N	LC1G3D3T	LC1G3D3N	LC1G3D2T	LC1G3D2N	LC1G3D1T	LC1G3D1N	229
CLC1GLS3	LC1G4D4T	LC1G4D4N	LC1G4D3T	LC1G4D3N	LC1G4D2T	LC1G4D2N	LC1G4D1T	LC1G4D1N	230
CLC1POL	LC1POL	—	—	—	LC1G4POL	LC1G3POL	LC1G2POL	LC1G1POL	225
CLC1SEL0	—	—	—	LC1D1S<4:0>					225
CLC1SEL1	—	—	—	LC1D2S<4:0>					226
CLC1SEL2	—	—	—	LC1D3S<4:0>					226
CLC1SEL3	—	—	—	LC1D4S<4:0>					226
CLC2GLS0	LC2G1D4T	LC2G1D4N	LC2G1D3T	LC2G1D3N	LC2G1D2T	LC2G1D2N	LC2G1D1T	LC2G1D1N	227
CLC2GLS1	LC2G2D4T	LC2G2D4N	LC2G2D3T	LC2G2D3N	LC2G2D2T	LC2G2D2N	LC2G2D1T	LC2G2D1N	228
CLC2GLS2	LC2G3D4T	LC2G3D4N	LC2G3D3T	LC2G3D3N	LC2G3D2T	LC2G3D2N	LC2G3D1T	LC2G3D1N	229
CLC2GLS3	LC2G4D4T	LC2G4D4N	LC2G4D3T	LC2G4D3N	LC2G4D2T	LC2G4D2N	LC2G4D1T	LC2G4D1N	230
CLC2POL	LC2POL	—	—	—	LC2G4POL	LC2G3POL	LC2G2POL	LC2G1POL	225
CLC2SEL0	—	—	—	LC2D1S<4:0>					225
CLC2SEL1	—	—	—	LC2D2S<4:0>					226
CLC2SEL2	—	—	—	LC2D3S<4:0>					226

**Legend:** — = unimplemented read as '0'. Shaded cells are not used for CLC module.

**Note 1:** PIC16(L)F1717/9 only.

# PIC16(L)F1717/8/9

**TABLE 19-3: SUMMARY OF REGISTERS ASSOCIATED WITH CLCx (CONTINUED)**

Name	Bit7	Bit6	Bit5	Bit4	Bit3	Bit2	Bit1	Bit0	Register on Page
CLC2SEL3	—	—	—	LC2D4S<4:0>					226
CLC3GLS0	LC3G1D4T	LC3G1D4N	LC3G1D3T	LC3G1D3N	LC3G1D2T	LC3G1D2N	LC3G1D1T	LC3G1D1N	227
CLC3GLS1	LC3G2D4T	LC3G2D4N	LC3G2D3T	LC3G2D3N	LC3G2D2T	LC3G2D2N	LC3G2D1T	LC3G2D1N	228
CLC3GLS2	LC3G3D4T	LC3G3D4N	LC3G3D3T	LC3G3D3N	LC3G3D2T	LC3G3D2N	LC3G3D1T	LC3G3D1N	229
CLC3GLS3	LC3G4D4T	LC3G4D4N	LC3G4D3T	LC3G4D3N	LC3G4D2T	LC3G4D2N	LC3G4D1T	LC3G4D1N	230
CLC3POL	LC3POL	—	—	—	LC3G4POL	LC3G3POL	LC3G2POL	LC3G1POL	225
CLC3SEL0	—	—	—	LC3D1S<4:0>					225
CLC3SEL1	—	—	—	LC3D2S<4:0>					226
CLC3SEL2	—	—	—	LC3D3S<4:0>					226
CLC3SEL3	—	—	—	LC3D4S<4:0>					226
CLC4GLS0	LC4G1D4T	LC4G1D4N	LC4G1D3T	LC4G1D3N	LC4G1D2T	LC4G1D2N	LC4G1D1T	LC4G1D1N	227
CLC4GLS1	LC4G2D4T	LC4G2D4N	LC4G2D3T	LC4G2D3N	LC4G2D2T	LC4G2D2N	LC4G2D1T	LC4G2D1N	228
CLC4GLS2	LC4G3D4T	LC4G3D4N	LC4G3D3T	LC4G3D3N	LC4G3D2T	LC4G3D2N	LC4G3D1T	LC4G3D1N	229
CLC4GLS3	LC4G4D4T	LC4G4D4N	LC4G4D3T	LC4G4D3N	LC4G4D2T	LC4G4D2N	LC4G4D1T	LC4G4D1N	230
CLC4POL	LC4POL	—	—	—	LC4G4POL	LC4G3POL	LC4G2POL	LC4G1POL	225
CLC4SEL0	—	—	—	LC4D1S<4:0>					225
CLC4SEL1	—	—	—	LC4D2S<4:0>					226
CLC4SEL2	—	—	—	LC4D3S<4:0>					226
CLC4SEL3	—	—	—	LC4D4S<4:0>					226
CLCxPPS	—	—	—	CLCxPPS<4:0>					152
INTCON	GIE	PEIE	TMR0IE	INTE	IOCFIE	TMR0IF	INTF	IOCFIF	90
PIE3	—	NCOIE	COGIE	ZCDIE	CLC4IE	CLC3IE	CLC2IE	CLC1IE	93
PIR3	—	NCOIF	COGIF	ZCDIF	CLC4IF	CLC3IF	CLC2IF	CLC1IF	96
RxyPPS	—	—	—	RxyPPS<4:0>					153
TRISA	TRISA7	TRISA6	TRISA5	TRISA4	TRISA3	TRISA2	TRISA1	TRISA0	124
TRISB	TRISB7	TRISB6	TRISB5	TRISB4	TRISB3	TRISB2	TRISB1	TRISB0	130
TRISC	TRISC7	TRISC6	TRISC5	TRISC4	TRISC3	TRISC2	TRISC1	TRISC0	135
TRISD <sup>(1)</sup>	TRISD7	TRISD6	TRISD5	TRISD4	TRISD3	TRISD2	TRISD1	TRISD0	140

**Legend:** — = unimplemented read as '0'. Shaded cells are not used for CLC module.

**Note 1:** PIC16(L)F1717/9 only.



## 20.0 NUMERICALLY CONTROLLED OSCILLATOR (NCO) MODULE

The Numerically Controlled Oscillator (NCOx) module is a timer that uses the overflow from the addition of an increment value to divide the input frequency. The advantage of the addition method over simple counter driven timer is that the resolution of division does not vary with the divider value. The NCOx is most useful for applications that require frequency accuracy and fine resolution at a fixed duty cycle.

Features of the NCOx include:

- 20-bit increment function
- Fixed Duty Cycle (FDC) mode
- Pulse Frequency (PF) mode
- Output pulse width control
- Multiple clock input sources
- Output polarity control
- Interrupt capability

Figure 20-1 is a simplified block diagram of the NCOx module.

### 20.1 NCOx Operation

The NCOx operates by repeatedly adding a fixed value to an accumulator. Additions occur at the input clock rate. The accumulator will overflow with a carry periodically, which is the raw NCOx output (NCO\_overflow). This effectively reduces the input clock by the ratio of the addition value to the maximum accumulator value. See Equation 20-1.

The NCOx output can be further modified by stretching the pulse or toggling a flip-flop. The modified NCOx output is then distributed internally to other peripherals and optionally output to a pin. The accumulator overflow also generates an interrupt (NCO\_interrupt).

The NCOx period changes in discrete steps to create an average frequency. This output depends on the ability of the receiving circuit (i.e., CWG or external resonant converter circuitry) to average the NCOx output to reduce uncertainty.

#### 20.1.1 NCOx CLOCK SOURCES

Clock sources available to the NCOx include:

- HFINTOSC
- Fosc
- LC3\_out

The NCOx clock source is selected by configuring the NxCKS<2:0> bits in the NCOxCLK register.

#### 20.1.2 ACCUMULATOR

The accumulator is a 20-bit register. Read and write access to the accumulator is available through three registers:

- NCOxACCL
- NCOxACCH
- NCOxACCU

#### 20.1.3 ADDER

The NCOx adder is a full adder, which operates independently from the system clock. The addition of the previous result and the increment value replaces the accumulator value on the rising edge of each input clock.

#### 20.1.4 INCREMENT REGISTERS

The increment value is stored in three registers making up a 20-bit increment. In order of LSB to MSB they are:

- NCOxINCL
- NCOxINCH
- NCOxINCU

When the NCO module is enabled, the NCOxINCU and NCOxINCH registers should be written first, then the NCOxINCL register. Writing to the NCOxINCL register initiates the increment buffer registers to be loaded simultaneously on the second rising edge of the NCOx\_clk signal.

The registers are readable and writable. The increment registers are double-buffered to allow value changes to be made without first disabling the NCOx module.

When the NCO module is disabled, the increment buffers are loaded immediately after a write to the increment registers.

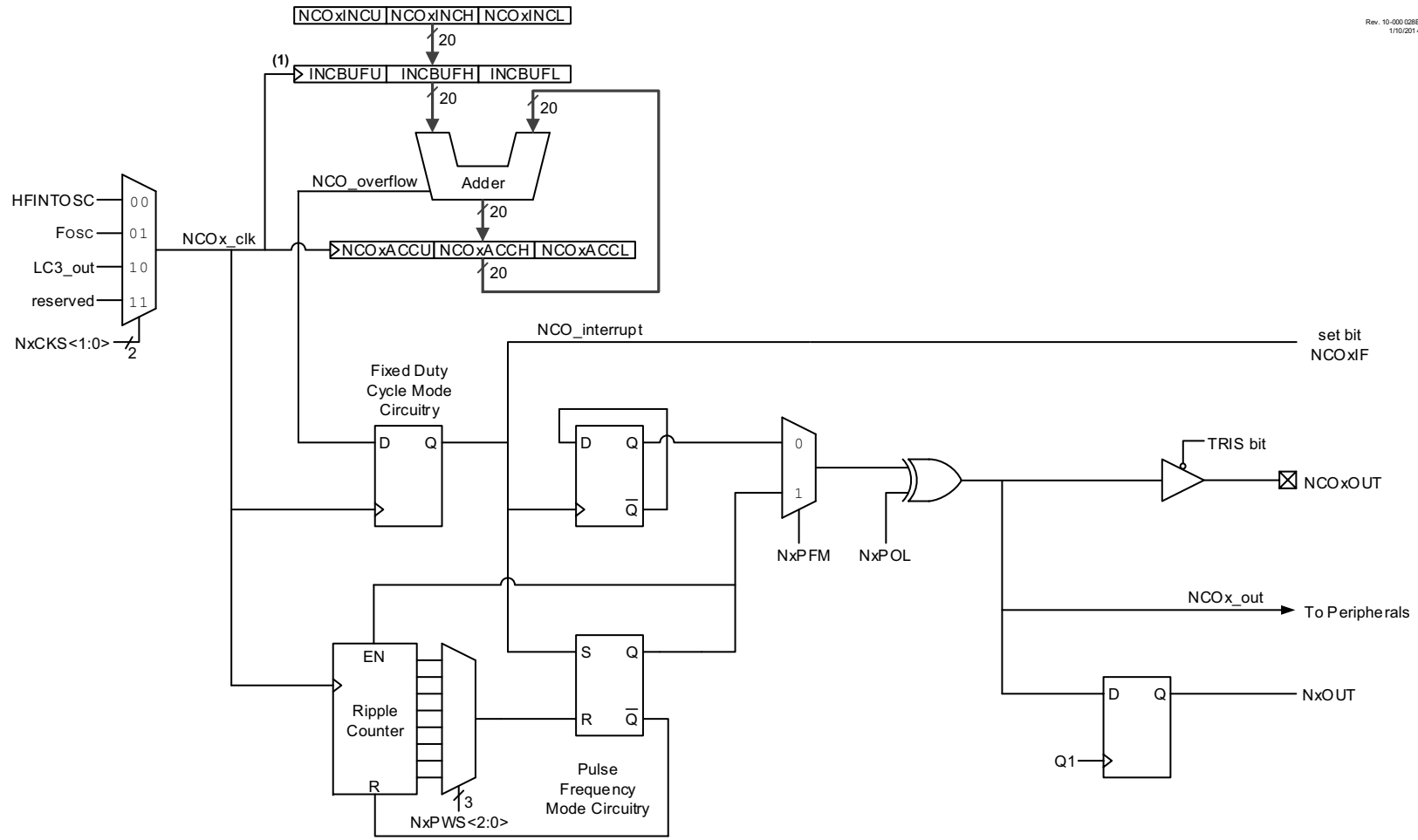
**Note:** The increment buffer registers are not user-accessible.

### EQUATION 20-1:

$$F_{OVERFLOW} = \frac{\text{NCO Clock Frequency} \times \text{Increment Value}}{2^n}$$

*n* = Accumulator width in bits

**FIGURE 20-1: NUMERICALLY CONTROLLED OSCILLATOR (NCOx) MODULE SIMPLIFIED BLOCK DIAGRAM**



Rev. 10-000129B  
1/10/2014

**Note 1:** The increment registers are double-buffered to allow for value changes to be made without first disabling the NCO module. The full increment value is loaded into the buffer registers on the second rising edge of the `NCOx_clk` signal that occurs immediately after a write to `NCOxINCL` register. The buffers are not user-accessible and are shown here for reference.

## 20.2 Fixed Duty Cycle (FDC) Mode

In Fixed Duty Cycle (FDC) mode, every time the accumulator overflows (NCO\_overflow), the output is toggled. This provides a 50% duty cycle, provided that the increment value remains constant. For more information, see [Figure 20-2](#).

The FDC mode is selected by clearing the NxPFM bit in the NCOxCON register.

## 20.3 Pulse Frequency (PF) Mode

In Pulse Frequency (PF) mode, every time the accumulator overflows (NCO\_overflow), the output becomes active for one or more clock periods. Once the clock period expires, the output returns to an inactive state. This provides a pulsed output.

The output becomes active on the rising clock edge immediately following the overflow event. For more information, see [Figure 20-2](#).

The value of the active and inactive states depends on the polarity bit, NxPOL in the NCOxCON register.

The PF mode is selected by setting the NxPFM bit in the NCOxCON register.

### 20.3.1 OUTPUT PULSE WIDTH CONTROL

When operating in PF mode, the active state of the output can vary in width by multiple clock periods. Various pulse widths are selected with the NxPWS<2:0> bits in the NCOxCLK register.

When the selected pulse width is greater than the accumulator overflow time frame, the output of the NCOx operation is indeterminate.

## 20.4 Output Polarity Control

The last stage in the NCOx module is the output polarity. The NxPOL bit in the NCOxCON register selects the output polarity. Changing the polarity while the interrupts are enabled will cause an interrupt for the resulting output transition.

The NCOx output can be used internally by source code or other peripherals. Accomplish this by reading the NxOUT (read-only) bit of the NCOxCON register.

The NCOx output signal is available to the following peripherals:

- CLC
- CWG

## 20.5 Interrupts

When the accumulator overflows (NCO\_overflow), the NCOx Interrupt Flag bit, NCOxIF, of the PIRx register is set. To enable the interrupt event (NCO\_interrupt), the following bits must be set:

- NxEN bit of the NCOxCON register
- NCOxIE bit of the PIEx register
- PEIE bit of the INTCON register
- GIE bit of the INTCON register

The interrupt must be cleared by software by clearing the NCOxIF bit in the Interrupt Service Routine.

## 20.6 Effects of a Reset

All of the NCOx registers are cleared to zero as the result of a Reset.

## 20.7 Operation in Sleep

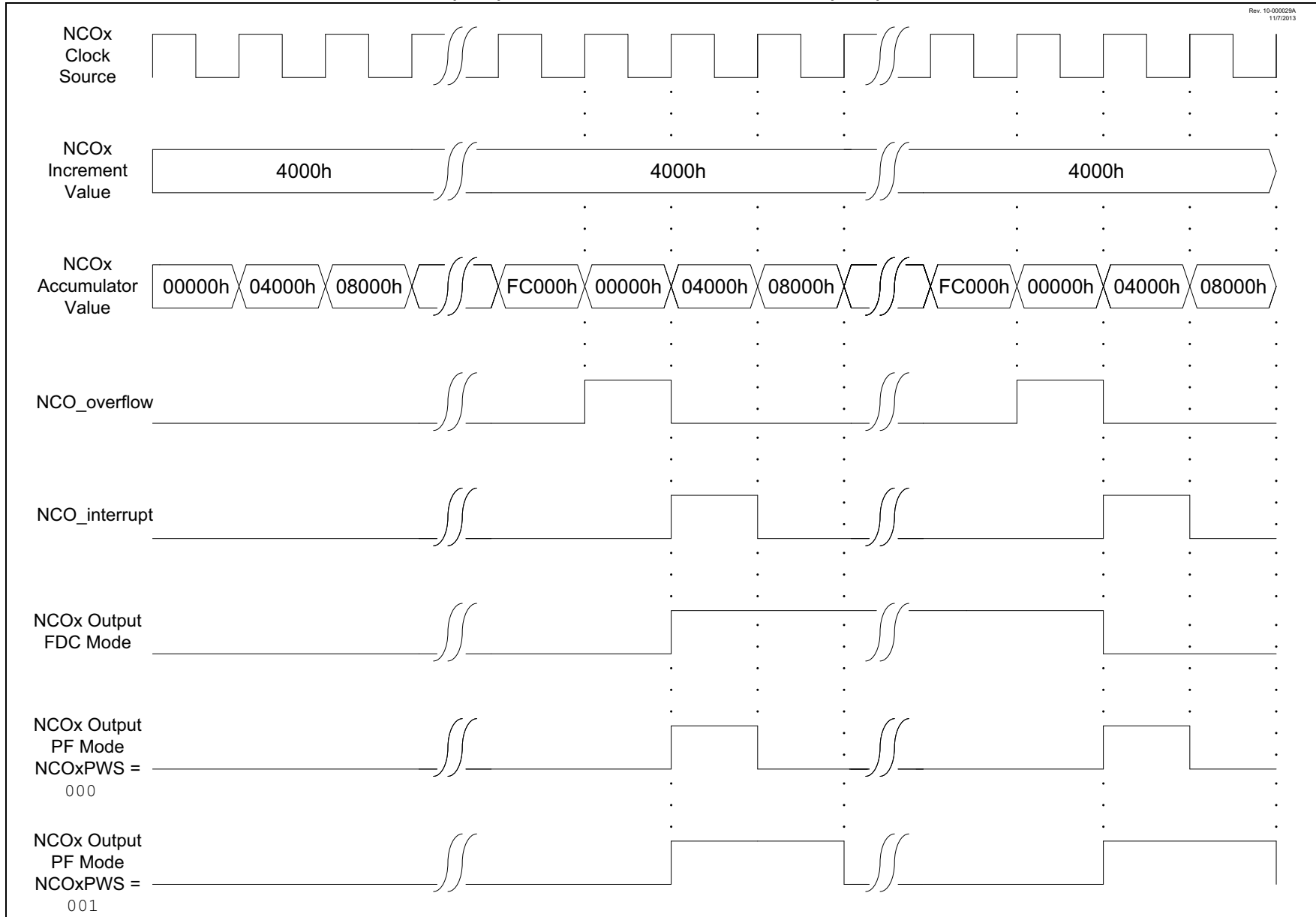
The NCO module operates independently from the system clock and will continue to run during Sleep, provided that the clock source selected remains active.

The HFINTOSC remains active during Sleep when the NCO module is enabled and the HFINTOSC is selected as the clock source, regardless of the system clock source selected.

In other words, if the HFINTOSC is simultaneously selected as the system clock and the NCO clock source, when the NCO is enabled, the CPU will go idle during Sleep, but the NCO will continue to operate and the HFINTOSC will remain active.

This will have a direct effect on the Sleep mode current.

**FIGURE 20-2: NCO – FIXED DUTY CYCLE (FDC) AND PULSE FREQUENCY MODE (PFM) OUTPUT OPERATION DIAGRAM**



## 20.8 Register Definitions: NCOx Control Registers

### REGISTER 20-1: NCOxCON: NCOx CONTROL REGISTER

R/W-0/0	U-0	R-0/0	R/W-0/0	U-0	U-0	U-0	R/W-0/0
NxEN	—	NxOUT	NxPOL	—	—	—	NxPFM
bit 7							bit 0

#### Legend:

R = Readable bit	W = Writable bit	U = Unimplemented bit, read as '0'
u = Bit is unchanged	x = Bit is unknown	-n/n = Value at POR and BOR/Value at all other Resets
'1' = Bit is set	'0' = Bit is cleared	

bit 7	<b>NxEN:</b> NCOx Enable bit 1 = NCOx module is enabled 0 = NCOx module is disabled
bit 6	<b>Unimplemented:</b> Read as '0'
bit 5	<b>NxOUT:</b> NCOx Output bit 1 = NCOx output is high 0 = NCOx output is low
bit 4	<b>NxPOL:</b> NCOx Polarity bit 1 = NCOx output signal is active-low (inverted) 0 = NCOx output signal is active-high (non-inverted)
bit 3-1	<b>Unimplemented:</b> Read as '0'
bit 0	<b>NxPFM:</b> NCOx Pulse Frequency Mode bit 1 = NCOx operates in Pulse Frequency mode 0 = NCOx operates in Fixed Duty Cycle mode

# PIC16(L)F1717/8/9

## REGISTER 20-2: NCOxCLK: NCOx INPUT CLOCK CONTROL REGISTER

R/W-0/0	R/W-0/0	R/W-0/0	U-0	U-0	U-0	R/W-0/0	R/W-0/0
NxPWS<2:0> <sup>(1, 2)</sup>			—	—	—	NxCKS<1:0>	
bit 7						bit 0	

### Legend:

R = Readable bit	W = Writable bit	U = Unimplemented bit, read as '0'
u = Bit is unchanged	x = Bit is unknown	-n/n = Value at POR and BOR/Value at all other Resets
'1' = Bit is set	'0' = Bit is cleared	

bit 7-5 **NxPWS<2:0>**: NCOx Output Pulse Width Select bits<sup>(1, 2)</sup>

111 = 128 NCOx clock periods  
 110 = 64 NCOx clock periods  
 101 = 32 NCOx clock periods  
 100 = 16 NCOx clock periods  
 011 = 8 NCOx clock periods  
 010 = 4 NCOx clock periods  
 001 = 2 NCOx clock periods  
 000 = 1 NCOx clock periods

bit 4-2 **Unimplemented**: Read as '0'

bit 1-0 **NxCKS<1:0>**: NCOx Clock Source Select bits

11 = Reserved  
 10 = LC3\_out  
 01 = FOSC  
 00 = HFINTOSC (16 MHz)

**Note 1:** NxPWS applies only when operating in Pulse Frequency mode.

**2:** If NCOx pulse width is greater than NCO\_overflow period, operation is undeterminate.

## REGISTER 20-3: NCOxACCL: NCOx ACCUMULATOR REGISTER – LOW BYTE

R/W-0/0	R/W-0/0	R/W-0/0	R/W-0/0	R/W-0/0	R/W-0/0	R/W-0/0	R/W-0/0
NCOxACC<7:0>							
bit 7						bit 0	

### Legend:

R = Readable bit	W = Writable bit	U = Unimplemented bit, read as '0'
u = Bit is unchanged	x = Bit is unknown	-n/n = Value at POR and BOR/Value at all other Resets
'1' = Bit is set	'0' = Bit is cleared	

bit 7-0 **NCOxACC<7:0>**: NCOx Accumulator, Low Byte

## REGISTER 20-4: NCOxACCCH: NCOx ACCUMULATOR REGISTER – HIGH BYTE

R/W-0/0	R/W-0/0	R/W-0/0	R/W-0/0	R/W-0/0	R/W-0/0	R/W-0/0	R/W-0/0
NCOxACC<15:8>							
bit 7							bit 0

### Legend:

R = Readable bit	W = Writable bit	U = Unimplemented bit, read as '0'
u = Bit is unchanged	x = Bit is unknown	-n/n = Value at POR and BOR/Value at all other Resets
'1' = Bit is set	'0' = Bit is cleared	

bit 7-0      **NCOxACC<15:8>**: NCOx Accumulator, High Byte

## REGISTER 20-5: NCOxACCU: NCOx ACCUMULATOR REGISTER – UPPER BYTE

U-0	U-0	U-0	U-0	R/W-0/0	R/W-0/0	R/W-0/0	R/W-0/0
—	—	—	—	NCOxACC<19:16>			
bit 7							bit 0

### Legend:

R = Readable bit	W = Writable bit	U = Unimplemented bit, read as '0'
u = Bit is unchanged	x = Bit is unknown	-n/n = Value at POR and BOR/Value at all other Resets
'1' = Bit is set	'0' = Bit is cleared	

bit 7-4      **Unimplemented:** Read as '0'

bit 3-0      **NCOxACC<19:16>**: NCOx Accumulator, Upper Byte

## REGISTER 20-6: NCOxINCL: NCOx INCREMENT REGISTER – LOW BYTE<sup>(1)</sup>

R/W-0/0	R/W-0/0	R/W-0/0	R/W-0/0	R/W-0/0	R/W-0/0	R/W-0/0	R/W-1/1
NCOxINC<7:0>							
bit 7							bit 0

### Legend:

R = Readable bit	W = Writable bit	U = Unimplemented bit, read as '0'
u = Bit is unchanged	x = Bit is unknown	-n/n = Value at POR and BOR/Value at all other Resets
'1' = Bit is set	'0' = Bit is cleared	

bit 7-0      **NCOxINC<7:0>**: NCOx Increment, Low Byte

**Note 1:** Write the NCOxINCH register first, then the NCOxINCL register. See [Section 20.1.4 “Increment Registers”](#) for more information.

# PIC16(L)F1717/8/9

## REGISTER 20-7: NCOxINCH: NCOx INCREMENT REGISTER – HIGH BYTE<sup>(1)</sup>

R/W-0/0	R/W-0/0	R/W-0/0	R/W-0/0	R/W-0/0	R/W-0/0	R/W-0/0	R/W-0/0
NCOxINC<15:8>							
bit 7							bit 0

### Legend:

R = Readable bit                      W = Writable bit                      U = Unimplemented bit, read as '0'  
u = Bit is unchanged                  x = Bit is unknown                      -n/n = Value at POR and BOR/Value at all other Resets  
'1' = Bit is set                          '0' = Bit is cleared

bit 7-0                  **NCOxINC<15:8>**: NCOx Increment, High Byte

**Note 1:** Write the NCOxINCH register first, then the NCOxINCL register. See [Section 20.1.4 “Increment Registers”](#) for more information.

## REGISTER 20-8: NCOxINCUC: NCOx INCREMENT REGISTER – UPPER BYTE<sup>(1)</sup>

U-0	U-0	U-0	U-0	R/W-0/0	R/W-0/0	R/W-0/0	R/W-0/0
—	—	—	—	NCOxINC<19:16>			
bit 7							bit 0

### Legend:

R = Readable bit                      W = Writable bit                      U = Unimplemented bit, read as '0'  
u = Bit is unchanged                  x = Bit is unknown                      -n/n = Value at POR and BOR/Value at all other Resets  
'1' = Bit is set                          '0' = Bit is cleared

bit 7-4                  **Unimplemented:** Read as '0'

bit 3-0                  **NCOxINC<19:16>**: NCOx Increment, Upper Byte

**Note 1:** Write the NCOxINCUC register first, then the NCOxINCL register. See [Section 20.1.4 “Increment Registers”](#) for more information.



**TABLE 20-1: SUMMARY OF REGISTERS ASSOCIATED WITH NCO<sub>x</sub>**

Name	Bit 7	Bit 6	Bit 5	Bit 4	Bit 3	Bit 2	Bit 1	Bit 0	Register on Page	
INTCON	GIE	PEIE	TMR0IE	INTE	IOCFE	TMR0IF	INTF	IOCF	90	
NCO1ACCU	—			NCO1ACC<19:16>						239
NCO1ACCH	NCO1ACC<15:8>								239	
NCO1ACCL	NCO1ACC<7:0>								238	
NCO1CLK	N1PWS<2:0>			—	—	—	N1CKS<1:0>			238
NCO1CON	N1EN	—	N1OUT	N1POL	—	—	—	N1PFM	237	
NCO1INC	—			NCO1INC<19:16>						240
NCO1INCH	NCO1INC<15:8>								240	
NCO1INCL	NCO1INC<7:0>								239	
PIE3	—	NCOIE	COGIE	ZCDIE	CLC4IE	CLC3IE	CLC2IE	CLC1IE	93	
PIR3	—	NCOIF	COGIF	ZCDIF	CLC4IF	CLC3IF	CLC2IF	CLC1IF	96	
TRISA	TRISA7	TRISA6	TRISA5	TRISA4	TRISA3	TRISA2	TRISA1	TRISA0	124	
TRISC	TRISC7	TRISC6	TRISC5	TRISC4	TRISC3	TRISC2	TRISC1	TRISC0	135	
TRISD <sup>(1)</sup>	TRISD7	TRISD6	TRISD5	TRISD4	TRISD3	TRISD2	TRISD1	TRISD0	140	
RxyPPS	—	—	—	RxyPPS<4:0>					153	

**Legend:** x = unknown, u = unchanged, — = unimplemented read as '0', q = value depends on condition. Shaded cells are not used for NCO<sub>x</sub> module.

**Note 1:** PIC16(L)F1717/9 only.

# PIC16(L)F1717/8/9

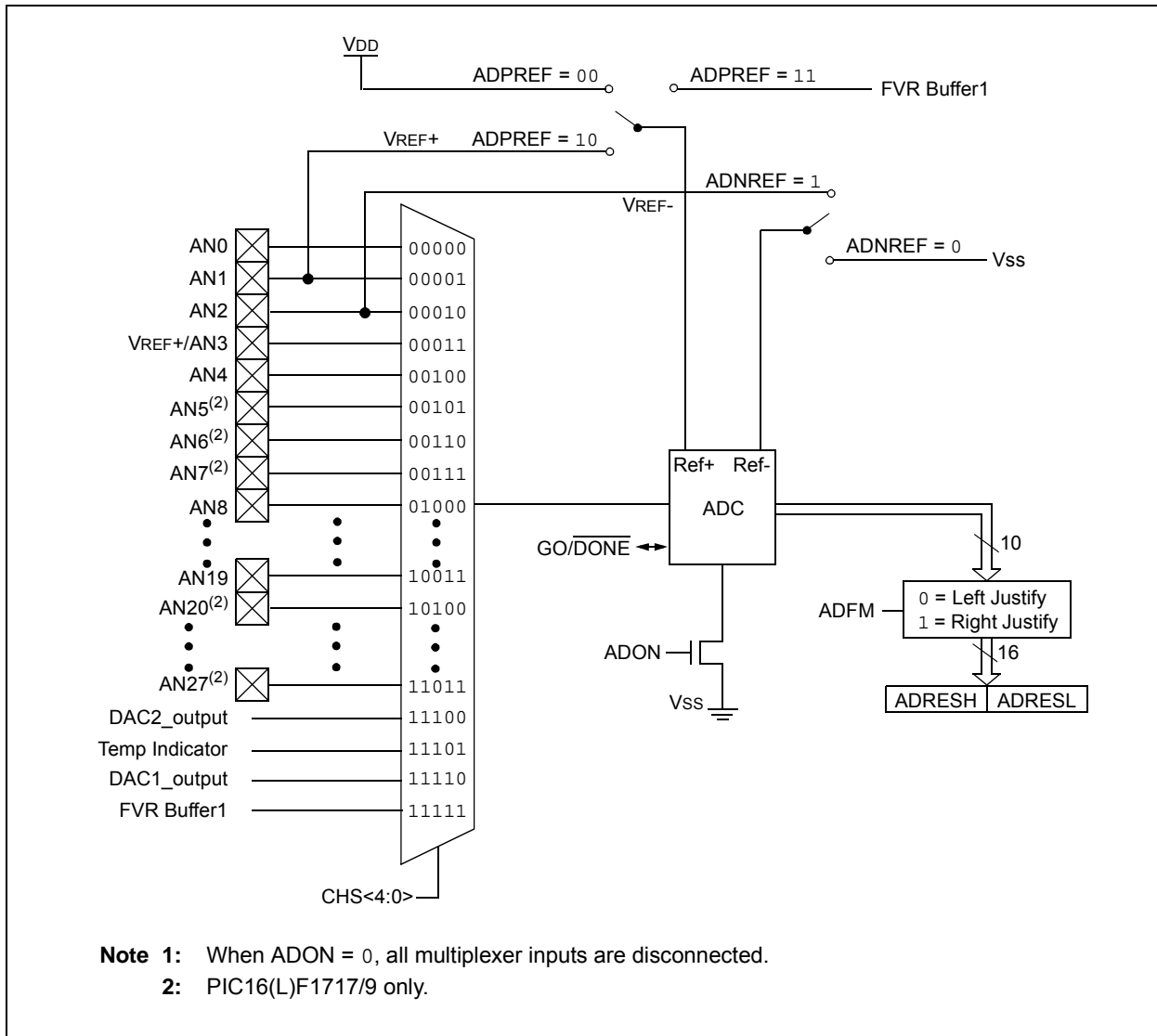
## 21.0 ANALOG-TO-DIGITAL CONVERTER (ADC) MODULE

The Analog-to-Digital Converter (ADC) allows conversion of an analog input signal to a 10-bit binary representation of that signal. This device uses analog inputs, which are multiplexed into a single sample and hold circuit. The output of the sample and hold is connected to the input of the converter. The converter generates a 10-bit binary result via successive approximation and stores the conversion result into the ADC result registers (ADRESH:ADRESL register pair). Figure 21-1 shows the block diagram of the ADC.

The ADC voltage reference is software selectable to be either internally generated or externally supplied.

The ADC can generate an interrupt upon completion of a conversion. This interrupt can be used to wake-up the device from Sleep.

**FIGURE 21-1: ADC BLOCK DIAGRAM**



## 21.1 ADC Configuration

When configuring and using the ADC the following functions must be considered:

- Port configuration
- Channel selection
- ADC voltage reference selection
- ADC conversion clock source
- Interrupt control
- Result formatting

### 21.1.1 PORT CONFIGURATION

The ADC can be used to convert both analog and digital signals. When converting analog signals, the I/O pin should be configured for analog by setting the associated TRIS and ANSEL bits. Refer to [Section 11.0 “I/O Ports”](#) for more information.

**Note:** Analog voltages on any pin that is defined as a digital input may cause the input buffer to conduct excess current.

### 21.1.2 CHANNEL SELECTION

There are up to 21 channel selections available on the PIC16(L)F1718 and 32 channel selections on the PIC16(L)F1717/9:

- AN<19:8, 4:0> pins (PIC16(L)F1718)
- AN<27:0> pins (PIC16(L)F1717/9)
- Temperature Indicator
- DAC\_output
- FVR\_buffer1
- FVR\_buffer2

The CHS bits of the ADCON0 register ([Register 21-1](#)) determine which channel is connected to the sample and hold circuit.

When changing channels, a delay is required before starting the next conversion. Refer to [Section 21.2 “ADC Operation”](#) for more information.

### 21.1.3 ADC VOLTAGE REFERENCE

The ADPREF bits of the ADCON1 register provides control of the positive voltage reference. The positive voltage reference can be:

- VREF+ pin
- VDD
- FVR 2.048V
- FVR 4.096V (Not available on LF devices)

The ADNREF bit of the ADCON1 register provides control of the negative voltage reference. The negative voltage reference can be:

- VREF- pin
- VSS

See [Section 21.0 “Analog-to-Digital Converter \(ADC\) Module”](#) for more details on the Fixed Voltage Reference.

### 21.1.4 CONVERSION CLOCK

The source of the conversion clock is software selectable via the ADCS bits of the ADCON1 register. There are seven possible clock options:

- Fosc/2
- Fosc/4
- Fosc/8
- Fosc/16
- Fosc/32
- Fosc/64
- FRC (internal RC oscillator)

The time to complete one bit conversion is defined as TAD. One full 10-bit conversion requires 11.5 TAD periods as shown in [Figure 21-2](#).

For correct conversion, the appropriate TAD specification must be met. Refer to [Table 34-16: ADC Conversion Requirements](#) for more information. [Table 21-1](#) gives examples of appropriate ADC clock selections.

**Note:** Unless using the FRC, any changes in the system clock frequency will change the ADC clock frequency, which may adversely affect the ADC result.

# PIC16(L)F1717/8/9

**TABLE 21-1: ADC CLOCK PERIOD (TAD) vs. DEVICE OPERATING FREQUENCIES**

ADC Clock Period (TAD)		Device Frequency (Fosc)					
ADC Clock Source	ADCS<2:0>	32 MHz	20 MHz	16 MHz	8 MHz	4 MHz	1 MHz
Fosc/2	000	62.5ns <sup>(2)</sup>	100 ns <sup>(2)</sup>	125 ns <sup>(2)</sup>	250 ns <sup>(2)</sup>	500 ns <sup>(2)</sup>	2.0 μs
Fosc/4	100	125 ns <sup>(2)</sup>	200 ns <sup>(2)</sup>	250 ns <sup>(2)</sup>	500 ns <sup>(2)</sup>	1.0 μs	4.0 μs
Fosc/8	001	0.5 μs <sup>(2)</sup>	400 ns <sup>(2)</sup>	0.5 μs <sup>(2)</sup>	1.0 μs	2.0 μs	8.0 μs <sup>(3)</sup>
Fosc/16	101	800 ns	800 ns	1.0 μs	2.0 μs	4.0 μs	16.0 μs <sup>(3)</sup>
Fosc/32	010	1.0 μs	1.6 μs	2.0 μs	4.0 μs	8.0 μs <sup>(3)</sup>	32.0 μs <sup>(2)</sup>
Fosc/64	110	2.0 μs	3.2 μs	4.0 μs	8.0 μs <sup>(3)</sup>	16.0 μs <sup>(2)</sup>	64.0 μs <sup>(2)</sup>
FRC	x11	1.0-6.0 μs <sup>(1,4)</sup>	1.0-6.0 μs <sup>(1,4)</sup>	1.0-6.0 μs <sup>(1,4)</sup>	1.0-6.0 μs <sup>(1,4)</sup>	1.0-6.0 μs <sup>(1,4)</sup>	1.0-6.0 μs <sup>(1,4)</sup>

**Legend:** Shaded cells are outside of recommended range.

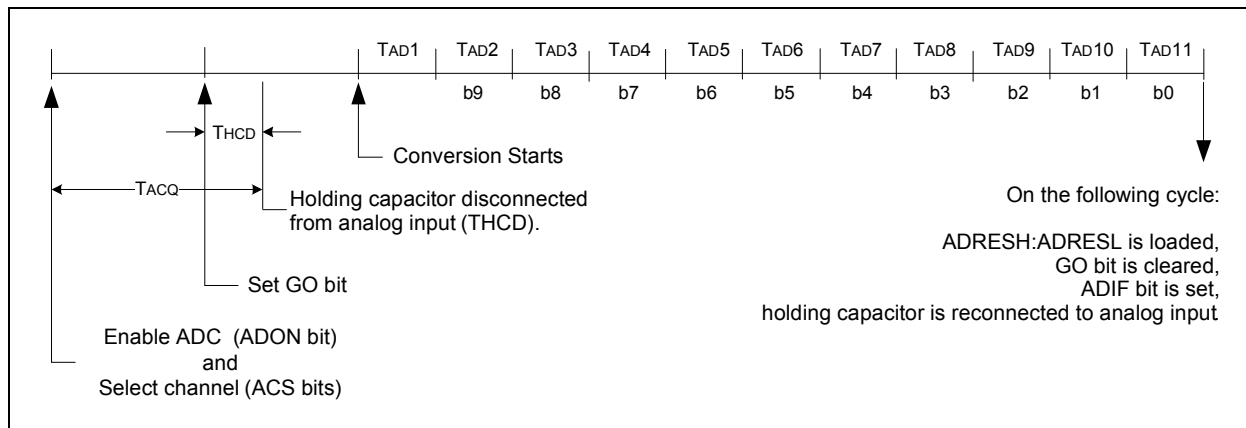
**Note 1:** See TAD parameter for FRC source typical TAD value.

**2:** These values violate the required TAD time.

**3:** Outside the recommended TAD time.

**4:** The ADC clock period (TAD) and total ADC conversion time can be minimized when the ADC clock is derived from the system clock Fosc. However, the FRC oscillator source must be used when conversions are to be performed with the device in Sleep mode.

**FIGURE 21-2: ANALOG-TO-DIGITAL CONVERSION TAD CYCLES**



## 21.1.5 INTERRUPTS

The ADC module allows for the ability to generate an interrupt upon completion of an Analog-to-Digital conversion. The ADC Interrupt Flag is the ADIF bit in the PIR1 register. The ADC Interrupt Enable is the ADIE bit in the PIE1 register. The ADIF bit must be cleared in software.

- Note 1:** The ADIF bit is set at the completion of every conversion, regardless of whether or not the ADC interrupt is enabled.
- 2:** The ADC operates during Sleep only when the FRC oscillator is selected.

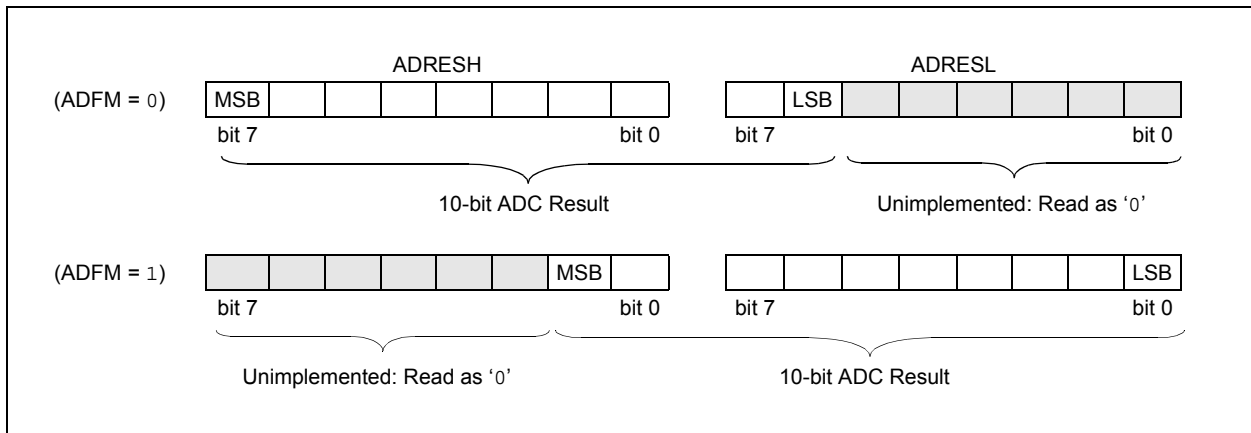
This interrupt can be generated while the device is operating or while in Sleep. If the device is in Sleep, the interrupt will wake-up the device. Upon waking from Sleep, the next instruction following the SLEEP instruction is always executed. If the user is attempting to wake-up from Sleep and resume in-line code execution, the ADIE bit of the PIE1 register and the PEIE bit of the INTCON register must both be set and the GIE bit of the INTCON register must be cleared. If all three of these bits are set, the execution will switch to the Interrupt Service Routine.

## 21.1.6 RESULT FORMATTING

The 10-bit ADC conversion result can be supplied in two formats, left justified or right justified. The ADFM bit of the ADCON1 register controls the output format.

Figure 21-3 shows the two output formats.

**FIGURE 21-3: 10-BIT ADC CONVERSION RESULT FORMAT**



# PIC16(L)F1717/8/9

## 21.2 ADC Operation

### 21.2.1 STARTING A CONVERSION

To enable the ADC module, the ADON bit of the ADCON0 register must be set to a '1'. Setting the GO/DONE bit of the ADCON0 register to a '1' will start the Analog-to-Digital conversion.

**Note:** The GO/DONE bit should not be set in the same instruction that turns on the ADC. Refer to [Section 21.2.6 “ADC Conversion Procedure”](#).

### 21.2.2 COMPLETION OF A CONVERSION

When the conversion is complete, the ADC module will:

- Clear the GO/DONE bit
- Set the ADIF Interrupt Flag bit
- Update the ADRESH and ADRESL registers with new conversion result

### 21.2.3 TERMINATING A CONVERSION

If a conversion must be terminated before completion, the GO/DONE bit can be cleared in software. The ADRESH and ADRESL registers will be updated with the partially complete Analog-to-Digital conversion sample. Incomplete bits will match the last bit converted.

**Note:** A device Reset forces all registers to their Reset state. Thus, the ADC module is turned off and any pending conversion is terminated.

### 21.2.4 ADC OPERATION DURING SLEEP

The ADC module can operate during Sleep. This requires the ADC clock source to be set to the FRC option. When the FRC oscillator source is selected, the ADC waits one additional instruction before starting the conversion. This allows the SLEEP instruction to be executed, which can reduce system noise during the conversion. If the ADC interrupt is enabled, the device will wake-up from Sleep when the conversion completes. If the ADC interrupt is disabled, the ADC module is turned off after the conversion completes, although the ADON bit remains set.

When the ADC clock source is something other than FRC, a SLEEP instruction causes the present conversion to be aborted and the ADC module is turned off, although the ADON bit remains set.

### 21.2.5 AUTO-CONVERSION TRIGGER

The auto-conversion trigger allows periodic ADC measurements without software intervention. When a rising edge of the selected source occurs, the GO/DONE bit is set by hardware.

The auto-conversion trigger source is selected with the TRIGSEL<3:0> bits of the ADCON2 register.

Using the auto-conversion trigger does not assure proper ADC timing. It is the user's responsibility to ensure that the ADC timing requirements are met.

See [Table 21-2](#) for auto-conversion sources.

**TABLE 21-2: AUTO-CONVERSION SOURCES**

Source Peripheral	Signal Name
CCP1	—
CCP2	—
Timer0	T0_overflow
Timer1	T1_overflow
Timer2	T2_match
Timer4	T4_match
Timer6	T6_match
Comparator C1	sync_C1OUT
Comparator C2	sync_C2OUT
CLC1	LC1_out
CLC2	LC2_out
CLC3	LC3_out
CLC4	LC4_out

## 21.2.6 ADC CONVERSION PROCEDURE

This is an example procedure for using the ADC to perform an Analog-to-Digital conversion:

1. Configure Port:
  - Disable pin output driver (Refer to the TRIS register)
  - Configure pin as analog (Refer to the ANSEL register)
  - Disable weak pull-ups either globally (Refer to the OPTION\_REG register) or individually (Refer to the appropriate WPUx register)
2. Configure the ADC module:
  - Select ADC conversion clock
  - Configure voltage reference
  - Select ADC input channel
  - Turn on ADC module
3. Configure ADC interrupt (optional):
  - Clear ADC interrupt flag
  - Enable ADC interrupt
  - Enable peripheral interrupt
  - Enable global interrupt<sup>(1)</sup>
4. Wait the required acquisition time<sup>(2)</sup>.
5. Start conversion by setting the GO/DONE bit.
6. Wait for ADC conversion to complete by one of the following:
  - Polling the GO/DONE bit
  - Waiting for the ADC interrupt (interrupts enabled)
7. Read ADC Result.
8. Clear the ADC interrupt flag (required if interrupt is enabled).

**Note 1:** The global interrupt can be disabled if the user is attempting to wake-up from Sleep and resume in-line code execution.

**2:** Refer to [Section 21.4 “ADC Acquisition Requirements”](#).

## EXAMPLE 21-1: ADC CONVERSION

```

;This code block configures the ADC
;for polling, Vdd and Vss references, FRC
;oscillator and AN0 input.
;
;Conversion start & polling for completion
; are included.
;
BANKSEL    ADCON1    ;
MOVLW     B'11110000' ;Right justify, FRC
                                ;oscillator
MOVWF     ADCON1    ;Vdd and Vss Vref
BANKSEL    TRISA    ;
BSF       TRISA,0    ;Set RA0 to input
BANKSEL    ANSEL    ;
BSF       ANSEL,0    ;Set RA0 to analog
BANKSEL    WPUA    ;
BCF       WPUA,0    ;Disable weak
                                ;pull-up on RA0

BANKSEL    ADCON0    ;
MOVLW     B'00000001' ;Select channel AN0
MOVWF     ADCON0    ;Turn ADC On
CALL     SampleTime ;Acquisiton delay
BSF      ADCON0,ADGO ;Start conversion
BTFSC    ADCON0,ADGO ;Is conversion done?
GOTO     $-1        ;No, test again
BANKSEL    ADRESH    ;
MOVF     ADRESH,W    ;Read upper 2 bits
MOVWF    RESULTHI    ;store in GPR space
BANKSEL    ADRESL    ;
MOVF     ADRESL,W    ;Read lower 8 bits
MOVWF    RESULTLO    ;Store in GPR space
    
```

# PIC16(L)F1717/8/9

## 21.3 Register Definitions: ADC Control

### REGISTER 21-1: ADON0: ADC CONTROL REGISTER 0

U-0	R/W-0/0	R/W-0/0	R/W-0/0	R/W-0/0	R/W-0/0	R/W-0/0	R/W-0/0
—	CHS<4:0>					GO/DONE	ADON
bit 7							bit 0

#### Legend:

R = Readable bit	W = Writable bit	U = Unimplemented bit, read as '0'
u = Bit is unchanged	x = Bit is unknown	-n/n = Value at POR and BOR/Value at all other Resets
'1' = Bit is set	'0' = Bit is cleared	

bit 7 **Unimplemented:** Read as '0'

bit 6-2 **CHS<4:0>:** Analog Channel Select bits

- 11111 = FVR (Fixed Voltage Reference) Buffer 1 Output<sup>(2)</sup>
- 11110 = DAC1\_output<sup>(1)</sup>
- 11101 = Temperature Indicator<sup>(3)</sup>
- 11100 = DAC2\_output<sup>(5)</sup>
- 11011 = AN27<sup>(4)</sup>
- 11010 = AN26<sup>(4)</sup>
- 11001 = AN25<sup>(4)</sup>
- 11000 = AN24<sup>(4)</sup>
- 10111 = AN23<sup>(4)</sup>
- 10110 = AN22<sup>(4)</sup>
- 10101 = AN21<sup>(4)</sup>
- 10100 = AN20<sup>(4)</sup>
- 10011 = AN19
- 10010 = AN18
- 10001 = AN17
- 10000 = AN16
- 01111 = AN15
- 01110 = AN14
- 01101 = AN13
- 01100 = AN12
- 01011 = AN11
- 01010 = AN10
- 01001 = AN9
- 01000 = AN8
- 00111 = AN7<sup>(4)</sup>
- 00110 = AN6<sup>(4)</sup>
- 00101 = AN5<sup>(4)</sup>
- 00100 = AN4
- 00011 = AN3
- 00010 = AN2
- 00001 = AN1
- 00000 = AN0

bit 1 **GO/DONE:** ADC Conversion Status bit

- 1 = ADC conversion cycle in progress. Setting this bit starts an ADC conversion cycle. This bit is automatically cleared by hardware when the ADC conversion has completed.
- 0 = ADC conversion completed/not in progress

bit 0 **ADON:** ADC Enable bit

- 1 = ADC is enabled
- 0 = ADC is disabled and consumes no operating current

- Note**
- 1: See [Section 23.0 “8-Bit Digital-to-Analog Converter \(DAC1\) Module”](#) for more information.
  - 2: See [Section 14.0 “Fixed Voltage Reference \(FVR\)”](#) for more information.
  - 3: See [Section 15.0 “Temperature Indicator Module”](#) for more information.
  - 4: PIC16(L)F1717/9 only.
  - 5: See [Section 24.0 “5-Bit Digital-to-Analog Converter \(DAC2\) Module”](#) for more information.



## REGISTER 21-2: ADCON1: ADC CONTROL REGISTER 1

R/W-0/0	R/W-0/0	R/W-0/0	R/W-0/0	U-0	R/W-0/0	R/W-0/0	R/W-0/0	
ADFM	ADCS<2:0>		—		ADNREF	ADPREF<1:0>		
bit 7								bit 0

### Legend:

R = Readable bit	W = Writable bit	U = Unimplemented bit, read as '0'
u = Bit is unchanged	x = Bit is unknown	-n/n = Value at POR and BOR/Value at all other Resets
'1' = Bit is set	'0' = Bit is cleared	

- bit 7      **ADFM:** ADC Result Format Select bit  
 1 = Right justified. Six Most Significant bits of ADRESH are set to '0' when the conversion result is loaded.  
 0 = Left justified. Six Least Significant bits of ADRESL are set to '0' when the conversion result is loaded.
- bit 6-4    **ADCS<2:0>:** ADC Conversion Clock Select bits  
 111 = FRC (clock supplied from an internal RC oscillator)  
 110 = FOSC/64  
 101 = FOSC/16  
 100 = FOSC/4  
 011 = FRC (clock supplied from an internal RC oscillator)  
 010 = FOSC/32  
 001 = FOSC/8  
 000 = FOSC/2
- bit 3      **Unimplemented:** Read as '0'
- bit 2      **ADNREF:** A/D Negative Voltage Reference Configuration bit  
 1 = VREF- is connected to VREF- pin  
 0 = VREF- is connected to VSS
- bit 1-0    **ADPREF<1:0>:** ADC Positive Voltage Reference Configuration bits  
 11 = VREF+ is connected to internal Fixed Voltage Reference (FVR) module<sup>(1)</sup>  
 10 = VREF+ is connected to external VREF+ pin<sup>(1)</sup>  
 01 = Reserved  
 00 = VREF+ is connected to VDD

**Note 1:** When selecting the VREF+ pin as the source of the positive reference, be aware that a minimum voltage specification exists. See [Table 34-16: ADC Conversion Requirements](#) for details.

# PIC16(L)F1717/8/9

## REGISTER 21-3: ADCON2: ADC CONTROL REGISTER 2

R/W-0/0	R/W-0/0	R/W-0/0	R/W-0/0	U-0	U-0	U-0	U-0
TRIGSEL<3:0> <sup>(1)</sup>				—	—	—	—
bit 7				bit 0			

### Legend:

R = Readable bit	W = Writable bit	U = Unimplemented bit, read as '0'
u = Bit is unchanged	x = Bit is unknown	-n/n = Value at POR and BOR/Value at all other Resets
'1' = Bit is set	'0' = Bit is cleared	

bit 7-4 **TRIGSEL<3:0>**: Auto-Conversion Trigger Selection bits<sup>(1)</sup>

0000	= No auto-conversion trigger selected
0001	= CCP1
0010	= CCP2
0011	= Timer0 – T0_overflow <sup>(2)</sup>
0100	= Timer1 – T1_overflow <sup>(2)</sup>
0101	= Timer2 – T2_match
0110	= Comparator C1 – sync_C1OUT
0111	= Comparator C2 – sync_C2OUT
1000	= CLC1 – LC1_out
1001	= CLC2 – LC2_out
1010	= CLC3 – LC3_out
1011	= CLC4 – LC4_out
1100	= Timer4 – T4_match
1101	= Timer6 – T6_match
1110	= Reserved
1111	= Reserved

bit 3-0 **Unimplemented**: Read as '0'

**Note 1:** This is a rising edge sensitive input for all sources.

**2:** Signal also sets its corresponding interrupt flag.

## REGISTER 21-4: ADRESH: ADC RESULT REGISTER HIGH (ADRESH) ADFM = 0

R/W-x/u	R/W-x/u	R/W-x/u	R/W-x/u	R/W-x/u	R/W-x/u	R/W-x/u	R/W-x/u
ADRES<9:2>							
bit 7				bit 0			

### Legend:

R = Readable bit	W = Writable bit	U = Unimplemented bit, read as '0'
u = Bit is unchanged	x = Bit is unknown	-n/n = Value at POR and BOR/Value at all other Resets
'1' = Bit is set	'0' = Bit is cleared	

bit 7-0 **ADRES<9:2>**: ADC Result Register bits  
Upper eight bits of 10-bit conversion result

# PIC16(L)F1717/8/9

## REGISTER 21-5: ADRESL: ADC RESULT REGISTER LOW (ADRESL) ADFM = 0

R/W-x/u	R/W-x/u	R/W-x/u	R/W-x/u	R/W-x/u	R/W-x/u	R/W-x/u	R/W-x/u
ADRES<1:0>							
bit 7							bit 0

### Legend:

R = Readable bit                      W = Writable bit                      U = Unimplemented bit, read as '0'  
u = Bit is unchanged                      x = Bit is unknown                      -n/n = Value at POR and BOR/Value at all other Resets  
'1' = Bit is set                              '0' = Bit is cleared

bit 7-6                      **ADRES<1:0>**: ADC Result Register bits  
Lower two bits of 10-bit conversion result

bit 5-0                      **Reserved**: Do not use.

## REGISTER 21-6: ADRESH: ADC RESULT REGISTER HIGH (ADRESH) ADFM = 1

R/W-x/u	R/W-x/u	R/W-x/u	R/W-x/u	R/W-x/u	R/W-x/u	R/W-x/u	R/W-x/u
—						ADRES<9:8>	
bit 7							bit 0

### Legend:

R = Readable bit                      W = Writable bit                      U = Unimplemented bit, read as '0'  
u = Bit is unchanged                      x = Bit is unknown                      -n/n = Value at POR and BOR/Value at all other Resets  
'1' = Bit is set                              '0' = Bit is cleared

bit 7-2                      **Reserved**: Do not use.

bit 1-0                      **ADRES<9:8>**: ADC Result Register bits  
Upper two bits of 10-bit conversion result

## REGISTER 21-7: ADRESL: ADC RESULT REGISTER LOW (ADRESL) ADFM = 1

R/W-x/u	R/W-x/u	R/W-x/u	R/W-x/u	R/W-x/u	R/W-x/u	R/W-x/u	R/W-x/u
ADRES<7:0>							
bit 7							bit 0

### Legend:

R = Readable bit                      W = Writable bit                      U = Unimplemented bit, read as '0'  
u = Bit is unchanged                      x = Bit is unknown                      -n/n = Value at POR and BOR/Value at all other Resets  
'1' = Bit is set                              '0' = Bit is cleared

bit 7-0                      **ADRES<7:0>**: ADC Result Register bits  
Lower eight bits of 10-bit conversion result

# PIC16(L)F1717/8/9

## 21.4 ADC Acquisition Requirements

For the ADC to meet its specified accuracy, the charge holding capacitor (CHOLD) must be allowed to fully charge to the input channel voltage level. The Analog Input model is shown in Figure 21-4. The source impedance (RS) and the internal sampling switch (RSS) impedance directly affect the time required to charge the capacitor CHOLD. The sampling switch (RSS) impedance varies over the device voltage (VDD), refer to Figure 21-4. **The maximum recommended impedance for analog sources is 10 kΩ.** As the

source impedance is decreased, the acquisition time may be decreased. After the analog input channel is selected (or changed), an ADC acquisition must be done before the conversion can be started. To calculate the minimum acquisition time, Equation 21-1 may be used. This equation assumes that 1/2 LSB error is used (1,024 steps for the ADC). The 1/2 LSB error is the maximum error allowed for the ADC to meet its specified resolution.

### EQUATION 21-1: ACQUISITION TIME EXAMPLE

*Assumptions: Temperature = 50°C and external impedance of 10kΩ 5.0V VDD*

$$\begin{aligned}T_{ACQ} &= \text{Amplifier Settling Time} + \text{Hold Capacitor Charging Time} + \text{Temperature Coefficient} \\ &= T_{AMP} + T_C + T_{COFF} \\ &= 2\mu s + T_C + [(Temperature - 25^\circ C)(0.05\mu s/^\circ C)]\end{aligned}$$

*The value for TC can be approximated with the following equations:*

$$V_{APPLIED} \left( 1 - \frac{1}{(2^n + 1) - 1} \right) = V_{CHOLD} \quad ;[1] \text{ } V_{CHOLD} \text{ charged to within } 1/2 \text{ lsb}$$

$$V_{APPLIED} \left( 1 - e^{-\frac{TC}{RC}} \right) = V_{CHOLD} \quad ;[2] \text{ } V_{CHOLD} \text{ charge response to } V_{APPLIED}$$

$$V_{APPLIED} \left( 1 - e^{-\frac{TC}{RC}} \right) = V_{APPLIED} \left( 1 - \frac{1}{(2^n + 1) - 1} \right) \quad ;\text{combining [1] and [2]}$$

*Note: Where n = number of bits of the ADC.*

*Solving for TC:*

$$\begin{aligned}T_C &= -CHOLD(R_{IC} + R_{SS} + R_S) \ln(1/2047) \\ &= -10pF(1k\Omega + 7k\Omega + 10k\Omega) \ln(0.0004885) \\ &= 1.37\mu s\end{aligned}$$

*Therefore:*

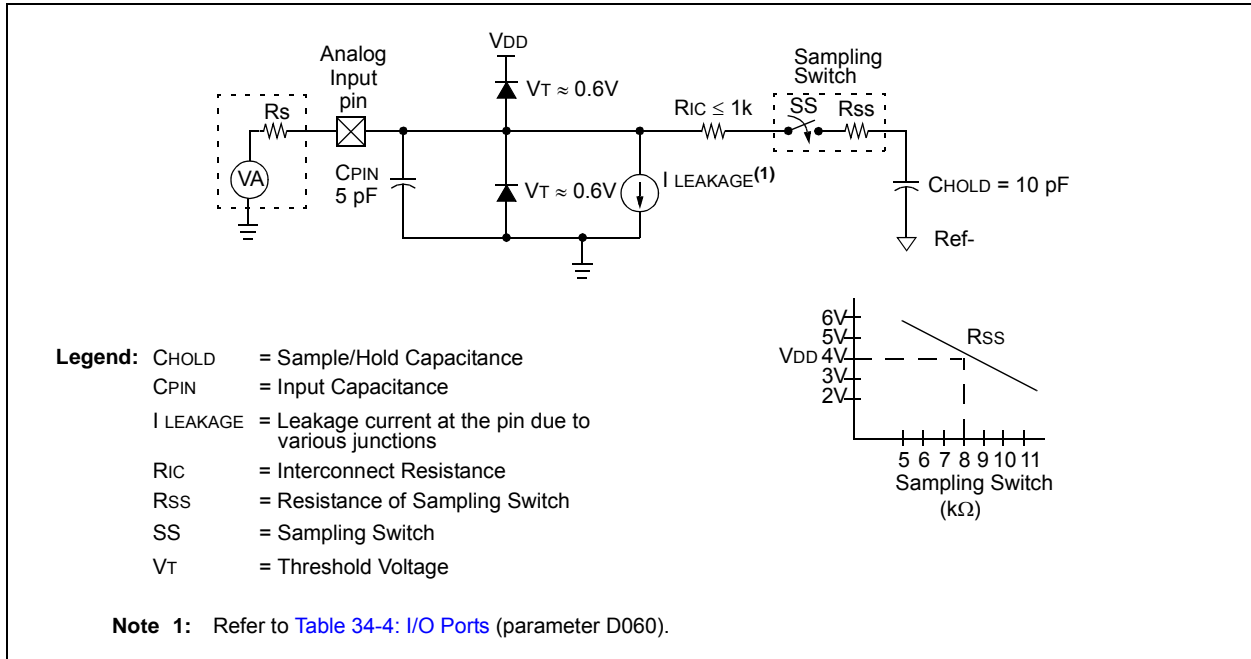
$$\begin{aligned}T_{ACQ} &= 2\mu s + 892ns + [(50^\circ C - 25^\circ C)(0.05\mu s/^\circ C)] \\ &= 4.62\mu s\end{aligned}$$

**Note 1:** The reference voltage (VREF) has no effect on the equation, since it cancels itself out.

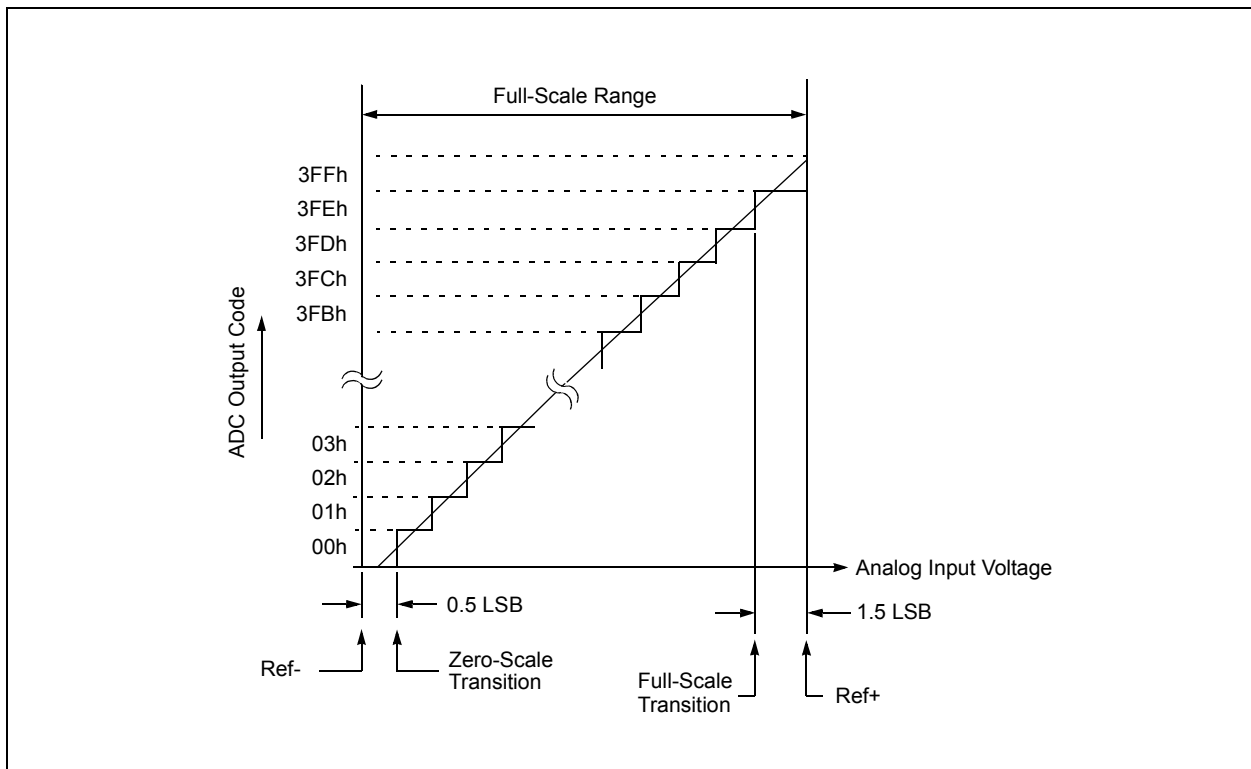
**2:** The charge holding capacitor (CHOLD) is not discharged after each conversion.

**3:** The maximum recommended impedance for analog sources is 10 kΩ. This is required to meet the pin leakage specification.

**FIGURE 21-4: ANALOG INPUT MODEL**



**FIGURE 21-5: ADC TRANSFER FUNCTION**



# PIC16(L)F1717/8/9

**TABLE 21-3: SUMMARY OF REGISTERS ASSOCIATED WITH ADC**

Name	Bit 7	Bit 6	Bit 5	Bit 4	Bit 3	Bit 2	Bit 1	Bit 0	Register on Page
ADCON0	—	CHS<4:0>					GO/DONE	ADON	248
ADCON1	ADFM	ADCS<2:0>			—	ADNREF	ADPREF<1:0>		249
ADCON2	TRIGSEL<3:0>				—	—	—	—	250
ADRESH	ADC Result Register High								251
ADRESL	ADC Result Register Low								251
ANSELA	—	—	ANSA5	ANSA4	ANSA3	ANSA2	ANSA1	ANSA0	125
ANSELB	—	—	ANSB5	ANSB4	ANSB3	ANSB2	ANSB1	ANSB0	131
ANSELC	ANSC7	ANSC6	ANSC5	ANSC4	ANSC3	ANSC2			136
ANSELD <sup>(1)</sup>	ANS7	ANS6	ANS5	ANS4	ANS3	ANS2	ANS1	ANS0	141
ANSELE <sup>(1)</sup>	—	—	—	—	—	ANSE2	ANSE1	ANSE0	146
INTCON	GIE	PEIE	TMR0IE	INTE	IOCIE	TMR0IF	INTF	IOCF	90
PIE1	TMR1GIE	ADIE	RCIE	TXIE	SSP1IE	CCP1IE	TMR2IE	TMR1IE	91
PIR1	TMR1GIF	ADIF	RCIF	TXIF	SSP1IF	CCP1IF	TMR2IF	TMR1IF	94
TRISA	TRISA7	TRISA6	TRISA5	TRISA4	TRISA3	TRISA2	TRISA1	TRISA0	124
TRISB	TRISB7	TRISB6	TRISB5	TRISB4	TRISB3	TRISB2	TRISB1	TRISB0	130
TRISC	TRISC7	TRISC6	TRISC5	TRISC4	TRISC3	TRISC2	TRISC1	TRISC0	135
TRISD <sup>(1)</sup>	TRISD7	TRISD6	TRISD5	TRISD4	TRISD3	TRISD2	TRISD1	TRISD0	140
TRISE	—	—	—	—	TRISE3	TRISE2 <sup>(1)</sup>	TRISE1 <sup>(1)</sup>	TRISE0 <sup>(1)</sup>	145
FVRCON	FVREN	FVRRDY	TSEN	TSRNG	CDAFVR<1:0>		ADFVR<1:0>		165
DAC1CON0	DAC1EN	—	DAC1OE1	DAC1OE2	DAC1PSS<1:0>		—	DAC1NSS	260

**Legend:** x = unknown, u = unchanged, — = unimplemented read as '0', α = value depends on condition. Shaded cells are not used for the ADC module.

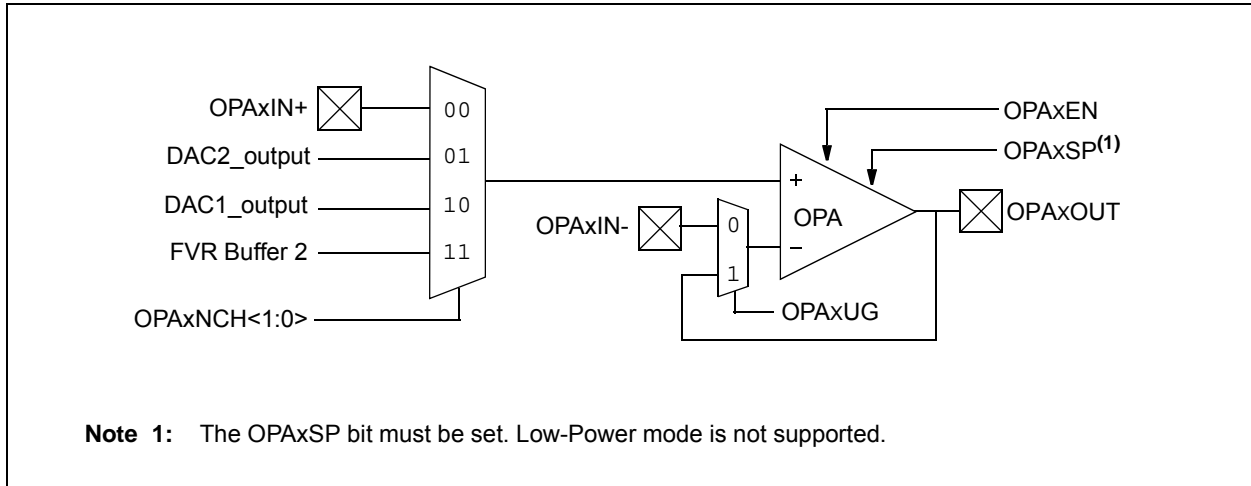
**Note 1:** PIC16(L)F1717/9 only.

## 22.0 OPERATIONAL AMPLIFIER (OPA) MODULES

The Operational Amplifier (OPA) is a standard three-terminal device requiring external feedback to operate. The OPA module has the following features:

- External connections to I/O ports
- Low leakage inputs
- Factory Calibrated Input Offset Voltage

**FIGURE 22-1: OPAX MODULE BLOCK DIAGRAM**



# PIC16(L)F1717/8/9

---

## 22.1 OPA Module Performance

Common AC and DC performance specifications for the OPA module:

- Common Mode Voltage Range
- Leakage Current
- Input Offset Voltage
- Open Loop Gain
- Gain Bandwidth Product

**Common mode voltage range** is the specified voltage range for the OPA+ and OPA- inputs, for which the OPA module will perform to within its specifications. The OPA module is designed to operate with input voltages between  $V_{SS}$  and  $V_{DD}$ . Behavior for Common mode voltages greater than  $V_{DD}$ , or below  $V_{SS}$ , are not guaranteed.

**Leakage current** is a measure of the small source or sink currents on the OPA+ and OPA- inputs. To minimize the effect of leakage currents, the effective impedances connected to the OPA+ and OPA- inputs should be kept as small as possible and equal.

**Input offset voltage** is a measure of the voltage difference between the OPA+ and OPA- inputs in a closed loop circuit with the OPA in its linear region. The offset voltage will appear as a DC offset in the output equal to the input offset voltage, multiplied by the gain of the circuit. The input offset voltage is also affected by the Common mode voltage. The OPA is factory calibrated to minimize the input offset voltage of the module.

**Open loop gain** is the ratio of the output voltage to the differential input voltage, (OPA+) - (OPA-). The gain is greatest at DC and falls off with frequency.

**Gain Bandwidth Product** or GBWP is the frequency at which the open loop gain falls off to 0 dB.

### 22.1.1 OPA Module Control

The OPA module is enabled by setting the OPAXEN bit of the OPAXCON register. When enabled, the OPA forces the output driver of OPAXOUT pin into tri-state to prevent contention between the driver and the OPA output.

<b>Note:</b> When the OPA module is enabled, the OPAXOUT pin is driven by the op amp output, not by the PORT digital driver. Refer to <a href="#">Table 34-17: Operational Amplifier (OPA)</a> for the op amp output drive capability.
--

### 22.1.2 UNITY GAIN MODE

The OPAXUG bit of the OPAXCON register selects the Unity Gain mode. When unity gain is selected, the OPA output is connected to the inverting input and the OPAXIN pin is relinquished, releasing the pin for general purpose input and output.

## 22.2 Effects of Reset

A device Reset forces all registers to their Reset state. This disables the OPA module.



## 22.3 Register Definitions: Op Amp Control

**REGISTER 22-1: OPAXCON: OPERATIONAL AMPLIFIERS (OPAx) CONTROL REGISTERS**

R/W-0/0	R/W-0/0	U-0	R/W-0/0	U-0	U-0	R/W-0/0	R/W-0/0
OPAxEN	OPAxSP	—	OPAxUG	—	—	OPAxCH<1:0>	
bit 7						bit 0	

**Legend:**

R = Readable bit	W = Writable bit	U = Unimplemented bit, read as '0'
u = Bit is unchanged	x = Bit is unknown	-n/n = Value at POR and BOR/Value at all other Resets
'1' = Bit is set	'0' = Bit is cleared	q = Value depends on condition

- bit 7      **OPAxEN:** Op Amp Enable bit  
1 = Op amp is enabled  
0 = Op amp is disabled and consumes no active power
- bit 6      **OPAxSP:** Op Amp Speed/Power Select bit  
1 = Op amp operates in high GBWP mode  
0 = Reserved. Do not use.
- bit 5      **Unimplemented:** Read as '0'
- bit 4      **OPAxUG:** Op Amp Unity Gain Select bit  
1 = OPA output is connected to inverting input. OPAXIN- pin is available for general purpose I/O.  
0 = Inverting input is connected to the OPAXIN- pin
- bit 3-2    **Unimplemented:** Read as '0'
- bit 1-0    **OPAxCH<1:0>:** Non-inverting Channel Selection bits  
11 = Non-inverting input connects to FVR Butter 2 output  
10 = Non-inverting input connects to DAC1\_output  
01 = Non-inverting input connects to DAC2\_output  
00 = Non-inverting input connects to OPAXIN+ pin

**TABLE 22-1: SUMMARY OF REGISTERS ASSOCIATED WITH OP AMPS**

Name	Bit 7	Bit 6	Bit 5	Bit 4	Bit 3	Bit 2	Bit 1	Bit 0	Register on Page
ANSELA	—	—	ANSA5	ANSA4	ANSA3	ANSA2	ANSA1	ANSA0	125
ANSELB	—	—	ANSB5	ANSB4	ANSB3	ANSB2	ANSB1	ANSB0	131
DAC1CON0	DAC1EN	—	DAC1OE1	DAC1OE2	DAC1PSS<1:0>		—	DAC1NSS	260
DAC1CON1	DAC1R<7:0>								260
FVRCON	FVREN	FVRRDY	TSEN	TSRNG	CDAFVR<1:0>		ADFVR<1:0>		165
OPA1CON	OPA1EN	OPA1SP	—	OPA1UG	—	—	OPA1PCH<1:0>		257
OPA2CON	OPA2EN	OPA2SP	—	OPA2UG	—	—	OPA2PCH<1:0>		257
TRISA	TRISB7	TRISB6	TRISB5	TRISB4	TRISB3	TRISB2	TRISB1	TRISB0	124
TRISB	TRISC7	TRISC6	TRISC5	TRISC4	TRISC3	TRISC2	TRISC1	TRISC0	130

**Legend:** — = unimplemented location, read as '0'. Shaded cells are not used by op amps.

# PIC16(L)F1717/8/9

## 23.0 8-BIT DIGITAL-TO-ANALOG CONVERTER (DAC1) MODULE

The Digital-to-Analog Converter supplies a variable voltage reference, ratiometric with the input source, with 256 selectable output levels.

The input of the DAC can be connected to:

- External VREF pins
- VDD supply voltage
- FVR (Fixed Voltage Reference)

The output of the DAC can be configured to supply a reference voltage to the following:

- Comparator positive input
- ADC input channel
- DAC1OUT1 pin
- DAC1OUT2 pin

The Digital-to-Analog Converter (DAC) is enabled by setting the DAC1EN bit of the DAC1CON0 register.

### 23.1 Output Voltage Selection

The DAC has 256 voltage level ranges. The 256 levels are set with the DAC1R<7:0> bits of the DAC1CON1 register.

The DAC output voltage is determined by [Equation 23-1](#):

#### EQUATION 23-1: DAC OUTPUT VOLTAGE

$$\begin{aligned} & \text{IF DAC1EN} = 1 \\ V_{OUT} &= \left( (V_{SOURCE+} - V_{SOURCE-}) \times \frac{DAC1R[7:0]}{2^8} \right) + V_{SOURCE-} \\ V_{SOURCE+} &= V_{DD}, V_{REF}, \text{ or FVR BUFFER 2} \\ V_{SOURCE-} &= V_{SS} \end{aligned}$$

### 23.2 Ratiometric Output Level

The DAC output value is derived using a resistor ladder with each end of the ladder tied to a positive and negative voltage reference input source. If the voltage of either input source fluctuates, a similar fluctuation will result in the DAC output value.

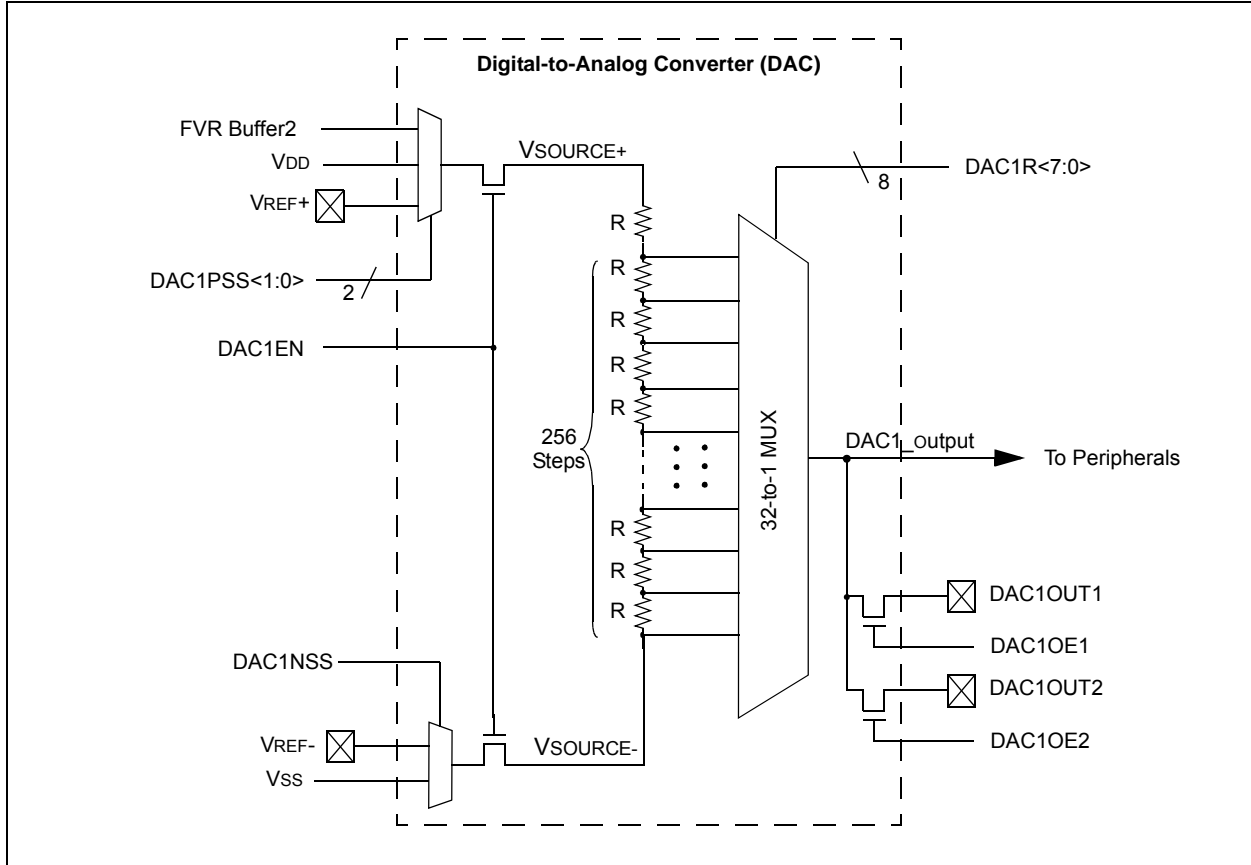
The value of the individual resistors within the ladder can be found in [Table 34-19: 8-Bit Digital-to-Analog Converter \(DAC\) Specifications](#).

### 23.3 DAC Voltage Reference Output

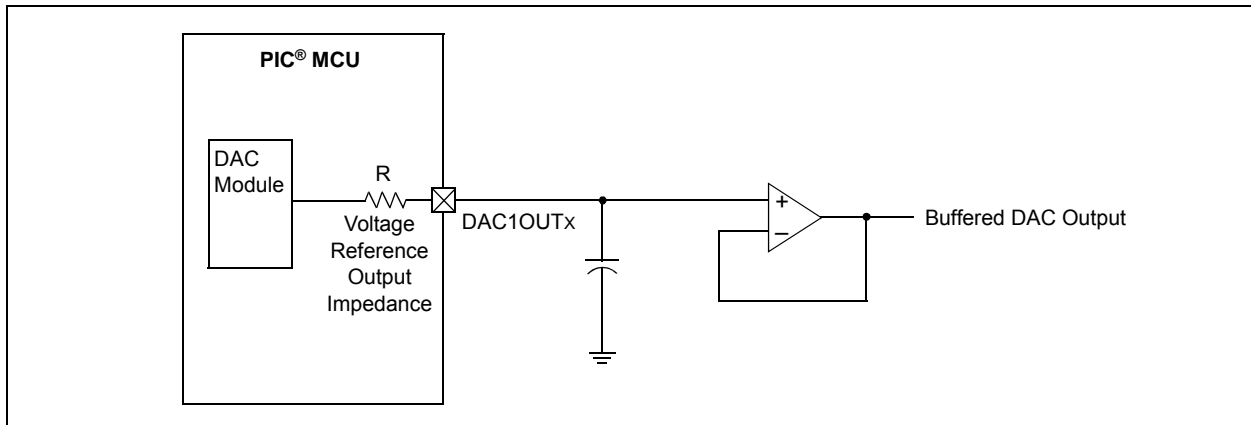
The DAC voltage can be output to the DAC1OUT1 and DAC1OUT2 pins by setting the respective DAC1OE1 and DAC1OE2 pins of the DAC1CON0 register. Selecting the DAC reference voltage for output on either DAC1OUTx pin automatically overrides the digital output buffer and digital input threshold detector functions of that pin. Reading the DAC1OUTx pin when it has been configured for DAC reference voltage output will always return a '0'.

Due to the limited current drive capability, a buffer must be used on the DAC voltage reference output for external connections to either DAC1OUTx pin. [Figure 23-2](#) shows an example buffering technique.

**FIGURE 23-1: DIGITAL-TO-ANALOG CONVERTER BLOCK DIAGRAM**



**FIGURE 23-2: VOLTAGE REFERENCE OUTPUT BUFFER EXAMPLE**



## 23.4 Operation During Sleep

The DAC continues to function during Sleep. When the device wakes up from Sleep through an interrupt or a Watchdog Timer time-out, the contents of the DAC1CON0 register are not affected. To minimize current consumption in Sleep mode, the voltage reference should be disabled.

## 23.5 Effects of a Reset

A device Reset affects the following:

- DAC is disabled
- DAC output voltage is removed from the DAC1OUT pin
- The DAC1R<7:0> range select bits are cleared

# PIC16(L)F1717/8/9

## 23.6 Register Definitions: DAC Control

### REGISTER 23-1: DAC1CON0: DAC1 CONTROL REGISTER 0

R/W-0/0	U-0	R/W-0/0	R/W-0/0	R/W-0/0	R/W-0/0	U-0	R/W-0/0
DAC1EN	—	DAC1OE1	DAC1OE2	DAC1PSS<1:0>		—	DAC1NSS
bit 7							bit 0

#### Legend:

R = Readable bit                      W = Writable bit                      U = Unimplemented bit, read as '0'  
u = Bit is unchanged                      x = Bit is unknown                      -n/n = Value at POR and BOR/Value at all other Resets  
'1' = Bit is set                              '0' = Bit is cleared

- bit 7            **DAC1EN:** DAC1 Enable bit  
1 = DAC is enabled  
0 = DAC is disabled
- bit 6            **Unimplemented:** Read as '0'
- bit 5            **DAC1OE1:** DAC1 Voltage Output 1 Enable bit  
1 = DAC voltage level is also an output on the DAC1OUT1 pin  
0 = DAC voltage level is disconnected from the DAC1OUT1 pin
- bit 4            **DAC1OE2:** DAC1 Voltage Output 2 Enable bit  
1 = DAC voltage level is also an output on the DAC1OUT2 pin  
0 = DAC voltage level is disconnected from the DAC1OUT2 pin
- bit 3-2         **DAC1PSS<1:0>:** DAC1 Positive Source Select bits  
11 = Reserved, do not use  
10 = FVR Buffer2 output  
01 = VREF+ pin  
00 = VDD
- bit 1            **Unimplemented:** Read as '0'
- bit 0            **DAC1NSS:** DAC1 Negative Source Select bits  
1 = VREF- pin  
0 = VSS

### REGISTER 23-2: DAC1CON1: DAC1 CONTROL REGISTER 1

R/W-0/0	R/W-0/0	R/W-0/0	R/W-0/0	R/W-0/0	R/W-0/0	R/W-0/0	R/W-0/0
DAC1R<7:0>							
bit 7							bit 0

#### Legend:

R = Readable bit                      W = Writable bit                      U = Unimplemented bit, read as '0'  
u = Bit is unchanged                      x = Bit is unknown                      -n/n = Value at POR and BOR/Value at all other Resets  
'1' = Bit is set                              '0' = Bit is cleared

- bit 7-0         **DAC1R<7:0>:** DAC1 Voltage Output Select bits

### TABLE 23-1: SUMMARY OF REGISTERS ASSOCIATED WITH THE DAC1 MODULE

Name	Bit 7	Bit 6	Bit 5	Bit 4	Bit 3	Bit 2	Bit 1	Bit 0	Register on page
DAC1CON0	DAC1EN	—	DAC1OE1	DAC1OE2	DAC1PSS<1:0>		—	DAC1NSS	260
DAC1CON1	DAC1R<7:0>								260

**Legend:** — = Unimplemented location, read as '0'. Shaded cells are not used with the DAC module.

## 24.0 5-BIT DIGITAL-TO-ANALOG CONVERTER (DAC2) MODULE

The Digital-to-Analog Converter supplies a variable voltage reference, ratiometric with the input source, with 32 selectable output levels.

The input of the DAC can be connected to:

- External VREF pins
- VDD supply voltage
- FVR (Fixed Voltage Reference)

The output of the DAC can be configured to supply a reference voltage to the following:

- Comparator positive input
- ADC input channel
- DAC2OUT1/DAC2OUT2 pin
- Comparators
- Op Amps

The Digital-to-Analog Converter (DAC) can be enabled by setting the DAC2EN bit of the DAC2CON0 register.

## 24.1 Output Voltage Selection

The DAC has 32 voltage level ranges. The 32 levels are set with the DAC2R<4:0> bits of the DAC2CON1 register.

The DAC output voltage is determined by the following equations:

### EQUATION 24-1: DAC OUTPUT VOLTAGE

**IF DACEN = 1**

$$V_{OUT} = \left( (V_{SOURCE+} - V_{SOURCE-}) \times \frac{DACR[4:0]}{2^5} \right) + V_{SOURCE-}$$

**IF DACEN = 0 and DACLPS = 1 and DACR[4:0] = 11111**

$$V_{OUT} = V_{SOURCE+}$$

**IF DACEN = 0 and DACLPS = 0 and DACR[4:0] = 00000**

$$V_{OUT} = V_{SOURCE-}$$

$V_{SOURCE+} = V_{DD}, V_{REF}, \text{ or } FVR \text{ BUFFER } 2$

$V_{SOURCE-} = V_{SS}$

## 24.2 Ratiometric Output Level

The DAC output value is derived using a resistor ladder with each end of the ladder tied to a positive and negative voltage reference input source. If the voltage of either input source fluctuates, a similar fluctuation will result in the DAC output value.

The value of the individual resistors within the ladder can be found in [Table 34-20: 5-Bit Digital-to-Analog Converter \(DAC\) Specifications](#).

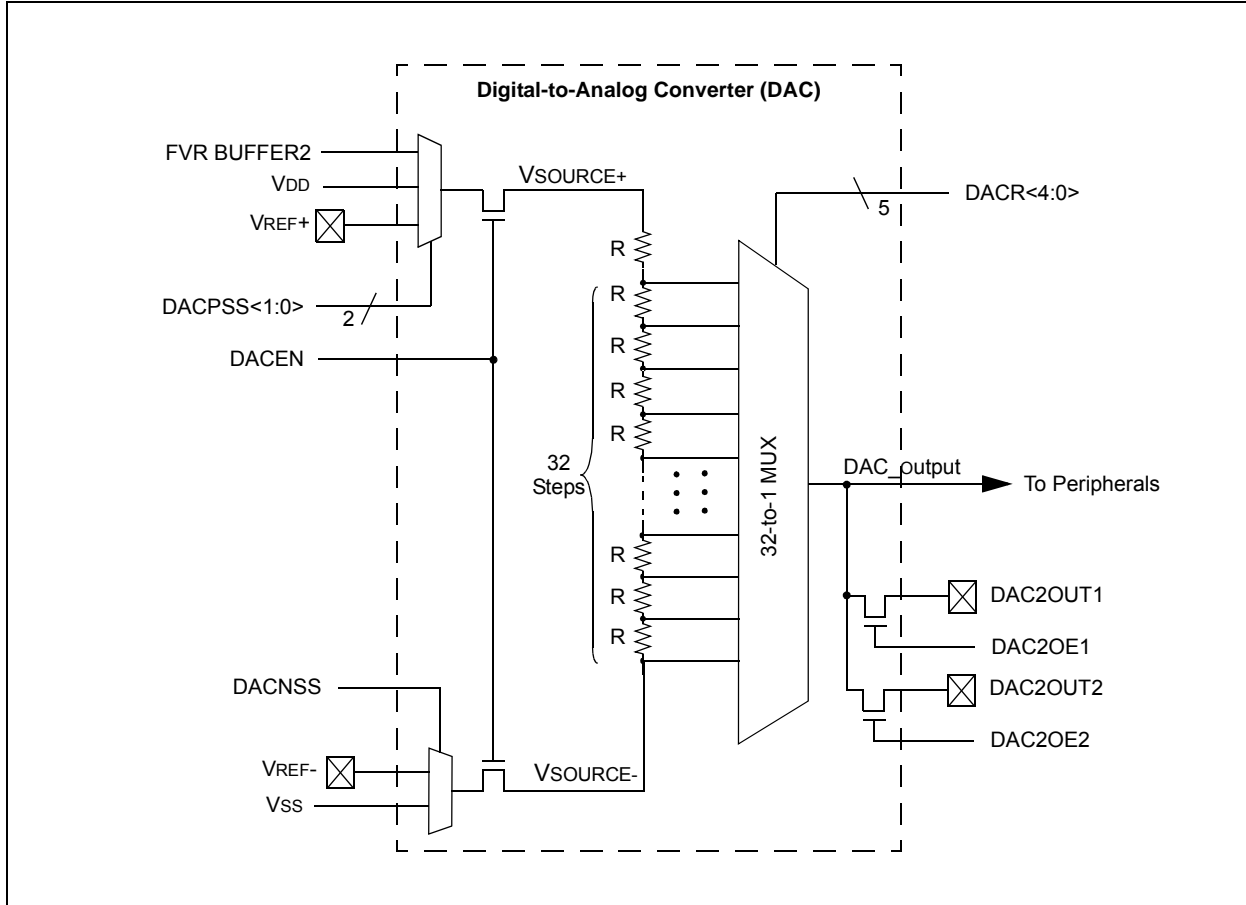
## 24.3 DAC Voltage Reference Output

The DAC can be output to the DAC2OUT1 and DAC2OUT2 pins by setting the DAC2OE1 and DAC2OE2 bits of the DAC2CON0 register to '1'. Selecting the DAC reference voltage for output on the DACOUTx pin automatically overrides the digital output buffer and digital input threshold detector functions of that pin. Reading the DAC2OUTx pin when it has been configured for DAC reference voltage output will always return a '0'.

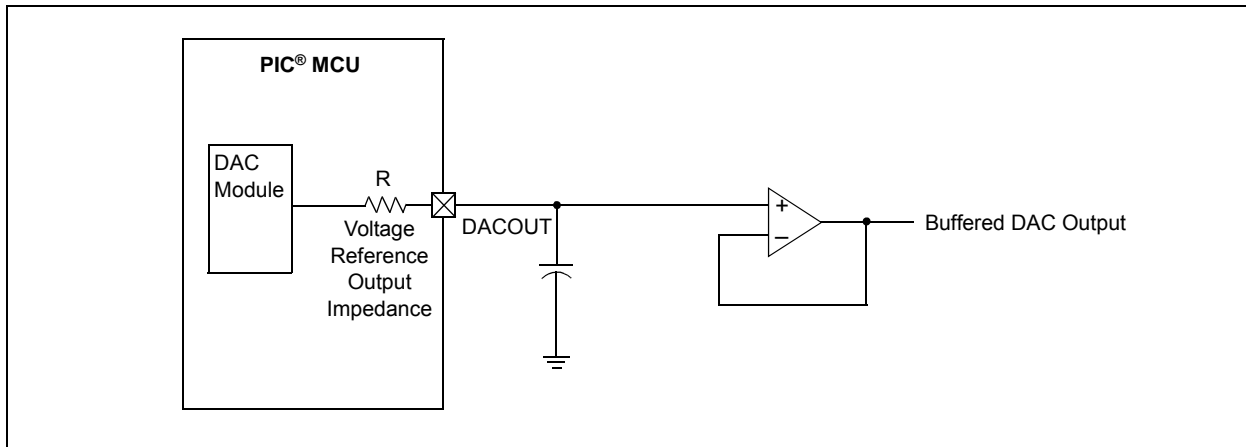
Due to the limited current drive capability, a buffer must be used on the DAC voltage reference output for external connections to either DAC2OUTx pin. [Figure 24-2](#) shows an example buffering technique.

# PIC16(L)F1717/8/9

**FIGURE 24-1: DIGITAL-TO-ANALOG CONVERTER BLOCK DIAGRAM**



**FIGURE 24-2: VOLTAGE REFERENCE OUTPUT BUFFER EXAMPLE**



## 24.4 Operation During Sleep

When the device wakes up from Sleep through an interrupt or a Watchdog Timer time-out, the contents of the DAC2CON0 register are not affected. To minimize current consumption in Sleep mode, the voltage reference should be disabled.

## 24.5 Effects of a Reset

A device Reset affects the following:

- DAC is disabled
- DAC output voltage is removed from the DAC2OUTx pin
- The DAC2R<4:0> range select bits are cleared

## 24.6 Register Definitions: DAC Control

### REGISTER 24-1: DAC2CON0: VOLTAGE REFERENCE CONTROL REGISTER 0

R/W-0/0	U-0	R/W-0/0	R/W-0/0	R/W-0/0	R/W-0/0	U-0	R/W-0/0
DAC2EN	—	DAC2OE1	DAC2OE2	DAC2PSS<1:0>		—	DAC2NSS
bit 7							bit 0

#### Legend:

R = Readable bit	W = Writable bit	U = Unimplemented bit, read as '0'
u = Bit is unchanged	x = Bit is unknown	-n/n = Value at POR and BOR/Value at all other Resets
'1' = Bit is set	'0' = Bit is cleared	

bit 7	<b>DAC2EN:</b> DAC2 Enable bit 1 = DAC is enabled 0 = DAC is disabled
bit 6	<b>Unimplemented:</b> Read as '0'
bit 5	<b>DAC2OE1:</b> DAC2 Voltage Output Enable bit 1 = DAC voltage level is also an output on the DAC2OUT1 pin 0 = DAC voltage level is disconnected from the DAC2OUT1 pin
bit 4	<b>DAC2OE2:</b> DAC2 Voltage Output Enable bit 1 = DAC voltage level is also an output on the DAC2OUT2 pin 0 = DAC voltage level is disconnected from the DAC2OUT2 pin
bit 3-2	<b>DAC2PSS&lt;1:0&gt;:</b> DAC2 Positive Source Select bits 11 = Reserved, do not use 10 = FVR Buffer2 output 01 = VREF+ pin 00 = VDD
bit 1	<b>Unimplemented:</b> Read as '0'
bit 0	<b>DAC2NSS:</b> DAC2 Negative Source Select bits 1 = VREF- 0 = VSS

### REGISTER 24-2: DAC2CON1: VOLTAGE REFERENCE CONTROL REGISTER 1

U-0	U-0	U-0	R/W-0/0	R/W-0/0	R/W-0/0	R/W-0/0	R/W-0/0
—	—	—	DAC2R<4:0>				
bit 7							bit 0

#### Legend:

R = Readable bit	W = Writable bit	U = Unimplemented bit, read as '0'
u = Bit is unchanged	x = Bit is unknown	-n/n = Value at POR and BOR/Value at all other Resets
'1' = Bit is set	'0' = Bit is cleared	

bit 7-5	<b>Unimplemented:</b> Read as '0'
bit 4-0	<b>DAC2R&lt;4:0&gt;:</b> DAC Voltage Output Select bits

### TABLE 24-1: SUMMARY OF REGISTERS ASSOCIATED WITH THE DAC2 MODULE

Name	Bit 7	Bit 6	Bit 5	Bit 4	Bit 3	Bit 2	Bit 1	Bit 0	Register on page
DAC2CON0	DAC2EN	—	DAC2OE1	DAC2OE2	DAC2PSS<1:0>		—	DAC2NSS	263
DAC2CON1	—	—	—	DAC2R<4:0>					263

**Legend:** — = Unimplemented location, read as '0'. Shaded cells are not used with the DAC module.

# PIC16(L)F1717/8/9

## 25.0 ZERO-CROSS DETECTION (ZCD) MODULE

The ZCD module detects when an A/C signal crosses through the ground potential. The actual zero-crossing threshold is the zero-crossing reference voltage, ZCPINV, which is typically 0.75 V above ground.

The connection to the signal to be detected is through a series current limiting resistor. The module applies a current source or sink to the ZCD pin to maintain a constant voltage on the pin, thereby preventing the pin voltage from forward biasing the ESD protection diodes. When the applied voltage is greater than the reference voltage, the module sinks current. When the applied voltage is less than the reference voltage, the module sources current. The current source and sink action keeps the pin voltage constant over the full range of the applied voltage. The ZCD module is shown in the simplified block diagram [Figure 25-2](#).

The ZCD module is useful when monitoring an AC waveform for, but not limited to, the following purposes:

- A/C period measurement
- Accurate long term time measurement
- Dimmer phase delayed drive
- Low EMI cycle switching

## 25.1 External Resistor Selection

The ZCD module requires a current limiting resistor in series with the external voltage source. The impedance and rating of this resistor depends on the external source peak voltage. Select a resistor value that will drop all of the peak voltage when the current through the resistor is nominally 300  $\mu$ A. Refer to [Equation 25-1](#) and [Figure 25-1](#). Make sure that the ZCD I/O pin internal weak pull-up is disabled so it doesn't interfere with the current source and sink.

### EQUATION 25-1: EXTERNAL RESISTOR

$$R_{series} = \frac{V_{peak}}{3 \times 10^{-4}}$$

FIGURE 25-1: EXTERNAL VOLTAGE

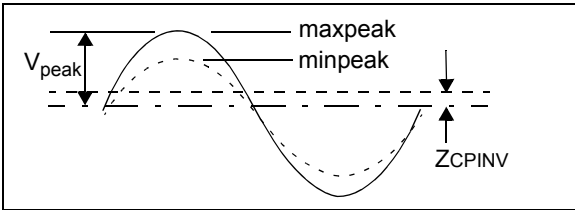
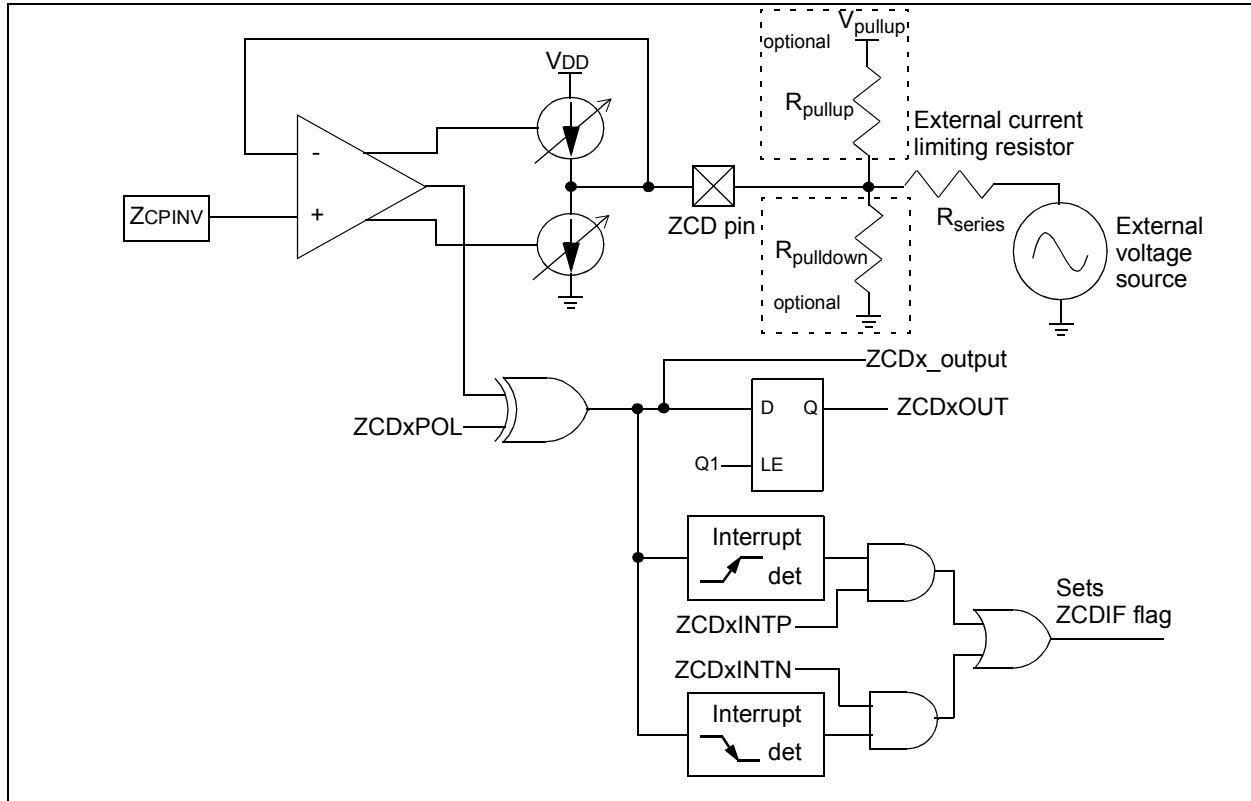


FIGURE 25-2: SIMPLIFIED ZCD BLOCK DIAGRAM





## 25.2 ZCD Logic Output

The ZCD module includes a Status bit, which can be read to determine whether the current source or sink is active. The ZCDxOUT bit of the ZCDxCON register is set when the current sink is active, and cleared when the current source is active. The ZCDxOUT bit is affected by the polarity bit.

## 25.3 ZCD Logic Polarity

The ZCDxPOL bit of the ZCDxCON register inverts the ZCDxOUT bit relative to the current source and sink output. When the ZCDxPOL bit is set, a ZCDxOUT high indicates that the current source is active, and a low output indicates that the current sink is active.

The ZCDxPOL bit affects the ZCD interrupts. See [Section 25.4 “ZCD Interrupts”](#).

## 25.4 ZCD Interrupts

An interrupt will be generated upon a change in the ZCD logic output when the appropriate interrupt enables are set. A rising edge detector and a falling edge detector are present in the ZCD for this purpose.

The ZCDIF bit of the PIR3 register will be set when either edge detector is triggered and its associated enable bit is set. The ZCDxINTP enables rising edge interrupts and the ZCDxINTN bit enables falling edge interrupts. Both are located in the ZCDxCON register.

To fully enable the interrupt, the following bits must be set:

- ZCDIE bit of the PIE3 register
- ZCDxINTP bit of the ZCDxCON register (for a rising edge detection)
- ZCDxINTN bit of the ZCDxCON register (for a falling edge detection)
- PEIE and GIE bits of the INTCON register

Changing the ZCDxPOL bit will cause an interrupt, regardless of the level of the ZCDxEN bit.

The ZCDIF bit of the PIR3 register must be cleared in software as part of the interrupt service. If another edge is detected while this flag is being cleared, the flag will still be set at the end of the sequence.

## 25.5 Correcting for ZCPINV Offset

The actual voltage at which the ZCD switches is the reference voltage at the non-inverting input of the ZCD op amp. For external voltage source waveforms other than square waves this voltage offset from zero causes the zero-cross event to occur either too early or too late. When the waveform is varying relative to V<sub>SS</sub> then the zero cross is detected too early as the waveform falls and too late as the waveform rises. When the waveform is varying relative to V<sub>DD</sub> then the zero cross is detected too late as the waveform rises and too early as the waveform falls. The actual offset time can be determined for sinusoidal waveforms with the corresponding equations shown in [Equation 25-2](#).

### EQUATION 25-2: ZCD EVENT OFFSET

When External Voltage Source is relative to V<sub>SS</sub>:

$$T_{offset} = \frac{\text{asin}\left(\frac{Z_{cpinv}}{V_{peak}}\right)}{2\pi \cdot Freq}$$

When External Voltage Source is relative to V<sub>DD</sub>:

$$T_{offset} = \frac{\text{asin}\left(\frac{V_{DD}-Z_{cpinv}}{V_{peak}}\right)}{2\pi \cdot Freq}$$

This offset time can be compensated for by adding a pull-up or pull-down biasing resistor to the ZCD pin. A pull-up resistor is used when the external voltage source is varying relative to V<sub>SS</sub>. A pull-down resistor is used when the voltage is varying relative to V<sub>DD</sub>. The resistor adds a bias to the ZCD pin so that the target external voltage source must go to zero to pull the pin voltage to the ZCPINV switching voltage. The pull-up or pull-down value can be determined with the equations shown in [Equation 25-3](#).

### EQUATION 25-3: ZCD PULL-UP/DOWN

When External Signal is relative to V<sub>SS</sub>:

$$R_{pullup} = \frac{R_{series}(V_{pullup} - Z_{cpinv})}{Z_{cpinv}}$$

When External Signal is relative to V<sub>DD</sub>:

$$R_{pulldown} = \frac{R_{series}(Z_{cpinv})}{(V_{DD} - Z_{cpinv})}$$

The pull-up and pull-down resistor values are significantly affected by small variations of ZCPINV. Measuring ZCPINV can be difficult, especially when the waveform is relative to V<sub>DD</sub>. However, by combining [Equation 25-2](#) and [Equation 25-3](#) the resistor value

# PIC16(L)F1717/8/9

can be determined from the time difference between the ZCDOUT high and low periods. Note that the time difference,  $\Delta T$ , is  $4 \cdot T_{\text{offset}}$ . The equation for determining the pull-up and pull-down resistor values from the high and low ZCDOUT periods is shown in [Equation 25-4](#). The ZCDOUT signal can be directly observed on a pin by routing the ZCDOUT signal through one of the CLCs.

## EQUATION 25-4:

$$R = R_{\text{series}} \left( \frac{V_{\text{bias}}}{V_{\text{peak}} \left( \sin \left( \pi \text{Freq} \frac{\Delta T}{2} \right) \right)} - 1 \right)$$

R is pull-up or pull-down resistor

$V_{\text{bias}}$  is  $V_{\text{pullup}}$  when R is pull-up or  $V_{\text{DD}}$  when R is pull-down

$\Delta T$  is the ZCDOUT high and low period difference

## 25.6 Handling $V_{\text{peak}}$ variations

If the peak amplitude of the external voltage is expected to vary then the series resistor must be selected to keep the ZCD current source and sink below the design maximum range of  $\pm 600 \mu\text{A}$  for the maximum expected voltage and high enough to be detected accurately at the minimum peak voltage. A general rule of thumb is that the maximum peak voltage can be no more than six times the minimum peak voltage. To ensure that the maximum current does not exceed  $\pm 600 \mu\text{A}$  and the minimum is at least  $\pm 100 \mu\text{A}$  compute the series resistance as shown in [Equation 25-5](#). The compensating pull-up for this series resistance can be determined with [Equation 25-3](#) because the pull-up value is independent from the peak voltage.

## EQUATION 25-5: SERIES R FOR V RANGE

$$R_{\text{series}} = \frac{V_{\text{maxpeak}} + V_{\text{minpeak}}}{7 \times 10^{-4}}$$

## 25.7 Operation During Sleep

The ZCD current sources and interrupts are unaffected by Sleep.

## 25.8 Effects of a Reset

The ZCD circuit can be configured to default to the active or inactive state on Power-On-Reset (POR). When the ZCDDIS Configuration bit is cleared, the ZCD circuit will be active at POR. When the ZCDDIS Configuration bit is set, the ZCDxEN bit of the ZCDxCON register must be set to enable the ZCD module.

## 25.9 Register Definitions: ZCD Control

**REGISTER 25-1: ZCDxCON: ZERO-CROSS DETECTION CONTROL REGISTER**

R/W-0/0	U-0	R-x/x	R/W-0/0	U-0	U-0	R/W-0/0	R/W-0/0
ZCDxEN	—	ZCDxOUT	ZCDxPOL	—	—	ZCDxINTP	ZCDxINTN
bit 7							bit 0

**Legend:**

R = Readable bit	W = Writable bit	U = Unimplemented bit, read as '0'
u = Bit is unchanged	x = Bit is unknown	-n/n = Value at POR and BOR/Value at all other Resets
'1' = Bit is set	'0' = Bit is cleared	q = value depends on configuration bits

- bit 7      **ZCDxEN:** Zero-Cross Detection Enable bit<sup>(1)</sup>  
 1 = Zero-cross detect is enabled. ZCD pin is forced to output to source and sink current.  
 0 = Zero-cross detect is disabled. ZCD pin operates according to PPS and TRIS controls.
- bit 6      **Unimplemented:** Read as '0'
- bit 5      **ZCDxOUT:** Zero-Cross Detection Logic Level bit  
ZCDxPOL bit = 0:  
 1 = ZCD pin is sinking current  
 0 = ZCD pin is sourcing current  
ZCDxPOL bit = 1:  
 1 = ZCD pin is sourcing current  
 0 = ZCD pin is sinking current
- bit 4      **ZCDxPOL:** Zero-Cross Detection Logic Output Polarity bit  
 1 = ZCD logic output is inverted  
 0 = ZCD logic output is not inverted
- bit 3-2    **Unimplemented:** Read as '0'
- bit 1      **ZCDxINTP:** Zero-Cross Positive Edge Interrupt Enable bit  
 1 = ZCDIF bit is set on low-to-high ZCDxOUT transition  
 0 = ZCDIF bit is unaffected by low-to-high ZCDxOUT transition
- bit 0      **ZCDxINTN:** Zero-Cross Negative Edge Interrupt Enable bit  
 1 = ZCDIF bit is set on high-to-low ZCDxOUT transition  
 0 = ZCDIF bit is unaffected by high-to-low ZCDxOUT transition

**Note 1:** The ZCDxEN bit has no effect when the ZCDDIS Configuration bit is cleared.

**TABLE 25-1: SUMMARY OF REGISTERS ASSOCIATED WITH THE ZCD MODULE**

Name	Bit 7	Bit 6	Bit 5	Bit 4	Bit 3	Bit 2	Bit 1	Bit 0	Register on page
PIE3	—	NCOIE	COGIE	ZCDIE	CLC4IE	CLC3IE	CLC2IE	CLC1IE	93
PIR3	—	NCOIF	COGIF	ZCDIF	CLC4IF	CLC3IF	CLC2IF	CLC1IF	96
ZCD1CON	ZCD1EN	—	ZCD1OUT	ZCD1POL	—	—	ZCD1INTP	ZCD1INTN	267

**Legend:** — = unimplemented, read as '0'. Shaded cells are unused by the ZCD module.

**TABLE 25-2: SUMMARY OF CONFIGURATION WORD WITH THE ZCD MODULE**

Name	Bits	Bit -/7	Bit -/6	Bit 13/5	Bit 12/4	Bit 11/3	Bit 10/2	Bit 9/1	Bit 8/0	Register on Page
CONFIG2	13:8	—	—	LVP	DEBUG	LPBOR	BORV	STVREN	PLLEN	57
	7:0	ZCDDIS	—	—	—	—	PPS1WAY	WRT<1:0>		

**Legend:** — = unimplemented location, read as '0'. Shaded cells are not used by the ZCD module.

# PIC16(L)F1717/8/9

## 26.0 TIMER0 MODULE

The Timer0 module is an 8-bit timer/counter with the following features:

- 8-bit timer/counter register (TMR0)
- 8-bit prescaler (independent of Watchdog Timer)
- Programmable internal or external clock source
- Programmable external clock edge selection
- Interrupt on overflow
- TMR0 can be used to gate Timer1

Figure 26-1 is a block diagram of the Timer0 module.

### 26.1 Timer0 Operation

The Timer0 module can be used as either an 8-bit timer or an 8-bit counter.

#### 26.1.1 8-BIT TIMER MODE

The Timer0 module will increment every instruction cycle, if used without a prescaler. 8-bit Timer mode is selected by clearing the TMR0CS bit of the OPTION\_REG register.

When TMR0 is written, the increment is inhibited for two instruction cycles immediately following the write.

**Note:** The value written to the TMR0 register can be adjusted, in order to account for the two instruction cycle delay when TMR0 is written.

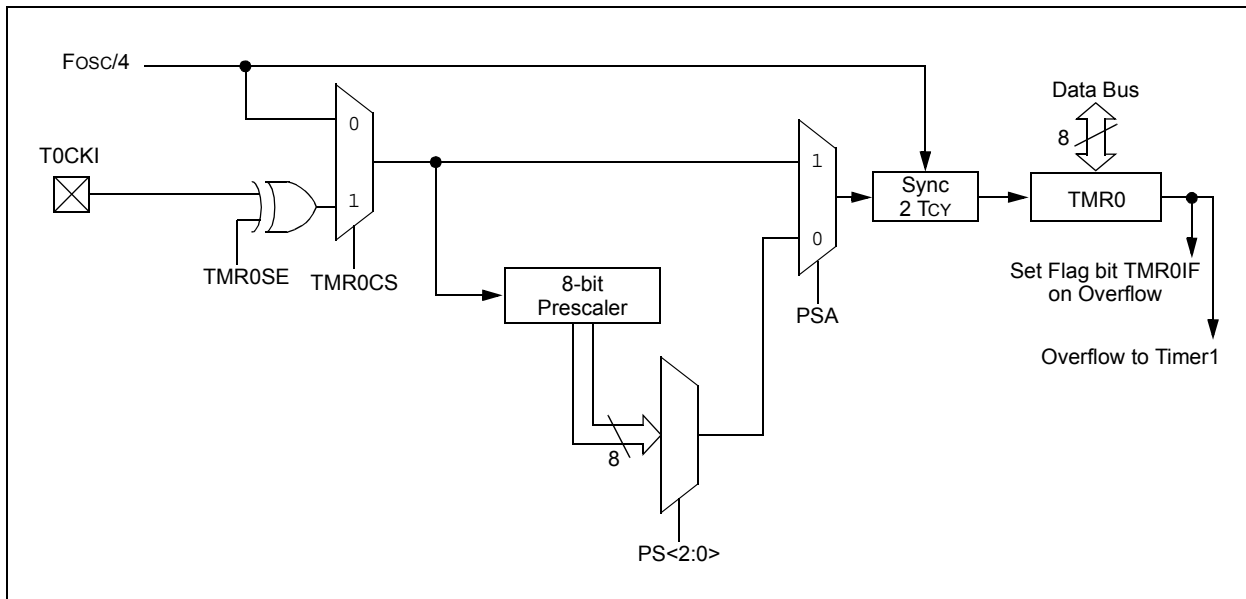
#### 26.1.2 8-BIT COUNTER MODE

In 8-Bit Counter mode, the Timer0 module will increment on every rising or falling edge of the T0CKI pin.

8-Bit Counter mode using the T0CKI pin is selected by setting the TMR0CS bit in the OPTION\_REG register to '1'.

The rising or falling transition of the incrementing edge for either input source is determined by the TMR0SE bit in the OPTION\_REG register.

FIGURE 26-1: BLOCK DIAGRAM OF THE TIMER0



## 26.1.3 SOFTWARE PROGRAMMABLE PRESCALER

A software programmable prescaler is available for exclusive use with Timer0. The prescaler is enabled by clearing the PSA bit of the OPTION\_REG register.

**Note:** The Watchdog Timer (WDT) uses its own independent prescaler.

There are eight prescaler options for the Timer0 module ranging from 1:2 to 1:256. The prescale values are selectable via the PS<2:0> bits of the OPTION\_REG register. In order to have a 1:1 prescaler value for the Timer0 module, the prescaler must be disabled by setting the PSA bit of the OPTION\_REG register.

The prescaler is not readable or writable. All instructions writing to the TMR0 register will clear the prescaler.

## 26.1.4 TIMER0 INTERRUPT

Timer0 will generate an interrupt when the TMR0 register overflows from FFh to 00h. The TMR0IF interrupt flag bit of the INTCON register is set every time the TMR0 register overflows, regardless of whether or not the Timer0 interrupt is enabled. The TMR0IF bit can only be cleared in software. The Timer0 interrupt enable is the TMR0IE bit of the INTCON register.

**Note:** The Timer0 interrupt cannot wake the processor from Sleep since the timer is frozen during Sleep.

## 26.1.5 8-BIT COUNTER MODE SYNCHRONIZATION

When in 8-Bit Counter mode, the incrementing edge on the T0CKI pin must be synchronized to the instruction clock. Synchronization can be accomplished by sampling the prescaler output on the Q2 and Q4 cycles of the instruction clock. The high and low periods of the external clocking source must meet the timing requirements as shown in [Table 34-12: Timer0 and Timer1 External Clock Requirements](#).

## 26.1.6 OPERATION DURING SLEEP

Timer0 cannot operate while the processor is in Sleep mode. The contents of the TMR0 register will remain unchanged while the processor is in Sleep mode.

# PIC16(L)F1717/8/9

## 26.2 Register Definitions: Option Register

**REGISTER 26-1: OPTION\_REG: OPTION REGISTER**

R/W-1/1	R/W-1/1	R/W-1/1	R/W-1/1	R/W-1/1	R/W-1/1	R/W-1/1	R/W-1/1
WPUEN	INTEDG	TMR0CS	TMR0SE	PSA	PS<2:0>		
bit 7							bit 0

**Legend:**

R = Readable bit                      W = Writable bit                      U = Unimplemented bit, read as '0'  
u = Bit is unchanged                      x = Bit is unknown                      -n/n = Value at POR and BOR/Value at all other Resets  
'1' = Bit is set                              '0' = Bit is cleared

- bit 7            **WPUEN:** Weak Pull-Up Enable bit  
1 = All weak pull-ups are disabled (except  $\overline{\text{MCLR}}$ , if it is enabled)  
0 = Weak pull-ups are enabled by individual WPUx latch values
- bit 6            **INTEDG:** Interrupt Edge Select bit  
1 = Interrupt on rising edge of INT pin  
0 = Interrupt on falling edge of INT pin
- bit 5            **TMR0CS:** Timer0 Clock Source Select bit  
1 = Transition on T0CKI pin  
0 = Internal instruction cycle clock (FOSC/4)
- bit 4            **TMR0SE:** Timer0 Source Edge Select bit  
1 = Increment on high-to-low transition on T0CKI pin  
0 = Increment on low-to-high transition on T0CKI pin
- bit 3            **PSA:** Prescaler Assignment bit  
1 = Prescaler is not assigned to the Timer0 module  
0 = Prescaler is assigned to the Timer0 module
- bit 2-0        **PS<2:0>:** Prescaler Rate Select bits

Bit Value	Timer0 Rate
000	1 : 2
001	1 : 4
010	1 : 8
011	1 : 16
100	1 : 32
101	1 : 64
110	1 : 128
111	1 : 256

**TABLE 26-1: SUMMARY OF REGISTERS ASSOCIATED WITH TIMER0**

Name	Bit 7	Bit 6	Bit 5	Bit 4	Bit 3	Bit 2	Bit 1	Bit 0	Register on Page
INTCON	GIE	PEIE	TMR0IE	INTE	IOCIE	TMR0IF	INTF	IOCIF	90
OPTION_REG	WPUEN	INTEDG	TMR0CS	TMR0SE	PSA	PS<2:0>			270
TMR0	Timer0 Module Register								268*
TRISA	TRISA7	TRISA6	TRISA5	TRISA4	TRISA3	TRISA2	TRISA1	TRISA0	124

**Legend:** — = Unimplemented location, read as '0'. Shaded cells are not used by the Timer0 module.  
\* Page provides register information.

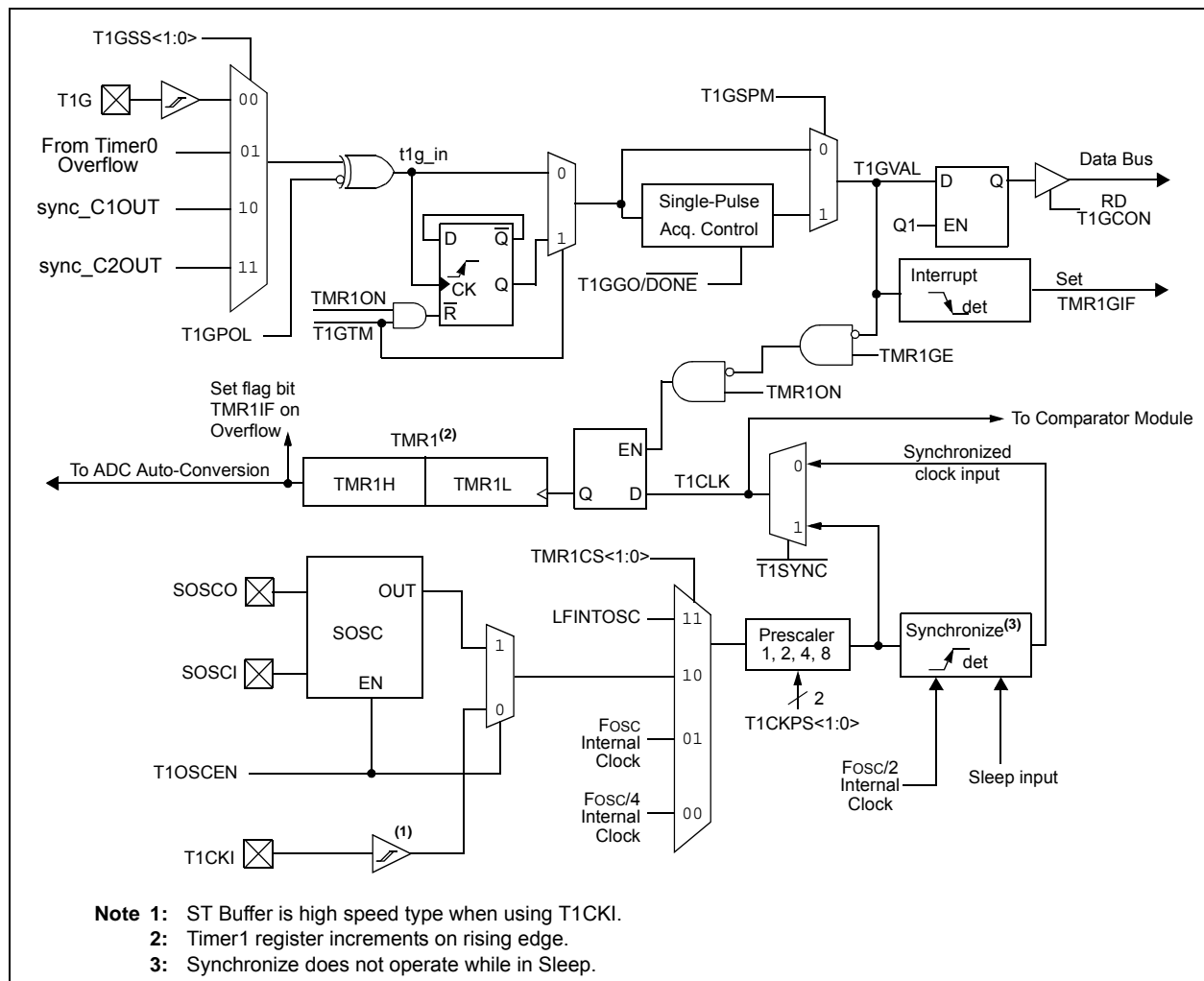
## 27.0 TIMER1 MODULE WITH GATE CONTROL

The Timer1 module is a 16-bit timer/counter with the following features:

- 16-bit timer/counter register pair (TMR1H:TMR1L)
- Programmable internal or external clock source
- 2-bit prescaler
- Dedicated 32 kHz oscillator circuit
- Optionally synchronized comparator out
- Multiple Timer1 gate (count enable) sources
- Interrupt on overflow
- Wake-up on overflow (external clock, Asynchronous mode only)
- Time base for the Capture/Compare function
- Auto-conversion Trigger (with CCP)
- Selectable Gate Source Polarity
- Gate Toggle mode
- Gate Single-pulse mode
- Gate Value Status
- Gate Event Interrupt

Figure 27-1 is a block diagram of the Timer1 module.

**FIGURE 27-1: TIMER1 BLOCK DIAGRAM**



# PIC16(L)F1717/8/9

## 27.1 Timer1 Operation

The Timer1 module is a 16-bit incrementing counter which is accessed through the TMR1H:TMR1L register pair. Writes to TMR1H or TMR1L directly update the counter.

When used with an internal clock source, the module is a timer and increments on every instruction cycle. When used with an external clock source, the module can be used as either a timer or counter and increments on every selected edge of the external source.

Timer1 is enabled by configuring the TMR1ON and TMR1GE bits in the T1CON and T1GCON registers, respectively. Table 27-1 displays the Timer1 enable selections.

**TABLE 27-1: TIMER1 ENABLE SELECTIONS**

TMR1ON	TMR1GE	Timer1 Operation
0	0	Off
0	1	Off
1	0	Always On
1	1	Count Enabled

## 27.2 Clock Source Selection

The TMR1CS<1:0> and T1OSCEN bits of the T1CON register are used to select the clock source for Timer1. Table 27-2 displays the clock source selections.

### 27.2.1 INTERNAL CLOCK SOURCE

When the internal clock source is selected, the TMR1H:TMR1L register pair will increment on multiples of FOSC as determined by the Timer1 prescaler.

When the Fosc internal clock source is selected, the Timer1 register value will increment by four counts every instruction clock cycle. Due to this condition, a 2 LSB error in resolution will occur when reading the Timer1 value. To utilize the full resolution of Timer1, an asynchronous input signal must be used to gate the Timer1 clock input.

The following asynchronous sources may be used:

- Asynchronous event on the T1G pin to Timer1 gate
- C1 or C2 comparator input to Timer1 gate

### 27.2.2 EXTERNAL CLOCK SOURCE

When the external clock source is selected, the Timer1 module may work as a timer or a counter.

When enabled to count, Timer1 is incremented on the rising edge of the external clock input T1CKI, which can be synchronized to the microcontroller system clock or can run asynchronously.

When used as a timer with a clock oscillator, an external 32.768 kHz crystal can be used in conjunction with the dedicated internal oscillator circuit.

**Note:** In Counter mode, a falling edge must be registered by the counter prior to the first incrementing rising edge after any one or more of the following conditions:

- Timer1 enabled after POR
- Write to TMR1H or TMR1L
- Timer1 is disabled
- Timer1 is disabled (TMR1ON = 0) when T1CKI is high then Timer1 is enabled (TMR1ON=1) when T1CKI is low.

**TABLE 27-2: CLOCK SOURCE SELECTIONS**

TMR1CS<1:0>	T1OSCEN	Clock Source
11	x	LFINTOSC
10	0	External Clocking on T1CKI Pin
01	x	System Clock (Fosc)
00	x	Instruction Clock (Fosc/4)



## 27.3 Timer1 Prescaler

Timer1 has four prescaler options allowing 1, 2, 4 or 8 divisions of the clock input. The T1CKPS bits of the T1CON register control the prescale counter. The prescale counter is not directly readable or writable; however, the prescaler counter is cleared upon a write to TMR1H or TMR1L.

## 27.4 Timer1 (Secondary) Oscillator

A dedicated low-power 32.768 kHz oscillator circuit is built-in between pins SOSC1 (input) and SOSCO (amplifier output). This internal circuit is to be used in conjunction with an external 32.768 kHz crystal.

The oscillator circuit is enabled by setting the T1OSCEN bit of the T1CON register. The oscillator will continue to run during Sleep.

**Note:** The oscillator requires a start-up and stabilization time before use. Thus, T1OSCEN should be set and a suitable delay observed prior to using Timer1. A suitable delay similar to the OST delay can be implemented in software by clearing the TMR1IF bit then presetting the TMR1H:TMR1L register pair to FC00h. The TMR1IF flag will be set when 1024 clock cycles have elapsed, thereby indicating that the oscillator is running and reasonably stable.

## 27.5 Timer1 Operation in Asynchronous Counter Mode

If the control bit  $\overline{T1SYNC}$  of the T1CON register is set, the external clock input is not synchronized. The timer increments asynchronously to the internal phase clocks. If the external clock source is selected then the timer will continue to run during Sleep and can generate an interrupt on overflow, which will wake-up the processor. However, special precautions in software are needed to read/write the timer (see [Section 27.5.1 “Reading and Writing Timer1 in Asynchronous Counter Mode”](#)).

**Note:** When switching from synchronous to asynchronous operation, it is possible to skip an increment. When switching from asynchronous to synchronous operation, it is possible to produce an additional increment.

### 27.5.1 READING AND WRITING TIMER1 IN ASYNCHRONOUS COUNTER MODE

Reading TMR1H or TMR1L while the timer is running from an external asynchronous clock will ensure a valid read (taken care of in hardware). However, the user should keep in mind that reading the 16-bit timer in two 8-bit values itself, poses certain problems, since the timer may overflow between the reads.

For writes, it is recommended that the user simply stop the timer and write the desired values. A write contention may occur by writing to the timer registers, while the register is incrementing. This may produce an unpredictable value in the TMR1H:TMR1L register pair.

## 27.6 Timer1 Gate

Timer1 can be configured to count freely or the count can be enabled and disabled using Timer1 gate circuitry. This is also referred to as Timer1 Gate Enable.

Timer1 gate can also be driven by multiple selectable sources.

### 27.6.1 TIMER1 GATE ENABLE

The Timer1 Gate Enable mode is enabled by setting the TMR1GE bit of the T1GCON register. The polarity of the Timer1 Gate Enable mode is configured using the T1GPOL bit of the T1GCON register.

When Timer1 Gate Enable mode is enabled, Timer1 will increment on the rising edge of the Timer1 clock source. When Timer1 Gate Enable mode is disabled, no incrementing will occur and Timer1 will hold the current count. See [Figure 27-3](#) for timing details.

**TABLE 27-3: TIMER1 GATE ENABLE SELECTIONS**

T1CLK	T1GPOL	T1G	Timer1 Operation
↑	0	0	Counts
↑	0	1	Holds Count
↑	1	0	Holds Count
↑	1	1	Counts

# PIC16(L)F1717/8/9

## 27.6.2 TIMER1 GATE SOURCE SELECTION

Timer1 gate source selections are shown in [Table 27-4](#). Source selection is controlled by the T1GSS bits of the T1GCON register. The polarity for each available source is also selectable. Polarity selection is controlled by the T1GPOL bit of the T1GCON register.

**TABLE 27-4: TIMER1 GATE SOURCES**

T1GSS	Timer1 Gate Source
00	Timer1 Gate Pin
01	Overflow of Timer0 (TMR0 increments from FFh to 00h)
10	Comparator 1 Output sync_C1OUT (optionally Timer1 synchronized output)
11	Comparator 2 Output sync_C2OUT (optionally Timer1 synchronized output)

### 27.6.2.1 T1G Pin Gate Operation

The T1G pin is one source for Timer1 gate control. It can be used to supply an external source to the Timer1 gate circuitry.

### 27.6.2.2 Timer0 Overflow Gate Operation

When Timer0 increments from FFh to 00h, a low-to-high pulse will automatically be generated and internally supplied to the Timer1 gate circuitry.

### 27.6.2.3 Comparator C1 Gate Operation

The output resulting from a Comparator 1 operation can be selected as a source for Timer1 gate control. The Comparator 1 output (sync\_C1OUT) can be synchronized to the Timer1 clock or left asynchronous. For more information see [Section 16.4.1 “Comparator Output Synchronization”](#).

### 27.6.2.4 Comparator C2 Gate Operation

The output resulting from a Comparator 2 operation can be selected as a source for Timer1 gate control. The Comparator 2 output (sync\_C2OUT) can be synchronized to the Timer1 clock or left asynchronous. For more information see [Section 16.4.1 “Comparator Output Synchronization”](#).

## 27.6.3 TIMER1 GATE TOGGLE MODE

When Timer1 Gate Toggle mode is enabled, it is possible to measure the full-cycle length of a Timer1 gate signal, as opposed to the duration of a single level pulse.

The Timer1 gate source is routed through a flip-flop that changes state on every incrementing edge of the signal. See [Figure 27-4](#) for timing details.

Timer1 Gate Toggle mode is enabled by setting the T1GTM bit of the T1GCON register. When the T1GTM bit is cleared, the flip-flop is cleared and held clear. This is necessary in order to control which edge is measured.

**Note:** Enabling Toggle mode at the same time as changing the gate polarity may result in indeterminate operation.

## 27.6.4 TIMER1 GATE SINGLE-PULSE MODE

When Timer1 Gate Single-Pulse mode is enabled, it is possible to capture a single-pulse gate event. Timer1 Gate Single-Pulse mode is first enabled by setting the T1GSPM bit in the T1GCON register. Next, the T1GGO/DONE bit in the T1GCON register must be set. The Timer1 will be fully enabled on the next incrementing edge. On the next trailing edge of the pulse, the T1GGO/DONE bit will automatically be cleared. No other gate events will be allowed to increment Timer1 until the T1GGO/DONE bit is once again set in software. See [Figure 27-5](#) for timing details.

If the Single-Pulse Gate mode is disabled by clearing the T1GSPM bit in the T1GCON register, the T1GGO/DONE bit should also be cleared.

Enabling the Toggle mode and the Single-Pulse mode simultaneously will permit both sections to work together. This allows the cycle times on the Timer1 gate source to be measured. See [Figure 27-6](#) for timing details.

## 27.6.5 TIMER1 GATE VALUE STATUS

When Timer1 Gate Value Status is utilized, it is possible to read the most current level of the gate control value. The value is stored in the T1GVAL bit in the T1GCON register. The T1GVAL bit is valid even when the Timer1 gate is not enabled (TMR1GE bit is cleared).

## 27.6.6 TIMER1 GATE EVENT INTERRUPT

When Timer1 Gate Event Interrupt is enabled, it is possible to generate an interrupt upon the completion of a gate event. When the falling edge of T1GVAL occurs, the TMR1GIF flag bit in the PIR1 register will be set. If the TMR1GIE bit in the PIE1 register is set, then an interrupt will be recognized.

The TMR1GIF flag bit operates even when the Timer1 gate is not enabled (TMR1GE bit is cleared).

## 27.7 Timer1 Interrupt

The Timer1 register pair (TMR1H:TMR1L) increments to FFFFh and rolls over to 0000h. When Timer1 rolls over, the Timer1 interrupt flag bit of the PIR1 register is set. To enable the interrupt on rollover, you must set these bits:

- TMR1ON bit of the T1CON register
- TMR1IE bit of the PIE1 register
- PEIE bit of the INTCON register
- GIE bit of the INTCON register

The interrupt is cleared by clearing the TMR1IF bit in the Interrupt Service Routine.

**Note:** The TMR1H:TMR1L register pair and the TMR1IF bit should be cleared before enabling interrupts.

## 27.8 Timer1 Operation During Sleep

Timer1 can only operate during Sleep when setup in Asynchronous Counter mode. In this mode, an external crystal or clock source can be used to increment the counter. To set up the timer to wake the device:

- TMR1ON bit of the T1CON register must be set
- TMR1IE bit of the PIE1 register must be set
- PEIE bit of the INTCON register must be set
- T1SYNC bit of the T1CON register must be set
- TMR1CS bits of the T1CON register must be configured
- T1OSCEN bit of the T1CON register must be configured

The device will wake-up on an overflow and execute the next instructions. If the GIE bit of the INTCON register is set, the device will call the Interrupt Service Routine.

Secondary oscillator will continue to operate in Sleep regardless of the T1SYNC bit setting.

## 27.9 CCP Capture/Compare Time Base

The CCP modules use the TMR1H:TMR1L register pair as the time base when operating in Capture or Compare mode.

In Capture mode, the value in the TMR1H:TMR1L register pair is copied into the CCPR1H:CCPR1L register pair on a configured event.

In Compare mode, an event is triggered when the value CCPR1H:CCPR1L register pair matches the value in the TMR1H:TMR1L register pair. This event can be an auto-conversion trigger.

For more information, see [Section 29.0 “Capture/Compare/PWM Modules”](#).

## 27.10 CCP Auto-Conversion Trigger

When any of the CCP's are configured to trigger an auto-conversion, the trigger will clear the TMR1H:TMR1L register pair. This auto-conversion does not cause a Timer1 interrupt. The CCP module may still be configured to generate a CCP interrupt.

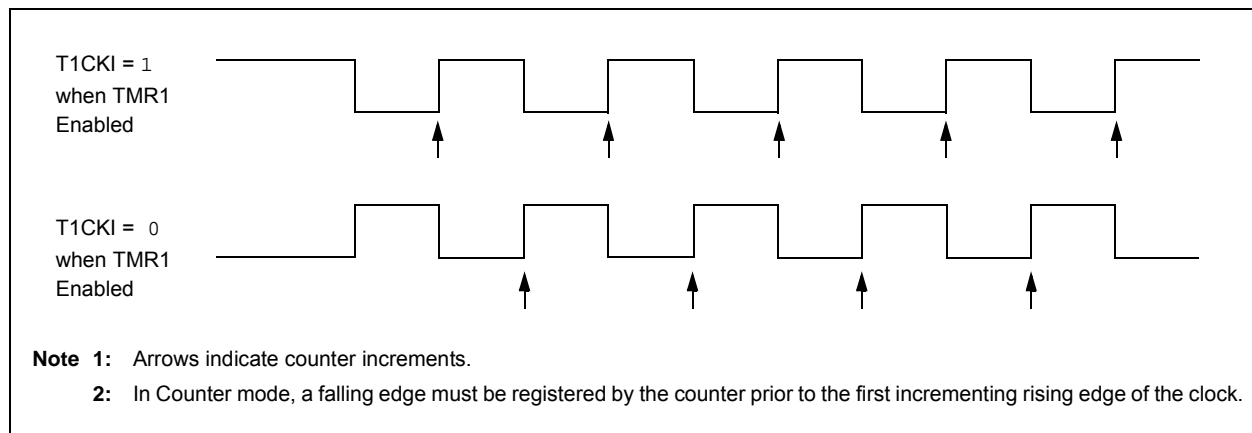
In this mode of operation, the CCPR1H:CCPR1L register pair becomes the period register for Timer1.

Timer1 should be synchronized and FOSC/4 should be selected as the clock source in order to utilize the auto-conversion trigger. Asynchronous operation of Timer1 can cause an auto-conversion trigger to be missed.

In the event that a write to TMR1H or TMR1L coincides with an auto-conversion trigger from the CCP, the write will take precedence.

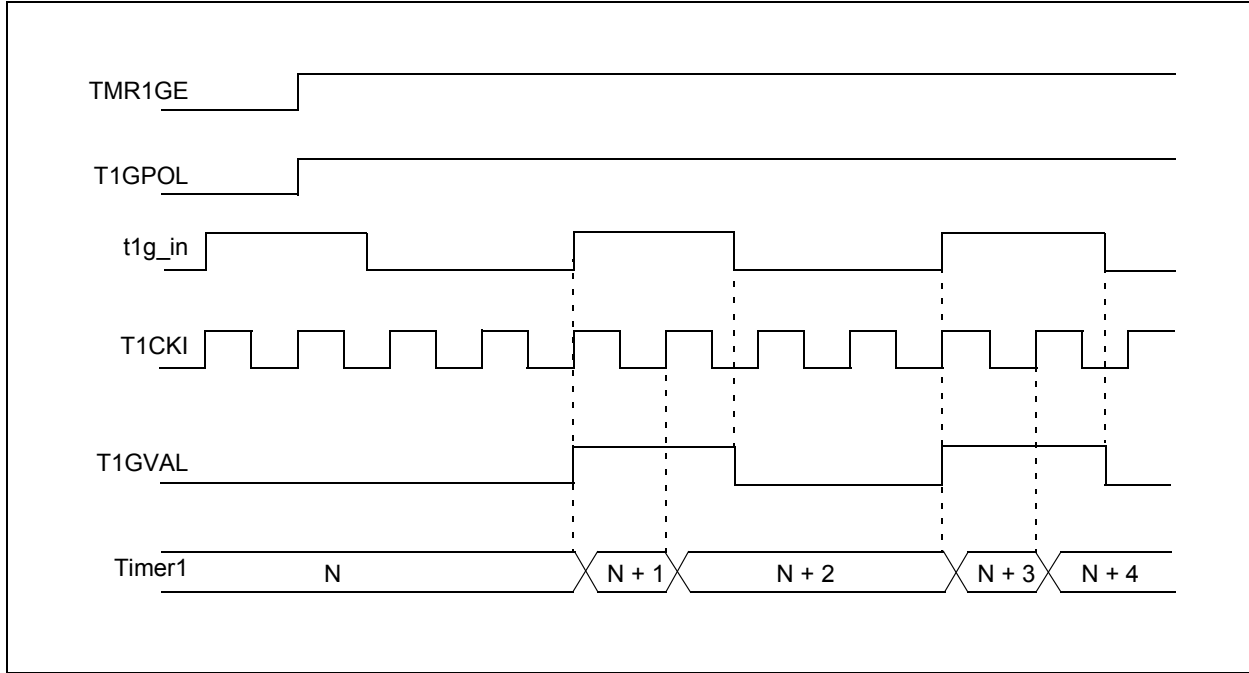
For more information, see [Section 29.2.4 “Auto-Conversion Trigger”](#).

**FIGURE 27-2: TIMER1 INCREMENTING EDGE**

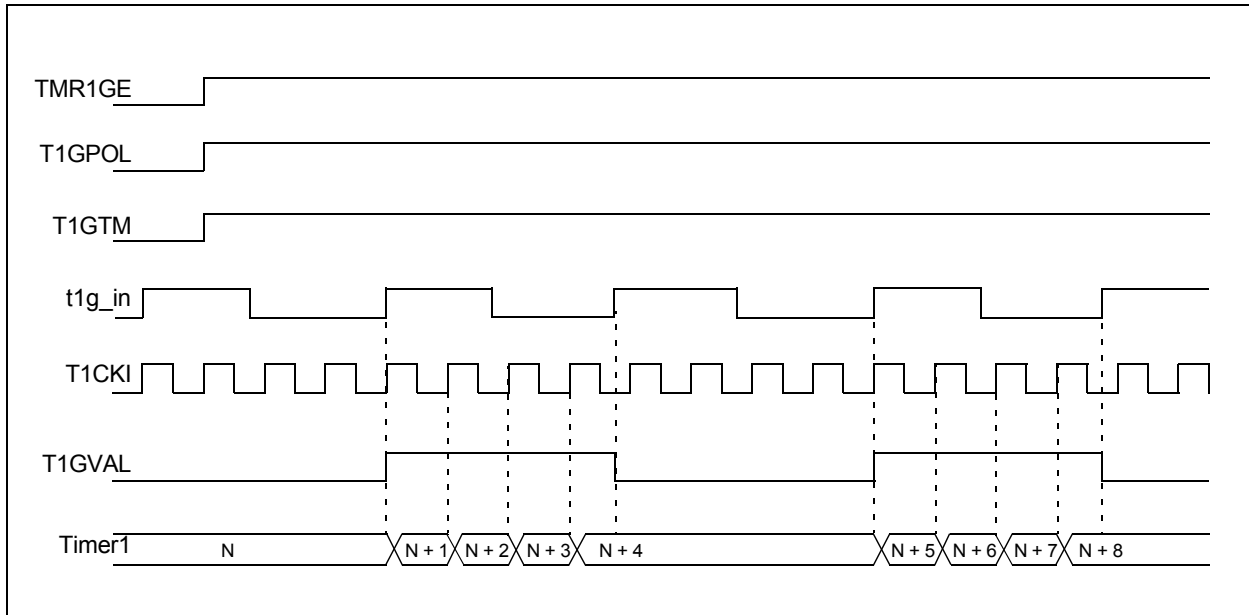


# PIC16(L)F1717/8/9

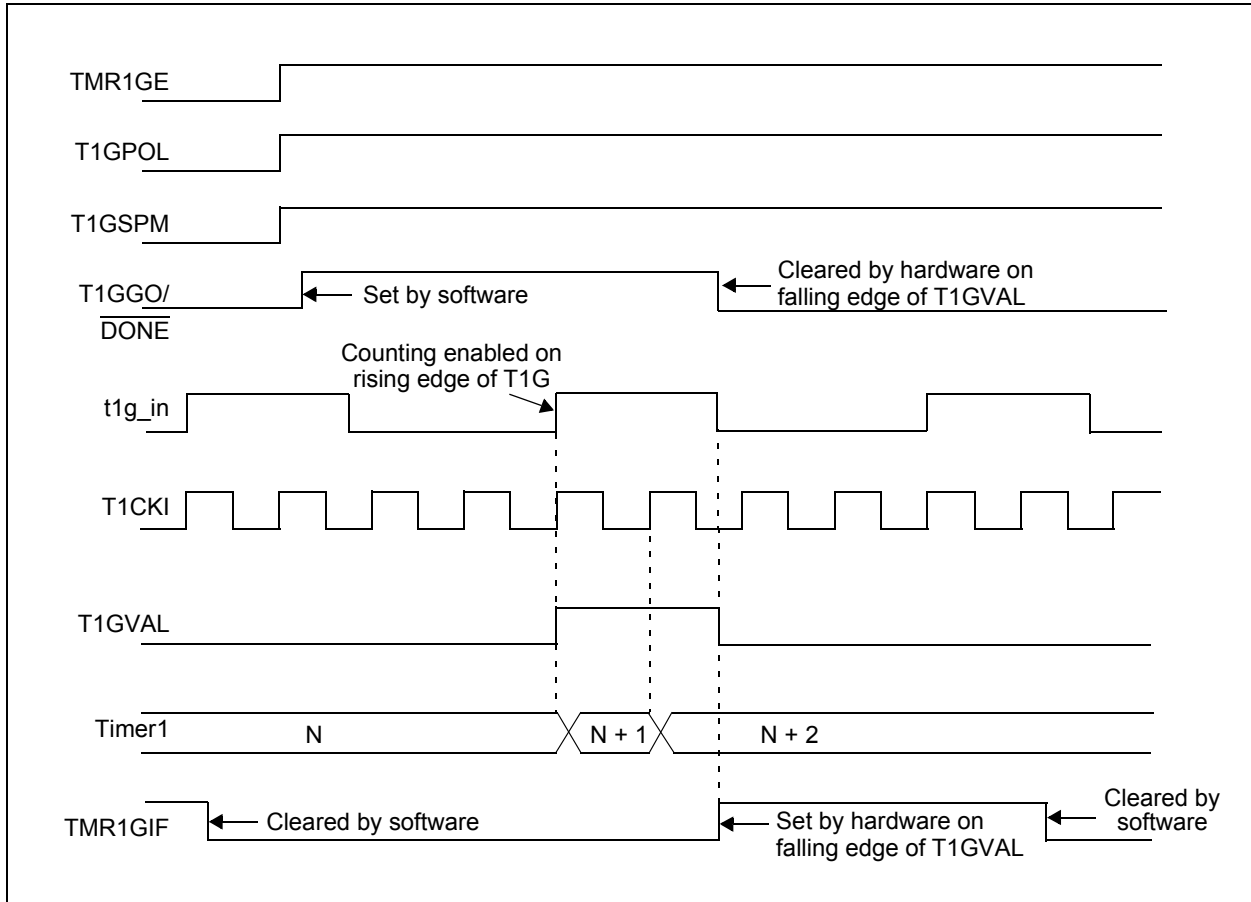
**FIGURE 27-3: TIMER1 GATE ENABLE MODE**



**FIGURE 27-4: TIMER1 GATE TOGGLE MODE**

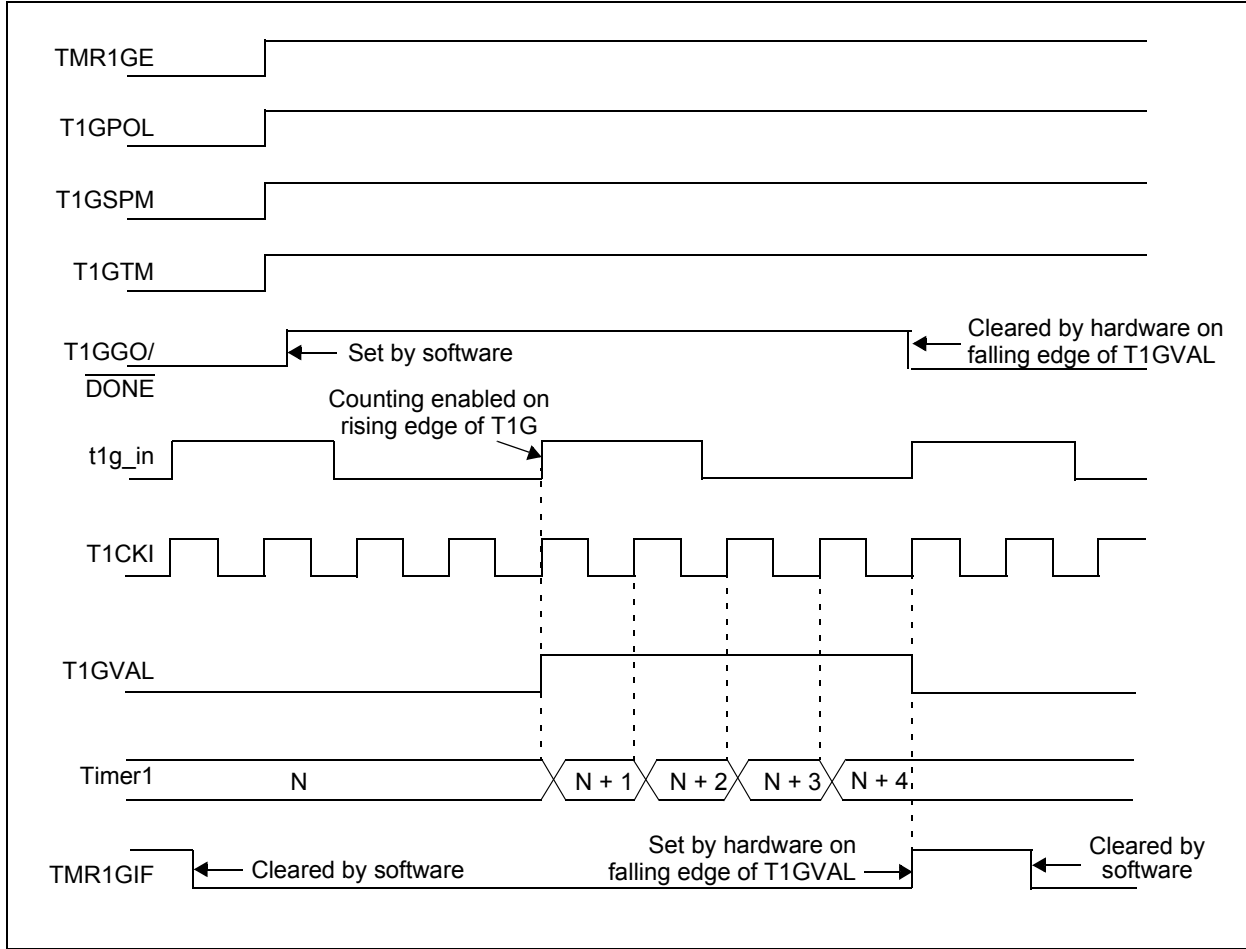


**FIGURE 27-5: TIMER1 GATE SINGLE-PULSE MODE**



# PIC16(L)F1717/8/9

**FIGURE 27-6: TIMER1 GATE SINGLE-PULSE AND TOGGLE COMBINED MODE**



## 27.11 Register Definitions: Timer1 Control

### REGISTER 27-1: T1CON: TIMER1 CONTROL REGISTER

R/W-0/u	R/W-0/u	R/W-0/u	R/W-0/u	R/W-0/u	R/W-0/u	U-0	R/W-0/u
TMR1CS<1:0>		T1CKPS<1:0>		T1OSCEN	$\overline{T1SYNC}$	—	TMR1ON
bit 7							bit 0

#### Legend:

R = Readable bit	W = Writable bit	U = Unimplemented bit, read as '0'
u = Bit is unchanged	x = Bit is unknown	-n/n = Value at POR and BOR/Value at all other Resets
'1' = Bit is set	'0' = Bit is cleared	

- bit 7-6     **TMR1CS<1:0>**: Timer1 Clock Source Select bits  
 11 = LFINTOSC  
 10 = Timer1 clock source is pin or oscillator:  
     If **T1OSCEN** = 0:  
     External clock from T1CKI pin (on the rising edge)  
     If **T1OSCEN** = 1:  
     Crystal oscillator on SOSC1/SOSCO pins  
 01 = Timer1 clock source is system clock (Fosc)  
 00 = Timer1 clock source is instruction clock (Fosc/4)
- bit 5-4     **T1CKPS<1:0>**: Timer1 Input Clock Prescale Select bits  
 11 = 1:8 Prescale value  
 10 = 1:4 Prescale value  
 01 = 1:2 Prescale value  
 00 = 1:1 Prescale value
- bit 3       **T1OSCEN**: LP Oscillator Enable Control bit  
 1 = Dedicated secondary oscillator circuit enabled  
 0 = Dedicated secondary oscillator circuit disabled
- bit 2        **$\overline{T1SYNC}$** : Timer1 Synchronization Control bit  
 1 = Do not synchronize asynchronous clock input  
 0 = Synchronize asynchronous clock input with system clock (Fosc)
- bit 1       **Unimplemented**: Read as '0'
- bit 0       **TMR1ON**: Timer1 On bit  
 1 = Enables Timer1  
 0 = Stops Timer1 and clears Timer1 gate flip-flop

# PIC16(L)F1717/8/9

## REGISTER 27-2: T1GCON: TIMER1 GATE CONTROL REGISTER

R/W-0/u	R/W-0/u	R/W-0/u	R/W-0/u	R/W/HC-0/u	R-x/x	R/W-0/u	R/W-0/u
TMR1GE	T1GPOL	T1GTM	T1GSPM	T1GGO/ DONE	T1GVAL	T1GSS<1:0>	
bit 7						bit 0	

### Legend:

R = Readable bit	W = Writable bit	U = Unimplemented bit, read as '0'
u = Bit is unchanged	x = Bit is unknown	-n/n = Value at POR and BOR/Value at all other Resets
'1' = Bit is set	'0' = Bit is cleared	HC = Bit is cleared by hardware

- bit 7      **TMR1GE:** Timer1 Gate Enable bit  
If TMR1ON = 0:  
This bit is ignored  
If TMR1ON = 1:  
1 = Timer1 counting is controlled by the Timer1 gate function  
0 = Timer1 counts regardless of Timer1 gate function
- bit 6      **T1GPOL:** Timer1 Gate Polarity bit  
1 = Timer1 gate is active-high (Timer1 counts when gate is high)  
0 = Timer1 gate is active-low (Timer1 counts when gate is low)
- bit 5      **T1GTM:** Timer1 Gate Toggle Mode bit  
1 = Timer1 Gate Toggle mode is enabled  
0 = Timer1 Gate Toggle mode is disabled and toggle flip-flop is cleared  
Timer1 gate flip-flop toggles on every rising edge.
- bit 4      **T1GSPM:** Timer1 Gate Single-Pulse Mode bit  
1 = Timer1 Gate Single-Pulse mode is enabled and is controlling Timer1 gate  
0 = Timer1 Gate Single-Pulse mode is disabled
- bit 3      **T1GGO/DONE:** Timer1 Gate Single-Pulse Acquisition Status bit  
1 = Timer1 gate single-pulse acquisition is ready, waiting for an edge  
0 = Timer1 gate single-pulse acquisition has completed or has not been started
- bit 2      **T1GVAL:** Timer1 Gate Value Status bit  
Indicates the current state of the Timer1 gate that could be provided to TMR1H:TMR1L  
Unaffected by Timer1 Gate Enable (TMR1GE)
- bit 1-0    **T1GSS<1:0>:** Timer1 Gate Source Select bits  
11 = Comparator 2 optionally synchronized output (sync\_C2OUT)  
10 = Comparator 1 optionally synchronized output (sync\_C1OUT)  
01 = Timer0 overflow output  
00 = Timer1 gate pin



**TABLE 27-5: SUMMARY OF REGISTERS ASSOCIATED WITH TIMER1**

Name	Bit 7	Bit 6	Bit 5	Bit 4	Bit 3	Bit 2	Bit 1	Bit 0	Register on Page
ANSELA	—	—	ANSA5	ANSA4	ANSA3	ANSA2	ANSA1	ANSA0	125
ANSELB	—	—	ANSB5	ANSB4	ANSB3	ANSB2	ANSB1	ANSB0	131
ANSELC	ANSC7	ANSC6	ANSC5	ANSC4	ANSC3	ANSC2	—	—	136
CCP1CON	—	—	DC1B<1:0>		CCP1M<3:0>				294
CCP2CON	—	—	DC2B<1:0>		CCP2M<3:0>				294
INTCON	GIE	PEIE	TMR0IE	INTE	IOIE	TMR0IF	INTF	IOCF	90
PIE1	TMR1GIE	ADIE	RCIE	TXIE	SSP1IE	CCP1IE	TMR2IE	TMR1IE	91
PIR1	TMR1GIF	ADIF	RCIF	TXIF	SSP1IF	CCP1IF	TMR2IF	TMR1IF	94
TMR1H	Holding Register for the Most Significant Byte of the 16-bit TMR1 Register								271*
TMR1L	Holding Register for the Least Significant Byte of the 16-bit TMR1 Register								271*
TRISA	TRISA7	TRISA6	TRISA5	TRISA4	TRISA3	TRISA2	TRISA1	TRISA0	124
TRISB	TRISB7	TRISB6	TRISB5	TRISB4	TRISB3	TRISB2	TRISB1	TRISB0	130
TRISC	TRISC7	TRISC6	TRISC5	TRISC4	TRISC3	TRISC2	TRISC1	TRISC0	135
T1CON	TMR1CS<1:0>		T1CKPS<1:0>		T1OSCEN	T1SYNC	—	TMR1ON	279
T1GCON	TMR1GE	T1GPOL	T1GTM	T1GSPM	T1GGO/ DONE	T1GVAL	T1GSS<1:0>		280

**Legend:** — = unimplemented location, read as '0'. Shaded cells are not used by the Timer1 module.

\* Page provides register information.

# PIC16(L)F1717/8/9

## 28.0 TIMER2/4/6 MODULE

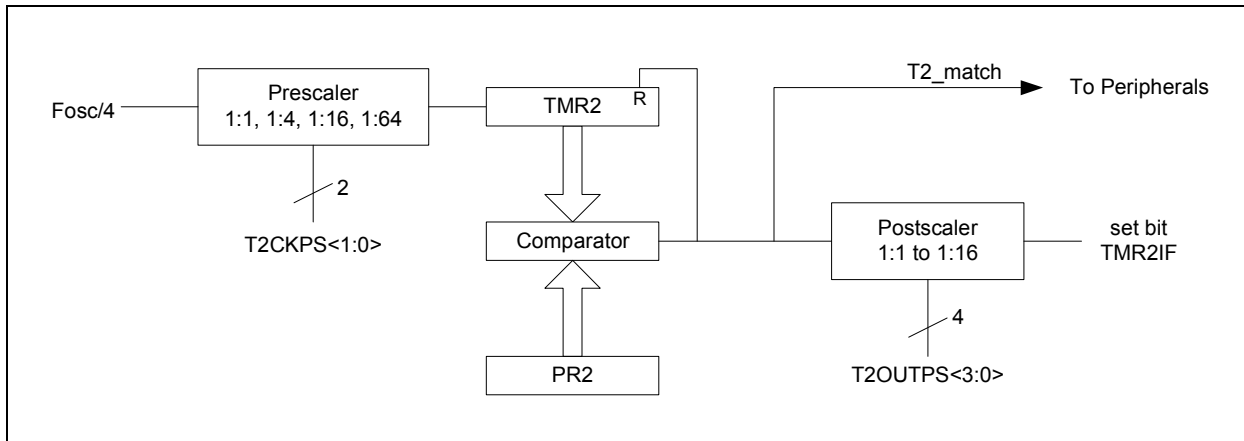
The Timer2/4/6 modules are 8-bit timers that incorporate the following features:

- 8-bit Timer and Period registers (TMR2 and PR2, respectively)
- Readable and writable (both registers)
- Software programmable prescaler (1:1, 1:4, 1:16, and 1:64)
- Software programmable postscaler (1:1 to 1:16)
- Interrupt on TMR2 match with PR2, respectively
- Optional use as the shift clock for the MSSP module

See Figure 28-1 for a block diagram of Timer2.

Three identical Timer2 modules are implemented on this device. To maintain consistency with earlier devices, the timers are named Timer2, Timer4, and Timer6. All references to Timer2 apply as well to Timer4 and Timer6.

**FIGURE 28-1: TIMER2 BLOCK DIAGRAM**



## 28.1 Timer2 Operation

The clock input to the Timer2 modules is the system instruction clock ( $F_{osc}/4$ ).

TMR2 increments from 00h on each clock edge.

A 4-bit counter/prescaler on the clock input allows direct input, divide-by-4 and divide-by-16 prescale options. These options are selected by the prescaler control bits, T2CKPS<1:0> of the T2CON register. The value of TMR2 is compared to that of the Period register, PR2, on each clock cycle. When the two values match, the comparator generates a match signal as the timer output. This signal also resets the value of TMR2 to 00h on the next cycle and drives the output counter/postscaler (see [Section 28.2 “Timer2 Interrupt”](#)).

The TMR2 and PR2 registers are both directly readable and writable. The TMR2 register is cleared on any device Reset, whereas the PR2 register initializes to FFh. Both the prescaler and postscaler counters are cleared on the following events:

- A write to the TMR2 register
- A write to the T2CON register
- Power-on Reset (POR)
- Brown-out Reset (BOR)
- MCLR Reset
- Watchdog Timer (WDT) Reset
- Stack Overflow Reset
- Stack Underflow Reset
- RESET Instruction

<b>Note:</b> TMR2 is not cleared when T2CON is written.
---

## 28.2 Timer2 Interrupt

Timer2 can also generate an optional device interrupt. The Timer2 output signal (TMR2-to-PR2 match) provides the input for the 4-bit counter/postscaler. This counter generates the TMR2 match interrupt flag which is latched in TMR2IF of the PIR1 register. The interrupt is enabled by setting the TMR2 Match Interrupt Enable bit, TMR2IE, of the PIE1 register.

A range of 16 postscale options (from 1:1 through 1:16 inclusive) can be selected with the postscaler control bits, T2OUTPS<3:0>, of the T2CON register.

## 28.3 Timer2 Output

The unscaled output of TMR2 is available primarily to the CCP modules, where it is used as a time base for operations in PWM mode.

Timer2 can be optionally used as the shift clock source for the MSSP module operating in SPI mode. Additional information is provided in [Section 30.0 “Master Synchronous Serial Port \(MSSP\) Module”](#).

## 28.4 Timer2 Operation During Sleep

The Timer2 timers cannot be operated while the processor is in Sleep mode. The contents of the TMR2 and PR2 registers will remain unchanged while the processor is in Sleep mode.

# PIC16(L)F1717/8/9

## 28.5 Register Definitions: Timer2 Control

### REGISTER 28-1: T2CON: TIMER2 CONTROL REGISTER

U-0	R/W-0/0	R/W-0/0	R/W-0/0	R/W-0/0	R/W-0/0	R/W-0/0	R/W-0/0
—	T2OUTPS<3:0>				TMR2ON	T2CKPS<1:0>	
bit 7							bit 0

#### Legend:

R = Readable bit	W = Writable bit	U = Unimplemented bit, read as '0'
u = Bit is unchanged	x = Bit is unknown	-n/n = Value at POR and BOR/Value at all other Resets
'1' = Bit is set	'0' = Bit is cleared	

bit 7	<b>Unimplemented:</b> Read as '0'
bit 6-3	<b>T2OUTPS&lt;3:0&gt;:</b> Timer2 Output Postscaler Select bits 1111 = 1:16 Postscaler 1110 = 1:15 Postscaler 1101 = 1:14 Postscaler 1100 = 1:13 Postscaler 1011 = 1:12 Postscaler 1010 = 1:11 Postscaler 1001 = 1:10 Postscaler 1000 = 1:9 Postscaler 0111 = 1:8 Postscaler 0110 = 1:7 Postscaler 0101 = 1:6 Postscaler 0100 = 1:5 Postscaler 0011 = 1:4 Postscaler 0010 = 1:3 Postscaler 0001 = 1:2 Postscaler 0000 = 1:1 Postscaler
bit 2	<b>TMR2ON:</b> Timer2 On bit 1 = Timer2 is on 0 = Timer2 is off
bit 1-0	<b>T2CKPS&lt;1:0&gt;:</b> Timer2 Clock Prescale Select bits 11 = Prescaler is 64 10 = Prescaler is 16 01 = Prescaler is 4 00 = Prescaler is 1

**TABLE 28-1: SUMMARY OF REGISTERS ASSOCIATED WITH TIMER2**

Name	Bit 7	Bit 6	Bit 5	Bit 4	Bit 3	Bit 2	Bit 1	Bit 0	Register on Page
CCP2CON	—	—	DC2B<1:0>		CCP2M<3:0>				294
INTCON	GIE	PEIE	TMR0IE	INTE	IOCIE	TMR0IF	INTF	IOCIF	90
PIE1	TMR1GIE	ADIE	RCIE	TXIE	SSP1IE	CCP1IE	TMR2IE	TMR1IE	91
PIR1	TMR1GIF	ADIF	RCIF	TXIF	SSP1IF	CCP1IF	TMR2IF	TMR1IF	94
PR2	Timer2 Module Period Register								282*
T2CON	—	T2OUTPS<3:0>				TMR2ON	T2CKPS<1:0>		284
TMR2	Holding Register for the 8-bit TMR2 Register								282*

**Legend:** — = unimplemented location, read as '0'. Shaded cells are not used for Timer2 module.

\* Page provides register information.

# PIC16(L)F1717/8/9

## 28.6 CCP/PWM Clock Selection

The PIC16(L)F1717/8/9 allows each individual CCP and PWM module to select the timer source that controls the module. Each module has an independent selection.

As there are up to three 8-bit timers with auto-reload (Timer2, Timer4, and Timer6), PWM mode on the CCP and PWM modules can use any of these timers.

The CCPTMRS register is used to select which timer is used.

## 28.7 Register Definitions: CCP/PWM Timers Control

### REGISTER 28-2: CCPTMRS: PWM TIMER SELECTION CONTROL REGISTER 0

R/W-0/0	R/W-0/0	R/W-0/0	R/W-0/0	R/W-0/0	R/W-0/0	R/W-0/0	R/W-0/0
P4TSEL<1:0>		P3TSEL<1:0>		C2TSEL<1:0>		C1TSEL<1:0>	
bit 7							bit 0

#### Legend:

R = Readable bit

W = Writable bit

U = Unimplemented bit, read as '0'

u = Bit is unchanged

x = Bit is unknown

-n/n = Value at POR and BOR/Value at all other Resets

'1' = Bit is set

'0' = Bit is cleared

- bit 7-6      **P4TSEL<1:0>**: PWM4 Timer Selection  
11 = Reserved  
10 = PWM4 is based off Timer6  
01 = PWM4 is based off Timer4  
00 = PWM4 is based off Timer2
- bit 5-4      **P3TSEL<1:0>**: PWM3 Timer Selection  
11 = Reserved  
10 = PWM3 is based off Timer6  
01 = PWM3 is based off Timer4  
00 = PWM3 is based off Timer2
- bit 3-2      **C2TSEL<1:0>**: CCP2 (PWM2) Timer Selection  
11 = Reserved  
10 = CCP2 is based off Timer 6 in PWM mode  
01 = CCP2 is based off Timer 4 in PWM mode  
00 = CCP2 is based off Timer 2 in PWM mode
- bit 1-0      **C1TSEL<1:0>**: CCP1 (PWM1) Timer Selection  
11 = Reserved  
10 = CCP1 is based off Timer6 in PWM mode  
01 = CCP1 is based off Timer4 in PWM mode  
00 = CCP1 is based off Timer2 in PWM mode

## 29.0 CAPTURE/COMPARE/PWM MODULES

The Capture/Compare/PWM module is a peripheral which allows the user to time and control different events, and to generate Pulse-Width Modulation (PWM) signals. In Capture mode, the peripheral allows the timing of the duration of an event. The Compare mode allows the user to trigger an external event when a predetermined amount of time has expired. The PWM mode can generate Pulse-Width Modulated signals of varying frequency and duty cycle.

This family of devices contains two standard Capture/Compare/PWM modules (CCP1 and CCP2).

The Capture and Compare functions are identical for all CCP modules.

**Note 1:** In devices with more than one CCP module, it is very important to pay close attention to the register names used. A number placed after the module acronym is used to distinguish between separate modules. For example, the CCP1CON and CCP2CON control the same operational aspects of two completely different CCP modules.

**2:** Throughout this section, generic references to a CCP module in any of its operating modes may be interpreted as being equally applicable to CCPx module. Register names, module signals, I/O pins, and bit names may use the generic designator 'x' to indicate the use of a numeral to distinguish a particular module, when required.

## 29.1 Capture Mode

The Capture mode function described in this section is available and identical for all CCP modules.

Capture mode makes use of the 16-bit Timer1 resource. When an event occurs on the CCPx pin, the 16-bit CCPRxH:CCPRxL register pair captures and stores the 16-bit value of the TMR1H:TMR1L register pair, respectively. An event is defined as one of the following and is configured by the CCPxM<3:0> bits of the CCPxCON register:

- Every falling edge
- Every rising edge
- Every 4th rising edge
- Every 16th rising edge

When a capture is made, the Interrupt Request Flag bit CCPxIF of the PIRx register is set. The interrupt flag must be cleared in software. If another capture occurs before the value in the CCPRxH, CCPRxL register pair is read, the old captured value is overwritten by the new captured value.

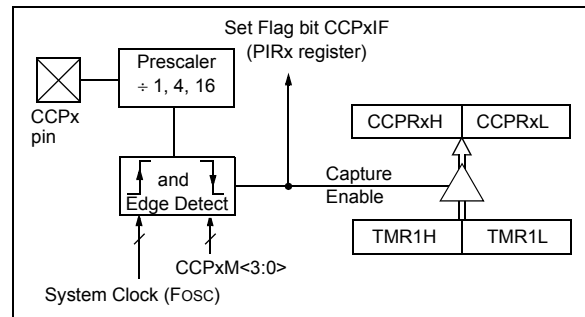
Figure 29-1 shows a simplified diagram of the capture operation.

### 29.1.1 CCP PIN CONFIGURATION

In Capture mode, the CCPx pin should be configured as an input by setting the associated TRIS control bit.

**Note:** If the CCPx pin is configured as an output, a write to the port can cause a capture condition.

**FIGURE 29-1: CAPTURE MODE OPERATION BLOCK DIAGRAM**



# PIC16(L)F1717/8/9

## 29.1.2 TIMER1 MODE RESOURCE

Timer1 must be running in Timer mode or Synchronized Counter mode for the CCP module to use the capture feature. In Asynchronous Counter mode, the capture operation may not work.

See [Section 27.0 “Timer1 Module with Gate Control”](#) for more information on configuring Timer1.

## 29.1.3 SOFTWARE INTERRUPT MODE

When the Capture mode is changed, a false capture interrupt may be generated. The user should keep the CCPxIE interrupt enable bit of the PIEx register clear to avoid false interrupts. Additionally, the user should clear the CCPxIF interrupt flag bit of the PIRx register following any change in Operating mode.

**Note:** Clocking Timer1 from the system clock (FOSC) should not be used in Capture mode. In order for Capture mode to recognize the trigger event on the CCPx pin, Timer1 must be clocked from the instruction clock (FOSC/4) or from an external clock source.

## 29.1.4 CCP PRESCALER

There are four prescaler settings specified by the CCPxM<3:0> bits of the CCPxCON register. Whenever the CCP module is turned off, or the CCP module is not in Capture mode, the prescaler counter is cleared. Any Reset will clear the prescaler counter.

Switching from one capture prescaler to another does not clear the prescaler and may generate a false interrupt. To avoid this unexpected operation, turn the module off by clearing the CCPxCON register before changing the prescaler. [Example 29-1](#) demonstrates the code to perform this function.

### EXAMPLE 29-1: CHANGING BETWEEN CAPTURE PRESCALERS

```
BANKSEL CCPxCON    ;Set Bank bits to point
                   ;to CCPxCON
CLRWF  CCPxCON     ;Turn CCP module off
MOVLW  NEW_CAPT_PS ;Load the W reg with
                   ;the new prescaler
                   ;move value and CCP ON
MOVWF  CCPxCON     ;Load CCPxCON with this
                   ;value
```

## 29.1.5 CAPTURE DURING SLEEP

Capture mode depends upon the Timer1 module for proper operation. There are two options for driving the Timer1 module in Capture mode. It can be driven by the instruction clock (FOSC/4), or by an external clock source.

When Timer1 is clocked by FOSC/4, Timer1 will not increment during Sleep. When the device wakes from Sleep, Timer1 will continue from its previous state.

Capture mode will operate during Sleep when Timer1 is clocked by an external clock source.



## 29.2 Compare Mode

The Compare mode function described in this section is available and identical for all CCP modules.

Compare mode makes use of the 16-bit Timer1 resource. The 16-bit value of the CCPRxH:CCPRxL register pair is constantly compared against the 16-bit value of the TMR1H:TMR1L register pair. When a match occurs, one of the following events can occur:

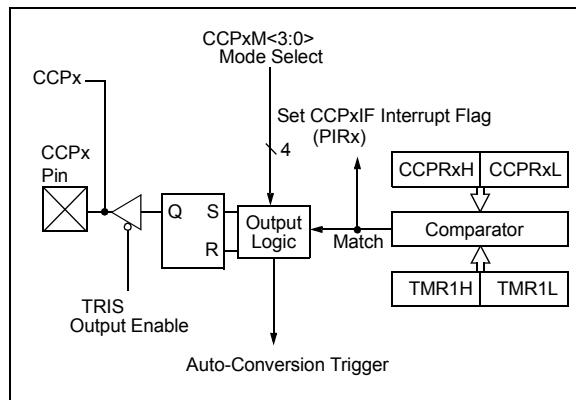
- Toggle the CCPx output
- Set the CCPx output
- Clear the CCPx output
- Generate an Auto-conversion Trigger
- Generate a Software Interrupt

The action on the pin is based on the value of the CCPxM<3:0> control bits of the CCPxCON register. At the same time, the interrupt flag CCPxIF bit is set.

All Compare modes can generate an interrupt.

Figure 29-2 shows a simplified diagram of the compare operation.

**FIGURE 29-2: COMPARE MODE OPERATION BLOCK DIAGRAM**



### 29.2.1 CCPX PIN CONFIGURATION

The user must configure the CCPx pin as an output by clearing the associated TRIS bit.

**Note:** Clearing the CCPxCON register will force the CCPx compare output latch to the default low level. This is not the PORT I/O data latch.

### 29.2.2 TIMER1 MODE RESOURCE

In Compare mode, Timer1 must be running in either Timer mode or Synchronized Counter mode. The compare operation may not work in Asynchronous Counter mode.

See [Section 27.0 “Timer1 Module with Gate Control”](#) for more information on configuring Timer1.

**Note:** Clocking Timer1 from the system clock (FOSC) should not be used in Compare mode. In order for Compare mode to recognize the trigger event on the CCPx pin, Timer1 must be clocked from the instruction clock (FOSC/4) or from an external clock source.

### 29.2.3 SOFTWARE INTERRUPT MODE

When Generate Software Interrupt mode is chosen (CCPxM<3:0> = 1010), the CCPx module does not assert control of the CCPx pin (see the CCPxCON register).

### 29.2.4 AUTO-CONVERSION TRIGGER

When Auto-Conversion Trigger mode is chosen (CCPxM<3:0> = 1011), the CCPx module does the following:

- Resets Timer1
- Starts an ADC conversion if ADC is enabled

The CCPx module does not assert control of the CCPx pin in this mode.

The auto-conversion trigger output of the CCP occurs immediately upon a match between the TMR1H, TMR1L register pair and the CCPRxH, CCPRxL register pair. The TMR1H, TMR1L register pair is not reset until the next rising edge of the Timer1 clock. The auto-conversion trigger output starts an ADC conversion (if the ADC module is enabled). This allows the CCPRxH, CCPRxL register pair to effectively provide a 16-bit programmable period register for Timer1.

Refer to [Section 29.2.4 “Auto-Conversion Trigger”](#) for more information.

**Note 1:** The auto-conversion trigger from the CCP module does not set interrupt flag bit TMR1IF of the PIR1 register.

**2:** Removing the match condition by changing the contents of the CCPRxH and CCPRxL register pair, between the clock edge that generates the auto-conversion trigger and the clock edge that generates the Timer1 Reset, will preclude the Reset from occurring.

### 29.2.5 COMPARE DURING SLEEP

The Compare mode is dependent upon the system clock (FOSC) for proper operation. Since FOSC is shut down during Sleep mode, the Compare mode will not function properly during Sleep.

# PIC16(L)F1717/8/9

## 29.3 PWM Overview

Pulse-Width Modulation (PWM) is a scheme that provides power to a load by switching quickly between fully on and fully off states. The PWM signal resembles a square wave where the high portion of the signal is considered the on state and the low portion of the signal is considered the off state. The high portion, also known as the pulse width, can vary in time and is defined in steps. A larger number of steps applied, which lengthens the pulse width, also supplies more power to the load. Lowering the number of steps applied, which shortens the pulse width, supplies less power. The PWM period is defined as the duration of one complete cycle or the total amount of on and off time combined.

PWM resolution defines the maximum number of steps that can be present in a single PWM period. A higher resolution allows for more precise control of the pulse width time and in turn the power that is applied to the load.

The term duty cycle describes the proportion of the on time to the off time and is expressed in percentages, where 0% is fully off and 100% is fully on. A lower duty cycle corresponds to less power applied and a higher duty cycle corresponds to more power applied.

Figure 29-3 shows a typical waveform of the PWM signal.

### 29.3.1 STANDARD PWM OPERATION

The standard PWM function described in this section is available and identical for all CCP modules.

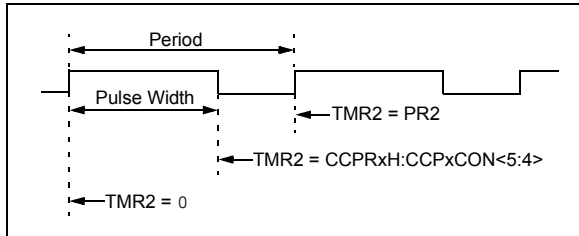
The standard PWM mode generates a Pulse-Width Modulation (PWM) signal on the CCPx pin with up to ten bits of resolution. The period, duty cycle, and resolution are controlled by the following registers:

- PR2 registers
- T2CON registers
- CCPRxL registers
- CCPxCON registers

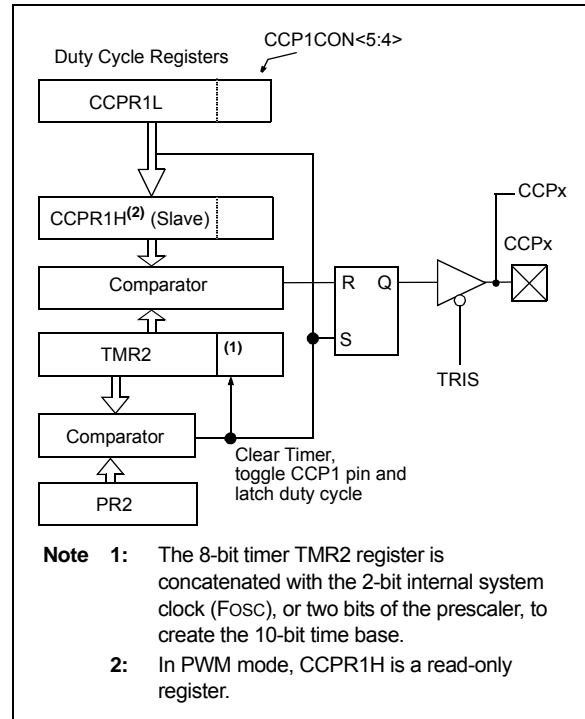
Figure 29-4 shows a simplified block diagram of PWM operation.

**Note:** The corresponding TRIS bit must be cleared to enable the PWM output on the CCPx pin.

**FIGURE 29-3: CCP PWM OUTPUT SIGNAL**



**FIGURE 29-4: SIMPLIFIED PWM BLOCK DIAGRAM**



## 29.3.2 SETUP FOR PWM OPERATION

The following steps should be taken when configuring the CCP module for standard PWM operation:

1. Use the desired output pin RxyPPS control to select CCPx as the source and disable the CCPx pin output driver by setting the associated TRIS bit.
2. Load the PR2 register with the PWM period value.
3. Configure the CCP module for the PWM mode by loading the CCPxCON register with the appropriate values.
4. Load the CCPRxL register and the DCxBx bits of the CCPxCON register, with the PWM duty cycle value.
5. Configure and start Timer2:
  - Clear the TMR2IF interrupt flag bit of the PIRx register. See Note below.
  - Configure the T2CKPS bits of the T2CON register with the Timer prescale value.
  - Enable the Timer by setting the TMR2ON bit of the T2CON register.
6. Enable PWM output pin:
  - Wait until the Timer overflows and the TMR2IF bit of the PIR1 register is set. See Note below.
  - Enable the CCPx pin output driver by clearing the associated TRIS bit.

**Note:** In order to send a complete duty cycle and period on the first PWM output, the above steps must be included in the setup sequence. If it is not critical to start with a complete PWM signal on the first output, then step 6 may be ignored.

## 29.3.3 TIMER2 TIMER RESOURCE

The PWM standard mode makes use of the 8-bit Timer2 timer resources to specify the PWM period.

## 29.3.4 PWM PERIOD

The PWM period is specified by the PR2 register of Timer2. The PWM period can be calculated using the formula of [Equation 29-1](#).

### EQUATION 29-1: PWM PERIOD

$$PWM\ Period = [(PR2) + 1] \cdot 4 \cdot T_{OSC} \cdot (TMR2\ Prescale\ Value)$$

**Note 1:**  $T_{OSC} = 1/F_{OSC}$

When TMR2 is equal to PR2, the following three events occur on the next increment cycle:

- TMR2 is cleared
- The CCPx pin is set. (Exception: If the PWM duty cycle = 0%, the pin will not be set.)
- The PWM duty cycle is latched from CCPRxL into CCPRxH

**Note:** The Timer postscaler (see [Section 28.1 "Timer2 Operation"](#)) is not used in the determination of the PWM frequency.

## 29.3.5 PWM DUTY CYCLE

The PWM duty cycle is specified by writing a 10-bit value to multiple registers: CCPRxL register and DCxB<1:0> bits of the CCPxCON register. The CCPRxL contains the eight MSBs and the DCxB<1:0> bits of the CCPxCON register contain the two LSBs. CCPRxL and DCxB<1:0> bits of the CCPxCON register can be written to at any time. The duty cycle value is not latched into CCPRxH until after the period completes (i.e., a match between PR2 and TMR2 registers occurs). While using the PWM, the CCPRxH register is read-only.

[Equation 29-2](#) is used to calculate the PWM pulse width.

[Equation 29-3](#) is used to calculate the PWM duty cycle ratio.

### EQUATION 29-2: PULSE WIDTH

$$Pulse\ Width = (CCPRxL:CCPxCON<5:4>) \cdot T_{OSC} \cdot (TMR2\ Prescale\ Value)$$

### EQUATION 29-3: DUTY CYCLE RATIO

$$Duty\ Cycle\ Ratio = \frac{(CCPRxL:CCPxCON<5:4>)}{4(PR2 + 1)}$$

The CCPRxH register and a 2-bit internal latch are used to double buffer the PWM duty cycle. This double buffering is essential for glitchless PWM operation.

# PIC16(L)F1717/8/9

The 8-bit timer TMR2 register is concatenated with either the 2-bit internal system clock (FOSC), or two bits of the prescaler, to create the 10-bit time base. The system clock is used if the Timer2 prescaler is set to 1:1.

When the 10-bit time base matches the CCPRxH and 2-bit latch, then the CCPx pin is cleared (see [Figure 29-4](#)).

## 29.3.6 PWM RESOLUTION

The resolution determines the number of available duty cycles for a given period. For example, a 10-bit resolution will result in 1024 discrete duty cycles, whereas an 8-bit resolution will result in 256 discrete duty cycles.

The maximum PWM resolution is 10 bits when PR2 is 255. The resolution is a function of the PR2 register value as shown by [Equation 29-4](#).

### EQUATION 29-4: PWM RESOLUTION

$$Resolution = \frac{\log[4(PR2 + 1)]}{\log(2)} \text{ bits}$$

**Note:** If the pulse width value is greater than the period, the assigned PWM pin(s) will remain unchanged.

**TABLE 29-1: EXAMPLE PWM FREQUENCIES AND RESOLUTIONS (Fosc = 20 MHz)**

PWM Frequency	1.22 kHz	4.88 kHz	19.53 kHz	78.12 kHz	156.3 kHz	208.3 kHz
Timer Prescale	16	4	1	1	1	1
PR2 Value	0xFF	0xFF	0xFF	0x3F	0x1F	0x17
Maximum Resolution (bits)	10	10	10	8	7	6.6

**TABLE 29-2: EXAMPLE PWM FREQUENCIES AND RESOLUTIONS (Fosc = 8 MHz)**

PWM Frequency	1.22 kHz	4.90 kHz	19.61 kHz	76.92 kHz	153.85 kHz	200.0 kHz
Timer Prescale	16	4	1	1	1	1
PR2 Value	0x65	0x65	0x65	0x19	0x0C	0x09
Maximum Resolution (bits)	8	8	8	6	5	5

## 29.3.7 OPERATION IN SLEEP MODE

In Sleep mode, the TMR2 register will not increment and the state of the module will not change. If the CCPx pin is driving a value, it will continue to drive that value. When the device wakes up, TMR2 will continue from its previous state.

## 29.3.8 CHANGES IN SYSTEM CLOCK FREQUENCY

The PWM frequency is derived from the system clock frequency. Any changes in the system clock frequency will result in changes to the PWM frequency. See [Section 6.0 “Oscillator Module \(with Fail-Safe Clock Monitor\)”](#) for additional details.

## 29.3.9 EFFECTS OF RESET

Any Reset will force all ports to Input mode and the CCP registers to their Reset states.

**TABLE 29-3: SUMMARY OF REGISTERS ASSOCIATED WITH CCP**

Name	Bit 7	Bit 6	Bit 5	Bit 4	Bit 3	Bit 2	Bit 1	Bit 0	Register on Page
CCP1CON	—	—	DC1B<1:0>		CCP1M<3:0>				294
CCPR1L	Capture/Compare/PWM Register 1 (LSB)								291*
CCPTMRS	P4TSEL<1:0>		P3TSEL<1:0>		C2TSEL<1:0>		C1TSEL<1:0>		286
INTCON	GIE	PEIE	TMR0IE	INTE	IOCFIE	TMR0IF	INTF	IOCFIF	90
PIE1	TMR1GIE	ADIE	RCIE	TXIE	SSP1IE	CCP1IE	TMR2IE	TMR1IE	91
PIE2	OSFIE	C2IE	C1IE	—	BCL1IE	TMR6IE	TMR4IE	CCP2IE	92
PIR1	TMR1GIF	ADIF	RCIF	TXIF	SSP1IF	CCP1IF	TMR2IF	TMR1IF	94
PIR2	OSFIF	C2IF	C1IF	—	BCL1IF	TMR6IF	TMR4IF	CCP2IF	95
PR2	Timer2 Period Register								282*
ANSELB	—	—	ANSB5	ANSB4	ANSB3	ANSB2	ANSB1	ANSB0	131
ANSELC	ANSC7	ANSC6	ANSC5	ANSC4	ANSC3	ANSC2	—	—	136
TRISB	TRISB7	TRISB6	TRISB5	TRISB4	TRISB3	TRISB2	TRISB1	TRISB0	130
TRISC	TRISC7	TRISC6	TRISC5	TRISC4	TRISC3	TRISC2	TRISC1	TRISC0	135
RxyPPS	—	—	—	RxyPPS<4:0>					153
CCP1PPS	—	—	—	CCP1PPS<4:0>					152
CCP2PPS	—	—	—	CCP2PPS<4:0>					152
T2CON	—	T2OUTPS<3:0>				TMR2ON	T2CKPS<1:0>		284
TMR2	Timer2 Module Register								282

**Legend:** — = Unimplemented location, read as '0'. Shaded cells are not used by the CCP.

\* Page provides register information.

# PIC16(L)F1717/8/9

## 29.4 Register Definitions: CCP Control

### REGISTER 29-1: CCPxCON: CCPx CONTROL REGISTER

U-0	U-0	R/W-0/0	R/W-0/0	R/W-0/0	R/W-0/0	R/W-0/0	R/W-0/0
—	—	DCxB<1:0>		CCPxM<3:0>			
bit 7							bit 0

#### Legend:

R = Readable bit	W = Writable bit	U = Unimplemented bit, read as '0'
u = Bit is unchanged	x = Bit is unknown	-n/n = Value at POR and BOR/Value at all other Reset
'1' = Bit is set	'0' = Bit is cleared	

bit 7-6 **Unimplemented:** Read as '0'

bit 5-4 **DCxB<1:0>:** PWM Duty Cycle Least Significant bits

Capture mode:

Unused

Compare mode:

Unused

PWM mode:

These bits are the two LSbs of the PWM duty cycle. The eight MSbs are found in CCPRxL.

bit 3-0 **CCPxM<3:0>:** CCPx Mode Select bits

11xx = PWM mode

1011 = Compare mode: Auto-conversion Trigger (sets CCPxIF bit), starts ADC conversion if TRIGSEL = CCPx (see [Register 21-3](#))

1010 = Compare mode: generate software interrupt only

1001 = Compare mode: clear output on compare match (set CCPxIF)

1000 = Compare mode: set output on compare match (set CCPxIF)

0111 = Capture mode: every 16th rising edge

0110 = Capture mode: every 4th rising edge

0101 = Capture mode: every rising edge

0100 = Capture mode: every falling edge

0011 = Reserved

0010 = Compare mode: toggle output on match

0001 = Reserved

0000 = Capture/Compare/PWM off (resets CCPx module)



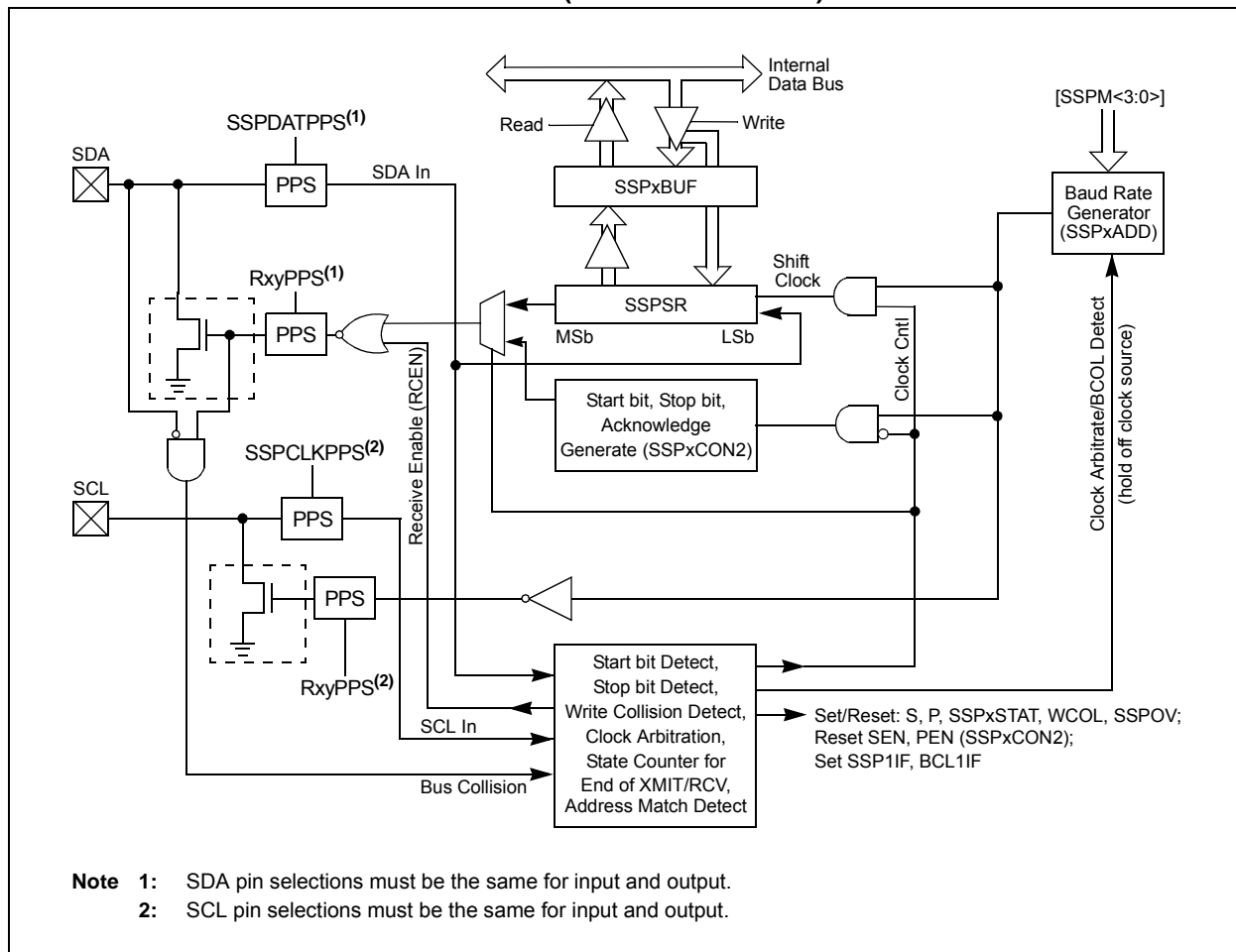
# PIC16(L)F1717/8/9

The I<sup>2</sup>C interface supports the following modes and features:

- Master mode
- Slave mode
- Byte NACKing (Slave mode)
- Limited multi-master support
- 7-bit and 10-bit addressing
- Start and Stop interrupts
- Interrupt masking
- Clock stretching
- Bus collision detection
- General call address matching
- Address masking
- Address Hold and Data Hold modes
- Selectable SDA hold times

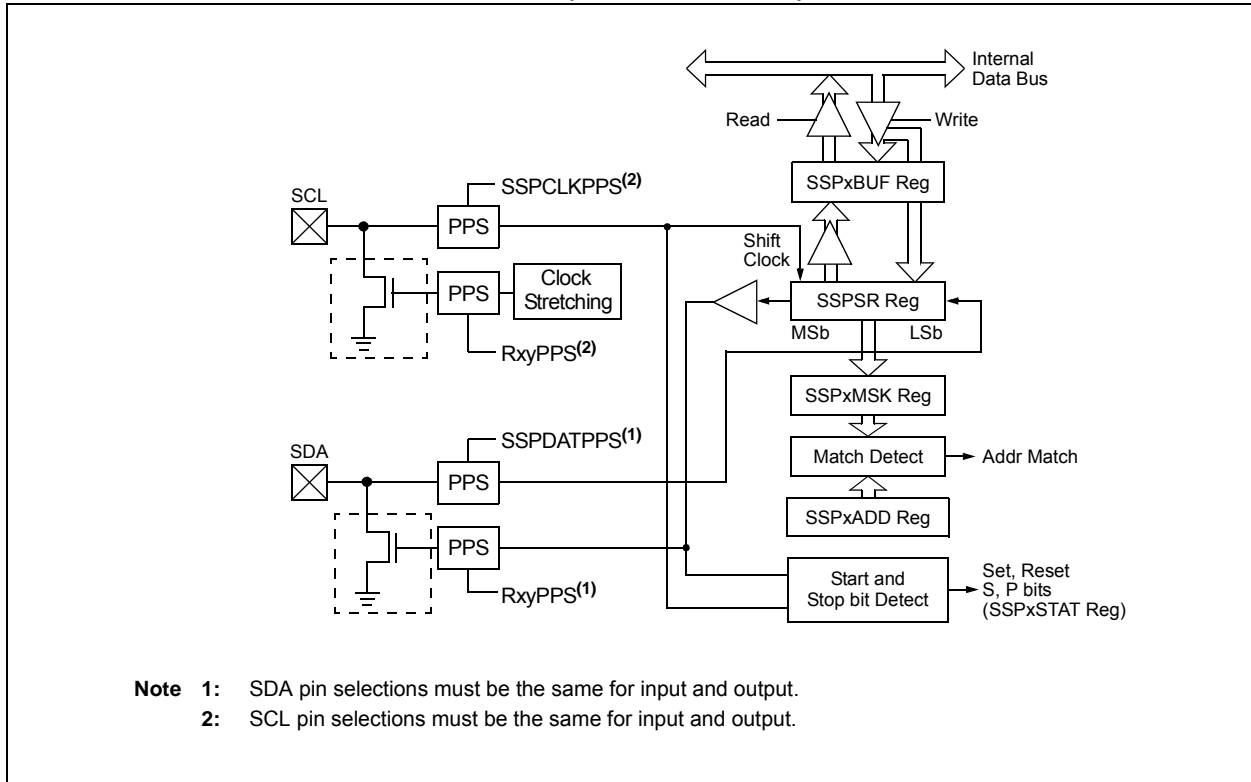
Figure 30-2 is a block diagram of the I<sup>2</sup>C interface module in Master mode. Figure 30-3 is a diagram of the I<sup>2</sup>C interface module in Slave mode.

**FIGURE 30-2: MSSP BLOCK DIAGRAM (I<sup>2</sup>C MASTER MODE)**





**FIGURE 30-3: MSSP BLOCK DIAGRAM (I<sup>2</sup>C SLAVE MODE)**



# PIC16(L)F1717/8/9

---

## 30.2 SPI Mode Overview

The Serial Peripheral Interface (SPI) bus is a synchronous serial data communication bus that operates in Full-Duplex mode. Devices communicate in a master/slave environment where the master device initiates the communication. A slave device is controlled through a Chip Select known as Slave Select.

The SPI bus specifies four signal connections:

- Serial Clock (SCK)
- Serial Data Out (SDO)
- Serial Data In (SDI)
- Slave Select ( $\overline{SS}$ )

Figure 30-1 shows the block diagram of the MSSP module when operating in SPI mode.

The SPI bus operates with a single master device and one or more slave devices. When multiple slave devices are used, an independent Slave Select connection is required from the master device to each slave device.

Figure 30-4 shows a typical connection between a master device and multiple slave devices.

The master selects only one slave at a time. Most slave devices have tri-state outputs so their output signal appears disconnected from the bus when they are not selected.

Transmissions involve two shift registers, eight bits in size, one in the master and one in the slave. With either the master or the slave device, data is always shifted out one bit at a time, with the Most Significant bit (MSb) shifted out first. At the same time, a new Least Significant bit (LSb) is shifted into the same register.

Figure 30-5 shows a typical connection between two processors configured as master and slave devices.

Data is shifted out of both shift registers on the programmed clock edge and latched on the opposite edge of the clock.

The master device transmits information out on its SDO output pin which is connected to, and received by, the slave's SDI input pin. The slave device transmits information out on its SDO output pin, which is connected to, and received by, the master's SDI input pin.

To begin communication, the master device first sends out the clock signal. Both the master and the slave devices should be configured for the same clock polarity.

The master device starts a transmission by sending out the MSb from its shift register. The slave device reads this bit from that same line and saves it into the LSb position of its shift register.

During each SPI clock cycle, a full-duplex data transmission occurs. This means that while the master device is sending out the MSb from its shift register (on its SDO pin) and the slave device is reading this bit and saving it as the LSb of its shift register, that the slave device is also sending out the MSb from its shift register (on its SDO pin) and the master device is reading this bit and saving it as the LSb of its shift register.

After eight bits have been shifted out, the master and slave have exchanged register values.

If there is more data to exchange, the shift registers are loaded with new data and the process repeats itself.

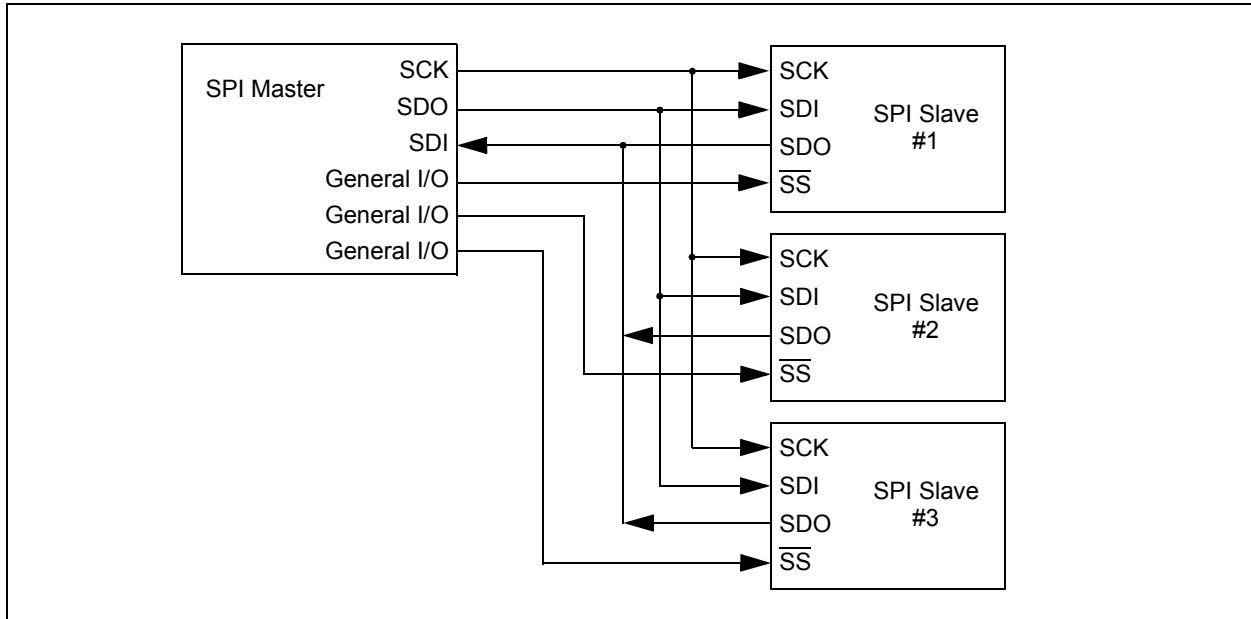
Whether the data is meaningful or not (dummy data), depends on the application software. This leads to three scenarios for data transmission:

- Master sends useful data and slave sends dummy data.
- Master sends useful data and slave sends useful data.
- Master sends dummy data and slave sends useful data.

Transmissions may involve any number of clock cycles. When there is no more data to be transmitted, the master stops sending the clock signal and it deselects the slave.

Every slave device connected to the bus that has not been selected through its slave select line must disregard the clock and transmission signals and must not transmit out any data of its own.

**FIGURE 30-4: SPI MASTER AND MULTIPLE SLAVE CONNECTION**



## 30.2.1 SPI MODE REGISTERS

The MSSP module has five registers for SPI mode operation. These are:

- MSSP STATUS register (SSP1STAT)
- MSSP Control register 1 (SSP1CON1)
- MSSP Control register 3 (SSP1CON3)
- MSSP Data Buffer register (SSP1BUF)
- MSSP Address register (SSP1ADD)
- MSSP Shift register (SSP1SR)  
(Not directly accessible)

SSP1CON1 and SSP1STAT are the control and STATUS registers in SPI mode operation. The SSP1CON1 register is readable and writable. The lower six bits of the SSP1STAT are read-only. The upper two bits of the SSP1STAT are read/write.

In one SPI master mode, SSP1ADD can be loaded with a value used in the Baud Rate Generator. More information on the Baud Rate Generator is available in [Section 30.7 “Baud Rate Generator”](#).

SSP1SR is the shift register used for shifting data in and out. SSP1BUF provides indirect access to the SSP1SR register. SSP1BUF is the buffer register to which data bytes are written, and from which data bytes are read.

In receive operations, SSP1SR and SSP1BUF together create a buffered receiver. When SSP1SR receives a complete byte, it is transferred to SSP1BUF and the SSP1IF interrupt is set.

During transmission, the SSP1BUF is not buffered. A write to SSP1BUF will write to both SSP1BUF and SSP1SR.

## 30.2.2 SPI MODE OPERATION

When initializing the SPI, several options need to be specified. This is done by programming the appropriate control bits (SSP1CON1<5:0> and SSP1STAT<7:6>). These control bits allow the following to be specified:

- Master mode (SCK is the clock output)
- Slave mode (SCK is the clock input)
- Clock Polarity (Idle state of SCK)
- Data Input Sample Phase (middle or end of data output time)
- Clock Edge (output data on rising/falling edge of SCK)
- Clock Rate (Master mode only)
- Slave Select mode (Slave mode only)

To enable the serial port, SSP Enable bit, SSPEN of the SSP1CON1 register, must be set. To reset or reconfigure SPI mode, clear the SSPEN bit, re-initialize the SSP1CONx registers and then set the SSPEN bit. This configures the SDI, SDO, SCK and SS pins as serial port pins. For the pins to behave as the serial port function, some must have their data direction bits (in the TRIS register) appropriately programmed as follows:

- SDI must have corresponding TRIS bit set
- SDO must have corresponding TRIS bit cleared
- SCK (Master mode) must have corresponding TRIS bit cleared
- SCK (Slave mode) must have corresponding TRIS bit set
- SS must have corresponding TRIS bit set

Any serial port function that is not desired may be overridden by programming the corresponding data direction (TRIS) register to the opposite value.

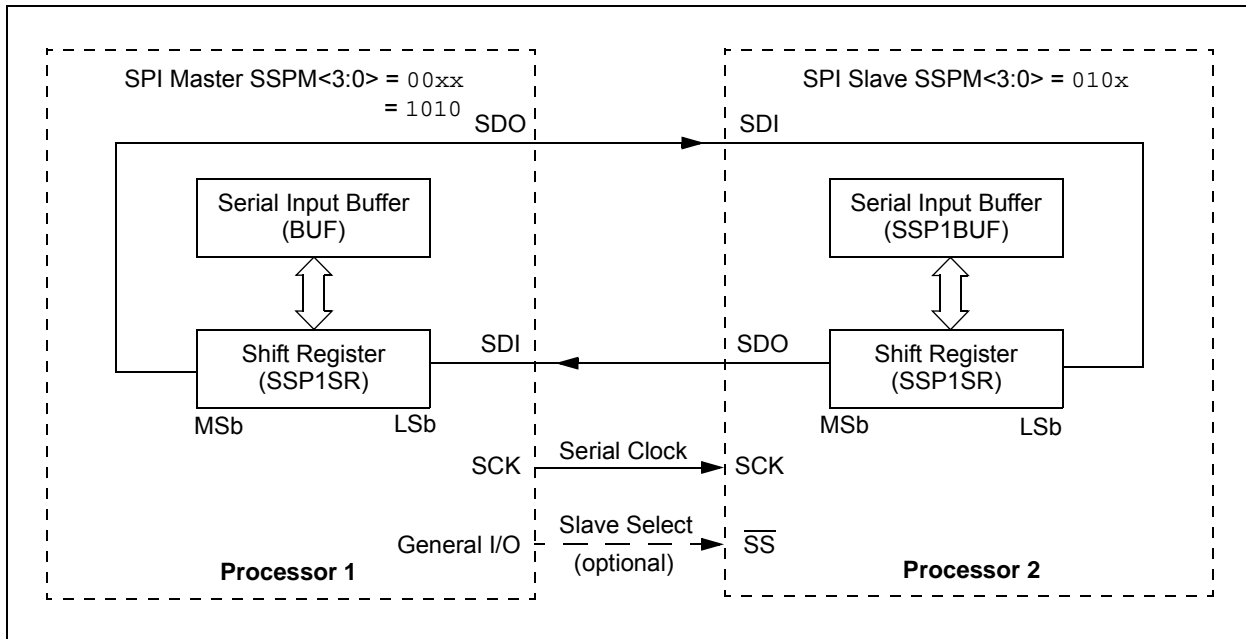
# PIC16(L)F1717/8/9

The MSSP consists of a transmit/receive shift register (SSP1SR) and a buffer register (SSP1BUF). The SSP1SR shifts the data in and out of the device, MSb first. The SSP1BUF holds the data that was written to the SSP1SR until the received data is ready. Once the eight bits of data have been received, that byte is moved to the SSP1BUF register. Then, the Buffer Full detect bit, BF of the SSP1STAT register, and the interrupt flag bit, SSP1IF, are set. This double-buffering of the received data (SSP1BUF) allows the next byte to start reception before reading the data that was just received. Any write to the SSP1BUF register during transmission/reception of data will be ignored and the Write Collision Detect bit WCOL of the SSP1CON1 register, will be set. User software must clear the WCOL bit to allow the following write(s) to the SSP1BUF register to complete successfully.

When the application software is expecting to receive valid data, the SSP1BUF should be read before the next byte of data to transfer is written to the SSP1BUF. The Buffer Full bit, BF of the SSP1STAT register, indicates when SSP1BUF has been loaded with the received data (transmission is complete). When the SSP1BUF is read, the BF bit is cleared. This data may be irrelevant if the SPI is only a transmitter. Generally, the MSSP interrupt is used to determine when the transmission/reception has completed. If the interrupt method is not going to be used, then software polling can be done to ensure that a write collision does not occur.

The SSP1SR is not directly readable or writable and can only be accessed by addressing the SSP1BUF register. Additionally, the SSP1STAT register indicates the various status conditions.

**FIGURE 30-5: SPI MASTER/SLAVE CONNECTION**



## 30.2.3 SPI MASTER MODE

The master can initiate the data transfer at any time because it controls the SCK line. The master determines when the slave (Processor 2, [Figure 30-5](#)) is to broadcast data by the software protocol.

In Master mode, the data is transmitted/received as soon as the SSP1BUF register is written to. If the SPI is only going to receive, the SDO output could be disabled (programmed as an input). The SSP1SR register will continue to shift in the signal present on the SDI pin at the programmed clock rate. As each byte is received, it will be loaded into the SSP1BUF register as if a normal received byte (interrupts and Status bits appropriately set).

The clock polarity is selected by appropriately programming the CKP bit of the SSP1CON1 register and the CKE bit of the SSP1STAT register. This then, would give waveforms for SPI communication as shown in [Figure 30-6](#), [Figure 30-8](#), [Figure 30-9](#) and [Figure 30-10](#), where the MSB is transmitted first. In Master mode, the SPI clock rate (bit rate) is user programmable to be one of the following:

- $F_{OSC}/4$  (or  $T_{CY}$ )
- $F_{OSC}/16$  (or  $4 * T_{CY}$ )
- $F_{OSC}/64$  (or  $16 * T_{CY}$ )
- Timer2 output/2
- $F_{OSC}/(4 * (SSP1ADD + 1))$

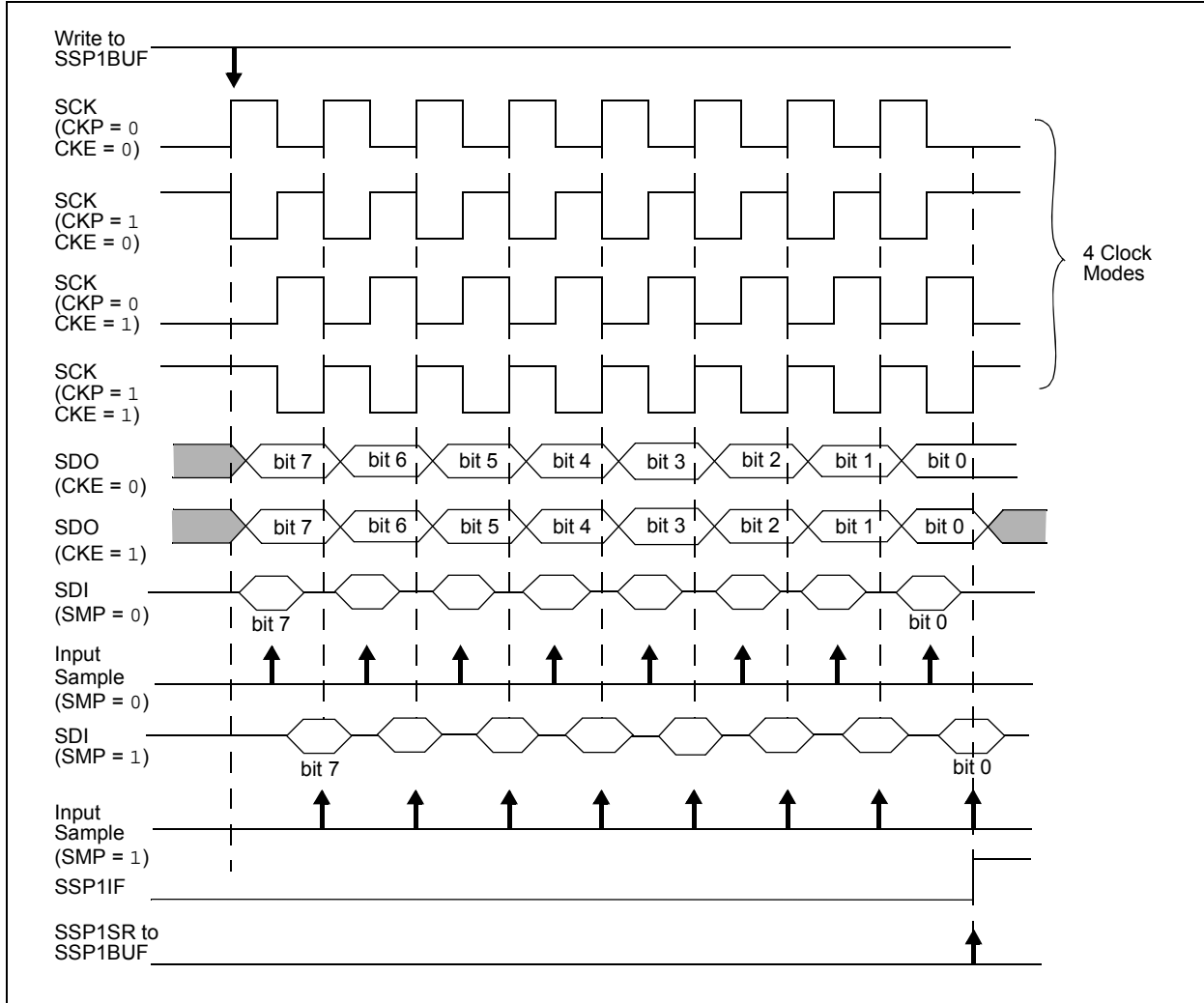
[Figure 30-6](#) shows the waveforms for Master mode.

When the CKE bit is set, the SDO data is valid before there is a clock edge on SCK. The change of the input sample is shown based on the state of the SMP bit. The time when the SSP1BUF is loaded with the received data is shown.

<p><b>Note:</b> In Master mode the clock signal output to the SCK pin is also the clock signal input to the peripheral. The pin selected for output with the RxyPPS register must also be selected as the peripheral input with the SSPCLKPPS register.</p>
---

# PIC16(L)F1717/8/9

**FIGURE 30-6: SPI MODE WAVEFORM (MASTER MODE)**



## 30.2.4 SPI SLAVE MODE

In Slave mode, the data is transmitted and received as external clock pulses appear on SCK. When the last bit is latched, the SSP1IF interrupt flag bit is set.

Before enabling the module in SPI Slave mode, the clock line must match the proper Idle state. The clock line can be observed by reading the SCK pin. The Idle state is determined by the CKP bit of the SSP1CON1 register.

While in Slave mode, the external clock is supplied by the external clock source on the SCK pin. This external clock must meet the minimum high and low times as specified in the electrical specifications.

While in Sleep mode, the slave can transmit/receive data. The shift register is clocked from the SCK pin input and when a byte is received, the device will generate an interrupt. If enabled, the device will wake-up from Sleep.

### 30.2.4.1 Daisy-Chain Configuration

The SPI bus can sometimes be connected in a daisy-chain configuration. The first slave output is connected to the second slave input, the second slave output is connected to the third slave input, and so on. The final slave output is connected to the master input. Each slave sends out, during a second group of clock pulses, an exact copy of what was received during the first group of clock pulses. The whole chain acts as one large communication shift register. The daisy-chain feature only requires a single Slave Select line from the master device.

Figure 30-7 shows the block diagram of a typical daisy-chain connection when operating in SPI mode.

In a daisy-chain configuration, only the most recent byte on the bus is required by the slave. Setting the BOEN bit of the SSP1CON3 register will enable writes to the SSP1BUF register, even if the previous byte has not been read. This allows the software to ignore data that may not apply to it.

## 30.2.5 SLAVE SELECT SYNCHRONIZATION

The Slave Select can also be used to synchronize communication. The Slave Select line is held high until the master device is ready to communicate. When the Slave Select line is pulled low, the slave knows that a new transmission is starting.

If the slave fails to receive the communication properly, it will be reset at the end of the transmission, when the Slave Select line returns to a high state. The slave is then ready to receive a new transmission when the Slave Select line is pulled low again. If the Slave Select line is not used, there is a risk that the slave will eventually become out of sync with the master. If the slave misses a bit, it will always be one bit off in future transmissions. Use of the Slave Select line allows the slave and master to align themselves at the beginning of each transmission.

The  $\overline{SS}$  pin allows a Synchronous Slave mode. The SPI must be in Slave mode with  $\overline{SS}$  pin control enabled ( $SSP1CON1<3:0> = 0100$ ).

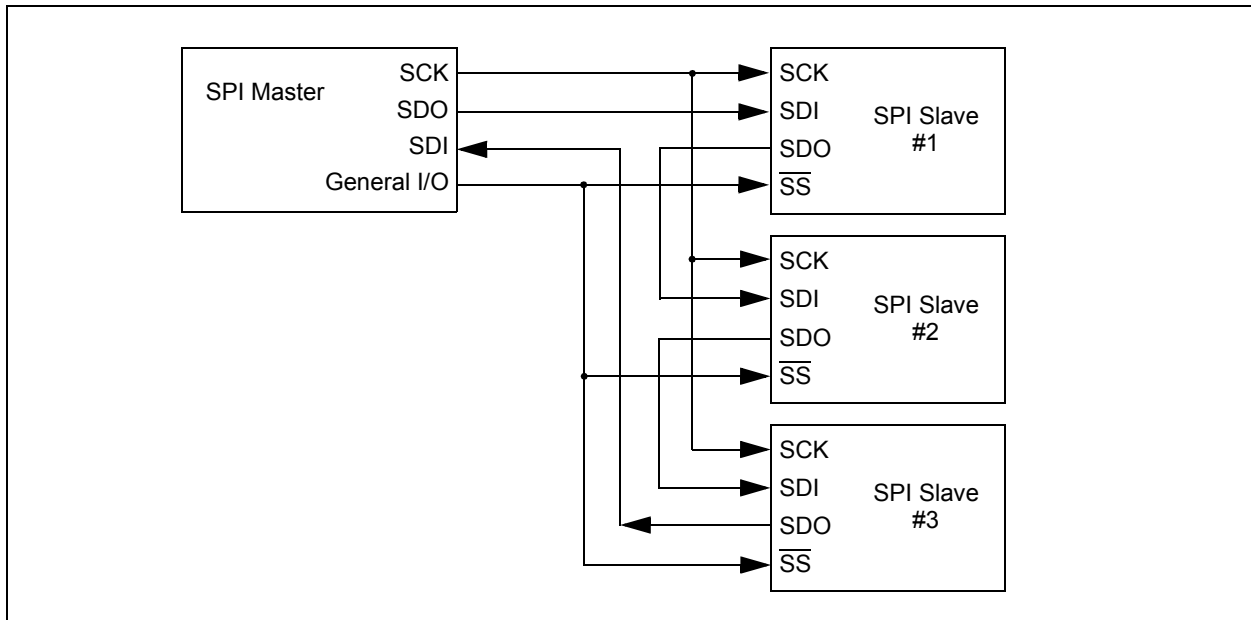
When the  $\overline{SS}$  pin is low, transmission and reception are enabled and the SDO pin is driven.

When the  $\overline{SS}$  pin goes high, the SDO pin is no longer driven, even if in the middle of a transmitted byte and becomes a floating output. External pull-up/pull-down resistors may be desirable depending on the application.

- Note 1:** When the SPI is in Slave mode with  $\overline{SS}$  pin control enabled ( $SSP1CON1<3:0> = 0100$ ), the SPI module will reset if the  $\overline{SS}$  pin is set to VDD.
- 2:** When the SPI is used in Slave mode with CKE set; the user must enable  $\overline{SS}$  pin control.
- 3:** While operated in SPI Slave mode the SMP bit of the SSP1STAT register must remain clear.

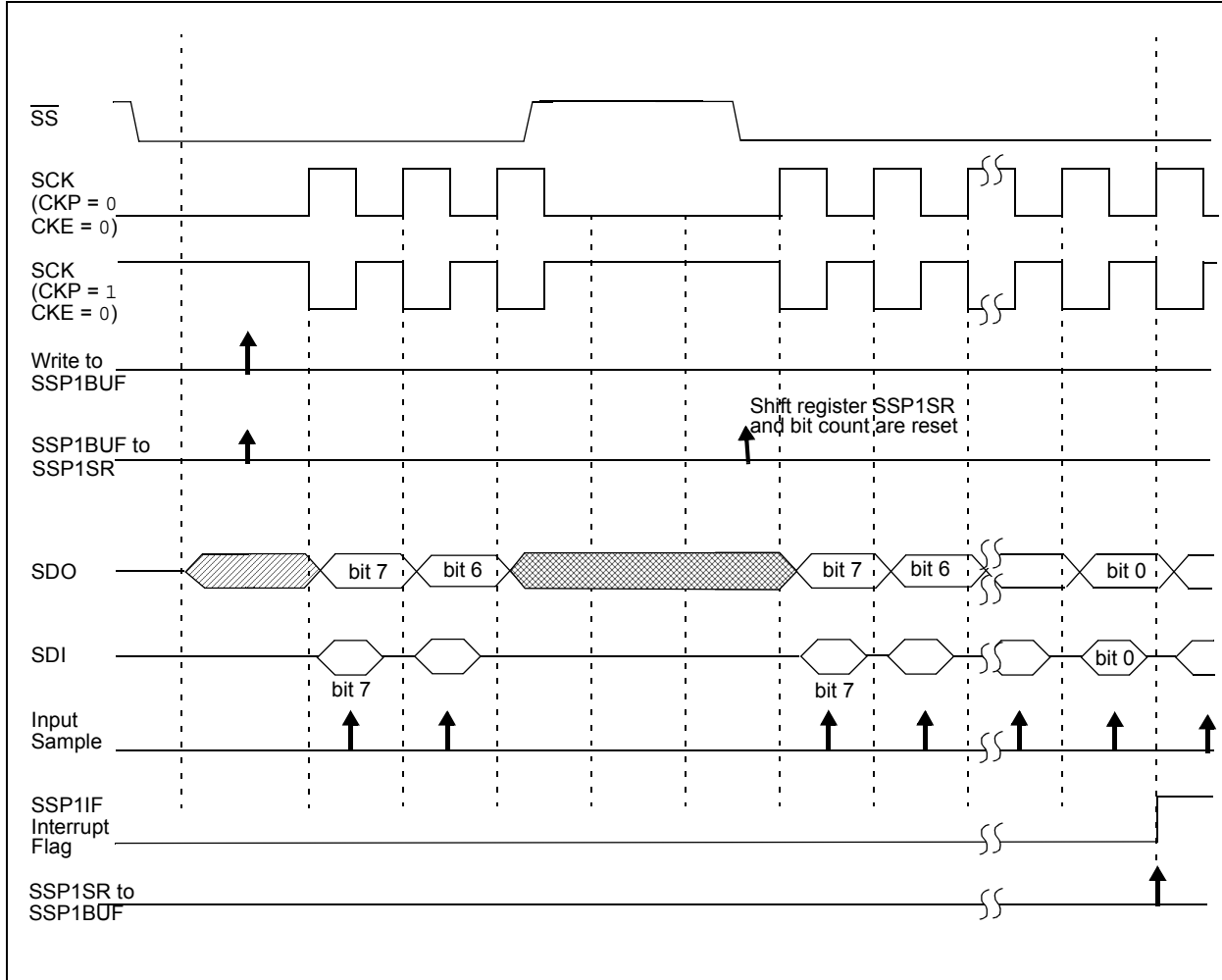
When the SPI module resets, the bit counter is forced to '0'. This can be done by either forcing the  $\overline{SS}$  pin to a high level or clearing the SSPEN bit.

**FIGURE 30-7: SPI DAISY-CHAIN CONNECTION**



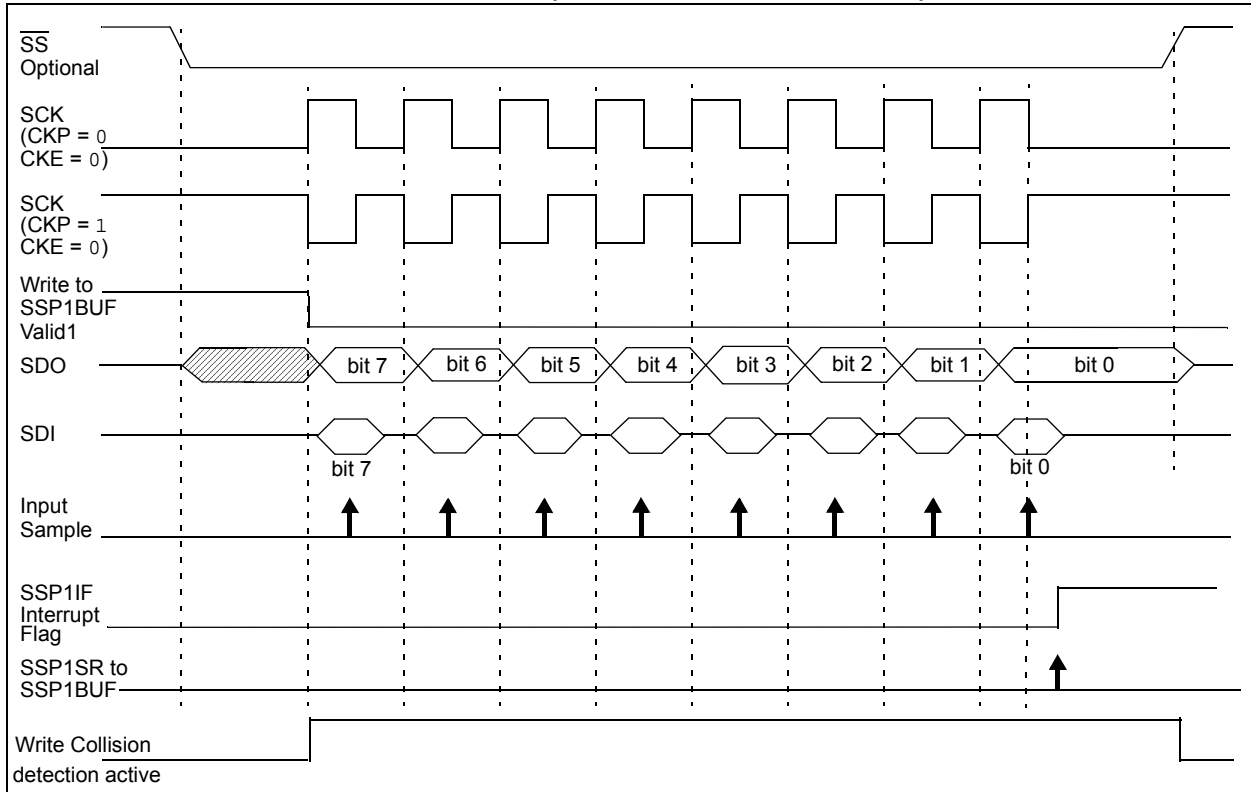
# PIC16(L)F1717/8/9

**FIGURE 30-8: SLAVE SELECT SYNCHRONOUS WAVEFORM**

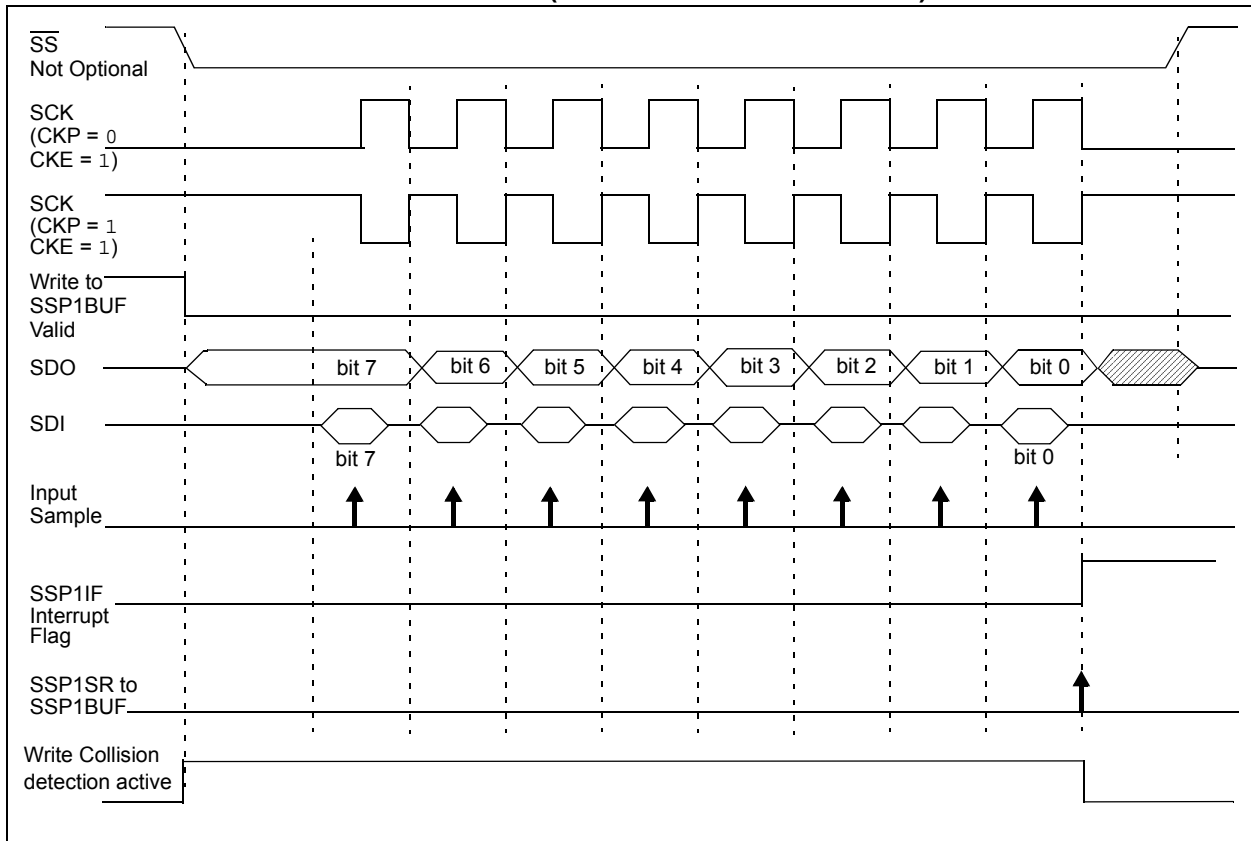




**FIGURE 30-9: SPI MODE WAVEFORM (SLAVE MODE WITH CKE = 0)**



**FIGURE 30-10: SPI MODE WAVEFORM (SLAVE MODE WITH CKE = 1)**



# PIC16(L)F1717/8/9

## 30.2.6 SPI OPERATION IN SLEEP MODE

In SPI Master mode, module clocks may be operating at a different speed than when in Full-Power mode; in the case of the Sleep mode, all clocks are halted.

Special care must be taken by the user when the MSSP clock is much faster than the system clock.

In Slave mode, when MSSP interrupts are enabled, after the master completes sending data, an MSSP interrupt will wake the controller from Sleep.

If an exit from Sleep mode is not desired, MSSP interrupts should be disabled.

In SPI Master mode, when the Sleep mode is selected, all module clocks are halted and the transmission/reception will remain in that state until the device wakes. After the device returns to Run mode, the module will resume transmitting and receiving data.

In SPI Slave mode, the SPI Transmit/Receive Shift register operates asynchronously to the device. This allows the device to be placed in Sleep mode and data to be shifted into the SPI Transmit/Receive Shift register. When all eight bits have been received, the MSSP interrupt flag bit will be set and if enabled, will wake the device.

**TABLE 30-1: SUMMARY OF REGISTERS ASSOCIATED WITH SPI OPERATION**

Name	Bit 7	Bit 6	Bit 5	Bit 4	Bit 3	Bit 2	Bit 1	Bit 0	Register on Page
ANSELA	—	—	ANSA5	ANSA4	ANSA3	ANSA2	ANSA1	ANSA0	125
ANSELB	—	—	ANSB5	ANSB4	ANSB3	ANSB2	ANSB1	ANSB0	131
ANSELC	ANSC7	ANSC6	ANSC5	ANSC4	ANSC3	ANSC2	—	—	136
ANSELD <sup>(1)</sup>	ANS7	ANS6	ANS5	ANS4	ANS3	ANS2	ANS1	ANS0	141
INTCON	GIE	PEIE	TMR0IE	INTE	IOCIE	TMR0IF	INTF	IOCIF	90
PIE1	TMR1GIE	ADIE	RCIE	TXIE	SSP1IE	CCP1IE	TMR2IE	TMR1IE	91
PIR1	TMR1GIF	ADIF	RCIF	TXIF	SSP1IF	CCP1IF	TMR2IF	TMR1IF	94
RxyPPS	—	—	—	RxyPPS<4:0>					153
SSPCLKPPS	—	—	—	SSPCLKPPS<4:0>					152
SSPDATPPS	—	—	—	SSPDATPPS<4:0>					152
SSPSSPPS	—	—	—	SSPSSPPS<4:0>					152
SSP1BUF	Synchronous Serial Port Receive Buffer/Transmit Register								299*
SSP1CON1	WCOL	SSPOV	SSPEN	CKP	SSPM<3:0>				346
SSP1CON3	ACKTIM	PCIE	SCIE	BOEN	SDAHT	SBCDE	AHEN	DHEN	349
SSP1STAT	SMP	CKE	D/Ā	P	S	R/W	UA	BF	345
TRISA	TRISA7	TRISA6	TRISA5	TRISA4	TRISA3	TRISA2	TRISA1	TRISA0	124
TRISB	TRISB7	TRISB6	TRISB5	TRISB4	TRISB3	TRISB2	TRISB1	TRISB0	130
TRISC	TRISC7	TRISC6	TRISC5	TRISC4	TRISC3	TRISC2	TRISC1	TRISC0	135
TRISD <sup>(1)</sup>	TRISD7	TRISD6	TRISD5	TRISD4	TRISD3	TRISD2	TRISD1	TRISD0	140

**Legend:** — = Unimplemented location, read as '0'. Shaded cells are not used by the MSSP in SPI mode.

\* Page provides register information.

**Note 1:** PIC16(L)F1717/9 only.

## 30.3 I<sup>2</sup>C MODE OVERVIEW

The Inter-Integrated Circuit (I<sup>2</sup>C) bus is a multi-master serial data communication bus. Devices communicate in a master/slave environment where the master devices initiate the communication. A slave device is controlled through addressing.

The I<sup>2</sup>C bus specifies two signal connections:

- Serial Clock (SCL)
- Serial Data (SDA)

Figure 30-11 shows the block diagram of the MSSP module when operating in I<sup>2</sup>C mode.

Both the SCL and SDA connections are bidirectional open-drain lines, each requiring pull-up resistors for the supply voltage. Pulling the line to ground is considered a logical zero and letting the line float is considered a logical one.

Figure 30-11 shows a typical connection between two processors configured as master and slave devices.

The I<sup>2</sup>C bus can operate with one or more master devices and one or more slave devices.

There are four potential modes of operation for a given device:

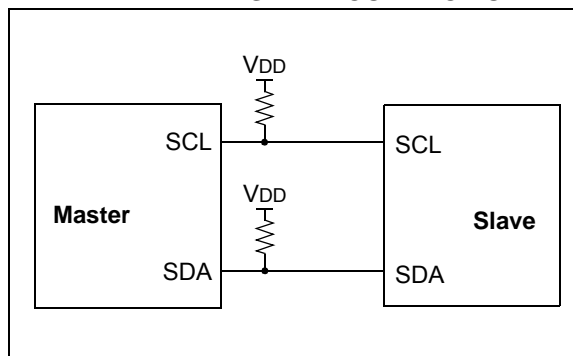
- Master Transmit mode  
(master is transmitting data to a slave)
- Master Receive mode  
(master is receiving data from a slave)
- Slave Transmit mode  
(slave is transmitting data to a master)
- Slave Receive mode  
(slave is receiving data from the master)

To begin communication, a master device starts out in Master Transmit mode. The master device sends out a Start bit followed by the address byte of the slave it intends to communicate with. This is followed by a single Read/Write bit, which determines whether the master intends to transmit to or receive data from the slave device.

If the requested slave exists on the bus, it will respond with an Acknowledge bit, otherwise known as an  $\overline{\text{ACK}}$ . The master then continues in either Transmit mode or Receive mode and the slave continues in the complement, either in Receive mode or Transmit mode, respectively.

A Start bit is indicated by a high-to-low transition of the SDA line while the SCL line is held high. Address and data bytes are sent out, Most Significant bit (MSb) first. The Read/Write bit is sent out as a logical one when the master intends to read data from the slave, and is sent out as a logical zero when it intends to write data to the slave.

FIGURE 30-11: I<sup>2</sup>C MASTER/SLAVE CONNECTION



The Acknowledge bit ( $\overline{\text{ACK}}$ ) is an active-low signal, which holds the SDA line low to indicate to the transmitter that the slave device has received the transmitted data and is ready to receive more.

The transition of a data bit is always performed while the SCL line is held low. Transitions that occur while the SCL line is held high are used to indicate Start and Stop bits.

If the master intends to write to the slave, then it repeatedly sends out a byte of data, with the slave responding after each byte with an  $\overline{\text{ACK}}$  bit. In this example, the master device is in Master Transmit mode and the slave is in Slave Receive mode.

If the master intends to read from the slave, then it repeatedly receives a byte of data from the slave, and responds after each byte with an  $\overline{\text{ACK}}$  bit. In this example, the master device is in Master Receive mode and the slave is Slave Transmit mode.

On the last byte of data communicated, the master device may end the transmission by sending a Stop bit. If the master device is in Receive mode, it sends the Stop bit in place of the last  $\overline{\text{ACK}}$  bit. A Stop bit is indicated by a low-to-high transition of the SDA line while the SCL line is held high.

In some cases, the master may want to maintain control of the bus and re-initiate another transmission. If so, the master device may send another Start bit in place of the Stop bit or last  $\overline{\text{ACK}}$  bit when it is in receive mode.

The I<sup>2</sup>C bus specifies three message protocols;

- Single message where a master writes data to a slave.
- Single message where a master reads data from a slave.
- Combined message where a master initiates a minimum of two writes, or two reads, or a combination of writes and reads, to one or more slaves.

# PIC16(L)F1717/8/9

---

When one device is transmitting a logical one, or letting the line float, and a second device is transmitting a logical zero, or holding the line low, the first device can detect that the line is not a logical one. This detection, when used on the SCL line, is called clock stretching. Clock stretching gives slave devices a mechanism to control the flow of data. When this detection is used on the SDA line, it is called arbitration. Arbitration ensures that there is only one master device communicating at any single time.

## 30.3.1 CLOCK STRETCHING

When a slave device has not completed processing data, it can delay the transfer of more data through the process of clock stretching. An addressed slave device may hold the SCL clock line low after receiving or sending a bit, indicating that it is not yet ready to continue. The master that is communicating with the slave will attempt to raise the SCL line in order to transfer the next bit, but will detect that the clock line has not yet been released. Because the SCL connection is open-drain, the slave has the ability to hold that line low until it is ready to continue communicating.

Clock stretching allows receivers that cannot keep up with a transmitter to control the flow of incoming data.

## 30.3.2 ARBITRATION

Each master device must monitor the bus for Start and Stop bits. If the device detects that the bus is busy, it cannot begin a new message until the bus returns to an Idle state.

However, two master devices may try to initiate a transmission on or about the same time. When this occurs, the process of arbitration begins. Each transmitter checks the level of the SDA data line and compares it to the level that it expects to find. The first transmitter to observe that the two levels do not match, loses arbitration, and must stop transmitting on the SDA line.

For example, if one transmitter holds the SDA line to a logical one (lets it float) and a second transmitter holds it to a logical zero (pulls it low), the result is that the SDA line will be low. The first transmitter then observes that the level of the line is different than expected and concludes that another transmitter is communicating.

The first transmitter to notice this difference is the one that loses arbitration and must stop driving the SDA line. If this transmitter is also a master device, it also must stop driving the SCL line. It then can monitor the lines for a Stop condition before trying to reissue its transmission. In the meantime, the other device that has not noticed any difference between the expected and actual levels on the SDA line continues with its original transmission. It can do so without any complications, because so far, the transmission appears exactly as expected with no other transmitter disturbing the message.

Slave Transmit mode can also be arbitrated, when a master addresses multiple slaves, but this is less common.

If two master devices are sending a message to two different slave devices at the address stage, the master sending the lower slave address always wins arbitration. When two master devices send messages to the same slave address, and addresses can sometimes refer to multiple slaves, the arbitration process must continue into the data stage.

Arbitration usually occurs very rarely, but it is a necessary process for proper multi-master support.

## 30.4 I<sup>2</sup>C MODE OPERATION

All MSSP I<sup>2</sup>C communication is byte oriented and shifted out MSb first. Six SFR registers and two interrupt flags interface the module with the PIC<sup>®</sup> microcontroller and user software. Two pins, SDA and SCL, are exercised by the module to communicate with other external I<sup>2</sup>C devices.

### 30.4.1 BYTE FORMAT

All communication in I<sup>2</sup>C is done in 9-bit segments. A byte is sent from a master to a slave or vice-versa, followed by an Acknowledge bit sent back. After the eighth falling edge of the SCL line, the device outputting data on the SDA changes that pin to an input and reads in an acknowledge value on the next clock pulse.

The clock signal, SCL, is provided by the master. Data is valid to change while the SCL signal is low, and sampled on the rising edge of the clock. Changes on the SDA line while the SCL line is high define special conditions on the bus, explained below.

### 30.4.2 DEFINITION OF I<sup>2</sup>C TERMINOLOGY

There is language and terminology in the description of I<sup>2</sup>C communication that have definitions specific to I<sup>2</sup>C. That word usage is defined below and may be used in the rest of this document without explanation. [Table 30-2](#) was adapted from the Philips I<sup>2</sup>C specification.

### 30.4.3 SDA AND SCL PINS

Selection of any I<sup>2</sup>C mode with the SSPEN bit set, forces the SCL and SDA pins to be open-drain. These pins should be set by the user to inputs by setting the appropriate TRIS bits.

**Note 1:** Data is tied to output zero when an I<sup>2</sup>C mode is enabled.

**2:** Any device pin can be selected for SDA and SCL functions with the PPS peripheral. These functions are bidirectional. The SDA input is selected with the SSPDATPPS registers. The SCL input is selected with the SSPCLKPPS registers. Outputs are selected with the RxyPPS registers. It is the user's responsibility to make the selections so that both the input and the output for each function is on the same pin.

### 30.4.4 SDA HOLD TIME

The hold time of the SDA pin is selected by the SDAHT bit of the SSP1CON3 register. Hold time is the time SDA is held valid after the falling edge of SCL. Setting the SDAHT bit selects a longer 300 ns minimum hold time and may help on buses with large capacitance.

**TABLE 30-2: I<sup>2</sup>C BUS TERMS**

TERM	Description
Transmitter	The device which shifts data out onto the bus.
Receiver	The device which shifts data in from the bus.
Master	The device that initiates a transfer, generates clock signals and terminates a transfer.
Slave	The device addressed by the master.
Multi-master	A bus with more than one device that can initiate data transfers.
Arbitration	Procedure to ensure that only one master at a time controls the bus. Winning arbitration ensures that the message is not corrupted.
Synchronization	Procedure to synchronize the clocks of two or more devices on the bus.
Idle	No master is controlling the bus, and both SDA and SCL lines are high.
Active	Any time one or more master devices are controlling the bus.
Addressed Slave	Slave device that has received a matching address and is actively being clocked by a master.
Matching Address	Address byte that is clocked into a slave that matches the value stored in SSP1ADD.
Write Request	Slave receives a matching address with R/W bit clear, and is ready to clock in data.
Read Request	Master sends an address byte with the R/W bit set, indicating that it wishes to clock data out of the Slave. This data is the next and all following bytes until a Restart or Stop.
Clock Stretching	When a device on the bus hold SCL low to stall communication.
Bus Collision	Any time the SDA line is sampled low by the module while it is outputting and expected high state.

# PIC16(L)F1717/8/9

## 30.4.5 START CONDITION

The I<sup>2</sup>C specification defines a Start condition as a transition of SDA from a high to a low state while SCL line is high. A Start condition is always generated by the master and signifies the transition of the bus from an Idle to an Active state. Figure 30-12 shows wave forms for Start and Stop conditions.

A bus collision can occur on a Start condition if the module samples the SDA line low before asserting it low. This does not conform to the I<sup>2</sup>C Specification that states no bus collision can occur on a Start.

## 30.4.6 STOP CONDITION

A Stop condition is a transition of the SDA line from low-to-high state while the SCL line is high.

**Note:** At least one SCL low time must appear before a Stop is valid, therefore, if the SDA line goes low then high again while the SCL line stays high, only the Start condition is detected.

## 30.4.7 RESTART CONDITION

A Restart is valid any time that a Stop would be valid. A master can issue a Restart if it wishes to hold the bus after terminating the current transfer. A Restart has the same effect on the slave that a Start would, resetting all slave logic and preparing it to clock in an address. The master may want to address the same or another slave. Figure 30-13 shows the wave form for a Restart condition.

In 10-bit Addressing Slave mode a Restart is required for the master to clock data out of the addressed slave. Once a slave has been fully addressed, matching both high and low address bytes, the master can issue a Restart and the high address byte with the R/W bit set. The slave logic will then hold the clock and prepare to clock out data.

After a full match with R/W clear in 10-bit mode, a prior match flag is set and maintained until a Stop condition, a high address with R/W clear, or high address match fails.

## 30.4.8 START/STOP CONDITION INTERRUPT MASKING

The SCIE and PCIE bits of the SSP1CON3 register can enable the generation of an interrupt in Slave modes that do not typically support this function. Slave modes where interrupt on Start and Stop detect are already enabled, these bits will have no effect.

FIGURE 30-12: I<sup>2</sup>C START AND STOP CONDITIONS

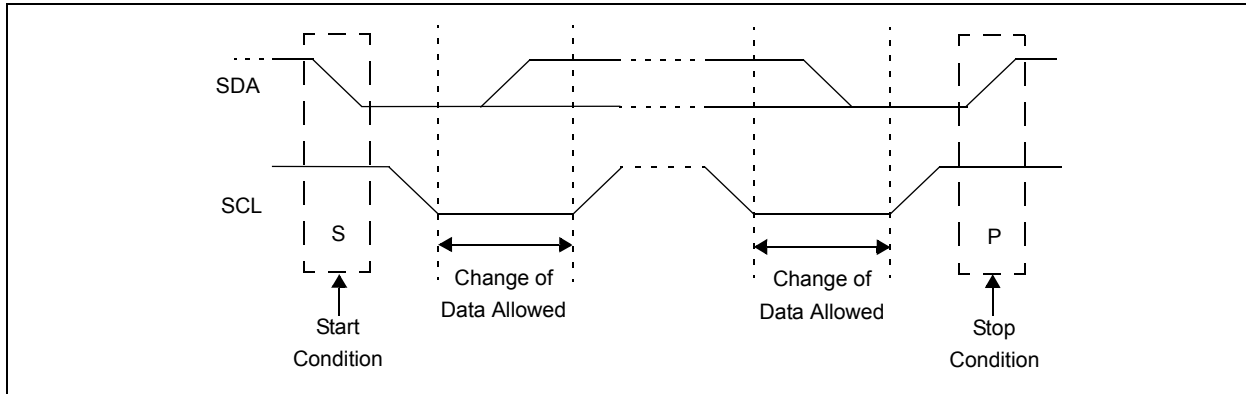
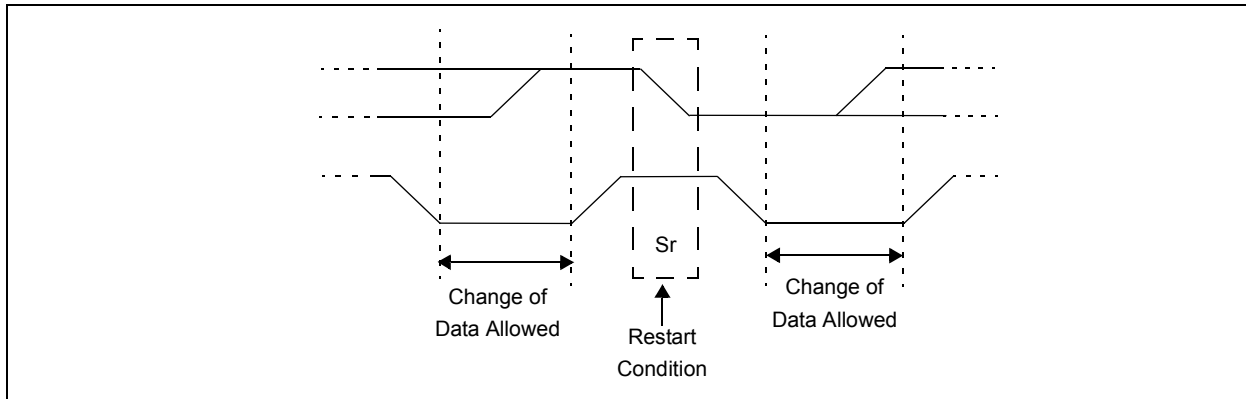


FIGURE 30-13: I<sup>2</sup>C RESTART CONDITION



## 30.4.9 ACKNOWLEDGE SEQUENCE

The 9th SCL pulse for any transferred byte in I<sup>2</sup>C is dedicated as an Acknowledge. It allows receiving devices to respond back to the transmitter by pulling the SDA line low. The transmitter must release control of the line during this time to shift in the response. The Acknowledge ( $\overline{\text{ACK}}$ ) is an active-low signal, pulling the SDA line low indicates to the transmitter that the device has received the transmitted data and is ready to receive more.

The result of an  $\overline{\text{ACK}}$  is placed in the ACKSTAT bit of the SSP1CON2 register.

Slave software, when the AHEN and DHEN bits are set, allow the user to set the  $\overline{\text{ACK}}$  value sent back to the transmitter. The ACKDT bit of the SSP1CON2 register is set/cleared to determine the response.

Slave hardware will generate an  $\overline{\text{ACK}}$  response if the AHEN and DHEN bits of the SSP1CON3 register are clear.

There are certain conditions where an  $\overline{\text{ACK}}$  will not be sent by the slave. If the BF bit of the SSP1STAT register or the SSPOV bit of the SSP1CON1 register are set when a byte is received.

When the module is addressed, after the eighth falling edge of SCL on the bus, the ACKTIM bit of the SSP1CON3 register is set. The ACKTIM bit indicates the acknowledge time of the active bus. The ACKTIM Status bit is only active when the AHEN bit or DHEN bit is enabled.

## 30.5 I<sup>2</sup>C SLAVE MODE OPERATION

The MSSP Slave mode operates in one of four modes selected by the SSPM bits of SSP1CON1 register. The modes can be divided into 7-bit and 10-bit Addressing mode. 10-bit Addressing modes operate the same as 7-bit with some additional overhead for handling the larger addresses.

Modes with Start and Stop bit interrupts operate the same as the other modes with SSP1IF additionally getting set upon detection of a Start, Restart, or Stop condition.

### 30.5.1 SLAVE MODE ADDRESSES

The SSP1ADD register ([Register 30-6](#)) contains the Slave mode address. The first byte received after a Start or Restart condition is compared against the value stored in this register. If the byte matches, the value is loaded into the SSP1BUF register and an interrupt is generated. If the value does not match, the module goes idle and no indication is given to the software that anything happened.

The SSP Mask register ([Register 30-5](#)) affects the address matching process. See [Section 30.5.9 "SSP Mask Register"](#) for more information.

#### 30.5.1.1 I<sup>2</sup>C Slave 7-Bit Addressing Mode

In 7-bit Addressing mode, the LSB of the received data byte is ignored when determining if there is an address match.

#### 30.5.1.2 I<sup>2</sup>C Slave 10-Bit Addressing Mode

In 10-bit Addressing mode, the first received byte is compared to the binary value of '1 1 1 0 A9 A8 0'. A9 and A8 are the two MSb's of the 10-bit address and stored in bits 2 and 1 of the SSP1ADD register.

After the acknowledge of the high byte the UA bit is set and SCL is held low until the user updates SSP1ADD with the low address. The low address byte is clocked in and all eight bits are compared to the low address value in SSP1ADD. Even if there is not an address match; SSP1IF and UA are set, and SCL is held low until SSP1ADD is updated to receive a high byte again. When SSP1ADD is updated the UA bit is cleared. This ensures the module is ready to receive the high address byte on the next communication.

A high and low address match as a write request is required at the start of all 10-bit addressing communication. A transmission can be initiated by issuing a Restart once the slave is addressed, and clocking in the high address with the R/W bit set. The slave hardware will then acknowledge the read request and prepare to clock out data. This is only valid for a slave after it has received a complete high and low address byte match.

# PIC16(L)F1717/8/9

## 30.5.2 SLAVE RECEPTION

When the  $R/\overline{W}$  bit of a matching received address byte is clear, the  $R/\overline{W}$  bit of the SSP1STAT register is cleared. The received address is loaded into the SSP1BUF register and acknowledged.

When the overflow condition exists for a received address, then not Acknowledge is given. An overflow condition is defined as either bit BF of the SSP1STAT register is set, or bit SSPOV of the SSP1CON1 register is set. The BOEN bit of the SSP1CON3 register modifies this operation. For more information see [Register 30-4](#).

An MSSP interrupt is generated for each transferred data byte. Flag bit, SSP1IF, must be cleared by software.

When the SEN bit of the SSP1CON2 register is set, SCL will be held low (clock stretch) following each received byte. The clock must be released by setting the CKP bit of the SSP1CON1 register, except sometimes in 10-bit mode. See [Section 30.5.6.2 “10-Bit Addressing Mode”](#) for more detail.

### 30.5.2.1 7-Bit Addressing Reception

This section describes a standard sequence of events for the MSSP module configured as an I<sup>2</sup>C slave in 7-bit Addressing mode. [Figure 30-14](#) and [Figure 30-15](#) is used as a visual reference for this description.

This is a step by step process of what typically must be done to accomplish I<sup>2</sup>C communication.

1. Start bit detected.
2. S bit of SSP1STAT is set; SSP1IF is set if interrupt on Start detect is enabled.
3. Matching address with  $R/\overline{W}$  bit clear is received.
4. The slave pulls SDA low sending an  $\overline{ACK}$  to the master, and sets SSP1IF bit.
5. Software clears the SSP1IF bit.
6. Software reads received address from SSP1BUF clearing the BF flag.
7. If SEN = 1; Slave software sets CKP bit to release the SCL line.
8. The master clocks out a data byte.
9. Slave drives SDA low sending an  $\overline{ACK}$  to the master, and sets SSP1IF bit.
10. Software clears SSP1IF.
11. Software reads the received byte from SSP1BUF clearing BF.
12. Steps 8-12 are repeated for all received bytes from the master.
13. Master sends Stop condition, setting P bit of SSP1STAT, and the bus goes idle.

### 30.5.2.2 7-Bit Reception with AHEN and DHEN

Slave device reception with AHEN and DHEN set operate the same as without these options with extra interrupts and clock stretching added after the eighth falling edge of SCL. These additional interrupts allow the slave software to decide whether it wants to  $\overline{ACK}$  the receive address or data byte, rather than the hardware. This functionality adds support for PMBus™ that was not present on previous versions of this module.

This list describes the steps that need to be taken by slave software to use these options for I<sup>2</sup>C communication. [Figure 30-16](#) displays a module using both address and data holding. [Figure 30-17](#) includes the operation with the SEN bit of the SSP1CON2 register set.

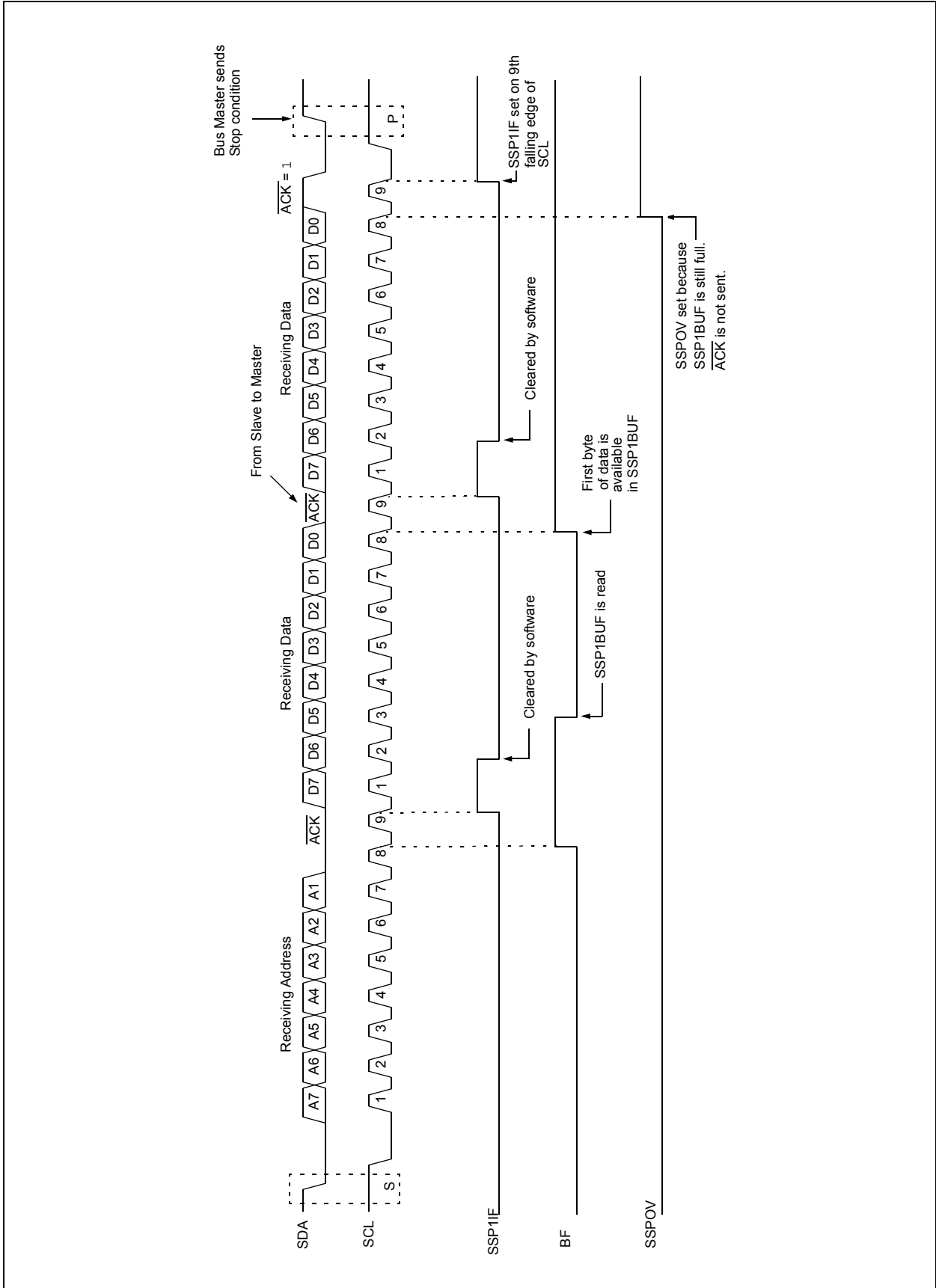
1. S bit of SSP1STAT is set; SSP1IF is set if interrupt on Start detect is enabled.
2. Matching address with  $R/\overline{W}$  bit clear is clocked in. SSP1IF is set and CKP cleared after the eighth falling edge of SCL.
3. Slave clears the SSP1IF.
4. Slave can look at the ACKTIM bit of the SSP1CON3 register to determine if the SSP1IF was after or before the  $\overline{ACK}$ .
5. Slave reads the address value from SSP1BUF, clearing the BF flag.
6. Slave sets  $\overline{ACK}$  value clocked out to the master by setting ACKDT.
7. Slave releases the clock by setting CKP.
8. SSP1IF is set after an  $\overline{ACK}$ , not after a NACK.
9. If SEN = 1 the slave hardware will stretch the clock after the  $\overline{ACK}$ .
10. Slave clears SSP1IF.

**Note:** SSP1IF is still set after the 9th falling edge of SCL even if there is no clock stretching and BF has been cleared. Only if NACK is sent to master is SSP1IF not set

11. SSP1IF set and CKP cleared after eighth falling edge of SCL for a received data byte.
12. Slave looks at ACKTIM bit of SSP1CON3 to determine the source of the interrupt.
13. Slave reads the received data from SSP1BUF clearing BF.
14. Steps 7-14 are the same for each received data byte.
15. Communication is ended by either the slave sending an  $\overline{ACK} = 1$ , or the master sending a Stop condition. If a Stop is sent and Interrupt on Stop Detect is disabled, the slave will only know by polling the P bit of the SSTAT register.

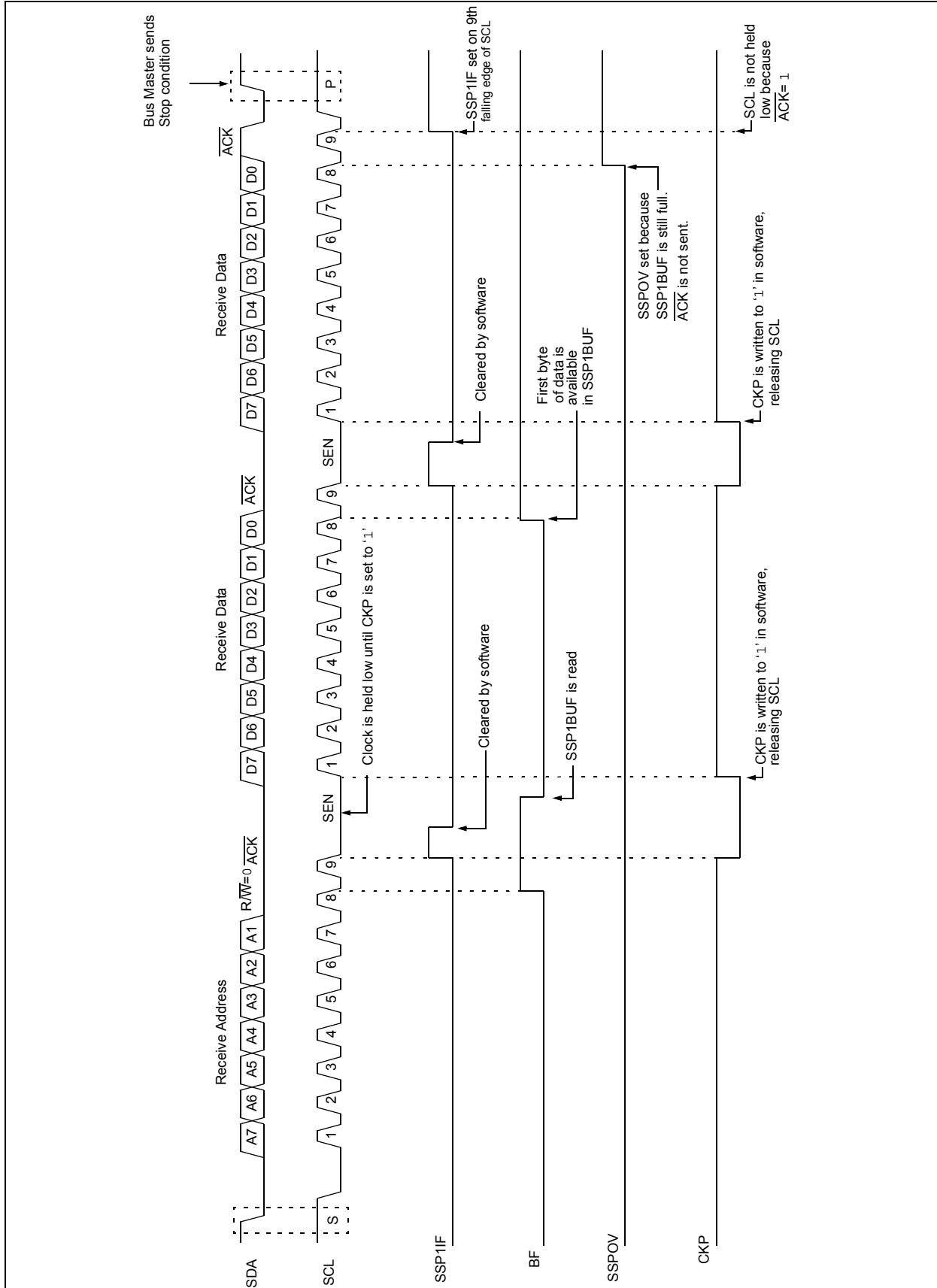


**FIGURE 30-14: I<sup>2</sup>C SLAVE, 7-BIT ADDRESS, RECEPTION (SEN = 0, AHEN = 0, DHEN = 0)**

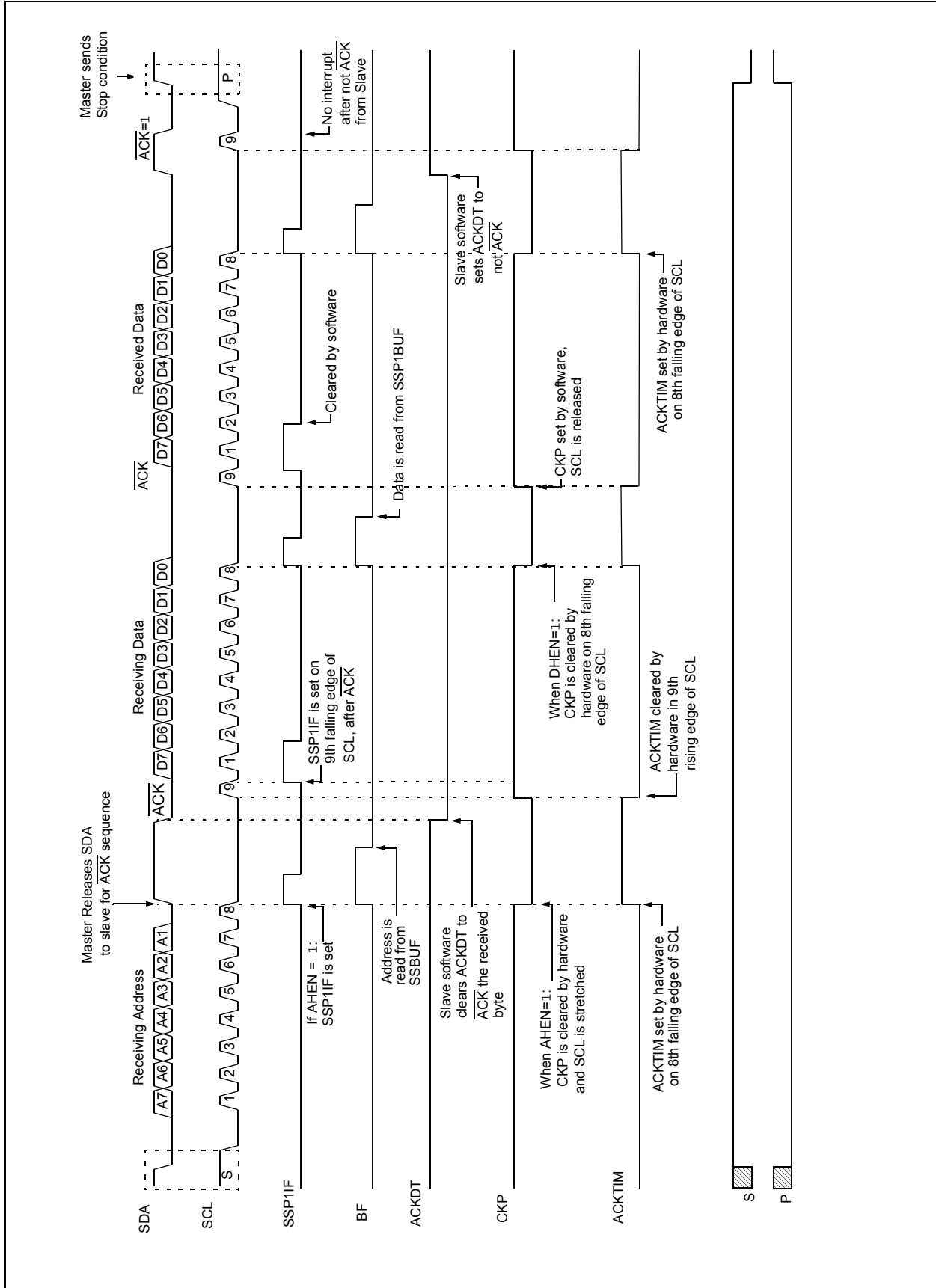


# PIC16(L)F1717/8/9

FIGURE 30-15: I<sup>2</sup>C SLAVE, 7-BIT ADDRESS, RECEPTION (SEN = 1, AHEN = 0, DHEN = 0)

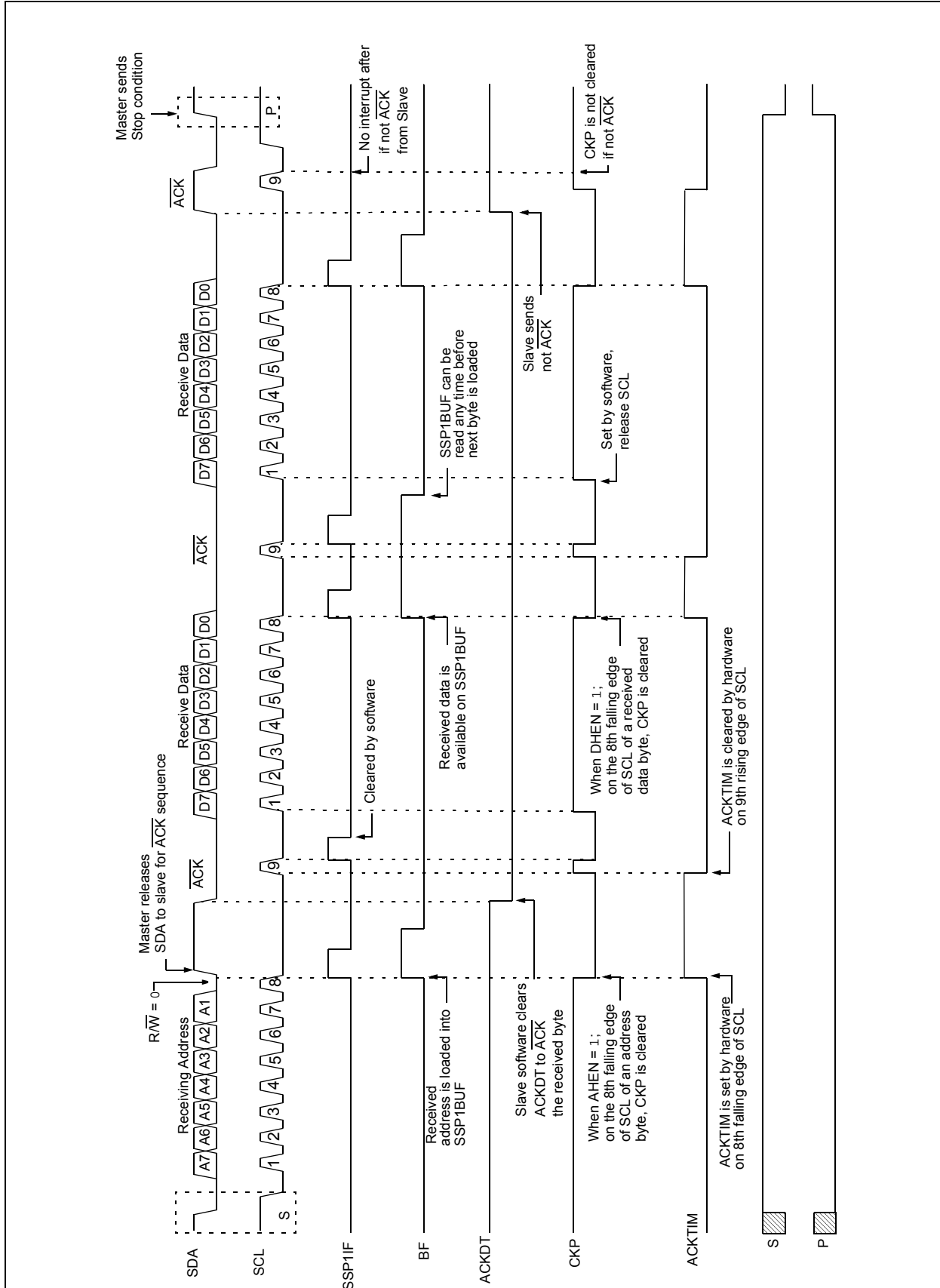


**FIGURE 30-16: I<sup>2</sup>C SLAVE, 7-BIT ADDRESS, RECEPTION (SEN = 0, AHEN = 1, DHEN = 1)**



# PIC16(L)F1717/8/9

FIGURE 30-17: I<sup>2</sup>C SLAVE, 7-BIT ADDRESS, RECEPTION (SEN = 1, AHEN = 1, DHEN = 1)



## 30.5.3 SLAVE TRANSMISSION

When the  $\overline{R/W}$  bit of the incoming address byte is set and an address match occurs, the  $\overline{R/W}$  bit of the SSP1STAT register is set. The received address is loaded into the SSP1BUF register, and an ACK pulse is sent by the slave on the ninth bit.

Following the  $\overline{ACK}$ , slave hardware clears the CKP bit and the SCL pin is held low (see [Section 30.5.6 “Clock Stretching”](#) for more detail). By stretching the clock, the master will be unable to assert another clock pulse until the slave is done preparing the transmit data.

The transmit data must be loaded into the SSP1BUF register which also loads the SSP1SR register. Then the SCL pin should be released by setting the CKP bit of the SSP1CON1 register. The eight data bits are shifted out on the falling edge of the SCL input. This ensures that the SDA signal is valid during the SCL high time.

The  $\overline{ACK}$  pulse from the master-receiver is latched on the rising edge of the ninth SCL input pulse. This ACK value is copied to the ACKSTAT bit of the SSP1CON2 register. If ACKSTAT is set (not ACK), then the data transfer is complete. In this case, when the not  $\overline{ACK}$  is latched by the slave, the slave goes idle and waits for another occurrence of the Start bit. If the SDA line was low (ACK), the next transmit data must be loaded into the SSP1BUF register. Again, the SCL pin must be released by setting bit CKP.

An MSSP interrupt is generated for each data transfer byte. The SSP1IF bit must be cleared by software and the SSP1STAT register is used to determine the status of the byte. The SSP1IF bit is set on the falling edge of the ninth clock pulse.

### 30.5.3.1 Slave Mode Bus Collision

A slave receives a Read request and begins shifting data out on the SDA line. If a bus collision is detected and the SBCDE bit of the SSP1CON3 register is set, the BCL1IF bit of the PIR2 register is set. Once a bus collision is detected, the slave goes idle and waits to be addressed again. User software can use the BCL1IF bit to handle a slave bus collision.

# PIC16(L)F1717/8/9

---

## 30.5.3.2 7-Bit Transmission

A master device can transmit a read request to a slave, and then clock data out of the slave. The list below outlines what software for a slave will need to do to accomplish a standard transmission. [Figure 30-18](#) can be used as a reference to this list.

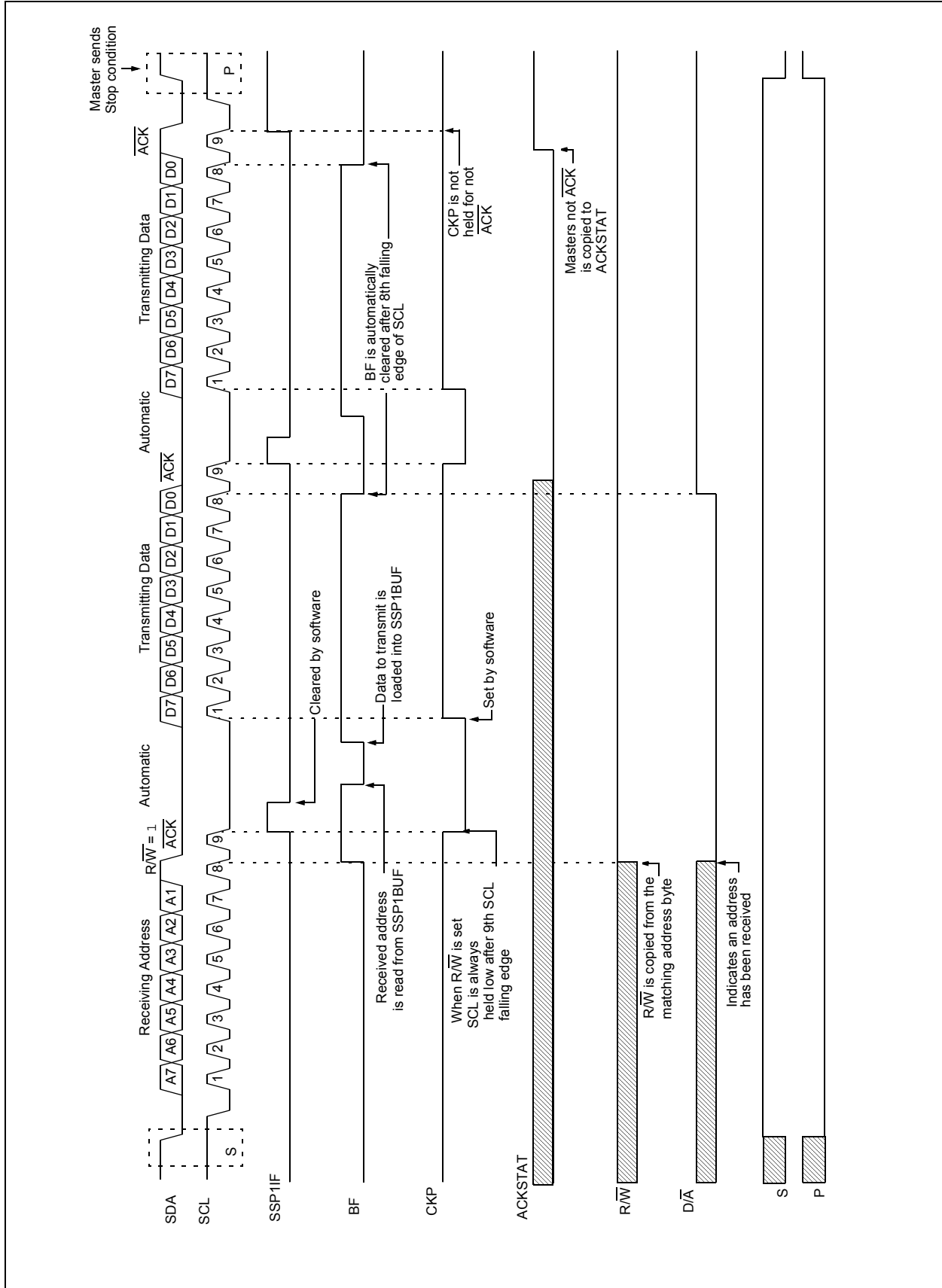
1. Master sends a Start condition on SDA and SCL.
2. S bit of SSP1STAT is set; SSP1IF is set if interrupt on Start detect is enabled.
3. Matching address with R/W bit set is received by the Slave setting SSP1IF bit.
4. Slave hardware generates an  $\overline{\text{ACK}}$  and sets SSP1IF.
5. SSP1IF bit is cleared by user.
6. Software reads the received address from SSP1BUF, clearing BF.
7.  $\overline{\text{R/W}}$  is set so CKP was automatically cleared after the  $\overline{\text{ACK}}$ .
8. The slave software loads the transmit data into SSP1BUF.
9. CKP bit is set releasing SCL, allowing the master to clock the data out of the slave.
10. SSP1IF is set after the  $\overline{\text{ACK}}$  response from the master is loaded into the ACKSTAT register.
11. SSP1IF bit is cleared.
12. The slave software checks the ACKSTAT bit to see if the master wants to clock out more data.

**Note 1:** If the master  $\overline{\text{ACK}}$ s the clock will be stretched.

**2:** ACKSTAT is the only bit updated on the rising edge of SCL (9th) rather than the falling.

13. Steps 9-13 are repeated for each transmitted byte.
14. If the master sends a not  $\overline{\text{ACK}}$ ; the clock is not held, but SSP1IF is still set.
15. The master sends a Restart condition or a Stop.
16. The slave is no longer addressed.

**FIGURE 30-18: I<sup>2</sup>C SLAVE, 7-BIT ADDRESS, TRANSMISSION (AHEN = 0)**



# PIC16(L)F1717/8/9

---

## 30.5.3.3 7-Bit Transmission with Address Hold Enabled

Setting the AHEN bit of the SSP1CON3 register enables additional clock stretching and interrupt generation after the eighth falling edge of a received matching address. Once a matching address has been clocked in, CKP is cleared and the SSP1IF interrupt is set.

Figure 30-19 displays a standard waveform of a 7-bit address slave transmission with AHEN enabled.

1. Bus starts Idle.
2. Master sends Start condition; the S bit of SSP1STAT is set; SSP1IF is set if interrupt on Start detect is enabled.
3. Master sends matching address with  $\overline{R/W}$  bit set. After the eighth falling edge of the SCL line the CKP bit is cleared and SSP1IF interrupt is generated.
4. Slave software clears SSP1IF.
5. Slave software reads ACKTIM bit of SSP1CON3 register, and  $\overline{R/W}$  and D/A of the SSP1STAT register to determine the source of the interrupt.
6. Slave reads the address value from the SSP1BUF register clearing the BF bit.
7. Slave software decides from this information if it wishes to ACK or not ACK and sets the ACKDT bit of the SSP1CON2 register accordingly.
8. Slave sets the CKP bit releasing SCL.
9. Master clocks in the  $\overline{ACK}$  value from the slave.
10. Slave hardware automatically clears the CKP bit and sets SSP1IF after the  $\overline{ACK}$  if the  $\overline{R/W}$  bit is set.
11. Slave software clears SSP1IF.
12. Slave loads value to transmit to the master into SSP1BUF setting the BF bit.

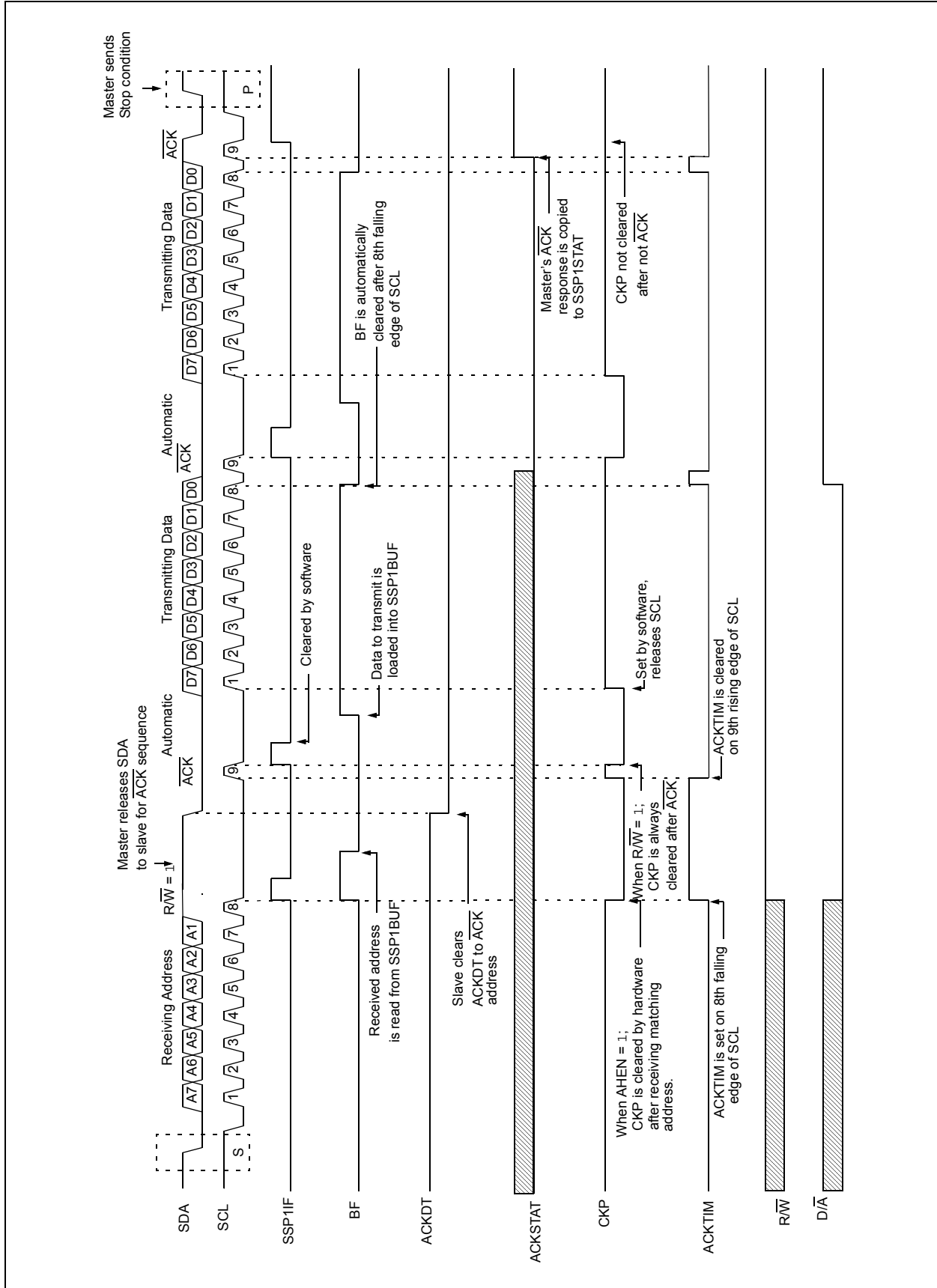
**Note:** SSP1BUF cannot be loaded until after the  $\overline{ACK}$ .

13. Slave sets the CKP bit releasing the clock.
14. Master clocks out the data from the slave and sends an  $\overline{ACK}$  value on the 9th SCL pulse.
15. Slave hardware copies the  $\overline{ACK}$  value into the ACKSTAT bit of the SSP1CON2 register.
16. Steps 10-15 are repeated for each byte transmitted to the master from the slave.
17. If the master sends a not  $\overline{ACK}$  the slave releases the bus allowing the master to send a Stop and end the communication.

**Note:** Master must send a not  $\overline{ACK}$  on the last byte to ensure that the slave releases the SCL line to receive a Stop.



**FIGURE 30-19: I<sup>2</sup>C SLAVE, 7-BIT ADDRESS, TRANSMISSION (AHEN = 1)**



# PIC16(L)F1717/8/9

---

## 30.5.4 SLAVE MODE 10-BIT ADDRESS RECEPTION

This section describes a standard sequence of events for the MSSP module configured as an I<sup>2</sup>C slave in 10-bit Addressing mode.

Figure 30-20 is used as a visual reference for this description.

This is a step by step process of what must be done by slave software to accomplish I<sup>2</sup>C communication.

1. Bus starts Idle.
2. Master sends Start condition; S bit of SSP1STAT is set; SSP1IF is set if interrupt on Start detect is enabled.
3. Master sends matching high address with  $\overline{R/\overline{W}}$  bit clear; UA bit of the SSP1STAT register is set.
4. Slave sends  $\overline{ACK}$  and SSP1IF is set.
5. Software clears the SSP1IF bit.
6. Software reads received address from SSP1BUF clearing the BF flag.
7. Slave loads low address into SSP1ADD, releasing SCL.
8. Master sends matching low address byte to the slave; UA bit is set.

**Note:** Updates to the SSP1ADD register are not allowed until after the  $\overline{ACK}$  sequence.

9. Slave sends  $\overline{ACK}$  and SSP1IF is set.

**Note:** If the low address does not match, SSP1IF and UA are still set so that the slave software can set SSP1ADD back to the high address. BF is not set because there is no match. CKP is unaffected.

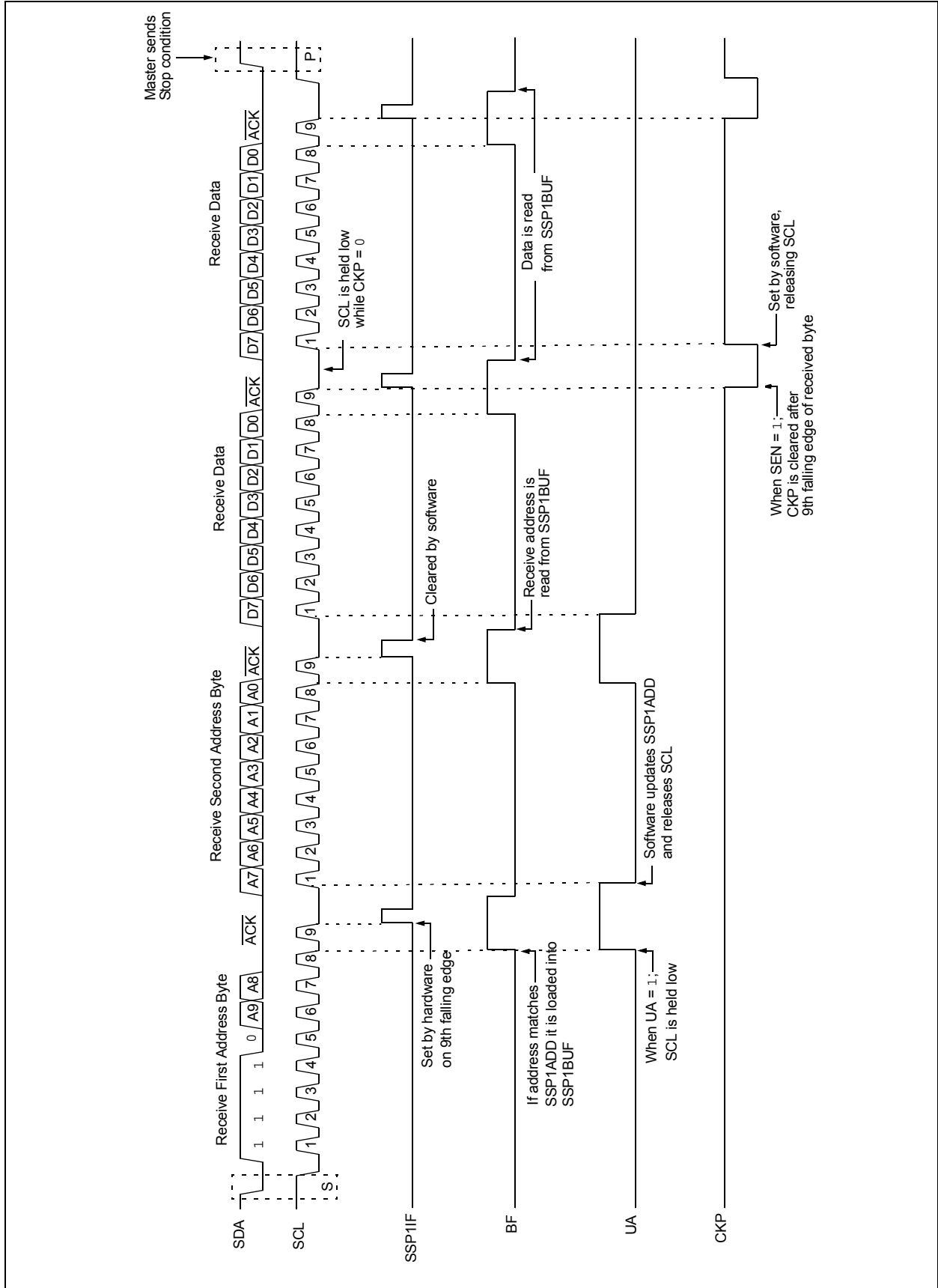
10. Slave clears SSP1IF.
11. Slave reads the received matching address from SSP1BUF clearing BF.
12. Slave loads high address into SSP1ADD.
13. Master clocks a data byte to the slave and clocks out the slaves  $\overline{ACK}$  on the 9th SCL pulse; SSP1IF is set.
14. If SEN bit of SSP1CON2 is set, CKP is cleared by hardware and the clock is stretched.
15. Slave clears SSP1IF.
16. Slave reads the received byte from SSP1BUF clearing BF.
17. If SEN is set the slave sets CKP to release the SCL.
18. Steps 13-17 repeat for each received byte.
19. Master sends Stop to end the transmission.

## 30.5.5 10-BIT ADDRESSING WITH ADDRESS OR DATA HOLD

Reception using 10-bit addressing with AHEN or DHEN set is the same as with 7-bit modes. The only difference is the need to update the SSP1ADD register using the UA bit. All functionality, specifically when the CKP bit is cleared and SCL line is held low are the same. Figure 30-21 can be used as a reference of a slave in 10-bit addressing with AHEN set.

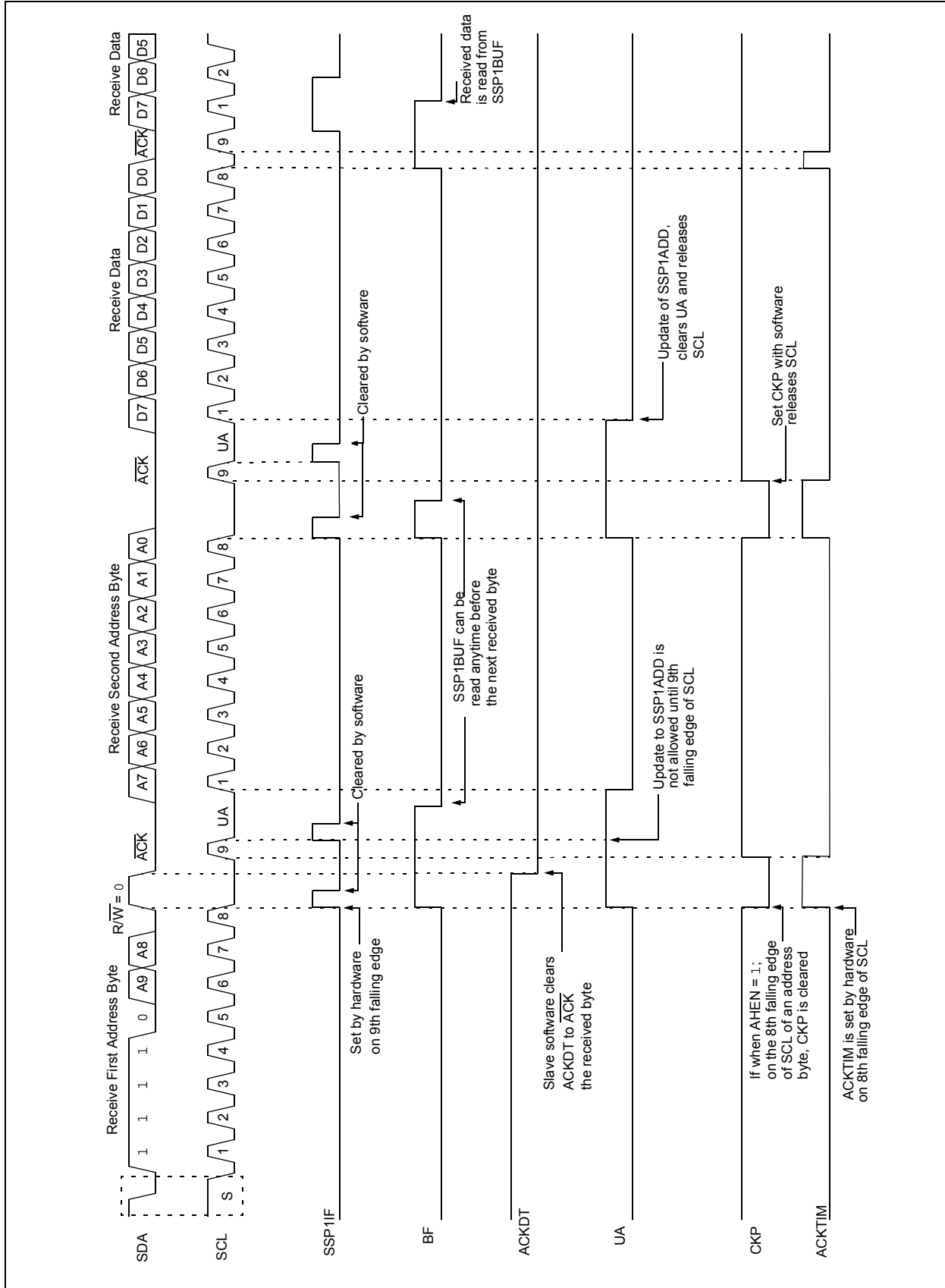
Figure 30-22 shows a standard waveform for a slave transmitter in 10-bit Addressing mode.

**FIGURE 30-20: I<sup>2</sup>C SLAVE, 10-BIT ADDRESS, RECEPTION (SEN = 1, AHEN = 0, DHEN = 0)**

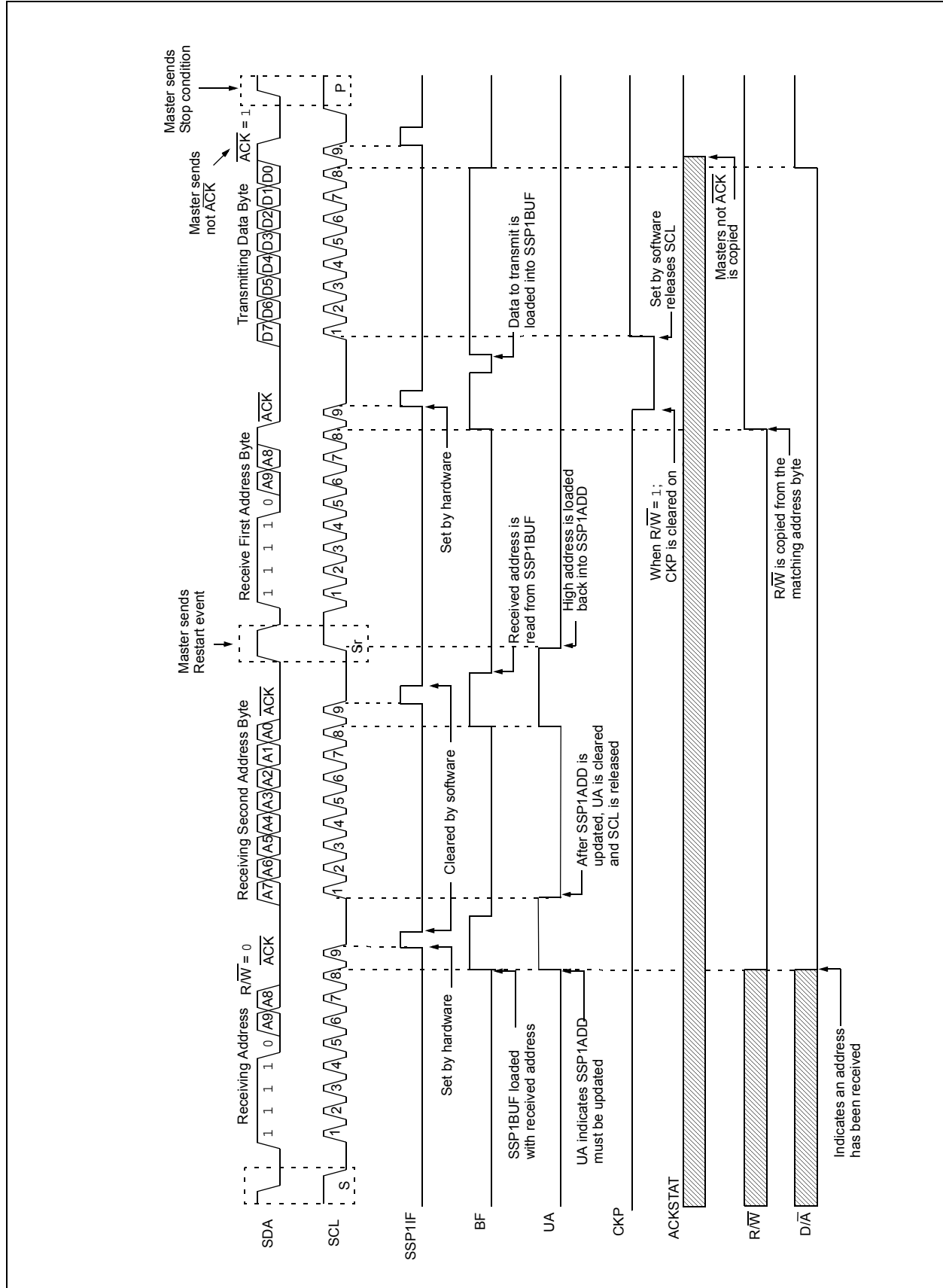


# PIC16(L)F1717/8/9

FIGURE 30-21: I<sup>2</sup>C SLAVE, 10-BIT ADDRESS, RECEPTION (SEN = 0, AHEN = 1, DHEN = 0)



**FIGURE 30-22: I<sup>2</sup>C SLAVE, 10-BIT ADDRESS, TRANSMISSION (SEN = 0, AHEN = 0, DHEN = 0)**



# PIC16(L)F1717/8/9

---

## 30.5.6 CLOCK STRETCHING

Clock stretching occurs when a device on the bus holds the SCL line low, effectively pausing communication. The slave may stretch the clock to allow more time to handle data or prepare a response for the master device. A master device is not concerned with stretching as anytime it is active on the bus and not transferring data it is stretching. Any stretching done by a slave is invisible to the master software and handled by the hardware that generates SCL.

The CKP bit of the SSP1CON1 register is used to control stretching in software. Any time the CKP bit is cleared, the module will wait for the SCL line to go low and then hold it. Setting CKP will release SCL and allow more communication.

### 30.5.6.1 Normal Clock Stretching

Following an  $\overline{\text{ACK}}$  if the  $\overline{\text{R}/\overline{\text{W}}}$  bit of SSP1STAT is set, a read request, the slave hardware will clear CKP. This allows the slave time to update SSP1BUF with data to transfer to the master. If the SEN bit of SSP1CON2 is set, the slave hardware will always stretch the clock after the ACK sequence. Once the slave is ready; CKP is set by software and communication resumes.

**Note 1:** The BF bit has no effect on if the clock will be stretched or not. This is different than previous versions of the module that would not stretch the clock, clear CKP, if SSP1BUF was read before the 9th falling edge of SCL.

**2:** Previous versions of the module did not stretch the clock for a transmission if SSP1BUF was loaded before the 9th falling edge of SCL. It is now always cleared for read requests.

### 30.5.6.2 10-Bit Addressing Mode

In 10-bit Addressing mode, when the UA bit is set the clock is always stretched. This is the only time the SCL is stretched without CKP being cleared. SCL is released immediately after a write to SSP1ADD.

**Note:** Previous versions of the module did not stretch the clock if the second address byte did not match.

### 30.5.6.3 Byte NACKing

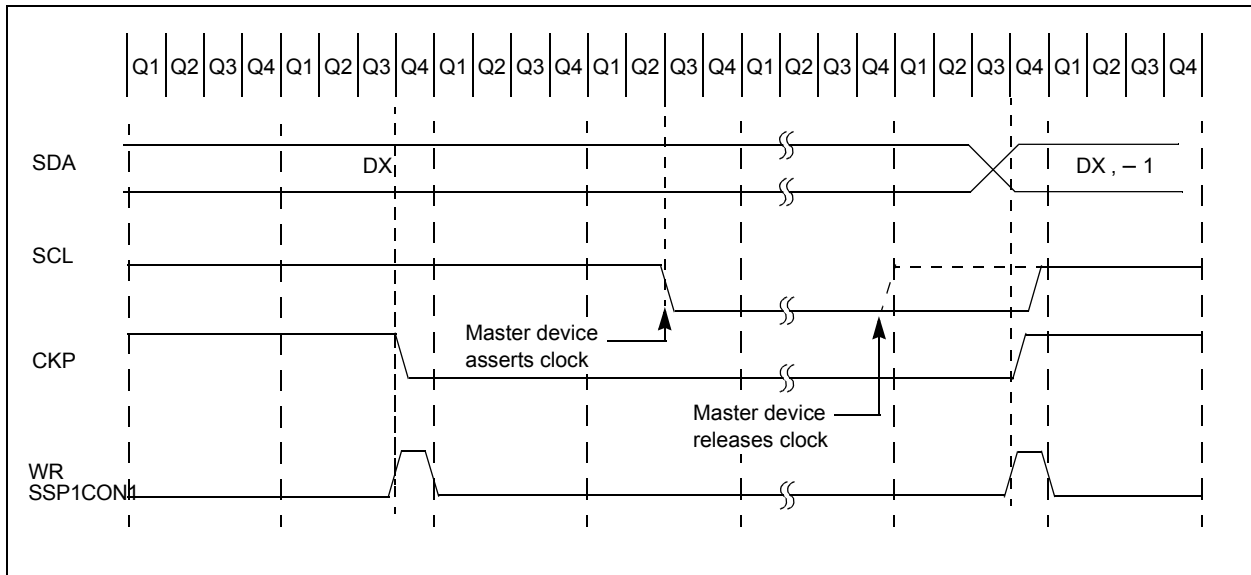
When AHEN bit of SSP1CON3 is set; CKP is cleared by hardware after the eighth falling edge of SCL for a received matching address byte. When DHEN bit of SSP1CON3 is set; CKP is cleared after the eighth falling edge of SCL for received data.

Stretching after the eighth falling edge of SCL allows the slave to look at the received address or data and decide if it wants to ACK the received data.

## 30.5.7 CLOCK SYNCHRONIZATION AND THE CKP BIT

Any time the CKP bit is cleared, the module will wait for the SCL line to go low and then hold it. However, clearing the CKP bit will not assert the SCL output low until the SCL output is already sampled low. Therefore, the CKP bit will not assert the SCL line until an external I<sup>2</sup>C master device has already asserted the SCL line. The SCL output will remain low until the CKP bit is set and all other devices on the I<sup>2</sup>C bus have released SCL. This ensures that a write to the CKP bit will not violate the minimum high time requirement for SCL (see [Figure 30-23](#)).

**FIGURE 30-23: CLOCK SYNCHRONIZATION TIMING**



# PIC16(L)F1717/8/9

## 30.5.8 GENERAL CALL ADDRESS SUPPORT

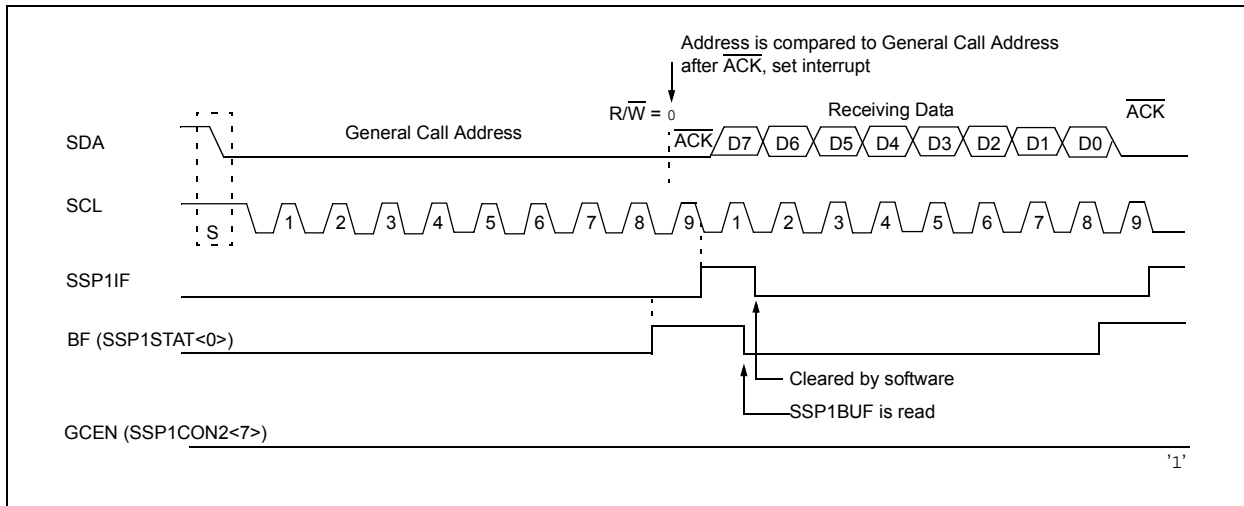
The addressing procedure for the I<sup>2</sup>C bus is such that the first byte after the Start condition usually determines which device will be the slave addressed by the master device. The exception is the general call address which can address all devices. When this address is used, all devices should, in theory, respond with an acknowledge.

The general call address is a reserved address in the I<sup>2</sup>C protocol, defined as address 0x00. When the GCEN bit of the SSP1CON2 register is set, the slave module will automatically  $\overline{\text{ACK}}$  the reception of this address regardless of the value stored in SSP1ADD. After the slave clocks in an address of all zeros with the R/W bit clear, an interrupt is generated and slave software can read SSP1BUF and respond. Figure 30-24 shows a general call reception sequence.

In 10-bit Address mode, the UA bit will not be set on the reception of the general call address. The slave will prepare to receive the second byte as data, just as it would in 7-bit mode.

If the AHEN bit of the SSP1CON3 register is set, just as with any other address reception, the slave hardware will stretch the clock after the eighth falling edge of SCL. The slave must then set its ACKDT value and release the clock with communication progressing as it would normally.

**FIGURE 30-24: SLAVE MODE GENERAL CALL ADDRESS SEQUENCE**



## 30.5.9 SSP MASK REGISTER

An SSP Mask (SSP1MSK) register (Register 30-5) is available in I<sup>2</sup>C Slave mode as a mask for the value held in the SSP1SR register during an address comparison operation. A zero ('0') bit in the SSP1MSK register has the effect of making the corresponding bit of the received address a "don't care".

This register is reset to all '1's upon any Reset condition and, therefore, has no effect on standard SSP operation until written with a mask value.

The SSP Mask register is active during:

- 7-bit Address mode: address compare of SSP1ADD<7:1>.
- 10-bit Address mode: address compare of SSP1ADD<7:0> only. The SSP mask has no effect during the reception of the first (high) byte of the address.



## 30.6 I<sup>2</sup>C Master Mode

Master mode is enabled by setting and clearing the appropriate SSPM bits in the SSP1CON1 register and by setting the SSPEN bit. In Master mode, the SDA and SCK pins must be configured as inputs. The MSSP peripheral hardware will override the output driver TRIS controls when necessary to drive the pins low.

Master mode of operation is supported by interrupt generation on the detection of the Start and Stop conditions. The Stop (P) and Start (S) bits are cleared from a Reset or when the MSSP module is disabled. Control of the I<sup>2</sup>C bus may be taken when the P bit is set, or the bus is Idle.

In Firmware Controlled Master mode, user code conducts all I<sup>2</sup>C bus operations based on Start and Stop bit condition detection. Start and Stop condition detection is the only active circuitry in this mode. All other communication is done by the user software directly manipulating the SDA and SCL lines.

The following events will cause the SSP Interrupt Flag bit, SSP1IF, to be set (SSP interrupt, if enabled):

- Start condition detected
- Stop condition detected
- Data transfer byte transmitted/received
- Acknowledge transmitted/received
- Repeated Start generated

**Note 1:** The MSSP module, when configured in I<sup>2</sup>C Master mode, does not allow queuing of events. For instance, the user is not allowed to initiate a Start condition and immediately write the SSP1BUF register to initiate transmission before the Start condition is complete. In this case, the SSP1BUF will not be written to and the WCOL bit will be set, indicating that a write to the SSP1BUF did not occur

**2:** Master mode suspends Start/Stop detection when sending the Start/Stop condition by means of the SEN/PEN control bits. The SSPxIF bit is set at the end of the Start/Stop generation when hardware clears the control bit.

### 30.6.1 I<sup>2</sup>C MASTER MODE OPERATION

The master device generates all of the serial clock pulses and the Start and Stop conditions. A transfer is ended with a Stop condition or with a Repeated Start condition. Since the Repeated Start condition is also the beginning of the next serial transfer, the I<sup>2</sup>C bus will not be released.

In Master Transmitter mode, serial data is output through SDA, while SCL outputs the serial clock. The first byte transmitted contains the slave address of the receiving device (7 bits) and the Read/Write (R/W) bit. In this case, the R/W bit will be logic '0'. Serial data is transmitted eight bits at a time. After each byte is transmitted, an Acknowledge bit is received. Start and Stop conditions are output to indicate the beginning and the end of a serial transfer.

In Master Receive mode, the first byte transmitted contains the slave address of the transmitting device (7 bits) and the R/W bit. In this case, the R/W bit will be logic '1'. Thus, the first byte transmitted is a 7-bit slave address followed by a '1' to indicate the receive bit. Serial data is received via SDA, while SCL outputs the serial clock. Serial data is received eight bits at a time. After each byte is received, an Acknowledge bit is transmitted. Start and Stop conditions indicate the beginning and end of transmission.

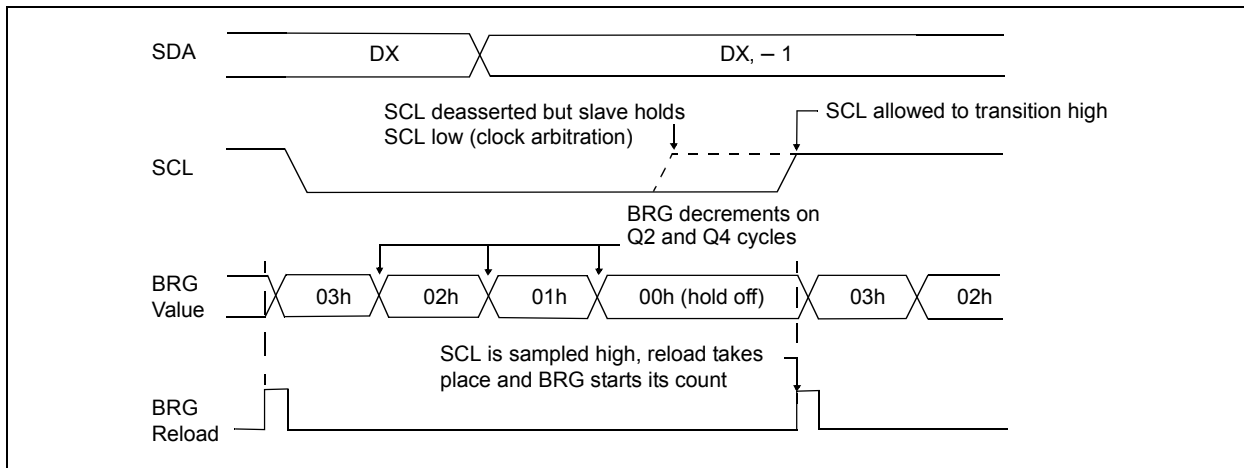
A Baud Rate Generator is used to set the clock frequency output on SCL. See [Section 30.7 “Baud Rate Generator”](#) for more detail.

# PIC16(L)F1717/8/9

## 30.6.2 CLOCK ARBITRATION

Clock arbitration occurs when the master, during any receive, transmit or Repeated Start/Stop condition, releases the SCL pin (SCL allowed to float high). When the SCL pin is allowed to float high, the Baud Rate Generator (BRG) is suspended from counting until the SCL pin is actually sampled high. When the SCL pin is sampled high, the Baud Rate Generator is reloaded with the contents of SSP1ADD<7:0> and begins counting. This ensures that the SCL high time will always be at least one BRG rollover count in the event that the clock is held low by an external device (Figure 30-25).

**FIGURE 30-25: BAUD RATE GENERATOR TIMING WITH CLOCK ARBITRATION**



## 30.6.3 WCOL STATUS FLAG

If the user writes the SSP1BUF when a Start, Restart, Stop, Receive or Transmit sequence is in progress, the WCOL is set and the contents of the buffer are unchanged (the write does not occur). Any time the WCOL bit is set it indicates that an action on SSP1BUF was attempted while the module was not idle.

**Note:** Because queuing of events is not allowed, writing to the lower five bits of SSP1CON2 is disabled until the Start condition is complete.

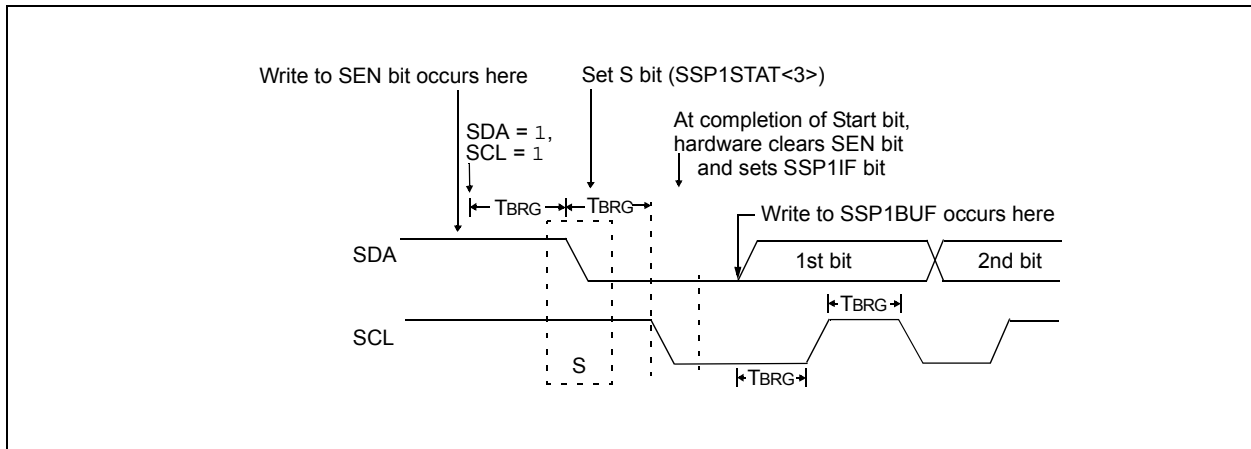
## 30.6.4 I<sup>2</sup>C MASTER MODE START CONDITION TIMING

To initiate a Start condition (Figure 30-26), the user sets the Start Enable bit, SEN bit of the SSP1CON2 register. If the SDA and SCL pins are sampled high, the Baud Rate Generator is reloaded with the contents of SSP1ADD<7:0> and starts its count. If SCL and SDA are both sampled high when the Baud Rate Generator times out (TBRG), the SDA pin is driven low. The action of the SDA being driven low while SCL is high is the Start condition and causes the S bit of the SSP1STAT register to be set. Following this, the Baud Rate Generator is reloaded with the contents of SSP1ADD<7:0> and resumes its count. When the Baud Rate Generator times out (TBRG), the SEN bit of the SSP1CON2 register will be automatically cleared by hardware; the Baud Rate Generator is suspended, leaving the SDA line held low and the Start condition is complete.

**Note 1:** If at the beginning of the Start condition, the SDA and SCL pins are already sampled low, or if during the Start condition, the SCL line is sampled low before the SDA line is driven low, a bus collision occurs, the Bus Collision Interrupt Flag, BCL1IF, is set, the Start condition is aborted and the I<sup>2</sup>C module is reset into its Idle state.

**2:** The Philips I<sup>2</sup>C specification states that a bus collision cannot occur on a Start.

**FIGURE 30-26: FIRST START BIT TIMING**



# PIC16(L)F1717/8/9

## 30.6.5 I<sup>2</sup>C MASTER MODE REPEATED START CONDITION TIMING

A Repeated Start condition (Figure 30-27) occurs when the RSEN bit of the SSP1CON2 register is programmed high and the master state machine is no longer active. When the RSEN bit is set, the SCL pin is asserted low. When the SCL pin is sampled low, the Baud Rate Generator is loaded and begins counting. The SDA pin is released (brought high) for one Baud Rate Generator count (TBRG). When the Baud Rate Generator times out, if SDA is sampled high, the SCL pin will be deasserted (brought high). When SCL is sampled high, the Baud Rate Generator is reloaded and begins counting. SDA and SCL must be sampled high for one TBRG. This action is then followed by assertion of the SDA pin (SDA = 0) for one TBRG while SCL is high. SCL is asserted low. Following this, the RSEN bit of the SSP1CON2 register will be automatically cleared and the Baud Rate Generator will not be reloaded, leaving the SDA pin held low. As soon as a Start condition is detected on the SDA and SCL

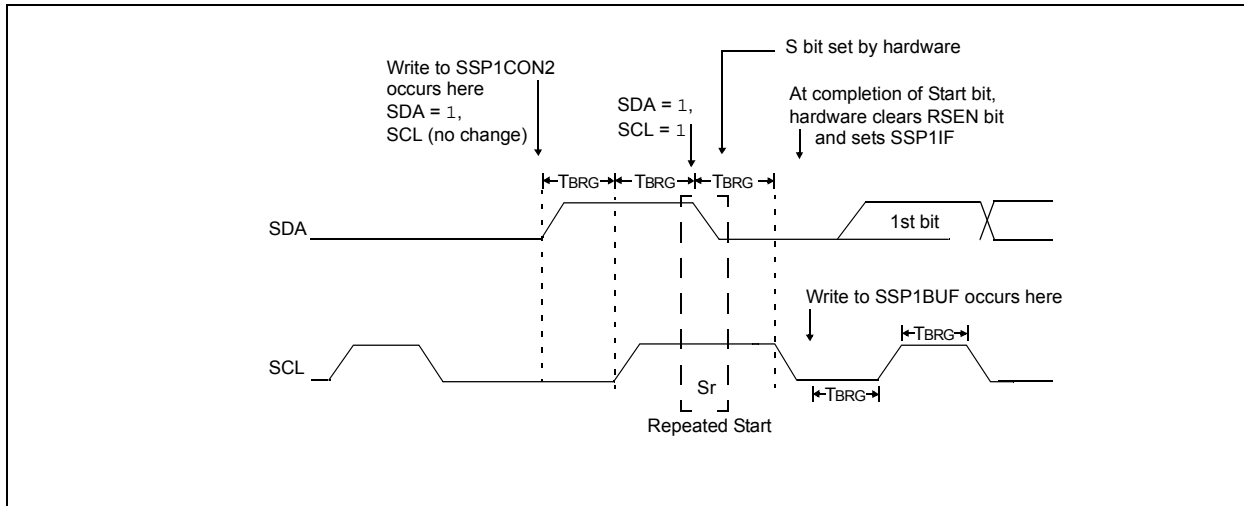
pins, the S bit of the SSP1STAT register will be set. The SSP1IF bit will not be set until the Baud Rate Generator has timed out.

**Note 1:** If RSEN is programmed while any other event is in progress, it will not take effect.

**2:** A bus collision during the Repeated Start condition occurs if:

- SDA is sampled low when SCL goes from low-to-high.
- SCL goes low before SDA is asserted low. This may indicate that another master is attempting to transmit a data '1'.

**FIGURE 30-27: REPEATED START CONDITION WAVEFORM**



## 30.6.6 I<sup>2</sup>C MASTER MODE TRANSMISSION

Transmission of a data byte, a 7-bit address or the other half of a 10-bit address is accomplished by simply writing a value to the SSP1BUF register. This action will set the Buffer Full flag bit, BF, and allow the Baud Rate Generator to begin counting and start the next transmission. Each bit of address/data will be shifted out onto the SDA pin after the falling edge of SCL is asserted. SCL is held low for one Baud Rate Generator rollover count (TBRG). Data should be valid before SCL is released high. When the SCL pin is released high, it is held that way for TBRG. The data on the SDA pin must remain stable for that duration and some hold time after the next falling edge of SCL. After the eighth bit is shifted out (the falling edge of the eighth clock), the BF flag is cleared and the master releases SDA. This allows the slave device being addressed to respond with an  $\overline{\text{ACK}}$  bit during the ninth bit time if an address match occurred, or if data was received properly. The status of  $\overline{\text{ACK}}$  is written into the ACKSTAT bit on the rising edge of the ninth clock. If the master receives an Acknowledge, the Acknowledge Status bit, ACKSTAT, is cleared. If not, the bit is set. After the ninth clock, the SSP1IF bit is set and the master clock (Baud Rate Generator) is suspended until the next data byte is loaded into the SSP1BUF, leaving SCL low and SDA unchanged (Figure 30-28).

After the write to the SSP1BUF, each bit of the address will be shifted out on the falling edge of SCL until all seven address bits and the R/W bit are completed. On the falling edge of the eighth clock, the master will release the SDA pin, allowing the slave to respond with an Acknowledge. On the falling edge of the ninth clock, the master will sample the SDA pin to see if the address was recognized by a slave. The status of the  $\overline{\text{ACK}}$  bit is loaded into the ACKSTAT Status bit of the SSP1CON2 register. Following the falling edge of the ninth clock transmission of the address, the SSP1IF is set, the BF flag is cleared and the Baud Rate Generator is turned off until another write to the SSP1BUF takes place, holding SCL low and allowing SDA to float.

### 30.6.6.1 BF Status Flag

In Transmit mode, the BF bit of the SSP1STAT register is set when the CPU writes to SSP1BUF and is cleared when all eight bits are shifted out.

### 30.6.6.2 WCOL Status Flag

If the user writes the SSP1BUF when a transmit is already in progress (i.e., SSP1SR is still shifting out a data byte), the WCOL bit is set and the contents of the buffer are unchanged (the write does not occur).

WCOL must be cleared by software before the next transmission.

### 30.6.6.3 ACKSTAT Status Flag

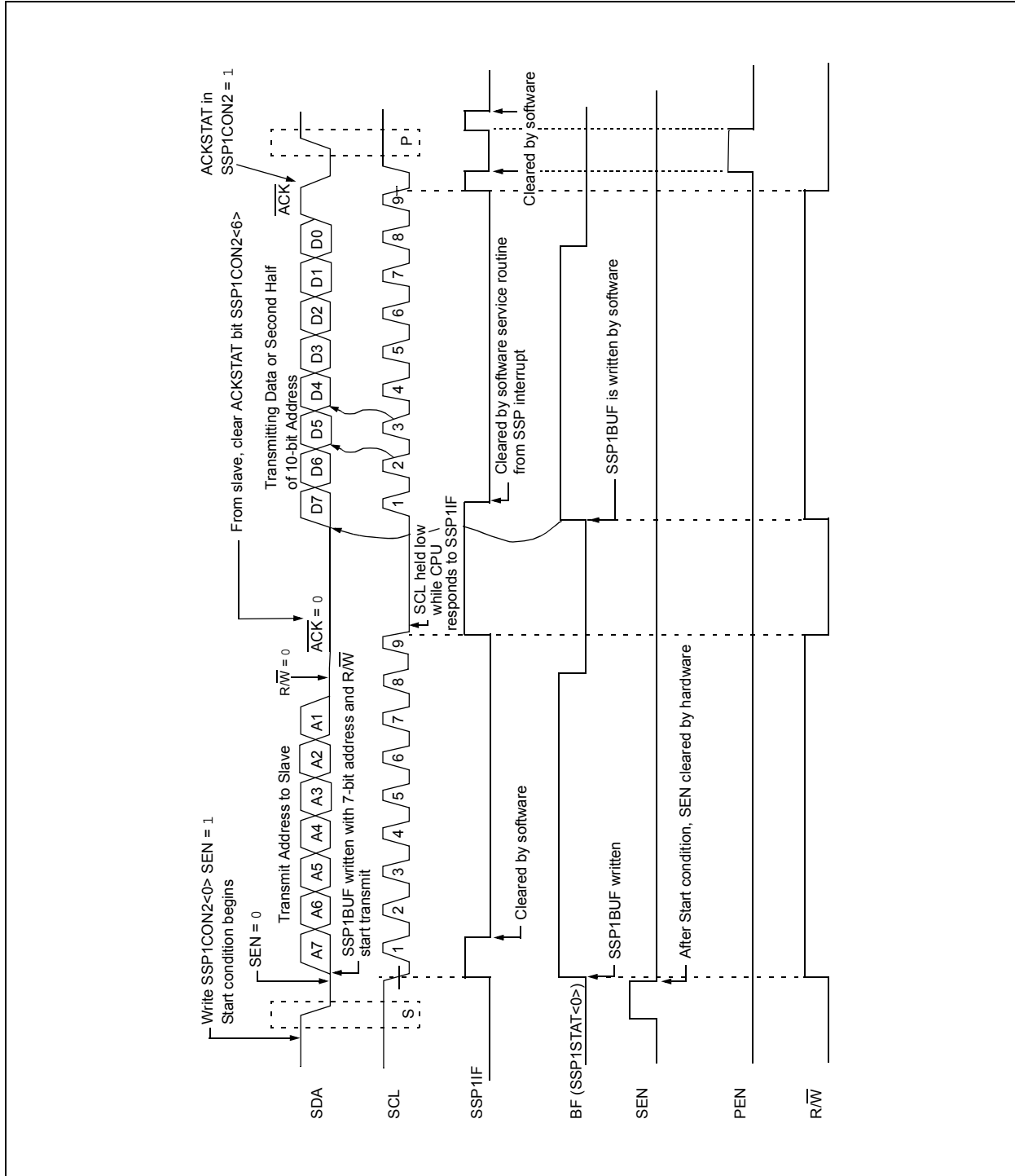
In Transmit mode, the ACKSTAT bit of the SSP1CON2 register is cleared when the slave has sent an Acknowledge ( $\text{ACK} = 0$ ) and is set when the slave does not Acknowledge ( $\text{ACK} = 1$ ). A slave sends an Acknowledge when it has recognized its address (including a general call), or when the slave has properly received its data.

### 30.6.6.4 Typical Transmit Sequence

1. The user generates a Start condition by setting the SEN bit of the SSP1CON2 register.
2. SSP1IF is set by hardware on completion of the Start.
3. SSP1IF is cleared by software.
4. The MSSP module will wait the required start time before any other operation takes place.
5. The user loads the SSP1BUF with the slave address to transmit.
6. Address is shifted out the SDA pin until all eight bits are transmitted. Transmission begins as soon as SSP1BUF is written to.
7. The MSSP module shifts in the  $\overline{\text{ACK}}$  bit from the slave device and writes its value into the ACKSTAT bit of the SSP1CON2 register.
8. The MSSP module generates an interrupt at the end of the ninth clock cycle by setting the SSP1IF bit.
9. The user loads the SSP1BUF with eight bits of data.
10. Data is shifted out the SDA pin until all eight bits are transmitted.
11. The MSSP module shifts in the  $\overline{\text{ACK}}$  bit from the slave device and writes its value into the ACKSTAT bit of the SSP1CON2 register.
12. Steps 8-11 are repeated for all transmitted data bytes.
13. The user generates a Stop or Restart condition by setting the PEN or RSEN bits of the SSP1CON2 register. Interrupt is generated once the Stop/Restart condition is complete.

# PIC16(L)F1717/8/9

FIGURE 30-28: I<sup>2</sup>C MASTER MODE WAVEFORM (TRANSMISSION, 7 OR 10-BIT ADDRESS)



## 30.6.7 I<sup>2</sup>C MASTER MODE RECEPTION

Master mode reception (Figure 30-29) is enabled by programming the Receive Enable bit, RCEN bit of the SSP1CON2 register.

**Note:** The MSSP module must be in an Idle state before the RCEN bit is set or the RCEN bit will be disregarded.

The Baud Rate Generator begins counting and on each rollover, the state of the SCL pin changes (high-to-low/low-to-high) and data is shifted into the SSP1SR. After the falling edge of the eighth clock, the receive enable flag is automatically cleared, the contents of the SSP1SR are loaded into the SSP1BUF, the BF flag bit is set, the SSP1IF flag bit is set and the Baud Rate Generator is suspended from counting, holding SCL low. The MSSP is now in Idle state awaiting the next command. When the buffer is read by the CPU, the BF flag bit is automatically cleared. The user can then send an Acknowledge bit at the end of reception by setting the Acknowledge Sequence Enable, ACKEN bit of the SSP1CON2 register.

### 30.6.7.1 BF Status Flag

In receive operation, the BF bit is set when an address or data byte is loaded into SSP1BUF from SSP1SR. It is cleared when the SSP1BUF register is read.

### 30.6.7.2 SSPOV Status Flag

In receive operation, the SSPOV bit is set when eight bits are received into the SSP1SR and the BF flag bit is already set from a previous reception.

### 30.6.7.3 WCOL Status Flag

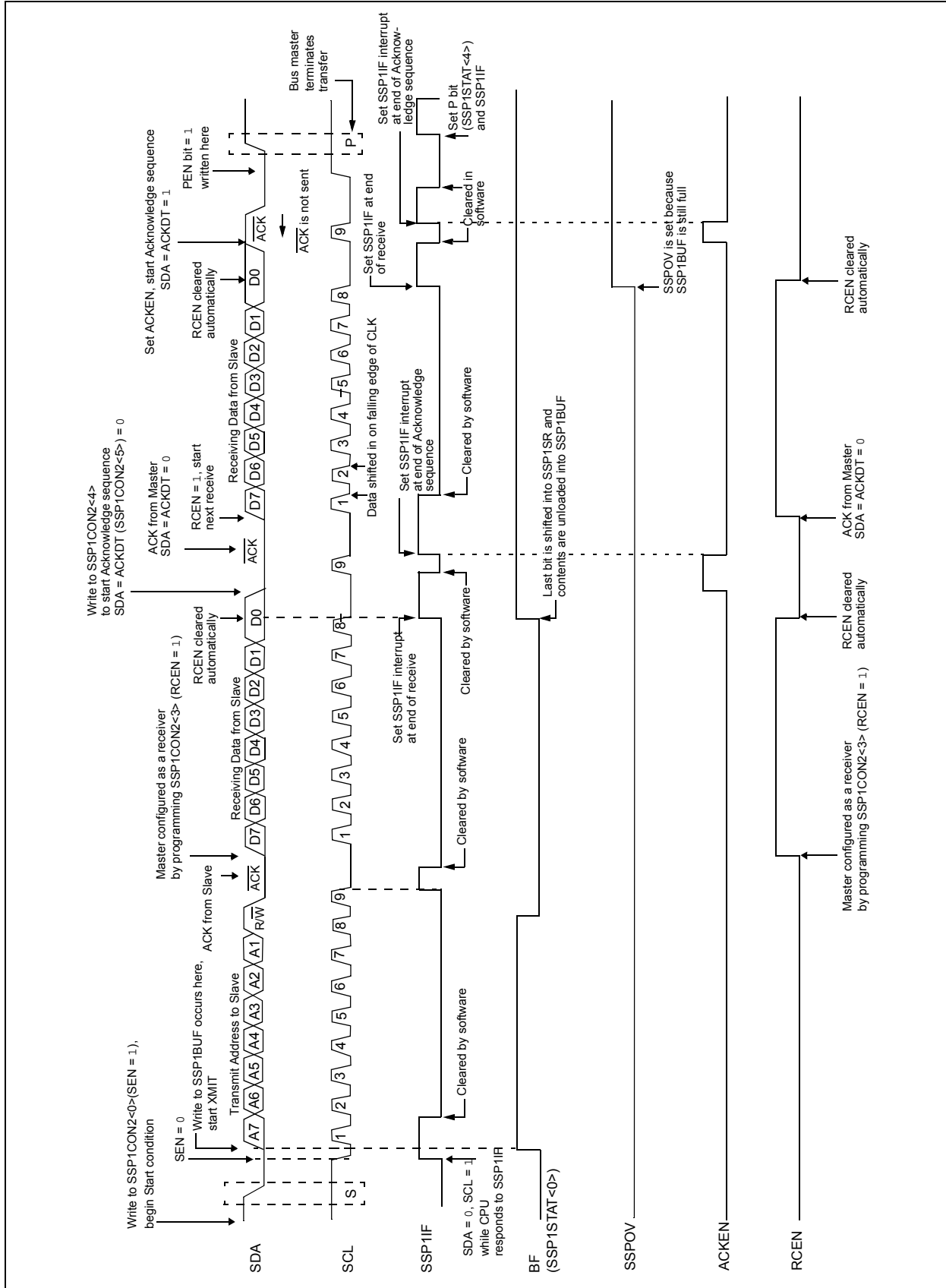
If the user writes the SSP1BUF when a receive is already in progress (i.e., SSP1SR is still shifting in a data byte), the WCOL bit is set and the contents of the buffer are unchanged (the write does not occur).

### 30.6.7.4 Typical Receive Sequence

1. The user generates a Start condition by setting the SEN bit of the SSP1CON2 register.
2. SSP1IF is set by hardware on completion of the Start.
3. SSP1IF is cleared by software.
4. User writes SSP1BUF with the slave address to transmit and the R/W bit set.
5. Address is shifted out the SDA pin until all eight bits are transmitted. Transmission begins as soon as SSP1BUF is written to.
6. The MSSP module shifts in the  $\overline{\text{ACK}}$  bit from the slave device and writes its value into the ACKSTAT bit of the SSP1CON2 register.
7. The MSSP module generates an interrupt at the end of the ninth clock cycle by setting the SSP1IF bit.
8. User sets the RCEN bit of the SSP1CON2 register and the master clocks in a byte from the slave.
9. After the eighth falling edge of SCL, SSP1IF and BF are set.
10. Master clears SSP1IF and reads the received byte from SSP1BUF, clears BF.
11. Master sets  $\overline{\text{ACK}}$  value sent to slave in ACKDT bit of the SSP1CON2 register and initiates the  $\overline{\text{ACK}}$  by setting the ACKEN bit.
12. Master's  $\overline{\text{ACK}}$  is clocked out to the slave and SSP1IF is set.
13. User clears SSP1IF.
14. Steps 8-13 are repeated for each received byte from the slave.
15. Master sends a not  $\overline{\text{ACK}}$  or Stop to end communication.

# PIC16(L)F1717/8/9

FIGURE 30-29: I<sup>2</sup>C MASTER MODE WAVEFORM (RECEPTION, 7-BIT ADDRESS)





## 30.6.8 ACKNOWLEDGE SEQUENCE TIMING

An Acknowledge sequence is enabled by setting the Acknowledge Sequence Enable bit, ACKEN bit of the SSP1CON2 register. When this bit is set, the SCL pin is pulled low and the contents of the Acknowledge data bit are presented on the SDA pin. If the user wishes to generate an Acknowledge, then the ACKDT bit should be cleared. If not, the user should set the ACKDT bit before starting an Acknowledge sequence. The Baud Rate Generator then counts for one rollover period (TBRG) and the SCL pin is deasserted (pulled high). When the SCL pin is sampled high (clock arbitration), the Baud Rate Generator counts for TBRG. The SCL pin is then pulled low. Following this, the ACKEN bit is automatically cleared, the Baud Rate Generator is turned off and the MSSP module then goes into Idle mode (Figure 30-30).

### 30.6.8.1 WCOL Status Flag

If the user writes the SSP1BUF when an Acknowledge sequence is in progress, then WCOL bit is set and the contents of the buffer are unchanged (the write does not occur).

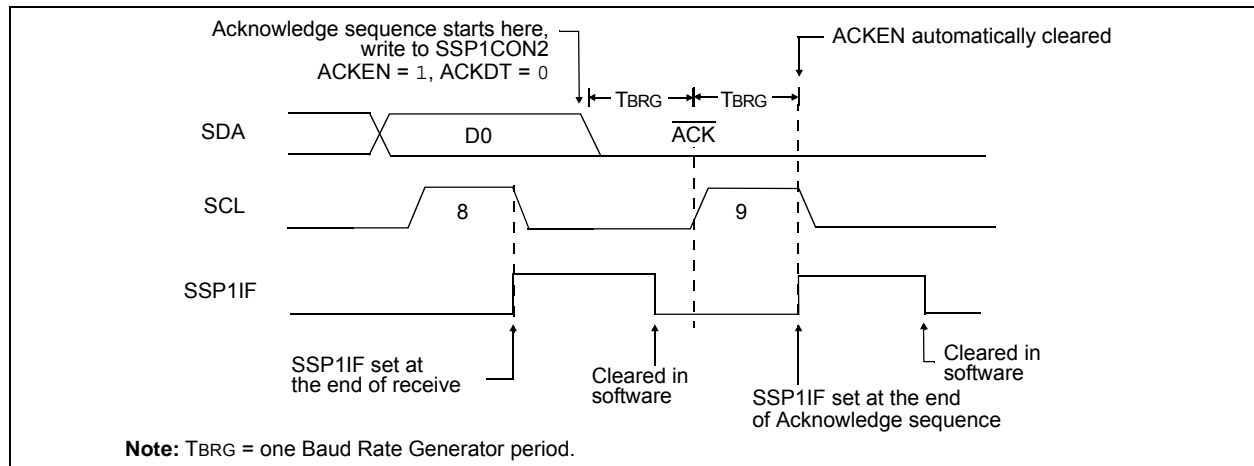
## 30.6.9 STOP CONDITION TIMING

A Stop bit is asserted on the SDA pin at the end of a receive/transmit by setting the Stop Sequence Enable bit, PEN bit of the SSP1CON2 register. At the end of a receive/transmit, the SCL line is held low after the falling edge of the ninth clock. When the PEN bit is set, the master will assert the SDA line low. When the SDA line is sampled low, the Baud Rate Generator is reloaded and counts down to '0'. When the Baud Rate Generator times out, the SCL pin will be brought high and one TBRG (Baud Rate Generator rollover count) later, the SDA pin will be deasserted. When the SDA pin is sampled high while SCL is high, the P bit of the SSP1STAT register is set. A TBRG later, the PEN bit is cleared and the SSP1IF bit is set (Figure 30-31).

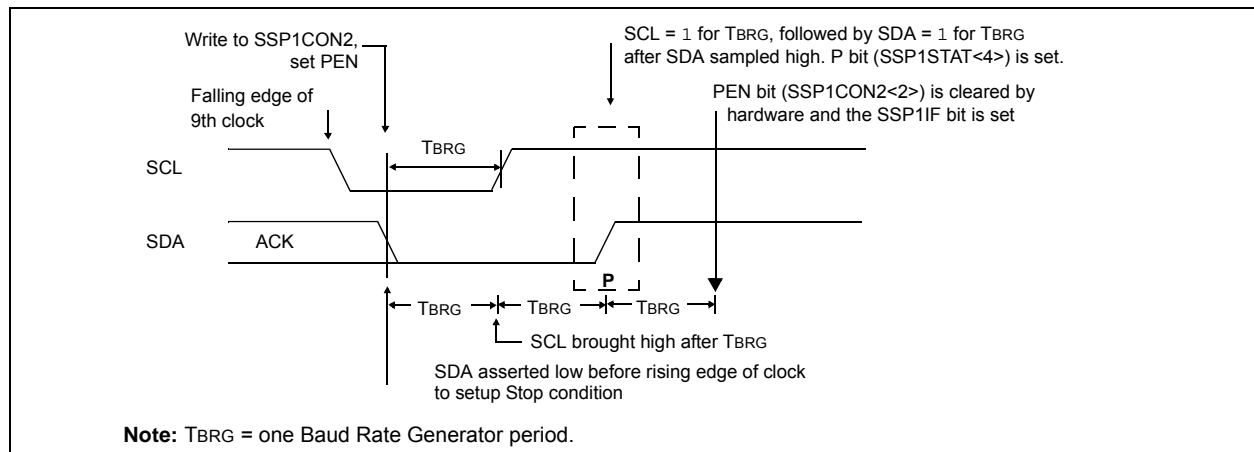
### 30.6.9.1 WCOL Status Flag

If the user writes the SSP1BUF when a Stop sequence is in progress, then the WCOL bit is set and the contents of the buffer are unchanged (the write does not occur).

**FIGURE 30-30: ACKNOWLEDGE SEQUENCE WAVEFORM**



**FIGURE 30-31: STOP CONDITION RECEIVE OR TRANSMIT MODE**



# PIC16(L)F1717/8/9

## 30.6.10 SLEEP OPERATION

While in Sleep mode, the I<sup>2</sup>C slave module can receive addresses or data and when an address match or complete byte transfer occurs, wake the processor from Sleep (if the MSSP interrupt is enabled).

## 30.6.11 EFFECTS OF A RESET

A Reset disables the MSSP module and terminates the current transfer.

## 30.6.12 MULTI-MASTER MODE

In Multi-Master mode, the interrupt generation on the detection of the Start and Stop conditions allows the determination of when the bus is free. The Stop (P) and Start (S) bits are cleared from a Reset or when the MSSP module is disabled. Control of the I<sup>2</sup>C bus may be taken when the P bit of the SSP1STAT register is set, or the bus is Idle, with both the S and P bits clear. When the bus is busy, enabling the SSP interrupt will generate the interrupt when the Stop condition occurs.

In multi-master operation, the SDA line must be monitored for arbitration to see if the signal level is the expected output level. This check is performed by hardware with the result placed in the BCL1IF bit.

The states where arbitration can be lost are:

- Address Transfer
- Data Transfer
- A Start Condition
- A Repeated Start Condition
- An Acknowledge Condition

## 30.6.13 MULTI-MASTER COMMUNICATION, BUS COLLISION AND BUS ARBITRATION

Multi-Master mode support is achieved by bus arbitration. When the master outputs address/data bits onto the SDA pin, arbitration takes place when the master outputs a '1' on SDA, by letting SDA float high and another master asserts a '0'. When the SCL pin floats high, data should be stable. If the expected data on SDA is a '1' and the data sampled on the SDA pin is '0', then a bus collision has taken place. The master will set the Bus Collision Interrupt Flag, BCL1IF and reset the I<sup>2</sup>C port to its Idle state (Figure 30-32).

If a transmit was in progress when the bus collision occurred, the transmission is halted, the BF flag is cleared, the SDA and SCL lines are deasserted and the SSP1BUF can be written to. When the user services the bus collision Interrupt Service Routine and if the I<sup>2</sup>C bus is free, the user can resume communication by asserting a Start condition.

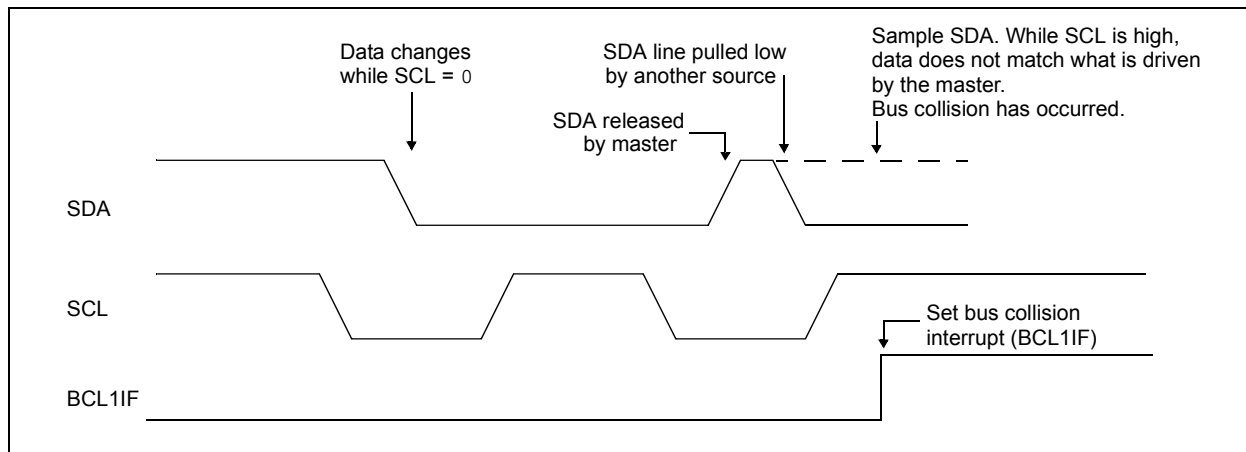
If a Start, Repeated Start, Stop or Acknowledge condition was in progress when the bus collision occurred, the condition is aborted, the SDA and SCL lines are deasserted and the respective control bits in the SSP1CON2 register are cleared. When the user services the bus collision Interrupt Service Routine and if the I<sup>2</sup>C bus is free, the user can resume communication by asserting a Start condition.

The master will continue to monitor the SDA and SCL pins. If a Stop condition occurs, the SSP1IF bit will be set.

A write to the SSP1BUF will start the transmission of data at the first data bit, regardless of where the transmitter left off when the bus collision occurred.

In Multi-Master mode, the interrupt generation on the detection of Start and Stop conditions allows the determination of when the bus is free. Control of the I<sup>2</sup>C bus can be taken when the P bit is set in the SSP1STAT register, or the bus is Idle and the S and P bits are cleared.

**FIGURE 30-32: BUS COLLISION TIMING FOR TRANSMIT AND ACKNOWLEDGE**



## 30.6.13.1 Bus Collision During a Start Condition

During a Start condition, a bus collision occurs if:

- SDA or SCL are sampled low at the beginning of the Start condition (Figure 30-33).
- SCL is sampled low before SDA is asserted low (Figure 30-34).

During a Start condition, both the SDA and the SCL pins are monitored.

If the SDA pin is already low, or the SCL pin is already low, then all of the following occur:

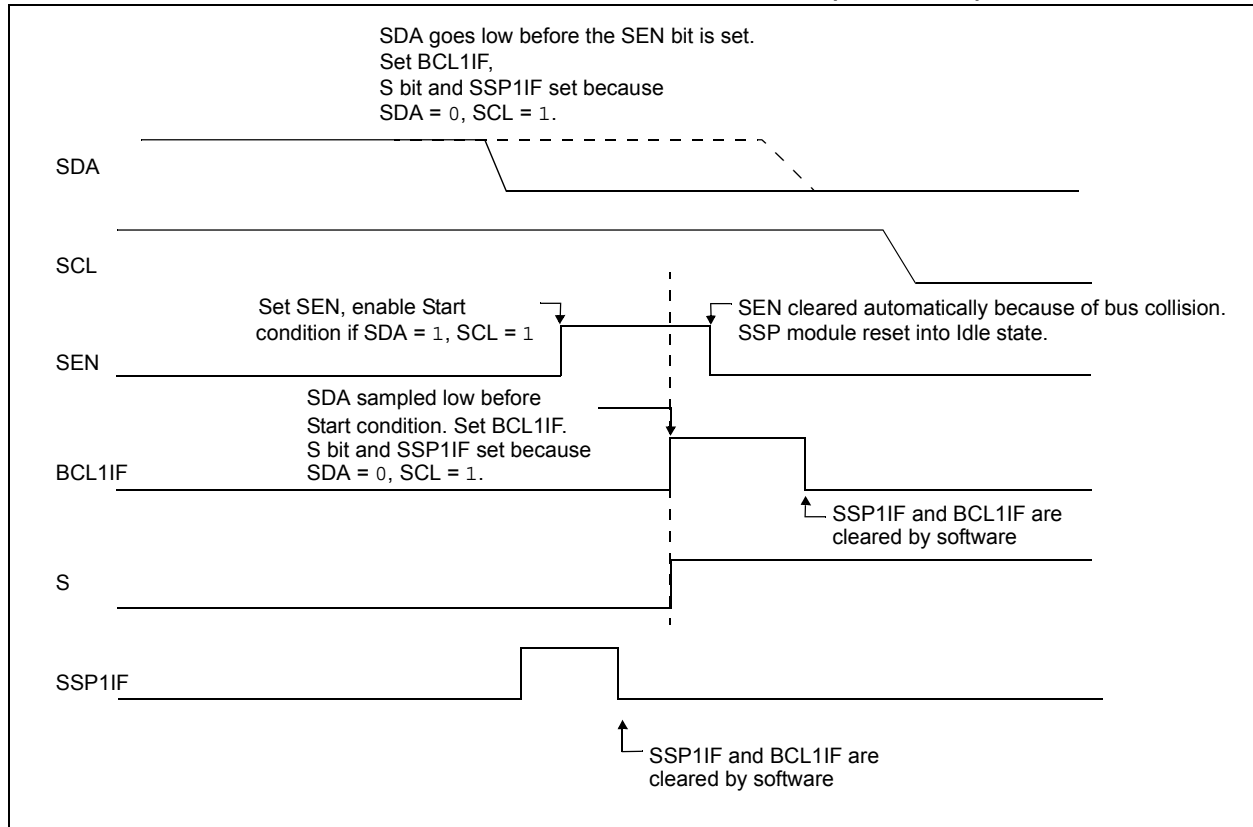
- the Start condition is aborted,
- the BCL1IF flag is set and
- the MSSP module is reset to its Idle state (Figure 30-33).

The Start condition begins with the SDA and SCL pins deasserted. When the SDA pin is sampled high, the Baud Rate Generator is loaded and counts down. If the SCL pin is sampled low while SDA is high, a bus collision occurs because it is assumed that another master is attempting to drive a data '1' during the Start condition.

If the SDA pin is sampled low during this count, the BRG is reset and the SDA line is asserted early (Figure 30-35). If, however, a '1' is sampled on the SDA pin, the SDA pin is asserted low at the end of the BRG count. The Baud Rate Generator is then reloaded and counts down to zero; if the SCL pin is sampled as '0' during this time, a bus collision does not occur. At the end of the BRG count, the SCL pin is asserted low.

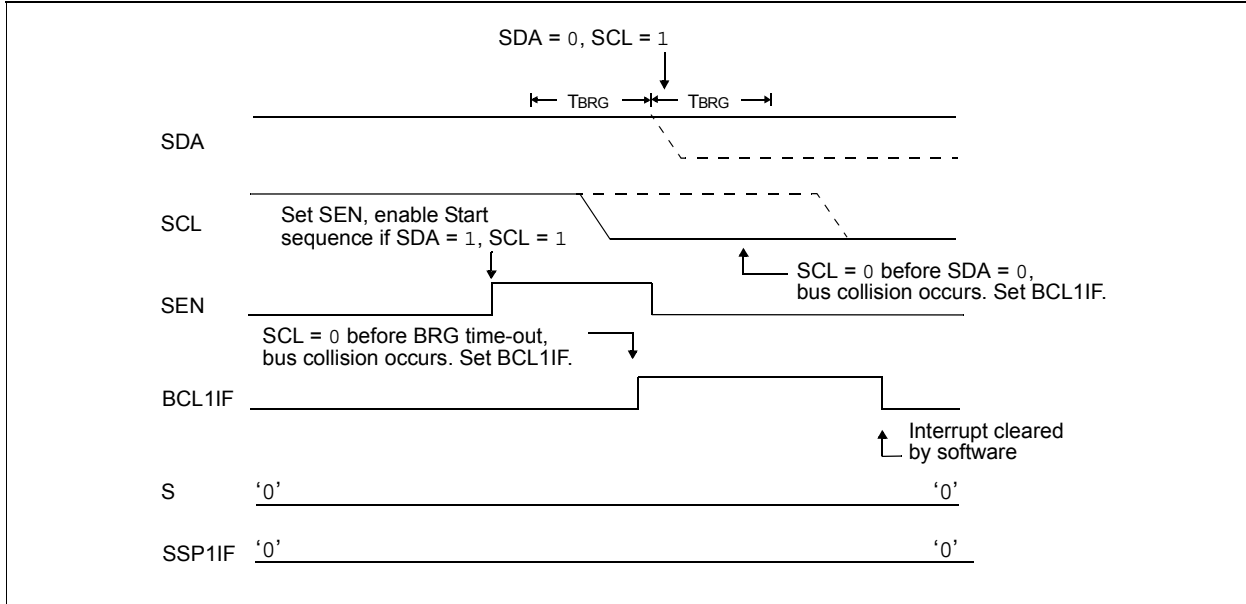
**Note:** The reason that bus collision is not a factor during a Start condition is that no two bus masters can assert a Start condition at the exact same time. Therefore, one master will always assert SDA before the other. This condition does not cause a bus collision because the two masters must be allowed to arbitrate the first address following the Start condition. If the address is the same, arbitration must be allowed to continue into the data portion, Repeated Start or Stop conditions.

**FIGURE 30-33: BUS COLLISION DURING START CONDITION (SDA ONLY)**

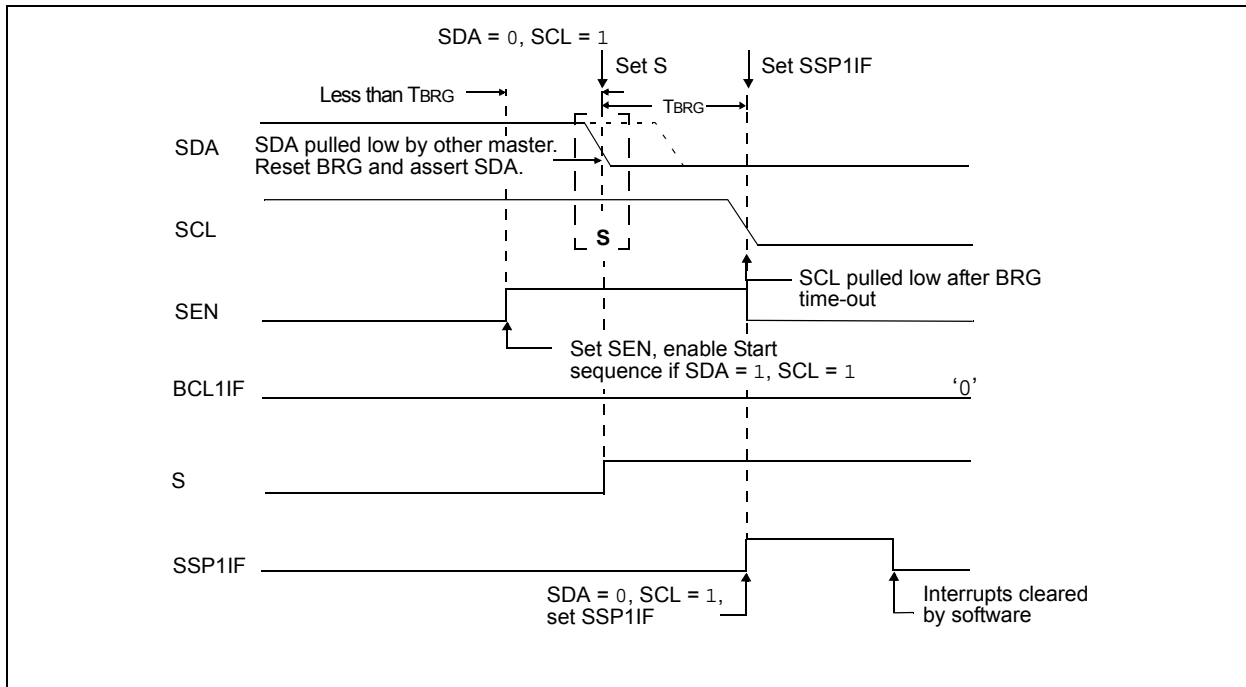


# PIC16(L)F1717/8/9

**FIGURE 30-34: BUS COLLISION DURING START CONDITION (SCL = 0)**



**FIGURE 30-35: BRG RESET DUE TO SDA ARBITRATION DURING START CONDITION**



## 30.6.13.2 Bus Collision During a Repeated Start Condition

During a Repeated Start condition, a bus collision occurs if:

- A low level is sampled on SDA when SCL goes from low level to high level (Case 1).
- SCL goes low before SDA is asserted low, indicating that another master is attempting to transmit a data '1' (Case 2).

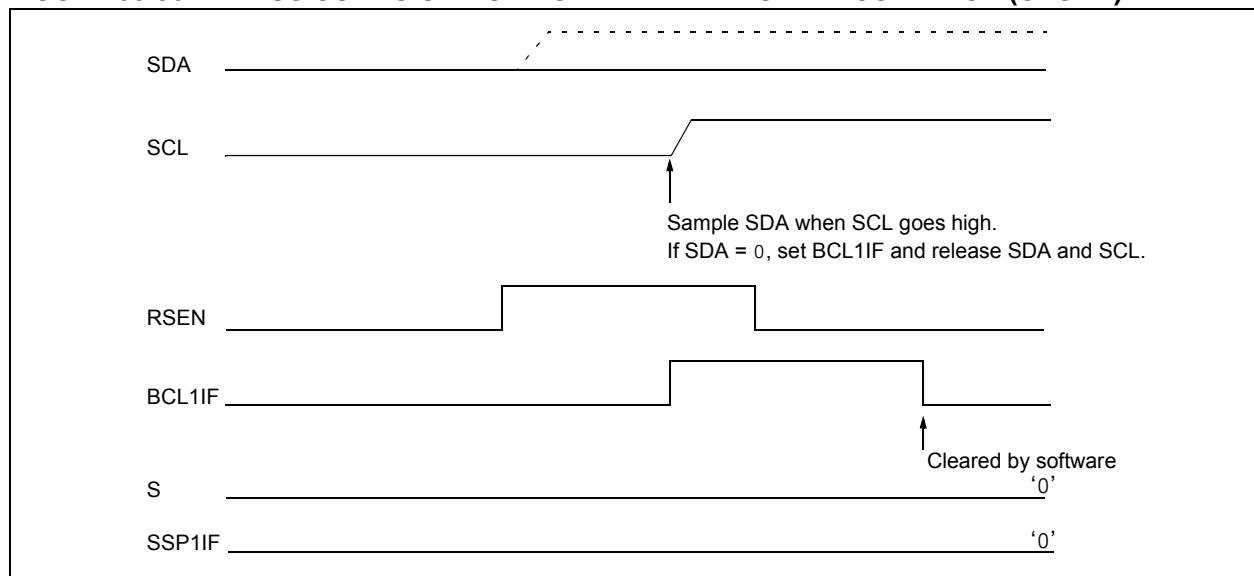
When the user releases SDA and the pin is allowed to float high, the BRG is loaded with SSP1ADD and counts down to zero. The SCL pin is then deasserted and when sampled high, the SDA pin is sampled.

If SDA is low, a bus collision has occurred (i.e., another master is attempting to transmit a data '0', [Figure 30-36](#)). If SDA is sampled high, the BRG is reloaded and begins counting. If SDA goes from high-to-low before the BRG times out, no bus collision occurs because no two masters can assert SDA at exactly the same time.

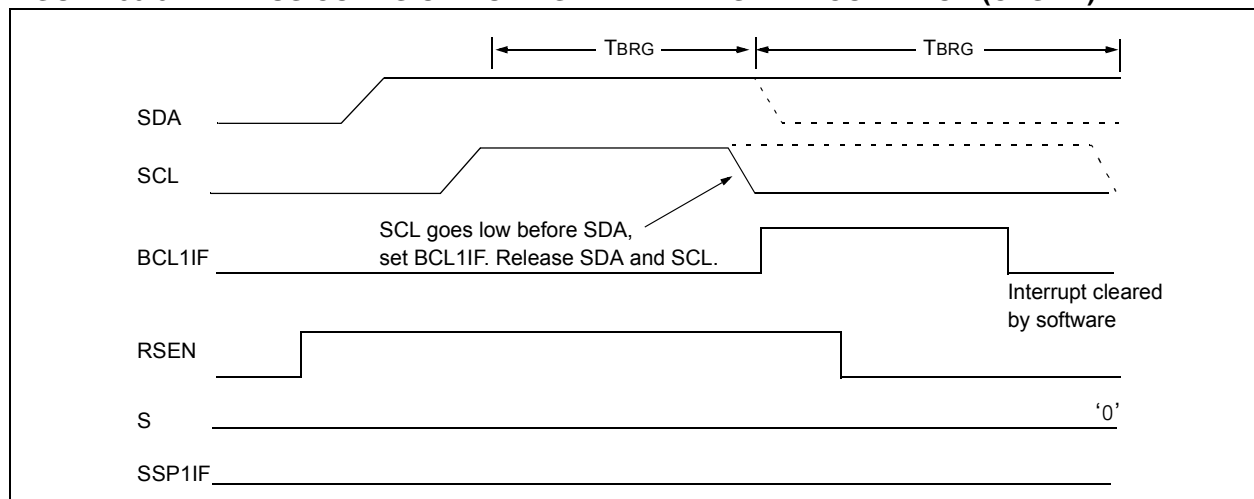
If SCL goes from high-to-low before the BRG times out and SDA has not already been asserted, a bus collision occurs. In this case, another master is attempting to transmit a data '1' during the Repeated Start condition, see [Figure 30-37](#).

If, at the end of the BRG time-out, both SCL and SDA are still high, the SDA pin is driven low and the BRG is reloaded and begins counting. At the end of the count, regardless of the status of the SCL pin, the SCL pin is driven low and the Repeated Start condition is complete.

**FIGURE 30-36: BUS COLLISION DURING A REPEATED START CONDITION (CASE 1)**



**FIGURE 30-37: BUS COLLISION DURING REPEATED START CONDITION (CASE 2)**



# PIC16(L)F1717/8/9

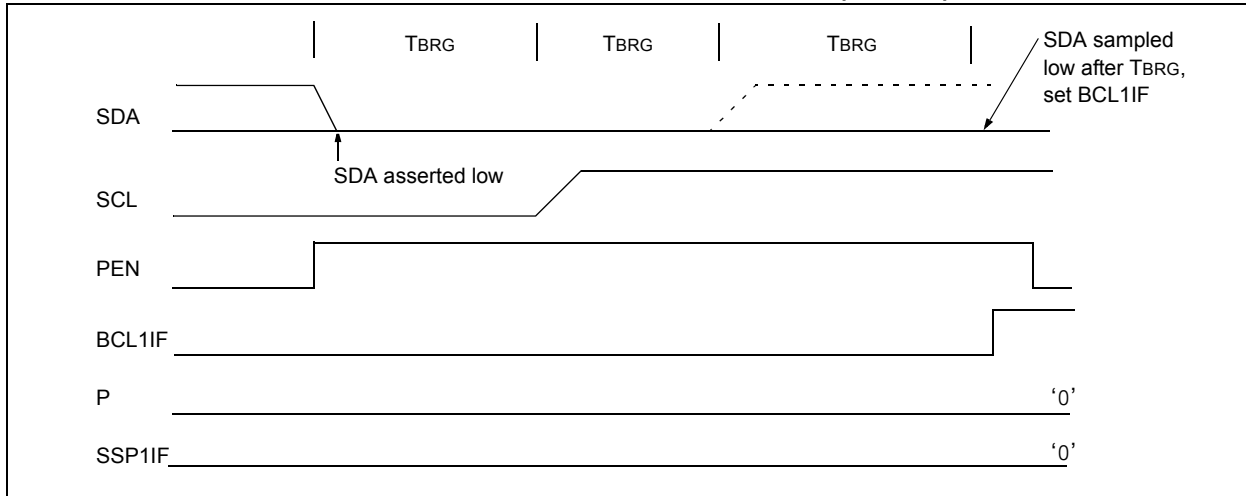
## 30.6.13.3 Bus Collision During a Stop Condition

Bus collision occurs during a Stop condition if:

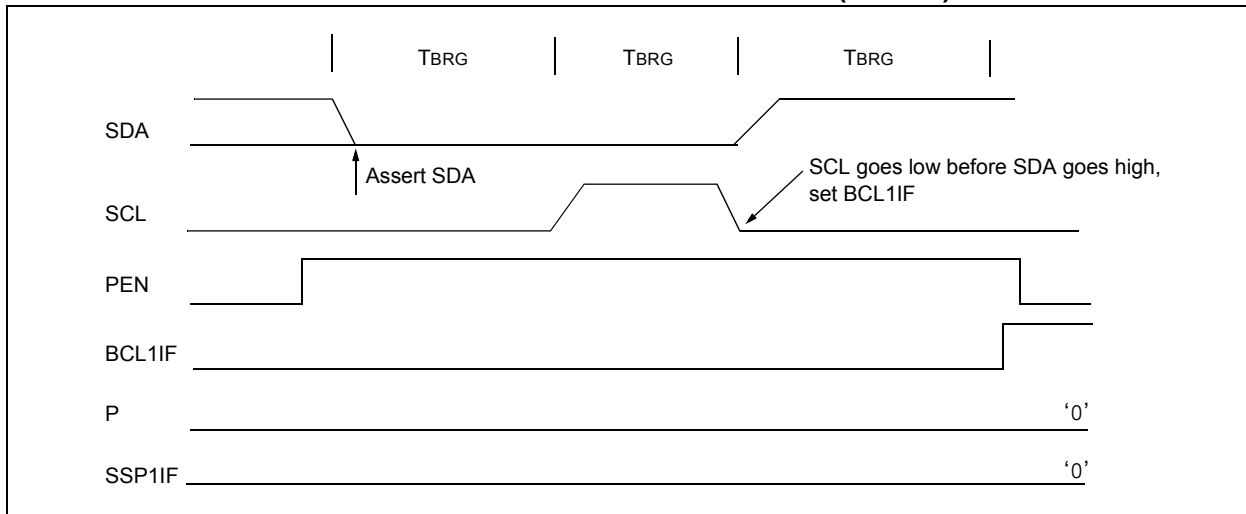
- a) After the SDA pin has been deasserted and allowed to float high, SDA is sampled low after the BRG has timed out (Case 1).
- b) After the SCL pin is deasserted, SCL is sampled low before SDA goes high (Case 2).

The Stop condition begins with SDA asserted low. When SDA is sampled low, the SCL pin is allowed to float. When the pin is sampled high (clock arbitration), the Baud Rate Generator is loaded with SSP1ADD and counts down to zero. After the BRG times out, SDA is sampled. If SDA is sampled low, a bus collision has occurred. This is due to another master attempting to drive a data '0' (Figure 30-38). If the SCL pin is sampled low before SDA is allowed to float high, a bus collision occurs. This is another case of another master attempting to drive a data '0' (Figure 30-39).

**FIGURE 30-38: BUS COLLISION DURING A STOP CONDITION (CASE 1)**



**FIGURE 30-39: BUS COLLISION DURING A STOP CONDITION (CASE 2)**



**TABLE 30-3: SUMMARY OF REGISTERS ASSOCIATED WITH I<sup>2</sup>C OPERATION**

Name	Bit 7	Bit 6	Bit 5	Bit 4	Bit 3	Bit 2	Bit 1	Bit 0	Reset Values on Page
ANSELB	—	—	ANSB5	ANSB4	ANSB3	ANSB2	ANSB1	ANSB0	131
ANSELC	ANSC7	ANSC6	ANSC5	ANSC4	ANSC3	ANSC2	—	—	136
INTCON	GIE	PEIE	TMR0IE	INTE	IOIE	TMR0IF	INTF	IOCF	90
PIE1	TMR1GIE	ADIE	RCIE	TXIE	SSP1IE	CCP1IE	TMR2IE	TMR1IE	91
PIE2	OSFIE	C2IE	C1IE	—	BCL1IE	TMR6IE	TMR4IE	CCP2IE	92
PIR1	TMR1GIF	ADIF	RCIF	TXIF	SSP1IF	CCP1IF	TMR2IF	TMR1IF	94
PIR2	OSFIF	C2IF	C1IF	—	BCL1IF	TMR6IF	TMR4IF	CCP2IF	95
RxyPPS	—	—	—	RxyPPS<4:0>					153
SSPCLKPPS	—	—	—	SSPCLKPPS<4:0>					152
SSPDATPPS	—	—	—	SSPDATPPS<4:0>					152
SSP1ADD	ADD<7:0>								350
SSP1BUF	Synchronous Serial Port Receive Buffer/Transmit Register								299*
SSP1CON1	WCOL	SSPOV	SSPEN	CKP	SSPM<3:0>				346
SSP1CON2	GCEN	ACKSTAT	ACKDT	ACKEN	RCEN	PEN	RSEN	SEN	348
SSP1CON3	ACKTIM	PCIE	SCIE	BOEN	SDAHT	SBCDE	AHEN	DHEN	349
SSP1MSK	MSK<7:0>								350
SSP1STAT	SMP	CKE	D/A	P	S	R/W	UA	BF	345
TRISB	TRISB7	TRISB6	TRISB5	TRISB4	TRISB3	TRISB2	TRISB1	TRISB0	130
TRISC	TRISC7	TRISC6	TRISC5	TRISC4	TRISC3	TRISC2	TRISC1	TRISC0	135

**Legend:** — = unimplemented location, read as '0'. Shaded cells are not used by the MSSP module in I<sup>2</sup>C mode.

\* Page provides register information.

# PIC16(L)F1717/8/9

## 30.7 BAUD RATE GENERATOR

The MSSP module has a Baud Rate Generator available for clock generation in both I<sup>2</sup>C and SPI Master modes. The Baud Rate Generator (BRG) reload value is placed in the SSP1ADD register (Register 30-6). When a write occurs to SSP1BUF, the Baud Rate Generator will automatically begin counting down.

Once the given operation is complete, the internal clock will automatically stop counting and the clock pin will remain in its last state.

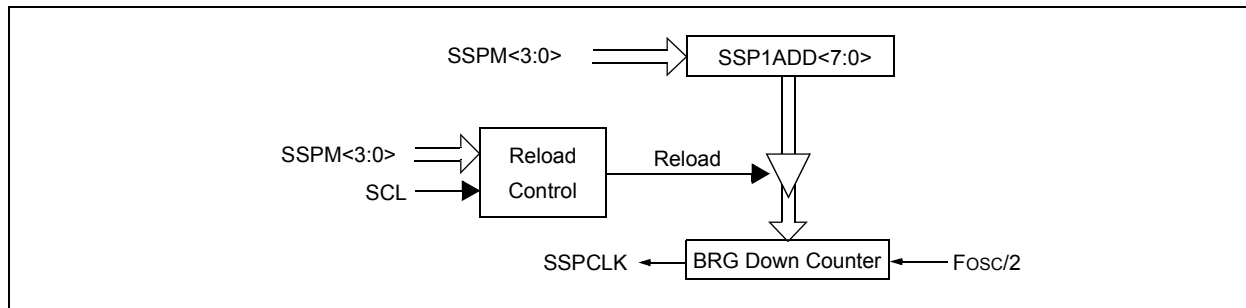
An internal signal “Reload” in Figure 30-40 triggers the value from SSP1ADD to be loaded into the BRG counter. This occurs twice for each oscillation of the module clock line. The logic dictating when the reload signal is asserted depends on the mode the MSSP is being operated in.

Table 30-4 demonstrates clock rates based on instruction cycles and the BRG value loaded into SSP1ADD.

### EQUATION 30-1:

$$F_{CLOCK} = \frac{F_{OSC}}{(SSPxADD + 1)(4)}$$

**FIGURE 30-40: BAUD RATE GENERATOR BLOCK DIAGRAM**



**Note:** Values of 0x00, 0x01 and 0x02 are not valid for SSP1ADD when used as a Baud Rate Generator for I<sup>2</sup>C. This is an implementation limitation.

**TABLE 30-4: MSSP CLOCK RATE W/BRG**

Fosc	Fcy	BRG Value	F <sub>CLOCK</sub> (2 Rollovers of BRG)
32 MHz	8 MHz	13h	400 kHz
32 MHz	8 MHz	19h	308 kHz
32 MHz	8 MHz	4Fh	100 kHz
16 MHz	4 MHz	09h	400 kHz
16 MHz	4 MHz	0Ch	308 kHz
16 MHz	4 MHz	27h	100 kHz
4 MHz	1 MHz	09h	100 kHz

**Note:** Refer to the I/O port electrical and timing specifications in Table 34-10 and Figure 34-7 to ensure the system is designed to support IOL requirements.



## 30.8 Register Definitions: MSSP Control

### REGISTER 30-1: SSP1STAT: SSP STATUS REGISTER

R/W-0/0	R/W-0/0	R-0/0	R-0/0	R-0/0	R-0/0	R-0/0	R-0/0
SMP	CKE	D/A	P	S	R/W	UA	BF
bit 7							bit 0

#### Legend:

R = Readable bit	W = Writable bit	U = Unimplemented bit, read as '0'
u = Bit is unchanged	x = Bit is unknown	-n/n = Value at POR and BOR/Value at all other Resets
'1' = Bit is set	'0' = Bit is cleared	

bit 7	<p><b>SMP:</b> SPI Data Input Sample bit</p> <p><u>SPI Master mode:</u></p> <p>1 = Input data sampled at end of data output time</p> <p>0 = Input data sampled at middle of data output time</p> <p><u>SPI Slave mode:</u></p> <p>SMP must be cleared when SPI is used in Slave mode</p> <p><u>In I<sup>2</sup>C Master or Slave mode:</u></p> <p>1 = Slew rate control disabled for Standard Speed mode (100 kHz and 1 MHz)</p> <p>0 = Slew rate control enabled for High-Speed mode (400 kHz)</p>
bit 6	<p><b>CKE:</b> SPI Clock Edge Select bit (SPI mode only)</p> <p><u>In SPI Master or Slave mode:</u></p> <p>1 = Transmit occurs on transition from active to Idle clock state</p> <p>0 = Transmit occurs on transition from Idle to active clock state</p> <p><u>In I<sup>2</sup>C™ mode only:</u></p> <p>1 = Enable input logic so that thresholds are compliant with SMBus specification</p> <p>0 = Disable SMBus specific inputs</p>
bit 5	<p><b>D/A:</b> Data/Address bit (I<sup>2</sup>C mode only)</p> <p>1 = Indicates that the last byte received or transmitted was data</p> <p>0 = Indicates that the last byte received or transmitted was address</p>
bit 4	<p><b>P:</b> Stop bit</p> <p>(I<sup>2</sup>C mode only. This bit is cleared when the MSSP module is disabled, SSPEN is cleared.)</p> <p>1 = Indicates that a Stop bit has been detected last (this bit is '0' on Reset)</p> <p>0 = Stop bit was not detected last</p>
bit 3	<p><b>S:</b> Start bit</p> <p>(I<sup>2</sup>C mode only. This bit is cleared when the MSSP module is disabled, SSPEN is cleared.)</p> <p>1 = Indicates that a Start bit has been detected last (this bit is '0' on Reset)</p> <p>0 = Start bit was not detected last</p>
bit 2	<p><b>R/W:</b> Read/Write bit information (I<sup>2</sup>C mode only)</p> <p>This bit holds the R/W bit information following the last address match. This bit is only valid from the address match to the next Start bit, Stop bit, or not ACK bit.</p> <p><u>In I<sup>2</sup>C Slave mode:</u></p> <p>1 = Read</p> <p>0 = Write</p> <p><u>In I<sup>2</sup>C Master mode:</u></p> <p>1 = Transmit is in progress</p> <p>0 = Transmit is not in progress</p> <p>OR-ing this bit with SEN, RSEN, PEN, RCEN or ACKEN will indicate if the MSSP is in Idle mode.</p>
bit 1	<p><b>UA:</b> Update Address bit (10-bit I<sup>2</sup>C mode only)</p> <p>1 = Indicates that the user needs to update the address in the SSP1ADD register</p> <p>0 = Address does not need to be updated</p>
bit 0	<p><b>BF:</b> Buffer Full Status bit</p> <p><u>Receive (SPI and I<sup>2</sup>C modes):</u></p> <p>1 = Receive complete, SSP1BUF is full</p> <p>0 = Receive not complete, SSP1BUF is empty</p> <p><u>Transmit (I<sup>2</sup>C mode only):</u></p> <p>1 = Data transmit in progress (does not include the ACK and Stop bits), SSP1BUF is full</p> <p>0 = Data transmit complete (does not include the ACK and Stop bits), SSP1BUF is empty</p>

# PIC16(L)F1717/8/9

## REGISTER 30-2: SSP1CON1: SSP CONTROL REGISTER 1

R/C/HS-0/0	R/C/HS-0/0	R/W-0/0	R/W-0/0	R/W-0/0	R/W-0/0	R/W-0/0	R/W-0/0
WCOL	SSPOV <sup>(1)</sup>	SSPEN	CKP	SSPM<3:0>			
bit 7							bit 0

### Legend:

R = Readable bit	W = Writable bit	U = Unimplemented bit, read as '0'
u = Bit is unchanged	x = Bit is unknown	-n/n = Value at POR and BOR/Value at all other Resets
'1' = Bit is set	'0' = Bit is cleared	HS = Bit is set by hardware      C = User cleared

bit 7	<p><b>WCOL:</b> Write Collision Detect bit</p> <p><u>Master mode:</u></p> <p>1 = A write to the SSP1BUF register was attempted while the I<sup>2</sup>C conditions were not valid for a transmission to be started</p> <p>0 = No collision</p> <p><u>Slave mode:</u></p> <p>1 = The SSP1BUF register is written while it is still transmitting the previous word (must be cleared in software)</p> <p>0 = No collision</p>
bit 6	<p><b>SSPOV:</b> Receive Overflow Indicator bit<sup>(1)</sup></p> <p><u>In SPI mode:</u></p> <p>1 = A new byte is received while the SSP1BUF register is still holding the previous data. In case of overflow, the data in SSP1SR is lost. Overflow can only occur in Slave mode. In Slave mode, the user must read the SSP1BUF, even if only transmitting data, to avoid setting overflow. In Master mode, the overflow bit is not set since each new reception (and transmission) is initiated by writing to the SSP1BUF register (must be cleared in software).</p> <p>0 = No overflow</p> <p><u>In I<sup>2</sup>C mode:</u></p> <p>1 = A byte is received while the SSP1BUF register is still holding the previous byte. SSPOV is a "don't care" in Transmit mode (must be cleared in software).</p> <p>0 = No overflow</p>
bit 5	<p><b>SSPEN:</b> Synchronous Serial Port Enable bit</p> <p>In both modes, when enabled, these pins must be properly configured as input or output</p> <p><u>In SPI mode:</u></p> <p>1 = Enables serial port and configures SCK, SDO, SDI and <math>\overline{SS}</math> as the source of the serial port pins<sup>(2)</sup></p> <p>0 = Disables serial port and configures these pins as I/O port pins</p> <p><u>In I<sup>2</sup>C mode:</u></p> <p>1 = Enables the serial port and configures the SDA and SCL pins as the source of the serial port pins<sup>(3)</sup></p> <p>0 = Disables serial port and configures these pins as I/O port pins</p>
bit 4	<p><b>CKP:</b> Clock Polarity Select bit</p> <p><u>In SPI mode:</u></p> <p>1 = Idle state for clock is a high level</p> <p>0 = Idle state for clock is a low level</p> <p><u>In I<sup>2</sup>C Slave mode:</u></p> <p>SCL release control</p> <p>1 = Enable clock</p> <p>0 = Holds clock low (clock stretch). (Used to ensure data setup time.)</p> <p><u>In I<sup>2</sup>C Master mode:</u></p> <p>Unused in this mode</p>
bit 3-0	<p><b>SSPM&lt;3:0&gt;:</b> Synchronous Serial Port Mode Select bits</p> <p>1111 = I<sup>2</sup>C Slave mode, 10-bit address with Start and Stop bit interrupts enabled</p> <p>1110 = I<sup>2</sup>C Slave mode, 7-bit address with Start and Stop bit interrupts enabled</p> <p>1101 = Reserved</p> <p>1100 = Reserved</p> <p>1011 = I<sup>2</sup>C firmware controlled Master mode (slave idle)</p> <p>1010 = SPI Master mode, clock = <math>F_{osc}/(4 * (SSP1ADD+1))</math><sup>(5)</sup></p> <p>1001 = Reserved</p> <p>1000 = I<sup>2</sup>C Master mode, clock = <math>F_{osc} / (4 * (SSP1ADD+1))</math><sup>(4)</sup></p> <p>0111 = I<sup>2</sup>C Slave mode, 10-bit address</p> <p>0110 = I<sup>2</sup>C Slave mode, 7-bit address</p> <p>0101 = SPI Slave mode, clock = SCK pin, <math>\overline{SS}</math> pin control disabled, <math>\overline{SS}</math> can be used as I/O pin</p> <p>0100 = SPI Slave mode, clock = SCK pin, <math>\overline{SS}</math> pin control enabled</p> <p>0011 = SPI Master mode, clock = T2_match/2</p> <p>0010 = SPI Master mode, clock = <math>F_{osc}/64</math></p> <p>0001 = SPI Master mode, clock = <math>F_{osc}/16</math></p> <p>0000 = SPI Master mode, clock = <math>F_{osc}/4</math></p>

## REGISTER 30-2: SSP1CON1: SSP CONTROL REGISTER 1 (CONTINUED)

- Note**
- 1: In Master mode, the overflow bit is not set since each new reception (and transmission) is initiated by writing to the SSP1BUF register.
  - 2: When enabled, these pins must be properly configured as input or output. Use SSPSSPPS, SSPCLKPPS, SSPDATPPS, and RxyPPS to select the pins.
  - 3: When enabled, the SDA and SCL pins must be configured as inputs. Use SSPCLKPPS, SSPDATPPS, and RxyPPS to select the pins.
  - 4: SSP1ADD values of 0, 1 or 2 are not supported for I<sup>2</sup>C mode.
  - 5: SSP1ADD value of '0' is not supported. Use SSPM = 0000 instead.

# PIC16(L)F1717/8/9

## REGISTER 30-3: SSP1CON2: SSP CONTROL REGISTER 2<sup>(1)</sup>

R/W-0/0	R-0/0	R/W-0/0	R/S/HS-0/0	R/S/HS-0/0	R/S/HS-0/0	R/S/HS-0/0	R/W/HS-0/0
GCEN	ACKSTAT	ACKDT	ACKEN	RCEN	PEN	RSEN	SEN
bit 7							bit 0

### Legend:

R = Readable bit	W = Writable bit	U = Unimplemented bit, read as '0'
u = Bit is unchanged	x = Bit is unknown	-n/n = Value at POR and BOR/Value at all other Resets
'1' = Bit is set	'0' = Bit is cleared	HC = Cleared by hardware S = User set

- bit 7      **GCEN:** General Call Enable bit (in I<sup>2</sup>C Slave mode only)  
1 = Enable interrupt when a general call address (0x00 or 00h) is received in the SSP1SR  
0 = General call address disabled
- bit 6      **ACKSTAT:** Acknowledge Status bit (in I<sup>2</sup>C mode only)  
1 = Acknowledge was not received  
0 = Acknowledge was received
- bit 5      **ACKDT:** Acknowledge Data bit (in I<sup>2</sup>C mode only)  
In Receive mode:  
Value transmitted when the user initiates an Acknowledge sequence at the end of a receive  
1 = Not Acknowledge  
0 = Acknowledge
- bit 4      **ACKEN:** Acknowledge Sequence Enable bit (in I<sup>2</sup>C Master mode only)  
In Master Receive mode:  
1 = Initiate Acknowledge sequence on SDA and SCL pins, and transmit ACKDT data bit.  
Automatically cleared by hardware.  
0 = Acknowledge sequence idle
- bit 3      **RCEN:** Receive Enable bit (in I<sup>2</sup>C Master mode only)  
1 = Enables Receive mode for I<sup>2</sup>C  
0 = Receive idle
- bit 2      **PEN:** Stop Condition Enable bit (in I<sup>2</sup>C Master mode only)  
SCKMSSP Release Control:  
1 = Initiate Stop condition on SDA and SCL pins. Automatically cleared by hardware.  
0 = Stop condition Idle
- bit 1      **RSEN:** Repeated Start Condition Enable bit (in I<sup>2</sup>C Master mode only)  
1 = Initiate Repeated Start condition on SDA and SCL pins. Automatically cleared by hardware.  
0 = Repeated Start condition Idle
- bit 0      **SEN:** Start Condition Enable/Stretch Enable bit  
In Master mode:  
1 = Initiate Start condition on SDA and SCL pins. Automatically cleared by hardware.  
0 = Start condition Idle  
In Slave mode:  
1 = Clock stretching is enabled for both slave transmit and slave receive (stretch enabled)  
0 = Clock stretching is disabled

**Note 1:** For bits ACKEN, RCEN, PEN, RSEN, SEN: If the I<sup>2</sup>C module is not in the Idle mode, this bit may not be set (no spooling) and the SSP1BUF may not be written (or writes to the SSP1BUF are disabled).

## REGISTER 30-4: SSP1CON3: SSP CONTROL REGISTER 3

R-0/0	R/W-0/0	R/W-0/0	R/W-0/0	R/W-0/0	R/W-0/0	R/W-0/0	R/W-0/0
ACKTIM <sup>(3)</sup>	PCIE	SCIE	BOEN	SDAHT	SBCDE	AHEN	DHEN
bit 7							bit 0

### Legend:

R = Readable bit	W = Writable bit	U = Unimplemented bit, read as '0'
u = Bit is unchanged	x = Bit is unknown	-n/n = Value at POR and BOR/Value at all other Resets
'1' = Bit is set	'0' = Bit is cleared	

- bit 7      **ACKTIM:** Acknowledge Time Status bit (I<sup>2</sup>C mode only)<sup>(3)</sup>  
 1 = Indicates the I<sup>2</sup>C bus is in an Acknowledge sequence, set on eighth falling edge of SCL clock  
 0 = Not an Acknowledge sequence, cleared on 9<sup>TH</sup> rising edge of SCL clock
- bit 6      **PCIE:** Stop Condition Interrupt Enable bit (I<sup>2</sup>C Slave mode only)  
 1 = Enable interrupt on detection of Stop condition  
 0 = Stop detection interrupts are disabled<sup>(2)</sup>
- bit 5      **SCIE:** Start Condition Interrupt Enable bit (I<sup>2</sup>C Slave mode only)  
 1 = Enable interrupt on detection of Start or Restart conditions  
 0 = Start detection interrupts are disabled<sup>(2)</sup>
- bit 4      **BOEN:** Buffer Overwrite Enable bit  
In SPI Slave mode:<sup>(1)</sup>  
     1 = SSP1BUF updates every time that a new data byte is shifted in ignoring the BF bit  
     0 = If new byte is received with BF bit of the SSP1STAT register already set, SSPOV bit of the SSP1CON1 register is set, and the buffer is not updated  
In I<sup>2</sup>C Master mode and SPI Master mode:  
     This bit is ignored.  
In I<sup>2</sup>C Slave mode:  
     1 = SSP1BUF is updated and  $\overline{ACK}$  is generated for a received address/data byte, ignoring the state of the SSPOV bit only if the BF bit = 0.  
     0 = SSP1BUF is only updated when SSPOV is clear
- bit 3      **SDAHT:** SDA Hold Time Selection bit (I<sup>2</sup>C mode only)  
 1 = Minimum of 300 ns hold time on SDA after the falling edge of SCL  
 0 = Minimum of 100 ns hold time on SDA after the falling edge of SCL
- bit 2      **SBCDE:** Slave Mode Bus Collision Detect Enable bit (I<sup>2</sup>C Slave mode only)  
 If, on the rising edge of SCL, SDA is sampled low when the module is outputting a high state, the BCL1IF bit of the PIR2 register is set, and bus goes idle  
 1 = Enable slave bus collision interrupts  
 0 = Slave bus collision interrupts are disabled
- bit 1      **AHEN:** Address Hold Enable bit (I<sup>2</sup>C Slave mode only)  
 1 = Following the eighth falling edge of SCL for a matching received address byte; CKP bit of the SSP1CON1 register will be cleared and the SCL will be held low.  
 0 = Address holding is disabled
- bit 0      **DHEN:** Data Hold Enable bit (I<sup>2</sup>C Slave mode only)  
 1 = Following the eighth falling edge of SCL for a received data byte; slave hardware clears the CKP bit of the SSP1CON1 register and SCL is held low.  
 0 = Data holding is disabled

- Note 1:** For daisy-chained SPI operation; allows the user to ignore all but the last received byte. SSPOV is still set when a new byte is received and BF = 1, but hardware continues to write the most recent byte to SSP1BUF.
- 2:** This bit has no effect in Slave modes that Start and Stop condition detection is explicitly listed as enabled.
- 3:** The ACKTIM Status bit is only active when the AHEN bit or DHEN bit is set.

# PIC16(L)F1717/8/9

## REGISTER 30-5: SSP1MSK: SSP MASK REGISTER

R/W-1/1	R/W-1/1	R/W-1/1	R/W-1/1	R/W-1/1	R/W-1/1	R/W-1/1	R/W-1/1
MSK<7:0>							
bit 7							bit 0

### Legend:

R = Readable bit	W = Writable bit	U = Unimplemented bit, read as '0'
u = Bit is unchanged	x = Bit is unknown	-n/n = Value at POR and BOR/Value at all other Resets
'1' = Bit is set	'0' = Bit is cleared	

bit 7-1 **MSK<7:1>**: Mask bits

- 1 = The received address bit n is compared to SSP1ADD<n> to detect I<sup>2</sup>C address match
- 0 = The received address bit n is not used to detect I<sup>2</sup>C address match

bit 0 **MSK<0>**: Mask bit for I<sup>2</sup>C Slave mode, 10-bit Address

I<sup>2</sup>C Slave mode, 10-bit address (SSPM<3:0> = 0111 or 1111):

- 1 = The received address bit 0 is compared to SSP1ADD<0> to detect I<sup>2</sup>C address match
- 0 = The received address bit 0 is not used to detect I<sup>2</sup>C address match

I<sup>2</sup>C Slave mode, 7-bit address, the bit is ignored

## REGISTER 30-6: SSP1ADD: MSSP ADDRESS AND BAUD RATE REGISTER (I<sup>2</sup>C MODE)

R/W-0/0	R/W-0/0	R/W-0/0	R/W-0/0	R/W-0/0	R/W-0/0	R/W-0/0	R/W-0/0
ADD<7:0>							
bit 7							bit 0

### Legend:

R = Readable bit	W = Writable bit	U = Unimplemented bit, read as '0'
u = Bit is unchanged	x = Bit is unknown	-n/n = Value at POR and BOR/Value at all other Resets
'1' = Bit is set	'0' = Bit is cleared	

### Master mode:

bit 7-0 **ADD<7:0>**: Baud Rate Clock Divider bits  
SCL pin clock period = ((ADD<7:0> + 1) \* 4) / Fosc

### 10-Bit Slave mode – Most Significant Address Byte:

bit 7-3 **Not used**: Unused for Most Significant Address Byte. Bit state of this register is a “don't care”. Bit pattern sent by master is fixed by I<sup>2</sup>C specification and must be equal to '11110'. However, those bits are compared by hardware and are not affected by the value in this register.

bit 2-1 **ADD<2:1>**: Two Most Significant bits of 10-bit address

bit 0 **Not used**: Unused in this mode. Bit state is a “don't care”.

### 10-Bit Slave mode – Least Significant Address Byte:

bit 7-0 **ADD<7:0>**: Eight Least Significant bits of 10-bit address

### 7-Bit Slave mode:

bit 7-1 **ADD<7:1>**: 7-bit address

bit 0 **Not used**: Unused in this mode. Bit state is a “don't care”.

## 31.0 ENHANCED UNIVERSAL SYNCHRONOUS ASYNCHRONOUS RECEIVER TRANSMITTER (EUSART)

The Enhanced Universal Synchronous Asynchronous Receiver Transmitter (EUSART) module is a serial I/O communications peripheral. It contains all the clock generators, shift registers and data buffers necessary to perform an input or output serial data transfer independent of device program execution. The EUSART, also known as a Serial Communications Interface (SCI), can be configured as a full-duplex asynchronous system or half-duplex synchronous system. Full-Duplex mode is useful for communications with peripheral systems, such as CRT terminals and personal computers. Half-Duplex Synchronous mode is intended for communications with peripheral devices, such as A/D or D/A integrated circuits, serial EEPROMs or other microcontrollers. These devices typically do not have internal clocks for baud rate generation and require the external clock signal provided by a master synchronous device.

The EUSART module includes the following capabilities:

- Full-duplex asynchronous transmit and receive
- Two-character input buffer
- One-character output buffer
- Programmable 8-bit or 9-bit character length
- Address detection in 9-bit mode
- Input buffer overrun error detection
- Received character framing error detection
- Half-duplex synchronous master
- Half-duplex synchronous slave
- Programmable clock polarity in synchronous modes
- Sleep operation

The EUSART module implements the following additional features, making it ideally suited for use in Local Interconnect Network (LIN) bus systems:

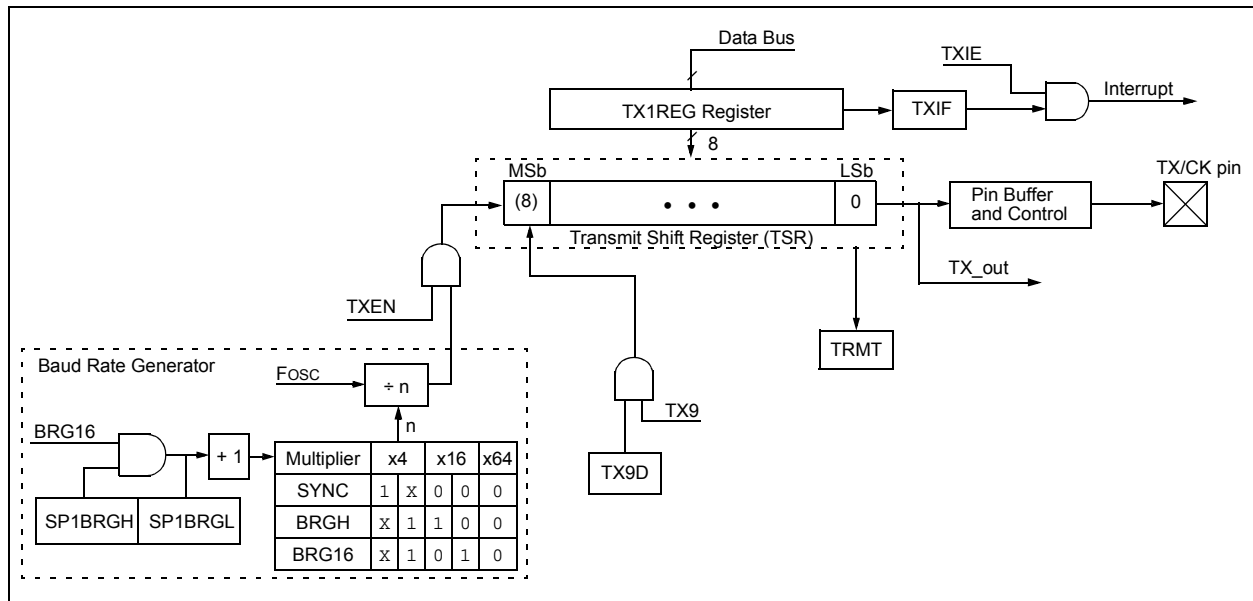
- Automatic detection and calibration of the baud rate
- Wake-up on Break reception
- 13-bit Break character transmit

Block diagrams of the EUSART transmitter and receiver are shown in [Figure 31-1](#) and [Figure 31-2](#).

The EUSART transmit output (TX\_out) is available to the TX/CK pin and internally to the following peripherals:

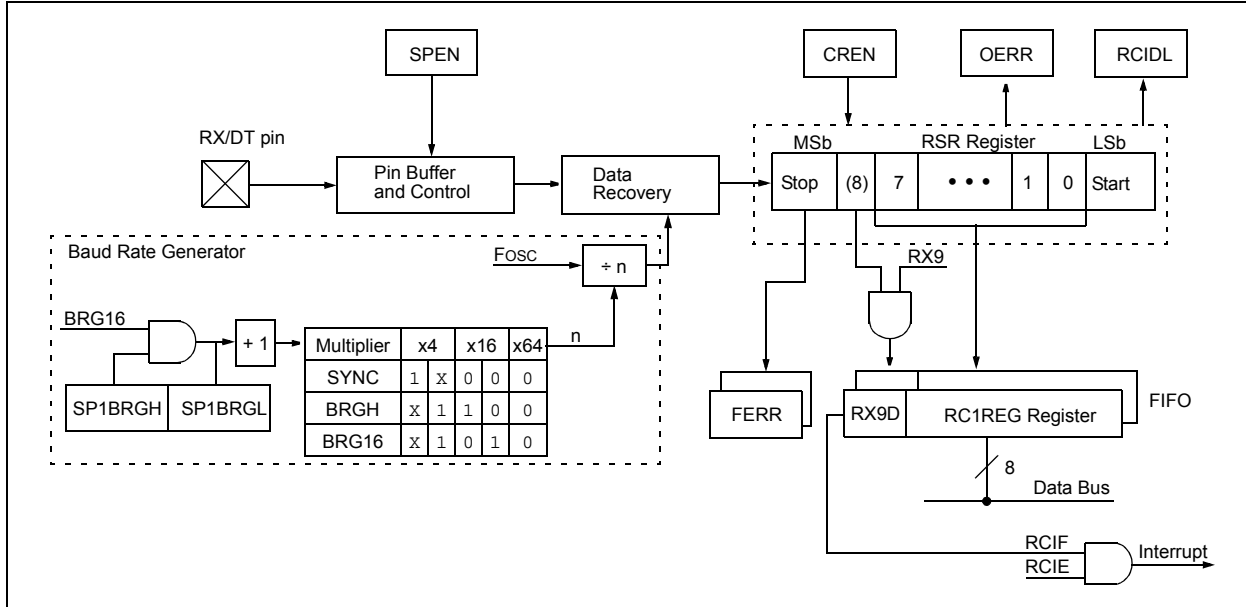
- Configurable Logic Cell (CLC)

**FIGURE 31-1: EUSART TRANSMIT BLOCK DIAGRAM**



# PIC16(L)F1717/8/9

**FIGURE 31-2: EUSART RECEIVE BLOCK DIAGRAM**



The operation of the EUSART module is controlled through three registers:

- Transmit Status and Control (TX1STA)
- Receive Status and Control (RC1STA)
- Baud Rate Control (BAUD1CON)

These registers are detailed in [Register 31-1](#), [Register 31-2](#) and [Register 31-3](#), respectively.

The RX and CK input pins are selected with the RXPPS and CKPPS registers, respectively. TX, CK, and DT output pins are selected with each pin's RxyPPS register. Since the RX input is coupled with the DT output in Synchronous mode, it is the user's responsibility to select the same pin for both of these functions when operating in Synchronous mode. The EUSART control logic will control the data direction drivers automatically.



## 31.1 EUSART Asynchronous Mode

The EUSART transmits and receives data using the standard non-return-to-zero (NRZ) format. NRZ is implemented with two levels: a V<sub>OH</sub> Mark state which represents a '1' data bit, and a V<sub>OL</sub> Space state which represents a '0' data bit. NRZ refers to the fact that consecutively transmitted data bits of the same value stay at the output level of that bit without returning to a neutral level between each bit transmission. An NRZ transmission port idles in the Mark state. Each character transmission consists of one Start bit followed by eight or nine data bits and is always terminated by one or more Stop bits. The Start bit is always a space and the Stop bits are always marks. The most common data format is eight bits. Each transmitted bit persists for a period of 1/(Baud Rate). An on-chip dedicated 8-bit/16-bit Baud Rate Generator is used to derive standard baud rate frequencies from the system oscillator. See [Table 31-5](#) for examples of baud rate configurations.

The EUSART transmits and receives the LSb first. The EUSART's transmitter and receiver are functionally independent, but share the same data format and baud rate. Parity is not supported by the hardware, but can be implemented in software and stored as the ninth data bit.

### 31.1.1 EUSART ASYNCHRONOUS TRANSMITTER

The EUSART transmitter block diagram is shown in [Figure 31-1](#). The heart of the transmitter is the serial Transmit Shift Register (TSR), which is not directly accessible by software. The TSR obtains its data from the transmit buffer, which is the TX1REG register.

#### 31.1.1.1 Enabling the Transmitter

The EUSART transmitter is enabled for asynchronous operations by configuring the following three control bits:

- TXEN = 1
- SYNC = 0
- SPEN = 1

All other EUSART control bits are assumed to be in their default state.

Setting the TXEN bit of the TX1STA register enables the transmitter circuitry of the EUSART. Clearing the SYNC bit of the TX1STA register configures the EUSART for asynchronous operation. Setting the SPEN bit of the RC1STA register enables the EUSART and automatically configures the TX/CK I/O pin as an output. If the TX/CK pin is shared with an analog peripheral, the analog I/O function must be disabled by clearing the corresponding ANSEL bit.

**Note:** The TXIF Transmitter Interrupt flag is set when the TXEN enable bit is set.

#### 31.1.1.2 Transmitting Data

A transmission is initiated by writing a character to the TX1REG register. If this is the first character, or the previous character has been completely flushed from the TSR, the data in the TX1REG is immediately transferred to the TSR register. If the TSR still contains all or part of a previous character, the new character data is held in the TX1REG until the Stop bit of the previous character has been transmitted. The pending character in the TX1REG is then transferred to the TSR in one T<sub>cy</sub> immediately following the Stop bit transmission. The transmission of the Start bit, data bits and Stop bit sequence commences immediately following the transfer of the data to the TSR from the TX1REG.

#### 31.1.1.3 Transmit Data Polarity

The polarity of the transmit data can be controlled with the SCKP bit of the BAUD1CON register. The default state of this bit is '0' which selects high true transmit idle and data bits. Setting the SCKP bit to '1' will invert the transmit data resulting in low true idle and data bits. The SCKP bit controls transmit data polarity in Asynchronous mode only. In Synchronous mode, the SCKP bit has a different function. See [Section 31.5.1.2 "Clock Polarity"](#).

#### 31.1.1.4 Transmit Interrupt Flag

The TXIF interrupt flag bit of the PIR1 register is set whenever the EUSART transmitter is enabled and no character is being held for transmission in the TX1REG. In other words, the TXIF bit is only clear when the TSR is busy with a character and a new character has been queued for transmission in the TX1REG. The TXIF flag bit is not cleared immediately upon writing TX1REG. TXIF becomes valid in the second instruction cycle following the write execution. Polling TXIF immediately following the TX1REG write will return invalid results. The TXIF bit is read-only, it cannot be set or cleared by software.

The TXIF interrupt can be enabled by setting the TXIE interrupt enable bit of the PIE1 register. However, the TXIF flag bit will be set whenever the TX1REG is empty, regardless of the state of TXIE enable bit.

To use interrupts when transmitting data, set the TXIE bit only when there is more data to send. Clear the TXIE interrupt enable bit upon writing the last character of the transmission to the TX1REG.

# PIC16(L)F1717/8/9

## 31.1.1.5 TSR Status

The TRMT bit of the TX1STA register indicates the status of the TSR register. This is a read-only bit. The TRMT bit is set when the TSR register is empty and is cleared when a character is transferred to the TSR register from the TX1REG. The TRMT bit remains clear until all bits have been shifted out of the TSR register. No interrupt logic is tied to this bit, so the user has to poll this bit to determine the TSR status.

**Note:** The TSR register is not mapped in data memory, so it is not available to the user.

## 31.1.1.6 Transmitting 9-Bit Characters

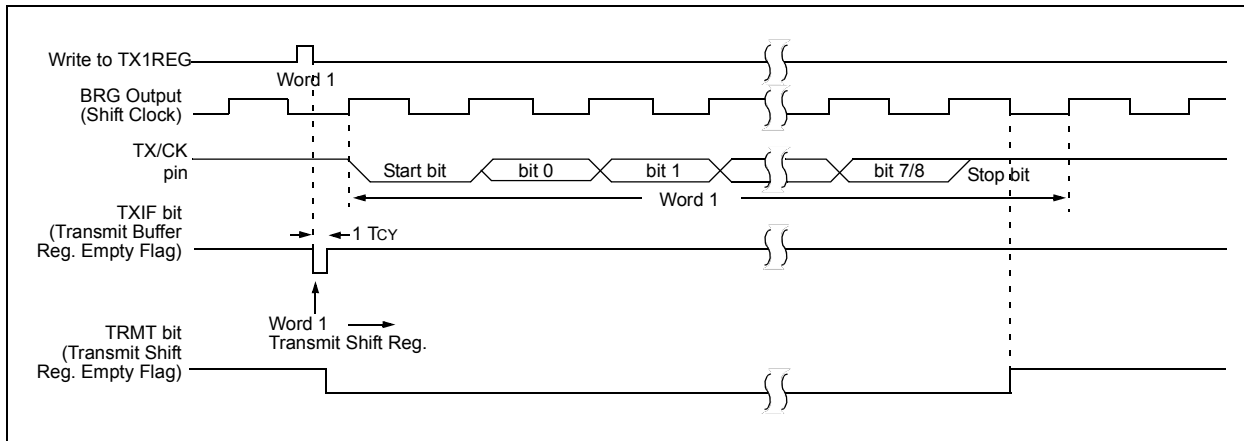
The EUSART supports 9-bit character transmissions. When the TX9 bit of the TX1STA register is set, the EUSART will shift nine bits out for each character transmitted. The TX9D bit of the TX1STA register is the ninth, and Most Significant data bit. When transmitting 9-bit data, the TX9D data bit must be written before writing the eight Least Significant bits into the TX1REG. All nine bits of data will be transferred to the TSR shift register immediately after the TX1REG is written.

A special 9-bit Address mode is available for use with multiple receivers. See [Section 31.1.2.7 “Address Detection”](#) for more information on the Address mode.

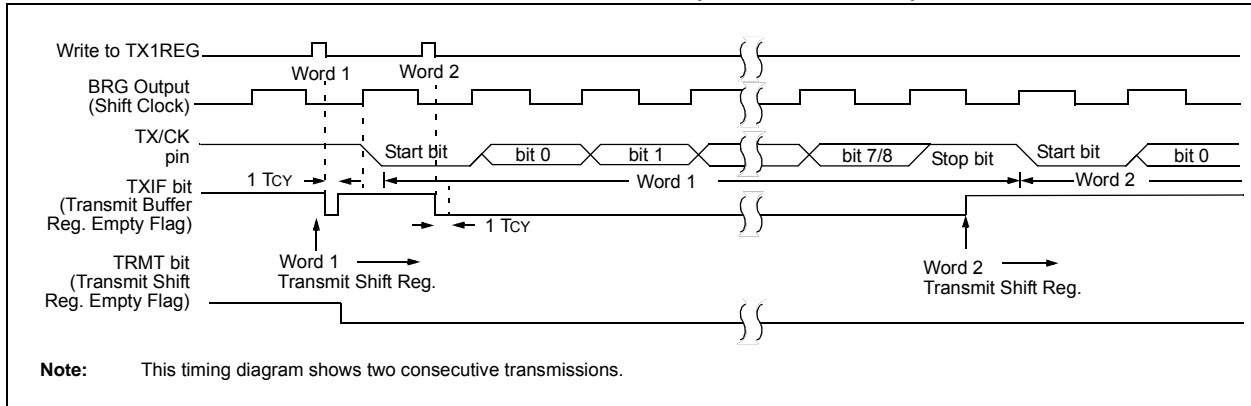
## 31.1.1.7 Asynchronous Transmission Setup

1. Initialize the SP1BRGH, SP1BRGL register pair and the BRGH and BRG16 bits to achieve the desired baud rate (see [Section 31.4 “EUSART Baud Rate Generator \(BRG\)”](#)).
2. Enable the asynchronous serial port by clearing the SYNC bit and setting the SPEN bit.
3. If 9-bit transmission is desired, set the TX9 control bit. A set ninth data bit will indicate that the eight Least Significant data bits are an address when the receiver is set for address detection.
4. Set SCKP bit if inverted transmit is desired.
5. Enable the transmission by setting the TXEN control bit. This will cause the TXIF interrupt bit to be set.
6. If interrupts are desired, set the TXIE interrupt enable bit of the PIE1 register. An interrupt will occur immediately provided that the GIE and PEIE bits of the INTCON register are also set.
7. If 9-bit transmission is selected, the ninth bit should be loaded into the TX9D data bit.
8. Load 8-bit data into the TX1REG register. This will start the transmission.

**FIGURE 31-3: ASYNCHRONOUS TRANSMISSION**



**FIGURE 31-4: ASYNCHRONOUS TRANSMISSION (BACK-TO-BACK)**



**TABLE 31-1: SUMMARY OF REGISTERS ASSOCIATED WITH ASYNCHRONOUS TRANSMISSION**

Name	Bit 7	Bit 6	Bit 5	Bit 4	Bit 3	Bit 2	Bit 1	Bit 0	Register on Page
BAUD1CON	ABDOVF	RCIDL	—	SCKP	BRG16	—	WUE	ABDEN	362
INTCON	GIE	PEIE	TMR0IE	INTE	IOCIE	TMR0IF	INTF	IOCIF	90
PIE1	TMR1GIE	ADIE	RCIE	TXIE	SSP1IE	CCP1IE	TMR2IE	TMR1IE	91
PIR1	TMR1GIF	ADIF	RCIF	TXIF	SSP1IF	CCP1IF	TMR2IF	TMR1IF	94
RC1STA	SPEN	RX9	SREN	CREN	ADDEN	FERR	OERR	RX9D	361
RxyPPS	—	—	—	RxyPPS<4:0>					153
SP1BRGL	SP1BRG<7:0>								363*
SP1BRGH	SP1BRG<15:8>								363*
TRISB	TRISB7	TRISB6	TRISB5	TRISB4	TRISB3	TRISB2	TRISB1	TRISB0	130
TRISC	TRISC7	TRISC6	TRISC5	TRISC4	TRISC3	TRISC2	TRISC1	TRISC0	135
TX1REG	EUSART Transmit Data Register								353*
TX1STA	CSRC	TX9	TXEN	SYNC	SENDB	BRGH	TRMT	TX9D	360

**Legend:** — = unimplemented location, read as '0'. Shaded cells are not used for asynchronous transmission.

\* Page provides register information.

# PIC16(L)F1717/8/9

## 31.1.2 EUSART ASYNCHRONOUS RECEIVER

The Asynchronous mode is typically used in RS-232 systems. The receiver block diagram is shown in [Figure 31-2](#). The data is received on the RX/DT pin and drives the data recovery block. The data recovery block is actually a high-speed shifter operating at 16 times the baud rate, whereas the serial Receive Shift Register (RSR) operates at the bit rate. When all eight or nine bits of the character have been shifted in, they are immediately transferred to a two character First-In-First-Out (FIFO) memory. The FIFO buffering allows reception of two complete characters and the start of a third character before software must start servicing the EUSART receiver. The FIFO and RSR registers are not directly accessible by software. Access to the received data is via the RC1REG register.

### 31.1.2.1 Enabling the Receiver

The EUSART receiver is enabled for asynchronous operation by configuring the following three control bits:

- CREN = 1
- SYNC = 0
- SPEN = 1

All other EUSART control bits are assumed to be in their default state.

Setting the CREN bit of the RC1STA register enables the receiver circuitry of the EUSART. Clearing the SYNC bit of the TX1STA register configures the EUSART for asynchronous operation. Setting the SPEN bit of the RC1STA register enables the EUSART. The programmer must set the corresponding TRIS bit to configure the RX/DT I/O pin as an input.

**Note:** If the RX/DT function is on an analog pin, the corresponding ANSEL bit must be cleared for the receiver to function.

### 31.1.2.2 Receiving Data

The receiver data recovery circuit initiates character reception on the falling edge of the first bit. The first bit, also known as the Start bit, is always a zero. The data recovery circuit counts one-half bit time to the center of the Start bit and verifies that the bit is still a zero. If it is not a zero then the data recovery circuit aborts character reception, without generating an error, and resumes looking for the falling edge of the Start bit. If the Start bit zero verification succeeds then the data recovery circuit counts a full bit time to the center of the next bit. The bit is then sampled by a majority detect circuit and the resulting '0' or '1' is shifted into the RSR. This repeats until all data bits have been sampled and shifted into the RSR. One final bit time is measured and the level sampled. This is the Stop bit, which is always a '1'. If the data recovery circuit samples a '0' in the Stop bit position then a framing error is set for this character, otherwise the framing error is cleared for this character. See [Section 31.1.2.4 "Receive Framing Error"](#) for more information on framing errors.

Immediately after all data bits and the Stop bit have been received, the character in the RSR is transferred to the EUSART receive FIFO and the RCIF interrupt flag bit of the PIR1 register is set. The top character in the FIFO is transferred out of the FIFO by reading the RC1REG register.

**Note:** If the receive FIFO is overrun, no additional characters will be received until the overrun condition is cleared. See [Section 31.1.2.5 "Receive Overrun Error"](#) for more information on overrun errors.

### 31.1.2.3 Receive Interrupts

The RCIF interrupt flag bit of the PIR1 register is set whenever the EUSART receiver is enabled and there is an unread character in the receive FIFO. The RCIF interrupt flag bit is read-only, it cannot be set or cleared by software.

RCIF interrupts are enabled by setting all of the following bits:

- RCIE, Interrupt Enable bit of the PIE1 register
- PEIE, Peripheral Interrupt Enable bit of the INTCON register
- GIE, Global Interrupt Enable bit of the INTCON register

The RCIF interrupt flag bit will be set when there is an unread character in the FIFO, regardless of the state of interrupt enable bits.

## 31.1.2.4 Receive Framing Error

Each character in the receive FIFO buffer has a corresponding framing error Status bit. A framing error indicates that a Stop bit was not seen at the expected time. The framing error status is accessed via the FERR bit of the RC1STA register. The FERR bit represents the status of the top unread character in the receive FIFO. Therefore, the FERR bit must be read before reading the RC1REG.

The FERR bit is read-only and only applies to the top unread character in the receive FIFO. A framing error (FERR = 1) does not preclude reception of additional characters. It is not necessary to clear the FERR bit. Reading the next character from the FIFO buffer will advance the FIFO to the next character and the next corresponding framing error.

The FERR bit can be forced clear by clearing the SPEN bit of the RC1STA register which resets the EUSART. Clearing the CREN bit of the RC1STA register does not affect the FERR bit. A framing error by itself does not generate an interrupt.

<p><b>Note:</b> If all receive characters in the receive FIFO have framing errors, repeated reads of the RC1REG will not clear the FERR bit.</p>
--

## 31.1.2.5 Receive Overrun Error

The receive FIFO buffer can hold two characters. An overrun error will be generated if a third character, in its entirety, is received before the FIFO is accessed. When this happens the OERR bit of the RC1STA register is set. The characters already in the FIFO buffer can be read but no additional characters will be received until the error is cleared. The error must be cleared by either clearing the CREN bit of the RC1STA register or by resetting the EUSART by clearing the SPEN bit of the RC1STA register.

## 31.1.2.6 Receiving 9-Bit Characters

The EUSART supports 9-bit character reception. When the RX9 bit of the RC1STA register is set the EUSART will shift nine bits into the RSR for each character received. The RX9D bit of the RC1STA register is the ninth and Most Significant data bit of the top unread character in the receive FIFO. When reading 9-bit data from the receive FIFO buffer, the RX9D data bit must be read before reading the eight Least Significant bits from the RC1REG.

## 31.1.2.7 Address Detection

A special Address Detection mode is available for use when multiple receivers share the same transmission line, such as in RS-485 systems. Address detection is enabled by setting the ADDEN bit of the RC1STA register.

Address detection requires 9-bit character reception. When address detection is enabled, only characters with the ninth data bit set will be transferred to the receive FIFO buffer, thereby setting the RCIF interrupt bit. All other characters will be ignored.

Upon receiving an address character, user software determines if the address matches its own. Upon address match, user software must disable address detection by clearing the ADDEN bit before the next Stop bit occurs. When user software detects the end of the message, determined by the message protocol used, software places the receiver back into the Address Detection mode by setting the ADDEN bit.

# PIC16(L)F1717/8/9

## 31.1.2.8 Asynchronous Reception Setup:

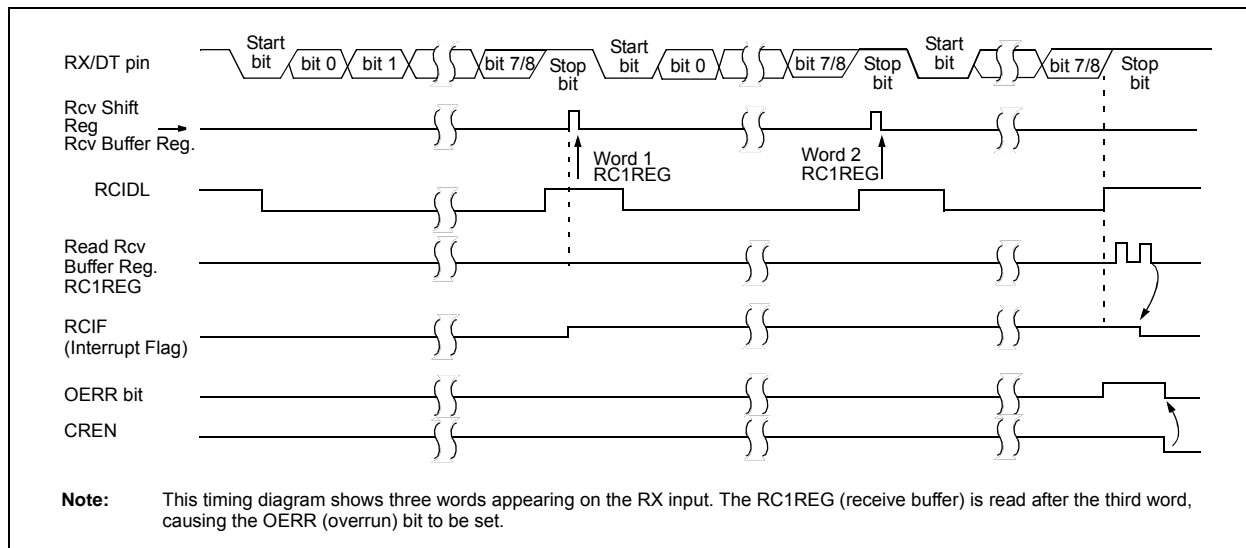
1. Initialize the SP1BRGH, SP1BRGL register pair and the BRGH and BRG16 bits to achieve the desired baud rate (see [Section 31.4 “EUSART Baud Rate Generator \(BRG\)”](#)).
2. Clear the ANSEL bit for the RX pin (if applicable).
3. Enable the serial port by setting the SPEN bit. The SYNC bit must be clear for asynchronous operation.
4. If interrupts are desired, set the RCIE bit of the PIE1 register and the GIE and PEIE bits of the INTCON register.
5. If 9-bit reception is desired, set the RX9 bit.
6. Enable reception by setting the CREN bit.
7. The RCIF interrupt flag bit will be set when a character is transferred from the RSR to the receive buffer. An interrupt will be generated if the RCIE interrupt enable bit was also set.
8. Read the RC1STA register to get the error flags and, if 9-bit data reception is enabled, the ninth data bit.
9. Get the received eight Least Significant data bits from the receive buffer by reading the RC1REG register.
10. If an overrun occurred, clear the OERR flag by clearing the CREN receiver enable bit.

## 31.1.2.9 9-bit Address Detection Mode Setup

This mode would typically be used in RS-485 systems. To set up an Asynchronous Reception with Address Detect Enable:

1. Initialize the SP1BRGH, SP1BRGL register pair and the BRGH and BRG16 bits to achieve the desired baud rate (see [Section 31.4 “EUSART Baud Rate Generator \(BRG\)”](#)).
2. Clear the ANSEL bit for the RX pin (if applicable).
3. Enable the serial port by setting the SPEN bit. The SYNC bit must be clear for asynchronous operation.
4. If interrupts are desired, set the RCIE bit of the PIE1 register and the GIE and PEIE bits of the INTCON register.
5. Enable 9-bit reception by setting the RX9 bit.
6. Enable address detection by setting the ADDEN bit.
7. Enable reception by setting the CREN bit.
8. The RCIF interrupt flag bit will be set when a character with the ninth bit set is transferred from the RSR to the receive buffer. An interrupt will be generated if the RCIE interrupt enable bit was also set.
9. Read the RC1STA register to get the error flags. The ninth data bit will always be set.
10. Get the received eight Least Significant data bits from the receive buffer by reading the RC1REG register. Software determines if this is the device's address.
11. If an overrun occurred, clear the OERR flag by clearing the CREN receiver enable bit.
12. If the device has been addressed, clear the ADDEN bit to allow all received data into the receive buffer and generate interrupts.

**FIGURE 31-5: ASYNCHRONOUS RECEPTION**



**TABLE 31-2: SUMMARY OF REGISTERS ASSOCIATED WITH ASYNCHRONOUS RECEPTION**

Name	Bit 7	Bit 6	Bit 5	Bit 4	Bit 3	Bit 2	Bit 1	Bit 0	Register on Page
ANSELB	—	—	ANSB5	ANSB4	ANSB3	ANSB2	ANSB1	ANSB0	131
ANSELC	ANSC7	ANSC6	ANSC5	ANSC4	ANSC3	ANSC2	—	—	136
BAUD1CON	ABDOVF	RCIDL	—	SCKP	BRG16	—	WUE	ABDEN	362
INTCON	GIE	PEIE	TMR0IE	INTE	IOCIE	TMR0IF	INTF	IOCIF	90
PIE1	TMR1GIE	ADIE	RCIE	TXIE	SSP1IE	CCP1IE	TMR2IE	TMR1IE	91
PIR1	TMR1GIF	ADIF	RCIF	TXIF	SSP1IF	CCP1IF	TMR2IF	TMR1IF	94
RC1REG	EUSART Receive Data Register								356*
RC1STA	SPEN	RX9	SREN	CREN	ADDEN	FERR	OERR	RX9D	361
RXPPS	—	—	—	RXPPS<4:0>					152
SP1BRGL	SP1BRG<7:0>								363
SP1BRGH	SP1BRG<15:8>								363
TRISB	TRISB7	TRISB6	TRISB5	TRISB4	TRISB3	TRISB2	TRISB1	TRISB0	130
TRISC	TRISC7	TRISC6	TRISC5	TRISC4	TRISC3	TRISC2	TRISC1	TRISC0	135
TX1STA	CSRC	TX9	TXEN	SYNC	SENDB	BRGH	TRMT	TX9D	360

**Legend:** — = unimplemented location, read as '0'. Shaded cells are not used for asynchronous reception.

\* Page provides register information.

## 31.2 Clock Accuracy with Asynchronous Operation

The factory calibrates the internal oscillator block output (INTOSC). However, the INTOSC frequency may drift as VDD or temperature changes, and this directly affects the asynchronous baud rate. Two methods may be used to adjust the baud rate clock, but both require a reference clock source of some kind.

The first (preferred) method uses the OSCTUNE register to adjust the INTOSC output. Adjusting the value in the OSCTUNE register allows for fine resolution changes to the system clock source. See [Section 6.2.2.3 “Internal Oscillator Frequency Adjustment”](#) for more information.

The other method adjusts the value in the Baud Rate Generator. This can be done automatically with the Auto-Baud Detect feature (see [Section 31.4.1 “Auto-Baud Detect”](#)). There may not be fine enough resolution when adjusting the Baud Rate Generator to compensate for a gradual change in the peripheral clock frequency.

# PIC16(L)F1717/8/9

## 31.3 Register Definitions: EUSART Control

### REGISTER 31-1: TX1STA: TRANSMIT STATUS AND CONTROL REGISTER

R/W-0	R/W-0/0	R/W-0/0	R/W-0/0	R/W-0/0	R/W-0/0	R-1/1	R/W-0/0
CSRC	TX9	TXEN <sup>(1)</sup>	SYNC	SENDB	BRGH	TRMT	TX9D
bit 7							bit 0

#### Legend:

R = Readable bit

W = Writable bit

U = Unimplemented bit, read as '0'

u = Bit is unchanged

x = Bit is unknown

-n/n = Value at POR and BOR/Value at all other Resets

'1' = Bit is set

'0' = Bit is cleared

- bit 7      **CSRC:** Clock Source Select bit  
Asynchronous mode:  
Don't care  
Synchronous mode:  
1 = Master mode (clock generated internally from BRG)  
0 = Slave mode (clock from external source)
- bit 6      **TX9:** 9-bit Transmit Enable bit  
1 = Selects 9-bit transmission  
0 = Selects 8-bit transmission
- bit 5      **TXEN:** Transmit Enable bit<sup>(1)</sup>  
1 = Transmit enabled  
0 = Transmit disabled
- bit 4      **SYNC:** EUSART Mode Select bit  
1 = Synchronous mode  
0 = Asynchronous mode
- bit 3      **SENDB:** Send Break Character bit  
Asynchronous mode:  
1 = Send Sync Break on next transmission (cleared by hardware upon completion)  
0 = Sync Break transmission completed  
Synchronous mode:  
Don't care
- bit 2      **BRGH:** High Baud Rate Select bit  
Asynchronous mode:  
1 = High speed  
0 = Low speed  
Synchronous mode:  
Unused in this mode
- bit 1      **TRMT:** Transmit Shift Register Status bit  
1 = TSR empty  
0 = TSR full
- bit 0      **TX9D:** Ninth bit of Transmit Data  
Can be address/data bit or a parity bit.

**Note 1:** SREN/CREN overrides TXEN in Sync mode.



# PIC16(L)F1717/8/9

## REGISTER 31-2: RC1STA: RECEIVE STATUS AND CONTROL REGISTER

R/W-0/0	R/W-0/0	R/W-0/0	R/W-0/0	R/W-0/0	R-0/0	R-0/0	R-0/0
SPEN	RX9	SREN	CREN	ADDEN	FERR	OERR	RX9D
bit 7							bit 0

### Legend:

R = Readable bit	W = Writable bit	U = Unimplemented bit, read as '0'
u = Bit is unchanged	x = Bit is unknown	-n/n = Value at POR and BOR/Value at all other Resets
'1' = Bit is set	'0' = Bit is cleared	

bit 7	<p><b>SPEN:</b> Serial Port Enable bit</p> <p>1 = Serial port enabled</p> <p>0 = Serial port disabled (held in Reset)</p>
bit 6	<p><b>RX9:</b> 9-Bit Receive Enable bit</p> <p>1 = Selects 9-bit reception</p> <p>0 = Selects 8-bit reception</p>
bit 5	<p><b>SREN:</b> Single Receive Enable bit</p> <p><u>Asynchronous mode:</u></p> <p>Don't care</p> <p><u>Synchronous mode – Master:</u></p> <p>1 = Enables single receive</p> <p>0 = Disables single receive</p> <p>This bit is cleared after reception is complete.</p> <p><u>Synchronous mode – Slave</u></p> <p>Don't care</p>
bit 4	<p><b>CREN:</b> Continuous Receive Enable bit</p> <p><u>Asynchronous mode:</u></p> <p>1 = Enables receiver</p> <p>0 = Disables receiver</p> <p><u>Synchronous mode:</u></p> <p>1 = Enables continuous receive until enable bit CREN is cleared (CREN overrides SREN)</p> <p>0 = Disables continuous receive</p>
bit 3	<p><b>ADDEN:</b> Address Detect Enable bit</p> <p><u>Asynchronous mode 9-bit (RX9 = 1):</u></p> <p>1 = Enables address detection, enable interrupt and load the receive buffer when RSR&lt;8&gt; is set</p> <p>0 = Disables address detection, all bytes are received and ninth bit can be used as parity bit</p> <p><u>Asynchronous mode 8-bit (RX9 = 0):</u></p> <p>Don't care</p>
bit 2	<p><b>FERR:</b> Framing Error bit</p> <p>1 = Framing error (can be updated by reading RC1REG register and receive next valid byte)</p> <p>0 = No framing error</p>
bit 1	<p><b>OERR:</b> Overrun Error bit</p> <p>1 = Overrun error (can be cleared by clearing bit CREN)</p> <p>0 = No overrun error</p>
bit 0	<p><b>RX9D:</b> Ninth bit of Received Data</p> <p>This can be address/data bit or a parity bit and must be calculated by user firmware.</p>

# PIC16(L)F1717/8/9

## REGISTER 31-3: BAUD1CON: BAUD RATE CONTROL REGISTER

R-0/0	R-1/1	U-0	R/W-0/0	R/W-0/0	U-0	R/W-0/0	R/W-0/0
ABDOVF	RCIDL	—	SCKP	BRG16	—	WUE	ABDEN
bit 7							bit 0

### Legend:

R = Readable bit	W = Writable bit	U = Unimplemented bit, read as '0'
u = Bit is unchanged	x = Bit is unknown	-n/n = Value at POR and BOR/Value at all other Resets
'1' = Bit is set	'0' = Bit is cleared	

- bit 7      **ABDOVF:** Auto-Baud Detect Overflow bit  
Asynchronous mode:  
 1 = Auto-baud timer overflowed  
 0 = Auto-baud timer did not overflow  
Synchronous mode:  
 Don't care
- bit 6      **RCIDL:** Receive Idle Flag bit  
Asynchronous mode:  
 1 = Receiver is Idle  
 0 = Start bit has been received and the receiver is receiving  
Synchronous mode:  
 Don't care
- bit 5      **Unimplemented:** Read as '0'
- bit 4      **SCKP:** Synchronous Clock Polarity Select bit  
Asynchronous mode:  
 1 = Transmit inverted data to the TX/CK pin  
 0 = Transmit non-inverted data to the TX/CK pin  
Synchronous mode:  
 1 = Data is clocked on rising edge of the clock  
 0 = Data is clocked on falling edge of the clock
- bit 3      **BRG16:** 16-bit Baud Rate Generator bit  
 1 = 16-bit Baud Rate Generator is used  
 0 = 8-bit Baud Rate Generator is used
- bit 2      **Unimplemented:** Read as '0'
- bit 1      **WUE:** Wake-up Enable bit  
Asynchronous mode:  
 1 = Receiver is waiting for a falling edge. No character will be received, byte RCIF will be set. WUE will automatically clear after RCIF is set.  
 0 = Receiver is operating normally  
Synchronous mode:  
 Don't care
- bit 0      **ABDEN:** Auto-Baud Detect Enable bit  
Asynchronous mode:  
 1 = Auto-Baud Detect mode is enabled (clears when auto-baud is complete)  
 0 = Auto-Baud Detect mode is disabled  
Synchronous mode:  
 Don't care

## 31.4 EUSART Baud Rate Generator (BRG)

The Baud Rate Generator (BRG) is an 8-bit or 16-bit timer that is dedicated to the support of both the asynchronous and synchronous EUSART operation. By default, the BRG operates in 8-bit mode. Setting the BRG16 bit of the BAUD1CON register selects 16-bit mode.

The SP1BRGH, SP1BRGL register pair determines the period of the free running baud rate timer. In Asynchronous mode the multiplier of the baud rate period is determined by both the BRGH bit of the TX1STA register and the BRG16 bit of the BAUD1CON register. In Synchronous mode, the BRGH bit is ignored.

Table 31-3 contains the formulas for determining the baud rate. Example 31-1 provides a sample calculation for determining the baud rate and baud rate error.

Typical baud rates and error values for various Asynchronous modes have been computed for your convenience and are shown in Table 31-5. It may be advantageous to use the high baud rate (BRGH = 1), or the 16-bit BRG (BRG16 = 1) to reduce the baud rate error. The 16-bit BRG mode is used to achieve slow baud rates for fast oscillator frequencies.

Writing a new value to the SP1BRGH, SP1BRGL register pair causes the BRG timer to be reset (or cleared). This ensures that the BRG does not wait for a timer overflow before outputting the new baud rate.

If the system clock is changed during an active receive operation, a receive error or data loss may result. To avoid this problem, check the status of the RCIDL bit to make sure that the receive operation is idle before changing the system clock.

### EXAMPLE 31-1: CALCULATING BAUD RATE ERROR

For a device with Fosc of 16 MHz, desired baud rate of 9600, Asynchronous mode, 8-bit BRG:

$$\text{Desired Baud Rate} = \frac{F_{osc}}{64(SP1BRGH:SP1BRGL) + 1}$$

Solving for SP1BRGH:SP1BRGL:

$$X = \frac{F_{osc}}{\text{Desired Baud Rate}} - 1$$

$$= \frac{16000000}{9600} - 1$$

$$= [25.042] = 25$$

$$\text{Calculated Baud Rate} = \frac{16000000}{64(25 + 1)}$$

$$= 9615$$

$$\text{Error} = \frac{\text{Calc. Baud Rate} - \text{Desired Baud Rate}}{\text{Desired Baud Rate}}$$

$$= \frac{(9615 - 9600)}{9600} = 0.16\%$$

# PIC16(L)F1717/8/9

**TABLE 31-3: BAUD RATE FORMULAS**

Configuration Bits			BRG/EUSART Mode	Baud Rate Formula
SYNC	BRG16	BRGH		
0	0	0	8-bit/Asynchronous	$F_{osc}/[64 (n+1)]$
0	0	1	8-bit/Asynchronous	$F_{osc}/[16 (n+1)]$
0	1	0	16-bit/Asynchronous	
0	1	1	16-bit/Asynchronous	$F_{osc}/[4 (n+1)]$
1	0	x	8-bit/Synchronous	
1	1	x	16-bit/Synchronous	

**Legend:** x = Don't care, n = value of SP1BRGH, SP1BRGL register pair.

**TABLE 31-4: SUMMARY OF REGISTERS ASSOCIATED WITH THE BAUD RATE GENERATOR**

Name	Bit 7	Bit 6	Bit 5	Bit 4	Bit 3	Bit 2	Bit 1	Bit 0	Register on Page
BAUD1CON	ABDOVF	RCIDL	—	SCKP	BRG16	—	WUE	ABDEN	<a href="#">362</a>
RC1STA	SPEN	RX9	SREN	CREN	ADDEN	FERR	OERR	RX9D	<a href="#">361</a>
SP1BRGL	SP1BRG<7:0>								<a href="#">363</a>
SP1BRGH	SP1BRG<15:8>								<a href="#">363</a>
TX1STA	CSRC	TX9	TXEN	SYNC	SENDB	BRGH	TRMT	TX9D	<a href="#">360</a>

**Legend:** — = unimplemented location, read as '0'. Shaded cells are not used for the Baud Rate Generator.

\* Page provides register information.

**TABLE 31-5: BAUD RATES FOR ASYNCHRONOUS MODES**

BAUD RATE	SYNC = 0, BRGH = 0, BRG16 = 0											
	Fosc = 32.000 MHz			Fosc = 20.000 MHz			Fosc = 18.432 MHz			Fosc = 11.0592 MHz		
	Actual Rate	% Error	SPBRG value (decimal)	Actual Rate	% Error	SPBRG value (decimal)	Actual Rate	% Error	SPBRG value (decimal)	Actual Rate	% Error	SPBRG value (decimal)
300	—	—	—	—	—	—	—	—	—	—	—	—
1200	—	—	—	1221	1.73	255	1200	0.00	239	1200	0.00	143
2400	2404	0.16	207	2404	0.16	129	2400	0.00	119	2400	0.00	71
9600	9615	0.16	51	9470	-1.36	32	9600	0.00	29	9600	0.00	17
10417	10417	0.00	47	10417	0.00	29	10286	-1.26	27	10165	-2.42	16
19.2k	19.23k	0.16	25	19.53k	1.73	15	19.20k	0.00	14	19.20k	0.00	8
57.6k	55.55k	-3.55	3	—	—	—	57.60k	0.00	7	57.60k	0.00	2
115.2k	—	—	—	—	—	—	—	—	—	—	—	—

BAUD RATE	SYNC = 0, BRGH = 0, BRG16 = 0											
	Fosc = 8.000 MHz			Fosc = 4.000 MHz			Fosc = 3.6864 MHz			Fosc = 1.000 MHz		
	Actual Rate	% Error	SPBRG value (decimal)	Actual Rate	% Error	SPBRG value (decimal)	Actual Rate	% Error	SPBRG value (decimal)	Actual Rate	% Error	SPBRG value (decimal)
300	—	—	—	300	0.16	207	300	0.00	191	300	0.16	51
1200	1202	0.16	103	1202	0.16	51	1200	0.00	47	1202	0.16	12
2400	2404	0.16	51	2404	0.16	25	2400	0.00	23	—	—	—
9600	9615	0.16	12	—	—	—	9600	0.00	5	—	—	—
10417	10417	0.00	11	10417	0.00	5	—	—	—	—	—	—
19.2k	—	—	—	—	—	—	19.20k	0.00	2	—	—	—
57.6k	—	—	—	—	—	—	57.60k	0.00	0	—	—	—
115.2k	—	—	—	—	—	—	—	—	—	—	—	—

BAUD RATE	SYNC = 0, BRGH = 1, BRG16 = 0											
	Fosc = 32.000 MHz			Fosc = 20.000 MHz			Fosc = 18.432 MHz			Fosc = 11.0592 MHz		
	Actual Rate	% Error	SPBRG value (decimal)	Actual Rate	% Error	SPBRG value (decimal)	Actual Rate	% Error	SPBRG value (decimal)	Actual Rate	% Error	SPBRG value (decimal)
300	—	—	—	—	—	—	—	—	—	—	—	—
1200	—	—	—	—	—	—	—	—	—	—	—	—
2400	—	—	—	—	—	—	—	—	—	—	—	—
9600	9615	0.16	207	9615	0.16	129	9600	0.00	119	9600	0.00	71
10417	10417	0.00	191	10417	0.00	119	10378	-0.37	110	10473	0.53	65
19.2k	19.23k	0.16	103	19.23k	0.16	64	19.20k	0.00	59	19.20k	0.00	35
57.6k	57.14k	-0.79	34	56.82k	-1.36	21	57.60k	0.00	19	57.60k	0.00	11
115.2k	117.64k	2.12	16	113.64k	-1.36	10	115.2k	0.00	9	115.2k	0.00	5

# PIC16(L)F1717/8/9

**TABLE 31-5: BAUD RATES FOR ASYNCHRONOUS MODES (CONTINUED)**

BAUD RATE	SYNC = 0, BRGH = 1, BRG16 = 0											
	Fosc = 8.000 MHz			Fosc = 4.000 MHz			Fosc = 3.6864 MHz			Fosc = 1.000 MHz		
	Actual Rate	% Error	SPBRG value (decimal)	Actual Rate	% Error	SPBRG value (decimal)	Actual Rate	% Error	SPBRG value (decimal)	Actual Rate	% Error	SPBRG value (decimal)
300	—	—	—	—	—	—	—	—	—	300	0.16	207
1200	—	—	—	1202	0.16	207	1200	0.00	191	1202	0.16	51
2400	2404	0.16	207	2404	0.16	103	2400	0.00	95	2404	0.16	25
9600	9615	0.16	51	9615	0.16	25	9600	0.00	23	—	—	—
10417	10417	0.00	47	10417	0.00	23	10473	0.53	21	10417	0.00	5
19.2k	19231	0.16	25	19.23k	0.16	12	19.2k	0.00	11	—	—	—
57.6k	55556	-3.55	8	—	—	—	57.60k	0.00	3	—	—	—
115.2k	—	—	—	—	—	—	115.2k	0.00	1	—	—	—

BAUD RATE	SYNC = 0, BRGH = 0, BRG16 = 1											
	Fosc = 32.000 MHz			Fosc = 20.000 MHz			Fosc = 18.432 MHz			Fosc = 11.0592 MHz		
	Actual Rate	% Error	SPBRG value (decimal)	Actual Rate	% Error	SPBRG value (decimal)	Actual Rate	% Error	SPBRG value (decimal)	Actual Rate	% Error	SPBRG value (decimal)
300	300.0	0.00	6666	300.0	-0.01	4166	300.0	0.00	3839	300.0	0.00	2303
1200	1200	-0.02	3332	1200	-0.03	1041	1200	0.00	959	1200	0.00	575
2400	2401	-0.04	832	2399	-0.03	520	2400	0.00	479	2400	0.00	287
9600	9615	0.16	207	9615	0.16	129	9600	0.00	119	9600	0.00	71
10417	10417	0.00	191	10417	0.00	119	10378	-0.37	110	10473	0.53	65
19.2k	19.23k	0.16	103	19.23k	0.16	64	19.20k	0.00	59	19.20k	0.00	35
57.6k	57.14k	-0.79	34	56.818	-1.36	21	57.60k	0.00	19	57.60k	0.00	11
115.2k	117.6k	2.12	16	113.636	-1.36	10	115.2k	0.00	9	115.2k	0.00	5

BAUD RATE	SYNC = 0, BRGH = 0, BRG16 = 1											
	Fosc = 8.000 MHz			Fosc = 4.000 MHz			Fosc = 3.6864 MHz			Fosc = 1.000 MHz		
	Actual Rate	% Error	SPBRG value (decimal)	Actual Rate	% Error	SPBRG value (decimal)	Actual Rate	% Error	SPBRG value (decimal)	Actual Rate	% Error	SPBRG value (decimal)
300	299.9	-0.02	1666	300.1	0.04	832	300.0	0.00	767	300.5	0.16	207
1200	1199	-0.08	416	1202	0.16	207	1200	0.00	191	1202	0.16	51
2400	2404	0.16	207	2404	0.16	103	2400	0.00	95	2404	0.16	25
9600	9615	0.16	51	9615	0.16	25	9600	0.00	23	—	—	—
10417	10417	0.00	47	10417	0.00	23	10473	0.53	21	10417	0.00	5
19.2k	19.23k	0.16	25	19.23k	0.16	12	19.20k	0.00	11	—	—	—
57.6k	55556	-3.55	8	—	—	—	57.60k	0.00	3	—	—	—
115.2k	—	—	—	—	—	—	115.2k	0.00	1	—	—	—

**TABLE 31-5: BAUD RATES FOR ASYNCHRONOUS MODES (CONTINUED)**

BAUD RATE	SYNC = 0, BRGH = 1, BRG16 = 1 or SYNC = 1, BRG16 = 1											
	Fosc = 32.000 MHz			Fosc = 20.000 MHz			Fosc = 18.432 MHz			Fosc = 11.0592 MHz		
	Actual Rate	% Error	SPBRG value (decimal)	Actual Rate	% Error	SPBRG value (decimal)	Actual Rate	% Error	SPBRG value (decimal)	Actual Rate	% Error	SPBRG value (decimal)
300	300.0	0.00	26666	300.0	0.00	16665	300.0	0.00	15359	300.0	0.00	9215
1200	1200	0.00	6666	1200	-0.01	4166	1200	0.00	3839	1200	0.00	2303
2400	2400	0.01	3332	2400	0.02	2082	2400	0.00	1919	2400	0.00	1151
9600	9604	0.04	832	9597	-0.03	520	9600	0.00	479	9600	0.00	287
10417	10417	0.00	767	10417	0.00	479	10425	0.08	441	10433	0.16	264
19.2k	19.18k	-0.08	416	19.23k	0.16	259	19.20k	0.00	239	19.20k	0.00	143
57.6k	57.55k	-0.08	138	57.47k	-0.22	86	57.60k	0.00	79	57.60k	0.00	47
115.2k	115.9k	0.64	68	116.3k	0.94	42	115.2k	0.00	39	115.2k	0.00	23

BAUD RATE	SYNC = 0, BRGH = 1, BRG16 = 1 or SYNC = 1, BRG16 = 1											
	Fosc = 8.000 MHz			Fosc = 4.000 MHz			Fosc = 3.6864 MHz			Fosc = 1.000 MHz		
	Actual Rate	% Error	SPBRG value (decimal)	Actual Rate	% Error	SPBRG value (decimal)	Actual Rate	% Error	SPBRG value (decimal)	Actual Rate	% Error	SPBRG value (decimal)
300	300.0	0.00	6666	300.0	0.01	3332	300.0	0.00	3071	300.1	0.04	832
1200	1200	-0.02	1666	1200	0.04	832	1200	0.00	767	1202	0.16	207
2400	2401	0.04	832	2398	0.08	416	2400	0.00	383	2404	0.16	103
9600	9615	0.16	207	9615	0.16	103	9600	0.00	95	9615	0.16	25
10417	10417	0	191	10417	0.00	95	10473	0.53	87	10417	0.00	23
19.2k	19.23k	0.16	103	19.23k	0.16	51	19.20k	0.00	47	19.23k	0.16	12
57.6k	57.14k	-0.79	34	58.82k	2.12	16	57.60k	0.00	15	—	—	—
115.2k	117.6k	2.12	16	111.1k	-3.55	8	115.2k	0.00	7	—	—	—

# PIC16(L)F1717/8/9

## 31.4.1 AUTO-BAUD DETECT

The EUSART module supports automatic detection and calibration of the baud rate.

In the Auto-Baud Detect (ABD) mode, the clock to the BRG is reversed. Rather than the BRG clocking the incoming RX signal, the RX signal is timing the BRG. The Baud Rate Generator is used to time the period of a received 55h (ASCII “U”) which is the Sync character for the LIN bus. The unique feature of this character is that it has five rising edges including the Stop bit edge.

Setting the ABDEN bit of the BAUD1CON register starts the auto-baud calibration sequence. While the ABD sequence takes place, the EUSART state machine is held in Idle. On the first rising edge of the receive line, after the Start bit, the SPBRG begins counting up using the BRG counter clock as shown in Figure 31-6. The fifth rising edge will occur on the RX pin at the end of the eighth bit period. At that time, an accumulated value totaling the proper BRG period is left in the SP1BRGH, SP1BRGL register pair, the ABDEN bit is automatically cleared and the RCIF interrupt flag is set. The value in the RC1REG needs to be read to clear the RCIF interrupt. RC1REG content should be discarded. When calibrating for modes that do not use the SP1BRGH register the user can verify that the SP1BRGL register did not overflow by checking for 00h in the SP1BRGH register.

The BRG auto-baud clock is determined by the BRG16 and BRGH bits as shown in Table 31-6. During ABD, both the SP1BRGH and SP1BRGL registers are used as a 16-bit counter, independent of the BRG16 bit setting. While calibrating the baud rate period, the SP1BRGH and SP1BRGL registers are clocked at

1/8th the BRG base clock rate. The resulting byte measurement is the average bit time when clocked at full speed.

**Note 1:** If the WUE bit is set with the ABDEN bit, auto-baud detection will occur on the byte following the Break character (see Section 31.4.3 “Auto-Wake-up on Break”).

**2:** It is up to the user to determine that the incoming character baud rate is within the range of the selected BRG clock source. Some combinations of oscillator frequency and EUSART baud rates are not possible.

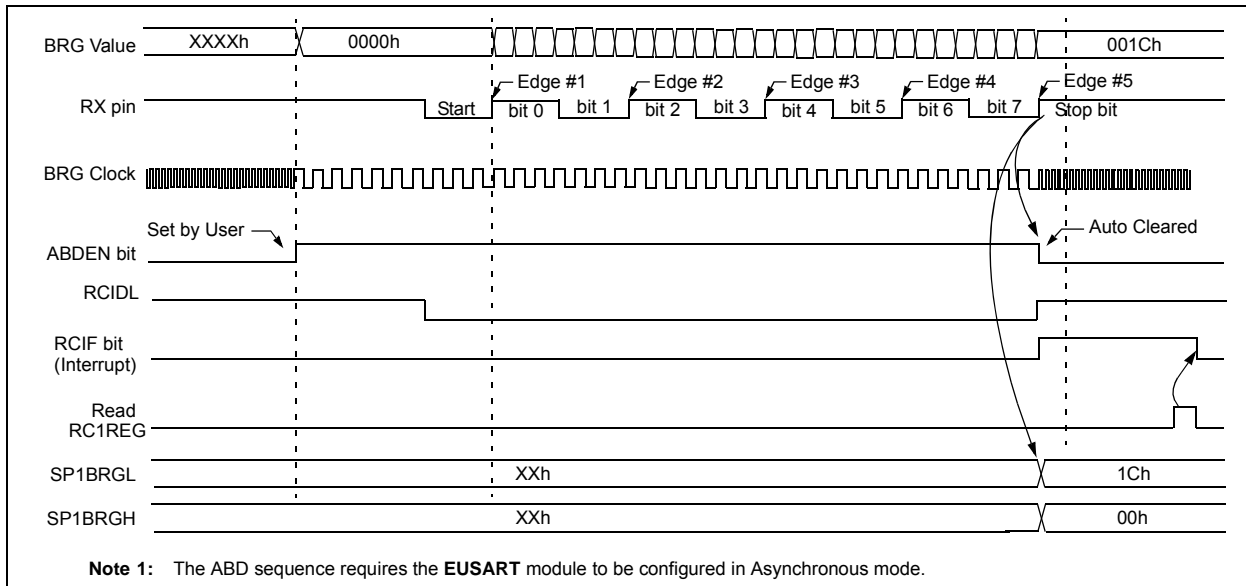
**3:** During the auto-baud process, the auto-baud counter starts counting at one. Upon completion of the auto-baud sequence, to achieve maximum accuracy, subtract 1 from the SP1BRGH:SP1BRGL register pair.

**TABLE 31-6: BRG COUNTER CLOCK RATES**

BRG16	BRGH	BRG Base Clock	BRG ABD Clock
0	0	Fosc/64	Fosc/512
0	1	Fosc/16	Fosc/128
1	0	Fosc/16	Fosc/128
1	1	Fosc/4	Fosc/32

**Note:** During the ABD sequence, SP1BRGL and SP1BRGH registers are both used as a 16-bit counter, independent of the BRG16 setting.

**FIGURE 31-6: AUTOMATIC BAUD RATE CALIBRATION**





## 31.4.2 AUTO-BAUD OVERFLOW

During the course of automatic baud detection, the ABDOVF bit of the BAUD1CON register will be set if the baud rate counter overflows before the fifth rising edge is detected on the RX pin. The ABDOVF bit indicates that the counter has exceeded the maximum count that can fit in the 16 bits of the SPxBRGH:SPxBRGL register pair. The overflow condition will set the RCIF flag. The counter continues to count until the fifth rising edge is detected on the RX pin. The RCIDL bit will remain false ('0') until the fifth rising edge at which time the RCIDL bit will be set. If the RC1REG is read after the overflow occurs, but before the fifth rising edge, the fifth rising edge will set the RCIF again.

Terminating the auto-baud process early to clear an overflow condition will prevent proper detection of the sync character's fifth rising edge. If any falling edges of the sync character have not yet occurred when the ABDEN bit is cleared, those will be falsely detected as start bits. The following steps are recommended to clear the overflow condition:

1. Read RCREG to clear RCIF.
2. If RCIDL is zero then wait for RCIF and repeat step 1.
3. Clear the ABDOVF bit.

## 31.4.3 AUTO-WAKE-UP ON BREAK

During Sleep mode, all clocks to the EUSART are suspended. Because of this, the Baud Rate Generator is inactive and a proper character reception cannot be performed. The Auto-Wake-up feature allows the controller to wake-up due to activity on the RX/DT line. This feature is available only in Asynchronous mode.

The Auto-Wake-up feature is enabled by setting the WUE bit of the BAUD1CON register. Once set, the normal receive sequence on RX/DT is disabled, and the EUSART remains in an Idle state, monitoring for a wake-up event independent of the CPU mode. A wake-up event consists of a high-to-low transition on the RX/DT line. (This coincides with the start of a Sync Break or a wake-up signal character for the LIN protocol.)

The EUSART module generates an RCIF interrupt coincident with the wake-up event. The interrupt is generated synchronously to the Q clocks in normal CPU operating modes (Figure 31-7), and asynchronously if the device is in Sleep mode (Figure 31-8). The interrupt condition is cleared by reading the RC1REG register.

The WUE bit is automatically cleared by the low-to-high transition on the RX line at the end of the Break. This signals to the user that the Break event is over. At this point, the EUSART module is in Idle mode waiting to receive the next character.

## 31.4.3.1 Special Considerations

### Break Character

To avoid character errors or character fragments during a wake-up event, the wake-up character must be all zeros.

When the wake-up is enabled the function works independent of the low time on the data stream. If the WUE bit is set and a valid non-zero character is received, the low time from the Start bit to the first rising edge will be interpreted as the wake-up event. The remaining bits in the character will be received as a fragmented character and subsequent characters can result in framing or overrun errors.

Therefore, the initial character in the transmission must be all '0's. This must be ten or more bit times, 13-bit times recommended for LIN bus, or any number of bit times for standard RS-232 devices.

### Oscillator Start-up Time

Oscillator start-up time must be considered, especially in applications using oscillators with longer start-up intervals (i.e., LP, XT or HS/PLL mode). The Sync Break (or wake-up signal) character must be of sufficient length, and be followed by a sufficient interval, to allow enough time for the selected oscillator to start and provide proper initialization of the EUSART.

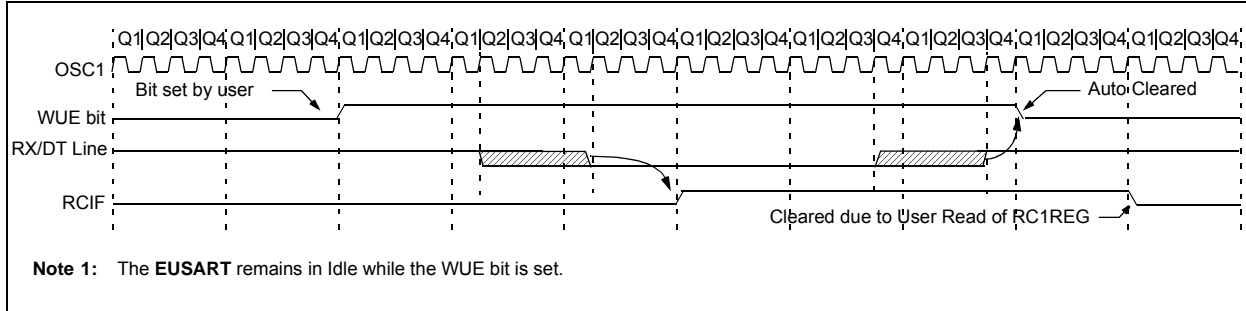
### WUE Bit

The wake-up event causes a receive interrupt by setting the RCIF bit. The WUE bit is cleared in hardware by a rising edge on RX/DT. The interrupt condition is then cleared in software by reading the RC1REG register and discarding its contents.

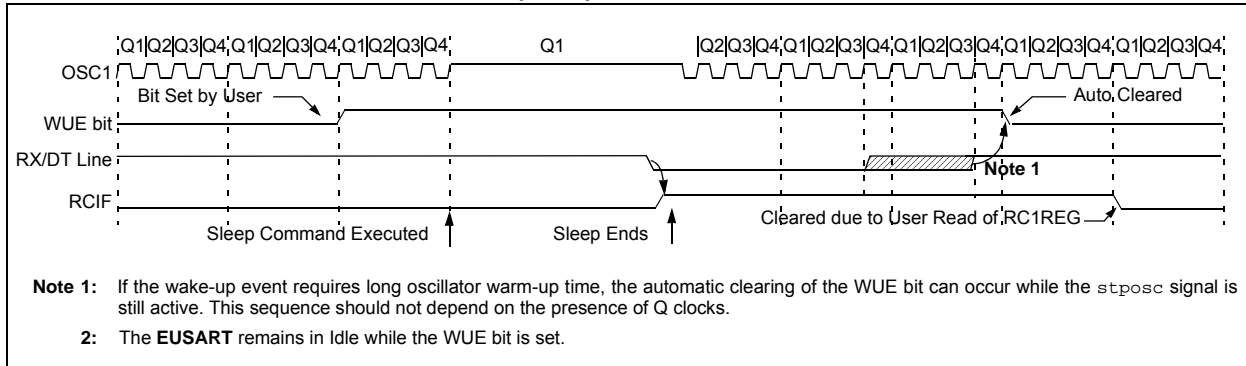
To ensure that no actual data is lost, check the RCIDL bit to verify that a receive operation is not in process before setting the WUE bit. If a receive operation is not occurring, the WUE bit may then be set just prior to entering the Sleep mode.

# PIC16(L)F1717/8/9

**FIGURE 31-7: AUTO-WAKE-UP BIT (WUE) TIMING DURING NORMAL OPERATION**



**FIGURE 31-8: AUTO-WAKE-UP BIT (WUE) TIMINGS DURING SLEEP**



## 31.4.4 BREAK CHARACTER SEQUENCE

The EUSART module has the capability of sending the special Break character sequences that are required by the LIN bus standard. A Break character consists of a Start bit, followed by 12 '0' bits and a Stop bit.

To send a Break character, set the SENDB and TXEN bits of the TX1STA register. The Break character transmission is then initiated by a write to the TX1REG. The value of data written to TX1REG will be ignored and all '0's will be transmitted.

The SENDB bit is automatically reset by hardware after the corresponding Stop bit is sent. This allows the user to preload the transmit FIFO with the next transmit byte following the Break character (typically, the Sync character in the LIN specification).

The TRMT bit of the TX1STA register indicates when the transmit operation is active or idle, just as it does during normal transmission. See [Figure 31-9](#) for the timing of the Break character sequence.

### 31.4.4.1 Break and Sync Transmit Sequence

The following sequence will start a message frame header made up of a Break, followed by an auto-baud Sync byte. This sequence is typical of a LIN bus master.

1. Configure the EUSART for the desired mode.
2. Set the TXEN and SENDB bits to enable the Break sequence.
3. Load the TX1REG with a dummy character to initiate transmission (the value is ignored).
4. Write '55h' to TX1REG to load the Sync character into the transmit FIFO buffer.
5. After the Break has been sent, the SENDB bit is reset by hardware and the Sync character is then transmitted.

When the TX1REG becomes empty, as indicated by the TXIF, the next data byte can be written to TX1REG.

## 31.4.5 RECEIVING A BREAK CHARACTER

The Enhanced EUSART module can receive a Break character in two ways.

The first method to detect a Break character uses the FERR bit of the RC1STA register and the received data as indicated by RC1REG. The Baud Rate Generator is assumed to have been initialized to the expected baud rate.

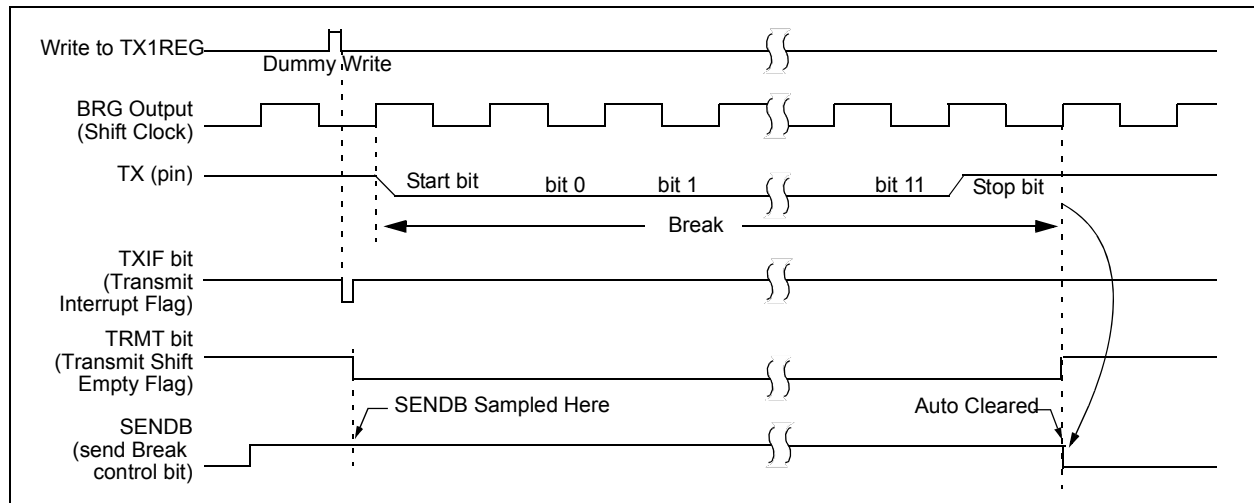
A Break character has been received when;

- RCIF bit is set
- FERR bit is set
- RC1REG = 00h

The second method uses the Auto-Wake-up feature described in [Section 31.4.3 "Auto-Wake-up on Break"](#). By enabling this feature, the EUSART will sample the next two transitions on RX/DT, cause an RCIF interrupt, and receive the next data byte followed by another interrupt.

Note that following a Break character, the user will typically want to enable the Auto-Baud Detect feature. For both methods, the user can set the ABDEN bit of the BAUD1CON register before placing the EUSART in Sleep mode.

**FIGURE 31-9: SEND BREAK CHARACTER SEQUENCE**



# PIC16(L)F1717/8/9

## 31.5 EUSART Synchronous Mode

Synchronous serial communications are typically used in systems with a single master and one or more slaves. The master device contains the necessary circuitry for baud rate generation and supplies the clock for all devices in the system. Slave devices can take advantage of the master clock by eliminating the internal clock generation circuitry.

There are two signal lines in Synchronous mode: a bidirectional data line and a clock line. Slaves use the external clock supplied by the master to shift the serial data into and out of their respective receive and transmit shift registers. Since the data line is bidirectional, synchronous operation is half-duplex only. Half-duplex refers to the fact that master and slave devices can receive and transmit data but not both simultaneously. The EUSART can operate as either a master or slave device.

Start and Stop bits are not used in synchronous transmissions.

### 31.5.1 SYNCHRONOUS MASTER MODE

The following bits are used to configure the EUSART for synchronous master operation:

- SYNC = 1
- CSRC = 1
- SREN = 0 (for transmit); SREN = 1 (for receive)
- CREN = 0 (for transmit); CREN = 1 (for receive)
- SPEN = 1

Setting the SYNC bit of the TX1STA register configures the device for synchronous operation. Setting the CSRC bit of the TX1STA register configures the device as a master. Clearing the SREN and CREN bits of the RC1STA register ensures that the device is in the Transmit mode, otherwise the device will be configured to receive. Setting the SPEN bit of the RC1STA register enables the EUSART.

#### 31.5.1.1 Master Clock

Synchronous data transfers use a separate clock line, which is synchronous with the data. A device configured as a master transmits the clock on the TX/CK line. The TX/CK pin output driver is automatically enabled when the EUSART is configured for synchronous transmit or receive operation. Serial data bits change on the leading edge to ensure they are valid at the trailing edge of each clock. One clock cycle is generated for each data bit. Only as many clock cycles are generated as there are data bits.

#### 31.5.1.2 Clock Polarity

A clock polarity option is provided for Microwire compatibility. Clock polarity is selected with the SCKP bit of the BAUD1CON register. Setting the SCKP bit sets the clock Idle state as high. When the SCKP bit is set, the data changes on the falling edge of each clock. Clearing the SCKP bit sets the Idle state as low. When the SCKP bit is cleared, the data changes on the rising edge of each clock.

#### 31.5.1.3 Synchronous Master Transmission

Data is transferred out of the device on the RX/DT pin. The RX/DT and TX/CK pin output drivers are automatically enabled when the EUSART is configured for synchronous master transmit operation.

A transmission is initiated by writing a character to the TX1REG register. If the TSR still contains all or part of a previous character the new character data is held in the TX1REG until the last bit of the previous character has been transmitted. If this is the first character, or the previous character has been completely flushed from the TSR, the data in the TX1REG is immediately transferred to the TSR. The transmission of the character commences immediately following the transfer of the data to the TSR from the TX1REG.

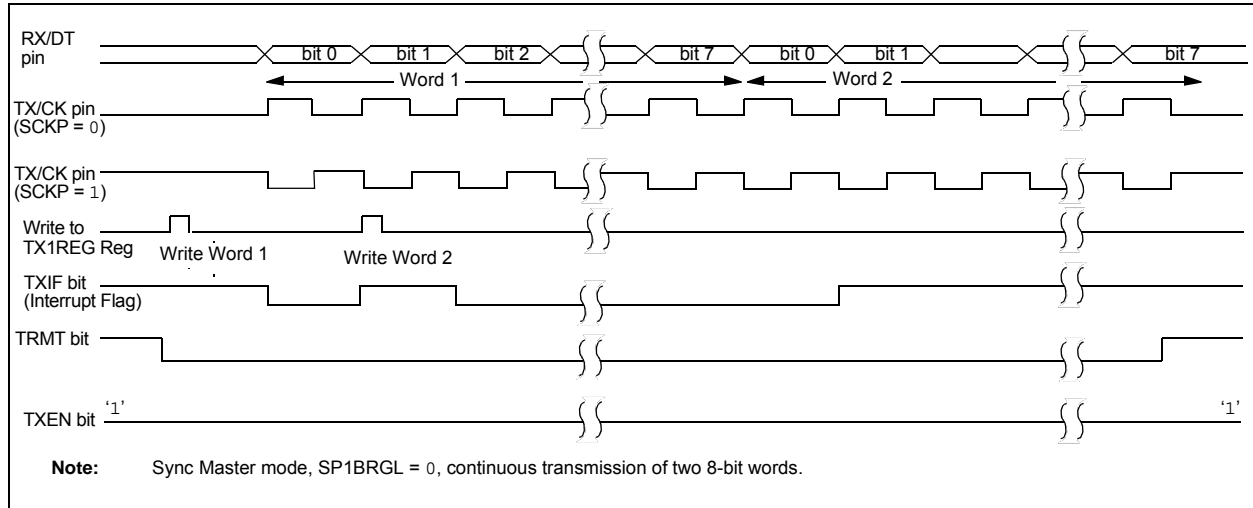
Each data bit changes on the leading edge of the master clock and remains valid until the subsequent leading clock edge.

**Note:** The TSR register is not mapped in data memory, so it is not available to the user.

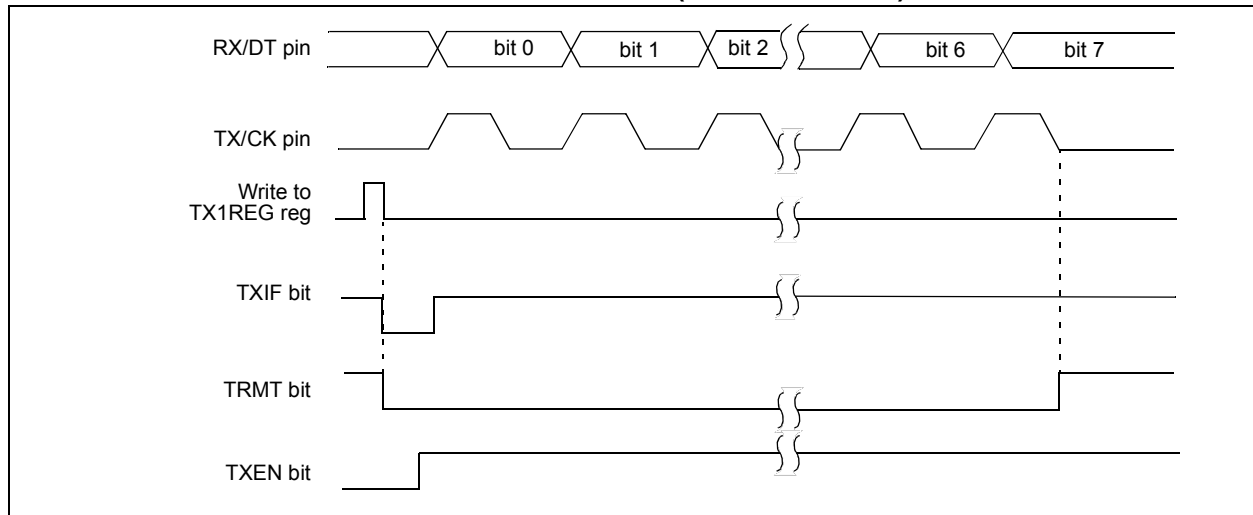
#### 31.5.1.4 Synchronous Master Transmission Setup

1. Initialize the SP1BRGH, SP1BRGL register pair and the BRGH and BRG16 bits to achieve the desired baud rate (see [Section 31.4 “EUSART Baud Rate Generator \(BRG\)”](#)).
2. Enable the synchronous master serial port by setting bits SYNC, SPEN and CSRC.
3. Disable Receive mode by clearing bits SREN and CREN.
4. Enable Transmit mode by setting the TXEN bit.
5. If 9-bit transmission is desired, set the TX9 bit.
6. If interrupts are desired, set the TXIE bit of the PIE1 register and the GIE and PEIE bits of the INTCON register.
7. If 9-bit transmission is selected, the ninth bit should be loaded in the TX9D bit.
8. Start transmission by loading data to the TX1REG register.

**FIGURE 31-10: SYNCHRONOUS TRANSMISSION**



**FIGURE 31-11: SYNCHRONOUS TRANSMISSION (THROUGH TXEN)**



# PIC16(L)F1717/8/9

**TABLE 31-7: SUMMARY OF REGISTERS ASSOCIATED WITH SYNCHRONOUS MASTER TRANSMISSION**

Name	Bit 7	Bit 6	Bit 5	Bit 4	Bit 3	Bit 2	Bit 1	Bit 0	Register on Page
ANSELB	—	—	ANSB5	ANSB4	ANSB3	ANSB2	ANSB1	ANSB0	131
ANSELC	ANSC7	ANSC6	ANSC5	ANSC4	ANSC3	ANSC2	—	—	136
BAUD1CON	ABDOVF	RCIDL	—	SCKP	BRG16	—	WUE	ABDEN	362
INTCON	GIE	PEIE	TMR0IE	INTE	IOCIE	TMR0IF	INTF	IOCIF	90
PIE1	TMR1GIE	ADIE	RCIE	TXIE	SSP1IE	CCP1IE	TMR2IE	TMR1IE	91
PIR1	TMR1GIF	ADIF	RCIF	TXIF	SSP1IF	CCP1IF	TMR2IF	TMR1IF	94
RC1STA	SPEN	RX9	SREN	CREN	ADDEN	FERR	OERR	RX9D	361
RxyPPS	—	—	—	RxyPPS<4:0>					153
SP1BRGL	SP1BRG<7:0>								363
SP1BRGH	SP1BRG<15:8>								363
TRISB	TRISB7	TRISB6	TRISB5	TRISB4	TRISB3	TRISB2	TRISB1	TRISB0	130
TRISC	TRISC7	TRISC6	TRISC5	TRISC4	TRISC3	TRISC2	TRISC1	TRISC0	135
TX1REG	EUSART Transmit Data Register								353*
TX1STA	CSRC	TX9	TXEN	SYNC	SENB	BRGH	TRMT	TX9D	360

**Legend:** — = unimplemented location, read as '0'. Shaded cells are not used for synchronous master transmission.

\* Page provides register information.

## 31.5.1.5 Synchronous Master Reception

Data is received at the RX/DT pin. The RX/DT pin output driver is automatically disabled when the EUSART is configured for synchronous master receive operation.

In Synchronous mode, reception is enabled by setting either the Single Receive Enable bit (SREN of the RC1STA register) or the Continuous Receive Enable bit (CREN of the RC1STA register).

When SREN is set and CREN is clear, only as many clock cycles are generated as there are data bits in a single character. The SREN bit is automatically cleared at the completion of one character. When CREN is set, clocks are continuously generated until CREN is cleared. If CREN is cleared in the middle of a character the CK clock stops immediately and the partial character is discarded. If SREN and CREN are both set, then SREN is cleared at the completion of the first character and CREN takes precedence.

To initiate reception, set either SREN or CREN. Data is sampled at the RX/DT pin on the trailing edge of the TX/CK clock pin and is shifted into the Receive Shift Register (RSR). When a complete character is received into the RSR, the RCIF bit is set and the character is automatically transferred to the two character receive FIFO. The Least Significant eight bits of the top character in the receive FIFO are available in RC1REG. The RCIF bit remains set as long as there are unread characters in the receive FIFO.

**Note:** If the RX/DT function is on an analog pin, the corresponding ANSEL bit must be cleared for the receiver to function.

## 31.5.1.6 Slave Clock

Synchronous data transfers use a separate clock line, which is synchronous with the data. A device configured as a slave receives the clock on the TX/CK line. The TX/CK pin output driver is automatically disabled when the device is configured for synchronous slave transmit or receive operation. Serial data bits change on the leading edge to ensure they are valid at the trailing edge of each clock. One data bit is transferred for each clock cycle. Only as many clock cycles should be received as there are data bits.

**Note:** If the device is configured as a slave and the TX/CK function is on an analog pin, the corresponding ANSEL bit must be cleared.

## 31.5.1.7 Receive Overrun Error

The receive FIFO buffer can hold two characters. An overrun error will be generated if a third character, in its entirety, is received before RC1REG is read to access the FIFO. When this happens the OERR bit of the RC1STA register is set. Previous data in the FIFO will not be overwritten. The two characters in the FIFO buffer can be read, however, no additional characters will be received until the error is cleared. The OERR bit can only be cleared by clearing the overrun condition. If the overrun error occurred when the SREN bit is set and CREN is clear then the error is cleared by reading RC1REG. If the overrun occurred when the CREN bit is set then the error condition is cleared by either clearing the CREN bit of the RC1STA register or by clearing the SPEN bit which resets the EUSART.

## 31.5.1.8 Receiving 9-Bit Characters

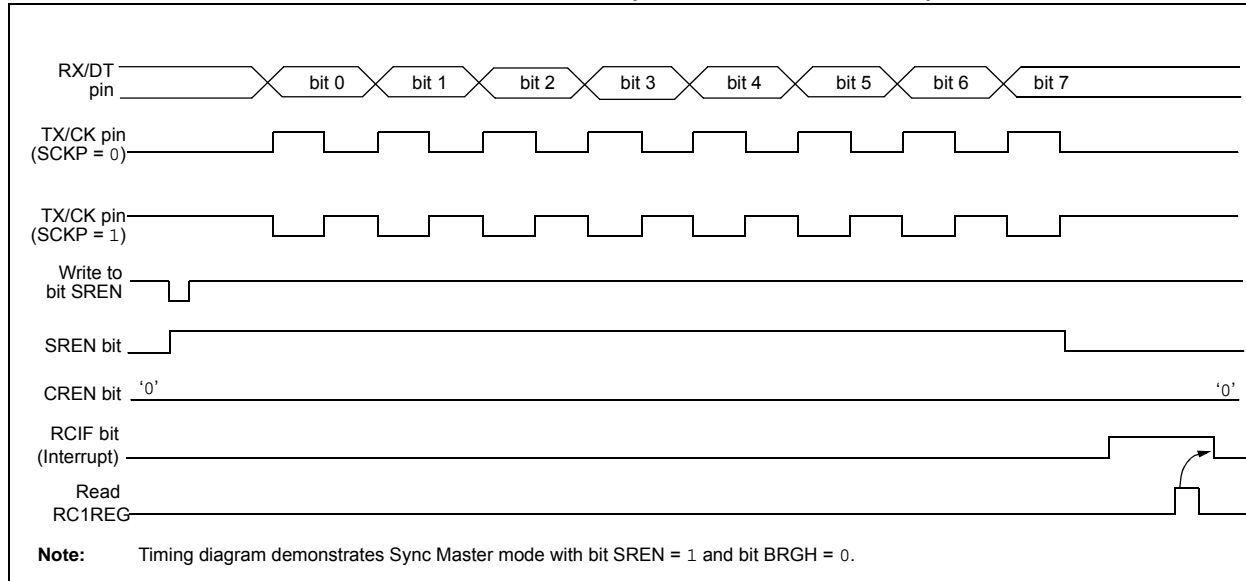
The EUSART supports 9-bit character reception. When the RX9 bit of the RC1STA register is set the EUSART will shift nine bits into the RSR for each character received. The RX9D bit of the RC1STA register is the ninth, and Most Significant, data bit of the top unread character in the receive FIFO. When reading 9-bit data from the receive FIFO buffer, the RX9D data bit must be read before reading the eight Least Significant bits from the RC1REG.

## 31.5.1.9 Synchronous Master Reception Setup

1. Initialize the SP1BRGH, SP1BRGL register pair for the appropriate baud rate. Set or clear the BRGH and BRG16 bits, as required, to achieve the desired baud rate.
2. Clear the ANSEL bit for the RX pin (if applicable).
3. Enable the synchronous master serial port by setting bits SYNC, SPEN and CSRC.
4. Ensure bits CREN and SREN are clear.
5. If interrupts are desired, set the RCIE bit of the PIE1 register and the GIE and PEIE bits of the INTCON register.
6. If 9-bit reception is desired, set bit RX9.
7. Start reception by setting the SREN bit or for continuous reception, set the CREN bit.
8. Interrupt flag bit RCIF will be set when reception of a character is complete. An interrupt will be generated if the enable bit RCIE was set.
9. Read the RC1STA register to get the ninth bit (if enabled) and determine if any error occurred during reception.
10. Read the 8-bit received data by reading the RC1REG register.
11. If an overrun error occurs, clear the error by either clearing the CREN bit of the RC1STA register or by clearing the SPEN bit which resets the EUSART.

# PIC16(L)F1717/8/9

**FIGURE 31-12: SYNCHRONOUS RECEPTION (MASTER MODE, SREN)**



**TABLE 31-8: SUMMARY OF REGISTERS ASSOCIATED WITH SYNCHRONOUS MASTER RECEPTION**

Name	Bit 7	Bit 6	Bit 5	Bit 4	Bit 3	Bit 2	Bit 1	Bit 0	Register on Page
ANSELB	—	—	ANSB5	ANSB4	ANSB3	ANSB2	ANSB1	ANSB0	131
ANSELC	ANSC7	ANSC6	ANSC5	ANSC4	ANSC3	ANSC2	—	—	136
BAUD1CON	ABDOVF	RCIDL	—	SCKP	BRG16	—	WUE	ABDEN	362
INTCON	GIE	PEIE	TMR0IE	INTE	IOCFIE	TMR0IF	INTF	IOCFIF	90
PIE1	TMR1GIE	ADIE	RCIE	TXIE	SSP1IE	CCP1IE	TMR2IE	TMR1IE	91
PIR1	TMR1GIF	ADIF	RCIF	TXIF	SSP1IF	CCP1IF	TMR2IF	TMR1IF	94
RC1REG	EUSART Receive Data Register								356*
RC1STA	SPEN	RX9	SREN	CREN	ADDEN	FERR	OERR	RX9D	361
RXPPS	—	—	—	RXPPS<4:0>					152
RxyPPS	—	—	—	RxyPPS<4:0>					153
SP1BRGL	SP1BRG<7:0>								363*
SP1BRGH	SP1BRG<15:8>								363*
TRISB	TRISB7	TRISB6	TRISB5	TRISB4	TRISB3	TRISB2	TRISB1	TRISB0	130
TRISC	TRISC7	TRISC6	TRISC5	TRISC4	TRISC3	TRISC2	TRISC1	TRISC0	135
TX1STA	CSRC	TX9	TXEN	SYNC	SENDB	BRGH	TRMT	TX9D	360

**Legend:** — = unimplemented location, read as '0'. Shaded cells are not used for synchronous master reception.

\* Page provides register information.



## 31.5.2 SYNCHRONOUS SLAVE MODE

The following bits are used to configure the EUSART for synchronous slave operation:

- SYNC = 1
- CSRC = 0
- SREN = 0 (for transmit); SREN = 1 (for receive)
- CREN = 0 (for transmit); CREN = 1 (for receive)
- SPEN = 1

Setting the SYNC bit of the TX1STA register configures the device for synchronous operation. Clearing the CSRC bit of the TX1STA register configures the device as a slave. Clearing the SREN and CREN bits of the RC1STA register ensures that the device is in the Transmit mode, otherwise the device will be configured to receive. Setting the SPEN bit of the RC1STA register enables the EUSART.

### 31.5.2.1 EUSART Synchronous Slave Transmit

The operation of the Synchronous Master and Slave modes are identical (see [Section 31.5.1.3 “Synchronous Master Transmission”](#)), except in the case of the Sleep mode.

If two words are written to the TX1REG and then the SLEEP instruction is executed, the following will occur:

1. The first character will immediately transfer to the TSR register and transmit.
2. The second word will remain in the TX1REG register.
3. The TXIF bit will not be set.
4. After the first character has been shifted out of TSR, the TX1REG register will transfer the second character to the TSR and the TXIF bit will now be set.
5. If the PEIE and TXIE bits are set, the interrupt will wake the device from Sleep and execute the next instruction. If the GIE bit is also set, the program will call the Interrupt Service Routine.

## 31.5.2.2 Synchronous Slave Transmission Setup

1. Set the SYNC and SPEN bits and clear the CSRC bit.
2. Clear the ANSEL bit for the CK pin (if applicable).
3. Clear the CREN and SREN bits.
4. If interrupts are desired, set the TXIE bit of the PIE1 register and the GIE and PEIE bits of the INTCON register.
5. If 9-bit transmission is desired, set the TX9 bit.
6. Enable transmission by setting the TXEN bit.
7. If 9-bit transmission is selected, insert the Most Significant bit into the TX9D bit.
8. Start transmission by writing the Least Significant eight bits to the TX1REG register.

# PIC16(L)F1717/8/9

**TABLE 31-9: SUMMARY OF REGISTERS ASSOCIATED WITH SYNCHRONOUS SLAVE TRANSMISSION**

Name	Bit 7	Bit 6	Bit 5	Bit 4	Bit 3	Bit 2	Bit 1	Bit 0	Register on Page
ANSELB	—	—	ANSB5	ANSB4	ANSB3	ANSB2	ANSB1	ANSB0	131
ANSELC	ANSC7	ANSC6	ANSC5	ANSC4	ANSC3	ANSC2	—	—	136
BAUD1CON	ABDOVF	RCIDL	—	SCKP	BRG16	—	WUE	ABDEN	362
CKPPS	—	—	—	CKPPS<4:0>					152
INTCON	GIE	PEIE	TMR0IE	INTE	IOCIE	TMR0IF	INTF	IOCIF	90
PIE1	TMR1GIE	ADIE	RCIE	TXIE	SSP1IE	CCP1IE	TMR2IE	TMR1IE	91
PIR1	TMR1GIF	ADIF	RCIF	TXIF	SSP1IF	CCP1IF	TMR2IF	TMR1IF	94
RC1STA	SPEN	RX9	SREN	CREN	ADDEN	FERR	OERR	RX9D	361
RxyPPS	—	—	—	RxyPPS<4:0>					153
TRISB	TRISB7	TRISB6	TRISB5	TRISB4	TRISB3	TRISB2	TRISB1	TRISB0	130
TRISC	TRISC7	TRISC6	TRISC5	TRISC4	TRISC3	TRISC2	TRISC1	TRISC0	135
TX1REG	EUSART Transmit Data Register								353*
TX1STA	CSRC	TX9	TXEN	SYNC	SENDB	BRGH	TRMT	TX9D	360

**Legend:** — = unimplemented location, read as '0'. Shaded cells are not used for synchronous slave transmission.

\* Page provides register information.

### 31.5.2.3 EUSART Synchronous Slave Reception

The operation of the Synchronous Master and Slave modes is identical ([Section 31.5.1.5 “Synchronous Master Reception”](#)), with the following exceptions:

- Sleep
- CREN bit is always set, therefore the receiver is never idle
- SREN bit, which is a “don’t care” in Slave mode

A character may be received while in Sleep mode by setting the CREN bit prior to entering Sleep. Once the word is received, the RSR register will transfer the data to the RC1REG register. If the RCIE enable bit is set, the interrupt generated will wake the device from Sleep and execute the next instruction. If the GIE bit is also set, the program will branch to the interrupt vector.

### 31.5.2.4 Synchronous Slave Reception Setup

1. Set the SYNC and SPEN bits and clear the CSRC bit.
2. Clear the ANSEL bit for both the CK and DT pins (if applicable).
3. If interrupts are desired, set the RCIE bit of the PIE1 register and the GIE and PEIE bits of the INTCON register.
4. If 9-bit reception is desired, set the RX9 bit.
5. Set the CREN bit to enable reception.
6. The RCIF bit will be set when reception is complete. An interrupt will be generated if the RCIE bit was set.
7. If 9-bit mode is enabled, retrieve the Most Significant bit from the RX9D bit of the RC1STA register.
8. Retrieve the eight Least Significant bits from the receive FIFO by reading the RC1REG register.
9. If an overrun error occurs, clear the error by either clearing the CREN bit of the RC1STA register or by clearing the SPEN bit which resets the EUSART.

**TABLE 31-10: SUMMARY OF REGISTERS ASSOCIATED WITH SYNCHRONOUS SLAVE RECEPTION**

Name	Bit 7	Bit 6	Bit 5	Bit 4	Bit 3	Bit 2	Bit 1	Bit 0	Register on Page
ANSELB	—	—	ANSB5	ANSB4	ANSB3	ANSB2	ANSB1	ANSB0	131
ANSELC	ANSC7	ANSC6	ANSC5	ANSC4	ANSC3	ANSC2	—	—	136
BAUD1CON	ABDOVF	RCIDL	—	SCKP	BRG16	—	WUE	ABDEN	362
CKPPS	—	—	—	CKPPS<4:0>					152
INTCON	GIE	PEIE	TMR0IE	INTE	IOIE	TMR0IF	INTF	IOCIF	90
PIE1	TMR1GIE	ADIE	RCIE	TXIE	SSP1IE	CCP1IE	TMR2IE	TMR1IE	91
PIR1	TMR1GIF	ADIF	RCIF	TXIF	SSP1IF	CCP1IF	TMR2IF	TMR1IF	94
RC1REG	EUSART Receive Data Register								356*
RC1STA	SPEN	RX9	SREN	CREN	ADDEN	FERR	OERR	RX9D	361
RXPPS	—	—	—	RXPPS<4:0>					152
TRISB	TRISB7	TRISB6	TRISB5	TRISB4	TRISB3	TRISB2	TRISB1	TRISB0	130
TRISC	TRISC7	TRISC6	TRISC5	TRISC4	TRISC3	TRISC2	TRISC1	TRISC0	135
TX1STA	CSRC	TX9	TXEN	SYNC	SENDB	BRGH	TRMT	TX9D	360

**Legend:** — = unimplemented location, read as '0'. Shaded cells are not used for synchronous slave reception.

\* Page provides register information.

## 31.6 EUSART Operation During Sleep

The EUSART will remain active during Sleep only in the Synchronous Slave mode. All other modes require the system clock and therefore cannot generate the necessary signals to run the Transmit or Receive Shift registers during Sleep.

Synchronous Slave mode uses an externally generated clock to run the Transmit and Receive Shift registers.

### 31.6.1 SYNCHRONOUS RECEIVE DURING SLEEP

To receive during Sleep, all the following conditions must be met before entering Sleep mode:

- RC1STA and TX1STA Control registers must be configured for Synchronous Slave Reception (see [Section 31.5.2.4 “Synchronous Slave Reception Setup”](#)).
- If interrupts are desired, set the RCIE bit of the PIE1 register and the GIE and PEIE bits of the INTCON register.
- The RCIF interrupt flag must be cleared by reading RC1REG to unload any pending characters in the receive buffer.

Upon entering Sleep mode, the device will be ready to accept data and clocks on the RX/DT and TX/CK pins, respectively. When the data word has been completely clocked in by the external device, the RCIF interrupt flag bit of the PIR1 register will be set. Thereby, waking the processor from Sleep.

Upon waking from Sleep, the instruction following the `SLEEP` instruction will be executed. If the Global Interrupt Enable (GIE) bit of the INTCON register is also set, then the Interrupt Service Routine at address 004h will be called.

### 31.6.2 SYNCHRONOUS TRANSMIT DURING SLEEP

To transmit during Sleep, all the following conditions must be met before entering Sleep mode:

- The RC1STA and TX1STA Control registers must be configured for synchronous slave transmission (see [Section 31.5.2.2 “Synchronous Slave Transmission Setup”](#)).
- The TXIF interrupt flag must be cleared by writing the output data to the TX1REG, thereby filling the TSR and transmit buffer.
- If interrupts are desired, set the TXIE bit of the PIE1 register and the PEIE bit of the INTCON register.

Upon entering Sleep mode, the device will be ready to accept clocks on TX/CK pin and transmit data on the RX/DT pin. When the data word in the TSR has been completely clocked out by the external device, the pending byte in the TX1REG will transfer to the TSR and the TXIF flag will be set. Thereby, waking the processor from Sleep. At this point, the TX1REG is available to accept another character for transmission, which will clear the TXIF flag.

Upon waking from Sleep, the instruction following the `SLEEP` instruction will be executed. If the Global Interrupt Enable (GIE) bit is also set then the Interrupt Service Routine at address 0004h will be called.

## 32.0 IN-CIRCUIT SERIAL PROGRAMMING (ICSP™)

ICSP programming allows customers to manufacture circuit boards with unprogrammed devices. Programming can be done after the assembly process, allowing the device to be programmed with the most recent firmware or a custom firmware. Five pins are needed for ICSP programming:

- ICSPCLK
- ICSPDAT
- MCLR/VPP
- VDD
- VSS

In Program/Verify mode the program memory, user IDs and the Configuration Words are programmed through serial communications. The ICSPDAT pin is a bidirectional I/O used for transferring the serial data and the ICSPCLK pin is the clock input. For more information on ICSP refer to the “PIC16(L)F170X Memory Programming Specification” (DS41683).

### 32.1 High-Voltage Programming Entry Mode

The device is placed into High-Voltage Programming Entry mode by holding the ICSPCLK and ICSPDAT pins low then raising the voltage on MCLR/VPP to  $V_{IH}$ .

### 32.2 Low-Voltage Programming Entry Mode

The Low-Voltage Programming Entry mode allows the PIC Flash MCUs to be programmed using VDD only, without high voltage. When the LVP bit of Configuration Words is set to '1', the low-voltage ICSP programming entry is enabled. To disable the Low-Voltage ICSP mode, the LVP bit must be programmed to '0'.

Entry into the Low-Voltage Programming Entry mode requires the following steps:

1.  $\overline{MCLR}$  is brought to  $V_{IL}$ .
2. A 32-bit key sequence is presented on ICSPDAT, while clocking ICSPCLK.

Once the key sequence is complete,  $\overline{MCLR}$  must be held at  $V_{IL}$  for as long as Program/Verify mode is to be maintained.

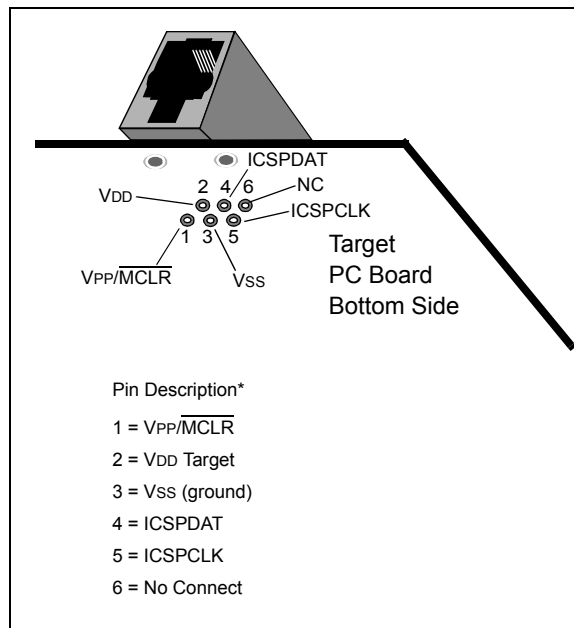
If low-voltage programming is enabled (LVP = 1), the MCLR Reset function is automatically enabled and cannot be disabled. See Section 5.5 “MCLR” for more information.

The LVP bit can only be reprogrammed to '0' by using the High-Voltage Programming mode.

## 32.3 Common Programming Interfaces

Connection to a target device is typically done through an ICSP header. A commonly found connector on development tools is the RJ-11 in the 6P6C (6-pin, 6-connector) configuration. See Figure 32-1.

**FIGURE 32-1: ICD RJ-11 STYLE CONNECTOR INTERFACE**



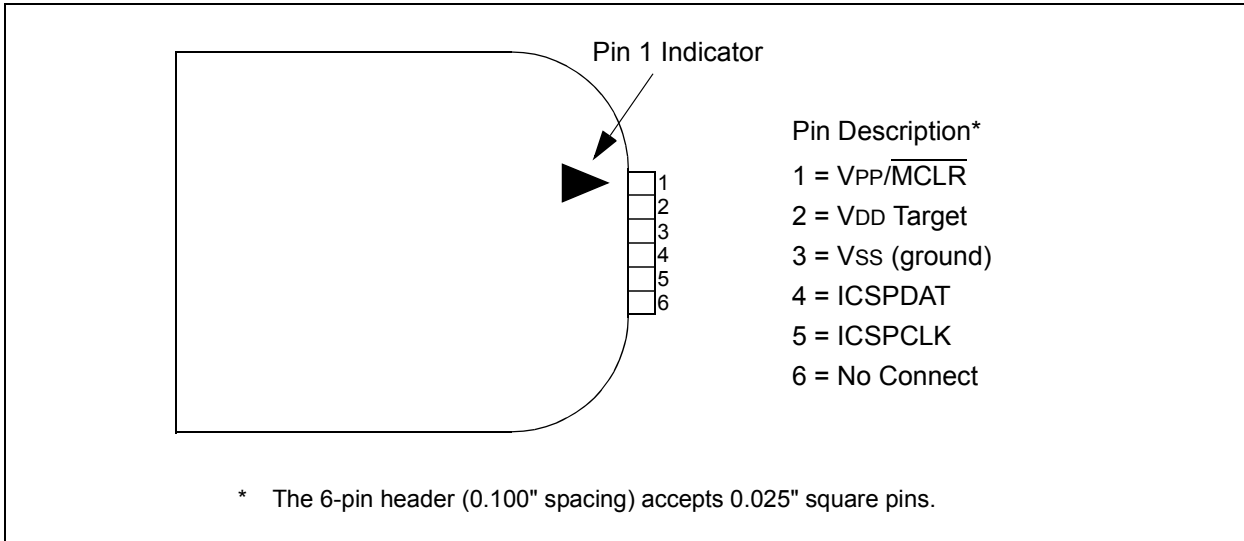
Another connector often found in use with the PICKit™ programmers is a standard 6-pin header with 0.1 inch spacing. Refer to Figure 32-2.

For additional interface recommendations, refer to your specific device programmer manual prior to PCB design.

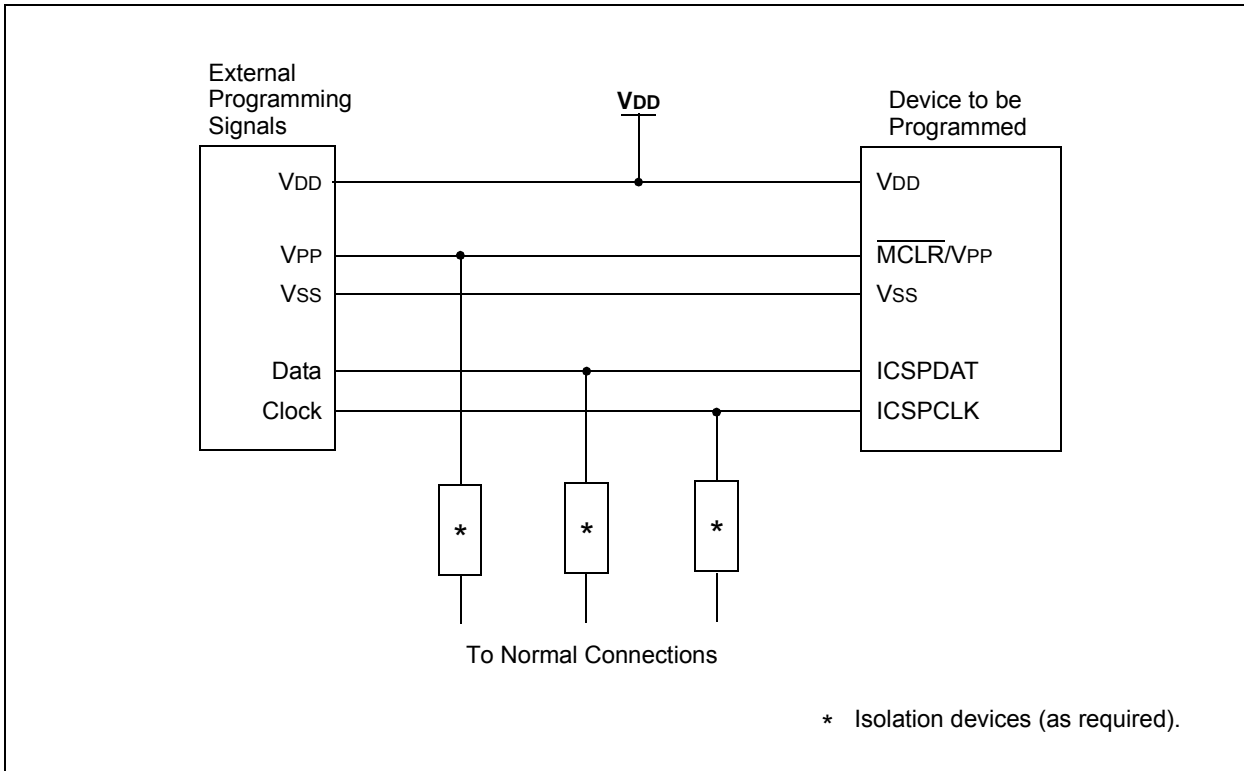
It is recommended that isolation devices be used to separate the programming pins from other circuitry. The type of isolation is highly dependent on the specific application and may include devices such as resistors, diodes, or even jumpers. See Figure 32-3 for more information.

# PIC16(L)F1717/8/9

**FIGURE 32-2: PICKit™ PROGRAMMER STYLE CONNECTOR INTERFACE**



**FIGURE 32-3: TYPICAL CONNECTION FOR ICSP™ PROGRAMMING**



## 33.0 INSTRUCTION SET SUMMARY

Each instruction is a 14-bit word containing the operation code (opcode) and all required operands. The opcodes are broken into three broad categories.

- Byte Oriented
- Bit Oriented
- Literal and Control

The literal and control category contains the most varied instruction word format.

Table 33-3 lists the instructions recognized by the MPASM™ assembler.

All instructions are executed within a single instruction cycle, with the following exceptions, which may take two or three cycles:

- Subroutine takes two cycles (CALL, CALLW)
- Returns from interrupts or subroutines take two cycles (RETURN, RETLW, RETFIE)
- Program branching takes two cycles (GOTO, BRA, BRW, BTFSS, BTFSC, DECFSZ, INCSFZ)
- One additional instruction cycle will be used when any instruction references an indirect file register and the file select register is pointing to program memory.

One instruction cycle consists of four oscillator cycles; for an oscillator frequency of 4 MHz, this gives a nominal instruction execution rate of 1 MHz.

All instruction examples use the format '0xhh' to represent a hexadecimal number, where 'h' signifies a hexadecimal digit.

## 33.1 Read-Modify-Write Operations

Any instruction that specifies a file register as part of the instruction performs a Read-Modify-Write (R-M-W) operation. The register is read, the data is modified, and the result is stored according to either the instruction, or the destination designator 'd'. A read operation is performed on a register even if the instruction writes to that register.

**TABLE 33-1: OPCODE FIELD DESCRIPTIONS**

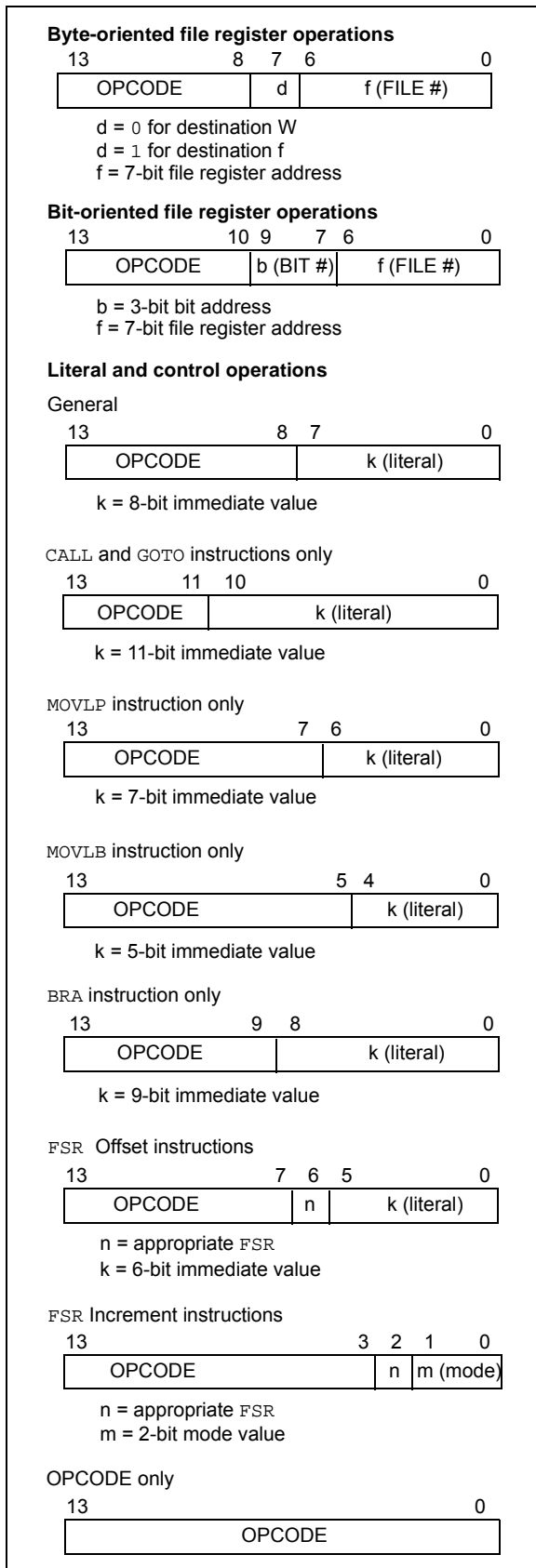
Field	Description
f	Register file address (0x00 to 0x7F)
W	Working register (accumulator)
b	Bit address within an 8-bit file register
k	Literal field, constant data or label
x	Don't care location (= 0 or 1). The assembler will generate code with x = 0. It is the recommended form of use for compatibility with all Microchip software tools.
d	Destination select; d = 0: store result in W, d = 1: store result in file register f. Default is d = 1.
n	FSR or INDF number. (0-1)
mm	Pre-post increment-decrement mode selection

**TABLE 33-2: ABBREVIATION DESCRIPTIONS**

Field	Description
PC	Program Counter
$\overline{TO}$	Time-Out bit
C	Carry bit
DC	Digit Carry bit
Z	Zero bit
PD	Power-Down bit

# PIC16(L)F1717/8/9

**FIGURE 33-1: GENERAL FORMAT FOR INSTRUCTIONS**





# PIC16(L)F1717/8/9

**TABLE 33-3: PIC16(L)F1717/8/9 INSTRUCTION SET**

Mnemonic, Operands	Description	Cycles	14-Bit Opcode				Status Affected	Notes	
			MSb	LSb					
<b>BYTE-ORIENTED FILE REGISTER OPERATIONS</b>									
ADDWF	f, d	Add W and f	1	00	0111	dfff	ffff	C, DC, Z	2
ADDWFC	f, d	Add with Carry W and f	1	11	1101	dfff	ffff	C, DC, Z	2
ANDWF	f, d	AND W with f	1	00	0101	dfff	ffff	Z	2
ASRF	f, d	Arithmetic Right Shift	1	11	0111	dfff	ffff	C, Z	2
LSLF	f, d	Logical Left Shift	1	11	0101	dfff	ffff	C, Z	2
LSRF	f, d	Logical Right Shift	1	11	0110	dfff	ffff	C, Z	2
CLRF	f	Clear f	1	00	0001	1fff	ffff	Z	2
CLRW	–	Clear W	1	00	0001	0000	00xx	Z	
COMF	f, d	Complement f	1	00	1001	dfff	ffff	Z	2
DECf	f, d	Decrement f	1	00	0011	dfff	ffff	Z	2
INCF	f, d	Increment f	1	00	1010	dfff	ffff	Z	2
IORWF	f, d	Inclusive OR W with f	1	00	0100	dfff	ffff	Z	2
MOVF	f, d	Move f	1	00	1000	dfff	ffff	Z	2
MOVWF	f	Move W to f	1	00	0000	1fff	ffff		2
RLF	f, d	Rotate Left f through Carry	1	00	1101	dfff	ffff	C	2
RRF	f, d	Rotate Right f through Carry	1	00	1100	dfff	ffff	C	2
SUBWF	f, d	Subtract W from f	1	00	0010	dfff	ffff	C, DC, Z	2
SUBWFB	f, d	Subtract with Borrow W from f	1	11	1011	dfff	ffff	C, DC, Z	2
SWAPF	f, d	Swap nibbles in f	1	00	1110	dfff	ffff		2
XORWF	f, d	Exclusive OR W with f	1	00	0110	dfff	ffff	Z	2
<b>BYTE ORIENTED SKIP OPERATIONS</b>									
DECFSZ	f, d	Decrement f, Skip if 0	1(2)	00	1011	dfff	ffff		1, 2
INCFSZ	f, d	Increment f, Skip if 0	1(2)	00	1111	dfff	ffff		1, 2
<b>BIT-ORIENTED FILE REGISTER OPERATIONS</b>									
BCF	f, b	Bit Clear f	1	01	00bb	bfff	ffff		2
BSF	f, b	Bit Set f	1	01	01bb	bfff	ffff		2
<b>BIT-ORIENTED SKIP OPERATIONS</b>									
BTFSC	f, b	Bit Test f, Skip if Clear	1 (2)	01	10bb	bfff	ffff		1, 2
BTFSS	f, b	Bit Test f, Skip if Set	1 (2)	01	11bb	bfff	ffff		1, 2
<b>LITERAL OPERATIONS</b>									
ADDLW	k	Add literal and W	1	11	1110	kkkk	kkkk	C, DC, Z	
ANDLW	k	AND literal with W	1	11	1001	kkkk	kkkk	Z	
IORLW	k	Inclusive OR literal with W	1	11	1000	kkkk	kkkk	Z	
MOVLB	k	Move literal to BSR	1	00	0000	001k	kkkk		
MOVLp	k	Move literal to PCLATH	1	11	0001	1kkk	kkkk		
MOVLW	k	Move literal to W	1	11	0000	kkkk	kkkk		
SUBLW	k	Subtract W from literal	1	11	1100	kkkk	kkkk	C, DC, Z	
XORLW	k	Exclusive OR literal with W	1	11	1010	kkkk	kkkk	Z	
<b>CONTROL OPERATIONS</b>									
BRA	k	Relative Branch	2	11	001k	kkkk	kkkk		
BRW	–	Relative Branch with W	2	00	0000	0000	1011		
CALL	k	Call Subroutine	2	10	0kkk	kkkk	kkkk		
CALLW	–	Call Subroutine with W	2	00	0000	0000	1010		
GOTO	k	Go to address	2	10	1kkk	kkkk	kkkk		
RETFIE	k	Return from interrupt	2	00	0000	0000	1001		
RETLW	k	Return with literal in W	2	11	0100	kkkk	kkkk		
RETURN	–	Return from Subroutine	2	00	0000	0000	1000		

- Note 1:** If the Program Counter (PC) is modified, or a conditional test is true, the instruction requires two cycles. The second cycle is executed as a NOP.
- Note 2:** If this instruction addresses an INDF register and the MSb of the corresponding FSR is set, this instruction will require one additional instruction cycle.

# PIC16(L)F1717/8/9

**TABLE 33-3: PIC16(L)F1717/8/9 INSTRUCTION SET (CONTINUED)**

Mnemonic, Operands	Description	Cycles	14-Bit Opcode				Status Affected	Notes	
			MSb	LSb					
<b>INHERENT OPERATIONS</b>									
CLRWDT	–	Clear Watchdog Timer	1	00	0000	0110	0100	$\overline{TO}$ , $\overline{PD}$	
NOP	–	No Operation	1	00	0000	0000	0000		
OPTION	–	Load OPTION_REG register with W	1	00	0000	0110	0010		
RESET	–	Software device Reset	1	00	0000	0000	0001		
SLEEP	–	Go into Standby mode	1	00	0000	0110	0011	$\overline{TO}$ , $\overline{PD}$	
TRIS	f	Load TRIS register with W	1	00	0000	0110	0fff		
<b>C-COMPILER OPTIMIZED</b>									
ADDFSR	n, k	Add Literal k to FSRn	1	11	0001	0nkk	kkkk		
MOVIW	n mm	Move Indirect FSRn to W with pre/post inc/dec modifier, mm	1	00	0000	0001	0nmm	Z	<b>2, 3</b>
	k[n]	Move INDFn to W, Indexed Indirect.	1	11	1111	0nkk	kkkk	Z	<b>2</b>
MOVWI	n mm	Move W to Indirect FSRn with pre/post inc/dec modifier, mm	1	00	0000	0001	1nmm		<b>2, 3</b>
	k[n]	Move W to INDFn, Indexed Indirect.	1	11	1111	1nkk	kkkk		<b>2</b>

- Note 1:** If the Program Counter (PC) is modified, or a conditional test is true, the instruction requires two cycles. The second cycle is executed as a NOP.
- Note 2:** If this instruction addresses an INDF register and the MSb of the corresponding FSR is set, this instruction will require one additional instruction cycle.

## 33.2 Instruction Descriptions

<b>ADDFSR</b>	<b>Add Literal to FSRn</b>
Syntax:	[ <i>label</i> ] ADDFSR FSRn, k
Operands:	-32 ≤ k ≤ 31 n ∈ [ 0, 1 ]
Operation:	FSR(n) + k → FSR(n)
Status Affected:	None
Description:	The signed 6-bit literal 'k' is added to the contents of the FSRnH:FSRnL register pair.  FSRn is limited to the range 0000h-FFFFh. Moving beyond these bounds will cause the FSR to wrap-around.

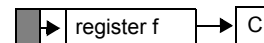
<b>ANDLW</b>	<b>AND literal with W</b>
Syntax:	[ <i>label</i> ] ANDLW k
Operands:	0 ≤ k ≤ 255
Operation:	(W) .AND. (k) → (W)
Status Affected:	Z
Description:	The contents of W register are AND'ed with the 8-bit literal 'k'. The result is placed in the W register.

<b>ADDLW</b>	<b>Add literal and W</b>
Syntax:	[ <i>label</i> ] ADDLW k
Operands:	0 ≤ k ≤ 255
Operation:	(W) + k → (W)
Status Affected:	C, DC, Z
Description:	The contents of the W register are added to the 8-bit literal 'k' and the result is placed in the W register.

<b>ANDWF</b>	<b>AND W with f</b>
Syntax:	[ <i>label</i> ] ANDWF f,d
Operands:	0 ≤ f ≤ 127 d ∈ [0,1]
Operation:	(W) .AND. (f) → (destination)
Status Affected:	Z
Description:	AND the W register with register 'f'. If 'd' is '0', the result is stored in the W register. If 'd' is '1', the result is stored back in register 'f'.

<b>ADDWF</b>	<b>Add W and f</b>
Syntax:	[ <i>label</i> ] ADDWF f,d
Operands:	0 ≤ f ≤ 127 d ∈ [0,1]
Operation:	(W) + (f) → (destination)
Status Affected:	C, DC, Z
Description:	Add the contents of the W register with register 'f'. If 'd' is '0', the result is stored in the W register. If 'd' is '1', the result is stored back in register 'f'.

<b>ASRF</b>	<b>Arithmetic Right Shift</b>
Syntax:	[ <i>label</i> ] ASRF f {,d}
Operands:	0 ≤ f ≤ 127 d ∈ [0,1]
Operation:	(f<7>) → dest<7> (f<7:1>) → dest<6:0>, (f<0>) → C,
Status Affected:	C, Z
Description:	The contents of register 'f' are shifted one bit to the right through the Carry flag. The MSb remains unchanged. If 'd' is '0', the result is placed in W. If 'd' is '1', the result is stored back in register 'f'.



<b>ADDWFC</b>	<b>ADD W and CARRY bit to f</b>
Syntax:	[ <i>label</i> ] ADDWFC f {,d}
Operands:	0 ≤ f ≤ 127 d ∈ [0,1]
Operation:	(W) + (f) + (C) → dest
Status Affected:	C, DC, Z
Description:	Add W, the Carry flag and data memory location 'f'. If 'd' is '0', the result is placed in W. If 'd' is '1', the result is placed in data memory location 'f'.

# PIC16(L)F1717/8/9

---

<b>BCF</b>	<b>Bit Clear f</b>
Syntax:	[ <i>label</i> ] BCF f,b
Operands:	$0 \leq f \leq 127$ $0 \leq b \leq 7$
Operation:	$0 \rightarrow (f<b>)$
Status Affected:	None
Description:	Bit 'b' in register 'f' is cleared.

<b>BTFSK</b>	<b>Bit Test f, Skip if Clear</b>
Syntax:	[ <i>label</i> ] BTFSK f,b
Operands:	$0 \leq f \leq 127$ $0 \leq b \leq 7$
Operation:	skip if $(f<b>) = 0$
Status Affected:	None
Description:	If bit 'b' in register 'f' is '1', the next instruction is executed. If bit 'b', in register 'f', is '0', the next instruction is discarded, and a NOP is executed instead, making this a 2-cycle instruction.

<b>BRA</b>	<b>Relative Branch</b>
Syntax:	[ <i>label</i> ] BRA label [ <i>label</i> ] BRA \$+k
Operands:	$-256 \leq \text{label} - \text{PC} + 1 \leq 255$ $-256 \leq k \leq 255$
Operation:	$(\text{PC}) + 1 + k \rightarrow \text{PC}$
Status Affected:	None
Description:	Add the signed 9-bit literal 'k' to the PC. Since the PC will have incremented to fetch the next instruction, the new address will be $\text{PC} + 1 + k$ . This instruction is a 2-cycle instruction. This branch has a limited range.

<b>BTFSF</b>	<b>Bit Test f, Skip if Set</b>
Syntax:	[ <i>label</i> ] BTFSF f,b
Operands:	$0 \leq f \leq 127$ $0 \leq b < 7$
Operation:	skip if $(f<b>) = 1$
Status Affected:	None
Description:	If bit 'b' in register 'f' is '0', the next instruction is executed. If bit 'b' is '1', then the next instruction is discarded and a NOP is executed instead, making this a 2-cycle instruction.

<b>BRW</b>	<b>Relative Branch with W</b>
Syntax:	[ <i>label</i> ] BRW
Operands:	None
Operation:	$(\text{PC}) + (W) \rightarrow \text{PC}$
Status Affected:	None
Description:	Add the contents of W (unsigned) to the PC. Since the PC will have incremented to fetch the next instruction, the new address will be $\text{PC} + 1 + (W)$ . This instruction is a 2-cycle instruction.

<b>BSF</b>	<b>Bit Set f</b>
Syntax:	[ <i>label</i> ] BSF f,b
Operands:	$0 \leq f \leq 127$ $0 \leq b \leq 7$
Operation:	$1 \rightarrow (f<b>)$
Status Affected:	None
Description:	Bit 'b' in register 'f' is set.

## CALL Call Subroutine

**Syntax:** [ *label* ] CALL *k*

**Operands:**  $0 \leq k \leq 2047$

**Operation:** (PC)+ 1 → TOS,  
 $k \rightarrow PC<10:0>$ ,  
(PCLATH<6:3>) → PC<14:11>

**Status Affected:** None

**Description:** Call Subroutine. First, return address (PC + 1) is pushed onto the stack. The 11-bit immediate address is loaded into PC bits <10:0>. The upper bits of the PC are loaded from PCLATH. CALL is a 2-cycle instruction.

## CLRWDT Clear Watchdog Timer

**Syntax:** [ *label* ] CLRWDT

**Operands:** None

**Operation:** 00h → WDT  
0 → WDT prescaler,  
1 →  $\overline{TO}$   
1 →  $\overline{PD}$

**Status Affected:**  $\overline{TO}$ ,  $\overline{PD}$

**Description:** CLRWDT instruction resets the Watchdog Timer. It also resets the prescaler of the WDT. Status bits  $\overline{TO}$  and  $\overline{PD}$  are set.

## CALLW Subroutine Call With W

**Syntax:** [ *label* ] CALLW

**Operands:** None

**Operation:** (PC) + 1 → TOS,  
(W) → PC<7:0>,  
(PCLATH<6:0>) → PC<14:8>

**Status Affected:** None

**Description:** Subroutine call with W. First, the return address (PC + 1) is pushed onto the return stack. Then, the contents of W is loaded into PC<7:0>, and the contents of PCLATH into PC<14:8>. CALLW is a 2-cycle instruction.

## COMF Complement f

**Syntax:** [ *label* ] COMF *f*,*d*

**Operands:**  $0 \leq f \leq 127$   
 $d \in [0,1]$

**Operation:** ( $\bar{f}$ ) → (destination)

**Status Affected:** Z

**Description:** The contents of register 'f' are complemented. If 'd' is '0', the result is stored in W. If 'd' is '1', the result is stored back in register 'f'.

## CLRF Clear f

**Syntax:** [ *label* ] CLRF *f*

**Operands:**  $0 \leq f \leq 127$

**Operation:** 00h → (f)  
1 → Z

**Status Affected:** Z

**Description:** The contents of register 'f' are cleared and the Z bit is set.

## DECF Decrement f

**Syntax:** [ *label* ] DECF *f*,*d*

**Operands:**  $0 \leq f \leq 127$   
 $d \in [0,1]$

**Operation:** (f) - 1 → (destination)

**Status Affected:** Z

**Description:** Decrement register 'f'. If 'd' is '0', the result is stored in the W register. If 'd' is '1', the result is stored back in register 'f'.

## CLRW Clear W

**Syntax:** [ *label* ] CLRW

**Operands:** None

**Operation:** 00h → (W)  
1 → Z

**Status Affected:** Z

**Description:** W register is cleared. Zero bit (Z) is set.

# PIC16(L)F1717/8/9

---

## **DECFSZ**      **Decrement f, Skip if 0**

---

Syntax:            [ *label* ] DECFSZ f,d

Operands:         $0 \leq f \leq 127$   
                     $d \in [0,1]$

Operation:         $(f) - 1 \rightarrow (\text{destination})$ ;  
                    skip if result = 0

Status Affected:    None

Description:      The contents of register 'f' are decremented. If 'd' is '0', the result is placed in the W register. If 'd' is '1', the result is placed back in register 'f'. If the result is '1', the next instruction is executed. If the result is '0', then a NOP is executed instead, making it a 2-cycle instruction.

## **INCFSZ**      **Increment f, Skip if 0**

---

Syntax:            [ *label* ] INCFSZ f,d

Operands:         $0 \leq f \leq 127$   
                     $d \in [0,1]$

Operation:         $(f) + 1 \rightarrow (\text{destination})$ ,  
                    skip if result = 0

Status Affected:    None

Description:      The contents of register 'f' are incremented. If 'd' is '0', the result is placed in the W register. If 'd' is '1', the result is placed back in register 'f'. If the result is '1', the next instruction is executed. If the result is '0', a NOP is executed instead, making it a 2-cycle instruction.

## **GOTO**          **Unconditional Branch**

---

Syntax:            [ *label* ] GOTO k

Operands:         $0 \leq k \leq 2047$

Operation:         $k \rightarrow \text{PC}<10:0>$   
                     $\text{PCLATH}<6:3> \rightarrow \text{PC}<14:11>$

Status Affected:    None

Description:      GOTO is an unconditional branch. The 11-bit immediate value is loaded into PC bits <10:0>. The upper bits of PC are loaded from PCLATH<4:3>. GOTO is a 2-cycle instruction.

## **IORLW**        **Inclusive OR literal with W**

---

Syntax:            [ *label* ] IORLW k

Operands:         $0 \leq k \leq 255$

Operation:         $(W) .\text{OR. } k \rightarrow (W)$

Status Affected:    Z

Description:      The contents of the W register are OR'ed with the 8-bit literal 'k'. The result is placed in the W register.

## **INCF**          **Increment f**

---

Syntax:            [ *label* ] INCF f,d

Operands:         $0 \leq f \leq 127$   
                     $d \in [0,1]$

Operation:         $(f) + 1 \rightarrow (\text{destination})$

Status Affected:    Z

Description:      The contents of register 'f' are incremented. If 'd' is '0', the result is placed in the W register. If 'd' is '1', the result is placed back in register 'f'.

## **IORWF**        **Inclusive OR W with f**

---

Syntax:            [ *label* ] IORWF f,d

Operands:         $0 \leq f \leq 127$   
                     $d \in [0,1]$

Operation:         $(W) .\text{OR. } (f) \rightarrow (\text{destination})$

Status Affected:    Z

Description:      Inclusive OR the W register with register 'f'. If 'd' is '0', the result is placed in the W register. If 'd' is '1', the result is placed back in register 'f'.

## LSLF Logical Left Shift

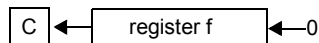
**Syntax:** `[label] LSLF f{,d}`

**Operands:**  $0 \leq f \leq 127$   
 $d \in [0,1]$

**Operation:**  $(f<7>) \rightarrow C$   
 $(f<6:0>) \rightarrow \text{dest}<7:1>$   
 $0 \rightarrow \text{dest}<0>$

**Status Affected:** C, Z

**Description:** The contents of register 'f' are shifted one bit to the left through the Carry flag. A '0' is shifted into the LSb. If 'd' is '0', the result is placed in W. If 'd' is '1', the result is stored back in register 'f'.



## MOVF Move f

**Syntax:** `[label] MOVF f,d`

**Operands:**  $0 \leq f \leq 127$   
 $d \in [0,1]$

**Operation:**  $(f) \rightarrow (\text{dest})$

**Status Affected:** Z

**Description:** The contents of register f is moved to a destination dependent upon the status of d. If  $d = 0$ , destination is W register. If  $d = 1$ , the destination is file register f itself.  $d = 1$  is useful to test a file register since status flag Z is affected.

**Words:** 1

**Cycles:** 1

**Example:** `MOVF FSR, 0`

After Instruction

W = value in FSR register

Z = 1

## LSRF Logical Right Shift

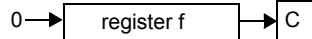
**Syntax:** `[label] LSRF f{,d}`

**Operands:**  $0 \leq f \leq 127$   
 $d \in [0,1]$

**Operation:**  $0 \rightarrow \text{dest}<7>$   
 $(f<7:1>) \rightarrow \text{dest}<6:0>$ ,  
 $(f<0>) \rightarrow C$ ,

**Status Affected:** C, Z

**Description:** The contents of register 'f' are shifted one bit to the right through the Carry flag. A '0' is shifted into the MSb. If 'd' is '0', the result is placed in W. If 'd' is '1', the result is stored back in register 'f'.



# PIC16(L)F1717/8/9

## MOVIW Move INDFn to W

Syntax: [ *label* ] MOVIW ++FSRn  
 [ *label* ] MOVIW --FSRn  
 [ *label* ] MOVIW FSRn++  
 [ *label* ] MOVIW FSRn--  
 [ *label* ] MOVIW k[FSRn]

Operands:  $n \in [0,1]$   
 $mm \in [00,01, 10, 11]$   
 $-32 \leq k \leq 31$

Operation: INDFn  $\rightarrow$  W  
 Effective address is determined by

- FSR + 1 (preincrement)
- FSR - 1 (predecrement)
- FSR + k (relative offset)

After the Move, the FSR value will be either:

- FSR + 1 (all increments)
- FSR - 1 (all decrements)
- Unchanged

Status Affected: Z

Mode	Syntax	mm
Preincrement	++FSRn	00
Predecrement	--FSRn	01
Postincrement	FSRn++	10
Postdecrement	FSRn--	11

Description: This instruction is used to move data between W and one of the indirect registers (INDFn). Before/after this move, the pointer (FSRn) is updated by pre/post incrementing/decrementing it.

**Note:** The INDFn registers are not physical registers. Any instruction that accesses an INDFn register actually accesses the register at the address specified by the FSRn.

FSRn is limited to the range 0000h - FFFFh. Incrementing/decrementing it beyond these bounds will cause it to wrap-around.

## MOVLB Move literal to BSR

Syntax: [ *label* ] MOVLB k

Operands:  $0 \leq k \leq 31$

Operation:  $k \rightarrow$  BSR

Status Affected: None

Description: The 5-bit literal 'k' is loaded into the Bank Select Register (BSR).

## MOVLP Move literal to PCLATH

Syntax: [ *label* ] MOVLP k

Operands:  $0 \leq k \leq 127$

Operation:  $k \rightarrow$  PCLATH

Status Affected: None

Description: The 7-bit literal 'k' is loaded into the PCLATH register.

## MOVLW Move literal to W

Syntax: [ *label* ] MOVLW k

Operands:  $0 \leq k \leq 255$

Operation:  $k \rightarrow$  (W)

Status Affected: None

Description: The 8-bit literal 'k' is loaded into W register. The "don't cares" will assemble as '0's.

Words: 1

Cycles: 1

**Example:** MOV LW 0x5A  
 After Instruction  
 W = 0x5A

## MOVWF Move W to f

Syntax: [ *label* ] MOVWF f

Operands:  $0 \leq f \leq 127$

Operation: (W)  $\rightarrow$  (f)

Status Affected: None

Description: Move data from W register to register 'f'.

Words: 1

Cycles: 1

**Example:** MOVWF OPTION\_REG  
 Before Instruction  
 OPTION\_REG = 0xFF  
 W = 0x4F  
 After Instruction  
 OPTION\_REG = 0x4F  
 W = 0x4F



MOVWI	Move W to INDFn
Syntax:	[ <i>label</i> ] MOVWI ++FSRn [ <i>label</i> ] MOVWI --FSRn [ <i>label</i> ] MOVWI FSRn++ [ <i>label</i> ] MOVWI FSRn-- [ <i>label</i> ] MOVWI k[FSRn]
Operands:	n ∈ [0,1] mm ∈ [00,01, 10, 11] -32 ≤ k ≤ 31
Operation:	W → INDFn Effective address is determined by <ul style="list-style-type: none"> <li>• FSR + 1 (preincrement)</li> <li>• FSR - 1 (predecrement)</li> <li>• FSR + k (relative offset)</li> </ul> After the Move, the FSR value will be either: <ul style="list-style-type: none"> <li>• FSR + 1 (all increments)</li> <li>• FSR - 1 (all decrements)</li> </ul> Unchanged
Status Affected:	None

Mode	Syntax	mm
Preincrement	++FSRn	00
Predecrement	--FSRn	01
Postincrement	FSRn++	10
Postdecrement	FSRn--	11

**Description:** This instruction is used to move data between W and one of the indirect registers (INDFn). Before/after this move, the pointer (FSRn) is updated by pre/post incrementing/decrementing it.

**Note:** The INDFn registers are not physical registers. Any instruction that accesses an INDFn register actually accesses the register at the address specified by the FSRn.

FSRn is limited to the range 0000h-FFFFh. Incrementing/decrementing it beyond these bounds will cause it to wrap-around.

The increment/decrement operation on FSRn WILL NOT affect any Status bits.

NOP	No Operation
Syntax:	[ <i>label</i> ] NOP
Operands:	None
Operation:	No operation
Status Affected:	None
Description:	No operation
Words:	1
Cycles:	1
<u>Example:</u>	NOP

OPTION	Load OPTION_REG Register with W
Syntax:	[ <i>label</i> ] OPTION
Operands:	None
Operation:	(W) → OPTION_REG
Status Affected:	None
Description:	Move data from W register to OPTION_REG register.
Words:	1
Cycles:	1
<u>Example:</u>	OPTION Before Instruction OPTION_REG = 0xFF W = 0x4F After Instruction OPTION_REG = 0x4F W = 0x4F

RESET	Software Reset
Syntax:	[ <i>label</i> ] RESET
Operands:	None
Operation:	Execute a device Reset. Resets the $\overline{RI}$ flag of the PCON register.
Status Affected:	None
Description:	This instruction provides a way to execute a hardware Reset by software.

# PIC16(L)F1717/8/9

**RETFIE**      **Return from Interrupt**

---

Syntax:      [ *label* ] RETFIE *k*

Operands:    None

Operation:    TOS → PC,  
                  1 → GIE

Status Affected:    None

Description:    Return from Interrupt. Stack is POPed and Top-of-Stack (TOS) is loaded in the PC. Interrupts are enabled by setting Global Interrupt Enable bit, GIE (INTCON<7>). This is a 2-cycle instruction.

Words:        1

Cycles:        2

Example:      RETFIE

                  After Interrupt

                  PC = TOS

                  GIE = 1

**RETURN**      **Return from Subroutine**

---

Syntax:      [ *label* ] RETURN

Operands:    None

Operation:    TOS → PC

Status Affected:    None

Description:    Return from subroutine. The stack is POPed and the top of the stack (TOS) is loaded into the program counter. This is a 2-cycle instruction.

**RETLW**      **Return with literal in W**

---

Syntax:      [ *label* ] RETLW *k*

Operands:     $0 \leq k \leq 255$

Operation:    *k* → (W);  
                  TOS → PC

Status Affected:    None

Description:    The W register is loaded with the 8-bit literal 'k'. The program counter is loaded from the top of the stack (the return address). This is a 2-cycle instruction.

Words:        1

Cycles:        2

Example:      CALL TABLE;W contains table  
                                  ;offset value

                  •    ;W now has table value

                  •

TABLE           •

                  ADDWF PC ;W = offset

                  RETLW *k1* ;Begin table

                  RETLW *k2* ;

                  •

                  •

                  •

                  RETLW *kn* ; End of table

                  Before Instruction

                  W = 0x07

                  After Instruction

                  W = value of *k8*

**RLF**          **Rotate Left f through Carry**

---

Syntax:      [ *label* ] RLF *f,d*

Operands:     $0 \leq f \leq 127$   
                   $d \in [0,1]$

Operation:    See description below

Status Affected:    C

Description:    The contents of register 'f' are rotated one bit to the left through the Carry flag. If 'd' is '0', the result is placed in the W register. If 'd' is '1', the result is stored back in register 'f'.

```

graph LR
    C[Carry Flag] --> R[Register f]
    R --> C
  
```

Words:        1

Cycles:        1

Example:      RLF      REG1,0

                  Before Instruction

                  REG1 = 1110 0110

                  C = 0

                  After Instruction

                  REG1 = 1110 0110

                  W = 1100 1100

                  C = 1

## RRF Rotate Right f through Carry

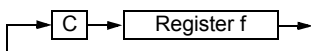
**Syntax:** [ *label* ] RRF f,d

**Operands:**  $0 \leq f \leq 127$   
 $d \in [0,1]$

**Operation:** See description below

**Status Affected:** C

**Description:** The contents of register 'f' are rotated one bit to the right through the Carry flag. If 'd' is '0', the result is placed in the W register. If 'd' is '1', the result is placed back in register 'f'.



## SUBLW Subtract W from literal

**Syntax:** [ *label* ] SUBLW k

**Operands:**  $0 \leq k \leq 255$

**Operation:**  $k - (W) \rightarrow (W)$

**Status Affected:** C, DC, Z

**Description:** The W register is subtracted (2's complement method) from the 8-bit literal 'k'. The result is placed in the W register.

C = 0	$W > k$
C = 1	$W \leq k$
DC = 0	$W\langle 3:0 \rangle > k\langle 3:0 \rangle$
DC = 1	$W\langle 3:0 \rangle \leq k\langle 3:0 \rangle$

## SLEEP Enter Sleep mode

**Syntax:** [ *label* ] SLEEP

**Operands:** None

**Operation:** 00h  $\rightarrow$  WDT,  
 0  $\rightarrow$  WDT prescaler,  
 1  $\rightarrow$   $\overline{TO}$ ,  
 0  $\rightarrow$   $\overline{PD}$

**Status Affected:**  $\overline{TO}$ ,  $\overline{PD}$

**Description:** The power-down Status bit,  $\overline{PD}$  is cleared. Time-out Status bit,  $\overline{TO}$  is set. Watchdog Timer and its prescaler are cleared. The processor is put into Sleep mode with the oscillator stopped.

## SUBWF Subtract W from f

**Syntax:** [ *label* ] SUBWF f,d

**Operands:**  $0 \leq f \leq 127$   
 $d \in [0,1]$

**Operation:**  $(f) - (W) \rightarrow (\text{destination})$

**Status Affected:** C, DC, Z

**Description:** Subtract (2's complement method) W register from register 'f'. If 'd' is '0', the result is stored in the W register. If 'd' is '1', the result is stored back in register 'f'.

C = 0	$W > f$
C = 1	$W \leq f$
DC = 0	$W\langle 3:0 \rangle > f\langle 3:0 \rangle$
DC = 1	$W\langle 3:0 \rangle \leq f\langle 3:0 \rangle$

## SUBWFB Subtract W from f with Borrow

**Syntax:** SUBWFB f {,d}

**Operands:**  $0 \leq f \leq 127$   
 $d \in [0,1]$

**Operation:**  $(f) - (W) - (\overline{B}) \rightarrow \text{dest}$

**Status Affected:** C, DC, Z

**Description:** Subtract W and the BORROW flag (CARRY) from register 'f' (2's complement method). If 'd' is '0', the result is stored in W. If 'd' is '1', the result is stored back in register 'f'.

# PIC16(L)F1717/8/9

---

## **SWAPF**      **Swap Nibbles in f**

---

Syntax:            [ *label* ] SWAPF f,d

Operands:         $0 \leq f \leq 127$   
                     $d \in [0,1]$

Operation:        ( $f<3:0>$ )  $\rightarrow$  (destination $<7:4>$ ),  
                    ( $f<7:4>$ )  $\rightarrow$  (destination $<3:0>$ )

Status Affected:    None

Description:      The upper and lower nibbles of register 'f' are exchanged. If 'd' is '0', the result is placed in the W register. If 'd' is '1', the result is placed in register 'f'.

## **XORLW**      **Exclusive OR literal with W**

---

Syntax:            [ *label* ] XORLW k

Operands:         $0 \leq k \leq 255$

Operation:        (W) .XOR. k  $\rightarrow$  (W)

Status Affected:    Z

Description:      The contents of the W register are XOR'ed with the 8-bit literal 'k'. The result is placed in the W register.

## **TRIS**          **Load TRIS Register with W**

---

Syntax:            [ *label* ] TRIS f

Operands:         $5 \leq f \leq 7$

Operation:        (W)  $\rightarrow$  TRIS register 'f'

Status Affected:    None

Description:      Move data from W register to TRIS register.  
                    When 'f' = 5, TRISA is loaded.  
                    When 'f' = 6, TRISB is loaded.  
                    When 'f' = 7, TRISC is loaded.

## **XORWF**      **Exclusive OR W with f**

---

Syntax:            [ *label* ] XORWF f,d

Operands:         $0 \leq f \leq 127$   
                     $d \in [0,1]$

Operation:        (W) .XOR. (f)  $\rightarrow$  (destination)

Status Affected:    Z

Description:      Exclusive OR the contents of the W register with register 'f'. If 'd' is '0', the result is stored in the W register. If 'd' is '1', the result is stored back in register 'f'.

## 34.0 ELECTRICAL SPECIFICATIONS

### 34.1 Absolute Maximum Ratings<sup>(†)</sup>

Ambient temperature under bias .....	-40°C to +125°C
Storage temperature .....	-65°C to +150°C
Voltage on pins with respect to V <sub>SS</sub>	
on V <sub>DD</sub> pin	
PIC16F1717/8/9 .....	-0.3V to +6.5V
PIC16LF1717/8/9 .....	-0.3V to +4.0V
on $\overline{\text{MCLR}}$ pin .....	-0.3V to +9.0V
on all other pins .....	-0.3V to (V <sub>DD</sub> + 0.3V)
Maximum current	
on V <sub>SS</sub> pin <sup>(1)</sup>	
-40°C ≤ T <sub>A</sub> ≤ +85°C .....	340 mA
-40°C ≤ T <sub>A</sub> ≤ +125°C .....	140 mA
on V <sub>DD</sub> pin <sup>(1)</sup> PIC16(L)F1718 only	
-40°C ≤ T <sub>A</sub> ≤ +85°C .....	250 mA
-40°C ≤ T <sub>A</sub> ≤ +125°C .....	85 mA
on V <sub>DD</sub> pin <sup>(1)</sup> PIC16(L)F1717/9 only	
-40°C ≤ T <sub>A</sub> ≤ +85°C .....	350 mA
-40°C ≤ T <sub>A</sub> ≤ +125°C .....	120 mA
Sunk by any standard I/O pin .....	50 mA
Sourced by any standard I/O pin .....	50 mA
Sourced by any Op Amp output pin .....	100 mA
Clamp current, I <sub>K</sub> (V <sub>PIN</sub> < 0 or V <sub>PIN</sub> > V <sub>DD</sub> ) .....	±20 mA
Total power dissipation <sup>(2)</sup> .....	800 mW

**Note 1:** Maximum current rating requires even load distribution across I/O pins. Maximum current rating may be limited by the device package power dissipation characterizations, see [Table 34-6](#) to calculate device specifications.

**2:** Power dissipation is calculated as follows:

$$P_{dis} = V_{DD} * \{I_{dd} - \sum I_{oh}\} + \sum \{V_{DD} - V_{oh}\} * I_{oh} + \sum \{V_{ol}\} * I_{ol}$$

† NOTICE: Stresses above those listed under “Absolute Maximum Ratings” may cause permanent damage to the device. This is a stress rating only and functional operation of the device at those or any other conditions above those indicated in the operation listings of this specification is not implied. Exposure above maximum rating conditions for extended periods may affect device reliability.

# PIC16(L)F1717/8/9

## 34.2 Standard Operating Conditions

The standard operating conditions for any device are defined as:

Operating Voltage:  $V_{DDMIN} \leq V_{DD} \leq V_{DDMAX}$

Operating Temperature:  $T_{A\_MIN} \leq T_A \leq T_{A\_MAX}$

### V<sub>DD</sub> — Operating Supply Voltage<sup>(1)</sup>

PIC16LF1717/8/9

V<sub>DDMIN</sub> (F<sub>osc</sub> ≤ 16 MHz)..... +1.8V

V<sub>DDMIN</sub> (F<sub>osc</sub> > 16 MHz)..... +2.5V

V<sub>DDMAX</sub> ..... +3.6V

PIC16F1717/8/9

V<sub>DDMIN</sub> (F<sub>osc</sub> ≤ 16 MHz)..... +2.3V

V<sub>DDMIN</sub> (> 16 MHz)..... +2.5V

V<sub>DDMAX</sub> ..... +5.5V

### T<sub>A</sub> — Operating Ambient Temperature Range

Industrial Temperature

T<sub>A\\_MIN</sub> ..... -40°C

T<sub>A\\_MAX</sub> ..... +85°C

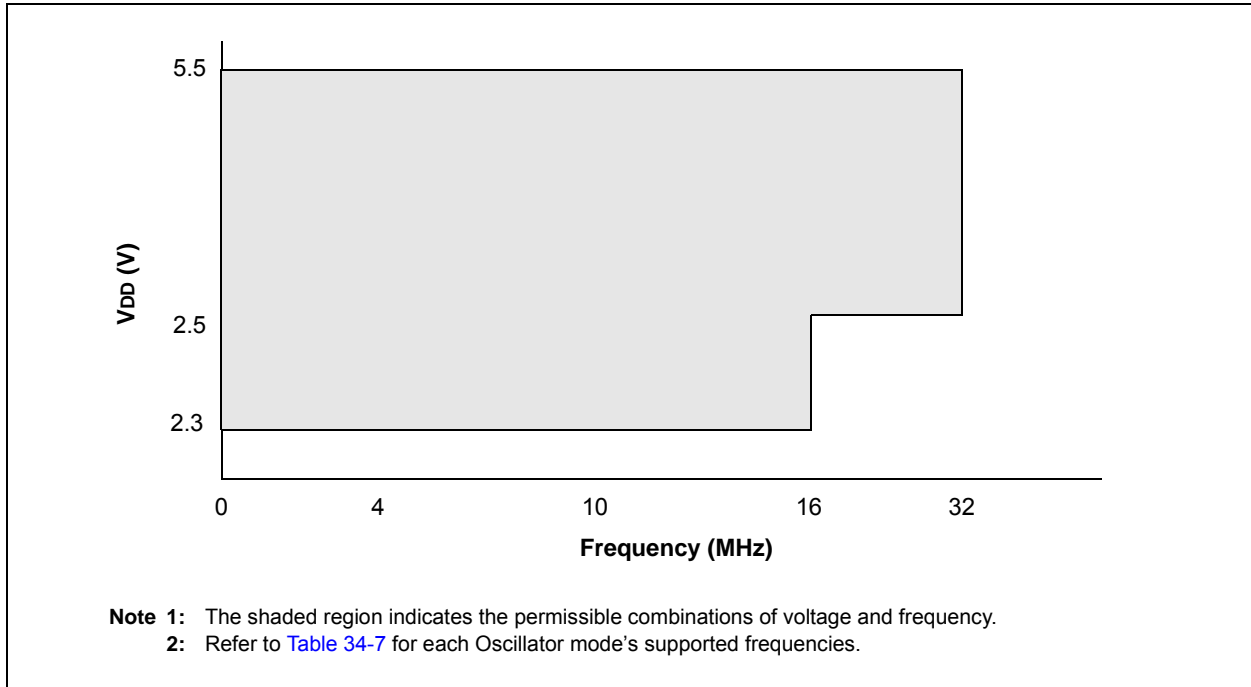
Extended Temperature

T<sub>A\\_MIN</sub> ..... -40°C

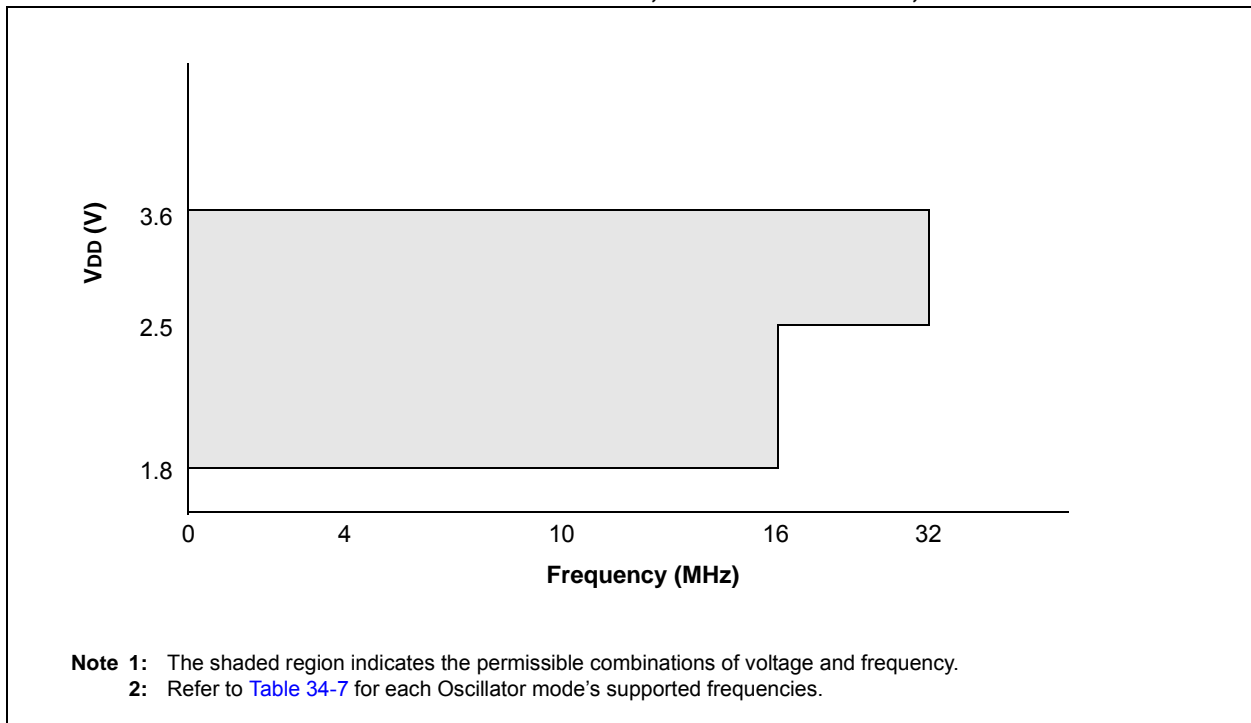
T<sub>A\\_MAX</sub> ..... +125°C

**Note 1:** See Parameter [D001](#), DS Characteristics: Supply Voltage.

**FIGURE 34-1: VOLTAGE FREQUENCY GRAPH,  $-40^{\circ}\text{C} \leq T_A \leq +125^{\circ}\text{C}$ , PIC16F1717/8/9 ONLY**



**FIGURE 34-2: VOLTAGE FREQUENCY GRAPH,  $-40^{\circ}\text{C} \leq T_A \leq +125^{\circ}\text{C}$ , PIC16LF1717/8/9 ONLY**



# PIC16(L)F1717/8/9

## 34.3 DC Characteristics

TABLE 34-1: SUPPLY VOLTAGE

PIC16LF1717/8/9		Standard Operating Conditions (unless otherwise stated)					
PIC16F1717/8/9							
Param. No.	Sym.	Characteristic	Min.	Typ.†	Max.	Units	Conditions
D001	VDD	<b>Supply Voltage</b>	VDDMIN	—	VDDMAX	V	FOSC ≤ 16 MHz FOSC > 32 MHz ( <b>Note 2</b> )
			1.8	—	3.6		
D001			2.5	—	3.6	V	
			2.3	—	5.5	V	FOSC ≤ 16 MHz
D002*	VDR	<b>RAM Data Retention Voltage<sup>(1)</sup></b>	2.5	—	5.5	V	FOSC > 32 MHz ( <b>Note 2</b> )
			1.5	—	—	V	Device in Sleep mode
D002*			1.7	—	—	V	Device in Sleep mode
D002A*	VPOR	<b>Power-on Reset Release Voltage<sup>(3)</sup></b>	—	1.6	—	V	
			—	1.6	—	V	
D002B*	VPORR*	<b>Power-on Reset Rearm Voltage<sup>(3)</sup></b>	—	0.8	—	V	
			—	1.5	—	V	
D003	VFVR	<b>Fixed Voltage Reference Voltage</b>	-4	—	+4	%	1x Gain, 1.024, VDD ≥ 2.5V, -40°C to 85°C
			-4	—	+4	%	2x Gain, 2.048, VDD ≥ 2.5V, -40°C to 85°C
			-5	—	+5	%	4x Gain, 4.096, VDD ≥ 4.75V, -40°C to 85°C
D004*	SVDD	<b>VDD Rise Rate<sup>(2)</sup></b>	0.05	—	—	V/ms	Ensures that the Power-on Reset signal is released properly.

\* These parameters are characterized but not tested.

† Data in "Typ" column is at 3.0V, 25°C unless otherwise stated. These parameters are for design guidance only and are not tested.

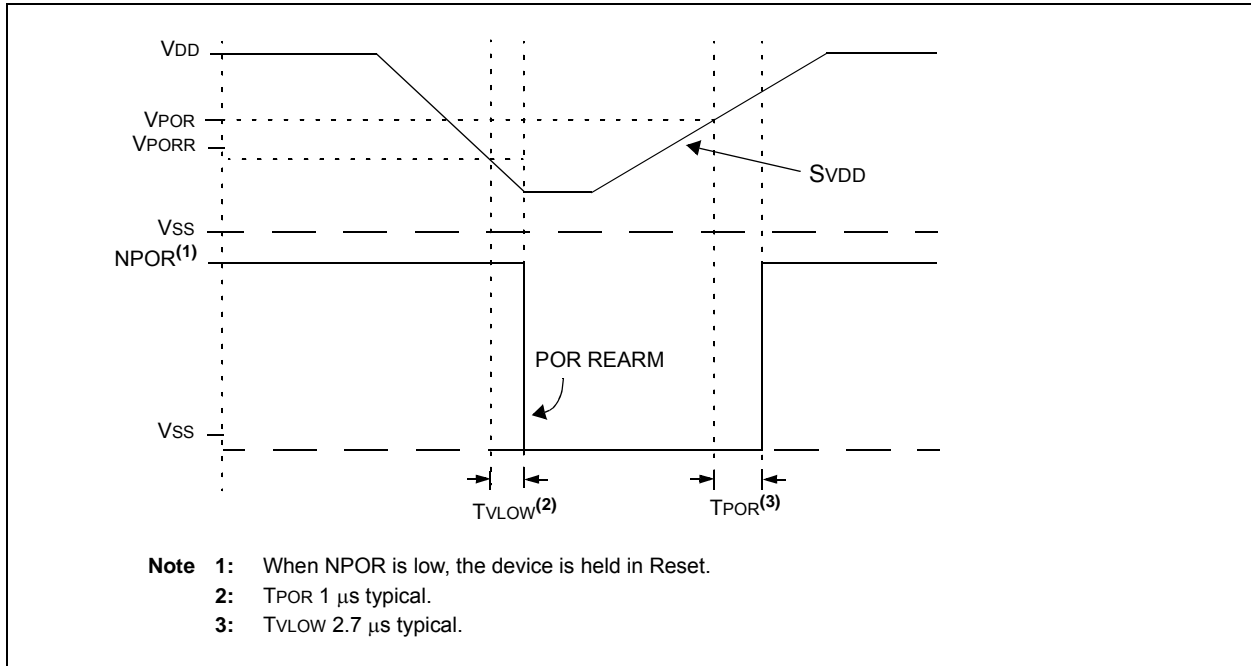
**Note 1:** This is the limit to which VDD can be lowered in Sleep mode without losing RAM data.

**Note 2:** PLL required for 32 MHz operation.

**Note 3:** See [Figure 34-3: POR and POR Rearm with Slow Rising VDD](#).



**FIGURE 34-3: POR AND POR REARM WITH SLOW RISING V<sub>DD</sub>**



# PIC16(L)F1717/8/9

**TABLE 34-2: SUPPLY CURRENT (IDD)<sup>(1,2)</sup>**

PIC16LF1717/8/9		Standard Operating Conditions (unless otherwise stated)					
PIC16F1717/8/9							
Param. No.	Device Characteristics	Min.	Typ.†	Max.	Units	Conditions	
						VDD	Note
D009	LDO Regulator	—	75	—	μA	—	High-Power mode, normal operation
		—	15	—	μA	—	Sleep, VREGCON<1> = 0
		—	0.3	—	μA	—	Sleep, VREGCON<1> = 1
D010		—	8	—	μA	1.8	Fosc = 32 kHz, LP Oscillator mode ( <b>Note 4</b> ), -40°C ≤ Ta ≤ +85°C
		—	12	—	μA	3.0	
D010		—	15	—	μA	2.3	Fosc = 32 kHz, LP Oscillator mode ( <b>Note 4, Note 5</b> ), -40°C ≤ Ta ≤ +85°C
		—	17	—	μA	3.0	
		—	21	—	μA	5.0	
D012		—	140	—	μA	1.8	Fosc = 4 MHz, XT Oscillator mode
		—	250	—	μA	3.0	
D012		—	210	—	μA	2.3	Fosc = 4 MHz, XT Oscillator mode ( <b>Note 5</b> )
		—	280	—	μA	3.0	
		—	340	—	μA	5.0	
D014		—	115	—	μA	1.8	Fosc = 4 MHz, External Clock (ECM), Medium Power mode
		—	210	—	μA	3.0	
D014		—	180	—	μA	2.3	Fosc = 4 MHz, External Clock (ECM), Medium Power mode ( <b>Note 5</b> )
		—	240	—	μA	3.0	
		—	300	—	μA	5.0	
D015		—	2.1	—	mA	3.0	Fosc = 32 MHz, External Clock (ECH), High-Power mode
		—	2.5	—	mA	3.6	
D015		—	2.1	—	mA	3.0	Fosc = 32 MHz, External Clock (ECH), High-Power mode ( <b>Note 5</b> )
		—	2.2	—	mA	5.0	

† Data in “Typ” column is at 3.0V, 25°C unless otherwise stated. These parameters are for design guidance only and are not tested.

- Note 1:** The test conditions for all IDD measurements in active operation mode are: OSC1 = external square wave, from rail-to-rail; all I/O pins tri-stated, pulled to VDD; MCLR = VDD; WDT disabled.
- 2:** The supply current is mainly a function of the operating voltage and frequency. Other factors, such as I/O pin loading and switching rate, oscillator type, internal code execution pattern and temperature, also have an impact on the current consumption.
- 3:** For RC oscillator configurations, current through REXT is not included. The current through the resistor can be extended by the formula  $IR = VDD/2REXT$  (mA) with REXT in kΩ
- 4:** FVR and BOR are disabled.
- 5:** 0.1 μF capacitor on VCAP.
- 6:** 8 MHz clock with 4x PLL enabled.

**TABLE 34-2: SUPPLY CURRENT (IDD)<sup>(1,2)</sup> (CONTINUED)**

PIC16LF1717/8/9		Standard Operating Conditions (unless otherwise stated)					
PIC16F1717/8/9							
Param. No.	Device Characteristics	Min.	Typ.†	Max.	Units	Conditions	
						VDD	Note
D017		—	130	—	μA	1.8	Fosc = 500 kHz, MFINTOSC mode
		—	150	—	μA	3.0	
D017		—	150	—	μA	2.3	Fosc = 500 kHz, MFINTOSC mode ( <b>Note 5</b> )
		—	170	—	μA	3.0	
		—	220	—	μA	5.0	
D019		—	0.8	—	mA	1.8	Fosc = 16 MHz, HFINTOSC mode
		—	1.2	—	mA	3.0	
D019		—	1.0	—	mA	2.3	Fosc = 16 MHz, HFINTOSC mode ( <b>Note 5</b> )
		—	1.3	—	mA	3.0	
		—	1.4	—	mA	5.0	
D020		—	2.1	—	mA	3.0	Fosc = 32 MHz, HFINTOSC mode
		—	2.5	—	mA	3.6	
D020		—	2.1	—	mA	3.0	Fosc = 32 MHz, HFINTOSC mode
		—	2.2	—	mA	5.0	
D022		—	2.1	—	mA	3.0	Fosc = 32 MHz, HS Oscillator mode ( <b>Note 6</b> )
		—	2.5	—	mA	3.6	
D022		—	2.1	—	mA	3.0	Fosc = 32 MHz HS Oscillator mode ( <b>Note 5, Note 6</b> )
		—	2.2	—	mA	5.0	

† Data in “Typ” column is at 3.0V, 25°C unless otherwise stated. These parameters are for design guidance only and are not tested.

- Note 1:** The test conditions for all IDD measurements in active operation mode are: OSC1 = external square wave, from rail-to-rail; all I/O pins tri-stated, pulled to VDD; MCLR = VDD; WDT disabled.
- 2:** The supply current is mainly a function of the operating voltage and frequency. Other factors, such as I/O pin loading and switching rate, oscillator type, internal code execution pattern and temperature, also have an impact on the current consumption.
- 3:** For RC oscillator configurations, current through REXT is not included. The current through the resistor can be extended by the formula  $IR = VDD/2REXT$  (mA) with REXT in kΩ.
- 4:** FVR and BOR are disabled.
- 5:** 0.1 μF capacitor on VCAP.
- 6:** 8 MHz clock with 4x PLL enabled.

# PIC16(L)F1717/8/9

**TABLE 34-3: POWER-DOWN CURRENTS (IPD)<sup>(1,2)</sup>**

PIC16LF1717/8/9		Standard Operating Conditions (unless otherwise stated) Low-Power Sleep Mode						
PIC16F1717/8/9		Low-Power Sleep Mode, VREGPM = 1						
Param. No.	Device Characteristics	Min.	Typ.†	Max. +85°C	Max. +125°C	Units	Conditions	
							VDD	Note
D023	Base IPD	—	0.05	1.0	8.0	μA	1.8	WDT, BOR, FVR, and SOSC disabled, all Peripherals Inactive
		—	0.08	2.0	9.0	μA	3.0	
D023	Base IPD	—	0.3	3	11	μA	2.3	WDT, BOR, FVR, and SOSC disabled, all Peripherals Inactive, Low-Power Sleep mode
		—	0.4	4	12	μA	3.0	
		—	0.5	6	15	μA	5.0	
D023A	Base IPD	—	9.8	16	18	μA	2.3	WDT, BOR, FVR and SOSC disabled, all Peripherals inactive, Normal Power Sleep mode VREGPM = 0
		—	10.3	18	20	μA	3.0	
		—	11.5	21	26	μA	5.0	
D024		—	0.5	6	14	μA	1.8	WDT Current
		—	0.8	7	17	μA	3.0	
D024		—	0.8	6	15	μA	2.3	WDT Current
		—	0.9	7	20	μA	3.0	
		—	1.0	8	22	μA	5.0	
D025		—	15	28	30	μA	1.8	FVR Current
		—	18	30	33	μA	3.0	
D025		—	18	33	35	μA	2.3	FVR Current
		—	19	35	37	μA	3.0	
		—	20	37	39	μA	5.0	
D026		—	7.5	25	28	μA	3.0	BOR Current
D026		—	10	25	28	μA	3.0	BOR Current
		—	12	28	31	μA	5.0	
D027		—	0.5	4	10	μA	3.0	LPBOR Current
D027		—	0.8	6	14	μA	3.0	LPBOR Current
		—	1	8	17	μA	5.0	
D028		—	0.5	5	9	μA	1.8	SOSC Current
		—	0.8	8.5	12	μA	3.0	
D028		—	1.1	6	10	μA	2.3	SOSC Current
		—	1.3	8.5	20	μA	3.0	
		—	1.4	10	25	μA	5.0	

\* These parameters are characterized but not tested.

† Data in “Typ” column is at 3.0V, 25°C unless otherwise stated. These parameters are for design guidance only and are not tested.

- Note 1:** The peripheral current is the sum of the base IPD and the additional current consumed when this peripheral is enabled. The peripheral Δ current can be determined by subtracting the base IDD or IPD current from this limit. Max values should be used when calculating total current consumption.
- 2:** The power-down current in Sleep mode does not depend on the oscillator type. Power-down current is measured with the part in Sleep mode, with all I/O pins in high-impedance state and tied to VSS.
- 3:** ADC clock source is FRC.

**TABLE 34-3: POWER-DOWN CURRENTS (IPD)<sup>(1,2)</sup> (CONTINUED)**

PIC16LF1717/8/9		Standard Operating Conditions (unless otherwise stated) Low-Power Sleep Mode						
PIC16F1717/8/9		Low-Power Sleep Mode, VREGPM = 1						
Param. No.	Device Characteristics	Min.	Typ.†	Max. +85°C	Max. +125°C	Units	Conditions	
							VDD	Note
D029		—	0.05	2	9	μA	1.8	ADC Current ( <b>Note 3</b> ), no conversion in progress
		—	0.08	3	10	μA	3.0	
D029		—	0.3	4	12	μA	2.3	ADC Current ( <b>Note 3</b> ), no conversion in progress
		—	0.4	5	13	μA	3.0	
		—	0.5	7	16	μA	5.0	
D030		—	250	—	—	μA	1.8	ADC Current ( <b>Note 3</b> ), conversion in progress
		—	250	—	—	μA	3.0	
D030		—	280	—	—	μA	2.3	ADC Current ( <b>Note 3</b> ), conversion in progress
		—	280	—	—	μA	3.0	
		—	280	—	—	μA	5.0	
D031		—	250	650	—	μA	3.0	Op Amp (High power)
D031		—	250	650	—	μA	3.0	Op Amp (High power)
		—	350	650	—	μA	5.0	
D032		—	250	600	—	μA	1.8	Comparator, CxSP = 0
		—	300	650	—	μA	3.0	
D032		—	280	600	—	μA	2.3	Comparator, CxSP = 0 VREGPM = 0
		—	300	650	—	μA	3.0	
		—	310	650	—	μA	5.0	

\* These parameters are characterized but not tested.

† Data in “Typ” column is at 3.0V, 25°C unless otherwise stated. These parameters are for design guidance only and are not tested.

- Note 1:** The peripheral current is the sum of the base IPD and the additional current consumed when this peripheral is enabled. The peripheral Δ current can be determined by subtracting the base IDD or IPD current from this limit. Max values should be used when calculating total current consumption.
- 2:** The power-down current in Sleep mode does not depend on the oscillator type. Power-down current is measured with the part in Sleep mode, with all I/O pins in high-impedance state and tied to Vss.
- 3:** ADC clock source is FRC.

# PIC16(L)F1717/8/9

TABLE 34-4: I/O PORTS

Standard Operating Conditions (unless otherwise stated)								
Param. No.	Sym.	Characteristic	Min.	Typ.†	Max.	Units	Conditions	
D034 D034A D035 D036 D036A	V <sub>IL</sub>	<b>Input Low Voltage</b>						
		I/O PORT:						
		with TTL buffer	—	—	0.8	V	4.5V ≤ V <sub>DD</sub> ≤ 5.5V	
			—	—	0.15 V <sub>DD</sub>	V	1.8V ≤ V <sub>DD</sub> ≤ 4.5V	
		with Schmitt Trigger buffer	—	—	0.2 V <sub>DD</sub>	V	2.0V ≤ V <sub>DD</sub> ≤ 5.5V	
		with I <sup>2</sup> C levels	—	—	0.3 V <sub>DD</sub>	V		
		with SMBus levels	—	—	0.8	V	2.7V ≤ V <sub>DD</sub> ≤ 5.5V	
D036		MCLR, OSC1 (EXTRC mode)	—	—	0.2 V <sub>DD</sub>	V	(Note 1)	
D036A		OSC1 (HS mode)	—	—	0.3 V <sub>DD</sub>	V		
D040 D040A D041 D042 D043A D043B	V <sub>IH</sub>	<b>Input High Voltage</b>						
		I/O ports:						
		with TTL buffer	2.0	—	—	V	4.5V ≤ V <sub>DD</sub> ≤ 5.5V	
			0.25 V <sub>DD</sub> + 0.8	—	—	V	1.8V ≤ V <sub>DD</sub> ≤ 4.5V	
		with Schmitt Trigger buffer	0.8 V <sub>DD</sub>	—	—	V	2.0V ≤ V <sub>DD</sub> ≤ 5.5V	
		with I <sup>2</sup> C levels	0.7 V <sub>DD</sub>	—	—	V		
		with SMBus levels	2.1	—	—	V	2.7V ≤ V <sub>DD</sub> ≤ 5.5V	
		D042		MCLR	0.8 V <sub>DD</sub>	—	—	V
D043A		OSC1 (HS mode)	0.7 V <sub>DD</sub>	—	—	V		
D043B		OSC1 (EXTRC oscillator)	0.9 V <sub>DD</sub>	—	—	V	V <sub>DD</sub> > 2.0V (Note 1)	
D060  D061	I <sub>IL</sub>	<b>Input Leakage Current<sup>(2)</sup></b>						
		I/O Ports	—	± 5	± 125	nA	V <sub>SS</sub> ≤ V <sub>PIN</sub> ≤ V <sub>DD</sub> , Pin at high-impedance, 85°C	
			—	± 5	± 1000	nA	V <sub>SS</sub> ≤ V <sub>PIN</sub> ≤ V <sub>DD</sub> , Pin at high-impedance, 125°C	
D061		MCLR <sup>(3)</sup>	—	± 5	± 200	nA	V <sub>SS</sub> ≤ V <sub>PIN</sub> ≤ V <sub>DD</sub> , Pin at high-impedance, 85°C	

\* These parameters are characterized but not tested.

† Data in "Typ" column is at 3.0V, 25°C unless otherwise stated. These parameters are for design guidance only and are not tested.

**Note 1:** In EXTRC oscillator configuration, the OSC1/CLKIN pin is a Schmitt Trigger input. It is not recommended to use an external clock in EXTRC mode.

**2:** Negative current is defined as current sourced by the pin.

**3:** The leakage current on the MCLR pin is strongly dependent on the applied voltage level. The specified levels represent normal operating conditions. Higher leakage current may be measured at different input voltages.

**4:** Including OSC2 in CLKOUT mode.

**TABLE 34-4: I/O PORTS (CONTINUED)**

Standard Operating Conditions (unless otherwise stated)							
Param. No.	Sym.	Characteristic	Min.	Typ.†	Max.	Units	Conditions
D070*	IPUR	<b>Weak Pull-up Current</b>					
			25	100	200	μA	V <sub>DD</sub> = 3.3V, V <sub>PIN</sub> = V <sub>SS</sub>
			25	140	300	μA	V <sub>DD</sub> = 5.0V, V <sub>PIN</sub> = V <sub>SS</sub>
D080	VOL	<b>Output Low Voltage<sup>(4)</sup></b>					
		I/O ports	—	—	0.6	V	I <sub>OL</sub> = 8mA, V <sub>DD</sub> = 5V I <sub>OL</sub> = 6mA, V <sub>DD</sub> = 3.3V I <sub>OL</sub> = 1.8mA, V <sub>DD</sub> = 1.8V
D090	VOH	<b>Output High Voltage<sup>(4)</sup></b>					
		I/O ports	V <sub>DD</sub> - 0.7	—	—	V	I <sub>OH</sub> = 3.5mA, V <sub>DD</sub> = 5V I <sub>OH</sub> = 3mA, V <sub>DD</sub> = 3.3V I <sub>OH</sub> = 1mA, V <sub>DD</sub> = 1.8V
D101*	COSC2	<b>Capacitive Loading Specs on Output Pins</b>					
		OSC2 pin	—	—	15	pF	In XT, HS and LP modes when external clock is used to drive OSC1
D101A*	CIO	All I/O pins	—	—	50	pF	—

\* These parameters are characterized but not tested.

† Data in “Typ” column is at 3.0V, 25°C unless otherwise stated. These parameters are for design guidance only and are not tested.

**Note 1:** In EXTRC oscillator configuration, the OSC1/CLKIN pin is a Schmitt Trigger input. It is not recommended to use an external clock in EXTRC mode.

**2:** Negative current is defined as current sourced by the pin.

**3:** The leakage current on the  $\overline{\text{MCLR}}$  pin is strongly dependent on the applied voltage level. The specified levels represent normal operating conditions. Higher leakage current may be measured at different input voltages.

**4:** Including OSC2 in CLKOUT mode.

# PIC16(L)F1717/8/9

**TABLE 34-5: MEMORY PROGRAMMING SPECIFICATIONS**

Standard Operating Conditions (unless otherwise stated)							
Param. No.	Sym.	Characteristic	Min.	Typ.†	Max.	Units	Conditions
<b>Program Memory Programming Specifications</b>							
D110	VIHH	Voltage on MCLR/VPP pin	8.0	—	9.0	V	<b>(Note 2)</b>
D111	IDDP	Supply Current during Programming	—	—	10	mA	
D112	VBE	VDD for Bulk Erase	2.7	—	VDDMAX	V	
D113	VPEW	VDD for Write or Row Erase	VDDMIN	—	VDDMAX	V	
D114	IPPGM	Current on MCLR/VPP during Erase/Write	—	1.0	—	mA	
D115	IDDPGM	Current on VDD during Erase/Write	—	5.0	—	mA	
<b>Program Flash Memory</b>							
D121	EP	Cell Endurance	10K	—	—	E/W	<b>(Note 1)</b> -40°C ≤ TA ≤ +85°C
D122	VPRW	VDD for Read/Write	VDDMIN	—	VDDMAX	V	
D123	TIW	Self-timed Write Cycle Time	—	2	2.5	ms	Provided no other specifications are violated
D124	TRETD	Characteristic Retention	—	40	—	Year	
D125	EHEFC	High-Endurance Flash Cell	100K	—	—	E/W	-0°C ≤ TA ≤ +60°C, Lower byte last 128 addresses

† Data in “Typ” column is at 3.0V, 25°C unless otherwise stated. These parameters are for design guidance only and are not tested.

**Note 1:** Self-write and Block Erase.

**2:** Required only if single-supply programming is disabled.



**TABLE 34-6: THERMAL CHARACTERISTICS**

**Standard Operating Conditions** (unless otherwise stated)

Param. No.	Sym.	Characteristic	Typ.	Units	Conditions
TH01	θJA	Thermal Resistance Junction to Ambient	60.0	°C/W	28-pin SPDIP package
			80.3	°C/W	28-pin SOIC package
			90.0	°C/W	28-pin SSOP package
			36.0	°C/W	28-pin QFN 6x6 mm package
			48.0	°C/W	28-pin UQFN 4x4 mm package
			47.2	°C/W	40-pin PDIP package
			46.0	°C/W	44-pin TQFP
			41.0	°C/W	40-pin UQFN 5x5 mm package
TH02	θJC	Thermal Resistance Junction to Case	31.4	°C/W	28-pin SPDIP package
			24.0	°C/W	28-pin SOIC package
			24.0	°C/W	28-pin SSOP package
			6.0	°C/W	28-pin QFN 6x6 mm package
			12.0	°C/W	28-pin UQFN 4x4 mm package
			24.7	°C/W	40-pin PDIP package
			14.5	°C/W	44-pin TQFP
			50.5	°C/W	40-pin UQFN 5x5 mm package
TH03	TJMAX	Maximum Junction Temperature	150	°C	—
TH04	PD	Power Dissipation	—	W	PD = PINTERNAL + PI/O
TH05	PINTERNAL	Internal Power Dissipation	—	W	PINTERNAL = IDD x VDD <sup>(1)</sup>
TH06	PI/O	I/O Power Dissipation	—	W	PI/O = Σ (IOL * VOL) + Σ (IOH * (VDD - VOH))
TH07	PDER	Derated Power	—	W	PDER = PDMAX (TJ - TA)/θJA <sup>(2)</sup>

**Note 1:** IDD is current to run the chip alone without driving any load on the output pins.

**2:** TA = Ambient Temperature, TJ = Junction Temperature

# PIC16(L)F1717/8/9

## 34.4 AC Characteristics

Timing Parameter Symbolism has been created with one of the following formats:

1. TppS2ppS
2. TppS

<b>T</b>			
F	Frequency	T	Time

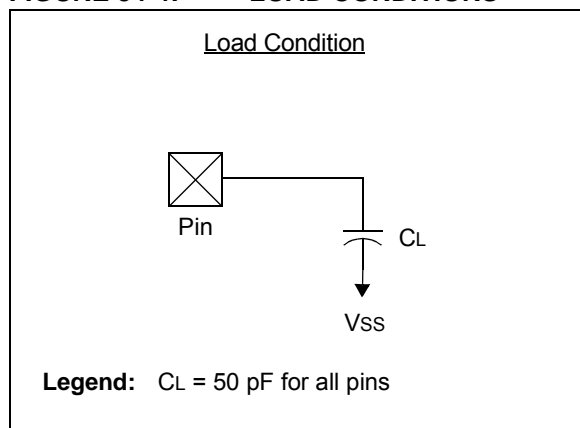
Lowercase letters (pp) and their meanings:

<b>pp</b>			
cc	CCP1	osc	OSC1
ck	CLKOUT	rd	$\overline{RD}$
cs	$\overline{CS}$	rw	$\overline{RD}$ or $\overline{WR}$
di	SDI	sc	SCK
do	SDO	ss	$\overline{SS}$
dt	Data in	t0	T0CKI
io	I/O PORT	t1	T1CKI
mc	$\overline{MCLR}$	wr	$\overline{WR}$

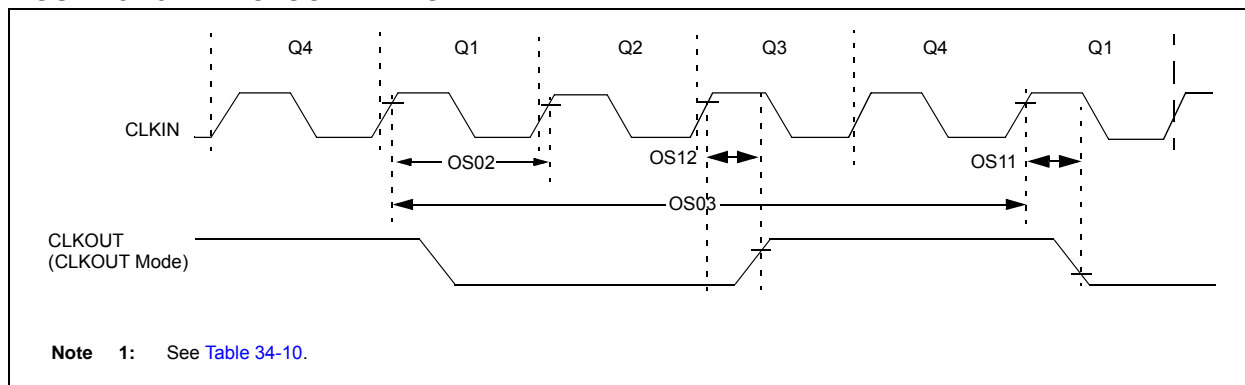
Uppercase letters and their meanings:

<b>S</b>			
F	Fall	P	Period
H	High	R	Rise
I	Invalid (High-impedance)	V	Valid
L	Low	Z	High-impedance

**FIGURE 34-4: LOAD CONDITIONS**



**FIGURE 34-5: CLOCK TIMING**



**TABLE 34-7: CLOCK OSCILLATOR TIMING REQUIREMENTS**

**Standard Operating Conditions** (unless otherwise stated)

Param. No.	Sym.	Characteristic	Min.	Typ.†	Max.	Units	Conditions
OS01	Fosc	External CLKIN Frequency <sup>(1)</sup>	DC	—	0.5	MHz	External Clock (ECL)
			DC	—	4	MHz	External Clock (ECM)
			DC	—	20	MHz	External Clock (ECH)
		Oscillator Frequency <sup>(1)</sup>	—	32.768	—	kHz	LP Oscillator
			0.1	—	4	MHz	XT Oscillator
1	—		4	MHz	HS Oscillator		
1	—		20	MHz	HS Oscillator, V <sub>DD</sub> > 2.7V		
DC	—	4	MHz	EXTRC, V <sub>DD</sub> > 2.0V			
OS02	Tosc	External CLKIN Period <sup>(1)</sup>	27	—	∞	μs	LP Oscillator
			250	—	∞	ns	XT Oscillator
			50	—	∞	ns	HS Oscillator
			50	—	∞	ns	External Clock (EC)
		Oscillator Period <sup>(1)</sup>	—	30.5	—	μs	LP Oscillator
250	—	10,000	ns	XT Oscillator			
50	—	1,000	ns	HS Oscillator			
250	—	ns	EXTRC				
OS03	Tcy	Instruction Cycle Time <sup>(1)</sup>	125	Tcy	DC	ns	Tcy = 4/Fosc
OS04*	TosH, TosL	External CLKIN High, External CLKIN Low	2	—	—	μs	LP Oscillator
			100	—	—	ns	XT Oscillator
			20	—	—	ns	HS Oscillator
OS05*	TosR, TosF	External CLKIN Rise, External CLKIN Fall	0	—	∞	ns	LP Oscillator
			0	—	∞	ns	XT Oscillator
			0	—	∞	ns	HS Oscillator

\* These parameters are characterized but not tested.

† Data in “Typ” column is at 3.0V, 25°C unless otherwise stated. These parameters are for design guidance only and are not tested.

**Note 1:** Instruction cycle period (Tcy) equals four times the input oscillator time base period. All specified values are based on characterization data for that particular oscillator type under standard operating conditions with the device executing code. Exceeding these specified limits may result in an unstable oscillator operation and/or higher than expected current consumption. All devices are tested to operate at “min” values with an external clock applied to OSC1 pin. When an external clock input is used, the “max” cycle time limit is “DC” (no clock) for all devices.

# PIC16(L)F1717/8/9

**TABLE 34-8: OSCILLATOR PARAMETERS**

Standard Operating Conditions (unless otherwise stated)								
Param. No.	Sym.	Characteristic	Freq. Tolerance	Min.	Typ.†	Max.	Units	Conditions
OS08	HFosc	Internal Calibrated HFINTOSC Frequency <sup>(1)</sup>	±2%	—	16.0	—	MHz	V <sub>DD</sub> = 3.0V, T <sub>A</sub> = 25°C, (Note 2)
OS08A	MFosc	Internal Calibrated MFINTOSC Frequency <sup>(1)</sup>	±2%	—	500	—	kHz	V <sub>DD</sub> = 3.0V, T <sub>A</sub> = 25°C, (Note 2)
OS09	LFosc	Internal LFINTOSC Frequency	—	—	31	—	kHz	-40°C ≤ T <sub>A</sub> ≤ +125°C, (Note 3)
OS10*	TWARM	HFINTOSC Wake-up from Sleep Start-up Time	—	—	3.2	8	μs	
		MFINTOSC Wake-up from Sleep Start-up Time	—	—	24	35	μs	
		LFINTOSC Wake-up from Sleep Start-up Time	—	—	0.5	—	ms	

\* These parameters are characterized but not tested.

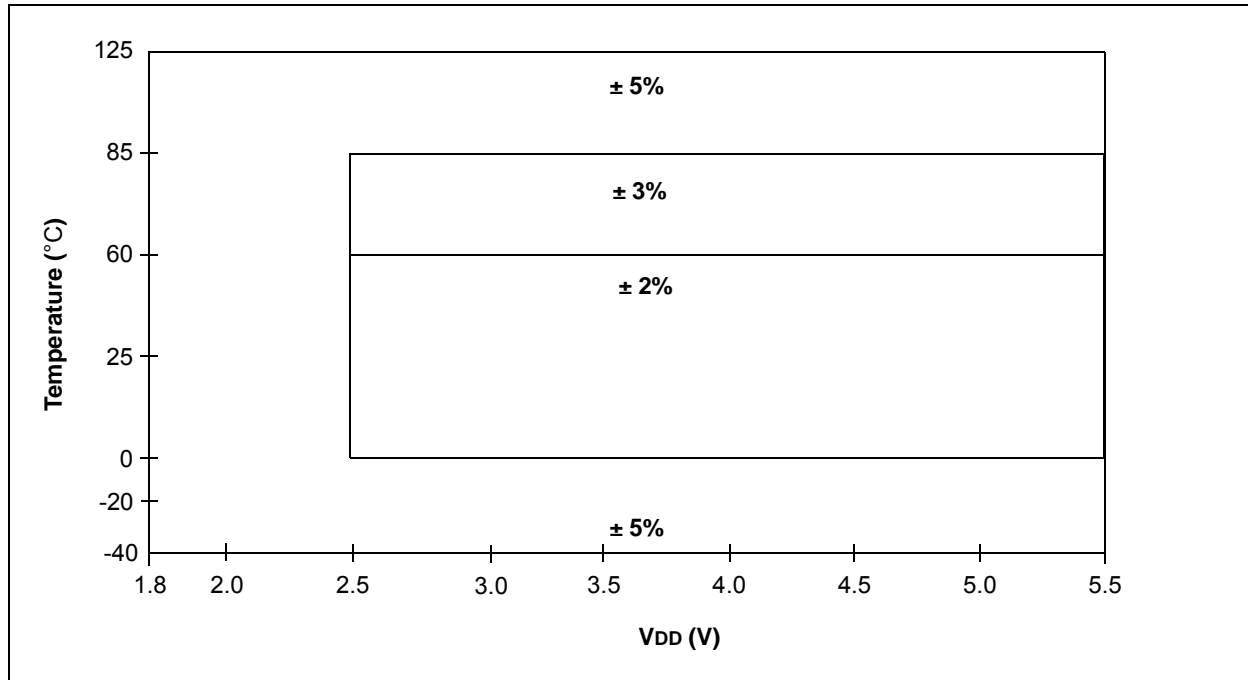
† Data in "Typ" column is at 3.0V, 25°C unless otherwise stated. These parameters are for design guidance only and are not tested.

**Note 1:** To ensure these oscillator frequency tolerances, V<sub>DD</sub> and V<sub>SS</sub> must be capacitively decoupled as close to the device as possible. 0.1 μF and 0.01 μF values in parallel are recommended.

2: See Figure 34-6.

3: See Figure 35-57: LFINTOSC Frequency, PIC16LF1717/8/9 Only., and Figure 35-58: LFINTOSC Frequency, PIC16F1717/8/9 Only..

**FIGURE 34-6: HFINTOSC FREQUENCY ACCURACY OVER DEVICE V<sub>DD</sub> AND TEMPERATURE**



**TABLE 34-9: PLL CLOCK TIMING SPECIFICATIONS**

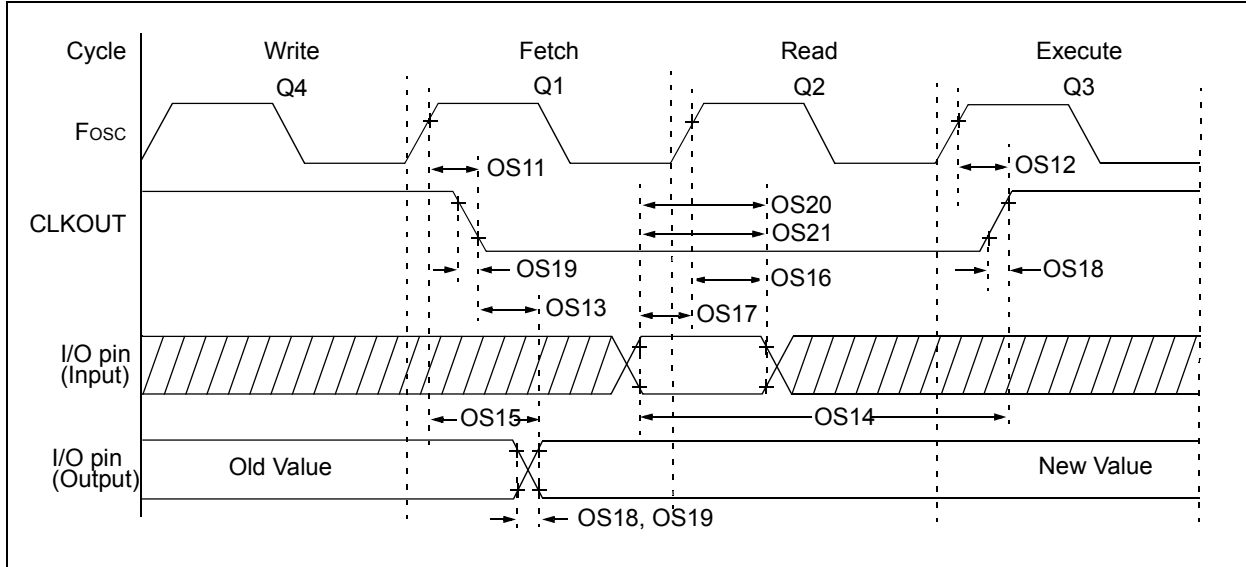
Standard Operating Conditions (unless otherwise stated)							
Param. No.	Sym.	Characteristic	Min.	Typ.†	Max.	Units	Conditions
F10	FOSC	Oscillator Frequency Range	4	—	8	MHz	
F11	FSYS	On-Chip VCO System Frequency	16	—	32	MHz	
F12	TRC	PLL Start-up Time (Lock Time)	—	—	2	ms	
F13*	ΔCLK	CLKOUT Stability (Jitter)	-0.25%	—	+0.25%	%	

\* These parameters are characterized but not tested.

† Data in “Typ” column is at 5V, 25°C unless otherwise stated. These parameters are for design guidance only and are not tested.

# PIC16(L)F1717/8/9

**FIGURE 34-7: CLKOUT AND I/O TIMING**



**TABLE 34-10: CLKOUT AND I/O TIMING PARAMETERS**

Standard Operating Conditions (unless otherwise stated)							
Param. No.	Sym.	Characteristic	Min.	Typ.†	Max.	Units	Conditions
OS11	TosH2ckL	Fosc↑ to CLKOUT↓ <sup>(1)</sup>	—	—	70	ns	3.3V ≤ VDD ≤ 5.0V
OS12	TosH2ckH	Fosc↑ to CLKOUT↑ <sup>(1)</sup>	—	—	72	ns	3.3V ≤ VDD ≤ 5.0V
OS13	TckL2ioV	CLKOUT↓ to Port out valid <sup>(1)</sup>	—	—	20	ns	
OS14	TioV2ckH	Port input valid before CLKOUT↑ <sup>(1)</sup>	Tosc + 200 ns	—	—	ns	
OS15	TosH2ioV	Fosc↑ (Q1 cycle) to Port out valid	—	50	70*	ns	3.3V ≤ VDD ≤ 5.0V
OS16	TosH2ioI	Fosc↑ (Q2 cycle) to Port input invalid (I/O in hold time)	50	—	—	ns	3.3V ≤ VDD ≤ 5.0V
OS17	TioV2osH	Port input valid to Fosc↑ (Q2 cycle) (I/O in setup time)	20	—	—	ns	
OS18*	TioR	Port output rise time <sup>(2)</sup>	—	40 15	72 32	ns	VDD = 1.8V 3.3V ≤ VDD ≤ 5.0V
OS19*	TioF	Port output fall time <sup>(2)</sup>	—	28 15	55 30	ns	VDD = 1.8V 3.3V ≤ VDD ≤ 5.0V
OS20*	TINP	INT pin input high or low time	25	—	—	ns	
OS21*	TIOC	Interrupt-on-Change new input level time	25	—	—	ns	

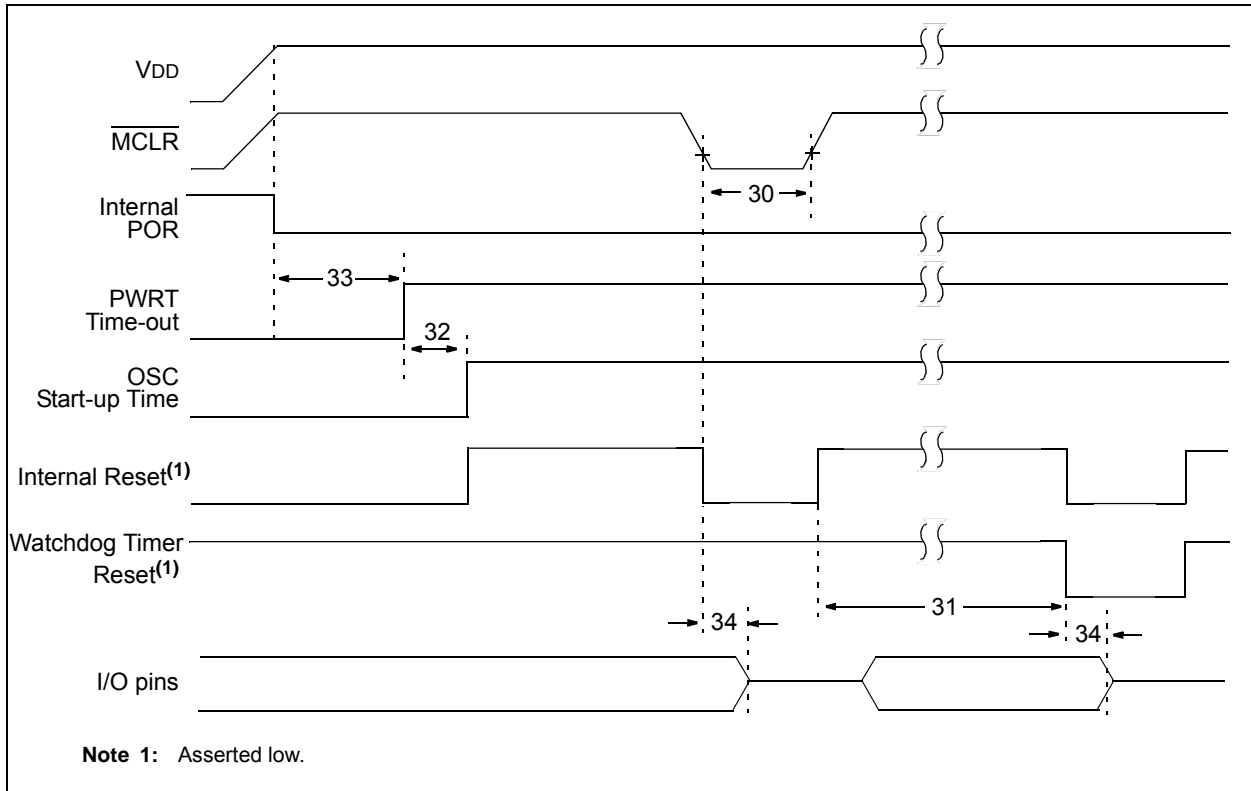
\* These parameters are characterized but not tested.

† Data in "Typ" column is at 3.0V, 25°C unless otherwise stated.

**Note 1:** Measurements are taken in EXTRC mode where CLKOUT output is 4 x Tosc.

**2:** Slew rate limited.

**FIGURE 34-8: RESET, WATCHDOG TIMER, OSCILLATOR START-UP TIMER AND POWER-UP TIMER TIMING**



# PIC16(L)F1717/8/9

**TABLE 34-11: RESET, WATCHDOG TIMER, OSCILLATOR START-UP TIMER, POWER-UP TIMER AND BROWN-OUT RESET PARAMETERS**

Standard Operating Conditions (unless otherwise stated) <sup>(2)</sup>							
Param. No.	Sym.	Characteristic	Min.	Typ†	Max.	Units	Conditions
30	TMCL	$\overline{\text{MCLR}}$ Pulse Width (low)	2	—	—	μs	
31	TWDTLP	Low-Power Watchdog Timer Time-out Period	10	16	27	ms	V <sub>DD</sub> = 3.3V-5V 1:16 Prescaler used
32	TOST	Oscillator Start-up Timer Period <sup>(1)</sup>	—	1024	—	T <sub>Osc</sub>	
33*	TPWRT	Power-up Timer Period, $\overline{\text{PWRTE}} = 0$	40	65	140	ms	
34*	TIOZ	I/O high-impedance from $\overline{\text{MCLR}}$ Low or Watchdog Timer Reset	—	—	2.0	μs	
35	VBOR	Brown-out Reset Voltage	2.55	2.70	2.85	V	BORV = 0
			2.30	2.45	2.60	V	BORV = 1 (PIC16F1717/8/9)
			1.80	1.90	2.10	V	BORV = 1 (PIC16LF1717/8/9)
35A	VLPBOR	Low-Power Brown-out	1.8	2.1	2.5	V	LPBOR = 1
36*	VHYST	Brown-out Reset Hysteresis	0	25	75	mV	-40°C ≤ T <sub>A</sub> ≤ +85°C
37*	TBORDC	Brown-out Reset DC Response Time	1	3	35	μs	V <sub>DD</sub> ≤ V <sub>BOR</sub>

\* These parameters are characterized but not tested.

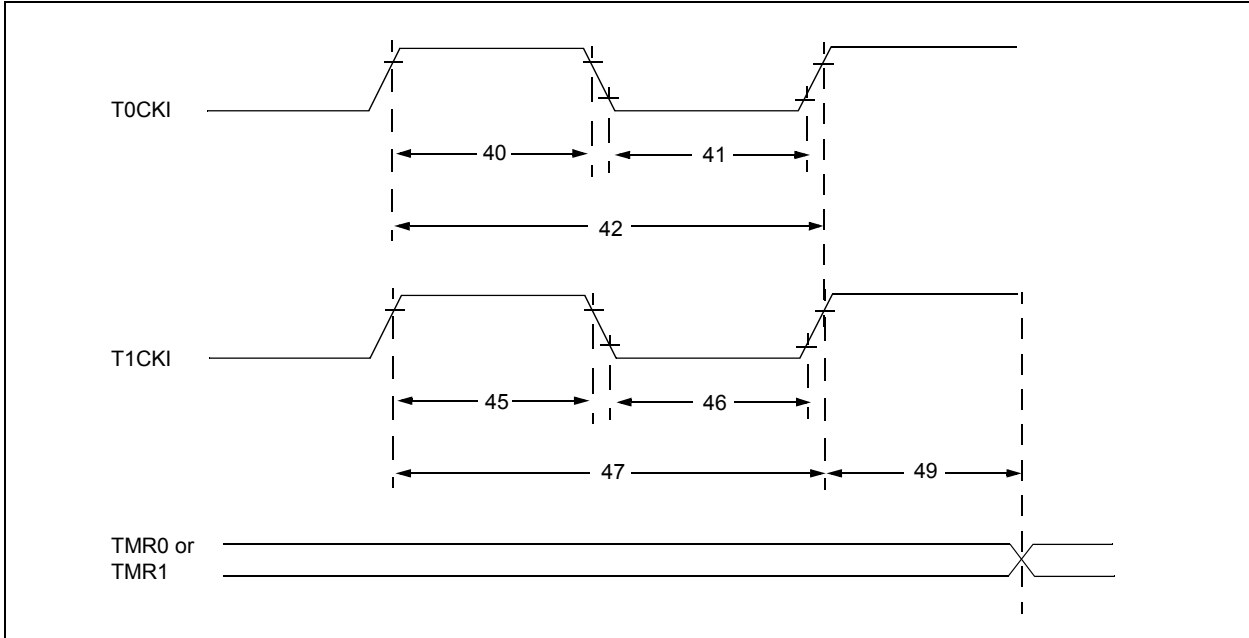
† Data in "Typ" column is at 3.0V, 25°C unless otherwise stated. These parameters are for design guidance only and are not tested.

**Note 1:** By design, the Oscillator Start-up Timer (OST) counts the first 1024 cycles, independent of frequency.

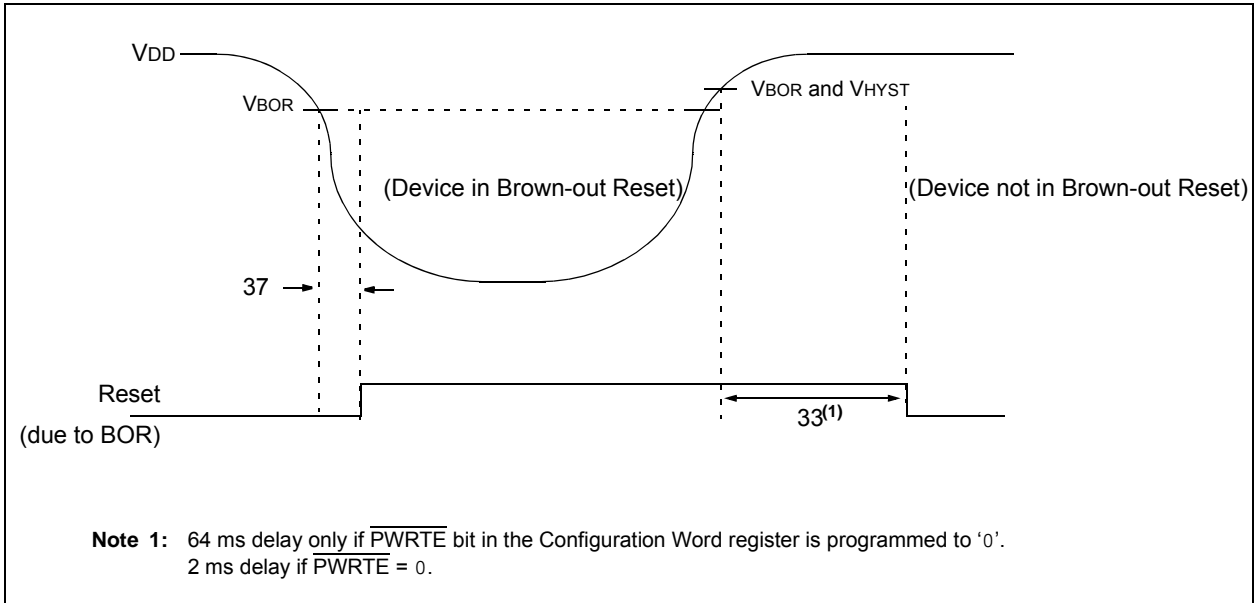
**Note 2:** To ensure these voltage tolerances, V<sub>DD</sub> and V<sub>SS</sub> must be capacitively decoupled as close to the device as possible. 0.1 μF and 0.01 μF values in parallel are recommended.



**FIGURE 34-9: TIMER0 AND TIMER1 EXTERNAL CLOCK TIMINGS**



**FIGURE 34-10: BROWN-OUT RESET TIMING AND CHARACTERISTICS**



# PIC16(L)F1717/8/9

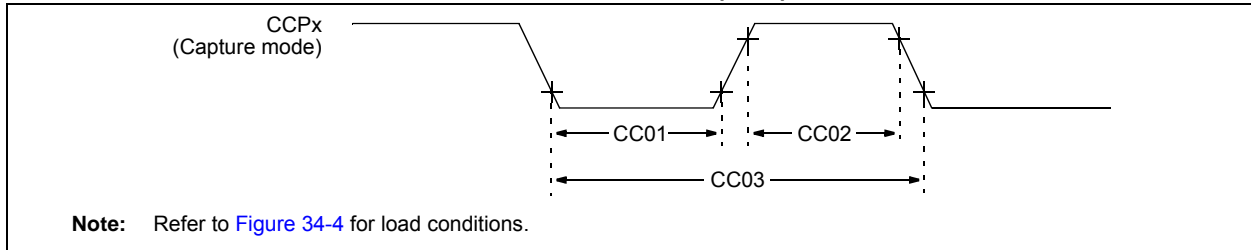
**TABLE 34-12: TIMER0 AND TIMER1 EXTERNAL CLOCK REQUIREMENTS**

Standard Operating Conditions (unless otherwise stated) Operating Temperature $-40^{\circ}\text{C} \leq T_A \leq +125^{\circ}\text{C}$									
Param. No.	Sym.	Characteristic		Min.	Typ.†	Max.	Units	Conditions	
40*	T <sub>T0H</sub>	T0CKI High Pulse Width	No Prescaler	$0.5 T_{CY} + 20$	—	—	ns		
			With Prescaler	10	—	—	ns		
41*	T <sub>T0L</sub>	T0CKI Low Pulse Width	No Prescaler	$0.5 T_{CY} + 20$	—	—	ns		
			With Prescaler	10	—	—	ns		
42*	T <sub>T0P</sub>	T0CKI Period		Greater of: $20$ or $\frac{T_{CY} + 40}{N}$	—	—	ns	N = prescale value	
45*	T <sub>T1H</sub>	T1CKI High Time	Synchronous, No Prescaler	$0.5 T_{CY} + 20$	—	—	ns		
			Synchronous, with Prescaler		15	—	—	ns	
			Asynchronous		30	—	—	ns	
46*	T <sub>T1L</sub>	T1CKI Low Time	Synchronous, No Prescaler	$0.5 T_{CY} + 20$	—	—	ns		
			Synchronous, with Prescaler		15	—	—	ns	
			Asynchronous		30	—	—	ns	
47*	T <sub>T1P</sub>	T1CKI Input Period	Synchronous	Greater of: $30$ or $\frac{T_{CY} + 40}{N}$	—	—	ns	N = prescale value	
			Asynchronous		60	—	—	ns	
48	F <sub>T1</sub>	Secondary Oscillator Input Frequency Range (oscillator enabled by setting bit T1OSCEN)		32.4	$32.768$	33.1	kHz		
49*	TCKEZ <sub>TMR1</sub>	Delay from External Clock Edge to Timer Increment		$2 T_{osc}$	—	$7 T_{osc}$	—	Timers in Sync mode	

\* These parameters are characterized but not tested.

† Data in "Typ" column is at 3.0V, 25°C unless otherwise stated. These parameters are for design guidance only and are not tested.

**FIGURE 34-11: CAPTURE/COMPARE/PWM TIMINGS (CCP)**



**TABLE 34-13: CAPTURE/COMPARE/PWM REQUIREMENTS (CCP)**

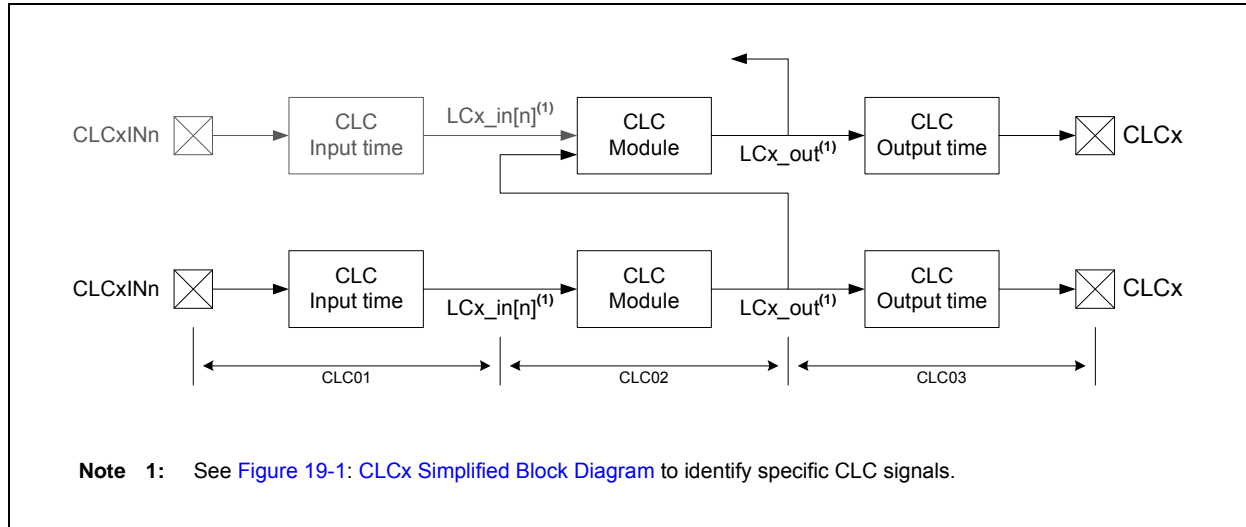
Standard Operating Conditions (unless otherwise stated)								
Operating Temperature $-40^{\circ}\text{C} \leq T_A \leq +125^{\circ}\text{C}$								
Param. No.	Sym.	Characteristic		Min.	Typ.†	Max.	Units	Conditions
CC01*	TccL	CCPx Input Low Time	No Prescaler	$0.5T_{CY} + 20$	—	—	ns	
			With Prescaler	20	—	—	ns	
CC02*	TccH	CCPx Input High Time	No Prescaler	$0.5T_{CY} + 20$	—	—	ns	
			With Prescaler	20	—	—	ns	
CC03*	TccP	CCPx Input Period		$\frac{3T_{CY} + 40}{N}$	—	—	ns	N = prescale value

\* These parameters are characterized but not tested.

† Data in "Typ" column is at 3.0V, 25°C unless otherwise stated. These parameters are for design guidance only and are not tested.

# PIC16(L)F1717/8/9

**FIGURE 34-12: CLC PROPAGATION TIMING**



**TABLE 34-14: CONFIGURATION LOGIC CELL (CLC) CHARACTERISTICS**

Standard Operating Conditions (unless otherwise stated)							
Operating temperature $-40^{\circ}\text{C} \leq T_A \leq +125^{\circ}\text{C}$							
Param. No.	Sym.	Characteristic	Min.	Typ†	Max.	Units	Conditions
CLC01*	TCLCIN	CLC input time	—	7	OS17	ns	(Note 1)
CLC02*	TCLC	CLC module input to output propagation time	—	24	—	ns	$V_{DD} = 1.8\text{V}$
			—	12	—	ns	$V_{DD} > 3.6\text{V}$
CLC03*	TCLCOUT	CLC output time	Rise Time	—	OS18	—	(Note 1)
			Fall Time	—	OS19	—	(Note 1)
CLC04*	FCLCMAX	CLC maximum switching frequency	—	45	—	MHz	

\* These parameters are characterized but not tested.

† Data in "Typ" column is at 3.0V, 25°C unless otherwise stated. These parameters are for design guidance only and are not tested.

**Note 1:** See [Table 34-10](#) for OS17, OS18 and OS19 rise and fall times.

**TABLE 34-15: ANALOG-TO-DIGITAL CONVERTER (ADC) CHARACTERISTICS<sup>(1,2,3,4)</sup>**

Standard Operating Conditions (unless otherwise stated)							
VDD = 3.0V, TA = 25°C, Single-ended, 2 μs TAD, VREF+ = 3V, VREF- = VSS							
Param. No.	Sym.	Characteristic	Min.	Typ.†	Max.	Units	Conditions
AD01	NR	Resolution	—	—	10	bit	
AD02	EIL	Integral Error	—	—	±1.7	LSb	VREF = 3.0V
AD03	EDL	Differential Error	—	—	±1	LSb	No missing codes, VREF = 3.0V
AD04	E0FF	Offset Error	—	—	±2.5	LSb	VREF = 3.0V
AD05	EGN	Gain Error	—	—	±2.0	LSb	VREF = 3.0V
AD06	VREF	Reference Voltage	1.8	—	VDD	V	VREF = (VREF+ minus VREF-)
AD07	VAIN	Full-Scale Range	VSS	—	VREF	V	
AD08	ZAIN	Recommended Impedance of Analog Voltage Source	—	—	10	kΩ	Can go higher if external 0.01μF capacitor is present on input pin.

\* These parameters are characterized but not tested.

† Data in "Typ" column is at 3.0V, 25°C unless otherwise stated. These parameters are for design guidance only and are not tested.

**Note 1:** Total Absolute Error includes integral, differential, offset and gain errors.

**2:** The ADC conversion result never decreases with an increase in the input voltage and has no missing codes.

**3:** ADC VREF is from external VREF+ pin, VDD pin or FVR, whichever is selected as reference input.

**4:** See [Section 35.0 "DC and AC Characteristics Graphs and Charts"](#) for operating characterization.

**TABLE 34-16: ADC CONVERSION REQUIREMENTS**

Standard Operating Conditions (unless otherwise stated)							
Param. No.	Sym.	Characteristic	Min.	Typ.†	Max.	Units	Conditions
AD130*	TAD	ADC Clock Period (TADC)	1.0	—	9.0	μs	FOSC-based
		ADC Internal FRC Oscillator Period (TFRC)	1.0	2	6.0	μs	ADCS<1:0> = 11 (ADC FRC mode)
AD131	TCNV	Conversion Time (not including Acquisition Time) <sup>(1)</sup>	—	11	—	TAD	Set GO/DONE bit to conversion complete
AD132*	TACQ	Acquisition Time	—	5.0	—	μs	
AD133*	THCD	Holding Capacitor Disconnect Time	—	1/2 TAD	—		ADCS<2:0> ≠ x11 (FOSC-based)
			—	1/2 TAD + 1TCY	—		ADCS<2:0> = x11 (FRC-based)

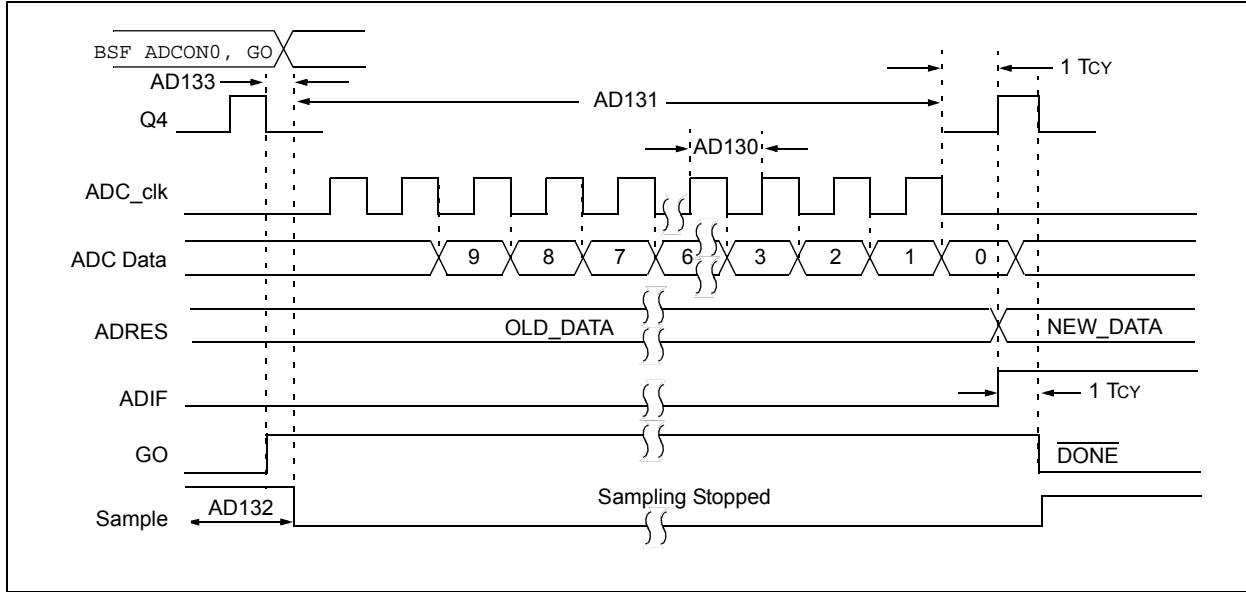
\* These parameters are characterized but not tested.

† Data in "Typ" column is at 3.0V, 25°C unless otherwise stated. These parameters are for design guidance only and are not tested.

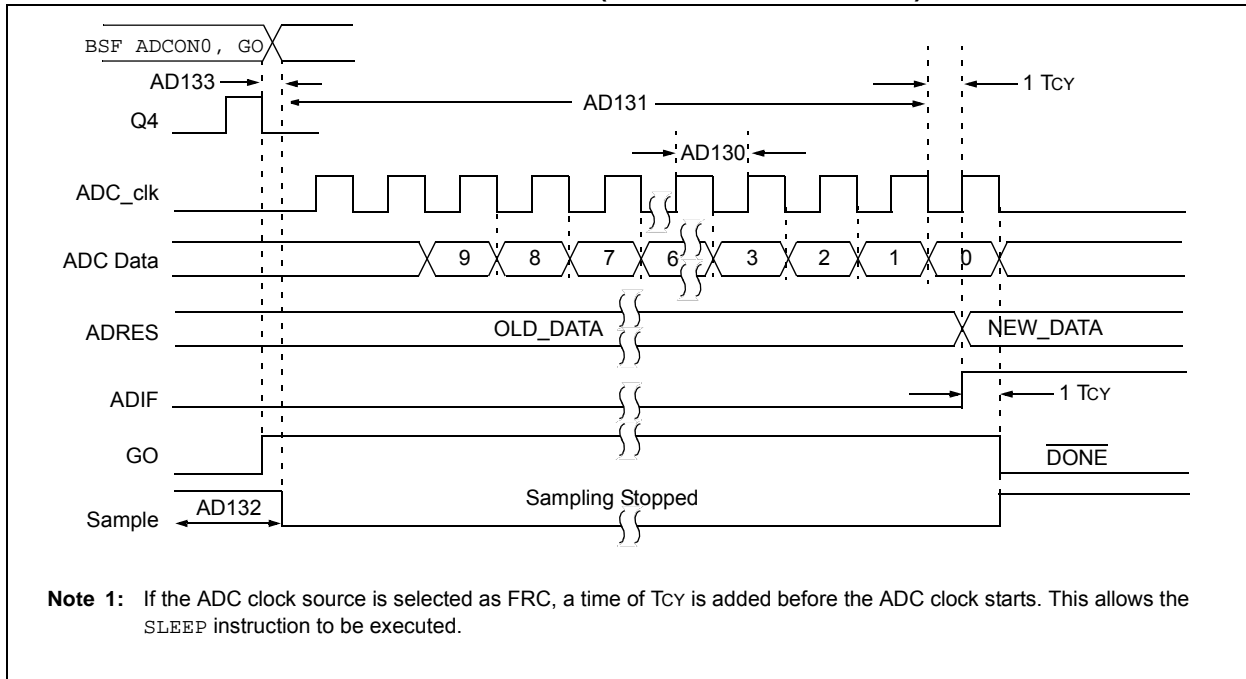
**Note 1:** The ADRES register may be read on the following TCY cycle.

# PIC16(L)F1717/8/9

**FIGURE 34-13: ADC CONVERSION TIMING (ADC CLOCK Fosc-BASED)**



**FIGURE 34-14: ADC CONVERSION TIMING (ADC CLOCK FROM FRC)**



**TABLE 34-17: OPERATIONAL AMPLIFIER (OPA)**

Standard Operating Conditions (unless otherwise stated) VDD = 3.0V, TA = 25°C, OPAXSP = 1 (High GBWP mode)							
Param. No.	Symbol	Characteristics	Min.	Typ.	Max.	Units	Conditions
OPA01*	GBWP	Gain Bandwidth Product	—	2	—	MHz	
OPA02*	TON	Turn on Time	—	10	—	μs	
OPA03*	PM	Phase Margin	—	40	—	degrees	
OPA04*	SR	Slew Rate	—	3	—	V/μs	
OPA05	OFF	Offset	—	±3	±9	mV	
OPA06	CMRR	Common Mode Rejection Ratio	55	70	—	dB	
OPA07*	AOL	Open Loop Gain	—	90	—	dB	
OPA08	VICM	Input Common Mode Voltage	0	—	VDD	V	VDD > 2.5V
OPA09*	PSRR	Power Supply Rejection Ratio	—	80	—	dB	

\* These parameters are characterized but not tested.

**TABLE 34-18: COMPARATOR SPECIFICATIONS**

Standard Operating Conditions (unless otherwise stated) VDD = 3.0V, TA = 25°C See <a href="#">Section 35.0 “DC and AC Characteristics Graphs and Charts”</a> for operating characterization.							
Param. No.	Sym.	Characteristics	Min.	Typ.	Max.	Units	Comments
CM01	VIOFF	Input Offset Voltage	—	±2.5	±5	mV	CxSP = 1, VICM = VDD/2
CM02	VICM	Input Common Mode Voltage	0	—	VDD	V	
CM03	CMRR	Common Mode Rejection Ratio	40	50	—	dB	
CM04A	TRESP <sup>(1)</sup>	Response Time Rising Edge	—	60	85	ns	CxSP = 1
CM04B		Response Time Falling Edge	—	60	90	ns	CxSP = 1
CM04C		Response Time Rising Edge	—	85	—	ns	CxSP = 0
CM04D		Response Time Falling Edge	—	85	—	ns	CxSP = 0
CM05*	TMC2OV	Comparator Mode Change to Output Valid*	—	—	10	μs	
CM06	CHYSTER	Comparator Hysteresis	20	45	75	mV	CxHYS = 1, CxSP = 1

\* These parameters are characterized but not tested.

**Note 1:** Response time measured with one comparator input at VDD/2, while the other input transitions from VSS to VDD.

# PIC16(L)F1717/8/9

**TABLE 34-19: 8-BIT DIGITAL-TO-ANALOG CONVERTER (DAC) SPECIFICATIONS**

Standard Operating Conditions (unless otherwise stated) V <sub>DD</sub> = 3.0V, T <sub>A</sub> = 25°C See <a href="#">Section 35.0 “DC and AC Characteristics Graphs and Charts”</a> for operating characterization.							
Param. No.	Sym.	Characteristics	Min.	Typ.	Max.	Units	Comments
DAC01*	CLSB	Step Size	—	V <sub>DD</sub> /256	—	V	
DAC02*	CACC	Absolute Accuracy	—	—	± 1.5	LSb	
DAC03*	CR	Unit Resistor Value (R)	—	600	—	Ω	
DAC04*	CST	Settling Time <sup>(1)</sup>	—	—	10	μs	

\* These parameters are characterized but not tested.

**Note 1:** Settling time measured while DACR<7:0> transitions from '0x00' to '0xFF'.

**TABLE 34-20: 5-BIT DIGITAL-TO-ANALOG CONVERTER (DAC) SPECIFICATIONS**

Standard Operating Conditions (unless otherwise stated) V <sub>DD</sub> = 3.0V, T <sub>A</sub> = 25°C See <a href="#">Section 35.0 “DC and AC Characteristics Graphs and Charts”</a> for operating characterization.							
Param. No.	Sym.	Characteristics	Min.	Typ.	Max.	Units	Comments
DAC05*	CLSB	Step Size	—	V <sub>DD</sub> /32	—	V	
DAC06*	CACC	Absolute Accuracy	—	—	± 0.5	LSb	
DAC07*	CR	Unit Resistor Value (R)	—	6000	—	Ω	
DAC08*	CST	Settling Time <sup>(1)</sup>	—	—	10	μs	

\* These parameters are characterized but not tested.

**Note 1:** Settling time measured while DACR<7:0> transitions from '0x00' to '0xFF'.

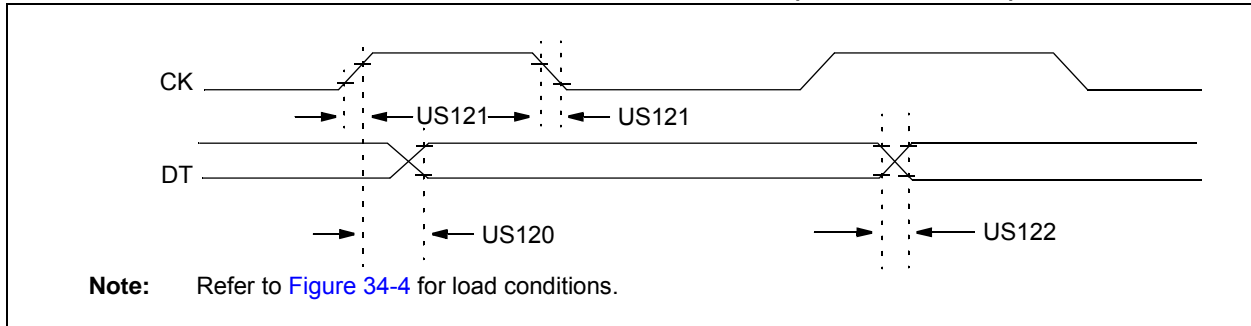
**TABLE 34-21: ZERO-CROSS PIN SPECIFICATIONS**

Standard Operating Conditions (unless otherwise stated) V <sub>DD</sub> = 3.0V, T <sub>A</sub> = 25°C							
Param. No.	Sym.	Characteristics	Min.	Typ.	Max.	Units	Comments
ZC01	ZCPINV	Voltage on Zero-Cross Pin	—	0.75	—	V	
ZC02	ZCSRC	Source current	—	300	—	μA	
ZC03	ZCSNK	Sink current	—	300	—	μA	
ZC04	ZCISW	Response Time Rising Edge	—	1	—	μs	
		Response Time Falling Edge	—	1	—	μs	
ZC05	ZCOUT	Response Time Rising Edge	—	1	—	μs	
		Response Time Falling Edge	—	1	—	μs	

\* These parameters are characterized but not tested.



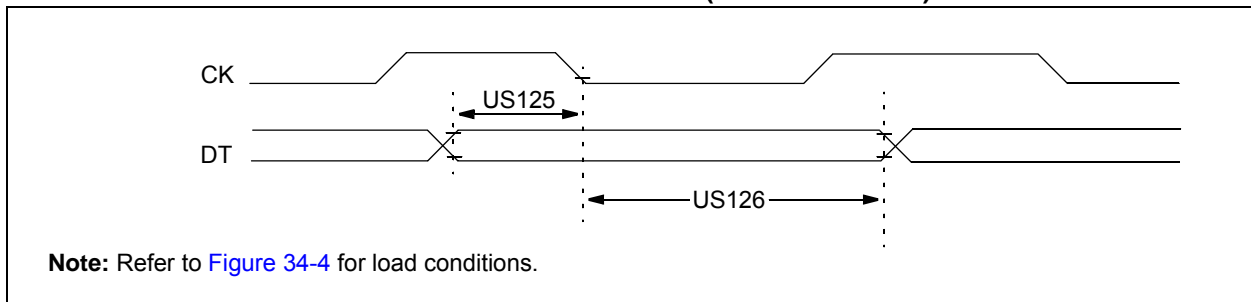
**FIGURE 34-15: EUSART SYNCHRONOUS TRANSMISSION (MASTER/SLAVE) TIMING**



**TABLE 34-22: EUSART SYNCHRONOUS TRANSMISSION REQUIREMENTS**

Standard Operating Conditions (unless otherwise stated)						
Param. No.	Symbol	Characteristic	Min.	Max.	Units	Conditions
US120	TCKH2DTV	SYNC XMIT (Master and Slave) Clock high to data-out valid	—	80	ns	$3.0V \leq V_{DD} \leq 5.5V$
			—	100	ns	$1.8V \leq V_{DD} \leq 5.5V$
US121	TCKRF	Clock out rise time and fall time (Master mode)	—	45	ns	$3.0V \leq V_{DD} \leq 5.5V$
			—	50	ns	$1.8V \leq V_{DD} \leq 5.5V$
US122	TDTRF	Data-out rise time and fall time	—	45	ns	$3.0V \leq V_{DD} \leq 5.5V$
			—	50	ns	$1.8V \leq V_{DD} \leq 5.5V$

**FIGURE 34-16: EUSART SYNCHRONOUS RECEIVE (MASTER/SLAVE) TIMING**

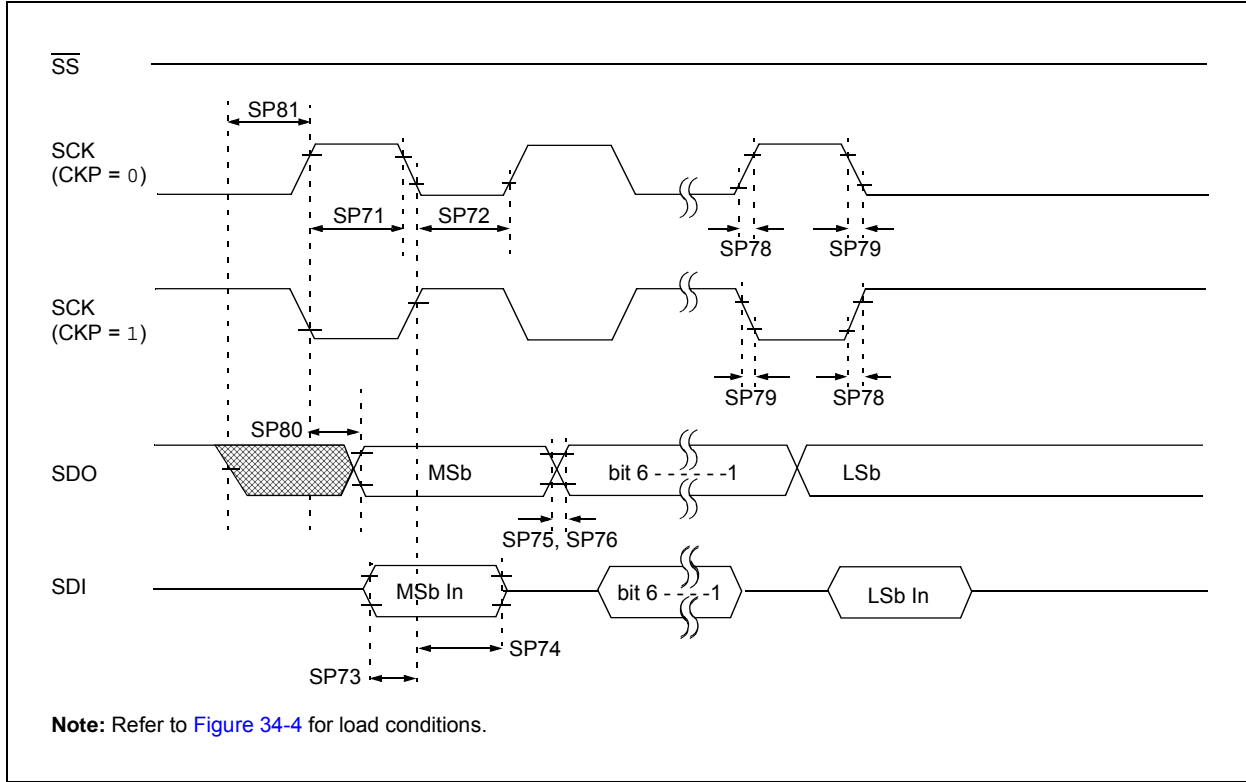


**TABLE 34-23: EUSART SYNCHRONOUS RECEIVE REQUIREMENTS**

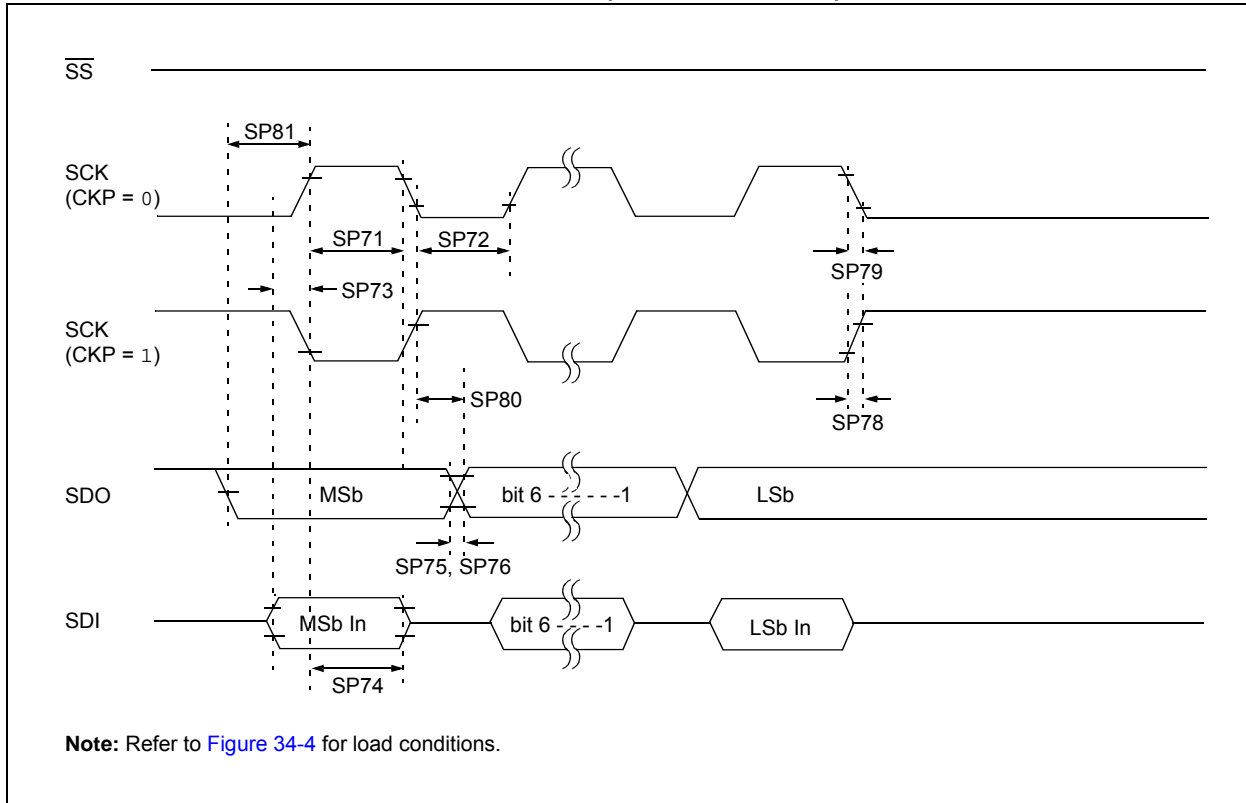
Standard Operating Conditions (unless otherwise stated)						
Param. No.	Symbol	Characteristic	Min.	Max.	Units	Conditions
US125	TDTV2CKL	SYNC RCV (Master and Slave) Data-setup before CK ↓ (DT hold time)	10	—	ns	
US126	TCKL2DTL	Data-hold after CK ↓ (DT hold time)	15	—	ns	

# PIC16(L)F1717/8/9

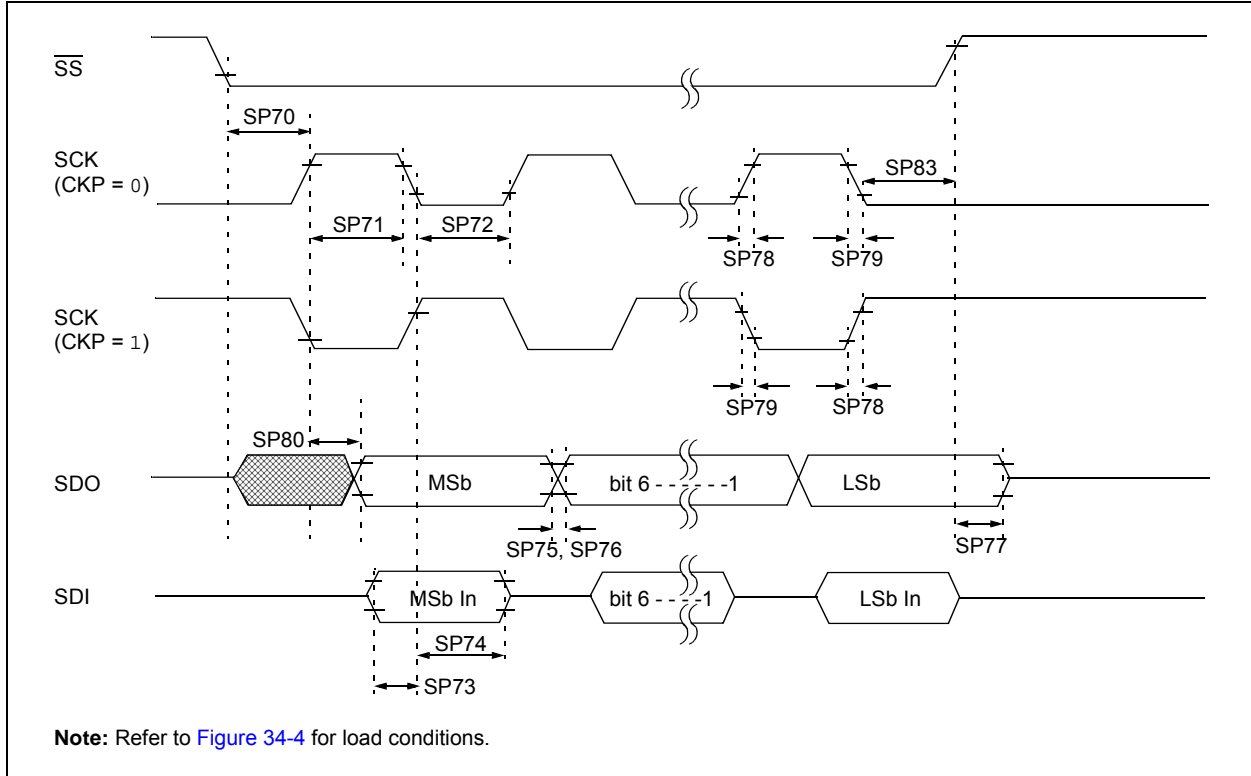
**FIGURE 34-17: SPI MASTER MODE TIMING (CKE = 0, SMP = 0)**



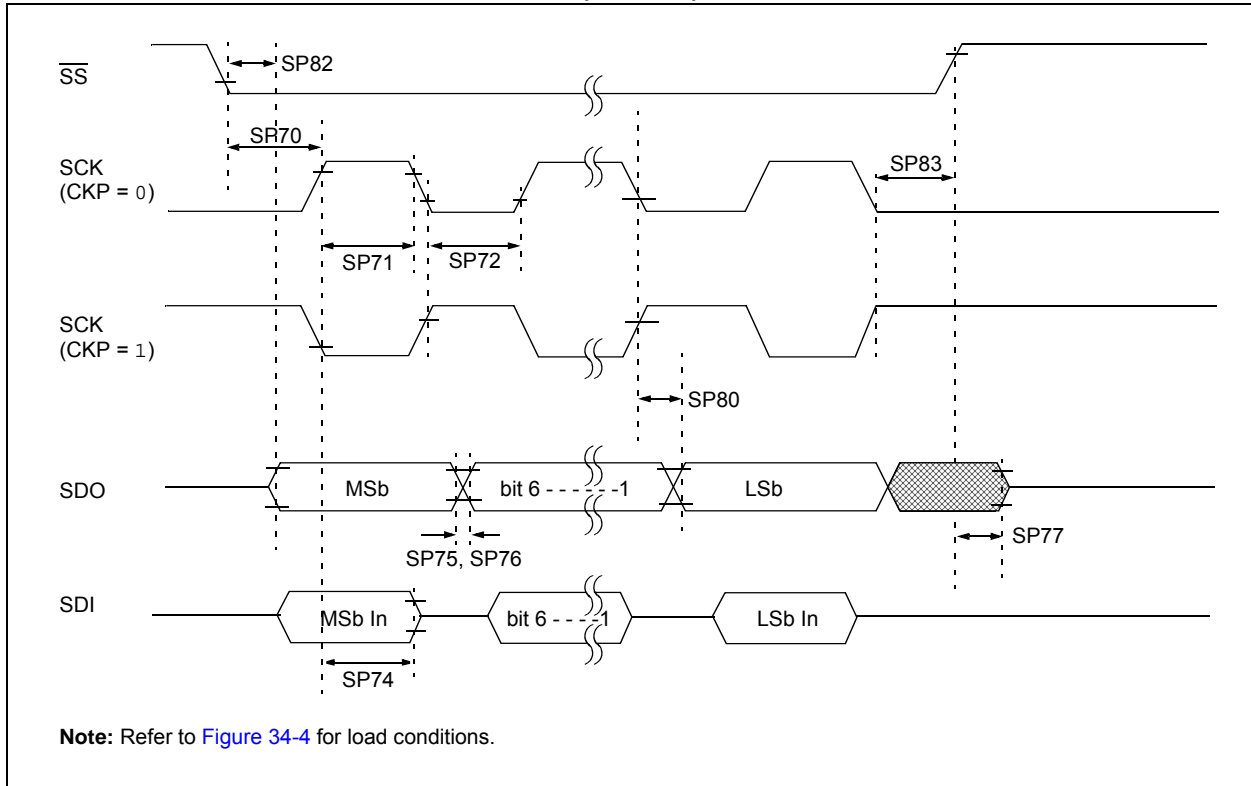
**FIGURE 34-18: SPI MASTER MODE TIMING (CKE = 1, SMP = 1)**



**FIGURE 34-19: SPI SLAVE MODE TIMING (CKE = 0)**



**FIGURE 34-20: SPI SLAVE MODE TIMING (CKE = 1)**



# PIC16(L)F1717/8/9

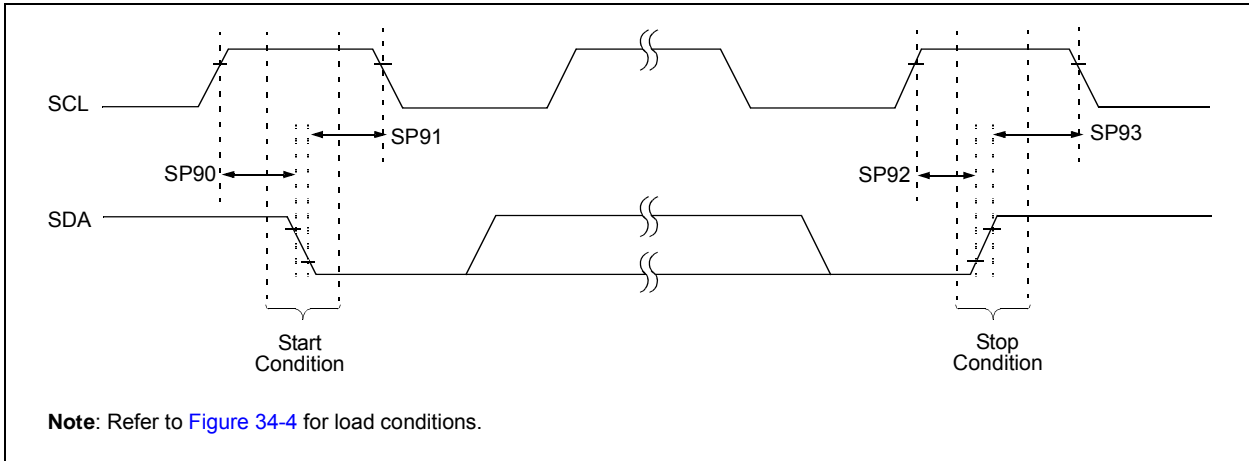
**TABLE 34-24: SPI MODE REQUIREMENTS**

Standard Operating Conditions (unless otherwise stated)							
Param. No.	Symbol	Characteristic	Min.	Typ.†	Max.	Units	Conditions
SP70*	TssL2sCH, TssL2sCL	$\overline{SS}\downarrow$ to SCK $\downarrow$ or SCK $\uparrow$ input	2.25 T <sub>CY</sub>	—	—	ns	
SP71*	TsCH	SCK input high time (Slave mode)	T <sub>CY</sub> + 20	—	—	ns	
SP72*	TsCL	SCK input low time (Slave mode)	T <sub>CY</sub> + 20	—	—	ns	
SP73*	TdIV2sCH, TdIV2sCL	Setup time of SDI data input to SCK edge	100	—	—	ns	
SP74*	TsCH2dIL, TsCL2dIL	Hold time of SDI data input to SCK edge	100	—	—	ns	
SP75*	TDoR	SDO data output rise time	—	10	25	ns	3.0V ≤ V <sub>DD</sub> ≤ 5.5V
			—	25	50	ns	1.8V ≤ V <sub>DD</sub> ≤ 5.5V
SP76*	TDoF	SDO data output fall time	—	10	25	ns	
SP77*	TssH2doZ	$\overline{SS}\uparrow$ to SDO output high-impedance	10	—	50	ns	
SP78*	TscR	SCK output rise time (Master mode)	—	10	25	ns	3.0V ≤ V <sub>DD</sub> ≤ 5.5V
			—	25	50	ns	1.8V ≤ V <sub>DD</sub> ≤ 5.5V
SP79*	TscF	SCK output fall time (Master mode)	—	10	25	ns	
SP80*	TsCH2doV, TsCL2doV	SDO data output valid after SCK edge	—	—	50	ns	3.0V ≤ V <sub>DD</sub> ≤ 5.5V
			—	—	145	ns	1.8V ≤ V <sub>DD</sub> ≤ 5.5V
SP81*	TdoV2sCH, TdoV2sCL	SDO data output setup to SCK edge	1 T <sub>CY</sub>	—	—	ns	
SP82*	TssL2doV	SDO data output valid after $\overline{SS}\downarrow$ edge	—	—	50	ns	
SP83*	TsCH2ssH, TsCL2ssH	$\overline{SS}\uparrow$ after SCK edge	1.5 T <sub>CY</sub> + 40	—	—	ns	

\* These parameters are characterized but not tested.

† Data in "Typ" column is at 3.0V, 25°C unless otherwise stated. These parameters are for design guidance only and are not tested.

**FIGURE 34-21: I<sup>2</sup>C BUS START/STOP BITS TIMING**



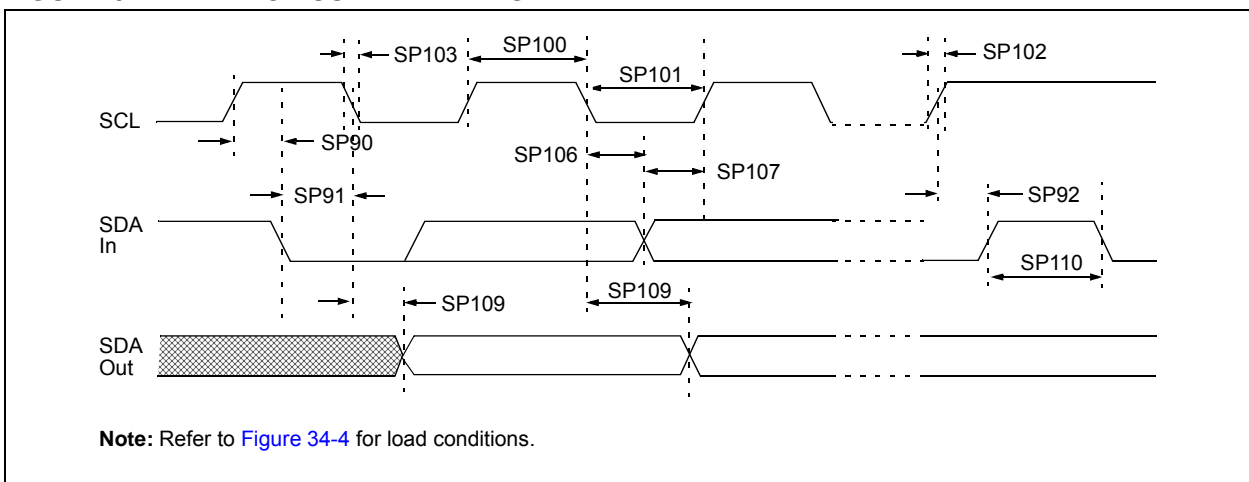
**TABLE 34-25: I<sup>2</sup>C BUS START/STOP BITS REQUIREMENTS**

**Standard Operating Conditions (unless otherwise stated)**

Param. No.	Symbol	Characteristic	Min.	Typ.	Max.	Units	Conditions	
SP90*	TSU:STA	Start condition Setup time	100 kHz mode	4700	—	—	ns	Only relevant for Repeated Start condition
			400 kHz mode	600	—	—		
SP91*	THD:STA	Start condition Hold time	100 kHz mode	4000	—	—	ns	After this period, the first clock pulse is generated
			400 kHz mode	600	—	—		
SP92*	TSU:STO	Stop condition Setup time	100 kHz mode	4700	—	—	ns	
			400 kHz mode	600	—	—		
SP93	THD:STO	Stop condition Hold time	100 kHz mode	4000	—	—	ns	
			400 kHz mode	600	—	—		

\* These parameters are characterized but not tested.

**FIGURE 34-22: I<sup>2</sup>C BUS DATA TIMING**



# PIC16(L)F1717/8/9

TABLE 34-26: I<sup>2</sup>C BUS DATA REQUIREMENTS

Standard Operating Conditions (unless otherwise stated)							
Param. No.	Symbol	Characteristic		Min.	Max.	Units	Conditions
SP100*	THIGH	Clock high time	100 kHz mode	4.0	—	μs	Device must operate at a minimum of 1.5 MHz
			400 kHz mode	0.6	—	μs	Device must operate at a minimum of 10 MHz
			SSP module	1.5T <sub>CY</sub>	—		
SP101*	TLOW	Clock low time	100 kHz mode	4.7	—	μs	Device must operate at a minimum of 1.5 MHz
			400 kHz mode	1.3	—	μs	Device must operate at a minimum of 10 MHz
			SSP module	1.5T <sub>CY</sub>	—		
SP102*	TR	SDA and SCL rise time	100 kHz mode	—	1000	ns	
			400 kHz mode	20 + 0.1C <sub>B</sub>	300	ns	C <sub>B</sub> is specified to be from 10-400 pF
SP103*	TF	SDA and SCL fall time	100 kHz mode	—	250	ns	
			400 kHz mode	20 + 0.1C <sub>B</sub>	250	ns	C <sub>B</sub> is specified to be from 10-400 pF
SP106*	THD:DAT	Data input hold time	100 kHz mode	0	—	ns	
			400 kHz mode	0	0.9	μs	
SP107*	TSU:DAT	Data input setup time	100 kHz mode	250	—	ns	(Note 2)
			400 kHz mode	100	—	ns	
SP109*	TAA	Output valid from clock	100 kHz mode	—	3500	ns	(Note 1)
			400 kHz mode	—	—	ns	
SP110*	TBUF	Bus free time	100 kHz mode	4.7	—	μs	Time the bus must be free before a new transmission can start
			400 kHz mode	1.3	—	μs	
SP111	C <sub>B</sub>	Bus capacitive loading		—	400	pF	

\* These parameters are characterized but not tested.

- Note 1:** As a transmitter, the device must provide this internal minimum delay time to bridge the undefined region (min. 300 ns) of the falling edge of SCL to avoid unintended generation of Start or Stop conditions.
- 2:** A Fast mode (400 kHz) I<sup>2</sup>C bus device can be used in a Standard mode (100 kHz) I<sup>2</sup>C bus system, but the requirement TSU:DAT ≥ 250 ns must then be met. This will automatically be the case if the device does not stretch the low period of the SCL signal. If such a device does stretch the low period of the SCL signal, it must output the next data bit to the SDA line TR max. + TSU:DAT = 1000 + 250 = 1250 ns (according to the Standard mode I<sup>2</sup>C bus specification), before the SCL line is released.



# PIC16(L)F1717/8/9

---

## 35.0 DC AND AC CHARACTERISTICS GRAPHS AND CHARTS

The graphs and tables provided in this section are for **design guidance** and are **not tested**.

In some graphs or tables, the data presented are **outside specified operating range** (i.e., outside specified  $V_{DD}$  range). This is for **information only** and devices are ensured to operate properly only within the specified range.

Unless otherwise noted, all graphs apply to both the L and LF devices.

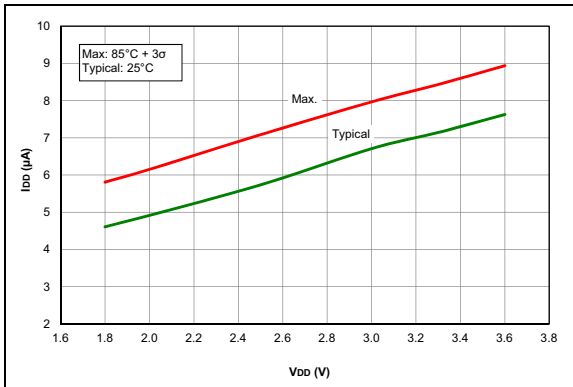
<p><b>Note:</b> The graphs and tables provided following this note are a statistical summary based on a limited number of samples and are provided for informational purposes only. The performance characteristics listed herein are not tested or guaranteed. In some graphs or tables, the data presented may be outside the specified operating range (e.g., outside specified power supply range) and therefore, outside the warranted range.</p>
--

**“Typical”** represents the mean of the distribution at 25°C. **“Maximum”, “Max.”, “Minimum” or “Min.”** represents  $(\text{mean} + 3\sigma)$  or  $(\text{mean} - 3\sigma)$  respectively, where  $\sigma$  is a standard deviation, over each temperature range.

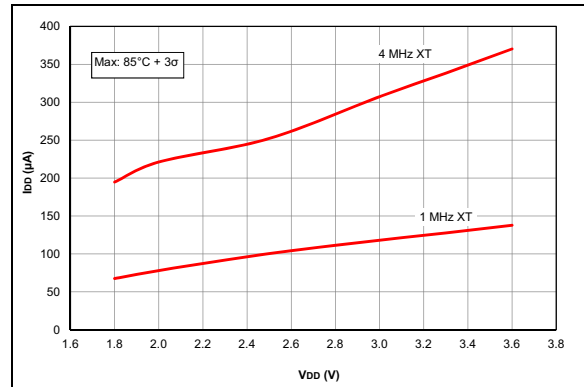


# PIC16(L)F1717/8/9

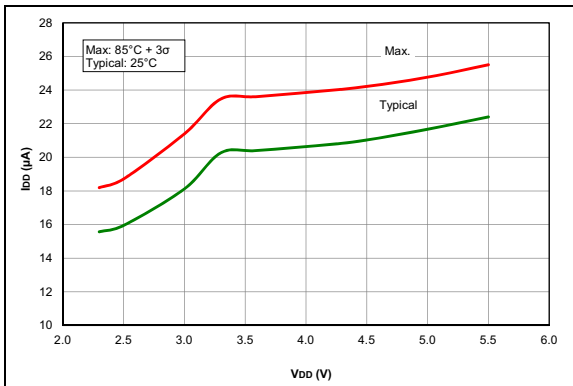
**Note:** Unless otherwise noted,  $V_{IN} = 5V$ ,  $F_{OSC} = 500\text{ kHz}$ ,  $C_{IN} = 0.1\ \mu\text{F}$ ,  $T_A = 25^\circ\text{C}$ .



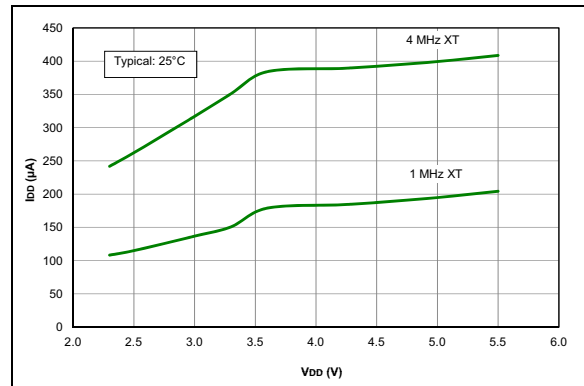
**FIGURE 35-1:**  $I_{DD}$ , LP Oscillator Mode,  $F_{osc} = 32\text{ kHz}$ , PIC16LF1717/8/9 Only.



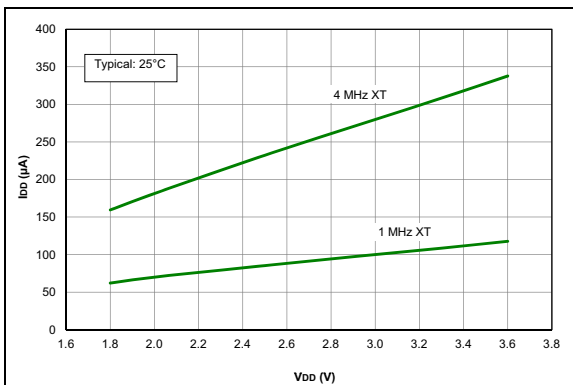
**FIGURE 35-4:**  $I_{DD}$  Maximum, XT and EXTRC Oscillator, PIC16LF1717/8/9 Only.



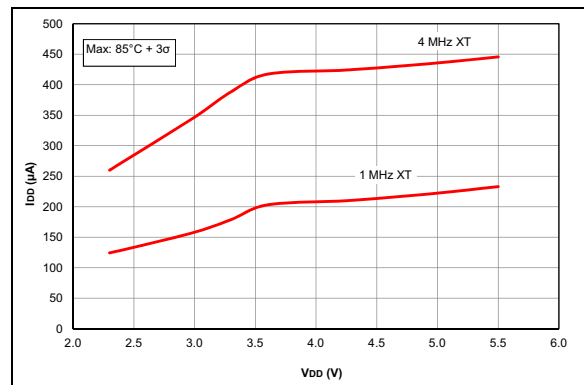
**FIGURE 35-2:**  $I_{DD}$ , LP Oscillator Mode,  $F_{osc} = 32\text{ kHz}$ , PIC16F1717/8/9 Only.



**FIGURE 35-5:**  $I_{DD}$  Typical, XT and EXTRC Oscillator, PIC16F1717/8/9 Only.



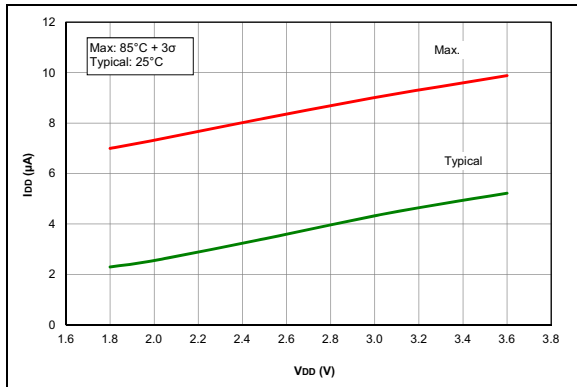
**FIGURE 35-3:**  $I_{DD}$  Typical, XT and EXTRC Oscillator, PIC16LF1717/8/9 Only.



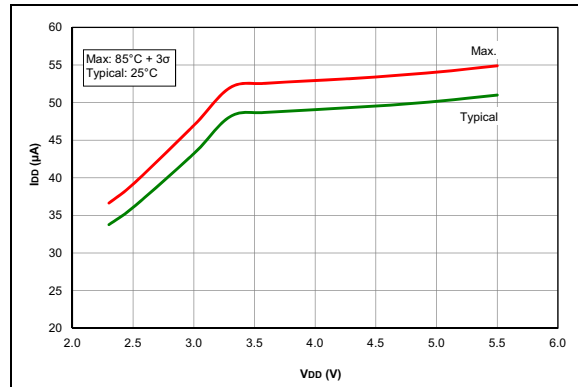
**FIGURE 35-6:**  $I_{DD}$  Maximum, XT and EXTRC Oscillator, PIC16F1717/8/9 Only.

# PIC16(L)F1717/8/9

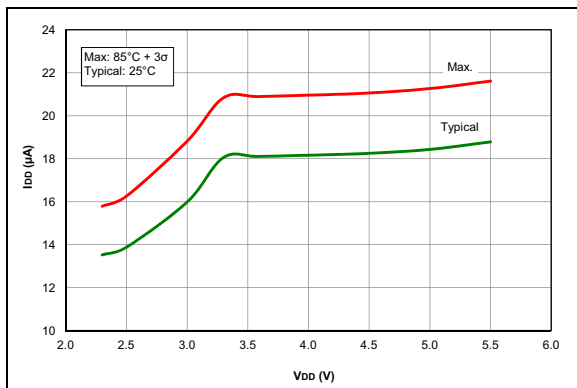
Note: Unless otherwise noted,  $V_{IN} = 5V$ ,  $F_{OSC} = 500\text{ kHz}$ ,  $C_{IN} = 0.1\ \mu F$ ,  $T_A = 25^\circ C$ .



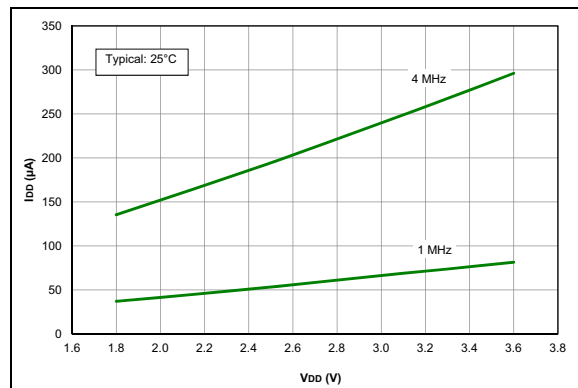
**FIGURE 35-7:**  $I_{DD}$ , EC Oscillator LP Mode,  $F_{osc} = 32\text{ kHz}$ , PIC16LF1717/8/9 Only.



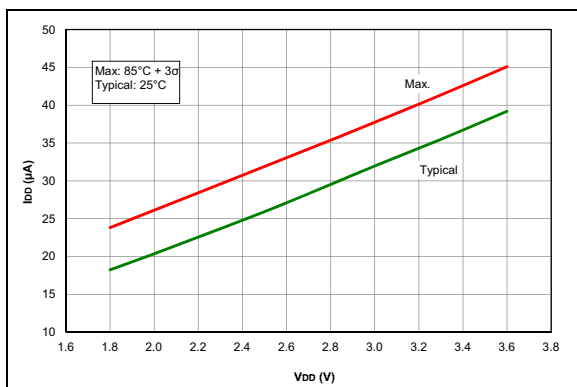
**FIGURE 35-10:**  $I_{DD}$ , EC Oscillator LP Mode,  $F_{osc} = 500\text{ kHz}$ , PIC16LF1717/8/9 Only.



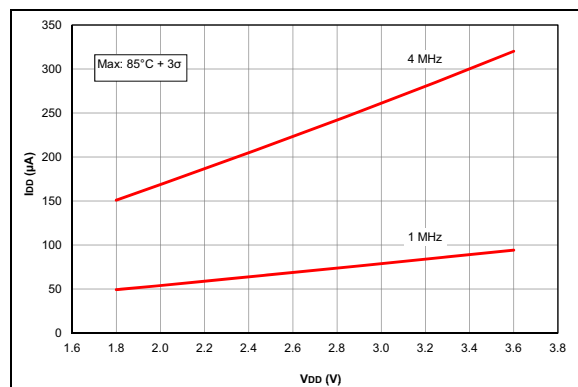
**FIGURE 35-8:**  $I_{DD}$ , EC Oscillator LP Mode,  $F_{osc} = 32\text{ kHz}$ , PIC16LF1717/8/9 Only.



**FIGURE 35-11:**  $I_{DD}$  Typical, EC Oscillator MP Mode, PIC16LF1717/8/9 Only.



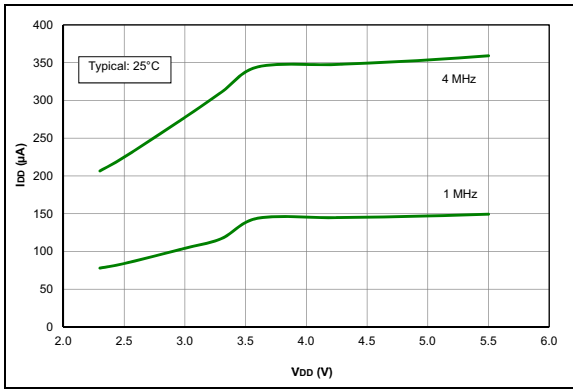
**FIGURE 35-9:**  $I_{DD}$ , EC Oscillator LP Mode,  $F_{osc} = 500\text{ kHz}$ , PIC16LF1717/8/9 Only.



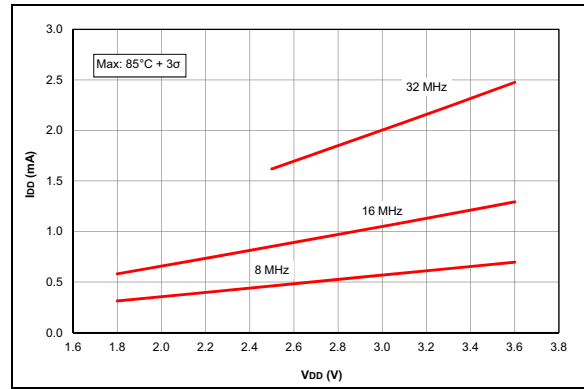
**FIGURE 35-12:**  $I_{DD}$  Maximum, EC Oscillator MP Mode, PIC16LF1717/8/9 Only.

# PIC16(L)F1717/8/9

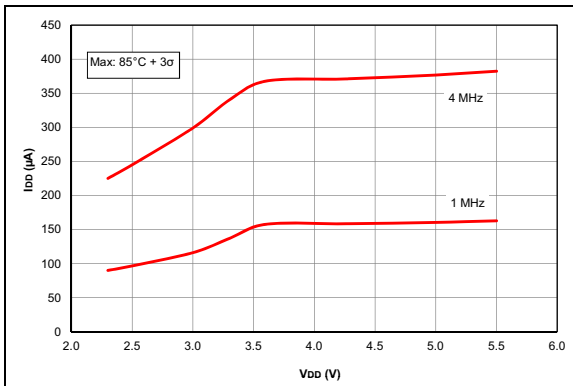
**Note:** Unless otherwise noted,  $V_{IN} = 5V$ ,  $F_{OSC} = 500\text{ kHz}$ ,  $C_{IN} = 0.1\ \mu\text{F}$ ,  $T_A = 25^\circ\text{C}$ .



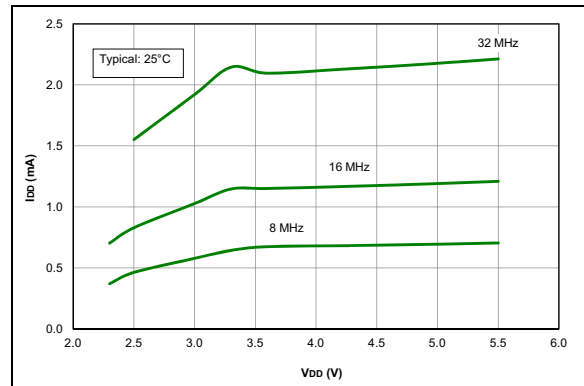
**FIGURE 35-13:**  $I_{DD}$  Typical, EC Oscillator MP Mode, PIC16F1717/8/9 Only.



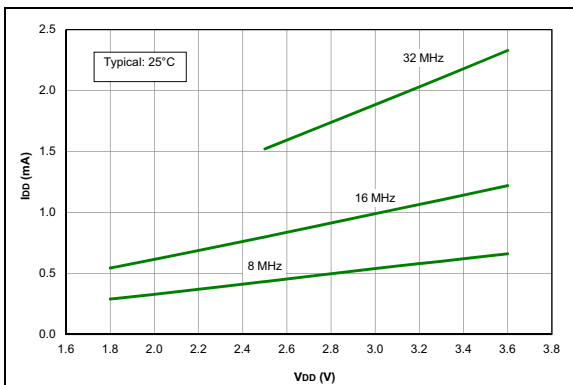
**FIGURE 35-16:**  $I_{DD}$  Maximum, EC Oscillator HP Mode, PIC16LF1717/8/9 Only.



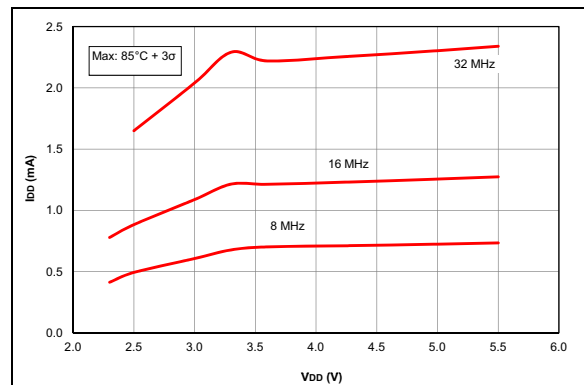
**FIGURE 35-14:**  $I_{DD}$  Maximum, EC Oscillator MP Mode, PIC16F1717/8/9 Only.



**FIGURE 35-17:**  $I_{DD}$  Typical, EC Oscillator HP Mode, PIC16F1717/8/9 Only.



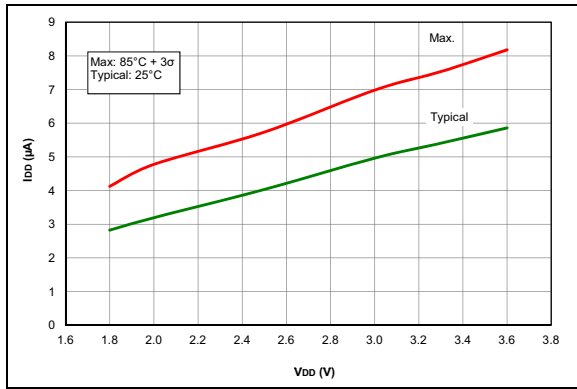
**FIGURE 35-15:**  $I_{DD}$  Typical, EC Oscillator HP Mode, PIC16LF1717/8/9 Only.



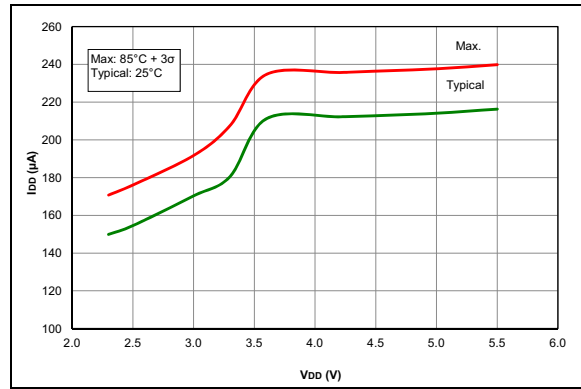
**FIGURE 35-18:**  $I_{DD}$  Maximum, EC Oscillator HP Mode, PIC16F1717/8/9 Only.

# PIC16(L)F1717/8/9

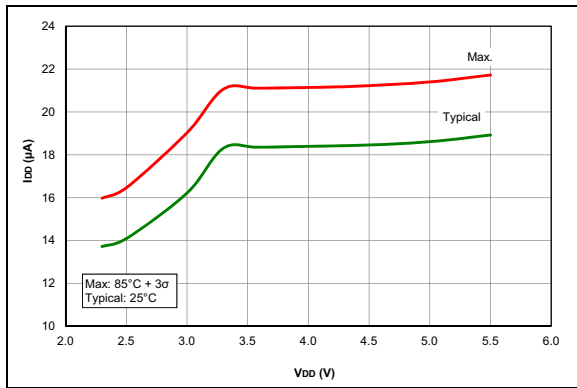
Note: Unless otherwise noted,  $V_{IN} = 5V$ ,  $F_{OSC} = 500\text{ kHz}$ ,  $C_{IN} = 0.1\ \mu F$ ,  $T_A = 25^\circ C$ .



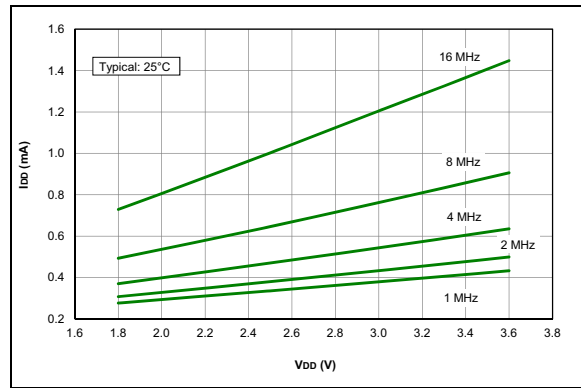
**FIGURE 35-19:**  $I_{DD}$ , LFINTOSC Mode,  $F_{osc} = 31\text{ kHz}$ , PIC16LF1717/8/9 Only.



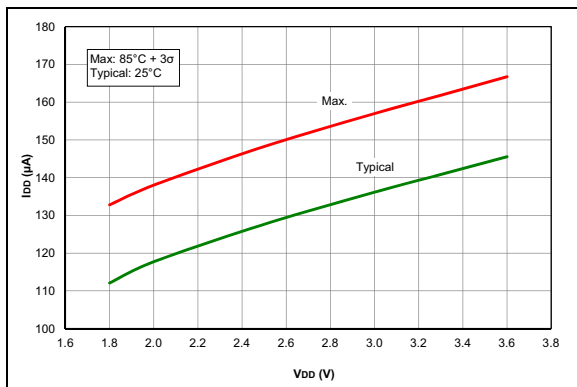
**FIGURE 35-22:**  $I_{DD}$ , MFINTOSC Mode,  $F_{osc} = 500\text{ kHz}$ , PIC16F1717/8/9 Only.



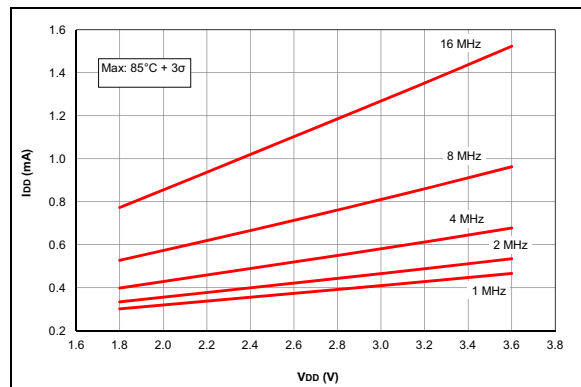
**FIGURE 35-20:**  $I_{DD}$ , LFINTOSC Mode,  $F_{osc} = 31\text{ kHz}$ , PIC16F1717/8/9 Only.



**FIGURE 35-23:**  $I_{DD}$  Typical, HFINTOSC Mode, PIC16LF1717/8/9 Only.



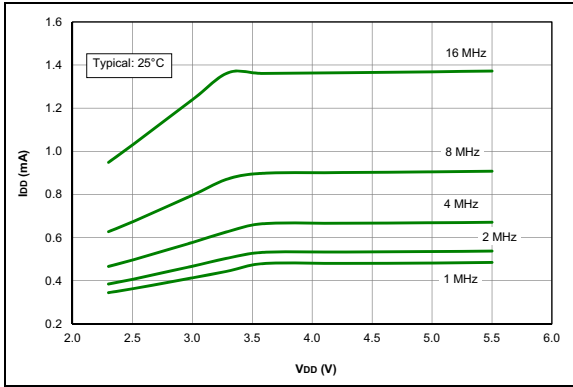
**FIGURE 35-21:**  $I_{DD}$  Maximum, MFINTOSC Mode,  $F_{osc} = 500\text{ kHz}$ , PIC16LF1717/8/9 Only.



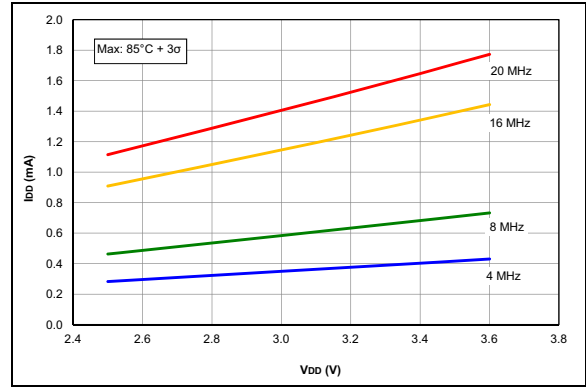
**FIGURE 35-24:**  $I_{DD}$  Maximum, HFINTOSC Mode, PIC16LF1717/8/9 Only.

# PIC16(L)F1717/8/9

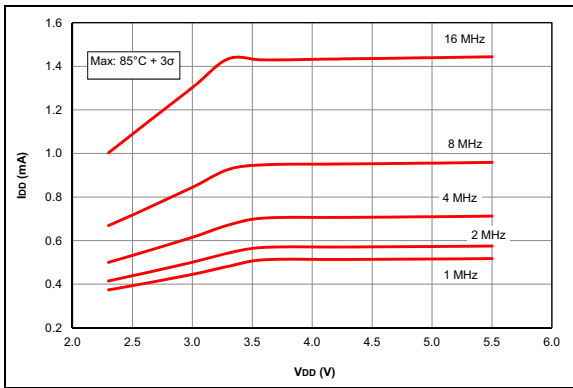
**Note:** Unless otherwise noted,  $V_{IN} = 5V$ ,  $F_{OSC} = 500\text{ kHz}$ ,  $C_{IN} = 0.1\ \mu F$ ,  $T_A = 25^\circ C$ .



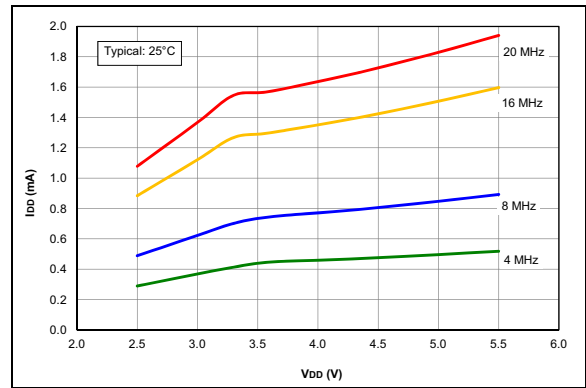
**FIGURE 35-25:**  $I_{DD}$  Typical, HFINTOSC Mode, PIC16F1717/8/9 Only.



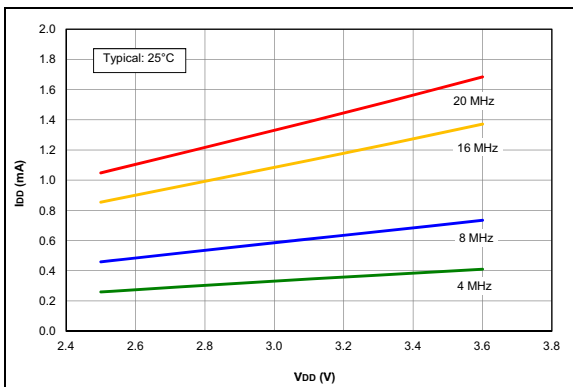
**FIGURE 35-28:**  $I_{DD}$  Maximum, HS Oscillator, PIC16LF1717/8/9 Only.



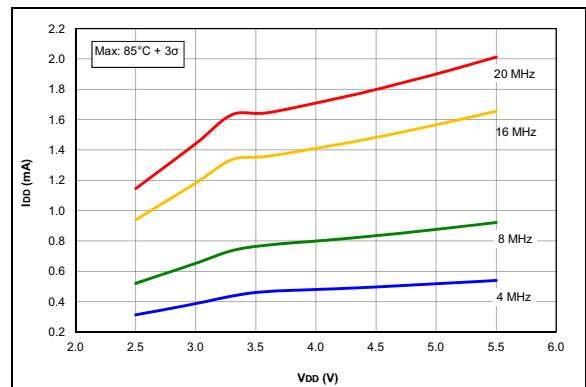
**FIGURE 35-26:**  $I_{DD}$  Maximum, HFINTOSC Mode, PIC16F1717/8/9 Only.



**FIGURE 35-29:**  $I_{DD}$  Typical, HS Oscillator,  $25^\circ C$ , PIC16F1717/8/9 Only.



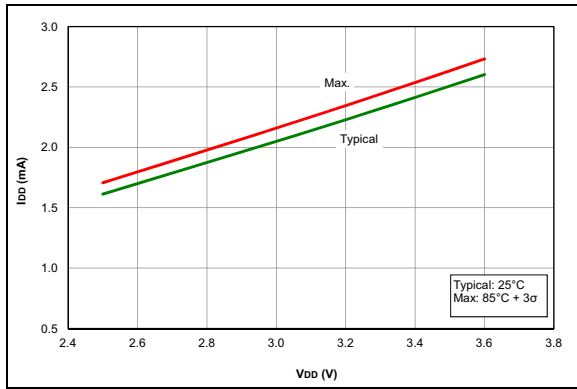
**FIGURE 35-27:**  $I_{DD}$  Typical, HS Oscillator,  $25^\circ C$ , PIC16LF1717/8/9 Only.



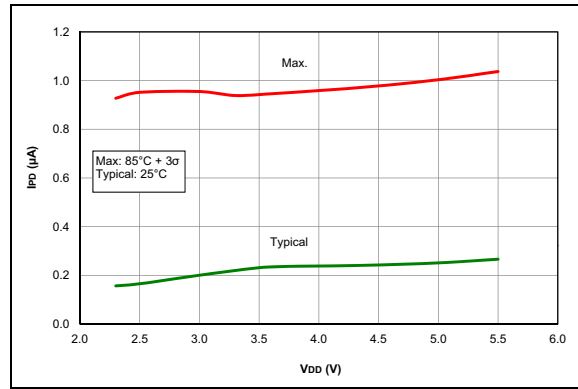
**FIGURE 35-30:**  $I_{DD}$  Maximum, HS Oscillator, PIC16F1717/8/9 Only.

# PIC16(L)F1717/8/9

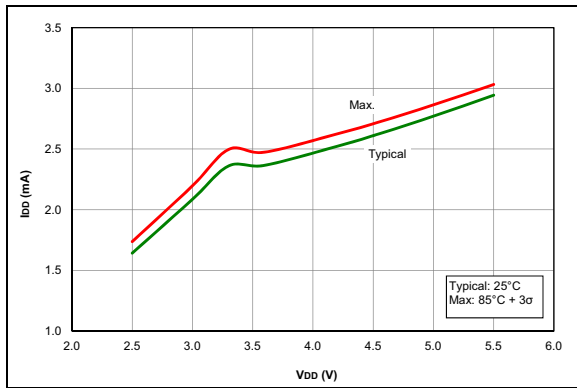
Note: Unless otherwise noted,  $V_{IN} = 5V$ ,  $F_{OSC} = 500\text{ kHz}$ ,  $C_{IN} = 0.1\ \mu F$ ,  $T_A = 25^\circ C$ .



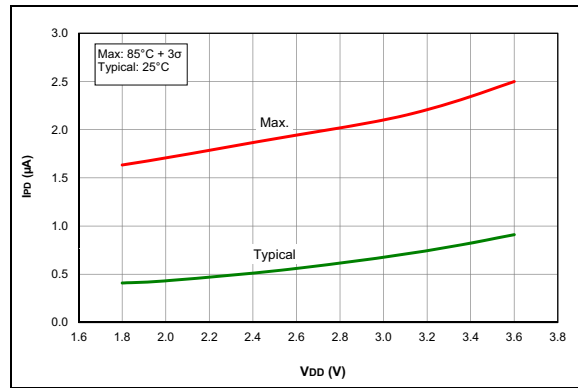
**FIGURE 35-31:**  $I_{DD}$ , HS Oscillator, 32 MHz (8 MHz + 4x PLL), PIC16LF1717/8/9 Only.



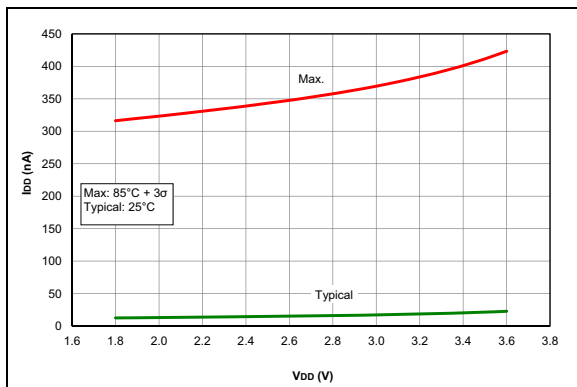
**FIGURE 35-34:**  $I_{PD}$  Base, LP Sleep Mode (VREGPM = 1), PIC16LF1717/8/9 Only.



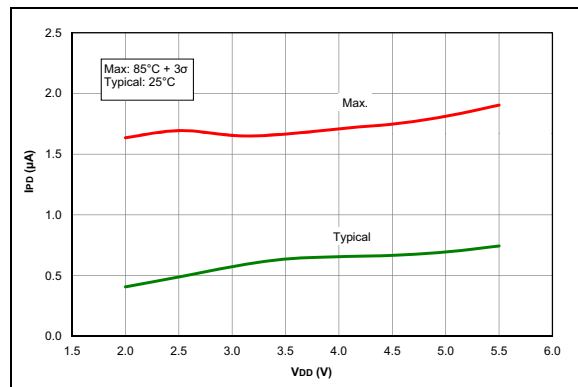
**FIGURE 35-32:**  $I_{DD}$ , HS Oscillator, 32 MHz (8 MHz + 4x PLL), PIC16LF1717/8/9 Only.



**FIGURE 35-35:**  $I_{PD}$ , Watchdog Timer (WDT), PIC16LF1717/8/9 Only.

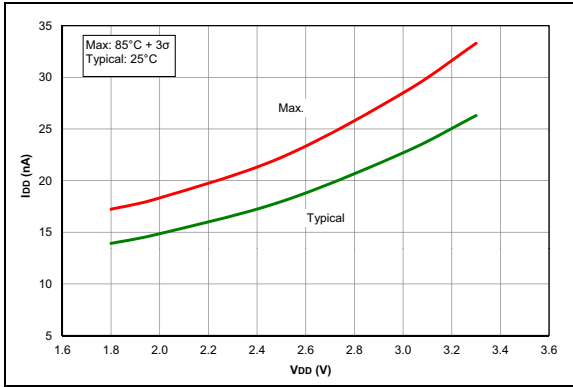


**FIGURE 35-33:**  $I_{PD}$  Base, LP Sleep Mode, PIC16LF1717/8/9 Only.

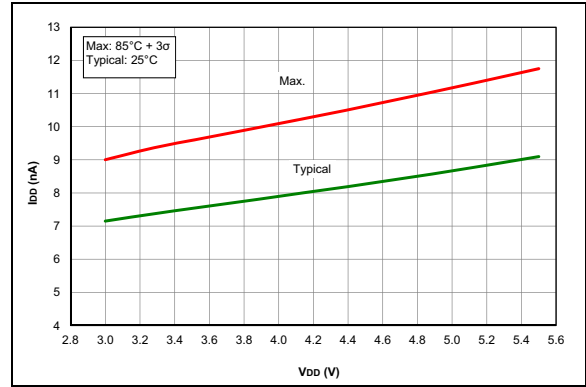


**FIGURE 35-36:**  $I_{PD}$ , Watchdog Timer (WDT), PIC16LF1717/8/9 Only.

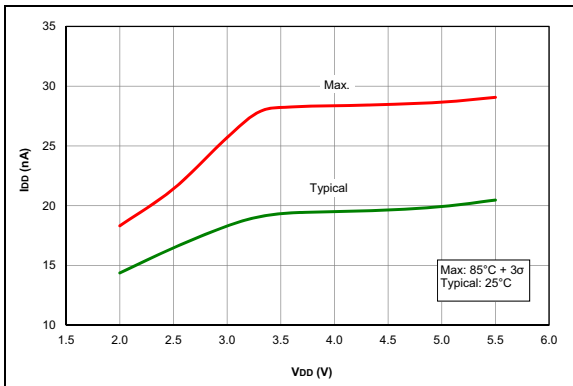
**Note:** Unless otherwise noted,  $V_{IN} = 5V$ ,  $F_{OSC} = 500\text{ kHz}$ ,  $C_{IN} = 0.1\ \mu F$ ,  $T_A = 25^\circ C$ .



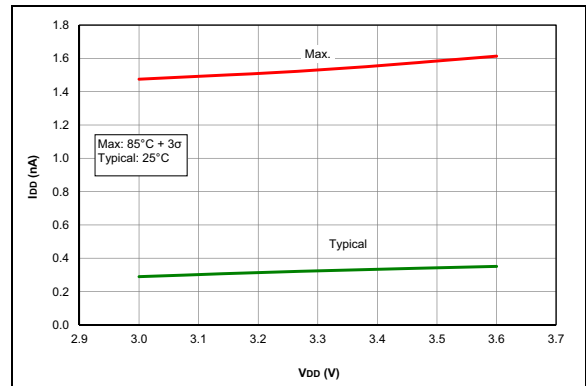
**FIGURE 35-37:**  $I_{PO}$ , Fixed Voltage Reference (FVR), PIC16LF1717/8/9 Only.



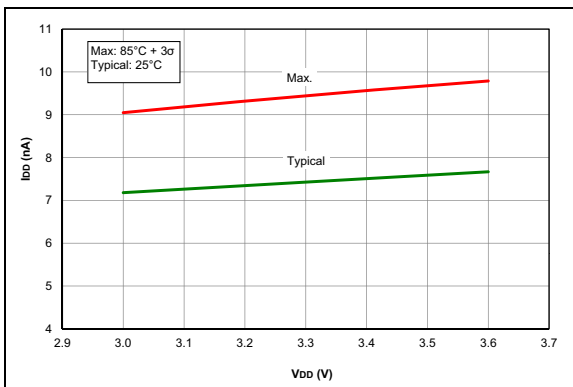
**FIGURE 35-40:**  $I_{PO}$ , Brown-out Reset (BOR), BORV = 1, PIC16F1717/8/9 Only.



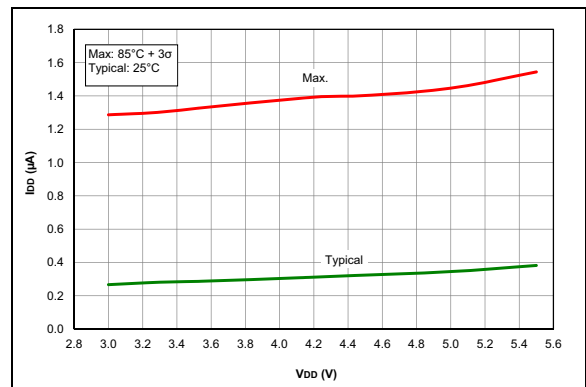
**FIGURE 35-38:**  $I_{PO}$ , Fixed Voltage Reference (FVR), PIC16F1717/8/9 Only.



**FIGURE 35-41:**  $I_{PO}$ , LP Brown-out Reset (LPBOR = 0), PIC16LF1717/8/9 Only.



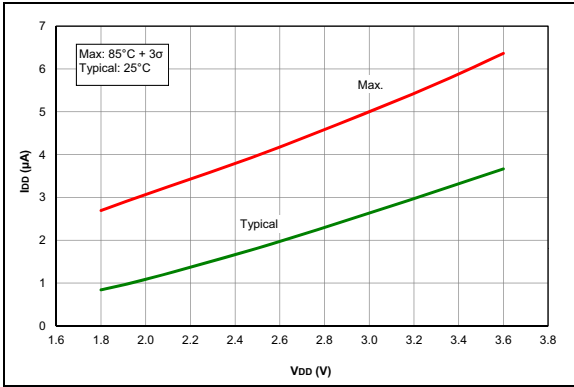
**FIGURE 35-39:**  $I_{PO}$ , Brown-out Reset (BOR), BORV = 1, PIC16LF1717/8/9 Only.



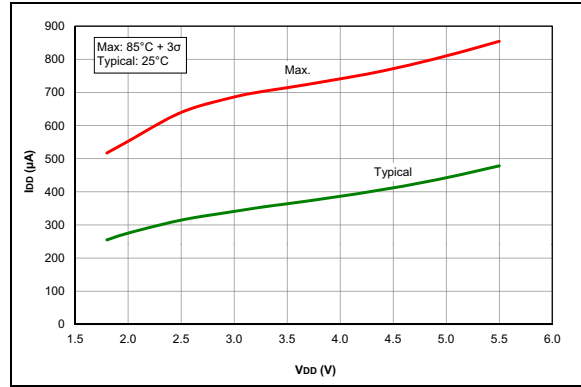
**FIGURE 35-42:**  $I_{PO}$ , LP Brown-out Reset (LPBOR = 0), PIC16F1717/8/9 Only.

# PIC16(L)F1717/8/9

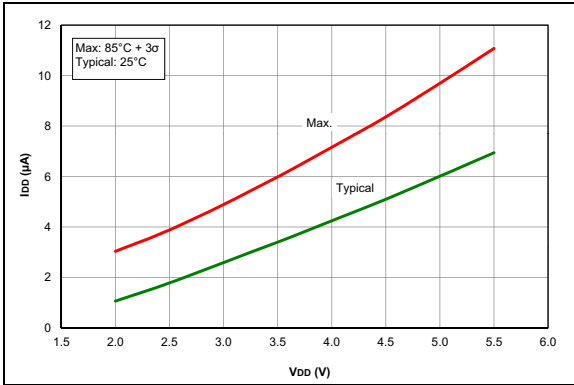
Note: Unless otherwise noted,  $V_{IN} = 5V$ ,  $F_{OSC} = 500\text{ kHz}$ ,  $C_{IN} = 0.1\ \mu F$ ,  $T_A = 25^\circ C$ .



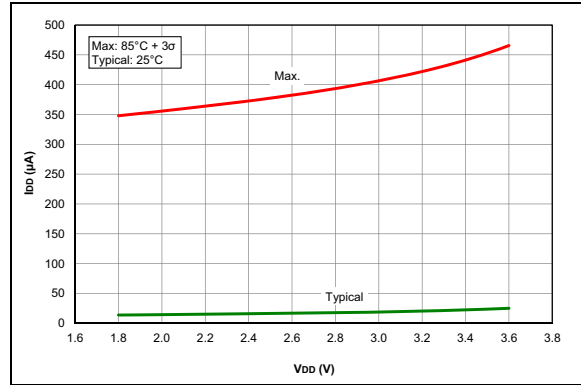
**FIGURE 35-43:**  $I_{DD}$ , Timer1 Oscillator,  $F_{OSC} = 32\text{ kHz}$ , PIC16LF1717/8/9 Only.



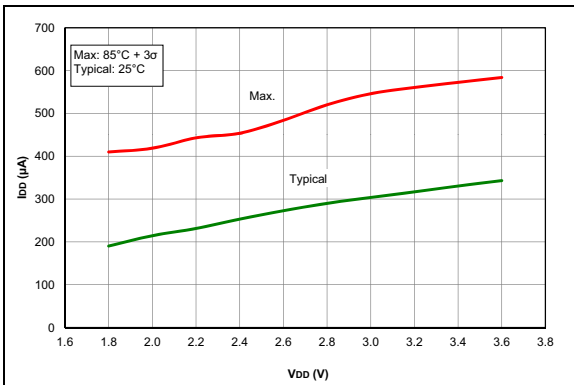
**FIGURE 35-46:**  $I_{DD}$ , Op Amp, High GBWP Mode ( $OPAxSP = 1$ ), PIC16F1717/8/9 Only.



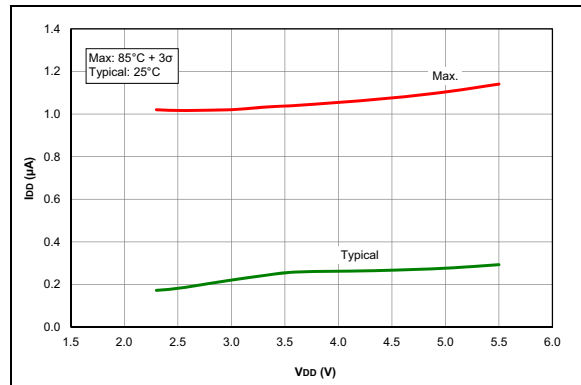
**FIGURE 35-44:**  $I_{DD}$ , Timer1 Oscillator,  $F_{OSC} = 32\text{ kHz}$ , PIC16F1717/8/9 Only.



**FIGURE 35-47:**  $I_{DD}$ , ADC Non-Converting, PIC16LF1717/8/9 Only.



**FIGURE 35-45:**  $I_{DD}$ , Op Amp, High GBWP Mode ( $OPAxSP = 1$ ), PIC16LF1717/8/9 Only.

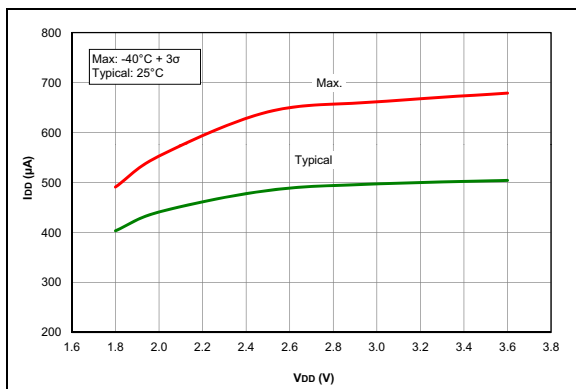


**FIGURE 35-48:**  $I_{DD}$ , ADC Non-Converting, PIC16F1717/8/9 Only.

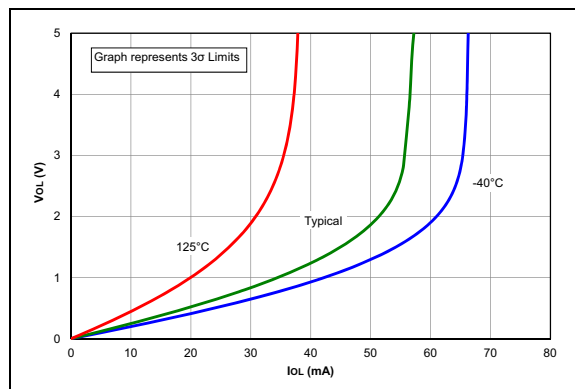


# PIC16(L)F1717/8/9

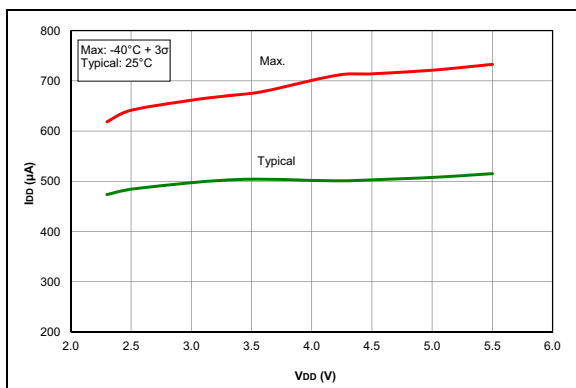
**Note:** Unless otherwise noted,  $V_{IN} = 5V$ ,  $F_{OSC} = 500\text{ kHz}$ ,  $C_{IN} = 0.1\ \mu\text{F}$ ,  $T_A = 25^\circ\text{C}$ .



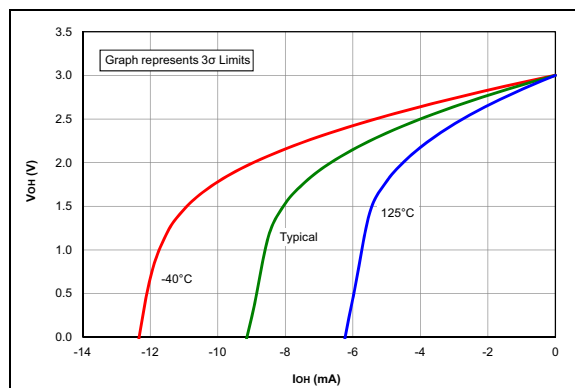
**FIGURE 35-49:**  $I_{DD}$ , Comparator, NP Mode ( $CxSP = 1$ ), PIC16LF1717/8/9 Only.



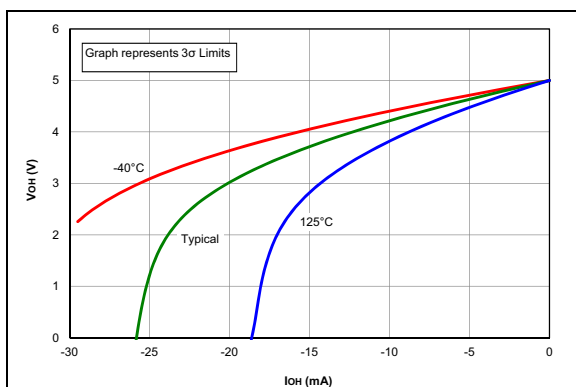
**FIGURE 35-52:**  $V_{OL}$  vs.  $I_{OL}$  Over Temperature,  $V_{DD} = 5.0V$ , PIC16F1717/8/9 Only.



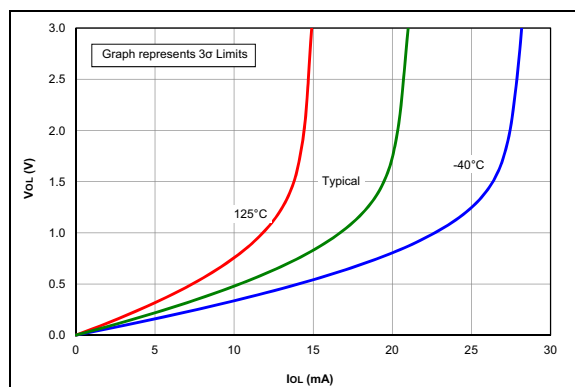
**FIGURE 35-50:**  $I_{DD}$ , Comparator, NP Mode ( $CxSP = 1$ ), PIC16F1717/8/9 Only.



**FIGURE 35-53:**  $V_{OH}$  vs.  $I_{OH}$  Over Temperature,  $V_{DD} = 3.0V$ .



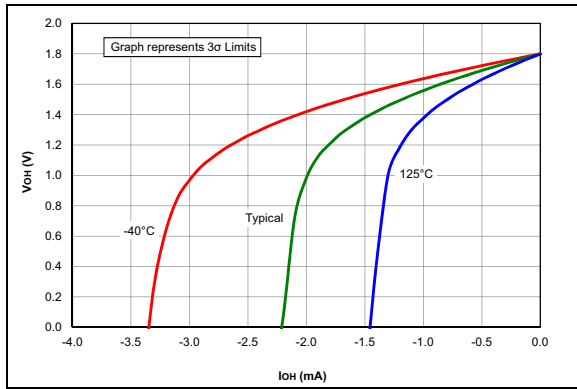
**FIGURE 35-51:**  $V_{OH}$  vs.  $I_{OH}$  Over Temperature,  $V_{DD} = 5.0V$ , PIC16F1717/8/9 Only.



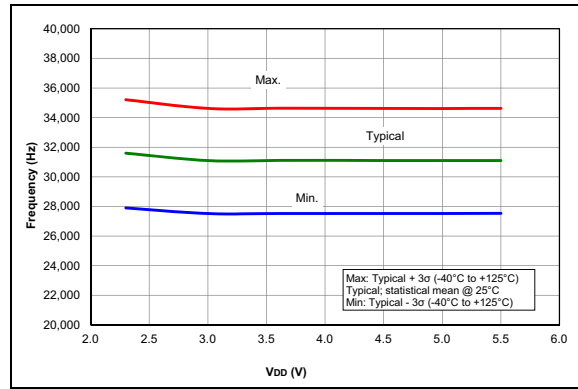
**FIGURE 35-54:**  $V_{OL}$  vs.  $I_{OL}$  Over Temperature,  $V_{DD} = 3.0V$ .

# PIC16(L)F1717/8/9

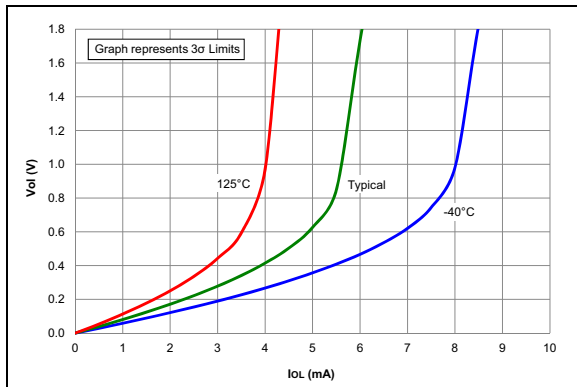
Note: Unless otherwise noted,  $V_{IN} = 5V$ ,  $F_{OSC} = 500\text{ kHz}$ ,  $C_{IN} = 0.1\ \mu\text{F}$ ,  $T_A = 25^\circ\text{C}$ .



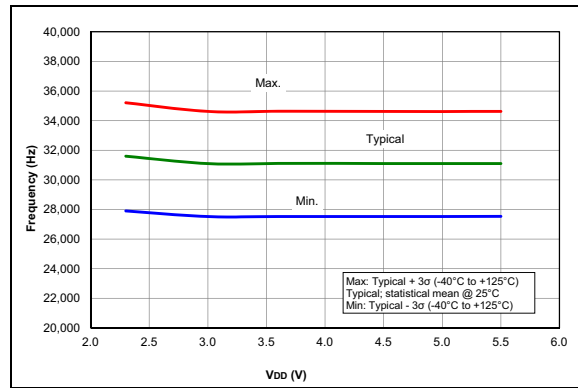
**FIGURE 35-55:**  $V_{OH}$  vs.  $I_{OH}$  Over Temperature,  $V_{DD} = 1.8V$ , PIC16LF1717/8/9 Only.



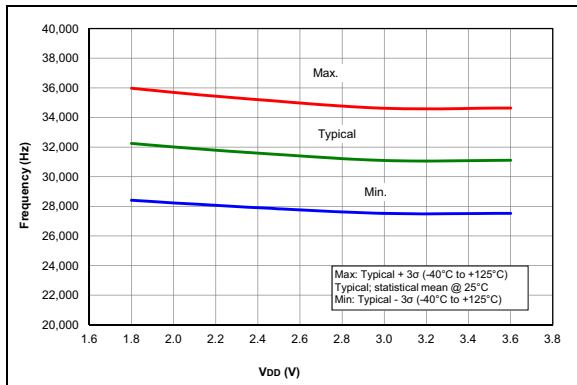
**FIGURE 35-58:** LFINTOSC Frequency, PIC16F1717/8/9 Only.



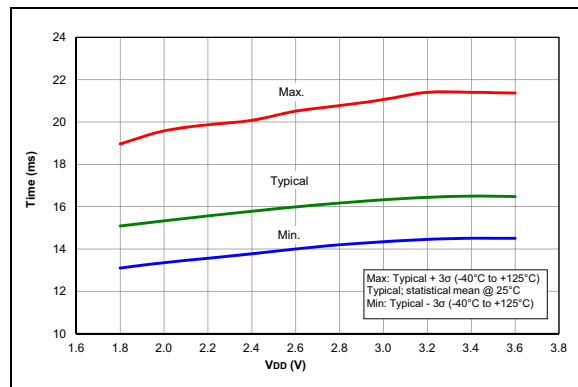
**FIGURE 35-56:**  $V_{OL}$  vs.  $I_{OL}$  Over Temperature,  $V_{DD} = 1.8V$ , PIC16LF1717/8/9 Only.



**FIGURE 35-59:** WDT Time-Out Period, PIC16F1717/8/9 Only.

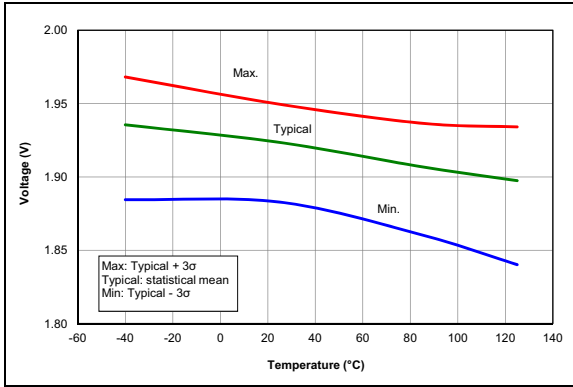


**FIGURE 35-57:** LFINTOSC Frequency, PIC16LF1717/8/9 Only.

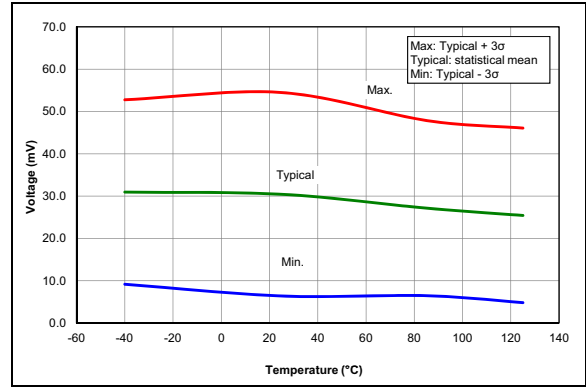


**FIGURE 35-60:** WDT Time-Out Period, PIC16LF1717/8/9 Only.

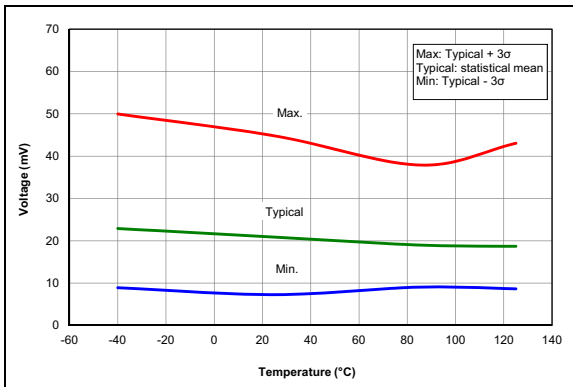
**Note:** Unless otherwise noted,  $V_{IN} = 5V$ ,  $F_{OSC} = 500\text{ kHz}$ ,  $C_{IN} = 0.1\ \mu\text{F}$ ,  $T_A = 25^\circ\text{C}$ .



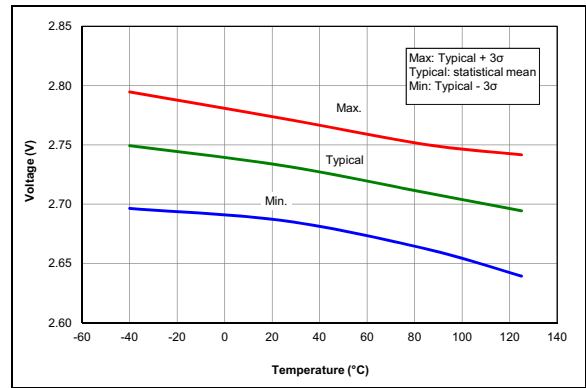
**FIGURE 35-61:** Brown-out Reset Voltage, Low Trip Point ( $BORV = 1$ ), PIC16LF1717/8/9 Only.



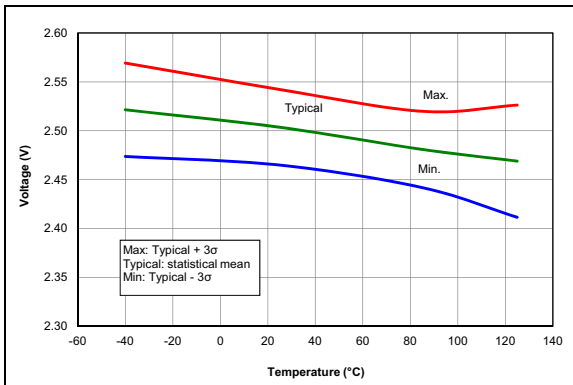
**FIGURE 35-64:** Brown-out Reset Hysteresis, Low Trip Point ( $BORV = 1$ ), PIC16F1717/8/9 Only.



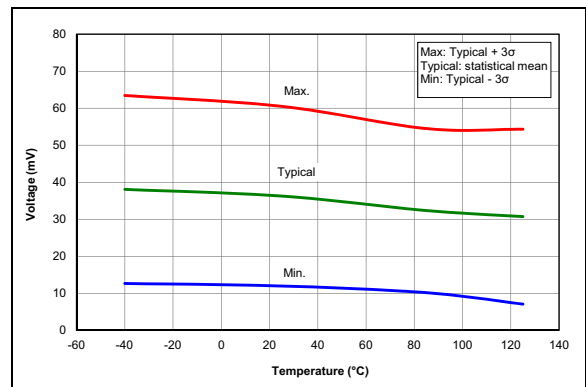
**FIGURE 35-62:** Brown-out Reset Hysteresis, Low Trip Point ( $BORV = 1$ ), PIC16LF1717/8/9 Only.



**FIGURE 35-65:** Brown-out Reset Voltage, High Trip Point ( $BORV = 0$ ).



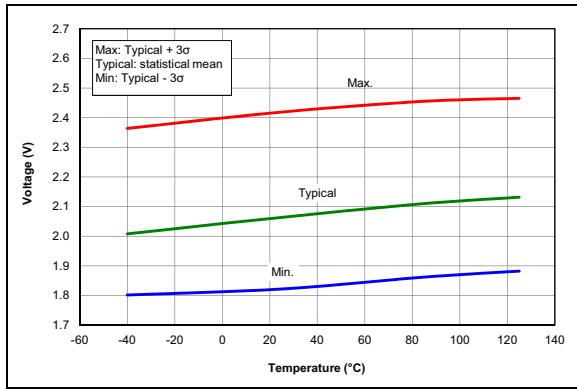
**FIGURE 35-63:** Brown-out Reset Voltage, Low Trip Point ( $BORV = 1$ ), PIC16F1717/8/9 Only.



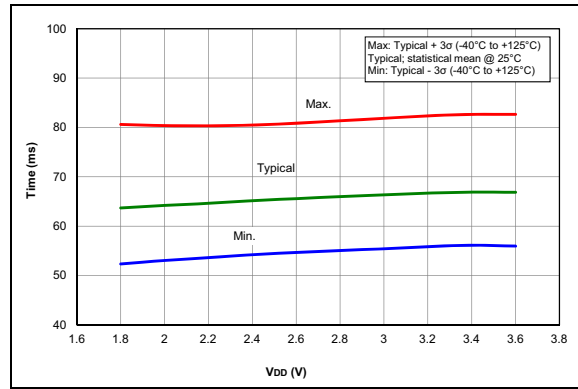
**FIGURE 35-66:** Brown-out Reset Hysteresis, High Trip Point ( $BORV = 0$ ).

# PIC16(L)F1717/8/9

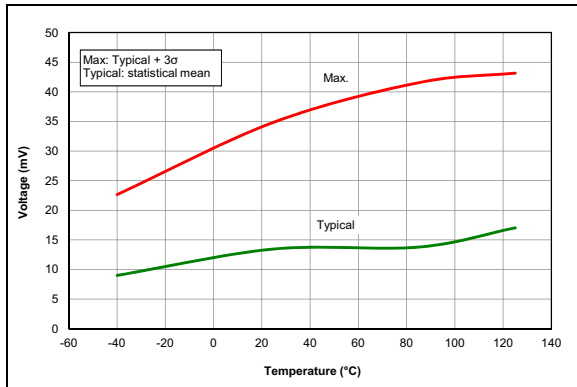
Note: Unless otherwise noted,  $V_{IN} = 5V$ ,  $F_{OSC} = 500\text{ kHz}$ ,  $C_{IN} = 0.1\ \mu F$ ,  $T_A = 25^\circ C$ .



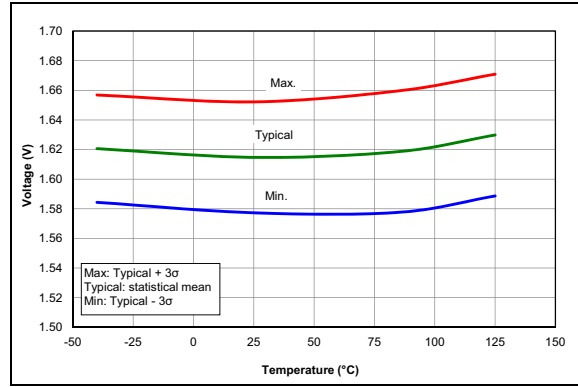
**FIGURE 35-67:** LPBOR Reset Voltage.



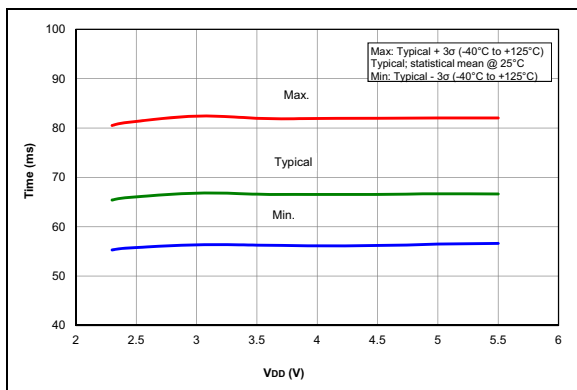
**FIGURE 35-70:** PWRT Period, PIC16LF1717/8/9 Only.



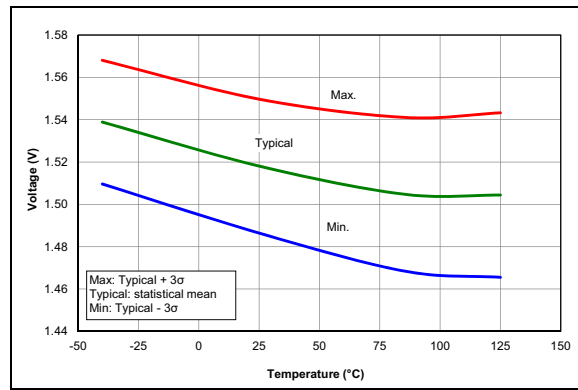
**FIGURE 35-68:** LPBOR Reset Hysteresis.



**FIGURE 35-71:** POR Release Voltage.



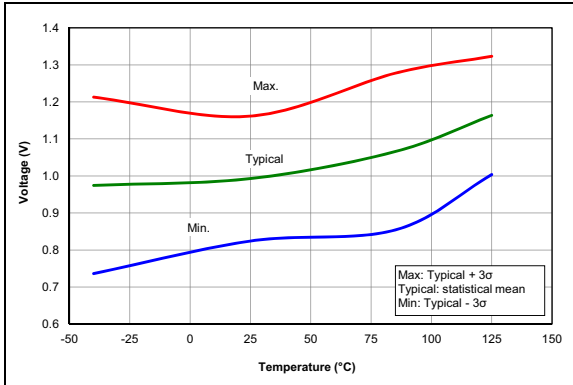
**FIGURE 35-69:** PWRT Period, PIC16F1717/8/9 Only.



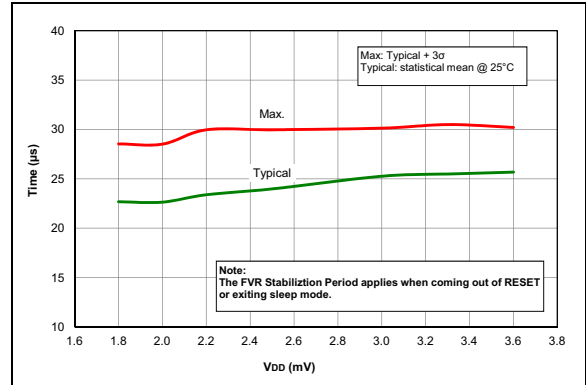
**FIGURE 35-72:** POR Rearm Voltage, NP Mode ( $V_{REGPM1} = 0$ ), PIC16F1717/8/9 Only.

# PIC16(L)F1717/8/9

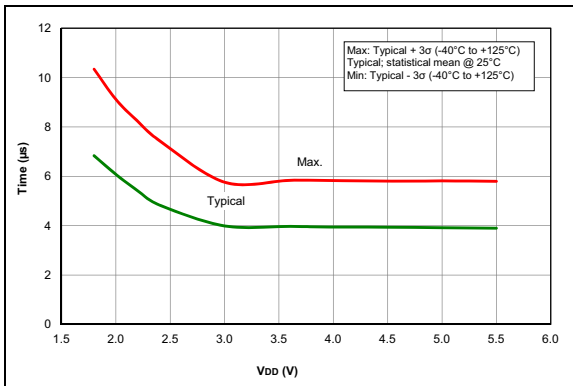
**Note:** Unless otherwise noted,  $V_{IN} = 5V$ ,  $F_{OSC} = 500\text{ kHz}$ ,  $C_{IN} = 0.1\ \mu\text{F}$ ,  $T_A = 25^\circ\text{C}$ .



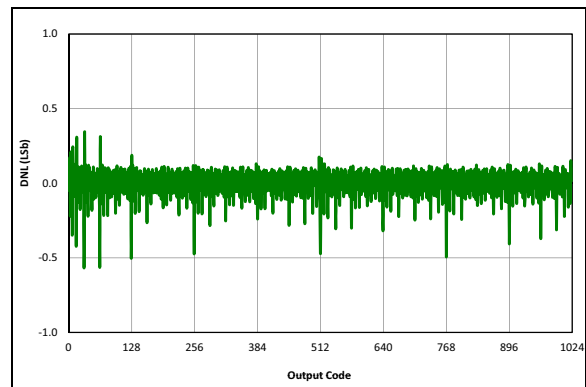
**FIGURE 35-73:** POR Rearm Voltage, NP Mode, PIC16LF1717/8/9 Only.



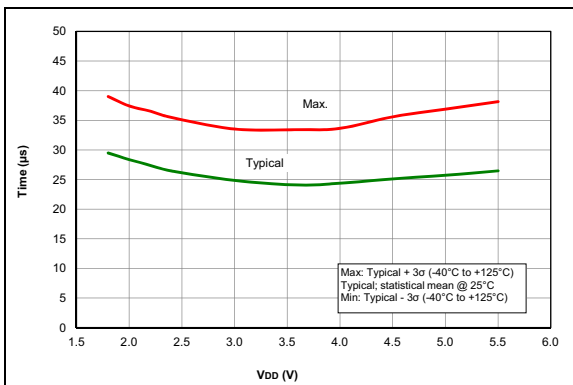
**FIGURE 35-76:** FVR Stabilization Period, PIC16LF1717/8/9 Only.



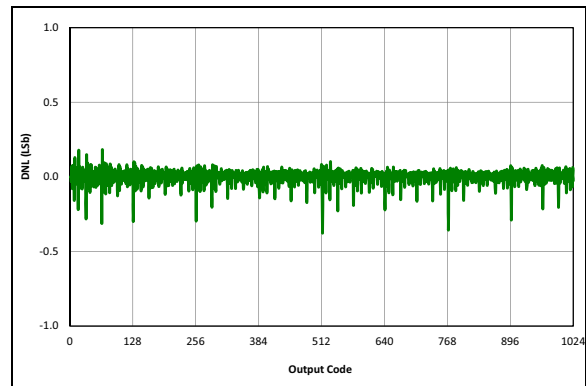
**FIGURE 35-74:** Wake From Sleep,  $V_{REGPM} = 0$ .



**FIGURE 35-77:** ADC 10-bit Mode, Single-Ended DNL,  $V_{DD} = 3.0V$ ,  $T_{AD} = 1\ \mu\text{S}$ ,  $25^\circ\text{C}$ .



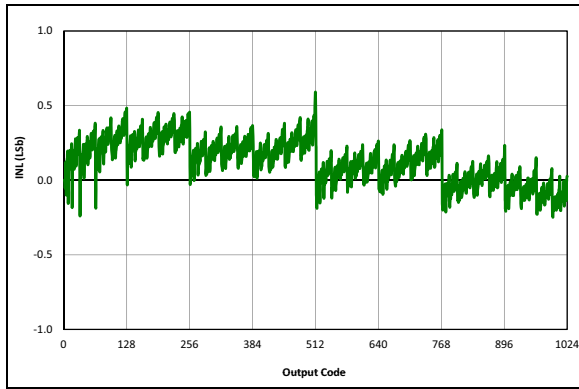
**FIGURE 35-75:** Wake From Sleep,  $V_{REGPM} = 1$ .



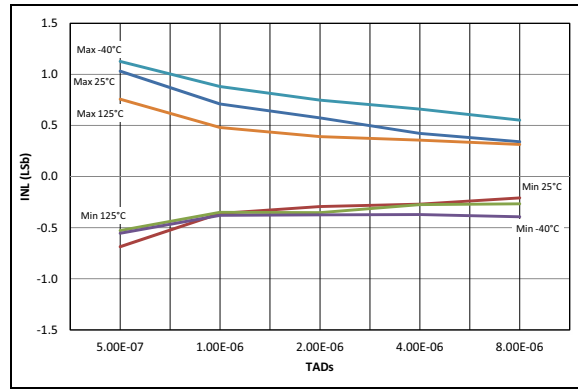
**FIGURE 35-78:** ADC 10-bit Mode, Single-Ended DNL,  $V_{DD} = 3.0V$ ,  $T_{AD} = 4\ \mu\text{S}$ ,  $25^\circ\text{C}$ .

# PIC16(L)F1717/8/9

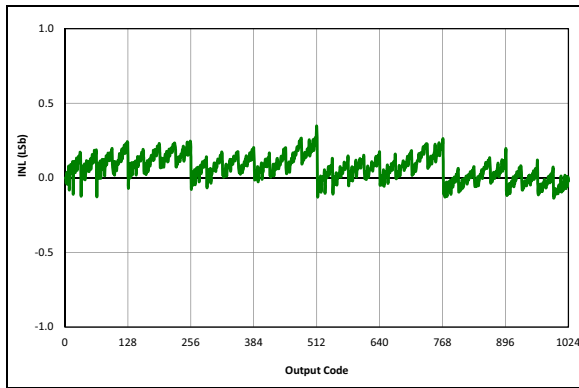
Note: Unless otherwise noted,  $V_{IN} = 5V$ ,  $F_{OSC} = 500\text{ kHz}$ ,  $C_{IN} = 0.1\ \mu\text{F}$ ,  $T_A = 25^\circ\text{C}$ .



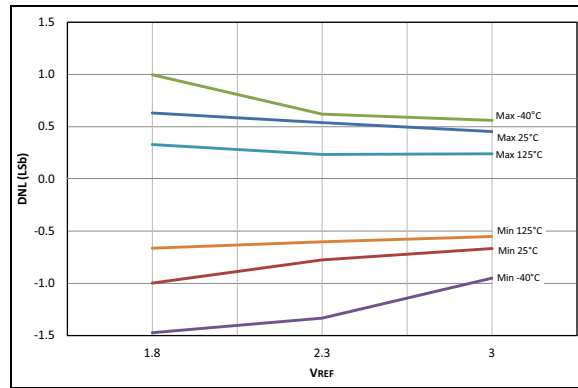
**FIGURE 35-79:** ADC 10-bit Mode, Single-Ended INL,  $V_{DD} = 3.0V$ ,  $T_{AD} = 1\ \mu\text{S}$ ,  $25^\circ\text{C}$ .



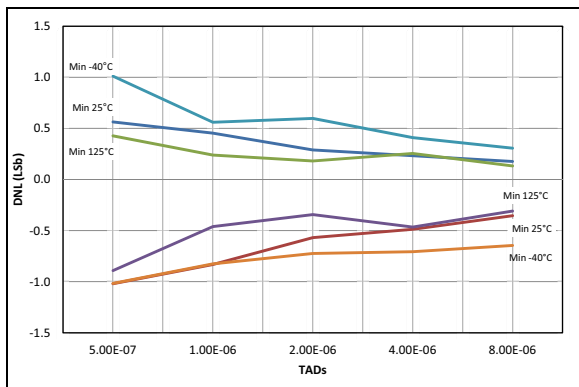
**FIGURE 35-82:** ADC 10-bit Mode, Single-Ended INL,  $V_{DD} = 3.0V$ ,  $V_{REF} = 3.0V$ .



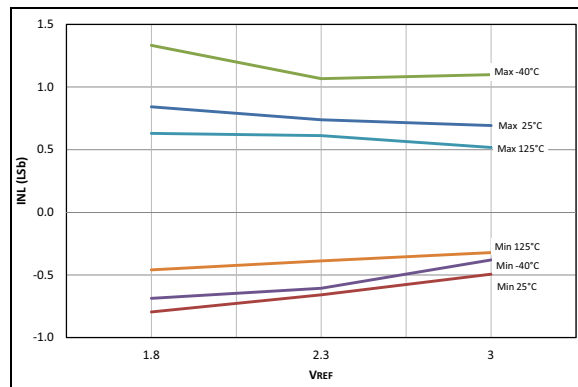
**FIGURE 35-80:** ADC 10-bit Mode, Single-Ended INL,  $V_{DD} = 3.0V$ ,  $T_{AD} = 4\ \mu\text{S}$ ,  $25^\circ\text{C}$ .



**FIGURE 35-83:** ADC 10-bit Mode, Single-Ended DNL,  $V_{DD} = 3.0V$ ,  $T_{AD} = 1\ \mu\text{S}$ .



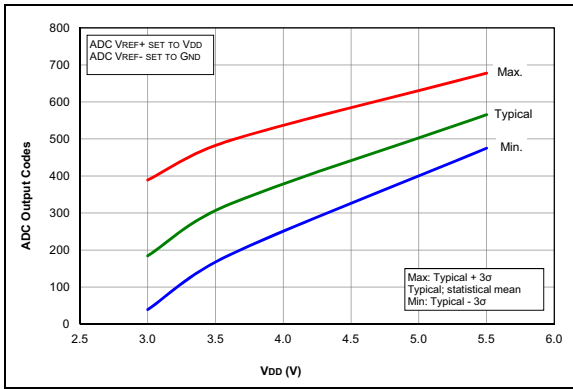
**FIGURE 35-81:** ADC 10-bit Mode, Single-Ended DNL,  $V_{DD} = 3.0V$ ,  $V_{REF} = 3.0V$ .



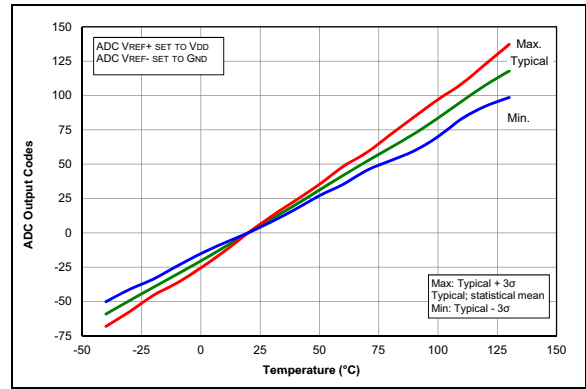
**FIGURE 35-84:** ADC 10-bit Mode, Single-Ended INL,  $V_{DD} = 3.0V$ ,  $T_{AD} = 1\ \mu\text{S}$ .

# PIC16(L)F1717/8/9

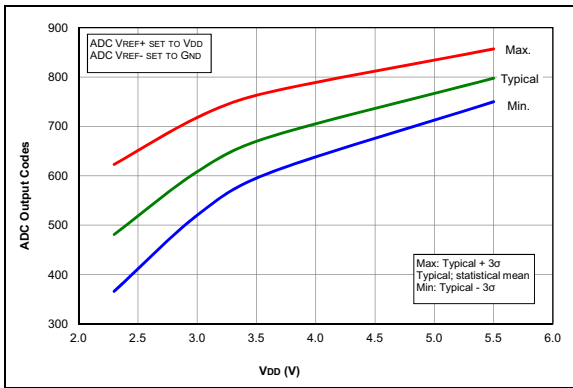
**Note:** Unless otherwise noted,  $V_{IN} = 5V$ ,  $F_{OSC} = 500\text{ kHz}$ ,  $C_{IN} = 0.1\ \mu\text{F}$ ,  $T_A = 25^\circ\text{C}$ .



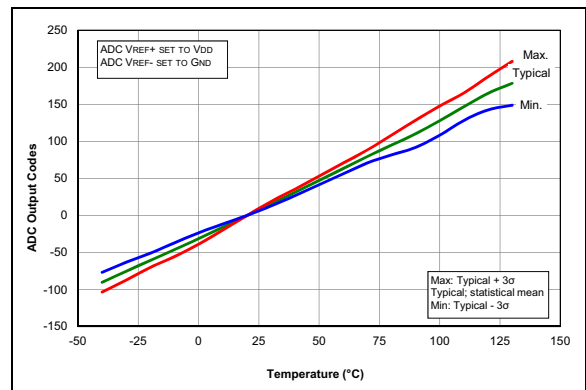
**FIGURE 35-85:** Temp. Indicator Initial Offset, High Range, Temp. = 20°C, PIC16F1717/8/9 Only.



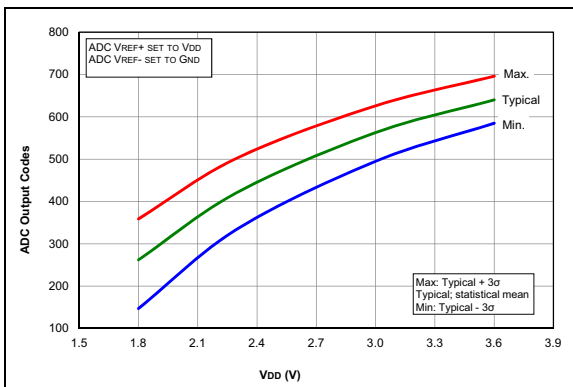
**FIGURE 35-88:** Temp. Indicator Slope Normalized to 20°C, High Range,  $V_{DD} = 5.5V$ , PIC16F1717/8/9 Only.



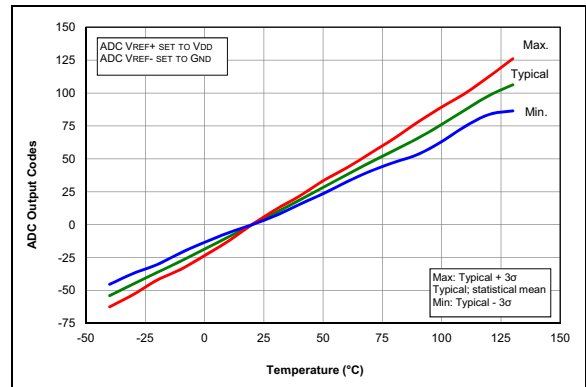
**FIGURE 35-86:** Temp. Indicator Initial Offset, Low Range, Temp. = 20°C, PIC16F1717/8/9 Only.



**FIGURE 35-89:** Temp. Indicator Slope Normalized to 20°C, High Range,  $V_{DD} = 3.0V$ , PIC16F1717/8/9 Only.



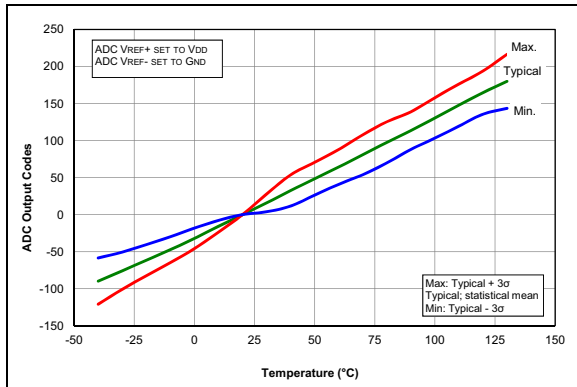
**FIGURE 35-87:** Temp. Indicator Initial Offset, Low Range, Temp. = 20°C, PIC16LF1717/8/9 Only.



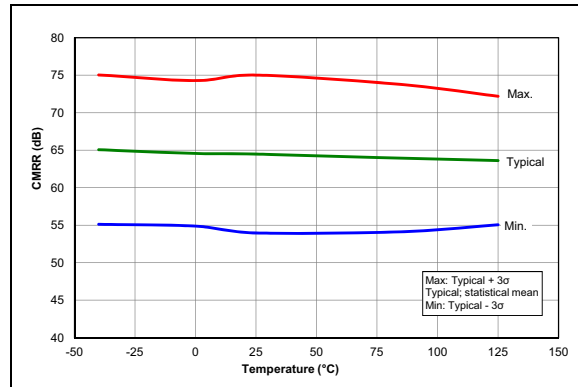
**FIGURE 35-90:** Temp. Indicator Slope Normalized to 20°C, Low Range,  $V_{DD} = 3.0V$ , PIC16F1717/8/9 Only.

# PIC16(L)F1717/8/9

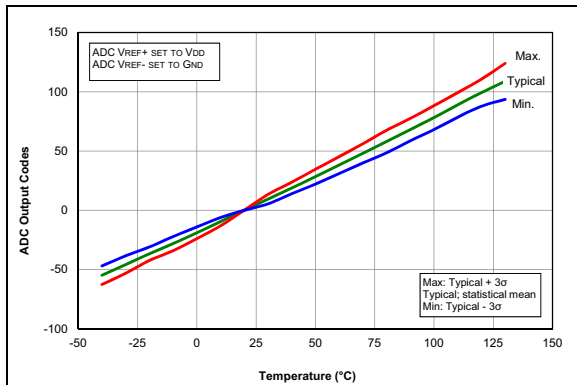
Note: Unless otherwise noted,  $V_{IN} = 5V$ ,  $F_{OSC} = 500\text{ kHz}$ ,  $C_{IN} = 0.1\ \mu F$ ,  $T_A = 25^\circ C$ .



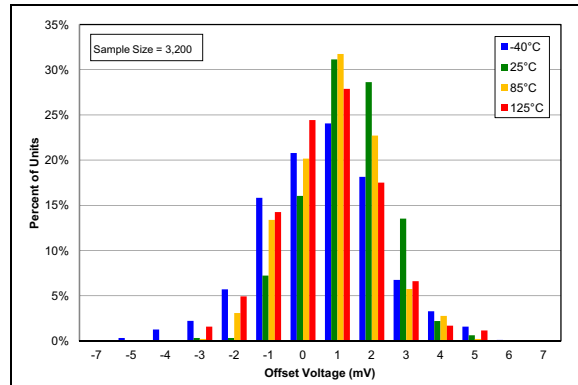
**FIGURE 35-91:** Temp. Indicator Slope Normalized to  $20^\circ C$ , Low Range,  $V_{DD} = 1.8V$ , PIC16LF1717/8/9 Only.



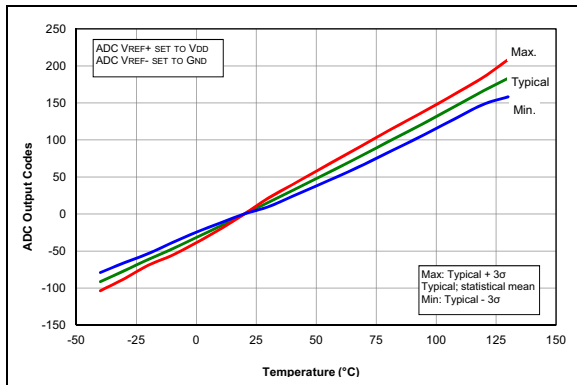
**FIGURE 35-94:** Op Amp, Common Mode Rejection Ratio (CMRR),  $V_{DD} = 3.0V$ .



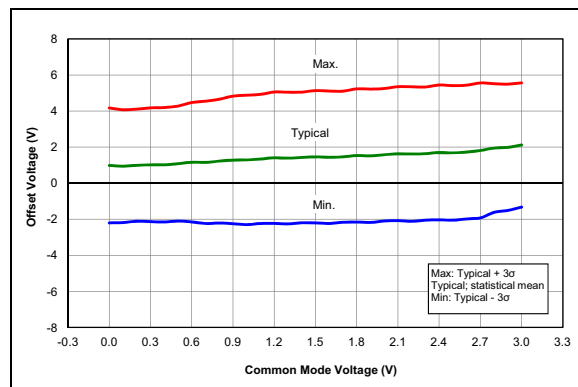
**FIGURE 35-92:** Temp. Indicator Slope Normalized to  $20^\circ C$ , Low Range,  $V_{DD} = 3.0V$ , PIC16LF1717/8/9 Only.



**FIGURE 35-95:** Op Amp, Output Voltage Histogram,  $V_{DD} = 3.0V$ ,  $V_{CM} = V_{DD}/2$ .



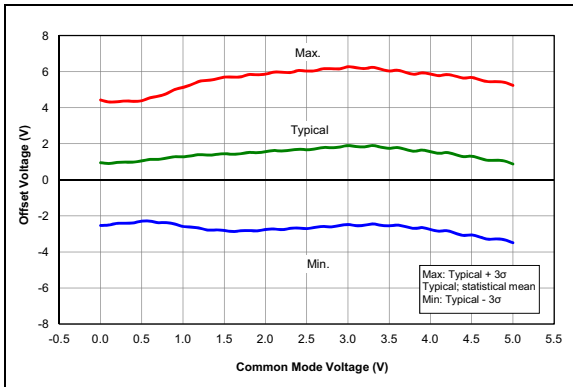
**FIGURE 35-93:** Temp. Indicator Slope Normalized to  $20^\circ C$ , High Range,  $V_{DD} = 3.6V$ , PIC16LF1717/8/9 Only.



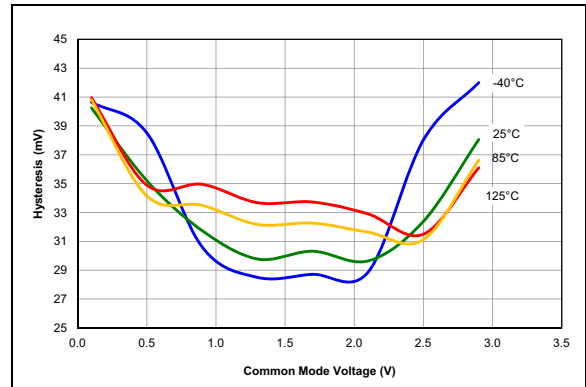
**FIGURE 35-96:** Op Amp, Offset Over Common Mode Voltage,  $V_{DD} = 3.0V$ ,  $Temp. = 25^\circ C$ .



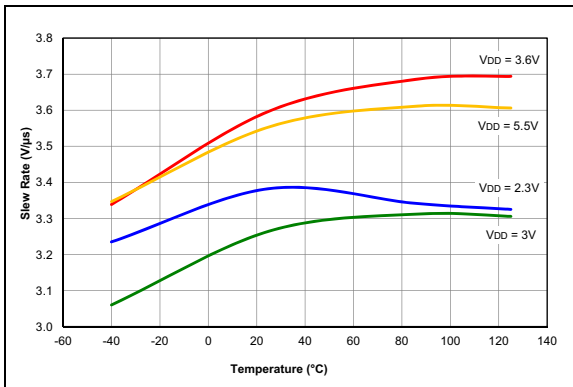
**Note:** Unless otherwise noted,  $V_{IN} = 5V$ ,  $F_{OSC} = 500\text{ kHz}$ ,  $C_{IN} = 0.1\ \mu\text{F}$ ,  $T_A = 25^\circ\text{C}$ .



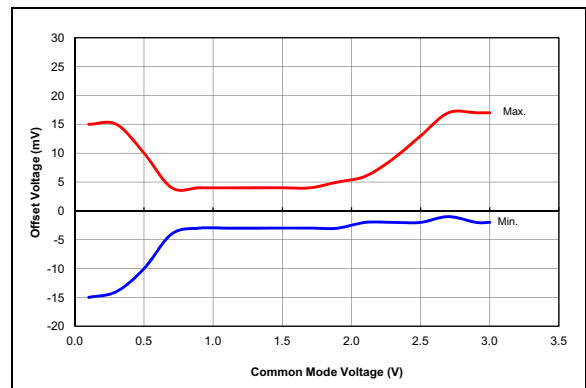
**FIGURE 35-97:** Op Amp, Offset Over Common Mode Voltage,  $V_{DD} = 5.0V$ , Temp. =  $25^\circ\text{C}$ , PIC16F1717/8/9 Only.



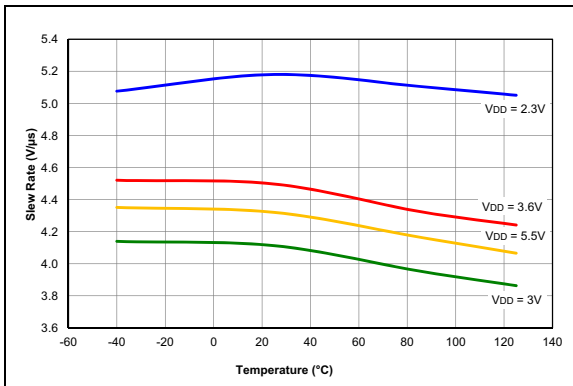
**FIGURE 35-100:** Comparator Hysteresis, NP Mode ( $CxSP = 1$ ),  $V_{DD} = 3.0V$ , Typical Measured Values.



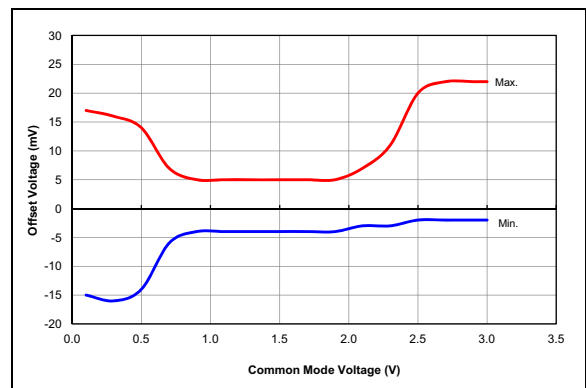
**FIGURE 35-98:** Op Amp, Output Slew Rate, Rising Edge, PIC16F1717/8/9 Only.



**FIGURE 35-101:** Comparator Offset, NP Mode ( $CxSP = 1$ ),  $V_{DD} = 3.0V$ , Typical Measured Values at  $25^\circ\text{C}$ .



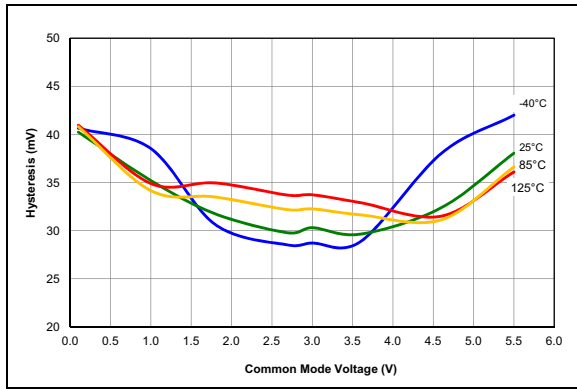
**FIGURE 35-99:** Op Amp, Output Slew Rate, Falling Edge, PIC16F1717/8/9 Only.



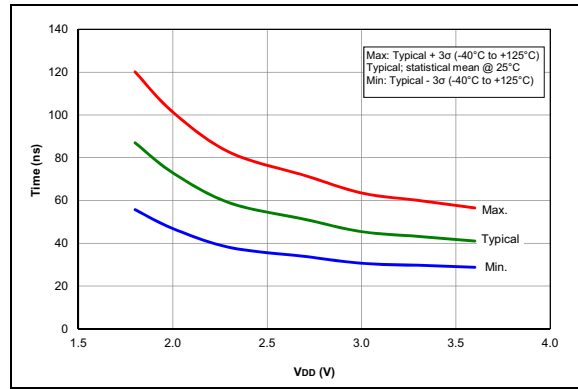
**FIGURE 35-102:** Comparator Offset, NP Mode ( $CxSP = 1$ ),  $V_{DD} = 3.0V$ , Typical Measured Values From  $-40^\circ\text{C}$  to  $125^\circ\text{C}$ .

# PIC16(L)F1717/8/9

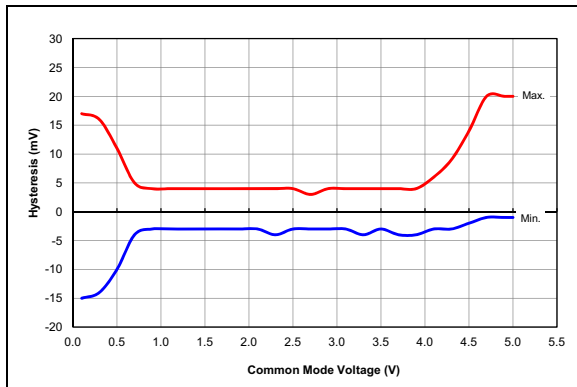
Note: Unless otherwise noted,  $V_{IN} = 5V$ ,  $F_{OSC} = 500\text{ kHz}$ ,  $C_{IN} = 0.1\ \mu\text{F}$ ,  $T_A = 25^\circ\text{C}$ .



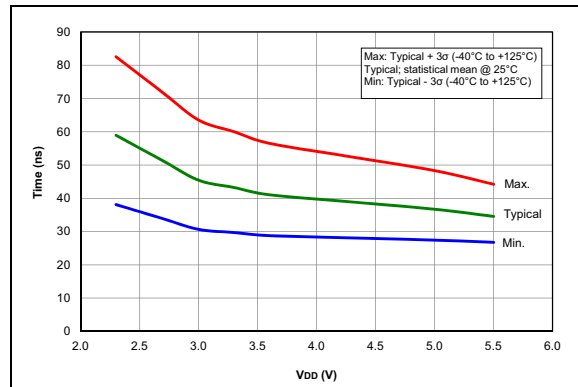
**FIGURE 35-103:** Comparator Hysteresis, NP Mode ( $CxSP = 1$ ),  $V_{DD} = 5.5V$ , Typical Measured Values, PIC16F1717/8/9 Only.



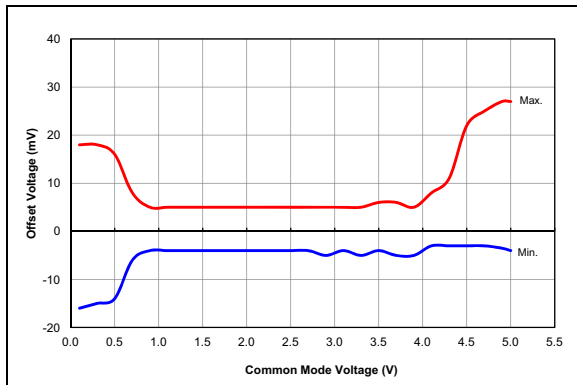
**FIGURE 35-106:** Comparator Response Time Over Voltage, NP Mode ( $CxSP = 1$ ), Typical Measured Values, PIC16LF1717/8/9 Only.



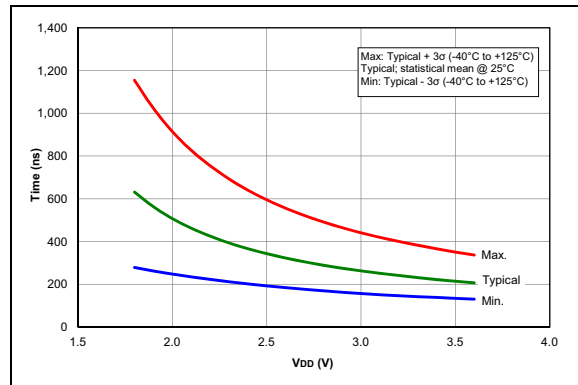
**FIGURE 35-104:** Comparator Offset, NP Mode ( $CxSP = 1$ ),  $V_{DD} = 5.0V$ , Typical Measured Values at  $25^\circ\text{C}$ , PIC16F1717/8/9 Only.



**FIGURE 35-107:** Comparator Response Time Over Voltage, NP Mode ( $CxSP = 1$ ), Typical Measured Values, PIC16F1717/8/9 Only.

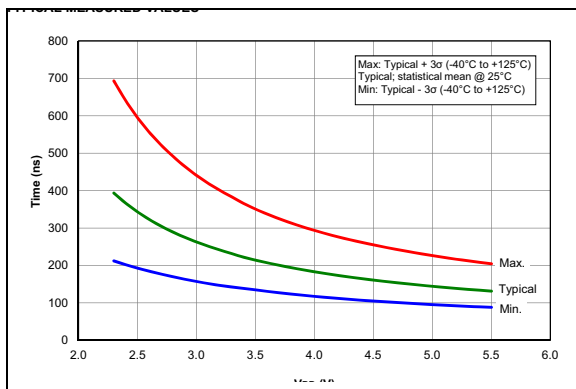


**FIGURE 35-105:** Comparator Offset, NP Mode ( $CxSP = 1$ ),  $V_{DD} = 5.5V$ , Typical Measured Values From  $-40^\circ\text{C}$  to  $125^\circ\text{C}$ , PIC16F1717/8/9 Only.

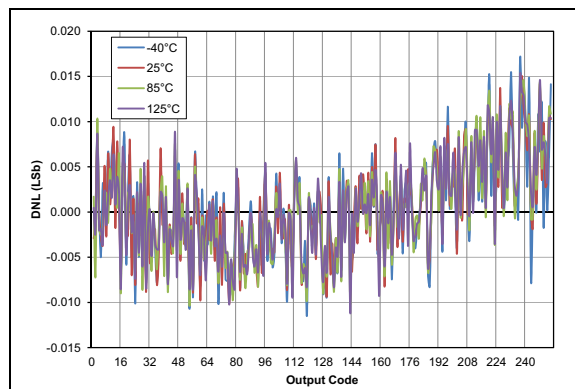


**FIGURE 35-108:** Comparator Output Filter Delay Time Over Temp., NP Mode ( $CxSP = 1$ ), Typical Measured Values, PIC16LF1717/8/9 Only.

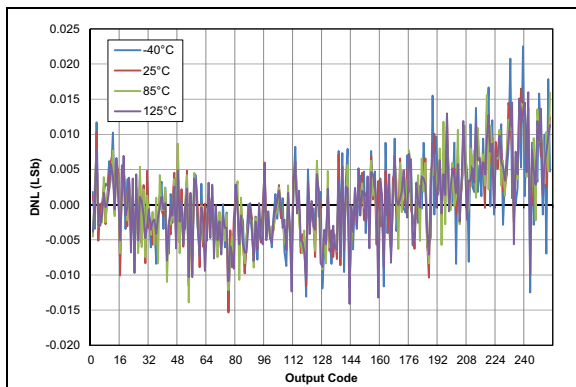
**Note:** Unless otherwise noted,  $V_{IN} = 5V$ ,  $F_{OSC} = 500\text{ kHz}$ ,  $C_{IN} = 0.1\ \mu\text{F}$ ,  $T_A = 25^\circ\text{C}$ .



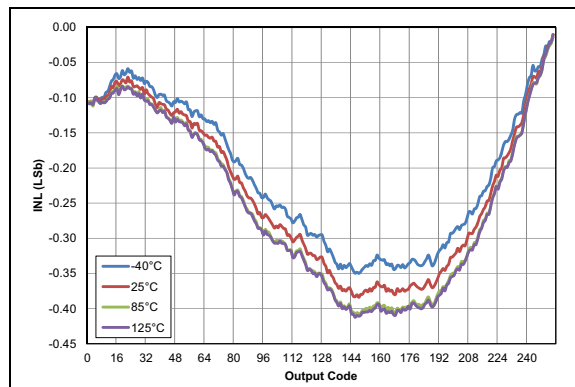
**FIGURE 35-109:** Comparator Output Filter Delay Time Over Temp., NP Mode ( $CxSP = 1$ ), Typical Measured Values, PIC16F1717/8/9 Only.



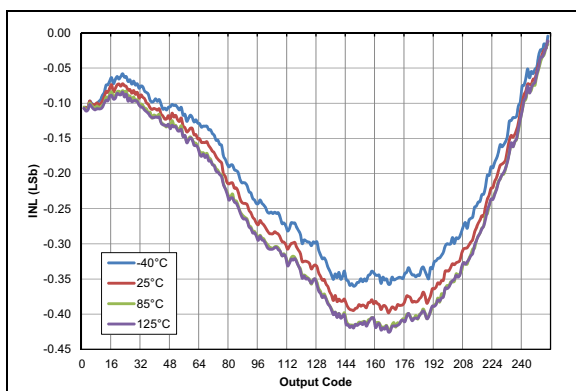
**FIGURE 35-112:** Typical DAC INL Error,  $V_{DD} = 5.0V$ ,  $V_{REF} = \text{External } 5V$ , PIC16F1717/8/9 Only.



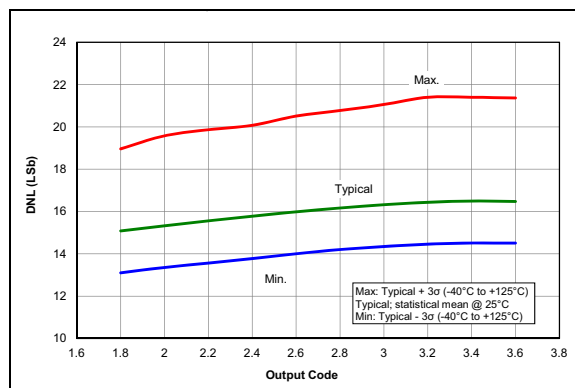
**FIGURE 35-110:** Typical DAC DNL Error,  $V_{DD} = 3.0V$ ,  $V_{REF} = \text{External } 3V$ .



**FIGURE 35-113:** Typical DAC INL Error,  $V_{DD} = 5.0V$ ,  $V_{REF} = \text{External } 5V$ , PIC16F1717/8/9 Only.



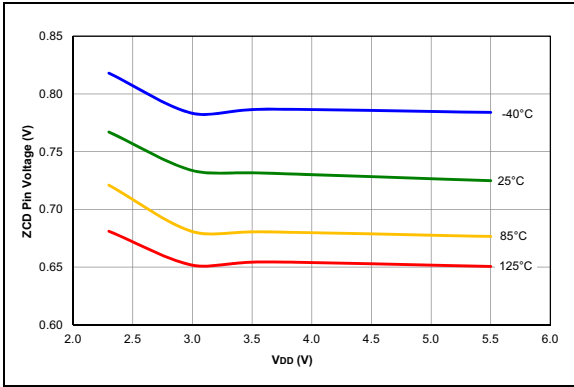
**FIGURE 35-111:** Typical DAC INL Error,  $V_{DD} = 3.0V$ ,  $V_{REF} = \text{External } 3V$ .



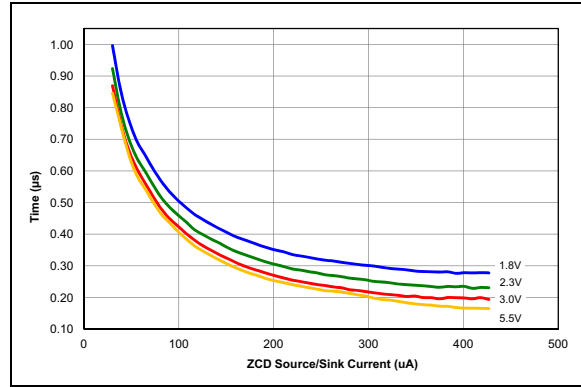
**FIGURE 35-114:** DAC INL Error,  $V_{DD} = 3.0V$ , PIC16LF1717/8/9 Only.

# PIC16(L)F1717/8/9

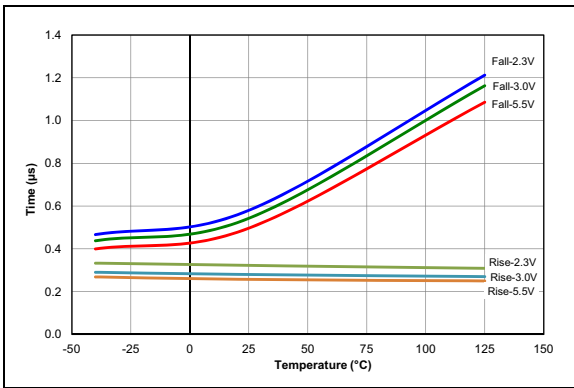
**Note:** Unless otherwise noted,  $V_{IN} = 5V$ ,  $F_{OSC} = 500\text{ kHz}$ ,  $C_{IN} = 0.1\ \mu F$ ,  $T_A = 25^\circ C$ .



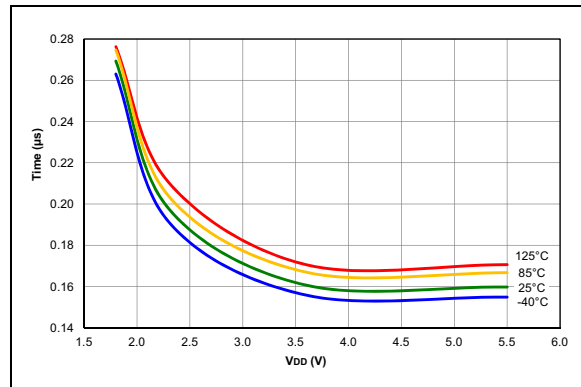
**FIGURE 35-115:** ZCD Pin Voltage, Typical Measured Values



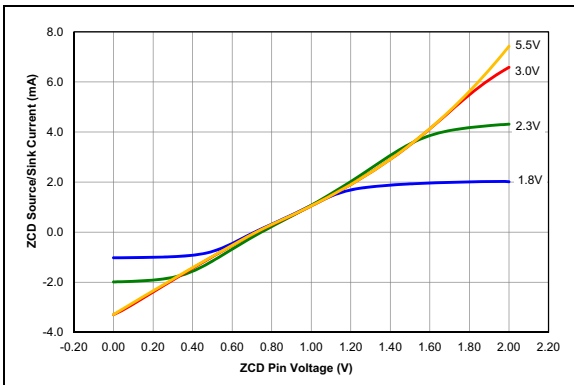
**FIGURE 35-118:** ZCD Pin Response Time Over Current, Typical Measured Values From  $-40^\circ C$  to  $125^\circ C$ .



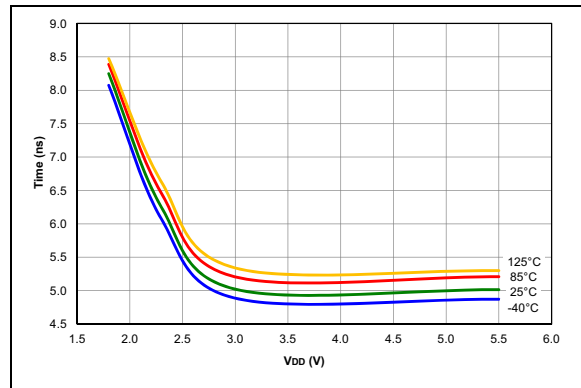
**FIGURE 35-116:** ZCD Response Time Over Voltage, Typical Measured Values.



**FIGURE 35-119:** COG Dead-Band Delay,  $DBR/DBF = 32$ , Typical Measured Values

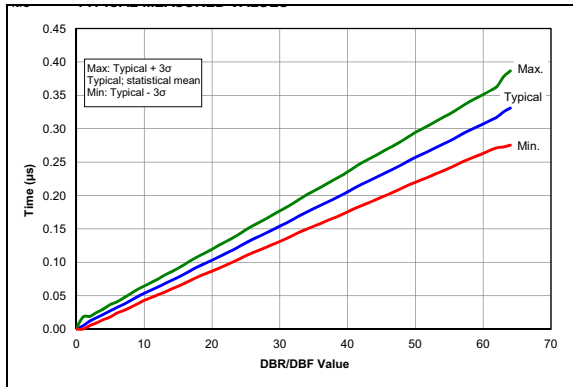


**FIGURE 35-117:** ZCD Pin Current Over ZCD Pin Voltage, Typical Measured Values From  $-40^\circ C$  to  $125^\circ C$ .

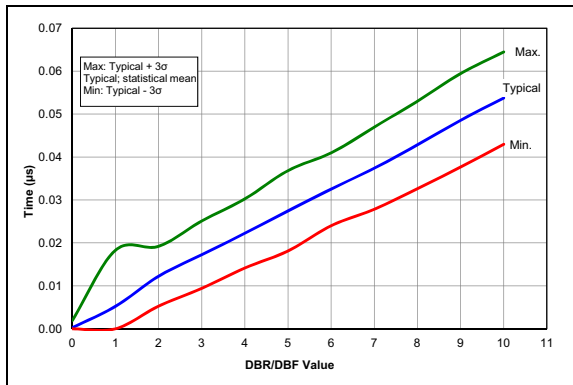


**FIGURE 35-120:** COG Dead-Band DBR/DBF Delay Per Step, Typical Measured Values.

**Note:** Unless otherwise noted,  $V_{IN} = 5V$ ,  $F_{OSC} = 500\text{ kHz}$ ,  $C_{IN} = 0.1\ \mu F$ ,  $T_A = 25^\circ C$ .



**FIGURE 35-121:** COG Dead Band Delay Per Step, Typical Measured Values



**FIGURE 35-122:** COG Dead Band Delay Per Step, Zoomed to First 10 Codes, Typical Measured Values.

## 36.0 DEVELOPMENT SUPPORT

The PIC microcontrollers (MCU) and dsPIC® digital signal controllers (DSC) are supported with a full range of software and hardware development tools:

- Integrated Development Environment
  - MPLAB® X IDE Software
- Compilers/Assemblers/Linkers
  - MPLAB XC Compiler
  - MPASM™ Assembler
  - MPLINK™ Object Linker/  
MPLIB™ Object Librarian
  - MPLAB Assembler/Linker/Librarian for  
Various Device Families
- Simulators
  - MPLAB X SIM Software Simulator
- Emulators
  - MPLAB REAL ICE™ In-Circuit Emulator
- In-Circuit Debuggers/Programmers
  - MPLAB ICD 3
  - PICKit 3
- Device Programmers
  - MPLAB PM3 Device Programmer
- Low-Cost Demonstration/Development Boards,  
Evaluation Kits and Starter Kits
- Third-party development tools

## 36.1 MPLAB X Integrated Development Environment Software

The MPLAB X IDE is a single, unified graphical user interface for Microchip and third-party software, and hardware development tool that runs on Windows®, Linux and Mac OS® X. Based on the NetBeans IDE, MPLAB X IDE is an entirely new IDE with a host of free software components and plug-ins for high-performance application development and debugging. Moving between tools and upgrading from software simulators to hardware debugging and programming tools is simple with the seamless user interface.

With complete project management, visual call graphs, a configurable watch window and a feature-rich editor that includes code completion and context menus, MPLAB X IDE is flexible and friendly enough for new users. With the ability to support multiple tools on multiple projects with simultaneous debugging, MPLAB X IDE is also suitable for the needs of experienced users.

Feature-Rich Editor:

- Color syntax highlighting
- Smart code completion makes suggestions and provides hints as you type
- Automatic code formatting based on user-defined rules
- Live parsing

User-Friendly, Customizable Interface:

- Fully customizable interface: toolbars, toolbar buttons, windows, window placement, etc.
- Call graph window

Project-Based Workspaces:

- Multiple projects
- Multiple tools
- Multiple configurations
- Simultaneous debugging sessions

File History and Bug Tracking:

- Local file history feature
- Built-in support for Bugzilla issue tracker

## 36.2 MPLAB XC Compilers

The MPLAB XC Compilers are complete ANSI C compilers for all of Microchip's 8, 16, and 32-bit MCU and DSC devices. These compilers provide powerful integration capabilities, superior code optimization and ease of use. MPLAB XC Compilers run on Windows, Linux or MAC OS X.

For easy source level debugging, the compilers provide debug information that is optimized to the MPLAB X IDE.

The free MPLAB XC Compiler editions support all devices and commands, with no time or memory restrictions, and offer sufficient code optimization for most applications.

MPLAB XC Compilers include an assembler, linker and utilities. The assembler generates relocatable object files that can then be archived or linked with other relocatable object files and archives to create an executable file. MPLAB XC Compiler uses the assembler to produce its object file. Notable features of the assembler include:

- Support for the entire device instruction set
- Support for fixed-point and floating-point data
- Command-line interface
- Rich directive set
- Flexible macro language
- MPLAB X IDE compatibility

## 36.3 MPASM Assembler

The MPASM Assembler is a full-featured, universal macro assembler for PIC10/12/16/18 MCUs.

The MPASM Assembler generates relocatable object files for the MPLINK Object Linker, Intel® standard HEX files, MAP files to detail memory usage and symbol reference, absolute LST files that contain source lines and generated machine code, and COFF files for debugging.

The MPASM Assembler features include:

- Integration into MPLAB X IDE projects
- User-defined macros to streamline assembly code
- Conditional assembly for multipurpose source files
- Directives that allow complete control over the assembly process

## 36.4 MPLINK Object Linker/ MPLIB Object Librarian

The MPLINK Object Linker combines relocatable objects created by the MPASM Assembler. It can link relocatable objects from precompiled libraries, using directives from a linker script.

The MPLIB Object Librarian manages the creation and modification of library files of precompiled code. When a routine from a library is called from a source file, only the modules that contain that routine will be linked in with the application. This allows large libraries to be used efficiently in many different applications.

The object linker/librarian features include:

- Efficient linking of single libraries instead of many smaller files
- Enhanced code maintainability by grouping related modules together
- Flexible creation of libraries with easy module listing, replacement, deletion and extraction

## 36.5 MPLAB Assembler, Linker and Librarian for Various Device Families

MPLAB Assembler produces relocatable machine code from symbolic assembly language for PIC24, PIC32 and dsPIC DSC devices. MPLAB XC Compiler uses the assembler to produce its object file. The assembler generates relocatable object files that can then be archived or linked with other relocatable object files and archives to create an executable file. Notable features of the assembler include:

- Support for the entire device instruction set
- Support for fixed-point and floating-point data
- Command-line interface
- Rich directive set
- Flexible macro language
- MPLAB X IDE compatibility

## 36.6 MPLAB X SIM Software Simulator

The MPLAB X SIM Software Simulator allows code development in a PC-hosted environment by simulating the PIC MCUs and dsPIC DSCs on an instruction level. On any given instruction, the data areas can be examined or modified and stimuli can be applied from a comprehensive stimulus controller. Registers can be logged to files for further run-time analysis. The trace buffer and logic analyzer display extend the power of the simulator to record and track program execution, actions on I/O, most peripherals and internal registers.

The MPLAB X SIM Software Simulator fully supports symbolic debugging using the MPLAB XC Compilers, and the MPASM and MPLAB Assemblers. The software simulator offers the flexibility to develop and debug code outside of the hardware laboratory environment, making it an excellent, economical software development tool.

## 36.7 MPLAB REAL ICE In-Circuit Emulator System

The MPLAB REAL ICE In-Circuit Emulator System is Microchip's next generation high-speed emulator for Microchip Flash DSC and MCU devices. It debugs and programs all 8, 16 and 32-bit MCU, and DSC devices with the easy-to-use, powerful graphical user interface of the MPLAB X IDE.

The emulator is connected to the design engineer's PC using a high-speed USB 2.0 interface and is connected to the target with either a connector compatible with in-circuit debugger systems (RJ-11) or with the new high-speed, noise tolerant, Low-Voltage Differential Signal (LVDS) interconnection (CAT5).

The emulator is field upgradeable through future firmware downloads in MPLAB X IDE. MPLAB REAL ICE offers significant advantages over competitive emulators including full-speed emulation, run-time variable watches, trace analysis, complex breakpoints, logic probes, a ruggedized probe interface and long (up to three meters) interconnection cables.

## 36.8 MPLAB ICD 3 In-Circuit Debugger System

The MPLAB ICD 3 In-Circuit Debugger System is Microchip's most cost-effective, high-speed hardware debugger/programmer for Microchip Flash DSC and MCU devices. It debugs and programs PIC Flash microcontrollers and dsPIC DSCs with the powerful, yet easy-to-use graphical user interface of the MPLAB IDE.

The MPLAB ICD 3 In-Circuit Debugger probe is connected to the design engineer's PC using a high-speed USB 2.0 interface and is connected to the target with a connector compatible with the MPLAB ICD 2 or MPLAB REAL ICE systems (RJ-11). MPLAB ICD 3 supports all MPLAB ICD 2 headers.

## 36.9 PICkit 3 In-Circuit Debugger/Programmer

The MPLAB PICkit 3 allows debugging and programming of PIC and dsPIC Flash microcontrollers at a most affordable price point using the powerful graphical user interface of the MPLAB IDE. The MPLAB PICkit 3 is connected to the design engineer's PC using a full-speed USB interface and can be connected to the target via a Microchip debug (RJ-11) connector (compatible with MPLAB ICD 3 and MPLAB REAL ICE). The connector uses two device I/O pins and the Reset line to implement in-circuit debugging and In-Circuit Serial Programming™ (ICSP™).

## 36.10 MPLAB PM3 Device Programmer

The MPLAB PM3 Device Programmer is a universal, CE compliant device programmer with programmable voltage verification at VDDMIN and VDDMAX for maximum reliability. It features a large LCD display (128 x 64) for menus and error messages, and a modular, detachable socket assembly to support various package types. The ICSP cable assembly is included as a standard item. In Stand-Alone mode, the MPLAB PM3 Device Programmer can read, verify and program PIC devices without a PC connection. It can also set code protection in this mode. The MPLAB PM3 connects to the host PC via an RS-232 or USB cable. The MPLAB PM3 has high-speed communications and optimized algorithms for quick programming of large memory devices, and incorporates an MMC card for file storage and data applications.



## 36.11 Demonstration/Development Boards, Evaluation Kits, and Starter Kits

A wide variety of demonstration, development and evaluation boards for various PIC MCUs and dsPIC DSCs allows quick application development on fully functional systems. Most boards include prototyping areas for adding custom circuitry and provide application firmware and source code for examination and modification.

The boards support a variety of features, including LEDs, temperature sensors, switches, speakers, RS-232 interfaces, LCD displays, potentiometers and additional EEPROM memory.

The demonstration and development boards can be used in teaching environments, for prototyping custom circuits and for learning about various microcontroller applications.

In addition to the PICDEM™ and dsPICDEM™ demonstration/development board series of circuits, Microchip has a line of evaluation kits and demonstration software for analog filter design, KEELOQ® security ICs, CAN, IrDA®, PowerSmart battery management, SEEVAL® evaluation system, Sigma-Delta ADC, flow rate sensing, plus many more.

Also available are starter kits that contain everything needed to experience the specified device. This usually includes a single application and debug capability, all on one board.

Check the Microchip web page ([www.microchip.com](http://www.microchip.com)) for the complete list of demonstration, development and evaluation kits.

## 36.12 Third-Party Development Tools

Microchip also offers a great collection of tools from third-party vendors. These tools are carefully selected to offer good value and unique functionality.

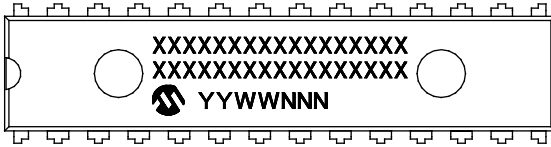
- Device Programmers and Gang Programmers from companies, such as SoftLog and CCS
- Software Tools from companies, such as Gimpel and Trace Systems
- Protocol Analyzers from companies, such as Saleae and Total Phase
- Demonstration Boards from companies, such as MikroElektronika, Digilent® and Olimex
- Embedded Ethernet Solutions from companies, such as EZ Web Lynx, WIZnet and IPLogika®

# PIC16(L)F1717/8/9

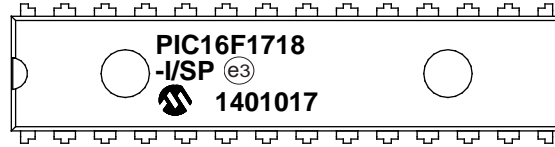
## 37.0 PACKAGING INFORMATION

### 37.1 Package Marking Information

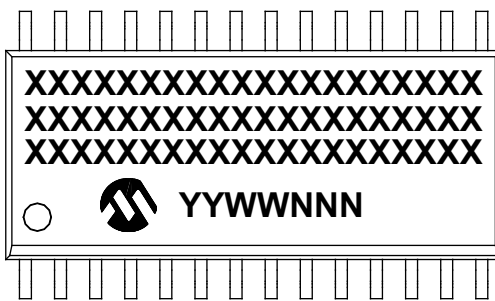
28-Lead SPDIP (.300")



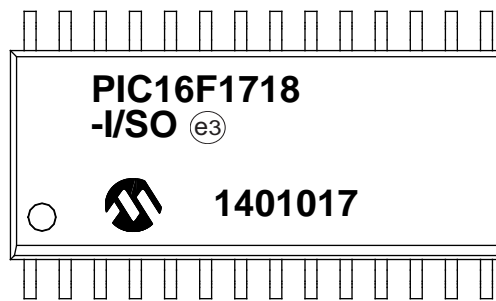
Example



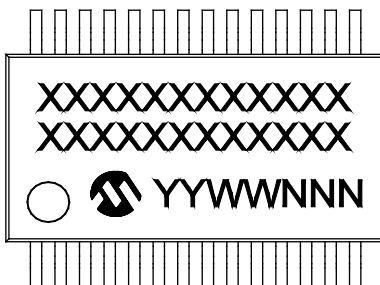
28-Lead SOIC (7.50 mm)



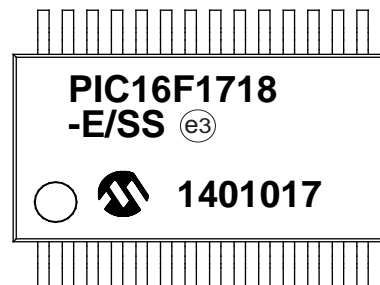
Example



28-Lead SSOP (5.30 mm)



Example

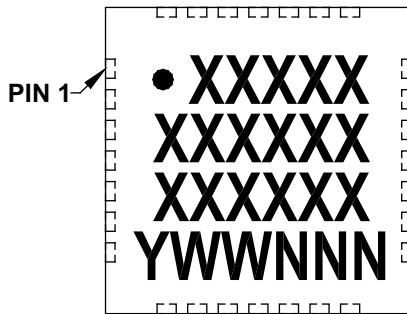


<b>Legend:</b>	XX...X	Customer-specific information
	Y	Year code (last digit of calendar year)
	YY	Year code (last 2 digits of calendar year)
	WW	Week code (week of January 1 is week '01')
	NNN	Alphanumeric traceability code
	(e3)	Pb-free JEDEC® designator for Matte Tin (Sn)
	*	This package is Pb-free. The Pb-free JEDEC designator (e3) can be found on the outer packaging for this package.

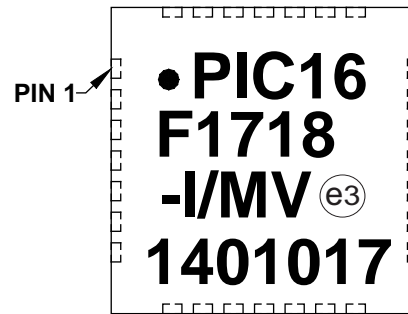
**Note:** In the event the full Microchip part number cannot be marked on one line, it will be carried over to the next line, thus limiting the number of available characters for customer-specific information.

## Package Marking Information (Continued)

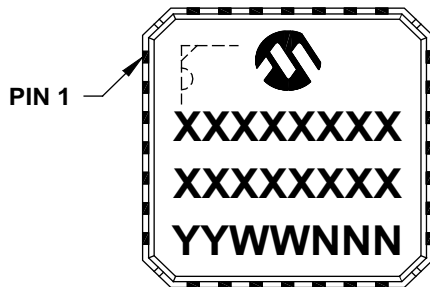
28-Lead UQFN (4x4x0.5 mm)



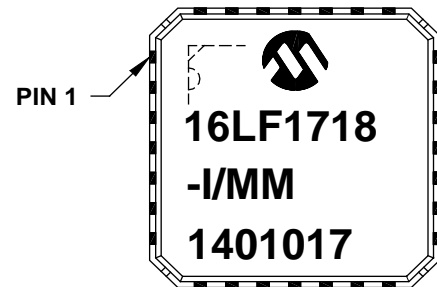
Example



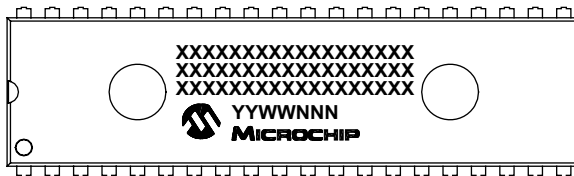
28-Lead QFN (6x6x0.9 mm)



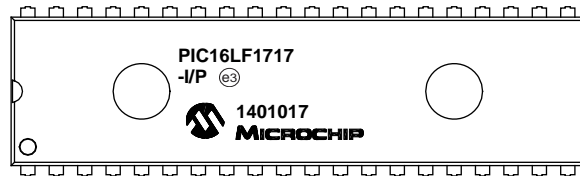
Example



40-Lead PDIP (600 mil)



Example



<b>Legend:</b>	XX...X	Customer-specific information
	Y	Year code (last digit of calendar year)
	YY	Year code (last 2 digits of calendar year)
	WW	Week code (week of January 1 is week '01')
	NNN	Alphanumeric traceability code
	(e3)	Pb-free JEDEC® designator for Matte Tin (Sn)
	*	This package is Pb-free. The Pb-free JEDEC designator (e3) can be found on the outer packaging for this package.

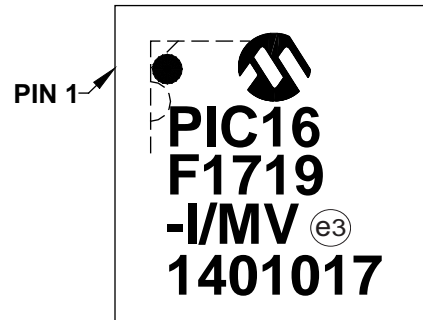
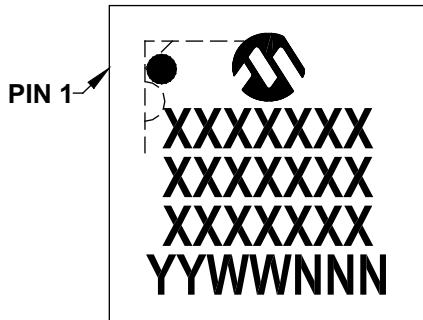
**Note:** In the event the full Microchip part number cannot be marked on one line, it will be carried over to the next line, thus limiting the number of available characters for customer-specific information.

# PIC16(L)F1717/8/9

## Package Marking Information (Continued)

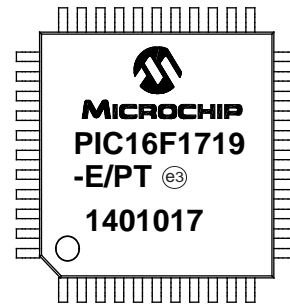
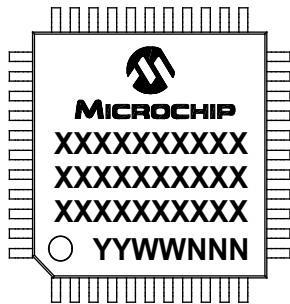
40-Lead UQFN (5x5x0.5 mm)

Example



44-Lead TQFP (10x10x1 mm)

Example



<b>Legend:</b>	XX...X	Customer-specific information
	Y	Year code (last digit of calendar year)
	YY	Year code (last 2 digits of calendar year)
	WW	Week code (week of January 1 is week '01')
	NNN	Alphanumeric traceability code
	(e3)	Pb-free JEDEC® designator for Matte Tin (Sn)
	*	This package is Pb-free. The Pb-free JEDEC designator ((e3)) can be found on the outer packaging for this package.

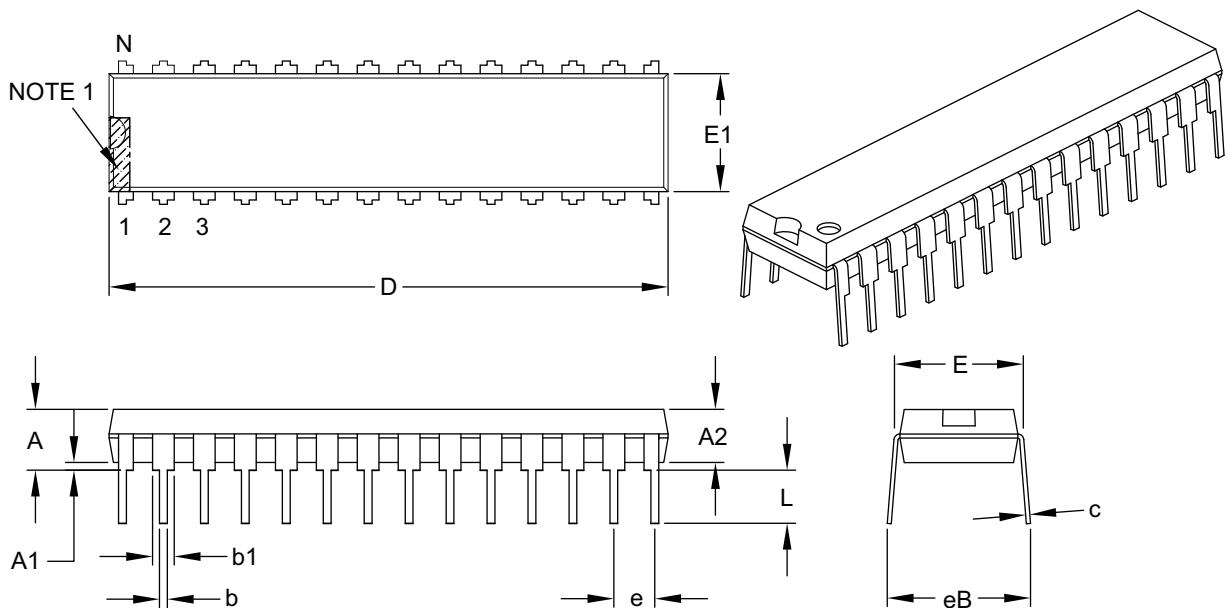
**Note:** In the event the full Microchip part number cannot be marked on one line, it will be carried over to the next line, thus limiting the number of available characters for customer-specific information.

## 37.2 Package Details

The following sections give the technical details of the packages.

### 28-Lead Skinny Plastic Dual In-Line (SP) – 300 mil Body [SPDIP]

**Note:** For the most current package drawings, please see the Microchip Packaging Specification located at <http://www.microchip.com/packaging>



Dimension Limits	Units	INCHES		
		MIN	NOM	MAX
Number of Pins	N	28		
Pitch	e	.100 BSC		
Top to Seating Plane	A	–	–	.200
Molded Package Thickness	A2	.120	.135	.150
Base to Seating Plane	A1	.015	–	–
Shoulder to Shoulder Width	E	.290	.310	.335
Molded Package Width	E1	.240	.285	.295
Overall Length	D	1.345	1.365	1.400
Tip to Seating Plane	L	.110	.130	.150
Lead Thickness	c	.008	.010	.015
Upper Lead Width	b1	.040	.050	.070
Lower Lead Width	b	.014	.018	.022
Overall Row Spacing §	eB	–	–	.430

**Notes:**

1. Pin 1 visual index feature may vary, but must be located within the hatched area.
2. § Significant Characteristic.
3. Dimensions D and E1 do not include mold flash or protrusions. Mold flash or protrusions shall not exceed .010" per side.
4. Dimensioning and tolerancing per ASME Y14.5M.

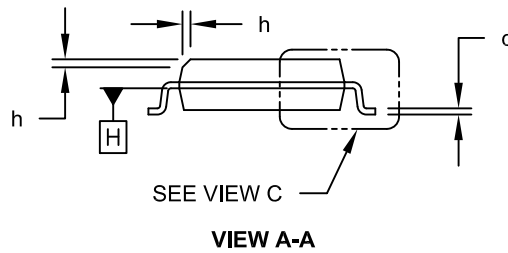
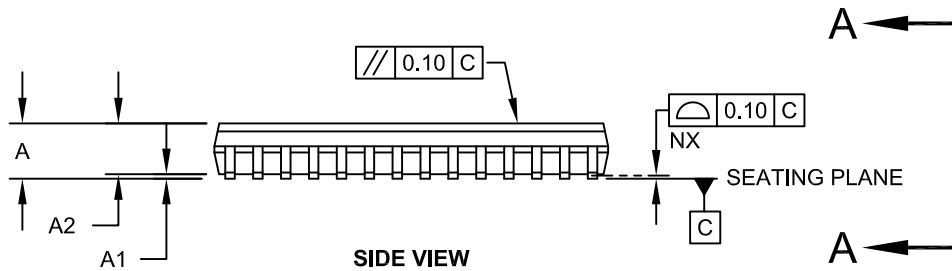
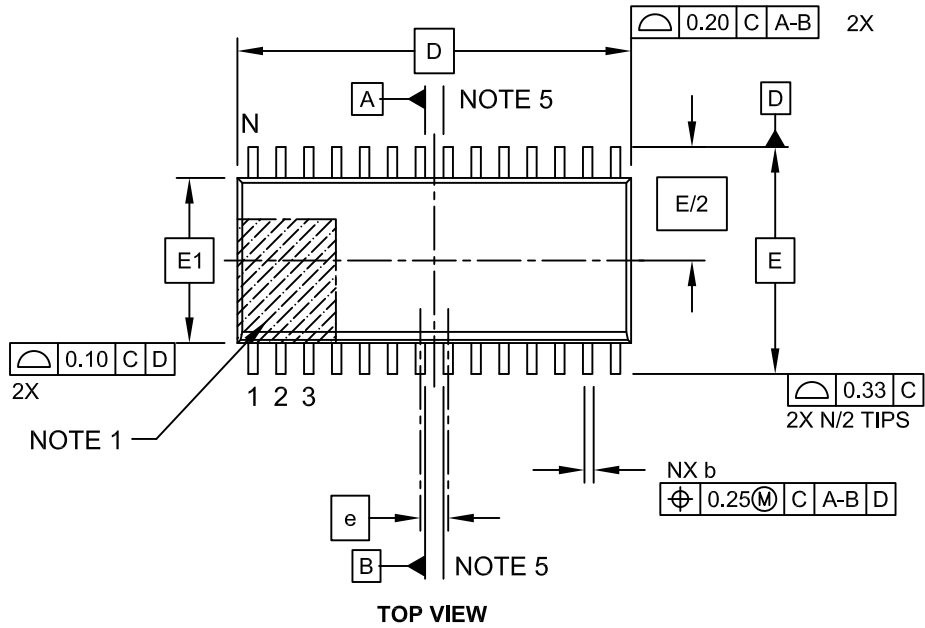
BSC: Basic Dimension. Theoretically exact value shown without tolerances.

Microchip Technology Drawing C04-070B

# PIC16(L)F1717/8/9

## 28-Lead Plastic Small Outline (SO) - Wide, 7.50 mm Body [SOIC]

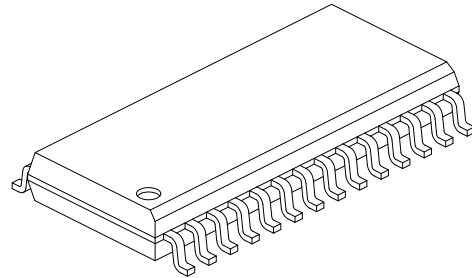
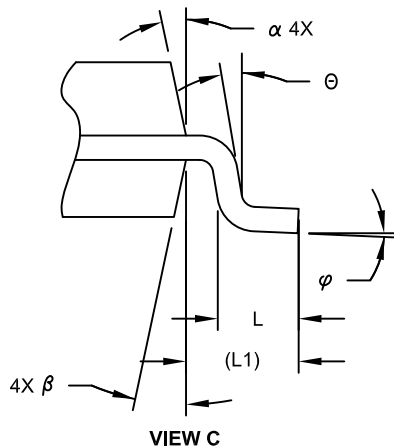
**Note:** For the most current package drawings, please see the Microchip Packaging Specification located at <http://www.microchip.com/packaging>



# PIC16(L)F1717/8/9

## 28-Lead Plastic Small Outline (SO) - Wide, 7.50 mm Body [SOIC]

**Note:** For the most current package drawings, please see the Microchip Packaging Specification located at <http://www.microchip.com/packaging>



Dimension	Units	MILLIMETERS		
		MIN	NOM	MAX
Number of Pins	N	28		
Pitch	e	1.27 BSC		
Overall Height	A	-	-	2.65
Molded Package Thickness	A2	2.05	-	-
Standoff §	A1	0.10	-	0.30
Overall Width	E	10.30 BSC		
Molded Package Width	E1	7.50 BSC		
Overall Length	D	17.90 BSC		
Chamfer (Optional)	h	0.25	-	0.75
Foot Length	L	0.40	-	1.27
Footprint	L1	1.40 REF		
Lead Angle	$\theta$	0°	-	-
Foot Angle	$\varphi$	0°	-	8°
Lead Thickness	c	0.18	-	0.33
Lead Width	b	0.31	-	0.51
Mold Draft Angle Top	$\alpha$	5°	-	15°
Mold Draft Angle Bottom	$\beta$	5°	-	15°

### Notes:

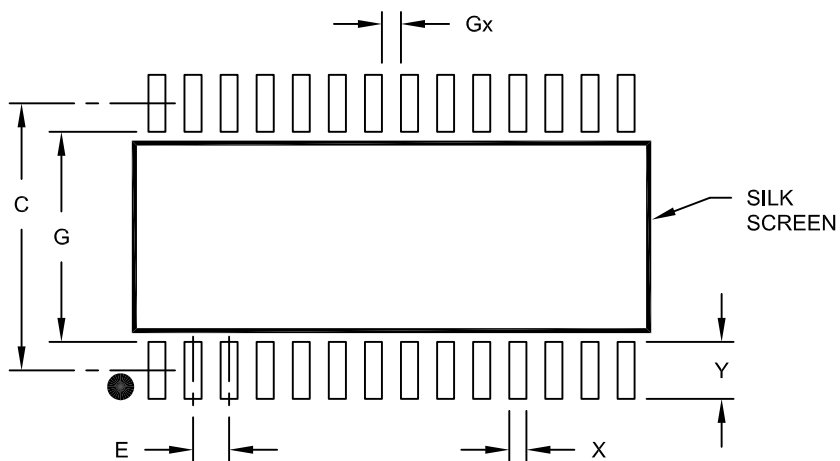
- Pin 1 visual index feature may vary, but must be located within the hatched area.
- § Significant Characteristic
- Dimension D does not include mold flash, protrusions or gate burrs, which shall not exceed 0.15 mm per end. Dimension E1 does not include interlead flash or protrusion, which shall not exceed 0.25 mm per side.
- Dimensioning and tolerancing per ASME Y14.5M
  - BSC: Basic Dimension. Theoretically exact value shown without tolerances.
  - REF: Reference Dimension, usually without tolerance, for information purposes only.
- Datums A & B to be determined at Datum H.

Microchip Technology Drawing C04-052C Sheet 2 of 2

# PIC16(L)F1717/8/9

28-Lead Plastic Small Outline (SO) - Wide, 7.50 mm Body [SOIC]

**Note:** For the most current package drawings, please see the Microchip Packaging Specification located at <http://www.microchip.com/packaging>



## RECOMMENDED LAND PATTERN

Dimension Limits	Units	MILLIMETERS		
		MIN	NOM	MAX
Contact Pitch	E	1.27 BSC		
Contact Pad Spacing	C		9.40	
Contact Pad Width (X28)	X			0.60
Contact Pad Length (X28)	Y			2.00
Distance Between Pads	Gx	0.67		
Distance Between Pads	G	7.40		

**Notes:**

1. Dimensioning and tolerancing per ASME Y14.5M

BSC: Basic Dimension. Theoretically exact value shown without tolerances.

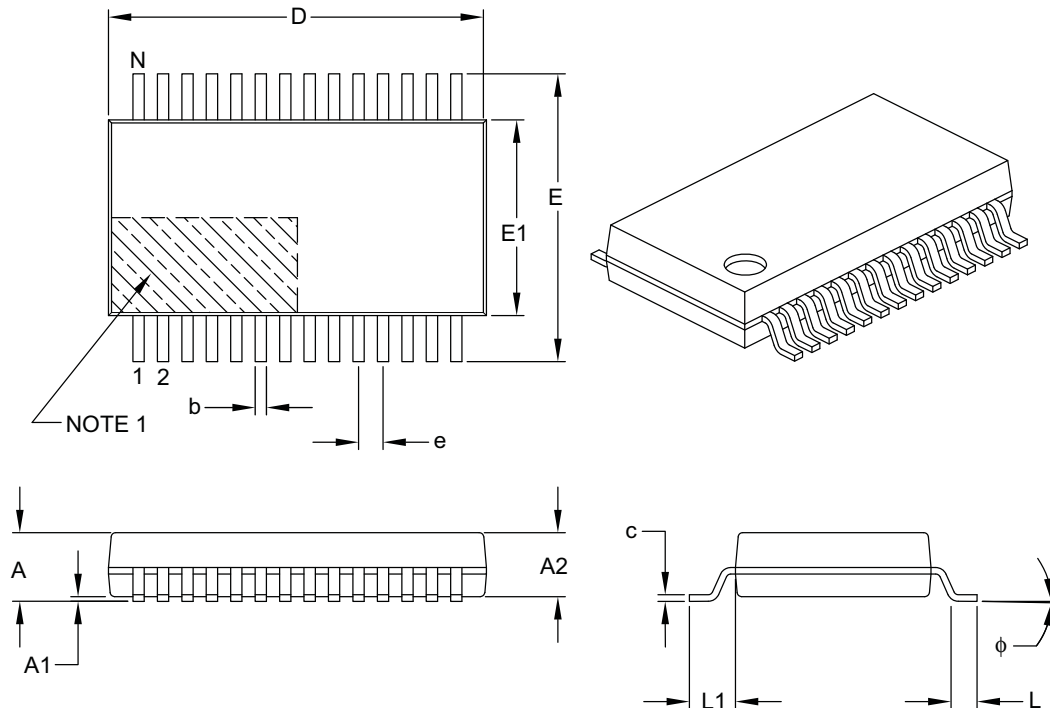
Microchip Technology Drawing No. C04-2052A



# PIC16(L)F1717/8/9

## 28-Lead Plastic Shrink Small Outline (SS) – 5.30 mm Body [SSOP]

**Note:** For the most current package drawings, please see the Microchip Packaging Specification located at <http://www.microchip.com/packaging>



Units		MILLIMETERS		
Dimension Limits		MIN	NOM	MAX
Number of Pins	N	28		
Pitch	e	0.65 BSC		
Overall Height	A	–	–	2.00
Molded Package Thickness	A2	1.65	1.75	1.85
Standoff	A1	0.05	–	–
Overall Width	E	7.40	7.80	8.20
Molded Package Width	E1	5.00	5.30	5.60
Overall Length	D	9.90	10.20	10.50
Foot Length	L	0.55	0.75	0.95
Footprint	L1	1.25 REF		
Lead Thickness	c	0.09	–	0.25
Foot Angle	φ	0°	4°	8°
Lead Width	b	0.22	–	0.38

**Notes:**

- Pin 1 visual index feature may vary, but must be located within the hatched area.
- Dimensions D and E1 do not include mold flash or protrusions. Mold flash or protrusions shall not exceed 0.20 mm per side.
- Dimensioning and tolerancing per ASME Y14.5M.

BSC: Basic Dimension. Theoretically exact value shown without tolerances.

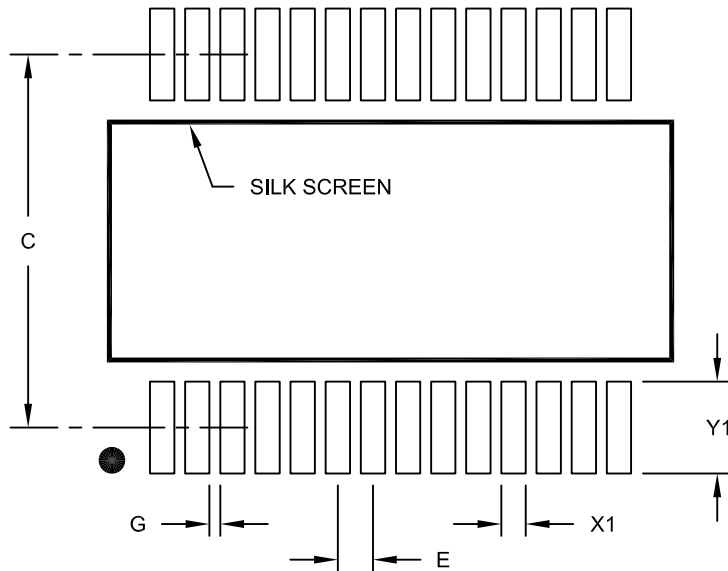
REF: Reference Dimension, usually without tolerance, for information purposes only.

Microchip Technology Drawing C04-073B

# PIC16(L)F1717/8/9

28-Lead Plastic Shrink Small Outline (SS) - 5.30 mm Body [SSOP]

**Note:** For the most current package drawings, please see the Microchip Packaging Specification located at <http://www.microchip.com/packaging>



RECOMMENDED LAND PATTERN

Dimension Limits	Units	MILLIMETERS		
		MIN	NOM	MAX
Contact Pitch	E	0.65 BSC		
Contact Pad Spacing	C		7.20	
Contact Pad Width (X28)	X1			0.45
Contact Pad Length (X28)	Y1			1.75
Distance Between Pads	G	0.20		

Notes:

1. Dimensioning and tolerancing per ASME Y14.5M

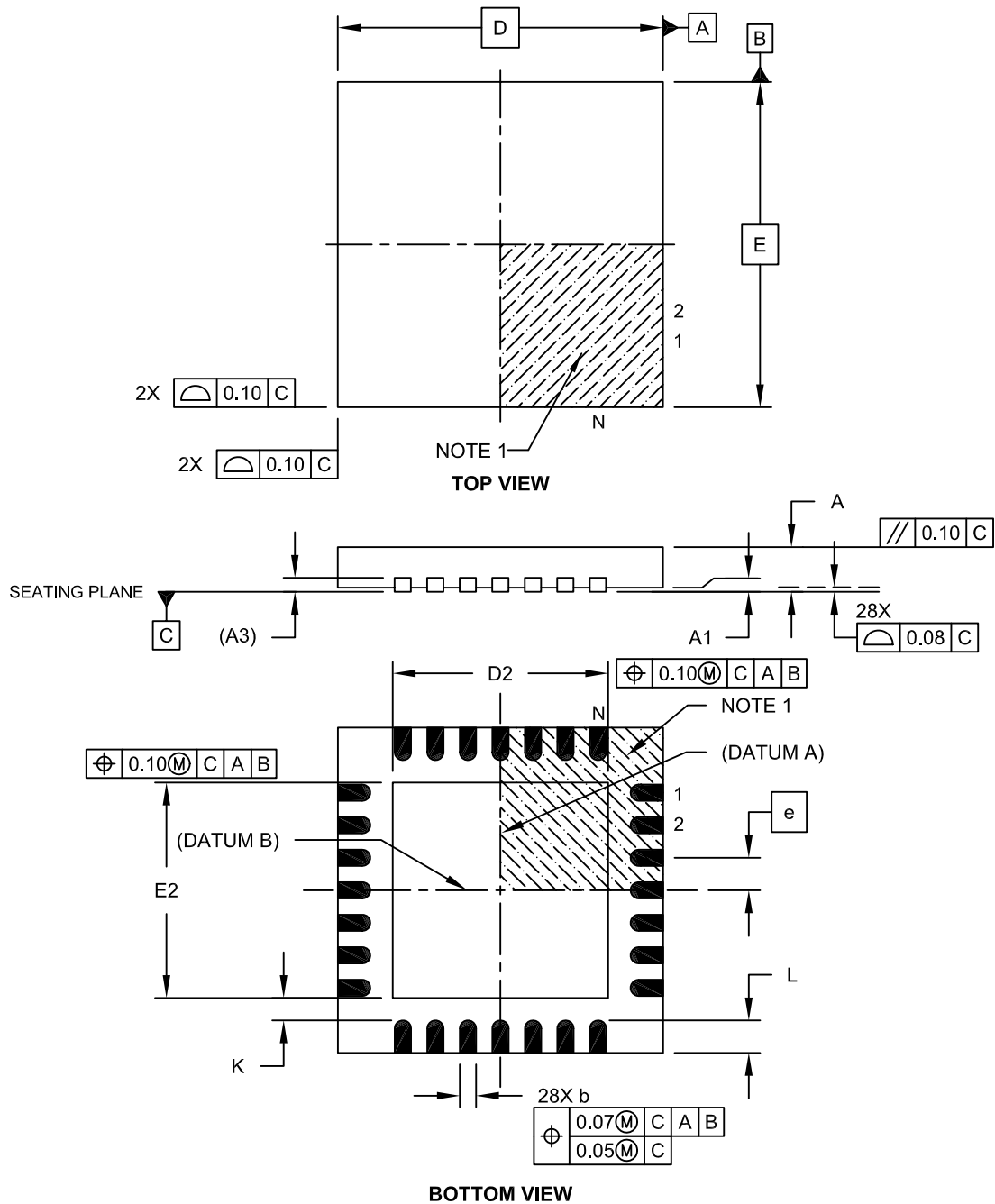
BSC: Basic Dimension. Theoretically exact value shown without tolerances.

Microchip Technology Drawing No. C04-2073A

# PIC16(L)F1717/8/9

## 28-Lead Plastic Ultra Thin Quad Flat, No Lead Package (MV) – 4x4x0.5 mm Body [UQFN]

**Note:** For the most current package drawings, please see the Microchip Packaging Specification located at <http://www.microchip.com/packaging>

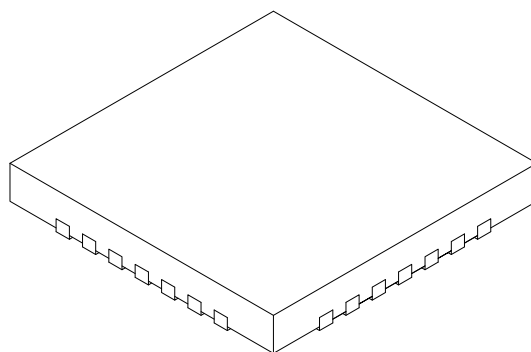


Microchip Technology Drawing C04-152A Sheet 1 of 2

# PIC16(L)F1717/8/9

## 28-Lead Plastic Ultra Thin Quad Flat, No Lead Package (MV) – 4x4x0.5 mm Body [UQFN]

**Note:** For the most current package drawings, please see the Microchip Packaging Specification located at <http://www.microchip.com/packaging>



Dimension Limits	Units	MILLIMETERS		
		MIN	NOM	MAX
Number of Pins	N	28		
Pitch	e	0.40 BSC		
Overall Height	A	0.45	0.50	0.55
Standoff	A1	0.00	0.02	0.05
Contact Thickness	A3	0.127 REF		
Overall Width	E	4.00 BSC		
Exposed Pad Width	E2	2.55	2.65	2.75
Overall Length	D	4.00 BSC		
Exposed Pad Length	D2	2.55	2.65	2.75
Contact Width	b	0.15	0.20	0.25
Contact Length	L	0.30	0.40	0.50
Contact-to-Exposed Pad	K	0.20	-	-

**Notes:**

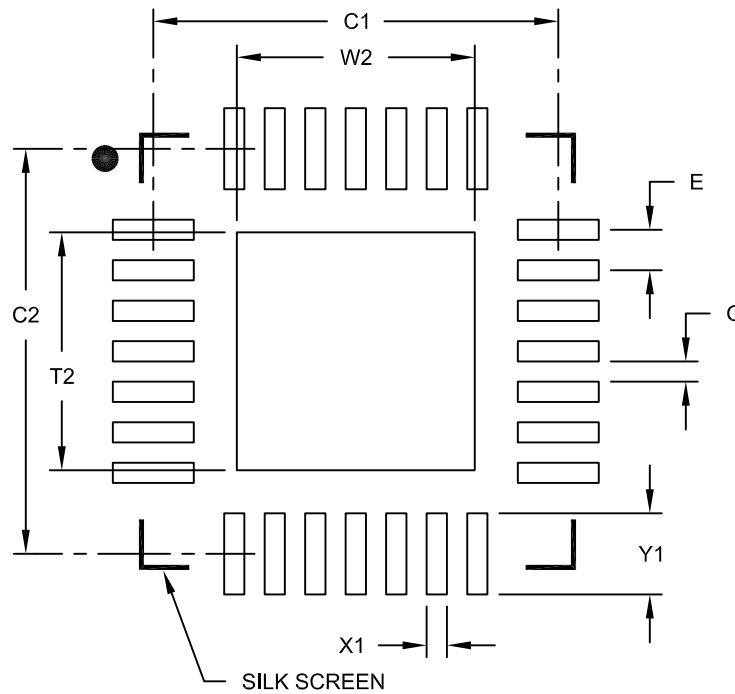
1. Pin 1 visual index feature may vary, but must be located within the hatched area.
2. Package is saw singulated.
3. Dimensioning and tolerancing per ASME Y14.5M.  
BSC: Basic Dimension. Theoretically exact value shown without tolerances.  
REF: Reference Dimension, usually without tolerance, for information purposes only.

Microchip Technology Drawing C04-152A Sheet 2 of 2

# PIC16(L)F1717/8/9

28-Lead Ultra Thin Plastic Quad Flat, No Lead Package (MV) - 4x4 mm Body [UQFN]  
With 0.40 mm Contact Length

**Note:** For the most current package drawings, please see the Microchip Packaging Specification located at <http://www.microchip.com/packaging>



RECOMMENDED LAND PATTERN

Dimension Limits	Units	MILLIMETERS		
		MIN	NOM	MAX
Contact Pitch	E	0,40 BSC		
Optional Center Pad Width	W2			2.35
Optional Center Pad Length	T2			2.35
Contact Pad Spacing	C1		4.00	
Contact Pad Spacing	C2		4.00	
Contact Pad Width (X28)	X1			0.20
Contact Pad Length (X28)	Y1			0.80
Distance Between Pads	G	0.20		

Notes:

1. Dimensioning and tolerancing per ASME Y14.5M

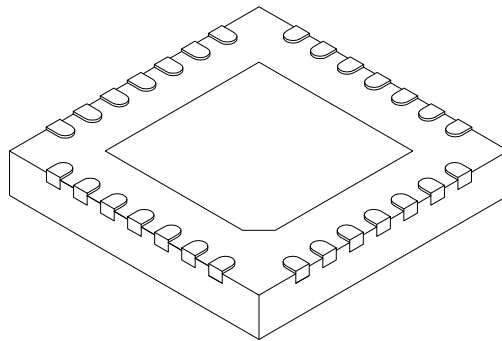
BSC: Basic Dimension. Theoretically exact value shown without tolerances.

Microchip Technology Drawing No. C04-2152A



## 28-Lead Plastic Quad Flat, No Lead Package (MM) - 6x6x0.9mm Body [QFN-S] With 0.40 mm Terminal Length

**Note:** For the most current package drawings, please see the Microchip Packaging Specification located at <http://www.microchip.com/packaging>



Dimension Limits	Units	MILLIMETERS		
		MIN	NOM	MAX
Number of Pins	N	28		
Pitch	e	0.65 BSC		
Overall Height	A	0.80	0.90	1.00
Standoff	A1	0.00	0.02	0.05
Terminal Thickness	A3	0.20 REF		
Overall Width	E	6.00 BSC		
Exposed Pad Width	E2	3.65	3.70	4.70
Overall Length	D	6.00 BSC		
Exposed Pad Length	D2	3.65	3.70	4.70
Terminal Width	b	0.23	0.30	0.35
Terminal Length	L	0.30	0.40	0.50
Terminal-to-Exposed Pad	K	0.20	-	-

**Notes:**

1. Pin 1 visual index feature may vary, but must be located within the hatched area.
2. Package is saw singulated
3. Dimensioning and tolerancing per ASME Y14.5M

BSC: Basic Dimension. Theoretically exact value shown without tolerances.

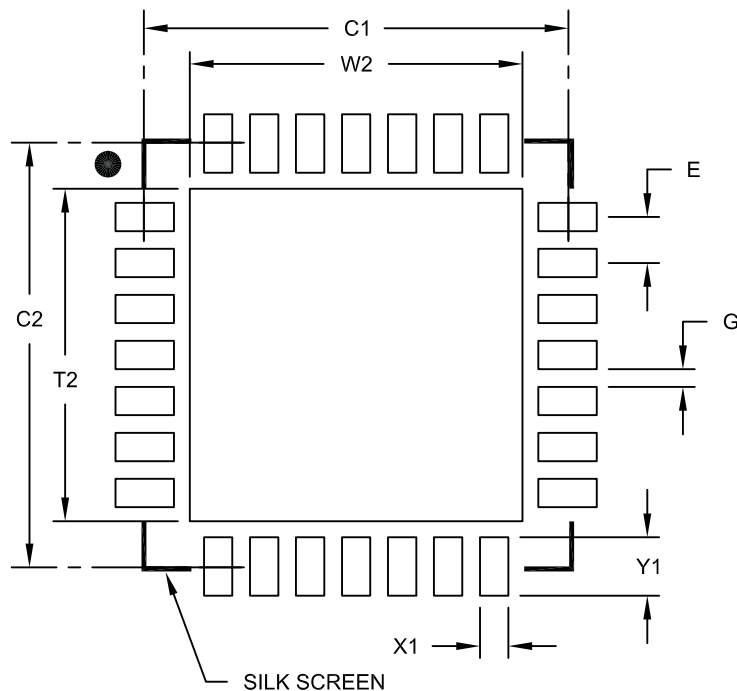
REF: Reference Dimension, usually without tolerance, for information purposes only.

Microchip Technology Drawing C04-124C Sheet 2 of 2

# PIC16(L)F1717/8/9

## 28-Lead Plastic Quad Flat, No Lead Package (MM) – 6x6x0.9 mm Body [QFN-S] with 0.40 mm Contact Length

**Note:** For the most current package drawings, please see the Microchip Packaging Specification located at <http://www.microchip.com/packaging>



RECOMMENDED LAND PATTERN

Dimension Limits	Units	MILLIMETERS		
		MIN	NOM	MAX
Contact Pitch	E	0.65 BSC		
Optional Center Pad Width	W2			4.70
Optional Center Pad Length	T2			4.70
Contact Pad Spacing	C1		6.00	
Contact Pad Spacing	C2		6.00	
Contact Pad Width (X28)	X1			0.40
Contact Pad Length (X28)	Y1			0.85
Distance Between Pads	G	0.25		

Notes:

1. Dimensioning and tolerancing per ASME Y14.5M

BSC: Basic Dimension. Theoretically exact value shown without tolerances.

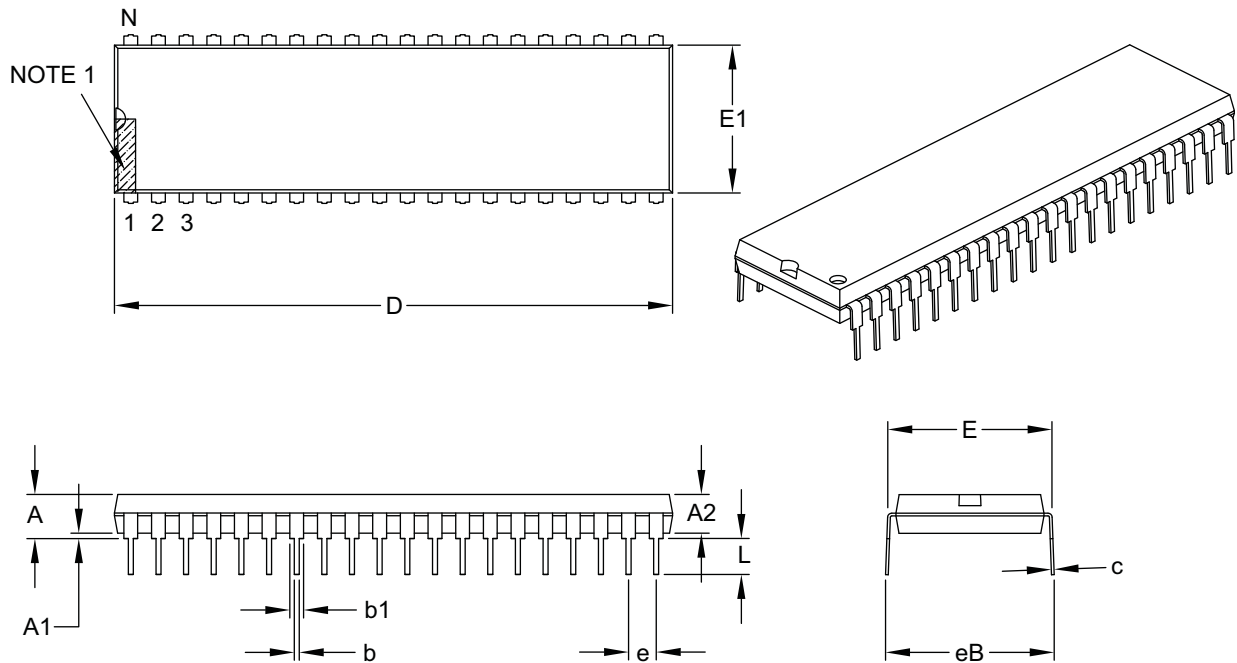
Microchip Technology Drawing No. C04-2124A



# PIC16(L)F1717/8/9

## 40-Lead Plastic Dual In-Line (P) – 600 mil Body [PDIP]

**Note:** For the most current package drawings, please see the Microchip Packaging Specification located at <http://www.microchip.com/packaging>



Dimension Limits	Units	INCHES		
		MIN	NOM	MAX
Number of Pins	N	40		
Pitch	e	.100 BSC		
Top to Seating Plane	A	–	–	.250
Molded Package Thickness	A2	.125	–	.195
Base to Seating Plane	A1	.015	–	–
Shoulder to Shoulder Width	E	.590	–	.625
Molded Package Width	E1	.485	–	.580
Overall Length	D	1.980	–	2.095
Tip to Seating Plane	L	.115	–	.200
Lead Thickness	c	.008	–	.015
Upper Lead Width	b1	.030	–	.070
Lower Lead Width	b	.014	–	.023
Overall Row Spacing §	eB	–	–	.700

**Notes:**

- Pin 1 visual index feature may vary, but must be located within the hatched area.
- § Significant Characteristic.
- Dimensions D and E1 do not include mold flash or protrusions. Mold flash or protrusions shall not exceed .010" per side.
- Dimensioning and tolerancing per ASME Y14.5M.

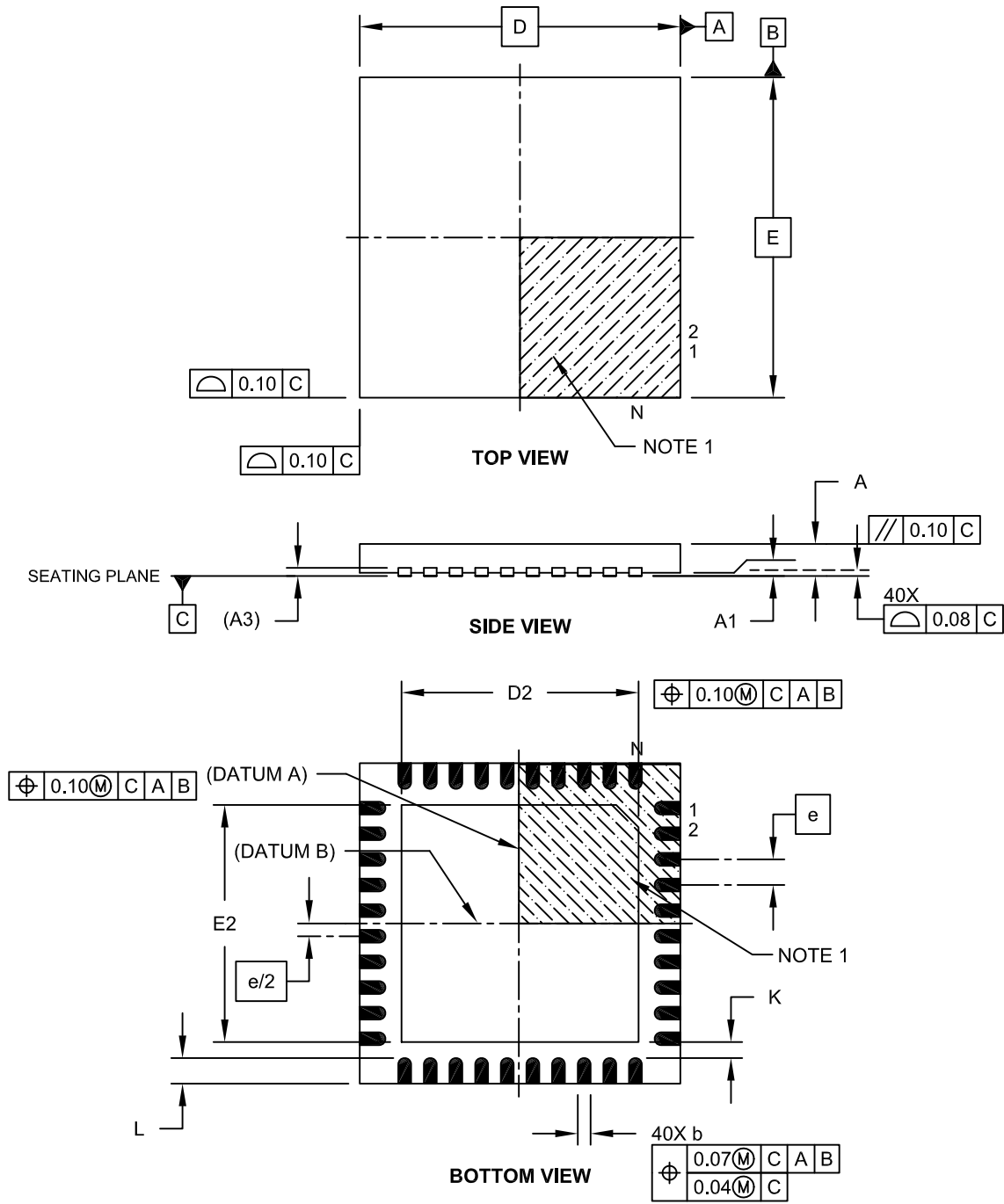
BSC: Basic Dimension. Theoretically exact value shown without tolerances.

Microchip Technology Drawing C04-016B

# PIC16(L)F1717/8/9

## 40-Lead Ultra Thin Plastic Quad Flat, No Lead Package (MV) – 5x5x0.5 mm Body [UQFN]

**Note:** For the most current package drawings, please see the Microchip Packaging Specification located at <http://www.microchip.com/packaging>

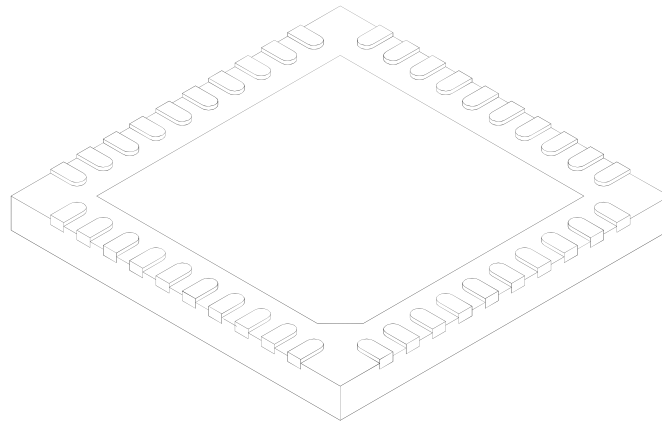


Microchip Technology Drawing C04-156A Sheet 1 of 2

# PIC16(L)F1717/8/9

## 40-Lead Ultra Thin Plastic Quad Flat, No Lead Package (MV) – 5x5x0.5 mm Body [UQFN]

**Note:** For the most current package drawings, please see the Microchip Packaging Specification located at <http://www.microchip.com/packaging>



Units		MILLIMETERS		
Dimension Limits		MIN	NOM	MAX
Number of Pins	N	40		
Pitch	e	0.40 BSC		
Overall Height	A	0.45	0.50	0.55
Standoff	A1	0.00	0.02	0.05
Contact Thickness	A3	0.127 REF		
Overall Width	E	5.00 BSC		
Exposed Pad Width	E2	3.60	3.70	3.80
Overall Length	D	5.00 BSC		
Exposed Pad Length	D2	3.60	3.70	3.80
Contact Width	b	0.15	0.20	0.25
Contact Length	L	0.30	0.40	0.50
Contact-to-Exposed Pad	K	0.20	-	-

**Notes:**

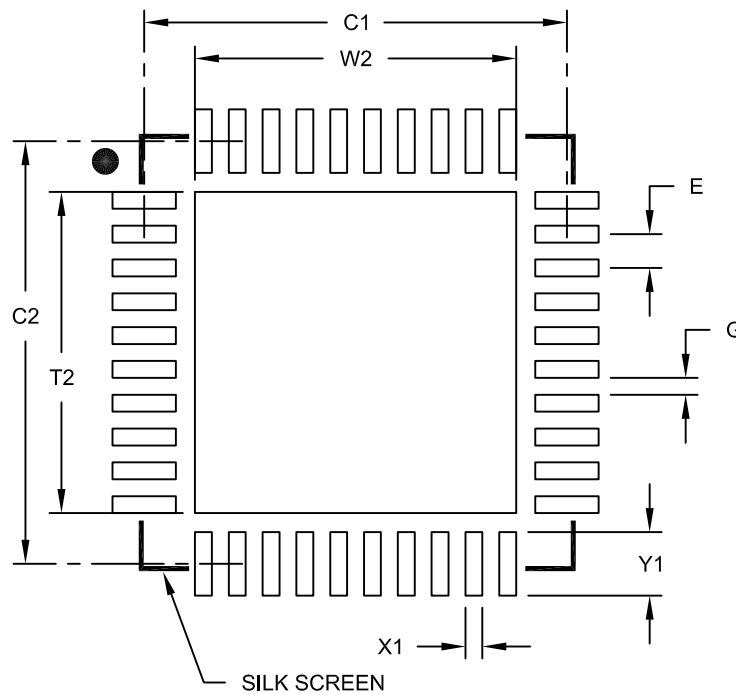
1. Pin 1 visual index feature may vary, but must be located within the hatched area.
2. Package is saw singulated.
3. Dimensioning and tolerancing per ASME Y14.5M.  
BSC: Basic Dimension. Theoretically exact value shown without tolerances.  
REF: Reference Dimension, usually without tolerance, for information purposes only.

Microchip Technology Drawing C04-156A Sheet 2 of 2

# PIC16(L)F1717/8/9

## 40-Lead Plastic Ultra Thin Quad Flat, No Lead Package (MV) - 5x5 mm Body [UQFN]

**Note:** For the most current package drawings, please see the Microchip Packaging Specification located at <http://www.microchip.com/packaging>



RECOMMENDED LAND PATTERN

Dimension Limits	Units	MILLIMETERS		
		MIN	NOM	MAX
Contact Pitch	E	0.40 BSC		
Optional Center Pad Width	W2			3.80
Optional Center Pad Length	T2			3.80
Contact Pad Spacing	C1		5.00	
Contact Pad Spacing	C2		5.00	
Contact Pad Width (X40)	X1			0.20
Contact Pad Length (X40)	Y1			0.75
Distance Between Pads	G	0.20		

**Notes:**

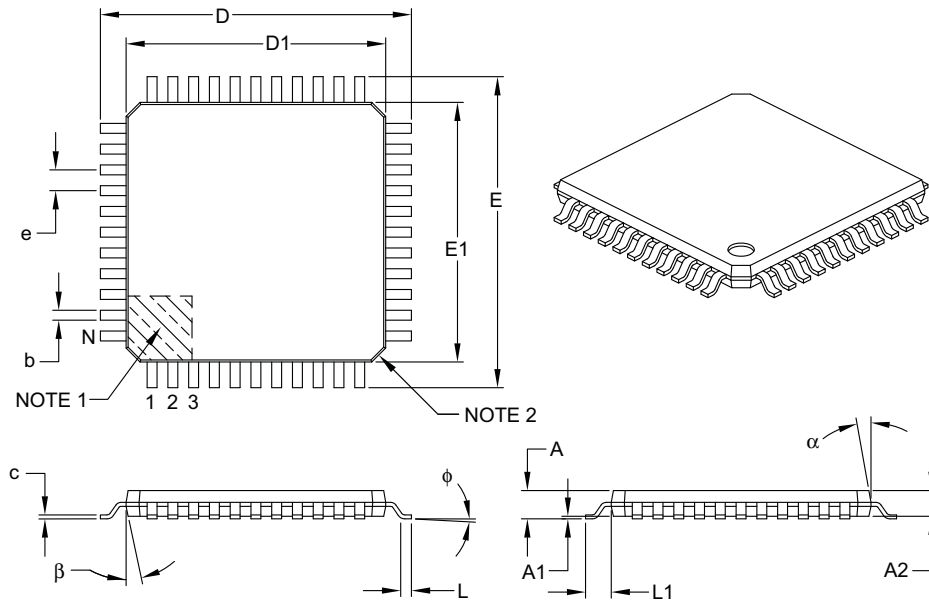
1. Dimensioning and tolerancing per ASME Y14.5M

BSC: Basic Dimension. Theoretically exact value shown without tolerances.

Microchip Technology Drawing No. C04-2156B

## 44-Lead Plastic Thin Quad Flatpack (PT) – 10x10x1 mm Body, 2.00 mm [TQFP]

**Note:** For the most current package drawings, please see the Microchip Packaging Specification located at <http://www.microchip.com/packaging>



Dimension Limits	Units	MILLIMETERS		
		MIN	NOM	MAX
Number of Leads	N	44		
Lead Pitch	e	0.80 BSC		
Overall Height	A	–	–	1.20
Molded Package Thickness	A2	0.95	1.00	1.05
Standoff	A1	0.05	–	0.15
Foot Length	L	0.45	0.60	0.75
Footprint	L1	1.00 REF		
Foot Angle	$\phi$	0°	3.5°	7°
Overall Width	E	12.00 BSC		
Overall Length	D	12.00 BSC		
Molded Package Width	E1	10.00 BSC		
Molded Package Length	D1	10.00 BSC		
Lead Thickness	c	0.09	–	0.20
Lead Width	b	0.30	0.37	0.45
Mold Draft Angle Top	$\alpha$	11°	12°	13°
Mold Draft Angle Bottom	$\beta$	11°	12°	13°

**Notes:**

- Pin 1 visual index feature may vary, but must be located within the hatched area.
- Chamfers at corners are optional; size may vary.
- Dimensions D1 and E1 do not include mold flash or protrusions. Mold flash or protrusions shall not exceed 0.25 mm per side.
- Dimensioning and tolerancing per ASME Y14.5M.

BSC: Basic Dimension. Theoretically exact value shown without tolerances.

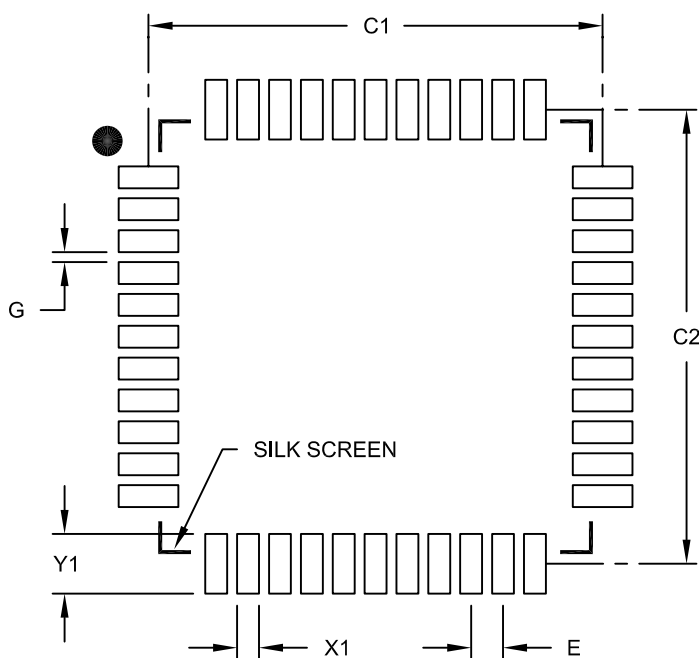
REF: Reference Dimension, usually without tolerance, for information purposes only.

Microchip Technology Drawing C04-076B

# PIC16(L)F1717/8/9

44-Lead Plastic Thin Quad Flatpack (PT) 10X10X1 mm Body, 2.00 mm Footprint [TQFP]

**Note:** For the most current package drawings, please see the Microchip Packaging Specification located at <http://www.microchip.com/packaging>



RECOMMENDED LAND PATTERN

Dimension Limits	Units	MILLIMETERS		
		MIN	NOM	MAX
Contact Pitch	E	0.80 BSC		
Contact Pad Spacing	C1		11.40	
Contact Pad Spacing	C2		11.40	
Contact Pad Width (X44)	X1			0.55
Contact Pad Length (X44)	Y1			1.50
Distance Between Pads	G	0.25		

Notes:

1. Dimensioning and tolerancing per ASME Y14.5M

BSC: Basic Dimension. Theoretically exact value shown without tolerances.

Microchip Technology Drawing No. C04-2076B

## APPENDIX A: DATA SHEET REVISION HISTORY

### Revision A (02/2014)

Initial release of the document.

### Revision B (12/2015)

Chapter 18.0 COG rewritten.

Added High-endurance Flash Data Memory information to cover pages and Memory chapter. Added Section 11.3.1 heading. Added Section 6.3.5: Clock Switching Before Sleep.

Deleted Section 24.4: Low-Power Voltage State.

Updated the Family Types Table and the Product Identification System page.

Updated Examples 3-2 and 21-; Figures 16-2, 18-2, 18-3, 18-4, 18-5, 18-6, 21-1, 22-1, 23-1, 24-1, 27-1, 29-2 and 29-4; Registers 11-8, 11-16, 11-24, 11-32, 11-40, 21-2, 22-1, 23-1, 23-2 and 30-4; Sections 3.3.2, 8.2.2, 11.9.1, 11.9.2, 18.1.1, 18.1.2, 18.1.3, 18-1-4, 18-1.6, 18.2, 18.3.2, 18.3.3, 18.5, 18.5.4, 18.5.5, 18.8.3, 18.10, 20.0, 21.1.3, 22.0, 22.1, 22.1.1, 23.5, 24.0, 24.1, 24.3, 24.4, 24.5, 25.2, 25.8, 30.6, 31.6.2 and 34-1; Tables 3-10, 3-12, 6-1, 12-1, 16-3, 17-3, 21-3, 24-1, 34-1, 34-2, 34-3, 34-4, 34-5, 34-8, 34-11 and 34-24.

Minor typos corrected.

## THE MICROCHIP WEBSITE

Microchip provides online support via our website at [www.microchip.com](http://www.microchip.com). This website is used as a means to make files and information easily available to customers. Accessible by using your favorite Internet browser, the website contains the following information:

- **Product Support** – Data sheets and errata, application notes and sample programs, design resources, user's guides and hardware support documents, latest software releases and archived software
- **General Technical Support** – Frequently Asked Questions (FAQ), technical support requests, online discussion groups, Microchip consultant program member listing
- **Business of Microchip** – Product selector and ordering guides, latest Microchip press releases, listing of seminars and events, listings of Microchip sales offices, distributors and factory representatives

## CUSTOMER CHANGE NOTIFICATION SERVICE

Microchip's customer notification service helps keep customers current on Microchip products. Subscribers will receive e-mail notification whenever there are changes, updates, revisions or errata related to a specified product family or development tool of interest.

To register, access the Microchip website at [www.microchip.com](http://www.microchip.com). Under "Support", click on "Customer Change Notification" and follow the registration instructions.

## CUSTOMER SUPPORT

Users of Microchip products can receive assistance through several channels:

- Distributor or Representative
- Local Sales Office
- Field Application Engineer (FAE)
- Technical Support

Customers should contact their distributor, representative or Field Application Engineer (FAE) for support. Local sales offices are also available to help customers. A listing of sales offices and locations is included in the back of this document.

**Technical support is available through the website at: <http://www.microchip.com/support>**



## PRODUCT IDENTIFICATION SYSTEM

To order or obtain information, e.g., on pricing or delivery, refer to the factory or the listed sales office.

<u>PART NO.</u>	<u>[X]<sup>(1)</sup></u>	-	<u>X</u>	<u>/XX</u>	<u>XXX</u>
Device	Tape and Reel Option		Temperature Range	Package	Pattern
<p><b>Device:</b> PIC16F1717, PIC16LF1717, PIC16F1718, PIC16LF1718, PIC16F1719, PIC16LF1719</p> <p><b>Tape and Reel Option:</b> Blank = Standard packaging (tube or tray) T = Tape and Reel<sup>(1)</sup></p> <p><b>Temperature Range:</b> I = -40°C to +85°C (Industrial) E = -40°C to +125°C (Extended)</p> <p><b>Package:<sup>(2)</sup></b> MV = UQFN, 28-lead 4x4x0.5mm MV = UQFN, 40-lead 5x5x0.5mm MM = QFN-S, 28-lead 6x6x0.9mm P = PDIP, 40-lead PT = TQFP, 44-lead 10x10x1mm SO = SOIC, 28-lead SP = SPDIP, 28-lead SS = SSOP, 28-lead</p> <p><b>Pattern:</b> QTP, SQTP, Code or Special Requirements (blank otherwise)</p>					
<p><b>Examples:</b></p> <p>a) PIC16LF1717- I/P Industrial temperature PDIP package</p> <p>b) PIC16F1718- E/SS Extended temperature, SSOP package</p> <p><b>Note 1:</b> Tape and Reel identifier only appears in the catalog part number description. This identifier is used for ordering purposes and is not printed on the device package. Check with your Microchip Sales Office for package availability with the Tape and Reel option.</p> <p><b>2:</b> Small form-factor packaging options may be available. Please check <a href="http://www.microchip.com/packaging">www.microchip.com/packaging</a> for small-form factor package availability, or contact your local Sales Office.</p>					

---

---

**Note the following details of the code protection feature on Microchip devices:**

- Microchip products meet the specification contained in their particular Microchip Data Sheet.
- Microchip believes that its family of products is one of the most secure families of its kind on the market today, when used in the intended manner and under normal conditions.
- There are dishonest and possibly illegal methods used to breach the code protection feature. All of these methods, to our knowledge, require using the Microchip products in a manner outside the operating specifications contained in Microchip's Data Sheets. Most likely, the person doing so is engaged in theft of intellectual property.
- Microchip is willing to work with the customer who is concerned about the integrity of their code.
- Neither Microchip nor any other semiconductor manufacturer can guarantee the security of their code. Code protection does not mean that we are guaranteeing the product as "unbreakable."

Code protection is constantly evolving. We at Microchip are committed to continuously improving the code protection features of our products. Attempts to break Microchip's code protection feature may be a violation of the Digital Millennium Copyright Act. If such acts allow unauthorized access to your software or other copyrighted work, you may have a right to sue for relief under that Act.

Information contained in this publication regarding device applications and the like is provided only for your convenience and may be superseded by updates. It is your responsibility to ensure that your application meets with your specifications. MICROCHIP MAKES NO REPRESENTATIONS OR WARRANTIES OF ANY KIND WHETHER EXPRESS OR IMPLIED, WRITTEN OR ORAL, STATUTORY OR OTHERWISE, RELATED TO THE INFORMATION, INCLUDING BUT NOT LIMITED TO ITS CONDITION, QUALITY, PERFORMANCE, MERCHANTABILITY OR FITNESS FOR PURPOSE. Microchip disclaims all liability arising from this information and its use. Use of Microchip devices in life support and/or safety applications is entirely at the buyer's risk, and the buyer agrees to defend, indemnify and hold harmless Microchip from any and all damages, claims, suits, or expenses resulting from such use. No licenses are conveyed, implicitly or otherwise, under any Microchip intellectual property rights unless otherwise stated.

#### **Trademarks**

The Microchip name and logo, the Microchip logo, dsPIC, FlashFlex, flexPWR, JukeBlox, KEELOQ, KEELOQ logo, Klear, LANCheck, MediaLB, MOST, MOST logo, MPLAB, OptoLyzer, PIC, PICSTART, PIC<sup>32</sup> logo, RightTouch, SpyNIC, SST, SST Logo, SuperFlash and UNI/O are registered trademarks of Microchip Technology Incorporated in the U.S.A. and other countries.

The Embedded Control Solutions Company and mTouch are registered trademarks of Microchip Technology Incorporated in the U.S.A.

Analog-for-the-Digital Age, BodyCom, chipKIT, chipKIT logo, CodeGuard, dsPICDEM, dsPICDEM.net, ECAN, In-Circuit Serial Programming, ICSP, Inter-Chip Connectivity, KlearNet, KlearNet logo, MiWi, motorBench, MPASM, MPF, MPLAB Certified logo, MPLIB, MPLINK, MultiTRAK, NetDetach, Omniscient Code Generation, PICDEM, PICDEM.net, PICkit, PICtail, RightTouch logo, REAL ICE, SQI, Serial Quad I/O, Total Endurance, TSHARC, USBCheck, VariSense, ViewSpan, WiperLock, Wireless DNA, and ZENA are trademarks of Microchip Technology Incorporated in the U.S.A. and other countries.

SQTP is a service mark of Microchip Technology Incorporated in the U.S.A.

Silicon Storage Technology is a registered trademark of Microchip Technology Inc. in other countries.

GestIC is a registered trademark of Microchip Technology Germany II GmbH & Co. KG, a subsidiary of Microchip Technology Inc., in other countries.

All other trademarks mentioned herein are property of their respective companies.

© 2014-2015, Microchip Technology Incorporated, Printed in the U.S.A., All Rights Reserved.

ISBN: 978-1-5224-0050-9

**QUALITY MANAGEMENT SYSTEM**  
**CERTIFIED BY DNV**  
**== ISO/TS 16949 ==**

*Microchip received ISO/TS-16949:2009 certification for its worldwide headquarters, design and wafer fabrication facilities in Chandler and Tempe, Arizona; Gresham, Oregon and design centers in California and India. The Company's quality system processes and procedures are for its PIC® MCUs and dsPIC® DSCs, KEELOQ® code hopping devices, Serial EEPROMs, microperipherals, nonvolatile memory and analog products. In addition, Microchip's quality system for the design and manufacture of development systems is ISO 9001:2000 certified.*



# MICROCHIP

## Worldwide Sales and Service

### AMERICAS

**Corporate Office**  
2355 West Chandler Blvd.  
Chandler, AZ 85224-6199  
Tel: 480-792-7200  
Fax: 480-792-7277  
Technical Support:  
<http://www.microchip.com/support>  
Web Address:  
[www.microchip.com](http://www.microchip.com)

**Atlanta**  
Duluth, GA  
Tel: 678-957-9614  
Fax: 678-957-1455

**Austin, TX**  
Tel: 512-257-3370

**Boston**  
Westborough, MA  
Tel: 774-760-0087  
Fax: 774-760-0088

**Chicago**  
Itasca, IL  
Tel: 630-285-0071  
Fax: 630-285-0075

**Cleveland**  
Independence, OH  
Tel: 216-447-0464  
Fax: 216-447-0643

**Dallas**  
Addison, TX  
Tel: 972-818-7423  
Fax: 972-818-2924

**Detroit**  
Novi, MI  
Tel: 248-848-4000

**Houston, TX**  
Tel: 281-894-5983

**Indianapolis**  
Noblesville, IN  
Tel: 317-773-8323  
Fax: 317-773-5453

**Los Angeles**  
Mission Viejo, CA  
Tel: 949-462-9523  
Fax: 949-462-9608

**New York, NY**  
Tel: 631-435-6000

**San Jose, CA**  
Tel: 408-735-9110

**Canada - Toronto**  
Tel: 905-673-0699  
Fax: 905-673-6509

### ASIA/PACIFIC

**Asia Pacific Office**  
Suites 3707-14, 37th Floor  
Tower 6, The Gateway  
Harbour City, Kowloon

**Hong Kong**  
Tel: 852-2943-5100  
Fax: 852-2401-3431

**Australia - Sydney**  
Tel: 61-2-9868-6733  
Fax: 61-2-9868-6755

**China - Beijing**  
Tel: 86-10-8569-7000  
Fax: 86-10-8528-2104

**China - Chengdu**  
Tel: 86-28-8665-5511  
Fax: 86-28-8665-7889

**China - Chongqing**  
Tel: 86-23-8980-9588  
Fax: 86-23-8980-9500

**China - Dongguan**  
Tel: 86-769-8702-9880

**China - Hangzhou**  
Tel: 86-571-8792-8115  
Fax: 86-571-8792-8116

**China - Hong Kong SAR**  
Tel: 852-2943-5100  
Fax: 852-2401-3431

**China - Nanjing**  
Tel: 86-25-8473-2460  
Fax: 86-25-8473-2470

**China - Qingdao**  
Tel: 86-532-8502-7355  
Fax: 86-532-8502-7205

**China - Shanghai**  
Tel: 86-21-5407-5533  
Fax: 86-21-5407-5066

**China - Shenyang**  
Tel: 86-24-2334-2829  
Fax: 86-24-2334-2393

**China - Shenzhen**  
Tel: 86-755-8864-2200  
Fax: 86-755-8203-1760

**China - Wuhan**  
Tel: 86-27-5980-5300  
Fax: 86-27-5980-5118

**China - Xian**  
Tel: 86-29-8833-7252  
Fax: 86-29-8833-7256

### ASIA/PACIFIC

**China - Xiamen**  
Tel: 86-592-2388138  
Fax: 86-592-2388130

**China - Zhuhai**  
Tel: 86-756-3210040  
Fax: 86-756-3210049

**India - Bangalore**  
Tel: 91-80-3090-4444  
Fax: 91-80-3090-4123

**India - New Delhi**  
Tel: 91-11-4160-8631  
Fax: 91-11-4160-8632

**India - Pune**  
Tel: 91-20-3019-1500

**Japan - Osaka**  
Tel: 81-6-6152-7160  
Fax: 81-6-6152-9310

**Japan - Tokyo**  
Tel: 81-3-6880-3770  
Fax: 81-3-6880-3771

**Korea - Daegu**  
Tel: 82-53-744-4301  
Fax: 82-53-744-4302

**Korea - Seoul**  
Tel: 82-2-554-7200  
Fax: 82-2-558-5932 or  
82-2-558-5934

**Malaysia - Kuala Lumpur**  
Tel: 60-3-6201-9857  
Fax: 60-3-6201-9859

**Malaysia - Penang**  
Tel: 60-4-227-8870  
Fax: 60-4-227-4068

**Philippines - Manila**  
Tel: 63-2-634-9065  
Fax: 63-2-634-9069

**Singapore**  
Tel: 65-6334-8870  
Fax: 65-6334-8850

**Taiwan - Hsin Chu**  
Tel: 886-3-5778-366  
Fax: 886-3-5770-955

**Taiwan - Kaohsiung**  
Tel: 886-7-213-7828

**Taiwan - Taipei**  
Tel: 886-2-2508-8600  
Fax: 886-2-2508-0102

**Thailand - Bangkok**  
Tel: 66-2-694-1351  
Fax: 66-2-694-1350

### EUROPE

**Austria - Wels**  
Tel: 43-7242-2244-39  
Fax: 43-7242-2244-393

**Denmark - Copenhagen**  
Tel: 45-4450-2828  
Fax: 45-4485-2829

**France - Paris**  
Tel: 33-1-69-53-63-20  
Fax: 33-1-69-30-90-79

**Germany - Dusseldorf**  
Tel: 49-2129-3766400

**Germany - Karlsruhe**  
Tel: 49-721-625370

**Germany - Munich**  
Tel: 49-89-627-144-0  
Fax: 49-89-627-144-44

**Italy - Milan**  
Tel: 39-0331-742611  
Fax: 39-0331-466781

**Italy - Venice**  
Tel: 39-049-7625286

**Netherlands - Drunen**  
Tel: 31-416-690399  
Fax: 31-416-690340

**Poland - Warsaw**  
Tel: 48-22-3325737

**Spain - Madrid**  
Tel: 34-91-708-08-90  
Fax: 34-91-708-08-91

**Sweden - Stockholm**  
Tel: 46-8-5090-4654

**UK - Wokingham**  
Tel: 44-118-921-5800  
Fax: 44-118-921-5820

07/14/15

# Mouser Electronics

Authorized Distributor

Click to View Pricing, Inventory, Delivery & Lifecycle Information:

## Microchip:

[PIC16C54AT-10I/SS](#) [PIC16C54AT-20/SS](#) [PIC16C54A-20E/P](#) [PIC16C54-10E/P](#) [PIC16C54AT-10E/SO](#)  
[PIC16C54AT-10E/SS](#) [PIC16C54AT-04E/SO](#) [PIC16C54AT-04E/SS](#) [PIC16C54AT-04/SS](#) [PIC16C54A-10E/P](#)  
[PIC16C54A-10E/SS](#) [PIC16C54AT-10/SS](#) [PIC16C54-10E/SO](#) [PIC16C54-10E/SS](#) [PIC16C54AT-20E/SO](#)  
[PIC16C54AT-20E/SS](#) [PIC16C54A-04E/SS](#) [PIC16C54A-20E/SO](#) [PIC16F1719-I/P](#) [PIC16LF1718-I/MV](#) [PIC16F1718-](#)  
[I/SS](#) [PIC16F1718-I/MV](#) [PIC16LF1717-I/PT](#) [PIC16LF1718-I/SP](#) [PIC16F1718T-I/SS](#) [PIC16LF1719-E/P](#) [PIC16F1717-](#)  
[I/PT](#) [PIC16F1718-I/ML](#) [PIC16LF1717-E/PT](#) [PIC16F1718T-I/MV](#) [PIC16LF1717T-I/PT](#) [PIC16F1719-E/MV](#)  
[PIC16F1719-I/MV](#) [PIC16LF1718-I/ML](#) [PIC16F1717T-I/MV](#) [PIC16LF1718-E/SS](#) [PIC16F1719-I/PT](#) [PIC16LF1719-E/MV](#)  
[PIC16F1717-I/P](#) [PIC16LF1717T-I/MV](#) [PIC16LF1719-I/P](#) [PIC16LF1718-I/SS](#) [PIC16LF1719-I/PT](#) [PIC16LF1718-E/SO](#)  
[PIC16LF1717-E/MV](#) [PIC16LF1717-E/P](#) [PIC16F1718-I/SP](#) [PIC16LF1718-I/SO](#) [PIC16LF1719T-I/MV](#) [PIC16F1717-](#)  
[E/MV](#) [PIC16F1719T-I/MV](#) [PIC16LF1717-I/MV](#) [PIC16LF1719T-I/PT](#) [PIC16F1718-E/MV](#) [PIC16LF1718-E/SP](#)  
[PIC16LF1718-E/ML](#) [PIC16LF1718T-I/SS](#) [PIC16F1717-I/MV](#) [PIC16LF1719-E/PT](#) [PIC16F1719T-I/PT](#) [PIC16LF1717-](#)  
[I/P](#) [PIC16F1717T-I/PT](#) [PIC16LF1718T-I/ML](#) [PIC16F1718T-I/SO](#) [PIC16LF1719-I/MV](#) [PIC16F1718T-I/ML](#)  
[PIC16LF1718-E/MV](#) [PIC16LF1718T-I/MV](#) [PIC16F1718-I/SO](#) [PIC16LF1718T-I/SO](#) [PIC16F1719-E/P](#) [PIC16F1718-](#)  
[E/SO](#) [PIC16F1718-E/SP](#) [PIC16F1718-E/SS](#) [PIC16F1717-E/PT](#) [PIC16F1718-E/ML](#) [PIC16F1717-E/P](#) [PIC16F1719-](#)  
[E/PT](#)



Компания «ЭлектроПласт» предлагает заключение долгосрочных отношений при поставках импортных электронных компонентов на взаимовыгодных условиях!

Наши преимущества:

- Оперативные поставки широкого спектра электронных компонентов отечественного и импортного производства напрямую от производителей и с крупнейших мировых складов;
- Поставка более 17-ти миллионов наименований электронных компонентов;
- Поставка сложных, дефицитных, либо снятых с производства позиций;
- Оперативные сроки поставки под заказ (от 5 рабочих дней);
- Экспресс доставка в любую точку России;
- Техническая поддержка проекта, помощь в подборе аналогов, поставка прототипов;
- Система менеджмента качества сертифицирована по Международному стандарту ISO 9001;
- Лицензия ФСБ на осуществление работ с использованием сведений, составляющих государственную тайну;
- Поставка специализированных компонентов (Xilinx, Altera, Analog Devices, Intersil, Interpoint, Microsemi, Aeroflex, Peregrine, Syfer, Eurofarad, Texas Instrument, Miteq, Cobham, E2V, MA-COM, Hittite, Mini-Circuits, General Dynamics и др.);

Помимо этого, одним из направлений компании «ЭлектроПласт» является направление «Источники питания». Мы предлагаем Вам помощь Конструкторского отдела:

- Подбор оптимального решения, техническое обоснование при выборе компонента;
- Подбор аналогов;
- Консультации по применению компонента;
- Поставка образцов и прототипов;
- Техническая поддержка проекта;
- Защита от снятия компонента с производства.



#### Как с нами связаться

**Телефон:** 8 (812) 309 58 32 (многоканальный)

**Факс:** 8 (812) 320-02-42

**Электронная почта:** [org@eplast1.ru](mailto:org@eplast1.ru)

**Адрес:** 198099, г. Санкт-Петербург, ул. Калинина, дом 2, корпус 4, литера А.