

TPC-2000 Series

Modular Industrial Thin-Client Panel Computer with 21.5" Full HD/18.5" HD/17" SXGA/15" XGA/12" XGA LED LCD and Intel® Celeron® J3455 Processor

NEW



Features

- Intel® Celeron® J3455 quad-core, 1.50 GHz, processor with 4GB DDR3L SODIMM
- Modular design enables flexible configuration and easy maintenance and upgrades
- Front panel module with P-CAP multi-touch sensor available in various sizes (the 12.1" module is equipped with 5-wire resistive touch control)
- Industrial-grade LED LCD with a lifetime of 50,000 hours
- Built-in intelligent home key and i-key (only for models with P-CAP touch control)
- System status LED indicators in front panel
- Supports 1 x full-size mini PCIe, 1 x iDoor module, and 1 x HDD bay
- IP66-rated front panel and panel mount
- Built-in Wi-Fi antenna and NFC reader on front panel (with optional Wi-Fi/NFC module)
- Integrated power isolation to minimize field interference
- Supports Advantech's WISE-PaaS/RMM remote device management software
- Up to 3 levels of logo customization (optional)

Introduction

The TPC-2000 series is the first modular range of Advantech's industrial thin-client offerings. Featuring a low-power Intel® Celeron® J3455 processor with 4GB of DDR3L SODIMM and an industrial-grade LCD with 6H surface hardness and P-CAP or 5-wire resistive touch control, TPC-2000 series systems offer a sufficient display area and excellent computing performance in a compact, fanless form factor. The modular design ensures flexible configuration according to usage requirements and easy maintenance/upgrades. The system's robust enclosure is equipped with a die-cast aluminum alloy front bezel and IP66 rating for protection from dust and water ingress, making the TPC-2000 series suitable for harsh environments. TPC-2000 systems also feature a mini-PCIe slot that can be used to integrate Advantech's iDoor technology to support additional I/O, isolated digital I/O, fieldbus protocols, 3G/GPS/GPRS communication, and MRAM in order to satisfy the requirements of various industrial automation applications. Moreover, optional Wi-Fi/NFC antennas can be built into the front panel for enhanced connectivity and signal reception.

System Specifications

General

- BIOS** AMI UEFI
- Certification** BSMI, CCC, CE, FCC Class A, UL, EAC
- Cooling System** Fanless design
- Enclosure** Die-cast aluminum alloy front bezel with SECC rear cover
- Mount Options** Panel mount kit with optional stand mount and VESA mount kits
- OS Support** Microsoft® Windows 10 IoT Core, Windows 10 IoT Enterprise LTSB Entry
- Power Input** 24 V_{DC} ± 20%
- Watchdog Timer** 1 ~ 255 sec (system)

System Hardware

- CPU** Intel® Celeron® J3455, 1.50 GHz
- Memory** 4 GB of DDR3L 1600 MHz SODIMM SDRAM (up to 8 GB)
- LAN** 2 x Intel® I210 10/100/1000 Base-T
- Expansion Slots** 1 x full-size mini PCIe with support for a GSM 11.11 SIM card
- Storage** 1 x M.2 (2242)
1 x 2.5" SATA SSD
- I/O** 2 x RS-232/422/485
2 x USB 3.0
2 x USB 2.0
1 x Audio line out
1 x DisplayPort

Environment

- Humidity** 10 ~ 95% RH @ 40 °C, non-condensing
- Ingress Protection** IP66 rating for the front panel
- Vibration Protection** With SSD: 1 Grms (5 ~ 500 Hz) (operating, random vibration)

System/Front Panel Selection

Category	Item	12.1"	15"	17"	18.5"	21.5"
LCD	Display Type	XGA TFT LED LCD	XGA TFT LED LCD	SXGA TFT LED LCD	HD TFT LED LCD	Full HD TFT LED LCD
	Max. Resolution	1024 x 768	1024 x 768	1280 x 1024	1366 x 768	1920 x 1080
	Max. Color	16.2 M	16.7 M	16.7 M	16.7 M	16.7 M
	Luminance (cd/m ²)	600	400	350	250	300
	Viewing Angle (H/V°)	160/140	160/140	160/140	170/160	178/178
	Backlight Life	50,000 hrs	50,000 hrs	50,000 hrs	30,000 hrs	50,000 hrs
	Contrast Ratio	700:1	700:1	800:1	1000:1	5000:1
Touch Panel	Type	5-wire resistive	Projected capacitive	Projected capacitive	Projected capacitive	Projected capacitive
	Light Transmission	Above 75%	90% ± 3%	90% ± 3%	90% ± 3%	90% ± 3%
	Anti-glare Treatment	Anti-glare	90% ± 3%	90% ± 3%	90% ± 3%	90% ± 3%
System	Temperature	Operating	0 ~ 50 °C (32 ~ 122 °F)	0 ~ 50 °C (32 ~ 122 °F)	0 ~ 50 °C (32 ~ 122 °F)	0 ~ 50 °C (32 ~ 122 °F)
		Storage	-30 ~ 70 °C (-22 ~ 158 °F)	-30 ~ 70 °C (-22 ~ 158 °F)	-30 ~ 70 °C (-22 ~ 158 °F)	-20 ~ 60 °C (-4 ~ 140 °F)
	Power Consumption	46.5 W	44 W	51 W	48 W	55 W
	Wi-Fi/NFC in Front Panel	N/A		Antenna integrated into the front panel with the inclusion of an optional module		
	Built-In iKey	No	Yes	Yes	Yes	Yes

Dimensions

Unit: mm

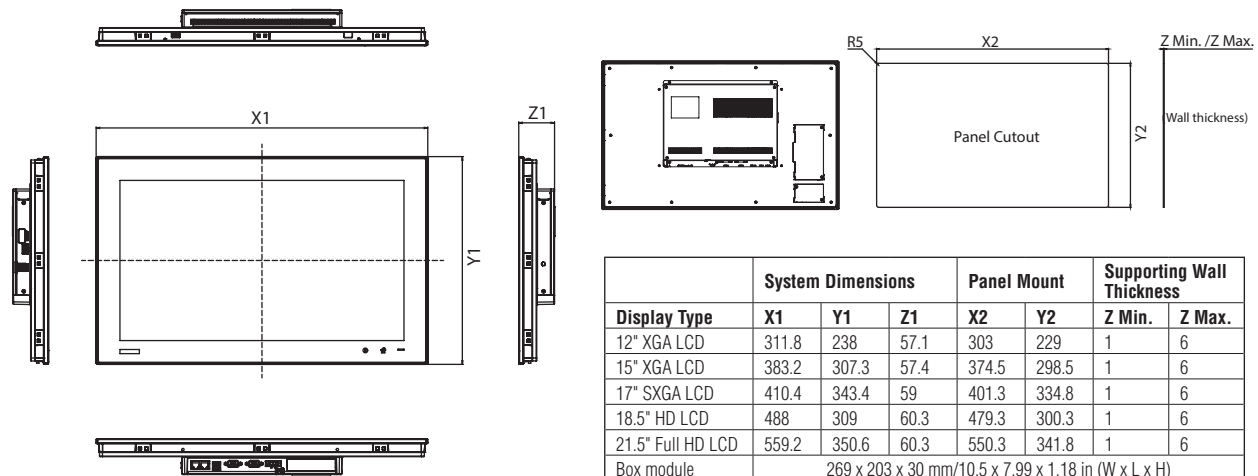

Ordering Information

Configurable System

Box Module	TPC-B200-J12AE				
Description	Intel® Celeron® J3455, 1.50 GHz, processor with 4 GB DDR3L				

Panel Module	FPM-D12T-AE	FPM-D15T-AE	FPM-D17T-AE	FPM-D18W-AE	FPM-D21W-AE
Description	12.1" XGA TFT LED LCD	15" XGA TFT LED LCD	17" SXGA TFT LED LCD	18.5" HD TFT LED LCD	21.5" Full HD TFT LED LCD

Pre-Configured System

- TPC-2121T-J12AE** Modular TPC with 12.1" XGA LCD, Intel® Celeron® J3455 quad-core (1.50 GHz) processor, 4 GB RAM, and resistive touch control
- TPC-2151T-J12AE** Modular TPC with 15" XGA LCD, Intel® Celeron® J3455 quad-core (1.50 GHz) processor, 4 GB RAM, and P-CAP touch control
- TPC-2181W-J12AE** Modular TPC with 18.5" HD LCD, Intel® Celeron® J3455 quad-core (1.50 GHz) processor, 4 GB RAM, and P-CAP touch control (available in March 2018)

Optional Accessories

- PWR-247-CE** 60W DC 24V/2.5A power adaptor
- 1702002600** Power cable (US) 1.8 M
- 1702002605** Power cable (EU) 1.8 M
- 1702031801** Power cable (UK) 1.8 M
- 1700000596** Power cable (China/Australia) 1.8 M
- TPC-5000T-VMKE** Wall mount kit for 12" to 21" modular TPC systems
- TPC-1000H-SMKE** Stand mount kit for 10" to 17" modular TPC systems
- TPC-RUSB-W10LTSBE** Win 10 IoT Ent LTSB 2016 multi language ORY Entry EPKEA
- 98R35000010** Wi-Fi module 802.11 bgn/RT5390 1T1R with USB signal
- 98R35000000** USB NFC/RFID module ADT-006

iDoor Modules

- PCM-26D2CA-AE** SJA1000 CANBus with CANOpen and 2 x DB9
- PCM-26D1DB-MAE** HiIscher netX100 with FieldBus, ProfiBus, and 1 x DB9
- PCM-27D24DI-AE** Digital I/O with 16 x DI/8 x DO, isolation, and 1 x DB37
- PCM-24D2R4-AE** OXPcie-952 UART with isolated RS-422/485 and 2 x DB9
- PCM-24D2R2-AE** OXPcie-952 UART with isolated RS-232 and 2 x DB9
- PCM-24R2GL-AE** 2-port Gigabit LAN Intel i350 PCIe mini card
- PCM-24R1TP-AE** Intel 82574L with GbE, IEEE 1588 PTP, and 1 x RJ45

* Contact Advantech for more options.

Rear View

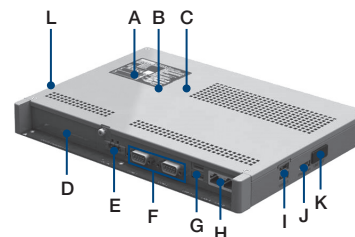

- A. Hard disk bay
- B. mPCIe
- C. M.2 (SATA only)
- D. iDoor
- E. Power input
- F. 2 x RS-232/422/485
- G. 2 x USB 3.0
- H. 2 x LAN (10/100/1000)
- I. 2 x USB 2.0
- J. DisplayPort
- K. Audio line out
- L. Antenna

Application Software

WebAccess/SCADA	Advantech WebAccess/SCADA is a 100% browser-based IIoT software platform aimed at supervisory control and data acquisition (SCADA) operations. WebAccess/SCADA provides open interfaces that allow our customers and partners to develop unique IoT applications for different vertical markets. In addition to supporting traditional SCADA functions, the platform features an HTML5-based user interface and intelligent dashboard to facilitate cross-platform, cross-browser data analysis. Moreover, WebAccess/SCADA not only offers built-in widgets, but is also equipped with an innovative Widget Builder that enables customers to build their own widgets.
WebAccess/HMI	Advantech WebAccess/HMI is human-machine interface (HMI) software based on Microsoft's Windows operating system. This software features excellent communication and monitoring capabilities, supports more than 350 PLC communication protocols, and offers a wide choice of screen design objects to satisfy diverse integrations of factory automation and HMI operation and monitoring requirements.



Компания «ЭлектроПласт» предлагает заключение долгосрочных отношений при поставках импортных электронных компонентов на взаимовыгодных условиях!

Наши преимущества:

- Оперативные поставки широкого спектра электронных компонентов отечественного и импортного производства напрямую от производителей и с крупнейших мировых складов;
- Поставка более 17-ти миллионов наименований электронных компонентов;
- Поставка сложных, дефицитных, либо снятых с производства позиций;
- Оперативные сроки поставки под заказ (от 5 рабочих дней);
- Экспресс доставка в любую точку России;
- Техническая поддержка проекта, помощь в подборе аналогов, поставка прототипов;
- Система менеджмента качества сертифицирована по Международному стандарту ISO 9001;
- Лицензия ФСБ на осуществление работ с использованием сведений, составляющих государственную тайну;
- Поставка специализированных компонентов (Xilinx, Altera, Analog Devices, Intersil, Interpoint, Microsemi, Aeroflex, Peregrine, Syfer, Eurofarad, Texas Instrument, Miteq, Cobham, E2V, MA-COM, Hittite, Mini-Circuits, General Dynamics и др.);

Помимо этого, одним из направлений компании «ЭлектроПласт» является направление «Источники питания». Мы предлагаем Вам помощь Конструкторского отдела:

- Подбор оптимального решения, техническое обоснование при выборе компонента;
- Подбор аналогов;
- Консультации по применению компонента;
- Поставка образцов и прототипов;
- Техническая поддержка проекта;
- Защита от снятия компонента с производства.



Как с нами связаться

Телефон: 8 (812) 309 58 32 (многоканальный)

Факс: 8 (812) 320-02-42

Электронная почта: org@eplast1.ru

Адрес: 198099, г. Санкт-Петербург, ул. Калинина, дом 2, корпус 4, литера А.