

AC/DC Drivers

Quasi-Resonant Control type DC/DC Converter IC

BM1Q00XFJ Series

●General Description

The quasi-resonant controller typed AC/DC converter IC (BM1Q00XFJ series) provides an optimum system for all products that include an electrical outlet. Quasi-resonant operation enables soft switching and helps to keep EMI low. With MOSFET for switching and current detection resistors as external devices, a higher degree of design freedom is achieved. As BM1Q00XFJ series built in HV starter circuit, it contributes to low consumption power and high speed start. Because the built-in burst mode is reduced switching loss and IC consumption current is low, Stand-by power is very low. Because BM1Q00XFJ series built-in soft-start, burst mode, over current limiter which is cycle-by-cycle, over load protection, over voltage protection, CS open protection and so on, BM1Q00XFJ series are highly safety.

●Key Specifications

- Operating Power Supply Voltage Range:
 - VCC : 8.9V to 26.0V
 - VH : to 600V
- Operating Current:
 - Normal : 0.60mA (Typ.)
 - Burst : 0.35mA(Typ.)
- Max frequency: 120kHz(Typ.)
- Operate temperature range: -40°C to +85°C

●Typical Application Circuit

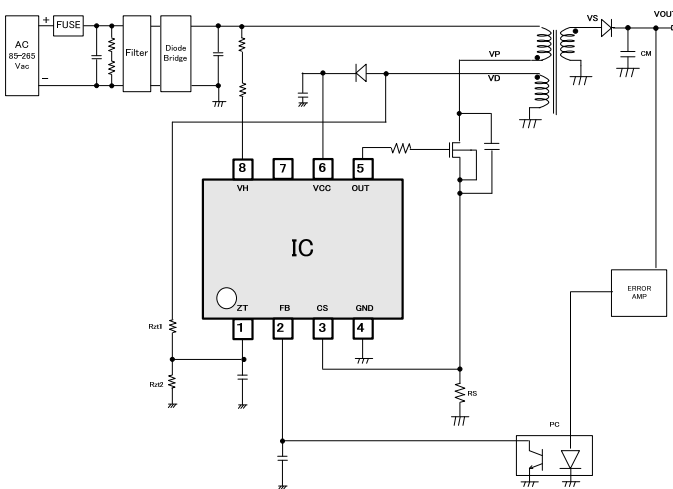

Fig 1. Application Circuit

●Features

- Quasi-resonant method
- Built-in 650V tolerate start circuit
- Low power when load is light (Burst operation)
- Maximum frequency control (120kHz)
- Frequency reduction function
- AC voltage correction function
- VCC pin : under voltage protection
- VCC pin : overvoltage protection
- Over-current protection (cycle-by-cycle)
- OUT pin : H voltage 12V clamp
- Soft start
- ZT trigger mask function
- ZT Over voltage protection
- FB Over Load protection [Auto-restart]
- CS pin open protection [Auto-restart]

●Package

SOP-J8 4.90mm × 3.90mm × 1.65mm
(Typ.) (Typ.) (Typ.)

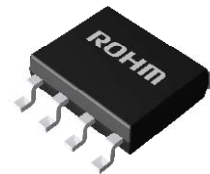

●Applications

AC adapters and household appliances (printer, TV, vacuum cleaners, air cleaners, air conditioners, IH cooking heaters etc.)

●Line Up

| IC | VCC OVP | ZT OVP |
|-----------|--------------|--------|
| BM1Q001FJ | Auto restart | None |
| BM1Q002FJ | Latch | Latch |

● Absolute Maximum Ratings (Ta=25°C)

| Item | Symbol | Rating | Unit | Condition |
|---------------------------|-------------------|---------------|------|-----------|
| Input voltage range 1 | Vmax1 | -0.3 ~ 30 | V | VCC |
| Input voltage range 2 | Vmax2 | -0.3 ~ 6.5 | V | CS, FB |
| Input voltage range 3 | Vmax3 | -0.3 ~ 7.0 | V | ZT |
| Input voltage range 4 | Vmax4 | -0.3 ~ 15 | V | OUT |
| Input voltage range 5 | Vmax5 | -0.3 ~ 650 | V | VH |
| OUT pin out peak current1 | I _{OH} | -0.5 | A | |
| OUT pin out peak current2 | I _{OL} | 1.0 | A | |
| ZT pin current1 | I _{SZT1} | -3.0 | mA | |
| ZT pin current2 | I _{SZT2} | 3.0 | mA | |
| Allowable dissipation | P _d | 674.9 (Note1) | mW | |
| Operating temperature | T _{opr} | -40 ~ +85 | °C | |
| Max junction temperature | T _{jmax} | 150 | °C | |
| Storage temperature range | T _{str} | -55 ~ +150 | °C | |

(Note1) When mounted (on 70 mm × 70 mm, 1.6 mm thick, glass epoxy on single-layer substrate).

Reduce to 5.4 mW/°C when Ta = 25°C or above.

● Operating Conditions (Ta=25°C)

| Parameter | Symbol | Rating | Unit | Conditions |
|------------------------------|--------|----------|------|------------|
| Power supply voltage range 1 | VCC | 8.9~26.0 | V | VCC |
| Power supply voltage range 2 | VH | 80~600 | V | VH |

● Electrical Characteristics (Unless otherwise noted, Ta = 25°C, VCC = 15 V)

| Parameter | Symbol | Specifications | | | Unit | Conditions |
|-----------------------------------|---------------------|----------------|-------|-------|------|---|
| | | MIN | TYP | MAX | | |
| [Circuit current] | | | | | | |
| Circuit current (ON)1 | I _{ON1} | - | 600 | 1000 | uA | FB=2.0V (Switching operation) |
| Circuit current (ON)2 | I _{ON2} | - | 350 | 450 | uA | FB=0.5V (Switching OFF) |
| Circuit current(OFF) | I _{OFF} | - | - | 25 | uA | VCC=12V, VH:open VCC UVLO = disable |
| [VH pin starter] | | | | | | |
| VH Start current1 | I _{START1} | 0.400 | 0.700 | 1.000 | mA | VCC= 0V |
| VH Start current2 | I _{START2} | 1.00 | 3.00 | 6.00 | mA | VCC=10V |
| VH OFF current | I _{START3} | - | 10 | 20 | uA | Released VCCUVLO VH pin current |
| VH start current switched voltage | V _{SC} | 0.400 | 0.800 | 1.400 | V | VCC pin |
| [VCC pin protection] | | | | | | |
| VCC UVLO voltage1 | V _{UVLO1} | 12.50 | 13.50 | 14.50 | V | VCC rise |
| VCC UVLO voltage2 | V _{UVLO2} | 7.50 | 8.20 | 8.90 | V | VCC fall |
| VCC UVLO hysteresis | V _{UVLO3} | - | 5.30 | - | V | V _{UVLO3} = V _{UVLO1} -V _{UVLO2} |
| VCC charge start voltage | V _{CHG1} | 7.70 | 8.70 | 9.70 | V | Starter circuit |
| VCC charge end voltage | V _{CHG2} | 12.00 | 13.00 | 14.00 | V | Stop voltage from V _{CHG1} |
| VCC OVP voltage1 | V _{OV1} | 26.00 | 27.50 | 29.00 | V | VCC rise |
| VCC OVP voltage2 | V _{OV2} | - | 23.50 | - | V | VCC fall [BM1Q001] |
| VCC OVP hysteresis | V _{OV3} | - | 4.00 | - | V | [BM1Q001] |
| [OUT pin] | | | | | | |
| OUT pin H voltage | V _{OUTH} | 10.5 | 12.5 | 14.5 | V | IO=-20mA, VCC=15V |
| OUT pin L voltage | V _{OUTL} | - | - | 0.30 | V | IO=+20mA |
| OUT pin Pull-down resistor | R _{PDOUT} | 75 | 100 | 125 | kΩ | |

● IC control unit Electrical Characteristics (Unless otherwise noted, Ta = 25°C, VCC = 15 V)

| Parameter | Symbol | Specifications | | | Unit | Conditions |
|--|---------------------|----------------|------------------------------|-------|------|------------------------------------|
| | | MIN | TYP | MAX | | |
| [DC/DC converter unit (Turn-off)] | | | | | | |
| Pull-up resistor of FB pin | R _{FB} | 22.5 | 30.0 | 37.5 | kΩ | FB=0V |
| CS over current voltage 1A | V _{lim1A} | 0.475 | 0.500 | 0.525 | V | FB=2.2V (ACSNS=L) |
| CS over current voltage 1B | V _{lim1B} | 0.310 | 0.350 | 0.390 | V | FB=2.2V (ACSNS=H) |
| CS over current voltage 2A | V _{lim2A} | 0.100 | 0.125 | 0.150 | V | FB=0.5V (ACSNS=L) |
| CS over current voltage 2B | V _{lim2B} | 0.062 | 0.088 | 0.113 | V | FB=0.5V (ACSNS=H) |
| Voltage gain1 (ΔVFB/ΔVCS) | AV _{CS1} | 3.40 | 4.00 | 4.60 | V/V | ACSNS=L |
| Voltage gain 2 (ΔVFB/ΔVCS) | AV _{CS2} | 4.86 | 5.71 | 6.57 | V/V | ACSNS=H |
| ZT current switched CS 1 | I _{ZT1} | 0.93 | 1.00 | 1.07 | mA | |
| ZT current switched CS 2 | I _{ZT2} | 0.82 | 0.90 | 0.98 | mA | |
| ZT current hysteresis switched CS voltage | I _{ZTHYS} | - | 0.10 | - | mA | |
| CS Leading Edge Blanking | T _{LEB} | - | 0.250 | - | us | |
| Turn-off time | T _{OFF} | - | 0.150 | - | us | |
| Minimum ON width | T _{min} | - | 0.400 | - | us | T _{LEB} +T _{OFF} |
| Maximum ON width | T _{max} | 30.0 | 39.0 | 50.7 | us | |
| [DC/DC converter unit (Turn-on)] | | | | | | |
| ZT input current 1 | I _{ZT1} | 4 | 14 | 24 | uA | OUT=L, ZT=4.65V |
| ZT input current 2 | I _{ZT2} | 6 | 16 | 26 | uA | OUT=L, ZT=5.00V |
| ZT input current 3 | I _{ZT3} | 8 | 18 | 28 | uA | OUT=L, ZT=5.35V |
| Max frequency 1 | F _{SW1} | 108 | 120 | 132 | kHz | FB=2.0V |
| Max frequency 2 | F _{SW2} | 21 | 30 | 39 | kHz | FB=0.5V |
| Frequency reduction start voltage | V _{FBSW1} | 1.10 | 1.25 | 1.40 | V | |
| Frequency reduction end voltage | V _{FBSW2} | 0.42 | 0.50 | 0.58 | V | |
| ZT comparator voltage1 | V _{ZT1} | 60 | 100 | 140 | mV | ZT fall |
| ZT comparator voltage2 | V _{ZT2} | 120 | 200 | 280 | mV | ZT rise |
| ZT trigger mask time | T _{ZTMASK} | - | 0.6 | - | us | In OUT H →L, prevent noise |
| ZT trigger Timeout1 | T _{ZTOUT1} | 10.5 | 15.0 | 19.5 | us | |
| ZT trigger Timeout2 | T _{ZTOUT2} | 3.5 | 5.0 | 6.5 | us | From final ZT trigger |
| [DC/DC protection] | | | | | | |
| Soft start time1 | T _{SS1} | 0.35 | 0.50 | 0.65 | ms | |
| Soft start time 2 | T _{SS2} | 0.70 | 1.00 | 1.30 | ms | |
| Soft start time 3 | T _{SS3} | 1.40 | 2.00 | 2.60 | ms | |
| Soft start time 4 | T _{SS4} | 2.80 | 4.00 | 5.20 | ms | |
| FB Burst voltage | V _{BURST1} | 0.42 | 0.50 | 0.58 | V | Burst ON |
| FB OLP voltage a | V _{FOLP1A} | 2.6 | 2.8 | 3.0 | V | FBOLP detect (FB rise) |
| FB OLP voltage b | V _{FOLP1B} | - | 2.6 | - | V | FBOLP detect (FB fall) |
| FB OLP delay timer | T _{FOLP} | 44.8 | 64 | 83.2 | ms | |
| FBOLP stop timer | T _{OLPST} | 358 | 512 | 666 | ms | |
| Latch released voltage (VCC pin voltage) | V _{LATCH} | - | V _{UVLO2} - 0.50 | - | V | |
| Latch mask time | T _{LATCH} | 50 | 100 | 200 | ms | |
| ZT OVP voltage | V _{ZTL} | 4.65 | 5.00 | 5.35 | V | [BM1Q002FJ] |

* Definition of ACSNS (L : ZT current < I_{ZT1} 、 H : ZT current > I_{ZT1})

● Pin Configuration

Table 1 Input-Output PIN Function

| NO. | Pin Name | I/O | Function | ESD Diode | |
|-----|----------|-----|-----------------------------|-----------|-----|
| | | | | VCC | GND |
| 1 | ZT | I | Zero current detect pin | - | ○ |
| 2 | FB | I | Feedback signal input pin | ○ | ○ |
| 3 | CS | I | Primary current sensing pin | ○ | ○ |
| 4 | GND | I/O | GND pin | ○ | - |
| 5 | OUT | O | External MOS drive pin | ○ | ○ |
| 6 | VCC | I/O | Power supply pin | - | ○ |
| 7 | N.C. | - | Non Connection | - | - |
| 8 | VH | I | Starter circuit pin | - | ○ |

● External Dimensions

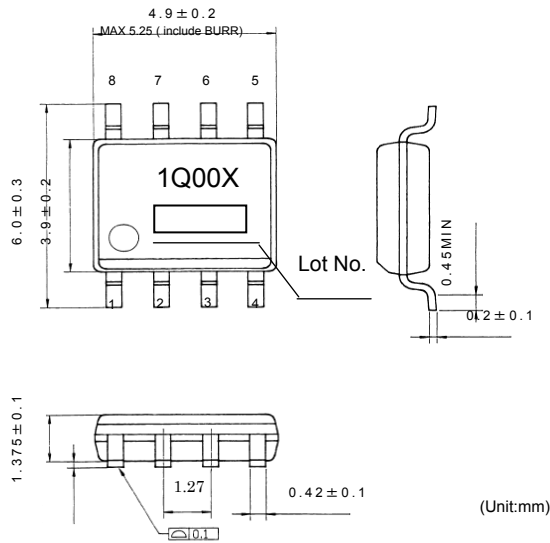

Fig-2 External Dimensions

● I/O Equivalent Circuit Diagram

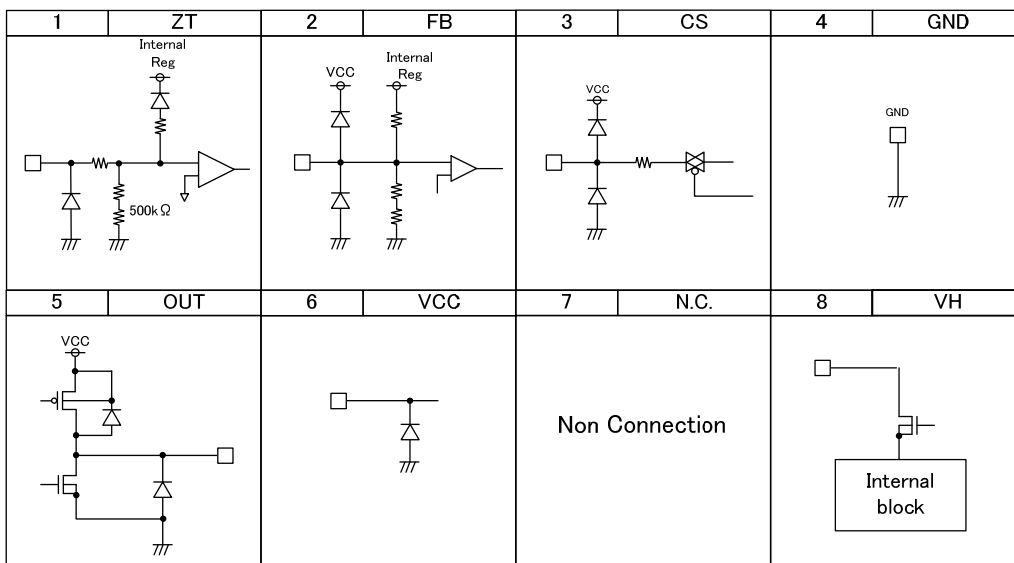

Fig-3 I/O Equivalent Circuit Diagram

●Block Diagram

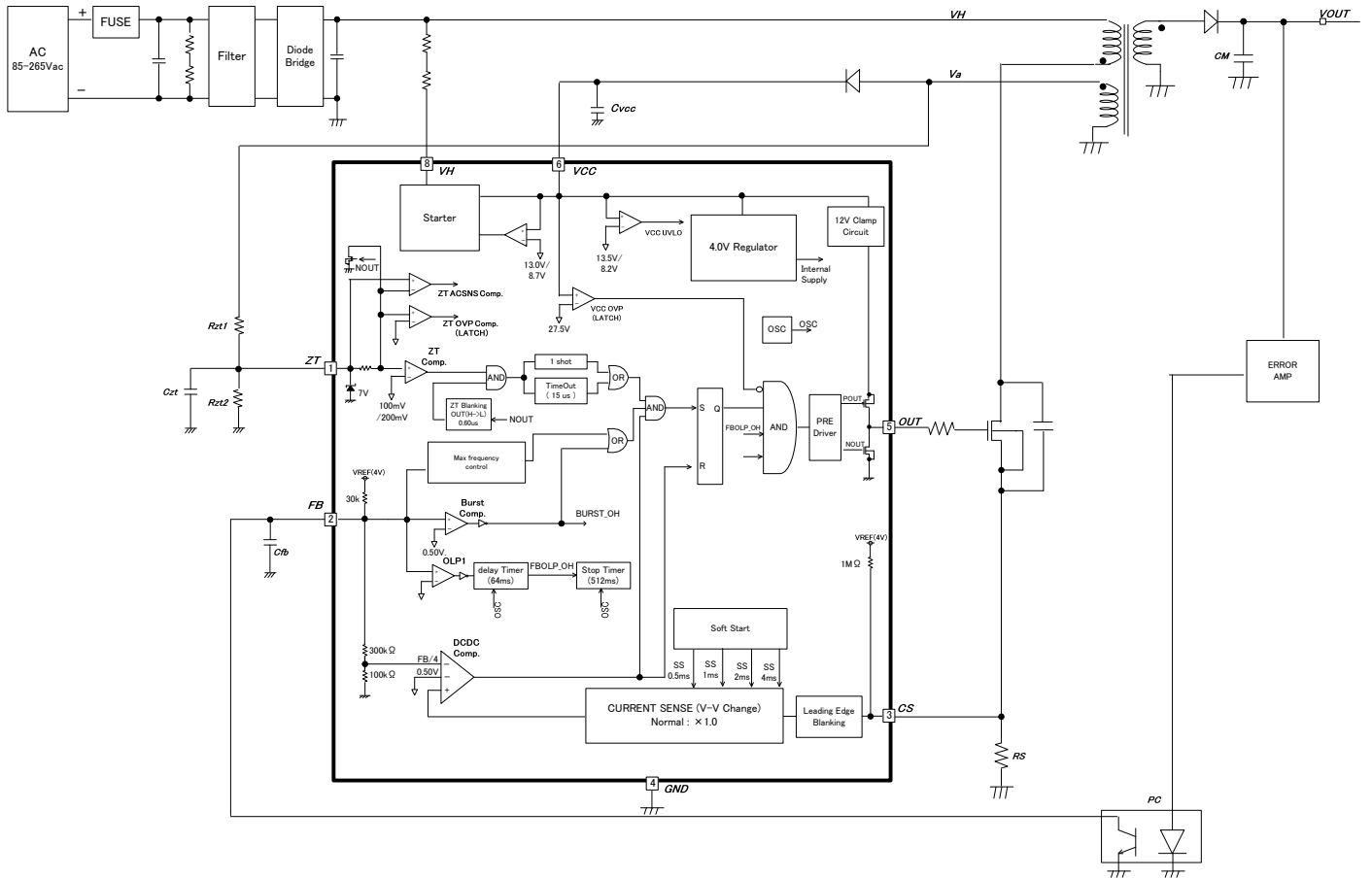

Fig-4 Block Diagram

●Description of Blocks

(1-1) Starter Circuit VH pin (8pin)

IC builds in starter circuit (tolerates 650V) to VH pin (8pin). It enables to be low standby power and high speed starting. The operating current is shown in Fig-6. After starting IC, consumption power is decided by multiplied idling current I_{START3} (typ=10uA) with VH voltage. The loss by the idling current is below.

- ex) power consumption of starter circuit only
- $V_{ac}=100V$ $Power=100V \cdot \sqrt{2} \cdot 10\mu A=1.41mW$
- $V_{ac}=240V$ $Power=240V \cdot \sqrt{2} \cdot 10\mu A=3.38mW$

Start time is decided by VH current and VCC pin capacitor.
 The reference value of start time is shown in Fig7. For example, VCC capacitor is charged within 0.1s in $C_{VCC}=10\mu F$
 When VCC pin is shorted to GND, current of "I_{START1}" flows. (Fig-6)
 When VH pin is shorted to GND, large current flows from VH line to VH pin. To prevent it, need to insert resistor (5kΩ ~60kΩ) of "R_{VH}" to limit current between VH line and VH pin.
 When VH pin is shorted to GND, the power of VH^2/R_{VH} is applied. For that, please decide resistor size to confirm power dissipation. When it does not satisfy power dissipation by one resistor, please use more than two resistors.

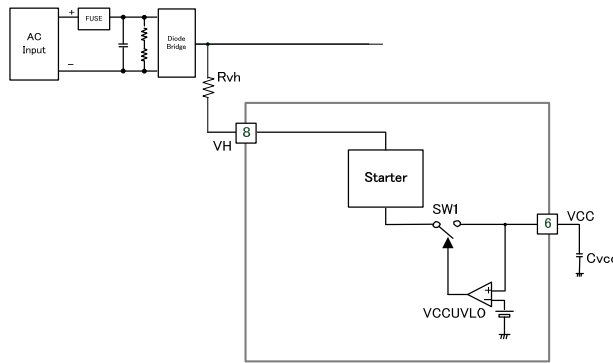

Fig-5 Starter Block Diagram

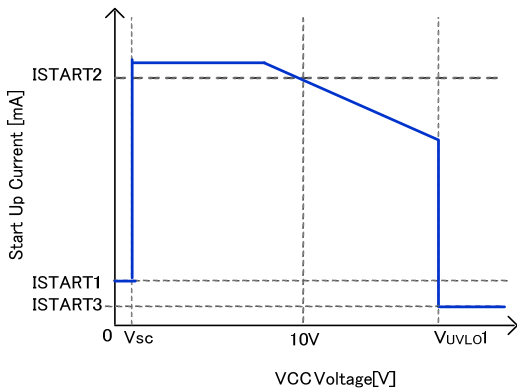

Fig-6 Start-up Current vs VCC Voltage
 *The start up current is flown from VH pin(8Pin).

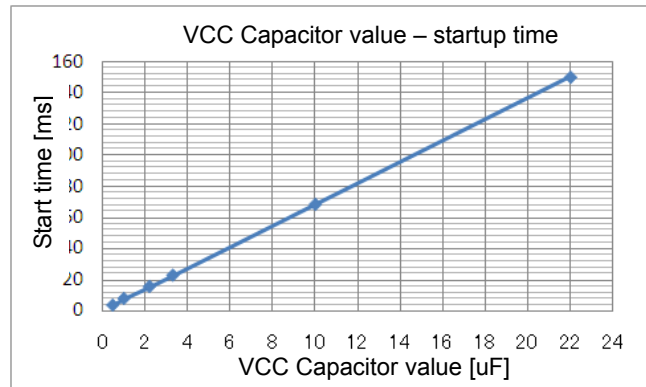

Fig-7 Start-up Time (example)

It shows operation waveform of start-up in Fig-8.

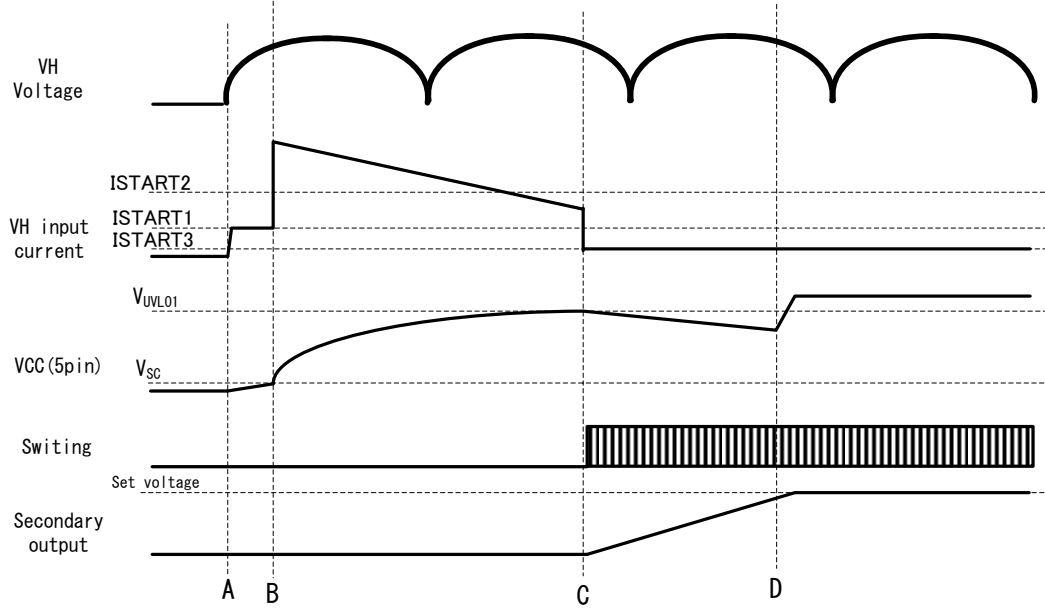

Fig-8 Start-up Waveform

- A: By inserting to outlet, VH voltage applies. From the time, charging to VCC pin starts from VH pin through starter circuit. At the time, due to $VCC < V_{sc}$ (typ=0.8V), VH input current is limited to ISTART1 by VCC pin short protection.
- B: Because of $VCC \text{ voltage} > V_{sc}$ (typ=0.8V), VCC short protection is released, the current flows from VH pin.
- C: Because of $VCC \text{ voltage} > V_{uvl01}$ (typ=13.5V), the start-up stops, and VH input current is limited to ISTART3 (typ=10uA). Furthermore, because switching operation starts, Secondary output rises. However, because Secondary output is low, VCC pin voltage is decreased. The falling rate of VCC is determined by VCC pin capacitance, the consumption current of IC and the load current that flows from the VCC pin. ($V/t = C_{vcc}/I_{cc}$)
- D: Because secondary output has risen to specific voltage, VCC pin voltage is applied from the auxiliary winding and VCC voltage is stabilized.

(1-2) In Case of Useless VH pin (8pin)

This IC is also possible to start by connecting the start-up resistor to the VCC pin in the open the start-up circuit (650V breakdown voltage) of the VH pin. The structure that do not use the recharge function is shown in Fig- 9. At start-up (before VCC VULO releasing) , please be careful to set the start-up resistor shown in blue because the consumption current I_{OFF} (Max=25uA) flows from VCC pin(6pin). Also, in case of not to use recharge function, the same circuit is used.

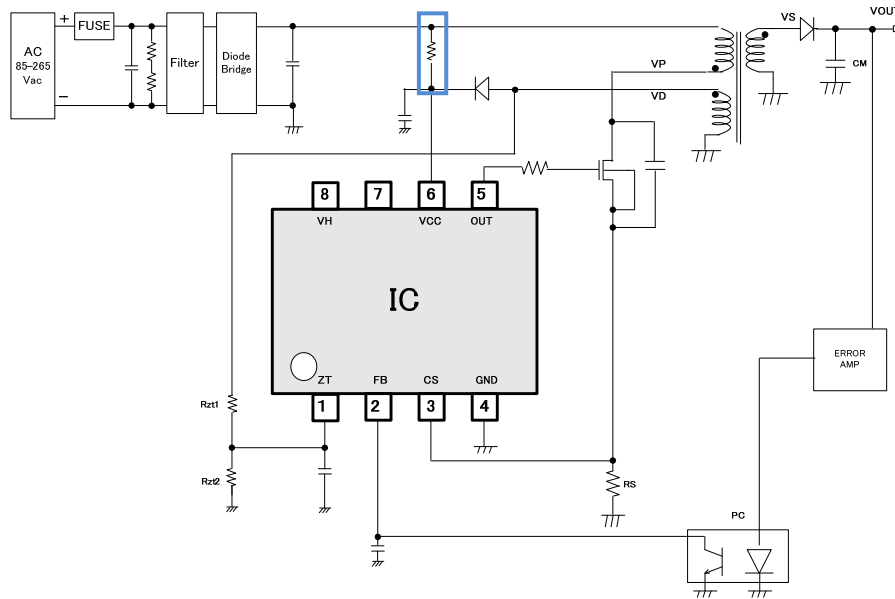

Fig-9 Application Circuit not to use VH Pin (8pin)

•How to set the start-up resistance

Start-up resistor R_{start} shown in Fig-9 in blue, is necessary for the IC to start if you do not use the VH pin. If you reduce R_{start} value, standby power is increased, start-up time is shorter. If you increase R_{start} on the contrary, standby power is reduced, start-up time will be longer. When the voltage $V_{CC}=12V$, standby current I_{OFF} is 25uA (max), V_{CC} UVLO voltage V_{UVLO1} is 14.5V (max).

ex) The example of start-up resistor R_{start} setting

$$R_{start} = (V_{min} - V_{UVLO1}(\max)) / I_{OFF}(\max)$$

In $V_{ac}=100V$, if margin is -30% , $V_{Hmin}=100 \times \sqrt{2} \times 0.7=99V$
 $V_{UVLO1}(\max)=14.5V$,so
 $R_{start} = (99-14.5) / 25\mu A=3.38M\Omega$

For an example, with a sufficient margin to 3.38MΩ, and the R_{start} is 2.0MΩ..
 For AC100V, Power consumption in R_{start} is below.
 $P_d(R_{start}) = (V_H - V_{CC})^2 / R_{start} = (141V - 14.5V)^2 / 2.0M = 8.00mW$
 P_d in using start-up resistor is more than in using VH pin,
 However for VCC pin capacitance value and VCC start-up resistor, please confirm by performing the evaluation of the actual application.

(2) Start Sequence (Soft start, Light load operation, Auto recovery in over load protection)

The start sequence of IC is shown in Fig-10. About each detail, explain in each section.

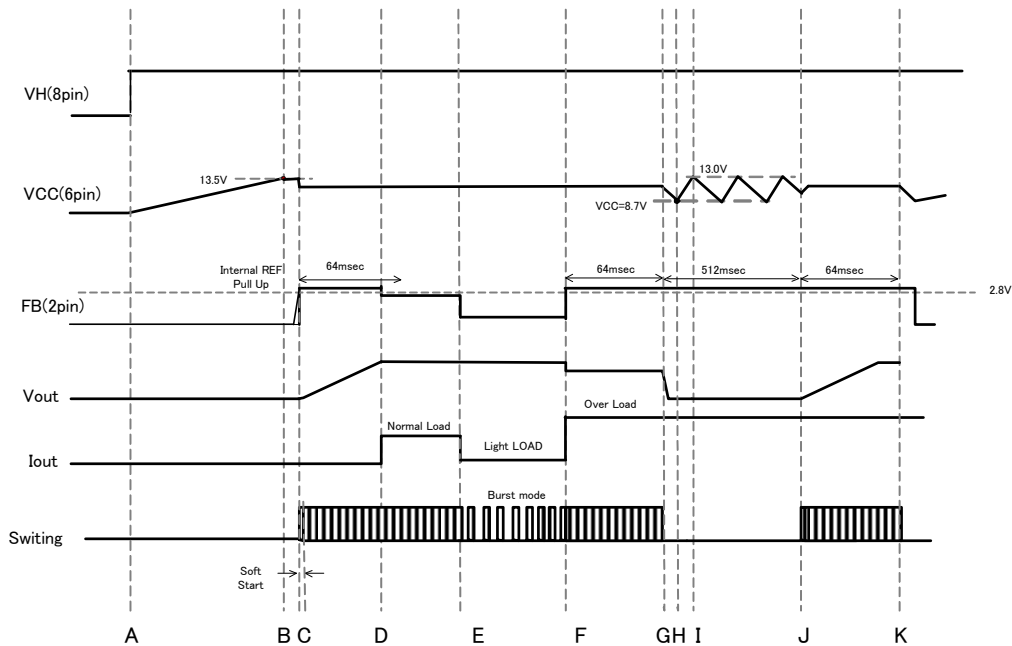

Fig-10 Start Sequence Time Chart

A: Input voltage from AC line is supplied to VH pin(8Pin).

B : VCC pin(6pin) voltage is rise, when $V_{CC} > V_{UVLO1}$ (typ=13.5V), IC starts operating.

In case of protection function is no active, IC starts to switching operation.

Then VCC pin voltage is dropped in cause of VCC (6pin) consumption current.

In case of $V_{CC} < V_{CHG1}$ (typ=8.7V), starter circuit is operated, IC starts to charge VCC pin. After starting of charge, IC continues to charge until $V_{CC} > V_{CHG1}$ (typ=13.0V).

C: There is a soft start function which regulates the voltage level at the CS pin to prevent a rise in voltage and current.

D: When the switching operation starts, VOUT rises.

Once the output voltage starts-up, set to stable the output voltage to within the T_{FOLP} (typ=64ms) period

E: When it is light load, burst operation is used to keep power consumption down.

F: When it is heavy load, FB pin voltage (2pin) is larger than V_{FOLP1A} (typ=2.8V), because output voltage is down.

G: When the FB pin(2pin) voltage keeps V_{FOLP1A} (typ=2.8V) at or above T_{FOLP} (64ms typ), switching is stopped by the over load protection for T_{OLPST} (typ=512ms).

When the FB pin(2pin) voltage does not keep V_{FOLP1B} (typ=2.6V) at T_{FOLP} (64ms typ), the timer of T_{FOLP} (typ=64ms) is reset.

H : When VCC voltage (6pin) is V_{CHG1} (typ=8.7V) or less, starter circuit starts to charge VCC pin(6pin) to operate starter circuit.

I : When VCC voltage (6pin) is over than V_{CHG2} (typ =13.0V), starter circuit stops to charge VCC pin(6pin).

J: The same as F.

K: The same as G.

(3) VCC pin(6pin) Protection Function

IC built in VCC UVLO(Under Voltage Lock Out) function and VCC OVP (Over Voltage Protection) function and VCC charge function.

VCC UVLO function is the protection for VCC (pin) voltage is low. VCC OVP function is the protection for VCC (6pin) voltage is high. They are for preventing MOSFET from destroying for switching in VCC voltage low or high.

VCC charge function is stable for output voltage in VCC pin voltage low, because starter circuit charge VCC pin from VH line.

(3-1) VCC UVLO / VCC OVP Function

VCCUVLO is an auto recovery type that has voltage hysteresis. VCCOVP is able to select an auto recovery type (BM1Q001FJ) and VCCOVP is a latch type (BM1Q002FJ).

$V_{CC} < V_{LATCH}$ (typ=7.7V) is condition of latch release (reset) after detection of latch operation by VCCOVP.

Refer to the operation figure-11.

VCCOVP built in mask time for T_{LATCH} (typ=100us). This function operates to successful detection at VCC pin voltage $> V_{OVP}$ (typ=27.5V). By this mask time, this IC masks surge etc.

In case of BM1Q001FJ (Auto recovery), When IC detects VCCOVP function, IC stops switching until VCC pin voltage is smaller than V_{OVP2} (typ=23.5V).

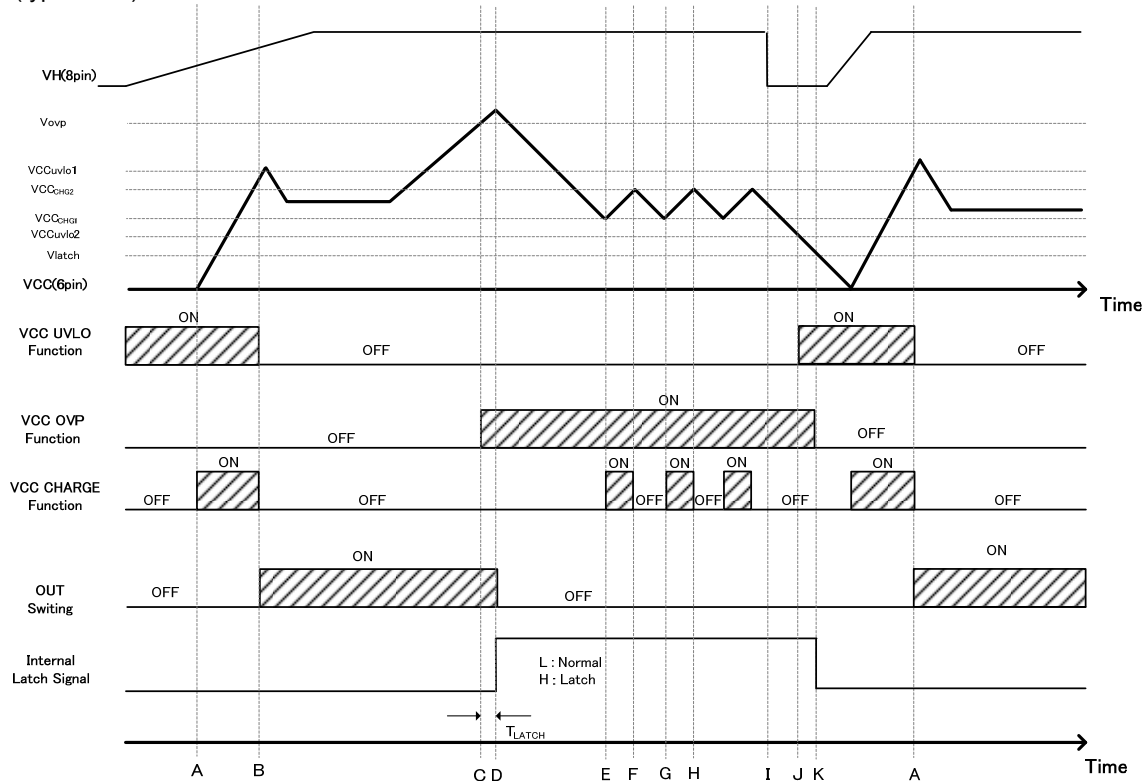

Fig-11 VCC UVLO / OVP Timing Chart

- A: VH (8pin) voltage input, VCC (6pin) voltage starts rising.
- B: VCC pin voltage $> V_{uvlo1}$, releases the VCC UVLO function and DC/DC operation starts.
- C: VCC pin voltage $< V_{uvlo2}$, VCCOVP detects the over-voltage.
- D: When the VCC (6pin) voltage $> V_{OVP}$ continues T_{LATCH} (typ =100us), switching is stopped by the VCCOVP function. (LATCH mode)
- E: VCC (6pin) voltage $< V_{CHG1}$, VCC charge function operates and the VCC pin (6pin) voltage rises.
- F: VCC (6pin) voltage $> V_{CHG2}$, VCC charge function stops.
- G: The same as E.
- H: The same as F.
- I: VH line voltage is down.
- J: $V_{CC} < V_{UVLO2}$, VCC UVLO function starts to operate.
- K: $V_{CC} < V_{LATCH}$, latch function is released.

•For Capacitor Value of VCC pin

For stable operation of the IC, please set the 1uF or higher capacitor value of VCC pin. When the VCC capacitor terminal is too large, response of the VCC pin to the Secondary output is slows down. Please be careful. If the degree of the transformer coupling is low, since a large surge occurs to the VCC pin, the IC may be destroyed. In this case, please attach a resistor which is from 10Ω to 100Ω to the path between the capacitor and diode at the back of the auxiliary winding. Please set the resistance value in order that surge of VCC pin does not exceed the absolute maximum rating of the VCC pin by performing the waveform evaluation of VCC pin.

•For settings VCC OVP voltage protection when Vout (Secondary output) is increased

VCC pin voltage is determined by the transformer ratio and Vout (Secondary output). Therefore, when the Secondary output is large, it is possible to protect IC by VCCOVP. Setting VCCOVP protection is below.

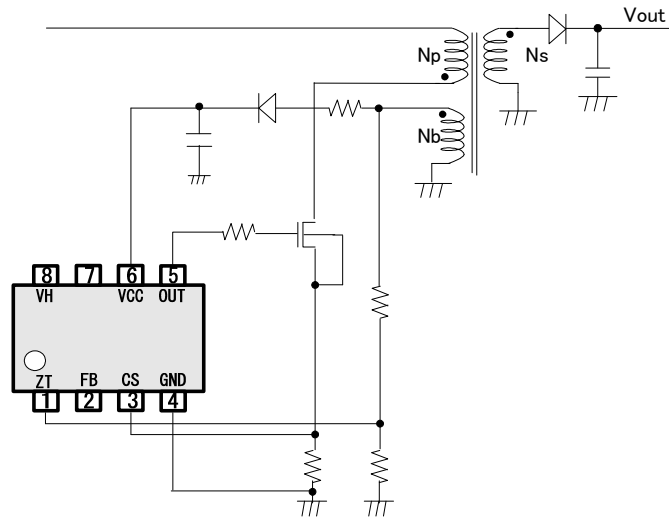

Fig-12 How to Set VCCOVP

$VCC \text{ voltage} = Vout \times Nb / Ns - VF$ (Vout:Secondary output, Nb:Number of auxiliary winding, Ns:Number of secondary winding)

If you wish to apply protection when it becomes Secondary output $\times 1.3$, please set the number of turns so that $1.3 \times (Vout \times (Nb / Ns) - VF) > VOVP1$

Because there is a blanking time of TLATCH (typ = 100us) to VCCOVP protection, VCCOVP protection is not detected to momentary surge noise of the VCC pin, However, VCCOVP is detected when VCC voltage is higher than the VOVP1 at the period of more than VTLATCH, due to low degree of transformer coupling or other influences

In addition, as a protection of Secondary output, ZTOVP is also available. ZTOVP is described in (6).

(3-2)VCC Recharge Function

After VCC (6pin) voltage > V_{UVLO1} , IC start to operate. After that, when VCC pin voltage < V_{CHG} , VCC charge function is active. Then starter circuit operates charge VCC (6pin) from VH line. By these, IC does not occur. The operation is shown to Figure-13.

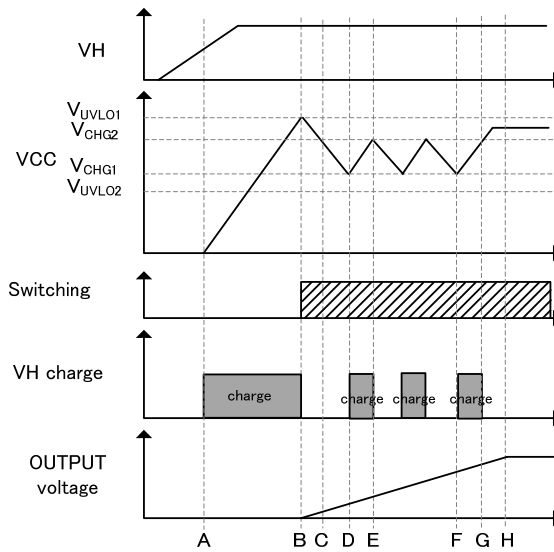

Fig-13 VCC pin Charge Operation

- A :As VH pin voltage(8pin)is rising, VCC pin(6pin) is started to charge by VCC charge function.
- B: VCC pin (6pin) voltage > V_{UVLO1} , VCC UVLO function is released, VCC charge function is stopped, DC/DC operation start.
- C: VCC pin (6pin) voltage is dropped for starting operation because OUTPUT voltage is low.
- D: VCC pin (6pin) voltage < V_{CHG1} , VCC pin(6pin) voltage rises to operate charge function.
- E: VCC pin (6pin) voltage > V_{CHG2} , VCC charge function stops.
- F: VCC pin (6pin) voltage < V_{CHG1} , VCC pin (6pin) voltage rises to re-operate charge function.
- G: VCC pin (6pin) voltage > V_{CHG2} , VCC charge function stops.
- H: OUTPUT voltage is stable. Then, VCC pin (6pin) voltage is also stable for charging from the auxiliary winding to VCC pin(6pin).

(4) DC/DC Driver

The IC operates PFM (Pulse Frequency Modulation) mode method.

By monitoring FB pin(2pin) and ZT pin (1pin), CS pin(3pin), the IC supply optimum system for DC/DC operation.

The IC controls ON width (Turn Off) of external MOSFET by FB pin (2pin) and CS pin (3pin). The IC controls OFF width (Turn ON) of external MOSFET by ZT pin(1pin). The detail is shown below.

(4-1) For QR-basic Operations

The QR basic block diagram and the basic operation are shown in Fig-14,15.

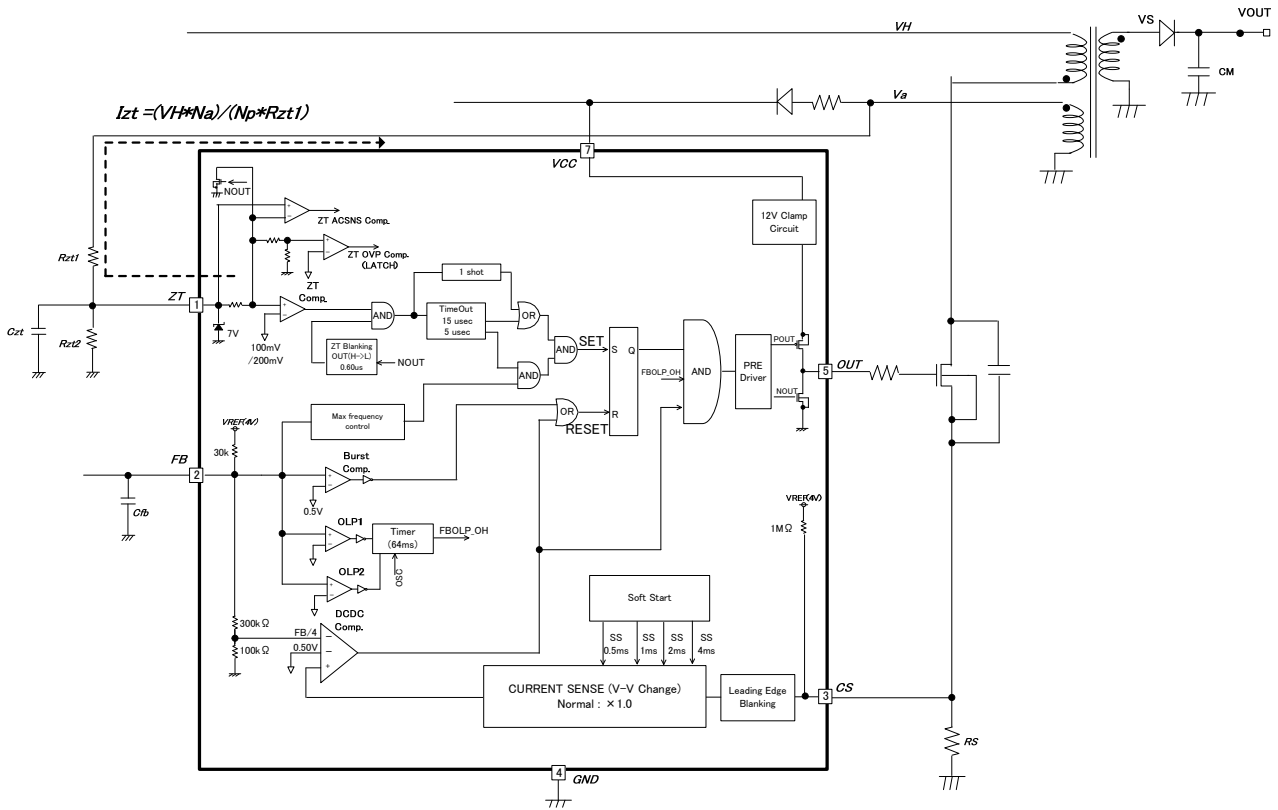

Fig-14 DC/DC Operation Block

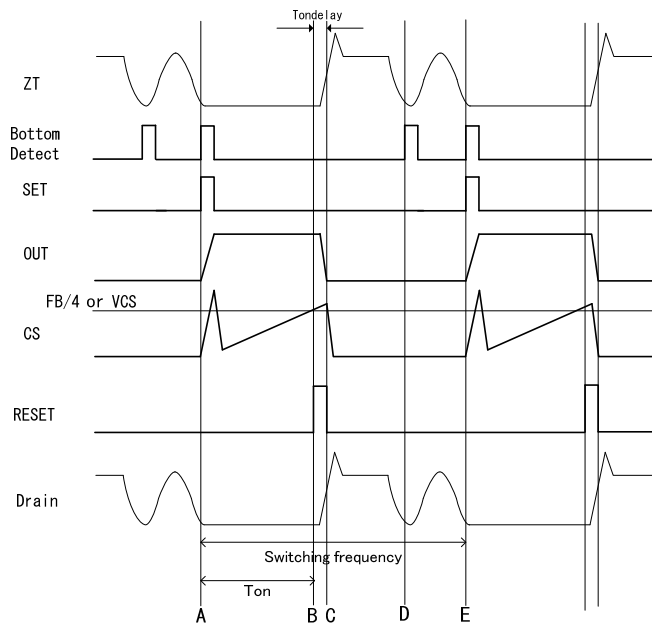

Fig-15 QR Basic Operation

For Fig-15

- A: The internal oscillator outputs the SET signal, and turns ON the MOSFET.
At this time, the Drain - source capacitance of the MOSFET is discharged, so noise is generated to the CS pin.
This noise is called Leading Edge.
The filter for this noise is built in this IC. (It refer to (4-3))
Minimum pulse width of the IC is a 400ns (typ) by this filter and the delay time.
After that, current flows through the MOSFET, and Voltage $V_{cs} = R_s * I_p$ is applied to the CS pin.
- B: If CS pin voltage rises than FB pin voltage/Gain (typ = 4) or the overcurrent detection voltage V_{cs} , RESET signal is output, OUT turns OFF
- C: There is a delay time $T_{ondelay}$ from the point of B to turn OFF actually. Because of Tondelay the difference occurs in the maximum power by the AC voltage. This IC has a built-in function to reduce this difference. (It refer to (4-4))
- D: The energy stored in the transformer during T_{on} is discharged to the secondary side, and Free vibration of the Drain voltage caused by the C_{ds} (Drain - source capacitance) of MOSFET and L_p (transformer value) begins.
- E: Since the switching frequency is determined by the IC.
SET signal is output from the internal oscillator and turn ON the MOSFET by process of certain time from A.

(4 -2) Determination of ON Width(Turn OFF)

ON width is controlled by FB (2pin), CS (3pin).
By comparison between FB pin voltage divided by AV_{cs} (typ=4) and CS pin voltage, the IC decides ON width.
Besides, by comparison with V_{lim1} (typ =0.5V) voltage which is generated in IC, CS comparator level is changed linearly to be shown in Fig-16(bottom). Maximum frequency also changes at this time.
CS (3pin) is shared with over current limiter circuit by pulse.
IC is changed over current limiter level and max frequency by FB (2pin) voltage.

- mode1 : Burst operation
- mode2 : Frequency reduction operation(reduce max frequency)
- mode3 : Max frequency operation (120kHz)
- mode4 : Over load operation (To detect over load state, IC is stopped switching)

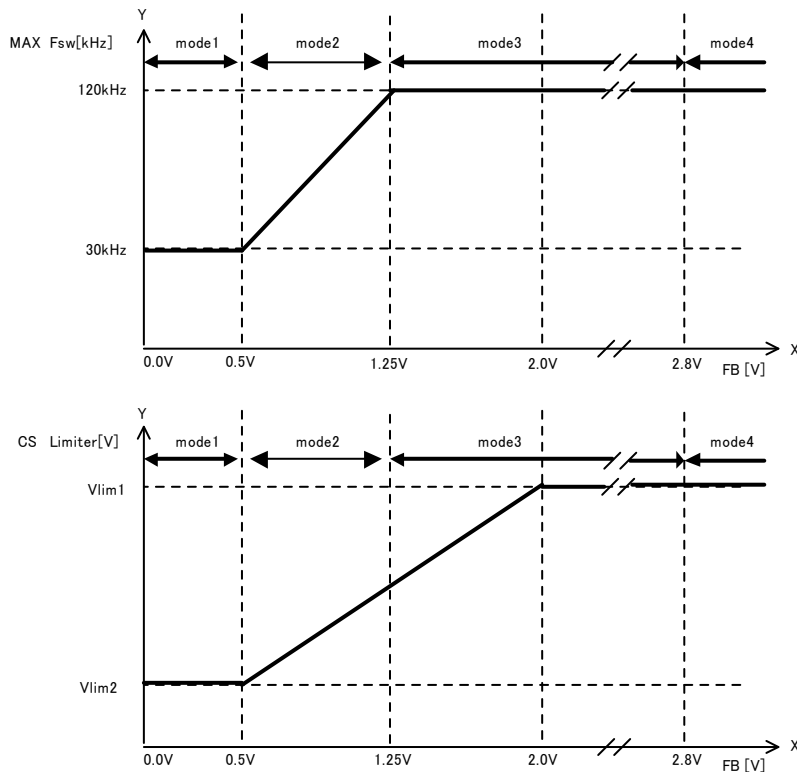

Fig-16 FB pin Voltage - Over Current Limiter, Max Frequency Characteristics

The ON width of "Ton" is decided by CS Limiter level "VCS"

$$T_{on} = (L_p \cdot V_{cs}) / (V_{in} \cdot R_s)$$

L_p: primary inductance value, V_{in} :VH voltage in Fig-14, R_s: Sense resistor in Fig-14

To adjust over current limiter level, CS over current protection voltage is switched in soft-start, AC voltage. Vlim1 and Vlim2 is changed below.

Table2 Over current protection voltage Detail

| Soft start | AC=100V | | AC=230V | |
|-------------|---------------|--------------|--------------|---------------|
| | Vlim1 | Vlim2 | Vlim1 | Vlim2 |
| start~0.5ms | 0.063V (12%) | 0.016V (3%) | 0.044V (10%) | 0.011V (2%) |
| 0.5ms~1ms | 0.125V (25%) | 0.032V (6%) | 0.088V (20%) | 0.022V (4%) |
| 1ms~2ms | 0.250V (50%) | 0.063V (12%) | 0.175V (40%) | 0.044V (9%) |
| 2ms~4ms | 0.375V (75%) | 0.094V (19%) | 0.263V (60%) | 0.066V (13%) |
| 4ms~ | 0.500V (100%) | 0.125V (25%) | 0.350V (70%) | 0.088V (18%) |

* (percent) is shown comparative value with Vlim1 (typ =0.5V) in normal operation.

The reason that distinguish between AC100V and AC230V is by CS over current protection voltage switch function which is shown to(4-4).

(4-3) LEB(Leading Edge Blanking) Function

When a MOSFET for switching is turned ON, surge current occurs in cause of capacitance or rush current. Therefore, when CS (3pin) voltage rises temporarily, over current limiter circuit may miss detections. To prevent miss detections, the IC build-in blanking function which mask for T_{LEB} (typ=250ns) from switching OUT pin(5pin) from L to H. This blanking function enables to reduce noise filter of CS pin(3pin). However, when CS pin noise does not converge less than 250ns, need to attach RC filter to CS pin shown in Fig-17. Then, delay time occurs to CS pin detection by RC filter. Also, even if the filter in not attached, it is recommended that it is attached an R_{cs} resistor to CS pin as surge provision. R_{cs} recommended resistor value is about 1kΩ.

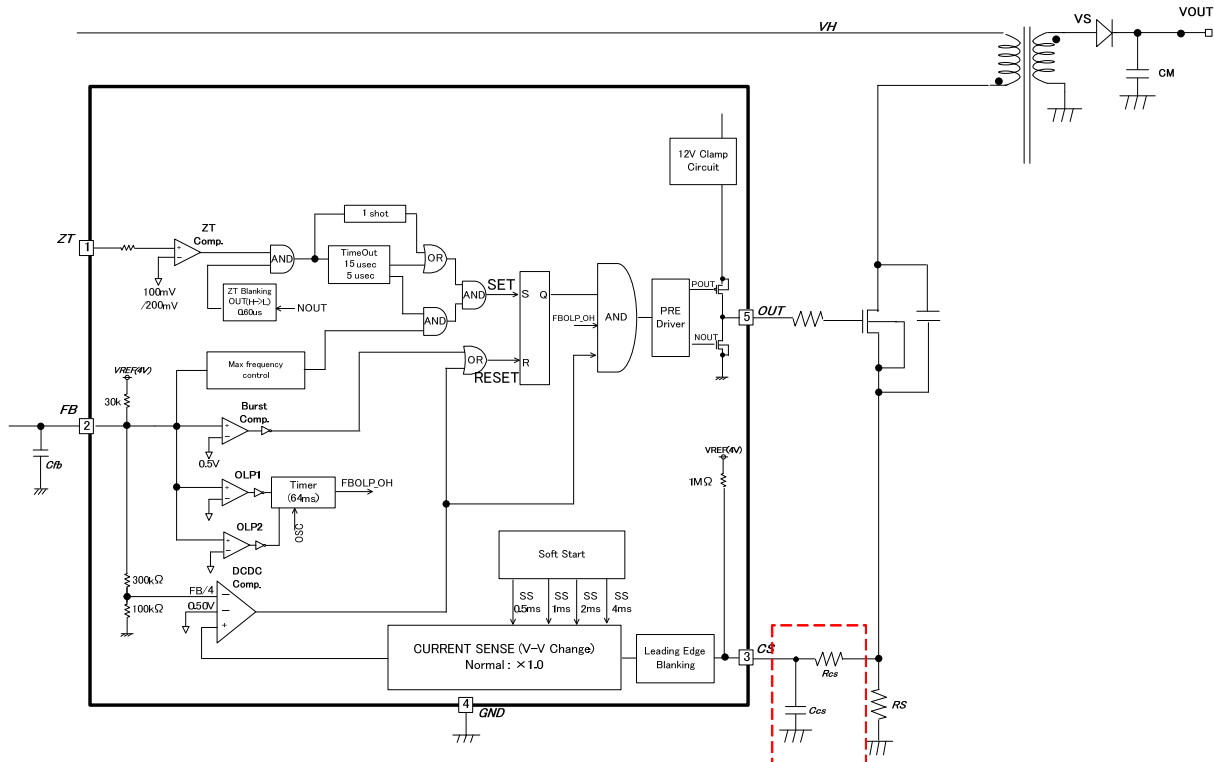

Fig-17. CS pin surrounding circuit

(4-4) CS Over Current Protection Switching Function

When input voltage (VH) is higher, ON time is short, and the operating frequency increases. As a result, maximum capable power increases for constant over current limiter. For that, monitoring input voltage (VH), IC switches over current detection of IC.

In case of high voltage (AC230V), IC changes over current comparator level to ×0.7 multiple of normal level.

The detection method is that IC monitors ZT input current, then, IC switches it. When MOSFET turns on, the voltage of “Va” has negative voltage to be affected input voltage (VH). Then, ZT (1pin) voltage is clamped near 0V by IC, ZT pin flows current to bias coil. The calculation is below. And show block figure to Fig-18, show graph to Fig-19, Fig-20.

$$I_{zt} = (V_a - V_{zt}) / R_{zt1} \doteq V_a / R_{zt1} = V_H * N_a / N_p / R_{zt1}$$

$$R_{zt1} = V_a / I_{zt}$$

Please set ZT current” Izt” to select the resistor Rzt1. And set bottom” detection timing to select Czt. About ZT current, IC builds in ZT current hysteresis IZTHYS(typ=0.1mA) to prevent VH detection changing by input voltage.

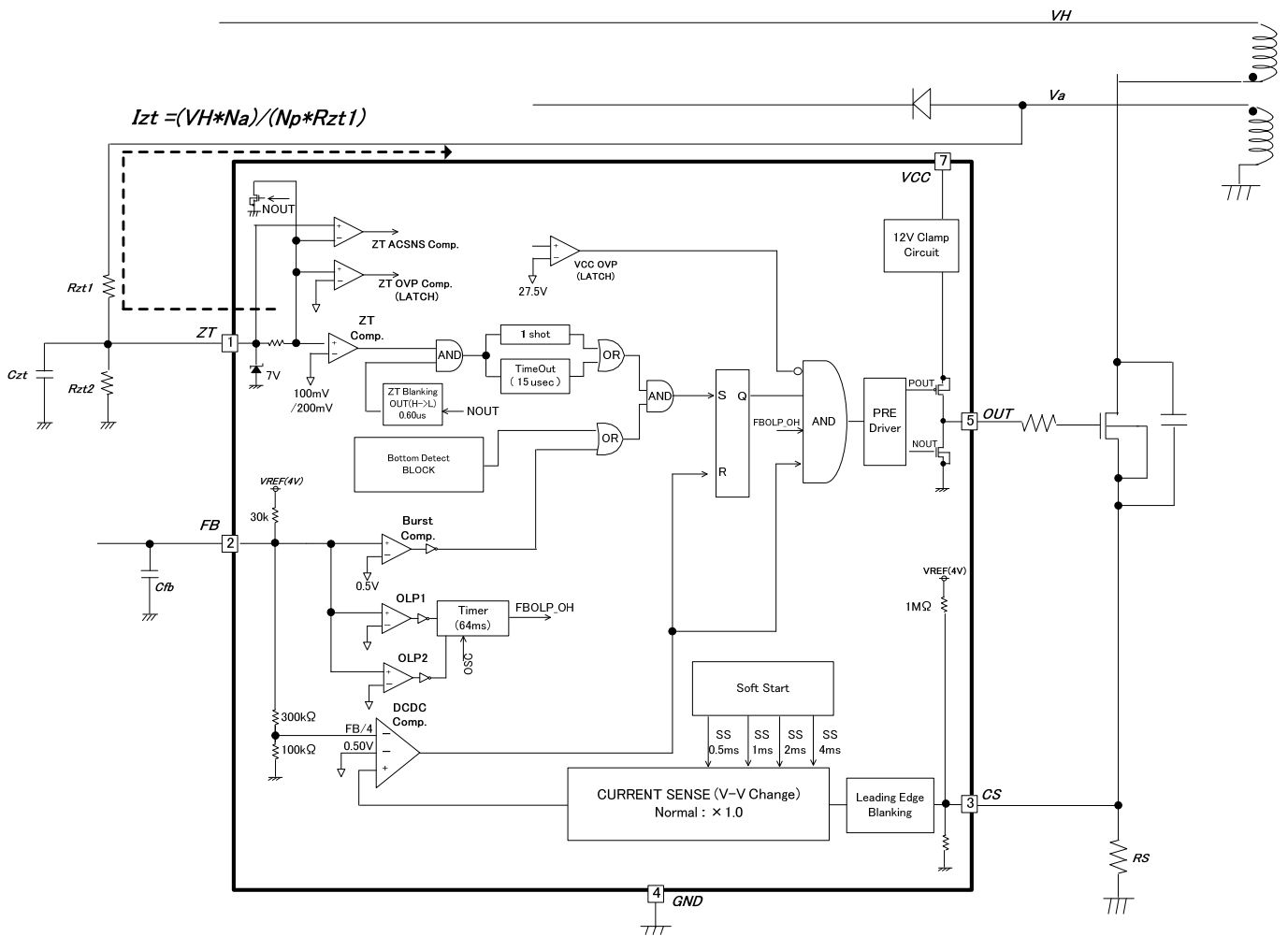

Fig-18 CS Over Current Detection Switched ZT current block diagram

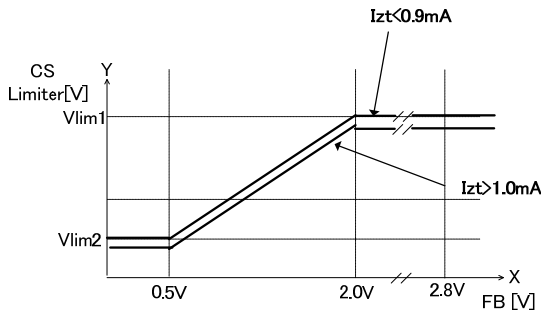

Fig-19 FB pin Voltage vs CS pin Voltage Characteristics

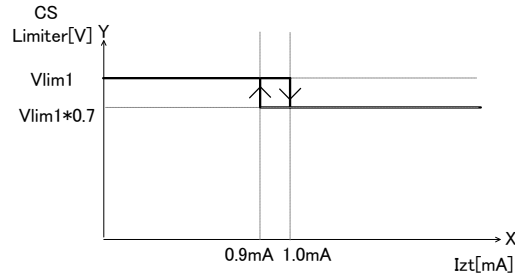

Fig-20 Izt Current vs Switched CS Voltage Characteristics

ex) setting method (Switching between AC100V and AC220V)

AC100V: 141V±42V (±30% margin)

AC220V: 308V±62V (±20% margin)

In above case, need to switch CS over current detection voltage from 182V to 246V.

For that, switching VH voltage from AC100V to AC220V may be selected in VH=214V.

Setting Np=100, Na=15

$$Va = Vin * Na / Np = 214V * 15 / 100 * (-1) = -32.1V$$

$$Rzc = Va / I_{ZT} = -32.1V / -1mA = 32.1k\Omega$$

Therefore, set to Rzt=32KΩ

$$\text{Then, switching from AC220V to AC100V is : } Va = R_{ZC} * I_{ZT} = 32k\Omega * -0.9mA = -28.8V.$$

$$\text{In the case, } Vin = Va * Np / Na = -28.8 * (100/15) * (-1) = 192V$$

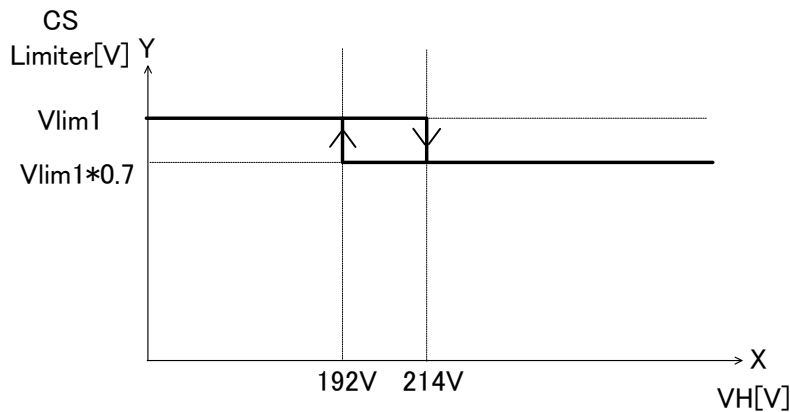

Fig-21 CS switching example VH voltage - CS voltage characteristics

(4-5) Determination of OFF Width (Turn on)

OFF width is controlled at the ZT pin. When OUT is Low, the power stored in the coil is supplied to the secondary-side output capacitor. When this power supply ends, there is no more current flowing to the secondary side, so the drain voltage of switching MOSFET drops. Consequently, the voltage on the auxiliary winding side also drops. A voltage that was resistance-divided by Rzt1 and Rzt2 is applied to ZT pin. When this voltage level drops to V_{ZT1} (100 mV typ) or below, MOSFET is turned ON by the ZT comparator. Since zero current status is detected at the ZT pin, time constants are generated using Czt, Rzt1, and Rzt2.

However, since Rzt1 and Rzt2 setting is required in AC voltage compensation function and ZTOVP function, bottom time adjustment is set in Czt capacitor.

OFF time is calculated below equation:

$$Toff1 = Ls / (Vout + VF) * Is \quad (Toff1 : \text{transformer discharge time, } Ls : \text{secondary inductance, } Vout : \text{Secondary output, } VF : \text{secondary diode forward voltage, } Is : \text{secondary peak current})$$

For that, switching frequency is calculated below:

$$\text{switching frequency} = 1 / \{ \text{transformer charge and discharge time} (Ton + Toff1) + (\text{bottom-1/2}) * \text{resonant time} \}$$

$$\text{resonant time} = 1 / (2 * \pi * Lp * Cds)$$

* Lp: primary inductance, MOSFET D-S capacitor: Cds

Because frequency reduction range in light load restricts shown Fig-16, bottom detection operates by the frequency which is lower than max frequency function in Fig-16.

Additionally, a ZT trigger mask function (described in section 4-6) and a ZT timeout function (described in section 4-7) are built in IC.

(4-6) ZT Trigger Mask Function (Fig-22)

When switching is set from ON to OFF, superposition of noise may occur at the ZT pin. Then, the ZT comparator and ZTOVP comparator are masked for the T_{ZTMASK} time to prevent ZT comparator operation errors.

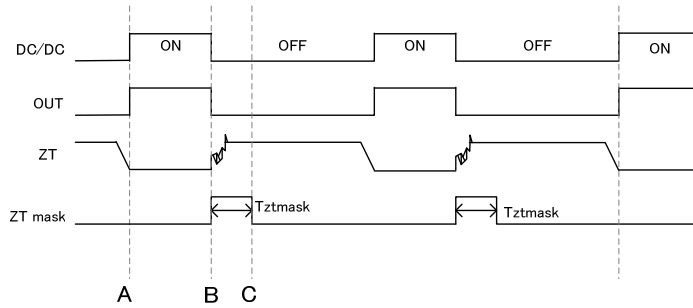

Fig-22 ZT Trigger Mask Function

- A: DC/DC OFF=>ON
- B: DC/DC ON=>OFF then the surge noise occurs to ZT pin.
- C: Since a noise occurs to ZT pin at B, IC masks ZT comparator and ZTOVP comparator detection for T_{ZTMASK} time.

(4-7-1) ZT Timeout Function1 (Fig-23)

When ZT pin voltage is not higher than V_{ZT2} (typ=200mV) for T_{ZTOUT1} (typ=15us) such as start or low output voltage, ZT pin short, IC turns on MOSFET by force.

(4-7-2) ZT Timeout Function2 (Fig-23)

After ZT comparator detects bottom, when IC does not detect next bottom within T_{ZTOUT2} (typ =5us), IC turns on MOSFET by force. After ZT comparator detects bottom at once, the function operates. For that, it does not operate at start or at low output voltage. When IC is not able to detect bottom by decreasing auxiliary winding voltage, the function operates.

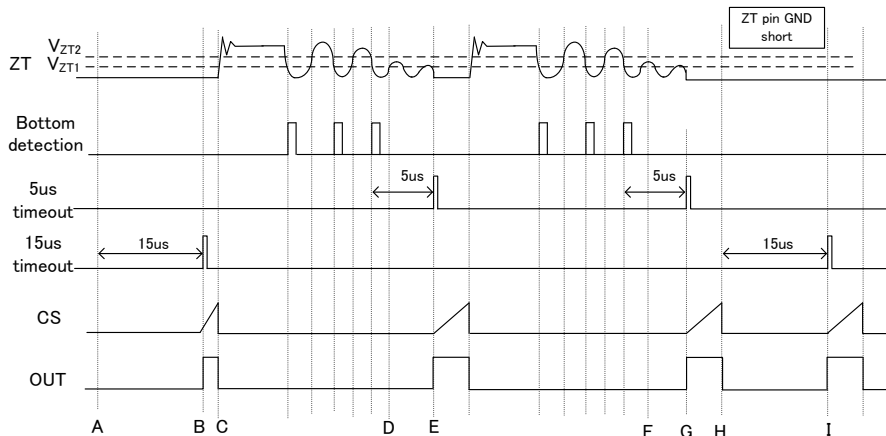

Fig-23 ZT Timeout Function

- A: When starting, IC starts to operate by ZT timeout function1 for $ZT=0V$.
- B: MOSFET turns ON
- C: MOSFET turns OFF
- D: ZT voltage is lower than V_{ZT2} (typ=200mV) by ZT dump decreasing.
- E: MOSFET turns ON by ZT timeout function2 after T_{ZT2} (typ=5us) from D point.
- F: ZT voltage is lower than V_{ZT2} (typ=200mV) by ZT dump decreasing.
- G: MOSFET turns ON by ZT timeout function2 after T_{ZT2} (typ=5us) from F point.
- H: ZT pin is short to GND.
- I: MOSFET turns ON by ZT timeout function1 after T_{ZTOUT1} (typ=15us)

(5) Soft Start Sequence

Normally, when AC voltage is applied, a large current flows. Then secondary output voltage and current is occurred overshoot. For preventing it, IC built in soft-start function.
 When VCC pin(6pin) voltage is lower than V_{UVLO2} (typ =8.2V), IC is reset. After that, when AC voltage is applied, IC operates soft-start.

The soft start function is below: (Please refer to (4-1) turn off item about CS limiter.)

- start ~ 0.5ms => Set CS limiter to 12.5% of normal operation.
- 0.5ms~1ms => Set CS limiter to 25% of normal operation.
- 1ms~2ms => Set CS limiter to 50% of normal operation.
- 2ms~4ms => Set CS limiter to 75% of normal operation.
- 4ms~ => normal operation

(6) ZT pin (1pin) OVP (Over Voltage Protection)

IC build-in OVP function to ZT (1pin). It is latch type in BM1Q002, and none in BM1Q001.
 ZTOVP operates by DC voltage detection and pulse detection for ZT pin.

[BM1Q002]

When ZT pin(1pin) voltage is over V_{ZTL} (typ=5.0V), IC starts to detect ZTOVP function.
 For DC voltage detection, when the state which ZT voltage is larger than V_{ZTL} (typ=5.0V) continues for 100us, IC carries out latch stop.

To prevent ZT (1pin) OVP from miss-detecting by surge noise, IC builds in 3count and T_{LATCH} (typ=100us) timer.

ZT (1pin) OVP function operates in all states (normal state and over load state and burst state).

For pulse detection, ZT (1pin) OVP operation starts detection after T_{ZTMASK} delay time from OUT:H→L.

When the pulse of ZT (1pin) voltage larger than V_{ZTL} (typ=5.0V) is applied 3 count and for T_{LATCH} (typ=100us)time, IC carries out latch stop.

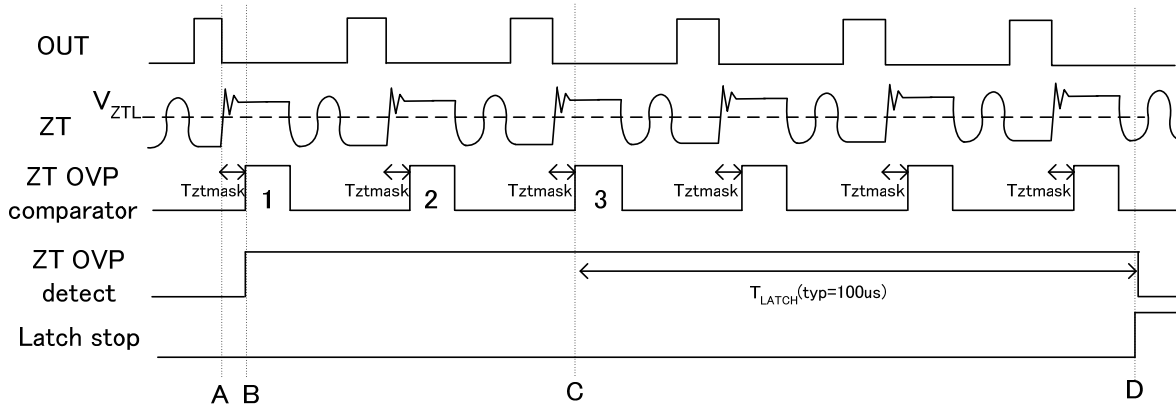

Fig-24 ZTOVP and Latch Blanking Function

- A: When OUT (5pin) voltage is changed from H to L, ZT (1pin) voltage is up. Then, surge pulse occurs to ZT (1pin). For that, because IC builds in T_{ztmask} time (typ=0.6us), IC does not detect ZTOVP for T_{ztmask} time.
- B: After T_{ztmask} time (typ=0.6us), ZT OVP detects over voltage.
- C: When ZTOVP comparator counts 3 pulse, T_{LATCH} timer (typ=100us) operates.
- D: When it takes for 100us from C, IC detects ZT OVP and IC carries out latch stop.

[BM1Q001]

BM1Q001 does not carry out latch stop.

It shows ZT OVP voltage setting method below. (auxiliary winding voltage : V_a , ZT upper resistor : R_{zt1} , ZT lower resistor : R_{zt2})

Secondary voltage : V_o , transformer winding ratio(secondary / auxiliary) : N_s/N_a , ZT input current : I_{zt}

The voltage which detects over voltage protection in secondary side : $VOVP$

$$VOVP = (N_a/N_s) * V_a = (N_a/N_s) * \{V_{ZT} * (R_{zt1} + R_{zt2}) / (R_{zt2} + R_{zt1} * I_{zt})\}$$

When ZT voltage = 5.35V, ZT input current is calculated to $I_{zt(max)}=28\mu A$, OVP maximum voltage is set below:

$$VOVP(max) = (N_a/N_s) / \{5.35 * (R_{zt1} + R_{zt2}) / (R_{zt2} + R_{zt1} * 28\mu A)\}$$

R_{zt1} setting is decided by AC voltage compensation function of (4-3).

R_{zt2} setting is calculated below

$$R_{zt2} = V_{ztovp} * R_{zt1} / \{V_{ovp} * (N_a/N_s) - I_{zt} * R_{zt1} - V_{ztovp}\}$$

When ZT voltage=5.35V, $I_{zt(max)}=28\mu A$. Then OVP voltage Max value is calculated below :

$$VOVP = (N_a/N_s) / \{5.35 * (R_{zt1} + R_{zt2}) / (R_{zt2} + R_{zt1} * 28\mu A)\}$$

(7) CS (3pin) Open Protection

When CS (3pin) is OPEN, to prevent OUT pin from changing to H by noise, IC builds in CS(3pin) open protection. When CS (3pin) is open, OUT (5pin) switching is stopped by the function. (This is auto-recovery)

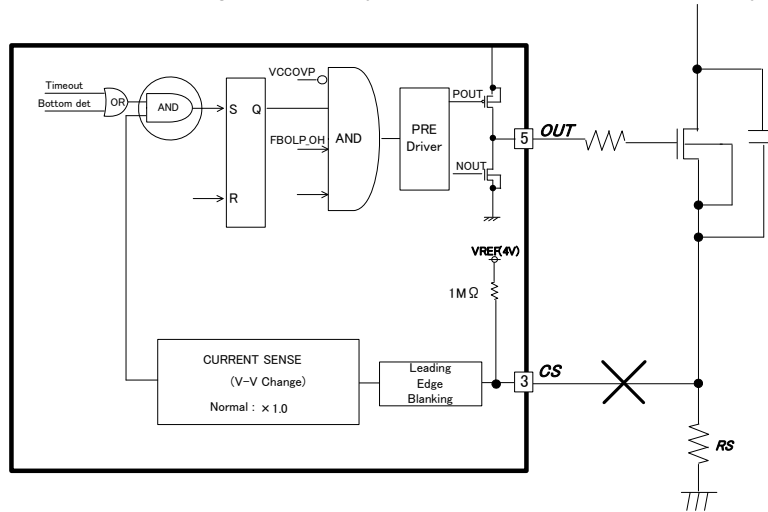

Fig-25 CS Open Protection

(8) OUTPUT Over Load Protection (FB OLP comparator)

When secondary output is over load, IC detects it by FB (2pin), IC stops switching. In OLP state, because secondary photo-coupler is not flown current, FB (2pin) voltage is up. When the condition continues for T_{FOLP} (typ =64ms), IC judges over load state, OUT (5pin) is L fixed. After FB (2pin) voltage is over V_{FOLP1A} (typ =2.8V), when FB (2pin) voltage is lower than V_{FOLP1B} (typ =2.6V) within T_{FOLP} (typ =64ms), over load protection timer is reset. In starting, because FB (2pin) is pull-up by a resistor to internal voltage, FB (2pin) voltage starts to operate in the state which is more than V_{FOLP1A} (typ =2.8V). For that, please set stable time of secondary output voltage within T_{FOLP} (typ =64ms). After detecting over load, IC is stopped for T_{OLPST} (typ =512ms), IC is auto-recovery operation. In stopping switching, though VCC (6pin) voltage falls, but IC operates re-charge function by starter circuit, VCC (6pin) voltage keeps VCC pin voltage > V_{UVL02} .

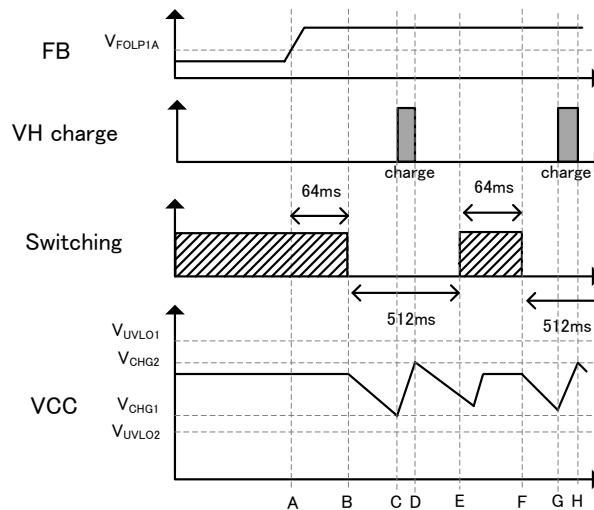

Fig-26 Over Load Protection : Auto-recovery

- A: When FB voltage is over V_{FOLP1A} (typ=2.8V), FBOLP comparator detects over load.
- B: When the state A continues for T_{FOLP} (typ=64ms), IC stops switching by over load protection.
- C: During stopping switching by over load protection, VCC (6pin) voltage drops. When VCC (6pin) voltage is lower than V_{CHG} , VCC re-charge function operate, VCC (6pin) voltage is up.
- D: When VCC (6pin) voltage is higher than V_{CHG2} by re-charge function, VCC recharge function is stopped.
- E: From B, it takes for T_{OLPST} (typ =512ms), IC starts switching with soft-start.
- F: When over load state continues, FB (2pin) voltage is over V_{FOLP1A} . When it takes for T_{FOLP} (typ=64ms) from E, IC stops switching.
- G: During stopping switching by over load protection, VCC (6pin) voltage drops. When VCC (6pin) voltage is lower than V_{CHG} , VCC re-charge function operate, VCC (6pin) voltage is up.
- H: When VCC (6pin) voltage is higher than V_{CHG2} by re-charge function, VCC recharge function is stopped.

(9) OUT (5pin) Voltage Clamp Function

By the purpose which protects external MOSFET, H level of OUT (5pin) is clamped to $V_{OUTH}(typ=12.5V)$. It prevents gate destruction of MOSFET by rising VCC (6pin) voltage. (It refers to Fig-23)
 OUT (5pin) is pull-down $R_{PDOUT}(typ=100k\Omega)$.

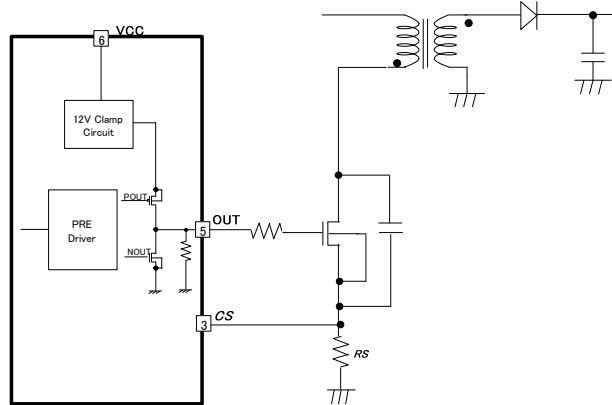

Fig-27 OUT (5pin) Construction

●Operation Mode of Protection Circuit

Operation mode of protection functions are shown in table3.

Table3 Operation Mode of Protection Circuit

| 項目 | Protection Mode | |
|------------------------------|--------------------------------------|--------------------------------------|
| | BM1Q001FJ | BM1Q002FJ |
| VCC Under Voltage Locked Out | Self-restart | Self-restart |
| VCC Over Voltage Protection | Self-restart (100us with timer) | Latch (100us with timer) |
| FB Over Load Protection | Self-restart(64ms delay, 512ms stop) | Self-restart(64ms delay, 512ms stop) |
| CS Open Protection | Self-restart | Self-restart |
| ZT Over Voltage Protection | None | Latch (100us with timer) |
| VCC Charge Protection | Self-restart | Self-restart |

● Power Dissipation

The thermal design should set operation for the following conditions.
 (Since the temperature shown below is the guaranteed temperature, be sure to take a margin into account.)

1. The ambient temperature T_a must be 85°C or less.
2. The IC's loss must be within the allowable dissipation P_d .

The thermal abatement characteristics are as follows.
 (PCB: 70 mm × 70 mm × 1.6 mm, mounted on glass epoxy substrate)

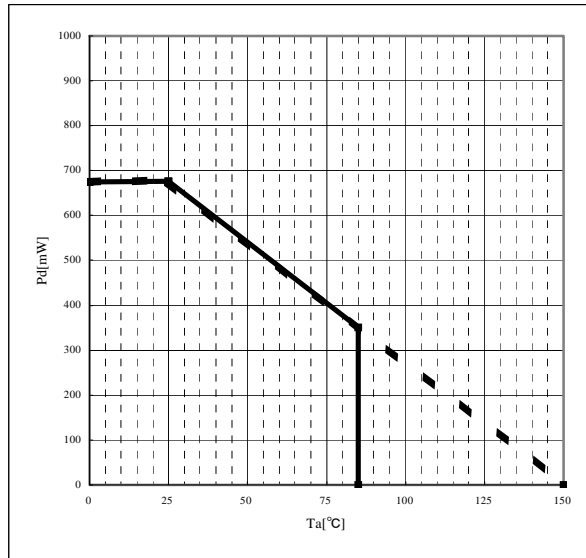

Fig-28 SOP-J8 Thermal Abatement Characteristics

●Operational Notes

(1) Absolute maximum ratings

Damage may occur if the absolute maximum ratings such as for applied voltage or operating temperature range are exceeded, and since the type of damage (short, open circuit, etc.) cannot be determined, in cases where a particular mode that may exceed the absolute maximum ratings is considered, use of a physical safety measure such as a fuse should be investigated.

(2) Power supply and ground lines

In the board pattern design, power supply and ground lines should be routed so as to achieve low impedance. If there are multiple power supply and ground lines, be careful with regard to interference caused by common impedance in the routing pattern. With regard to ground lines in particular, be careful regarding the separation of large current routes and small signal routes, including the external circuits. Also, with regard to all of the LSI's power supply pins, in addition to inserting capacitors between the power supply and ground pins, when using capacitors there can be problems such as capacitance losses at low temperature, so check thoroughly as to whether there are any problems with the characteristics of the capacitor to be used before determining constants.

(3) Ground potential

The ground pin's potential should be set to the minimum potential in relation to the operation mode.

(4) Pin shorting and attachment errors

When attaching ICs to the set board, be careful to avoid errors in the IC's orientation or position. If such attachment errors occur, the IC may become damaged. Also, damage may occur if foreign matter gets between pins, between a pin and a power supply line, or between ground lines.

(5) Operation in strong magnetic fields

Note with caution that these products may become damaged when used in a strong magnetic field.

(6) Input pins

In IC structures, parasitic elements are inevitably formed according to the relation to potential. When parasitic elements are active, they can interfere with circuit operations, can cause operation faults, and can even result in damage. Accordingly, be careful to avoid use methods that enable parasitic elements to become active, such as when a voltage that is lower than the ground voltage is applied to an input pin. Also, do not apply voltage to an input pin when there is no power supply voltage being applied to the IC. In fact, even if a power supply voltage is being applied, the voltage applied to each input pin should be either below the power supply voltage or within the guaranteed values in the electrical characteristics.

(7) External capacitors

When a ceramic capacitor is used as an external capacitor, consider possible reduction to below the nominal capacitance due to current bias and capacitance fluctuation due to temperature and the like before determining constants.

(8) Thermal design

The thermal design should fully consider allowable dissipation (Pd) under actual use conditions.

Also, use these products within ranges that do not put output Tr beyond the rated voltage and ASO.

(9) Rush current

In a CMOS IC, momentary rush current may flow if the internal logic is undefined when the power supply is turned ON, so caution is needed with regard to the power supply coupling capacitance, the width of power supply and GND pattern wires, and how they are laid out.

(10) Handling of test pins and unused pins

Test pins and unused pins should be handled so as not to cause problems in actual use conditions, according to the descriptions in the function manual, application notes, etc. Contact us regarding pins that are not described.

(11) Document contents

Documents such as application notes are design documents used when designing applications, and as such their contents are not guaranteed. Before finalizing an application, perform a thorough study and evaluation, including for external parts.

Status of this document

The Japanese version of this document is formal specification. A customer may use this translation version only for a reference to help reading the formal version.

If there are any differences in translation version of this document formal version takes priority

●Ordering Information

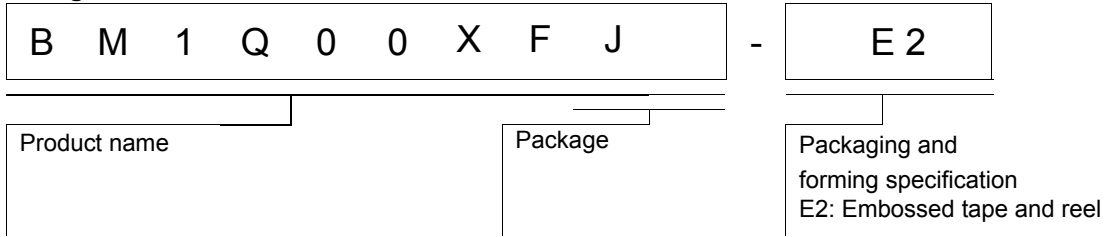

●Physical Dimension Tape and Reel Information

SOP-J8

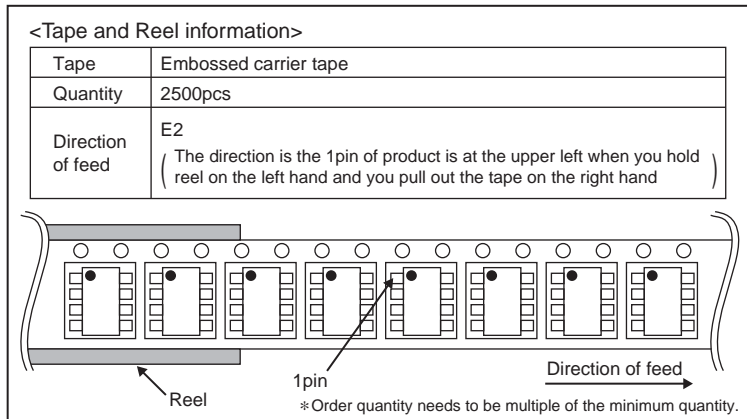
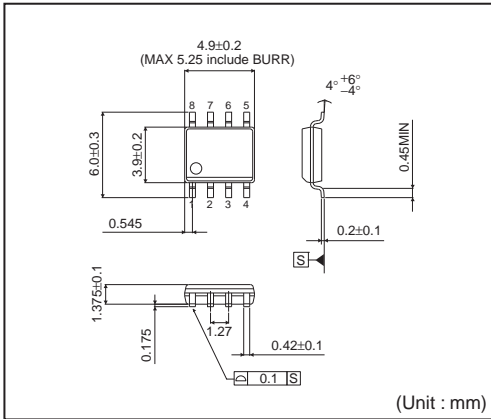

●Marking Diagram

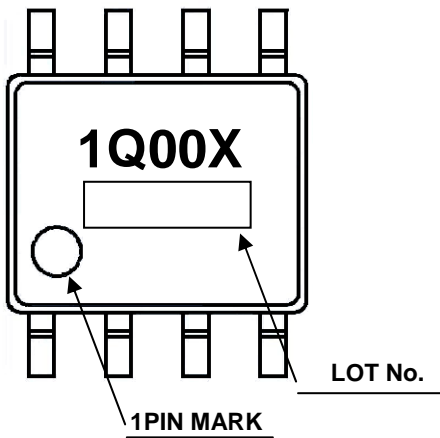

●Line Up

| |
|---------------------|
| Product (BM1Q00XFJ) |
| BM1Q001FJ |
| BM1Q002FJ |

●Revision History

| Date | Revision | Changes |
|------------|----------|--|
| 2013.04.05 | 001 | New Release |
| 2014.03.07 | 002 | Datasheet Format modified |
| 2014.03.07 | 002 | P-17 calculation change : Resonant time = $1 / (2 \times \pi \times (L_p \times C_{ds}))$ Add " $\sqrt{\quad}$ " |
| 2014.03.07 | 002 | P-17 Delete Figure-27 |
| 2014.03.07 | 002 | Change Operational Notes |
| 2015.06.17 | 003 | P-1,P-8,P-13 Modify transformer polarity in figure |

Notice

Precaution on using ROHM Products

- Our Products are designed and manufactured for application in ordinary electronic equipments (such as AV equipment, OA equipment, telecommunication equipment, home electronic appliances, amusement equipment, etc.). If you intend to use our Products in devices requiring extremely high reliability (such as medical equipment ^(Note 1), transport equipment, traffic equipment, aircraft/spacecraft, nuclear power controllers, fuel controllers, car equipment including car accessories, safety devices, etc.) and whose malfunction or failure may cause loss of human life, bodily injury or serious damage to property ("Specific Applications"), please consult with the ROHM sales representative in advance. Unless otherwise agreed in writing by ROHM in advance, ROHM shall not be in any way responsible or liable for any damages, expenses or losses incurred by you or third parties arising from the use of any ROHM's Products for Specific Applications.

(Note1) Medical Equipment Classification of the Specific Applications

| JAPAN | USA | EU | CHINA |
|-----------|-----------|------------|-----------|
| CLASS III | CLASS III | CLASS II b | CLASS III |
| CLASS IV | | CLASS III | |

- ROHM designs and manufactures its Products subject to strict quality control system. However, semiconductor products can fail or malfunction at a certain rate. Please be sure to implement, at your own responsibilities, adequate safety measures including but not limited to fail-safe design against the physical injury, damage to any property, which a failure or malfunction of our Products may cause. The following are examples of safety measures:
 - Installation of protection circuits or other protective devices to improve system safety
 - Installation of redundant circuits to reduce the impact of single or multiple circuit failure
- Our Products are designed and manufactured for use under standard conditions and not under any special or extraordinary environments or conditions, as exemplified below. Accordingly, ROHM shall not be in any way responsible or liable for any damages, expenses or losses arising from the use of any ROHM's Products under any special or extraordinary environments or conditions. If you intend to use our Products under any special or extraordinary environments or conditions (as exemplified below), your independent verification and confirmation of product performance, reliability, etc. prior to use, must be necessary:
 - Use of our Products in any types of liquid, including water, oils, chemicals, and organic solvents
 - Use of our Products outdoors or in places where the Products are exposed to direct sunlight or dust
 - Use of our Products in places where the Products are exposed to sea wind or corrosive gases, including Cl₂, H₂S, NH₃, SO₂, and NO₂
 - Use of our Products in places where the Products are exposed to static electricity or electromagnetic waves
 - Use of our Products in proximity to heat-producing components, plastic cords, or other flammable items
 - Sealing or coating our Products with resin or other coating materials
 - Use of our Products without cleaning residue of flux (even if you use no-clean type fluxes, cleaning residue of flux is recommended); or Washing our Products by using water or water-soluble cleaning agents for cleaning residue after soldering
 - Use of the Products in places subject to dew condensation
- The Products are not subject to radiation-proof design.
- Please verify and confirm characteristics of the final or mounted products in using the Products.
- In particular, if a transient load (a large amount of load applied in a short period of time, such as pulse. is applied, confirmation of performance characteristics after on-board mounting is strongly recommended. Avoid applying power exceeding normal rated power; exceeding the power rating under steady-state loading condition may negatively affect product performance and reliability.
- De-rate Power Dissipation (Pd) depending on Ambient temperature (Ta). When used in sealed area, confirm the actual ambient temperature.
- Confirm that operation temperature is within the specified range described in the product specification.
- ROHM shall not be in any way responsible or liable for failure induced under deviant condition from what is defined in this document.

Precaution for Mounting / Circuit board design

- When a highly active halogenous (chlorine, bromine, etc.) flux is used, the residue of flux may negatively affect product performance and reliability.
- In principle, the reflow soldering method must be used on a surface-mount products, the flow soldering method must be used on a through hole mount products. If the flow soldering method is preferred on a surface-mount products, please consult with the ROHM representative in advance.

For details, please refer to ROHM Mounting specification

Precautions Regarding Application Examples and External Circuits

1. If change is made to the constant of an external circuit, please allow a sufficient margin considering variations of the characteristics of the Products and external components, including transient characteristics, as well as static characteristics.
2. You agree that application notes, reference designs, and associated data and information contained in this document are presented only as guidance for Products use. Therefore, in case you use such information, you are solely responsible for it and you must exercise your own independent verification and judgment in the use of such information contained in this document. ROHM shall not be in any way responsible or liable for any damages, expenses or losses incurred by you or third parties arising from the use of such information.

Precaution for Electrostatic

This Product is electrostatic sensitive product, which may be damaged due to electrostatic discharge. Please take proper caution in your manufacturing process and storage so that voltage exceeding the Products maximum rating will not be applied to Products. Please take special care under dry condition (e.g. Grounding of human body / equipment / solder iron, isolation from charged objects, setting of Ionizer, friction prevention and temperature / humidity control).

Precaution for Storage / Transportation

1. Product performance and soldered connections may deteriorate if the Products are stored in the places where:
 - [a] the Products are exposed to sea winds or corrosive gases, including Cl₂, H₂S, NH₃, SO₂, and NO₂
 - [b] the temperature or humidity exceeds those recommended by ROHM
 - [c] the Products are exposed to direct sunshine or condensation
 - [d] the Products are exposed to high Electrostatic
2. Even under ROHM recommended storage condition, solderability of products out of recommended storage time period may be degraded. It is strongly recommended to confirm solderability before using Products of which storage time is exceeding the recommended storage time period.
3. Store / transport cartons in the correct direction, which is indicated on a carton with a symbol. Otherwise bent leads may occur due to excessive stress applied when dropping of a carton.
4. Use Products within the specified time after opening a humidity barrier bag. Baking is required before using Products of which storage time is exceeding the recommended storage time period.

Precaution for Product Label

QR code printed on ROHM Products label is for ROHM's internal use only.

Precaution for Disposition

When disposing Products please dispose them properly using an authorized industry waste company.

Precaution for Foreign Exchange and Foreign Trade act

Since concerned goods might be fallen under listed items of export control prescribed by Foreign exchange and Foreign trade act, please consult with ROHM in case of export.

Precaution Regarding Intellectual Property Rights

1. All information and data including but not limited to application example contained in this document is for reference only. ROHM does not warrant that foregoing information or data will not infringe any intellectual property rights or any other rights of any third party regarding such information or data.
2. ROHM shall not have any obligations where the claims, actions or demands arising from the combination of the Products with other articles such as components, circuits, systems or external equipment (including software).
3. No license, expressly or implied, is granted hereby under any intellectual property rights or other rights of ROHM or any third parties with respect to the Products or the information contained in this document. Provided, however, that ROHM will not assert its intellectual property rights or other rights against you or your customers to the extent necessary to manufacture or sell products containing the Products, subject to the terms and conditions herein.

Other Precaution

1. This document may not be reprinted or reproduced, in whole or in part, without prior written consent of ROHM.
2. The Products may not be disassembled, converted, modified, reproduced or otherwise changed without prior written consent of ROHM.
3. In no event shall you use in any way whatsoever the Products and the related technical information contained in the Products or this document for any military purposes, including but not limited to, the development of mass-destruction weapons.
4. The proper names of companies or products described in this document are trademarks or registered trademarks of ROHM, its affiliated companies or third parties.

General Precaution

1. Before you use our Products, you are requested to carefully read this document and fully understand its contents. ROHM shall not be in any way responsible or liable for failure, malfunction or accident arising from the use of any ROHM's Products against warning, caution or note contained in this document.
2. All information contained in this document is current as of the issuing date and subject to change without any prior notice. Before purchasing or using ROHM's Products, please confirm the latest information with a ROHM sales representative.
3. The information contained in this document is provided on an "as is" basis and ROHM does not warrant that all information contained in this document is accurate and/or error-free. ROHM shall not be in any way responsible or liable for any damages, expenses or losses incurred by you or third parties resulting from inaccuracy or errors of or concerning such information.



Компания «ЭлектроПласт» предлагает заключение долгосрочных отношений при поставках импортных электронных компонентов на взаимовыгодных условиях!

Наши преимущества:

- Оперативные поставки широкого спектра электронных компонентов отечественного и импортного производства напрямую от производителей и с крупнейших мировых складов;
- Поставка более 17-ти миллионов наименований электронных компонентов;
- Поставка сложных, дефицитных, либо снятых с производства позиций;
- Оперативные сроки поставки под заказ (от 5 рабочих дней);
- Экспресс доставка в любую точку России;
- Техническая поддержка проекта, помощь в подборе аналогов, поставка прототипов;
- Система менеджмента качества сертифицирована по Международному стандарту ISO 9001;
- Лицензия ФСБ на осуществление работ с использованием сведений, составляющих государственную тайну;
- Поставка специализированных компонентов (Xilinx, Altera, Analog Devices, Intersil, Interpoint, Microsemi, Aeroflex, Peregrine, Syfer, Eurofarad, Texas Instrument, Miteq, Cobham, E2V, MA-COM, Hittite, Mini-Circuits, General Dynamics и др.);

Помимо этого, одним из направлений компании «ЭлектроПласт» является направление «Источники питания». Мы предлагаем Вам помощь Конструкторского отдела:

- Подбор оптимального решения, техническое обоснование при выборе компонента;
- Подбор аналогов;
- Консультации по применению компонента;
- Поставка образцов и прототипов;
- Техническая поддержка проекта;
- Защита от снятия компонента с производства.



Как с нами связаться

Телефон: 8 (812) 309 58 32 (многоканальный)

Факс: 8 (812) 320-02-42

Электронная почта: org@eplast1.ru

Адрес: 198099, г. Санкт-Петербург, ул. Калинина, дом 2, корпус 4, литера А.