



Pushing Performance



People | Power | Partnership

HARTING Ha-VIS RFID System Components

HARTING Ha-VIS RFID System Components



Real-time information and the close synchronization of computer data and real processes play a critical role in process management and process optimization. Ensuring that information precisely maps and concurs with reality is the only way to control processes optimally and reap savings potentials accordingly.

One important prerequisite for guaranteeing that data and processes are synchronized is an intelligent infrastructure that makes data transparent and available throughout a company in order to achieve the maximum savings potentials.

RFID offers you the full potential to create intelligent infrastructures: benefit from the simultaneous identification of up to several hundred objects – without the need for the direct line of sight as required by barcode solutions. The collected data are immediately ready for further processing throughout the company.

Moreover, a transponder can be used to store information directly on the product at the same time it is identified. This means that these data are also always available wherever the product may happen to be located.

HARTING offers smart infrastructure solutions based on optimally coordinated components from a single source. These solutions enable the reliable control and steering of production and business processes, thereby resulting in lower costs.

The HARTING RFID Reader and components have been designed for harsh industrial applications. Deployed in the transportation, machinery and energy markets, HARTING RFID components guarantee secure and reliable information processing – also under the most challenging environmental conditions.



HARTING Smart Infrastructure Solutions

Real time information and the close synchronization of the virtual data world and the real process world play a crucial role in process management and process optimization. Information constitutes the basis of decisions.

Missing information is detrimental here, while information that is present in the company but that remains hidden due to incompatible and impermeable infrastructures is even more damaging as this costs money without being able to return the full benefits.



Material tracking Ha-VIS RFID SL 89 (MT)

- > 4-m range
- Functions when integrated into metal
- Low space requirements



Networking of the automation application Ha-VIS FTS 3100-A

- Ethernet Switch with Fast Track Switching technology
- Determinism with Standard Ethernet
- Preference given to automation data



Flexible use in the industrial environment Ha-VIS RF-R500 RFID reader

- Use in switch cabinet on DIN rail
- Installation directly on cross arms thanks to rugged aluminum housing
- Up to IP 64 with protection cap, otherwise IP 53



Rugged Ha-VIS RF-ANT-LR10 UHF RFID antenna with very short read range

- Protection class IP 67
- Optimized for near-field applications
- Identification of tools in machines or ensuring the correct positioning of objects, for example



Tool management / maintenance Ha-VIS RFID VT 89 (HT)

- > 2,5 m range on metal in connection with highly compact footprint
- Variable installation possibilities
- Especially resistant to heat, chemicals, such as during autoclaving



Ha-VIS RFID CS/CF 89 (NT)

- Also readable in damp environments
- Rugged housing
- EPC C1 Gen2 compatibility
- Protection class IP 69K
- Expanded memory



**RFID out of the Box-Lösung
Complete RFID system**

- incl. RFID reader, switch, protection against overvoltage, and power supply
- Protection class IP65
- Customer specific configurations possible
- Robust housing



Measuring device administration for calibration

- >4m range
- Function in metal guaranteed
- Compact space requirements



Finished part monitoring in building management

Monitoring of static characteristics in prefabricated building parts using RFID technology



**Automatic process mapping using RFID reader
Ha-VIS RF-R500**

- Read range to 16 m
- 4 antennas can be connected
- Up to IP 64 with protection cap



Localization of transport means for automatic booking processes

Ha-VIS RFID CT 89 (NT)

- >4,5 m range
- Function in and on precast concrete units
- Development for the construction trade



Incoming goods inspection via RFID gate

Extremely rugged outdoor antenna for Ha-VIS RF-ANT-WR80-30 for gate applications

- Ruggedized housing
- 30°/70° aperture angle
- Protection class IP 65



Maintenance management

Cyclic maintenance of safety-related equipment is automated with modern RFID transponders



Container management

Selective identification of containers with Ha-VIS RFID antennas, especially in harsh industrial environments. Ha-VIS RF-ANT-WR30

- High read range
- Flat, compact design
- Protection class IP 65

RFID Products & Accessories

Ha-VIS UHF long range RFID Reader RF-R500

Features

- Suitable for harsh industrial environments
- Very high read range of up to 16 m
- Power over Ethernet capability (PoE) (RF-R500-p)
- 4 antennas can be connected
- Up to 4 W transmitter power (RF-R500-p), otherwise 2 W (RF-R500-c)
- Up to IP 64 with protection cap (optional)
- Interfaces (Ethernet, USB, RS 232, RS 485)
- Fast readout of >150 transponders
- 860 - 960 MHz
- Profibus / Profinet: optional via gateway
- PLC connection – templates of function blocks on request
- Web interface

Identification	Part. no.
RF-R500-c-EU	20 91 104 1103
RF-R500-c-US	20 91 104 1104
RF-R500-p-EU	20 91 104 1101
RF-R500-p-US	20 91 104 1102



Ha-VIS UHF mid range Reader RF-R200

Features

- External antenna (max. read range up to 2m)
- Internal antenna (max. read range up to 30cm)
- 500mW transmission power
- Power over Ethernet
- SMA connector
- Automatic reporting of tags (notification mode)

Identification	Part. no.
Ha-VIS RF-R200 (expected availability 2nd Q. 2013)	20 91 106 1101

Accessories

DIN rail mounting kit RF-R200	20 93 102 0202
Mounting Kit RF-R200	20 93 102 0203
Desktop power supply for RF-R200 (EU)	20 93 310 0203



Ha-VIS RFID Box

Features

- Completely installed RFID system in cabinet
- Tested and ready for connection
- Modular system
- Customer specific configurations possible
- 2 mm VA steel
- Railway norms
- Protection class IP65

Identification	Part. no.
Ha-VIS RFID Box (RF-R500-p-EU, eCon 2050-A)	20 91 421 1001
Ha-VIS RFID Box (RF-R500-c-EU, eCon 2050-A)	20 91 411 1001

(both variants expected availability Q1 / 2013)



Ha-VIS UHF mobile Reader RF-M3000

Features

- Read range up to 2 m
- IP 65 protection
- Several drops on concrete from 1.8 m (handheld switched on incl. WiFi, Barcode scanner, imager)
- WiFi
- 1 GB Flash
- 3.6" TFT Display

Identification

Identification	Part. no.
RFID Handheld RF-M3000	20 91 211 1011
RFID Handheld RF-M3001 1D Laser Scanner	20 91 211 1111
RFID Handheld RF-M3002 2D Imager	20 91 211 1311

Mobile reading devices with higher read ranges on request

Accessories

Ha-VIS RF-M3000 battery 4400 mAh	20 93 405 0101
Ha-VIS RF-M3000 Stylus 5 Pack (spare pen for touch screen)	20 93 405 0102
Power Supply AC universal 5 V / 3 A	20 93 405 0103
RF-M3000 Docking Station Desktop	20 93 305 0101
RF-M3000 Docking Station Quad (4-fold incl. RJ45)	20 93 305 0102
RF-M3000 Cradle Vehicle Powered 12 V	20 93 305 0103
RF-M3000 Ram mounting system	20 93 305 0104
RF-M3000 Plastic pistol grip	20 93 705 0101
RF-M3000 Soft holster kit	20 93 705 0102



DIN Rail mounting kit

Features

- Board inc. screws for installing the Ha-VIS RF-R500 on DIN rail

Identification

Identification	Part. no.
DIN rail mounting kit	20 93 102 0201



Ha-VIS RFID reader protection cap

Features

- Increased protection class IP 64
- Up to 8 PG lead-throughs
- Simple and reliable installation on Ha-VIS RF-R500

Identification

Identification	Part. no.
Ha-VIS Protection cap RF-R500	20 93 901 0101



Ha-VIS RFID UHF wide range antenna

Features

- Compact design
- High read range
- Suitable for industrial environment
- Optimized for portal applications
- 69° aperture angle
- Antenna gain 8.5 dBic
- High IP 65 protection
- Suitable for outside areas
- TNC socket
- 865 - 870 MHz (EU) or 902 - 928 MHz (US)



Identification

Part. no.

RF-ANT-WR30-EU	20 93 201 0102
RF-ANT-WR30-US	20 93 201 0103

Ha-VIS RFID UHF ruggedized wide range antenna, 30° aperture angle

Features

- Different aperture angles for azimuth and elevation planes (30° / 70°)
- Ruggedized housing
- Compact design
- High read range
- Antenna gain 11 dBic
- Suitable for industrial environment
- Optimized for portal applications
- High IP 65 protection
- Suitable for outside areas
- N socket
- 865 - 870 MHz (EU) or 902 - 928 MHz (US)



Identification

Part. no.

RF-ANT-WR80-30-EU	20 93 201 0203
RF-ANT-WR80-30-US	20 93 201 0204

Ha-VIS RFID UHF mid range antenna

Features

- Very compact design
- Medium read range (0.2 m - 2 m)
- Suitable for industrial environment with near- and far-field applications
- 100° aperture angle
- Antenna gain 4 dBic
- High IP 67 protection
- Suitable for outside areas
- TNC socket
- 865 - 870 MHz (EU) or 902 - 928 MHz (US)

Identification

Identification	Part. no.
RF-ANT-MR20-EU	20 93 201 0301
RF-ANT-MR20-US	20 93 201 0302



Ha-VIS RFID UHF short mid range antenna

Features

- Very compact design
- Medium read range (0.2 m - 1 m)
- Worldwide applicable (860 - 930 MHz)
- 100° aperture angle
- High IP 67 protection
- Max. input power 1 W
- Ideally suitable for metallic environments because of -12 dBic@866 MHz
- TNC socket

Identification

Identification	Part. no.
RF-ANT-sMR20 (expected availability Q2 / 2013)	20 93 201 0304



Ha-VIS RFID UHF ultra-low range antenna

Features

- Minimal size
- Extremely high spatial selectivity
- Suitable for industrial environment
- Optimized for near-field applications (< 5 cm)
- High IP 67 protection
- Suitable for outside areas
- TNC socket
- worldwide applicable (860-930 MHz)

Identification

Identification	Part. no.
RF-ANT-LR10	20 93 201 0303



Ha-VIS RFID wall/mast antenna mounting kit

Features

- Very rugged
- Can be aligned in two directions
- Wide adjustment angle



Identification

RF-MOUNT-ANT-A (for RF-ANT-WR30)

Part. no.

20 93 102 0103

Ha-VIS RFID mast antenna mounting kit

Features

- Diameter of post 25 - 76 mm
- Turnable by two links
- Precision of angle adjustment 2°
- Max. weight to carry 20 kg

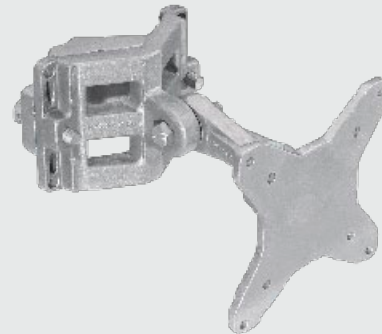

Identification

RF-MOUNT-ANT-C (for RF-ANT-WR30)

Part. no.

20 93 102 0105

Ha-VIS RFID mast mounting

Features

- Very rugged
- Can be tipped
- Stainless steel
- Necessary pipe (diameter 50 - 115 mm) not included



Identification

RF-Mount-ANT-B (for RF-ANT-WR80-30)

Part. no.

20 93 102 0104

Ha-VIS RFID standard antenna cable

Features

- 3 m standard cable
- TNC - SMA
- Attenuation 68 dB/100 m (@800 MHz)



Identification

Ha-VIS Coax SMA-TNC, RG58, 3 m

Part. no.

20 93 204 0101

Ha-VIS RFID low loss antenna cable

Features

- 3 m and 10 m low loss cable
- Attenuation 28 dB / 100 m (@800 MHz)
- Outer diameter 5.4 mm
- Left side: SMA connector
- Right side: TNC or N connector



Identification

Ha-VIS Coax SMA-TNC, LL 240 flex, 3 m

Ha-VIS Coax SMA-TNC, LL 240 flex, 10 m

Ha-VIS Coax SMA-N, LL 240 flex, 3 m

Ha-VIS Coax SMA-N, LL 240 flex, 10 m

Part. no.

20 93 204 0102

20 93 204 0103

20 93 204 0104

20 93 204 0105

Ha-VIS RFID heavy duty low loss antenna cable

Features

- 3 m and 10 m low loss cable
- Suitable for harsh environments
- Attenuation 22 dB / 100 m (@800 MHz)
- Outer diameter 10.3 mm
- TNC - N



Identification

Ha-VIS Coax TNC-N, RG 213, 3 m

Ha-VIS Coax TNC-N, RG 213, 10 m

Part. no.

20 93 204 0106

20 93 204 0107

Ha-VIS RFID SMA TNC antenna cable adapter

Features

- Adaptor for connecting RG213 cable to reader



Identification	Part. no.
Adapter TNC-SMA	20 93 204 0301

Ha-VIS RFID PT 86 (HT)

Features

- Functions on metal
- Rugged, chemical resistant housing
- EPC C1 Gen2 compatibility
- Protection class IP 69K
- Expanded memory

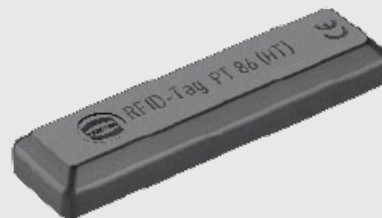

Identification	Part. no.
Ha-VIS RFID PT 86 (HT) 10 units	20 92 641 0101
Ha-VIS RFID PT 86 (HT) 50 units	20 92 641 0102

Ha-VIS RFID VT 86 (HT)

Features

- Functions on metal
- Rugged, chemical resistant housing
- EPC C1 Gen2 compatibility
- Protection class IP 69K
- Expanded memory
- Flexible mounting



Identification	Part. no.
Ha-VIS RFID VT 86 (HT) 10 units	20 92 641 0201
Ha-VIS RFID VT 86 (HT) 50 units	20 92 641 0202
Ha-VIS RFID VT868 (HT) 0.43k (EU, 0,43 kByte memory) (expected availability Q2 / 2013)	on request
Ha-VIS RFID VT92 (HT) 0.43k (US, Asia, 0.43 kByte memory) (expected availability Q2 / 2013)	on request

Ha-VIS SL89 Set

Features

- Extremely high level of mechanical protection
- Protection class IP 69K
- EPC C1 Gen2 compatibility
- Expanded memory
- Customer specific shapes of metal pieces for individual customer requests

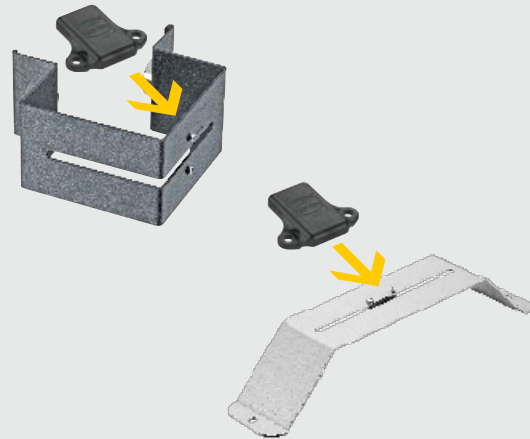

Identification

Ha-VIS SL89 Set

Part. no.

On definition of metal piece

Ha-VIS RFID CT/CF/CS 89 (NT) product family

Features

- Can also be read in damp environments
- Rugged housing
- EPC C1 Gen2 compatibility
- Protection class IP 69K
- Expanded memory



Identification

Ha-VIS RFID CT89 (NT) 10 units
 Ha-VIS RFID CT89 (NT) 50 units
 Ha-VIS RFID CF89 (NT) 10 units
 Ha-VIS RFID CF89 (NT) 50 units
 Ha-VIS RFID CS89 (NT) 10 units
 Ha-VIS RFID CS89 (NT) 50 units

Part. no.

20 92 641 0301
 20 92 641 0302
 20 92 641 0401
 20 92 641 0402
 20 92 641 0501
 20 92 641 0502

Ha-VIS RFID Transponder FT 89

Features

- For non-conductive surfaces
- Extremely mechanical robust
- Barcode and company logo possible
- Flexible mounting on different surfaces
- Adhesive mounting



Identification

Ha-VIS RFID FT 89 passiv Tr. 50 units
 Ha-VIS RFID FT 89 passiv Tr. 500 units

Part. no.

20 92 641 0702
 20 92 641 0703

Ha-VIS Middleware

Features

- The bridge between RFID readers and company software
- Easy integration of HARTING RFID Reader
- Filtering, grouping and aggregation based on various tag information
- Application flow triggered by manual, digital IO or scheduled events
- Report of cumulated data in standardized or customized formats
- Central RFID Reader management
- Advanced reading, writing, locking and muting of RFID transponders
- Conform to EPCglobal® ALE 1.1 standard

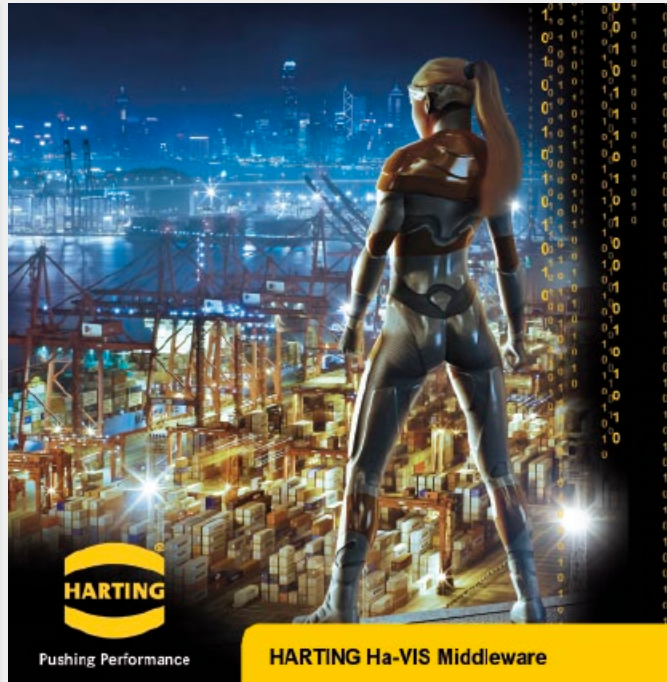

Identification	Part. no.
Ha-VIS Middleware Incl. XML Subscriber and Connector for one Ha-VIS RF-R500 RFID Reader	20 16 210 1110
Subscriber (software side) Easy API	20 16 220 3110
MySQL Subscriber	20 16 220 4110
Connector (hardware side) Connector for up to 5 RF-R500	20 16 230 1120
Connector for up to 15 RF-R500	20 16 230 1130
Connector for up to 25 RF-R500	20 16 230 1140
Connector for up to 50 RF-R500	20 16 230 1150

Ha-VIS Dashboard

Features

- Centralised management of managed Ethernet devices
- Network monitoring
- Event- and Alarm-Management
- Performance Monitoring
- Administration of complex RFID Reader-Installations

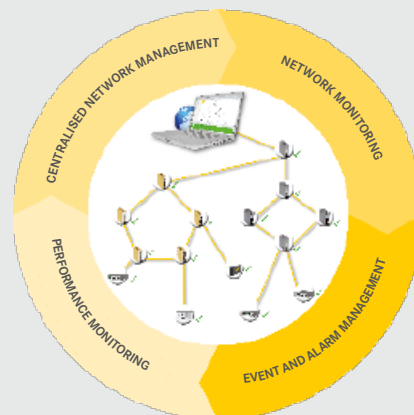

Identification	Part. no.
Ha-VIS Dashboard License 64	20 16 111 2110
Ha-VIS Dashboard License 128	20 16 111 3110
Ha-VIS Dashboard License 256	20 16 111 4110

ICPN Service

- RFID Proof-of-Concept at the site of customer or in the RFID laboratory
- Configuration service for Ha-VIS RFID Reader and Middleware
- Commissioning at site of customer
- Consulting for RFID systems
- Trainings
- Telephone hotline
- Email support

AE – United Arab Emirates

HARTING Middle East FZ-LLC
Knowledge Village
Block 2A, Office F72
Dubai, United Arab Emirates
E-Mail: uae@HARTING.com, www.HARTING.ae

AT – Austria

HARTING Ges. m. b. H.
Deutschstraße 19, A-1230 Wien
E-Mail: at@HARTING.com, www.HARTING.at

AU – Australia

HARTING Pty Ltd
Suite 11 / 2 Enterprise Drive
Bundoora 3083, AUS-Victoria
E-Mail: au@HARTING.com, www.HARTING.com.au

BE – Belgium

HARTING N.V./S.A.
Z.3 Doornveld 23, B-1731 Zellik
E-Mail: be@HARTING.com, www.HARTING.be

BR – Brazil

HARTING Ltda.
Rua Major Paladino 128 – Prédio 11
CEP 05307-000 – São Paulo – SP – Brasil
E-Mail: br@HARTING.com, www.HARTING.com.br

CA – Canada

HARTING Canada Inc.
8455 Trans-Canada Hwy., Suite 202
St. Laurent, OC, H4S1Z1, Canada
E-Mail: info.ca@HARTING.com, www.HARTING.ca

CH – Switzerland

HARTING AG
Industriestrasse 26, CH-8604 Volketswil
E-Mail: ch@HARTING.com, www.HARTING.ch

CH – Switzerland

HARTING AG Mitronics
Leugenestrasse 10, CH-2500 Biel 6
E-Mail: mit@HARTING.com
www.HARTING-mitronics.ch

CN – China

Zhuhai HARTING Ltd.
Shanghai Branch, Room 5403
300 Huai Hai Road (M.), Luwan District
Shanghai 200021, China
E-Mail: cn@HARTING.com, www.HARTING.com.cn

CZ – Czech Republic

HARTING s.r.o.
Mlýnská 2, CZ-160 00 Praha 6
E-Mail: cz@HARTING.com, www.HARTING.cz

DE – Germany

HARTING Deutschland GmbH & Co. KG
P.O. Box 2451, D-32381 Minden
Simeonscarré 1, D-32427 Minden
E-Mail: de@HARTING.com,
www.HARTING.de

DK – Denmark

HARTING ApS
Hjulmagervej 4a, DK – 7100 Vejle
E-Mail: dk@HARTING.com, www.HARTING.com

EE – Eastern Europe

HARTING Eastern Europe GmbH
Bamberger Straße 7, D-01187 Dresden
E-Mail: Eastern.Europe@HARTING.com
www.HARTING.com

ES – Spain

HARTING Iberia S.A.
Avda. Josep Tarradellas 20-30 4o 6a,
E-08029 Barcelona
E-Mail: es@HARTING.com, www.HARTING.es

FI – Finland

HARTING Oy
Teknobulevardi 3-5, FI-01530 Vantaa
E-Mail: fi@HARTING.com, www.HARTING.fi

FR – France

HARTING France
181 avenue des Nations, Paris Nord 2
BP 66058 Tremblay en France
F-95972 Roissy Charles de Gaulle Cédex
E-Mail: fr@HARTING.com, www.HARTING.fr

GB – Great Britain

HARTING Ltd.
Caswell Road, Brackmills Industrial Estate
GB-Northampton, NN4 7PW
E-Mail: gb@HARTING.com, www.HARTING.co.uk

HK – Hong Kong

HARTING (HK) Limited
Regional Office Asia Pacific
3512 Metroplaza Tower 1, 233 Hing Fong Road
Kwai Fong, N. T., Hong Kong
E-Mail: ap@HARTING.com, www.HARTING.com.hk

HU – Hungary

HARTING Magyarország Kft.
Fehérvári út 89-95, H-1119 Budapest
E-Mail: hu@HARTING.com, www.HARTING.hu

IN – India

HARTING India Private Limited
No. D, 4th Floor, 'Doshi Towers'
No. 156 Poonamallee High Road,
Kilpauk, Chennai 600 010, Tamil Nadu, India
E-Mail: in@HARTING.com, www.HARTING.co.in

IT – Italy

HARTING SpA
Via dell'Industria 7, I-20090 Vimodrone (Milano)
E-Mail: it@HARTING.com, www.HARTING.it

JP – Japan

HARTING K. K.
Yusen Shin-Yokohama 1 Chome Bldg., 2F
1-7-9, Shin-Yokohama, Kohoku
Yokohama 222-0033 Japan
E-Mail: jp@HARTING.com, www.HARTING.co.jp

KR – Korea

HARTING Korea Limited
#308 Yatap Leaders Building, 342-1 Yatap-dong
Bundang-gu, Sungnam-City, Kyunggi-do
463-828 Republic of Korea
E-Mail: kr@HARTING.com, www.HARTING.co.kr

MY – Malaysia (Office)

HARTING Singapore Pte Ltd
Malaysia Branch, 11-02 Menara Amcorp,
Jln. Persiaran Barat, 46200 PJ, Sel. D. E., Malaysia
E-Mail: sg@HARTING.com, www.HARTING.com

NL – Netherlands

HARTING B.V.
Larenweg 44, NL-5234 KA 's-Hertogenbosch
Postbus 3526, NL-5203 DM 's-Hertogenbosch
E-Mail: nl@HARTING.com, www.HARTINGbv.nl

NO – Norway

HARTING A/S
Øststensjøveien 36, N-0667 Oslo
E-Mail: no@HARTING.com, www.HARTING.no

PL – Poland

HARTING Polska Sp. z o.o.
ul. Duńska 9, PL-54-427 Wrocław
E-Mail: pl@HARTING.com, www.HARTING.pl

PT – Portugal

HARTING Iberia, S. A.
Avda. Josep Tarradellas, 20-30, 4o 6a, E-08029 Barcelona
E-Mail: es@HARTING.com, www.HARTING.es/pt

RO – Romania

HARTING Romania SCS
Europa Unita str. 21, 550018-Sibiu, Romania
E-Mail: ro@HARTING.com, www.HARTING.com

RU – Russia

HARTING ZAO
Maily Sampsoniyevsky prospect 2A
194044 Saint Petersburg, Russia
E-Mail: ru@HARTING.com, www.HARTING.ru

SE – Sweden

HARTING AB
Gustavslundsvägen 141 B 4tr, S-167 51 Bromma
E-Mail: se@HARTING.com, www.HARTING.se

SG – Singapore

HARTING Singapore Pte Ltd.
25 International Business Park
#04-108 German Centre, Singapore 609916
E-Mail: sg@HARTING.com, www.HARTING.sg

SK – Slovakia

HARTING s.r.o.
Sales office Slovakia
J. Simora 5, SK – 940 67 Nové Zámky
E-Mail: sk@HARTING.com, www.HARTING.sk

TR – Turkey

HARTING TURKEI Elektronik Ltd. Şti.
Barbaros Mah. Dereboyu Cad. Fesleğen Sok.
Uphill Towers, A-1b Kat:8 D:45
34746 Ataşehir, İstanbul
E-Mail: tr@HARTING.com, www.HARTING.com.tr

TW – Taiwan

HARTING Taiwan Limited
Room 1, 5/F, 495 GuangFu South Road
RC-110 Taipei, Taiwan
E-Mail: tw@HARTING.com, www.HARTING.com.tw

US – USA

HARTING Inc. of North America
1370 Bowes Road, USA-Elgin, Illinois 60123
E-Mail: us@HARTING.com, www.HARTING-USA.com



Pushing Performance

HARTING Technology Group

Marienwerderstraße 3, 32339 Espelkamp – Germany

P.O. Box 11 33, 32325 Espelkamp – Germany

Phone +49 5772 47-0, Fax +49 5772 47-400

RFID@HARTING.com

www.HARTING-RFID.com



Компания «ЭлектроПласт» предлагает заключение долгосрочных отношений при поставках импортных электронных компонентов на взаимовыгодных условиях!

Наши преимущества:

- Оперативные поставки широкого спектра электронных компонентов отечественного и импортного производства напрямую от производителей и с крупнейших мировых складов;
- Поставка более 17-ти миллионов наименований электронных компонентов;
- Поставка сложных, дефицитных, либо снятых с производства позиций;
- Оперативные сроки поставки под заказ (от 5 рабочих дней);
- Экспресс доставка в любую точку России;
- Техническая поддержка проекта, помощь в подборе аналогов, поставка прототипов;
- Система менеджмента качества сертифицирована по Международному стандарту ISO 9001;
- Лицензия ФСБ на осуществление работ с использованием сведений, составляющих государственную тайну;
- Поставка специализированных компонентов (Xilinx, Altera, Analog Devices, Intersil, Interpoint, Microsemi, Aeroflex, Peregrine, Syfer, Eurofarad, Texas Instrument, Miteq, Cobham, E2V, MA-COM, Hittite, Mini-Circuits, General Dynamics и др.);

Помимо этого, одним из направлений компании «ЭлектроПласт» является направление «Источники питания». Мы предлагаем Вам помощь Конструкторского отдела:

- Подбор оптимального решения, техническое обоснование при выборе компонента;
- Подбор аналогов;
- Консультации по применению компонента;
- Поставка образцов и прототипов;
- Техническая поддержка проекта;
- Защита от снятия компонента с производства.



Как с нами связаться

Телефон: 8 (812) 309 58 32 (многоканальный)

Факс: 8 (812) 320-02-42

Электронная почта: org@eplast1.ru

Адрес: 198099, г. Санкт-Петербург, ул. Калинина, дом 2, корпус 4, литера А.