



Heyco® Push Latches

- Panels easily open when gently pushed in.
- Easy installation – snaps into hole in panel.
- Enables a single latch to accommodate multiple panel thicknesses.

MOUNTING HOLE Dimensions		PANEL THICKNESS		PART NO.		DESCRIPTION	Mating Pin	PIN DEPTH				PART DIMENSIONS					
in.	mm.	in.	mm.	Black				X Push-in		Y Closed		A Length		B Arm Spread		C Head Height	
.315 x .276	8,0 X 7,0	.08	2,0	14309		DPL-100A	1	.071	1,80	.014	0,35	.59	15,0	.43	11,0	.11	2,9
				14312		DPL-150F	2	.077	1,95	.020	0,50	.58	14,8	.43	11,0	.11	2,9
				14313		DPL-700F	2	.073	1,85	.020	0,50	.58	14,8	.43	11,0	.11	2,9
				14314		DPL-400P	3	.059	1,50	.016	0,40	.58	14,8	.43	11,0	.12	3,1

Standard color black

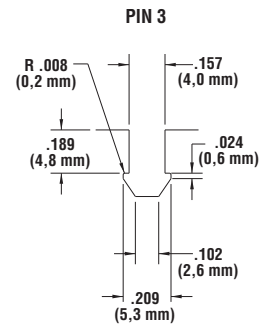
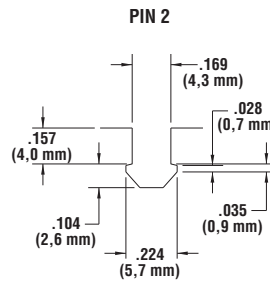
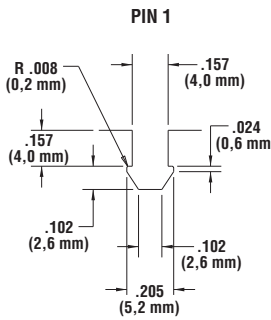
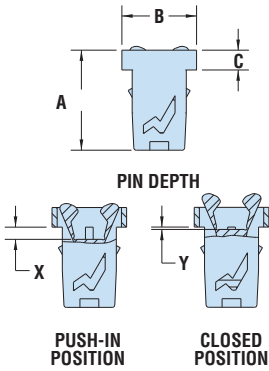

Heyco® Snap Latch Rivets



Grommet

- Designed for fast and easy installation and removal - simply push to fasten and pull to release.
- Ideal for frequent maintenance work.
- Typical applications include metal enclosures, telecom equipment, appliances and electrical equipment.

FIXED PANEL HOLE DIAMETER	REMOVABLE PANEL THICKNESS	PART NO.		DESCRIPTION	MATING PLUNGER		PART DIMENSIONS									
		Black	White		Black	White	A Body Length		B Head Diameter		C Head Height					
.253	6,4	.043	1,1	12283	12284	HSLG-1M	12261	12262	.31	8,0						
		.063	1,6	12285	12286	HSLG-2M	12263	12264	.33	8,5	.33	8,5	.07	1,8		
		.098	2,5	12287	12288	HSLG-3M	12265	12266	.37	9,5						
		.161	4,1	12289	12290	HSLG-4M	12267	12268	.43	11,0						

Standard colors black and white.

Plunger

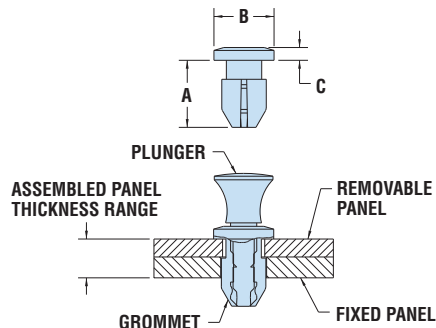

REMOVABLE PANEL HOLE DIAMETER	ASSEMBLED PANEL THICKNESS RANGE	PART NO.		DESCRIPTION	MATING GROMMET					
		Black	White		Black	White				
.237	6,0	.059	1,5	.146	3,7	12261	12262	HSLPB-1M	12283	12284
		.079	2,0	.165	4,2	12263	12264	HSLPB-2M	12285	12286
		.118	3,0	.205	5,2	12265	12266	HSLPB-3M	12287	12288
		.181	4,6	.272	6,9	12267	12268	HSLPB-4M	12289	12290

Standard colors black and white.

Quick Specs

Material	Nylon 6/6
Flammability Rating	94V-2
Temperature Range	32°F (0°C) to 185°F (85°C)

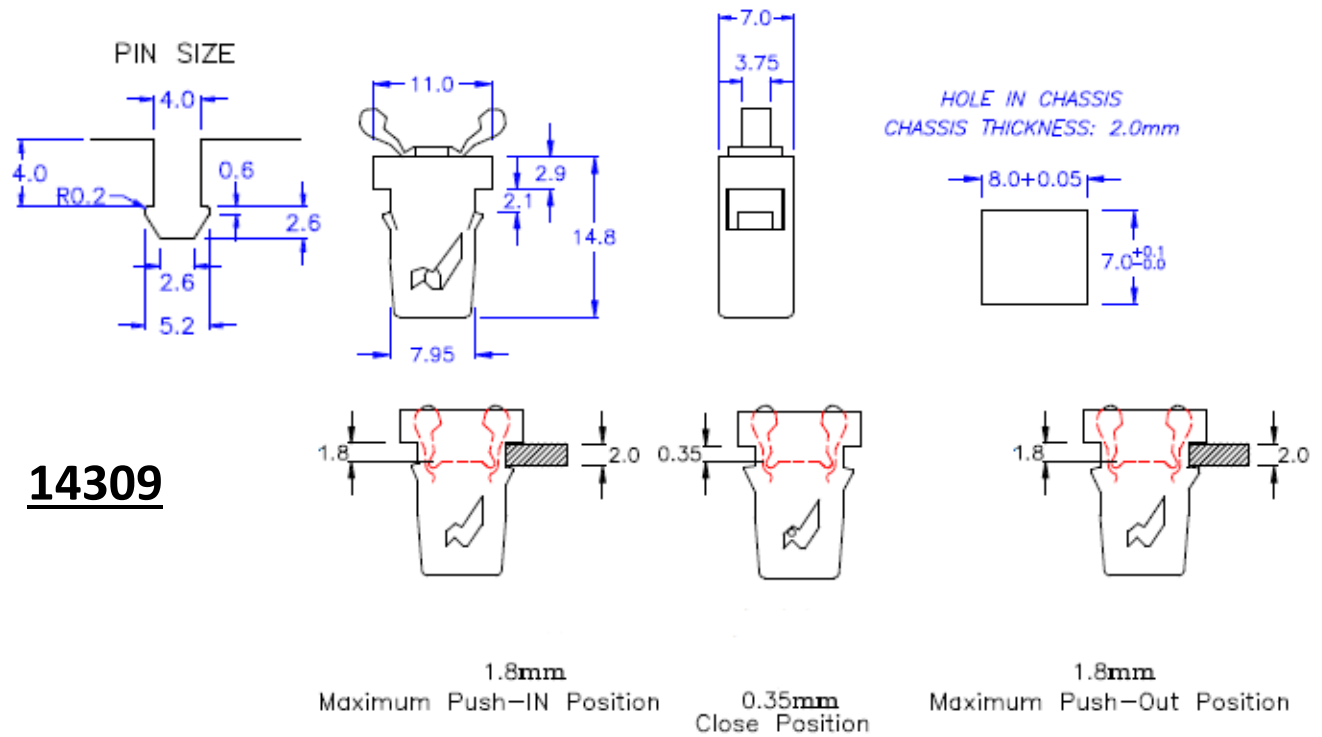

- A- Door latch is opened by pushing-in 1.45mm distance (which is the 1.8mm distance from the bottom of matching clip to the top surface of platform)
- B- The distance between bottom of matching clip to the top surface of platform should be in 0.35mm in closed position

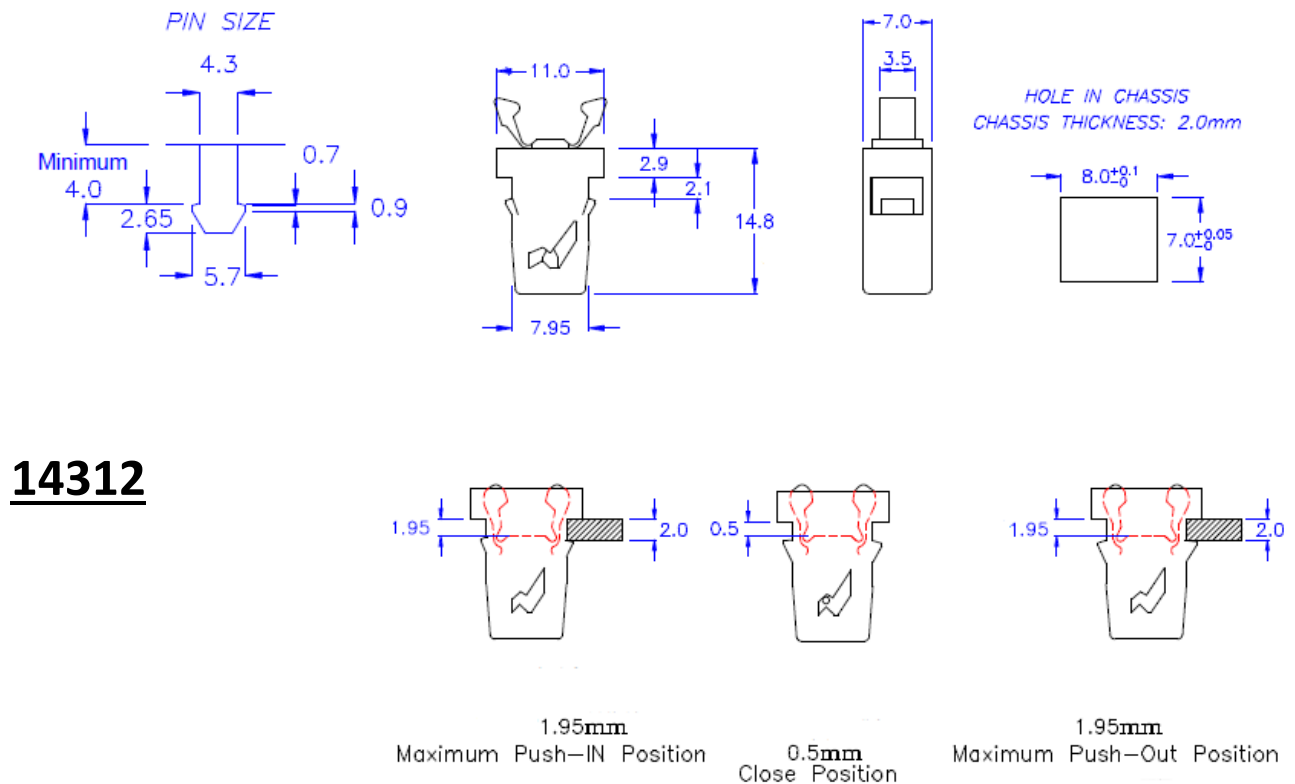

- A- Door latch is opened by pushing-in 1.45mm distance (which is the 1.8mm distance from the bottom of matching clip to the top surface of platform)
- B- The distance between bottom of matching clip to the top surface of platform should be in 0.5mm in closed position

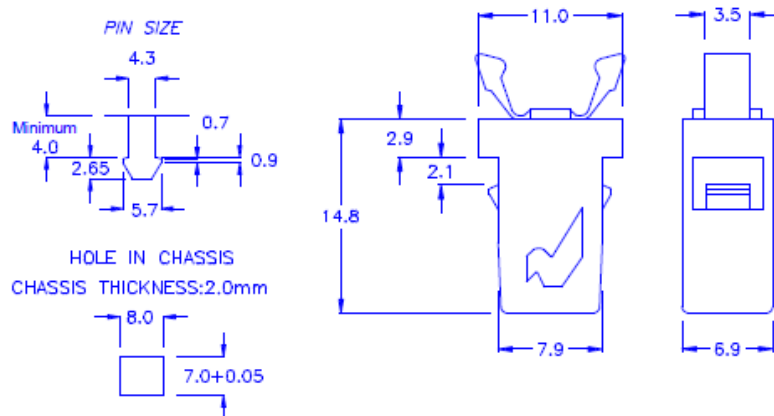

14313

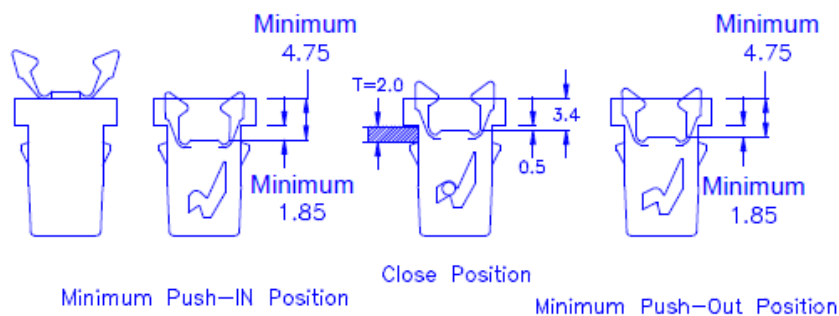

A- Door latch is opened by pushing-in 1.35mm distance (which is the 1.8mm distance from the bottom of matching clip to the top surface of platform)

B- The distance between bottom of matching clip to the top surface of platform should be in 0.5mm in closed position

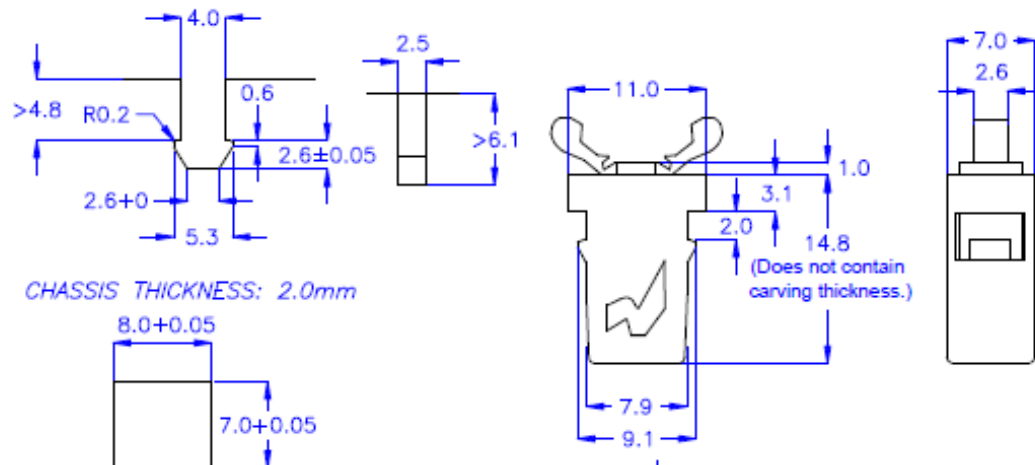

14314

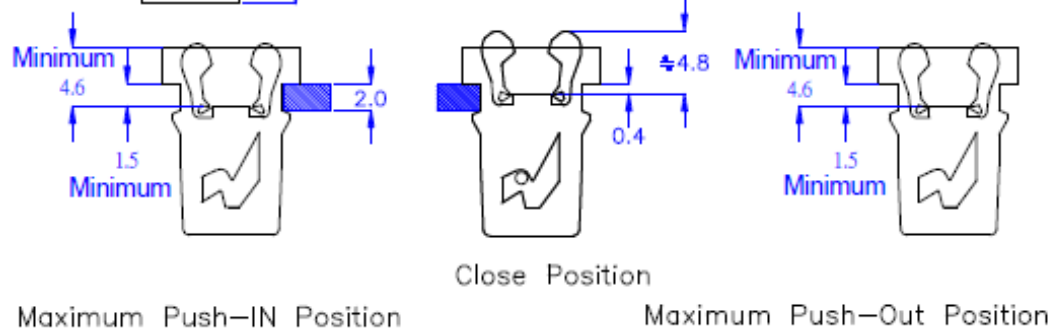

A- Door latch is opened by pushing-in 1.1mm distance (which is the 1.8mm distance from the bottom of matching clip to the top surface of platform)

B- The distance between bottom of matching clip to the top surface of platform should be in 0.4mm in closed position



Компания «ЭлектроПласт» предлагает заключение долгосрочных отношений при поставках импортных электронных компонентов на взаимовыгодных условиях!

Наши преимущества:

- Оперативные поставки широкого спектра электронных компонентов отечественного и импортного производства напрямую от производителей и с крупнейших мировых складов;
- Поставка более 17-ти миллионов наименований электронных компонентов;
- Поставка сложных, дефицитных, либо снятых с производства позиций;
- Оперативные сроки поставки под заказ (от 5 рабочих дней);
- Экспресс доставка в любую точку России;
- Техническая поддержка проекта, помощь в подборе аналогов, поставка прототипов;
- Система менеджмента качества сертифицирована по Международному стандарту ISO 9001;
- Лицензия ФСБ на осуществление работ с использованием сведений, составляющих государственную тайну;
- Поставка специализированных компонентов (Xilinx, Altera, Analog Devices, Intersil, Interpoint, Microsemi, Aeroflex, Peregrine, Syfer, Eurofarad, Texas Instrument, Miteq, Cobham, E2V, MA-COM, Hittite, Mini-Circuits, General Dynamics и др.);

Помимо этого, одним из направлений компании «ЭлектроПласт» является направление «Источники питания». Мы предлагаем Вам помощь Конструкторского отдела:

- Подбор оптимального решения, техническое обоснование при выборе компонента;
- Подбор аналогов;
- Консультации по применению компонента;
- Поставка образцов и прототипов;
- Техническая поддержка проекта;
- Защита от снятия компонента с производства.



Как с нами связаться

Телефон: 8 (812) 309 58 32 (многоканальный)

Факс: 8 (812) 320-02-42

Электронная почта: org@eplast1.ru

Адрес: 198099, г. Санкт-Петербург, ул. Калинина, дом 2, корпус 4, литера А.