

## Features

- 6-bit, 0.5 dB LSB, 31.5 dB range
- DC to 30 GHz operation
- Integrated TTL 0/+5V control
- +/- 0.5 dB typical bit error
- Low RMS phase 4.3° @ 20 GHz
- Lead-Free 3 mm 16-lead PQFN package
- ESD protection for all controls and bias

## Description

The MAAD-011021 is a wide band 6-bit digital attenuator covering DC to 30 GHz. The attenuation bit-values are 0.5 dB LSB (least significant bit), 1, 2, 4, 8, and 16 dB for a total attenuation of 31.5 dB. Attenuation error is typically less than +/- 0.5 dB, RMS phase error is less than 5 degrees at 20 GHz, and typical insertion loss is 7.2 dB at 15 GHz. Return loss is typically 12 dB across all frequencies and attenuation states.

The attenuator integrates an inverter to allow a single control for series/shunt attenuation. Inverter requires a -5 V supply ( $V_{CC}$ ) and 17 mA typical, logic is 0 V / +5 V.

The device is also available as bare die; order part number MAAD-011021-0GPDIE.

## Ordering Information<sup>1,2</sup>

Part Number	Package
MAAD-011021	Bulk Part
MAAD-011021-TR0500	500 piece reel
MAAD-011021-SMB	Sample Board

1. Reference Application Note M513 for reel size information.
2. All sample boards include 3 loose parts.

## Functional Schematic

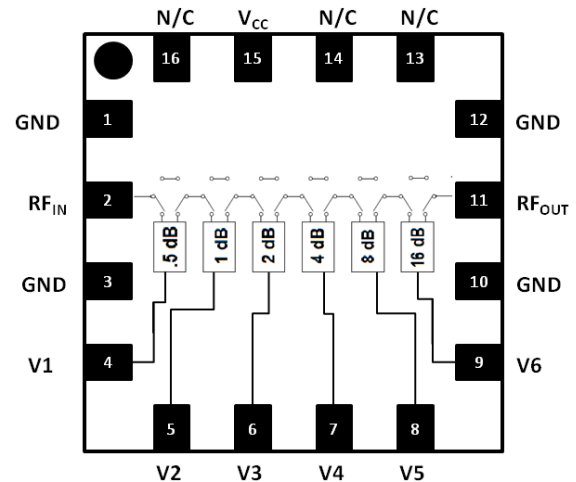

## Pin Configuration<sup>3</sup>

Pin No.	Function	Pin No.	Function
1	Ground	9	V6 (16 dB)
2	RF Input	10	Ground
3	Ground	11	RF Output
4	V1 (0.5 dB)	12	Ground
5	V2 (1 dB)	13	No Connection
6	V3 (2 dB)	14	No Connection
7	V4 (4 dB)	15	$V_{CC}$ -5 V Bias
8	V5 (8 dB)	16	No Connection
		17	Pad <sup>4</sup>

3. MACOM recommends connecting unused package pins to ground.
4. The exposed pad centered on the package bottom must be connected to RF, DC and thermal ground.

\* Restrictions on Hazardous Substances, European Union Directive 2011/65/EU.

## Digital Attenuator, 6-Bit, 0.5 dB LSB step DC - 30 GHz

Rev. V2

### Electrical Specifications:

$T_A = +25^\circ\text{C}$ ,  $V_{CC} = -5\text{ V}$ ,  $Z_0 = 50\ \Omega$  (unless otherwise specified)

Parameter	Test Conditions	Units	Min.	Typ.	Max.
Insertion Loss	DC - 15 GHz	dB	—	6.0	—
	15 - 30 GHz			8.0	—
	1 GHz			5.0	5.5
	10 GHz			7.0	8.0
	15 GHz			7.5	8.5
Return Loss	DC - 30 GHz	dB	—	15	—
Attenuation Bits	10 GHz	dB	0.3	0.4	0.5
	LSB: 0.5 dB		0.8	1.0	1.1
	Bit 2: 1 dB		1.8	2.0	2.2
	Bit 4: 4 dB		3.8	4.0	4.2
	Bit 5: 8 dB		7.6	8.3	8.9
	Bit 6: 16 dB		16.0	17.0	18.0
Attenuation Error RMS	DC - 15 GHz	dB	—	0.3	—
	15 - 30 GHz			1.2	—
Phase Error RMS	DC - 15 GHz	deg	—	2.6	—
	15 - 30 GHz			7.2	—
Input $P_{0.1\text{dB}}$	DC - 30 GHz	dBm	—	24	—
Input IP3	DC - 30 GHz	dBm	—	38	—
Switching Time	—	ns	—	45	—
Control Logic	—	V	—	0 / +5	—
Control Current	each control bit @ +5 V	mA	—	6	—
Supply Current	Supply = -5 V	mA	—	17	45

### Absolute Maximum Ratings<sup>5,6</sup>

Parameter	Absolute Maximum
Input Power	+35 dBm
Operating Voltage	-5 V
Control Voltage	0 / +5 V
Operating Temperature	-40°C to +85°C
Storage Temperature	-65°C to +150°C

- Exceeding any one or combination of these limits may cause permanent damage to this device.
- MACOM does not recommend sustained operation near these survivability limits.

### Handling Procedures

Please observe the following precautions to avoid damage:

### Static Sensitivity

Gallium Arsenide Integrated Circuits are sensitive to electrostatic discharge (ESD) and can be damaged by static electricity. Proper ESD control techniques should be used when handling these Class 1A devices.

## Truth Table<sup>7,8</sup>

V1 0.5 dB	V2 1 dB	V3 2 dB	V4 4 dB	V5 8 dB	V6 16 dB	State
low	low	low	low	low	low	0 dB
high	low	low	low	low	low	0.5 dB
low	high	low	low	low	low	1 dB
low	low	high	low	low	low	2 dB
low	low	low	high	low	low	4 dB
low	low	low	low	high	low	8 dB
low	low	low	low	low	high	16 dB
high	high	high	high	high	high	31.5 dB

7. high = +5 V @ 5.7 mA, low = 0 V @ 1.0 mA.

8. Any combination of the above states will provide attenuation approximately equal to the sum of the bits selected.

## Evaluation Board

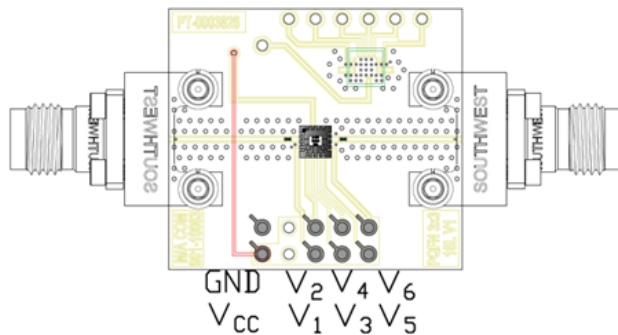

## PCB Layout

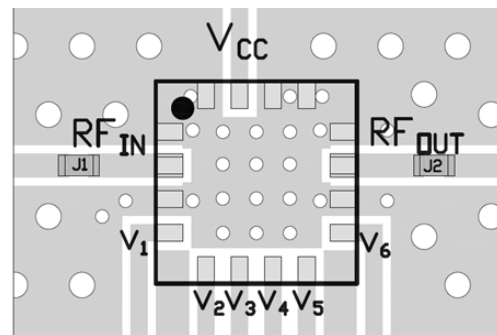

## Parts List

Part	Value	Case Style
J1, J2	0 Ω	0201

## Application Schematic

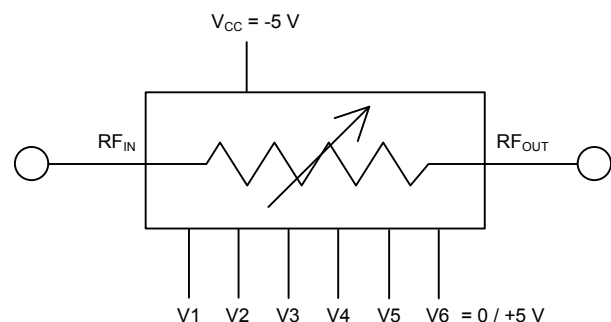

## Typical Performance Curves

**Insertion Loss**

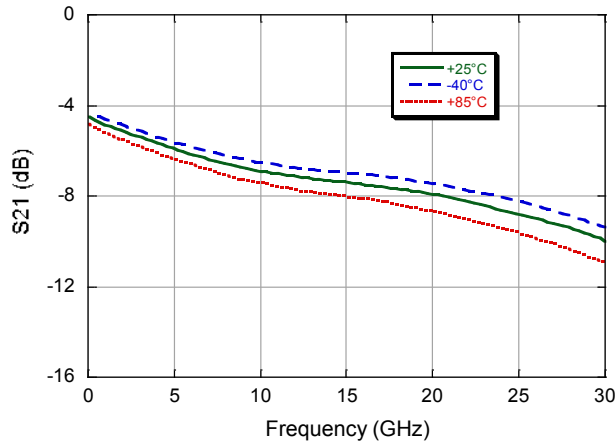

**P0.1dB Compression**

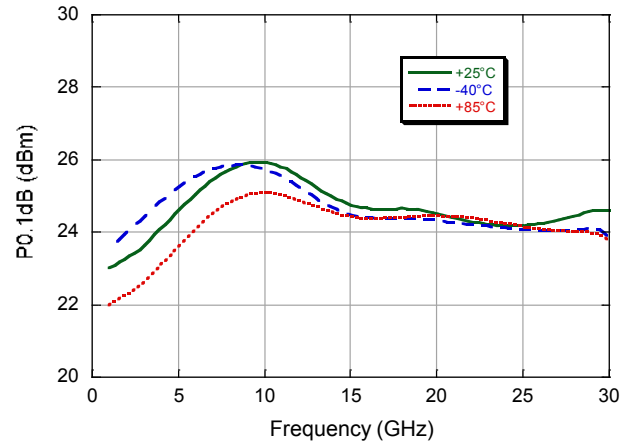

**Maximum Input Return Loss (all states)**

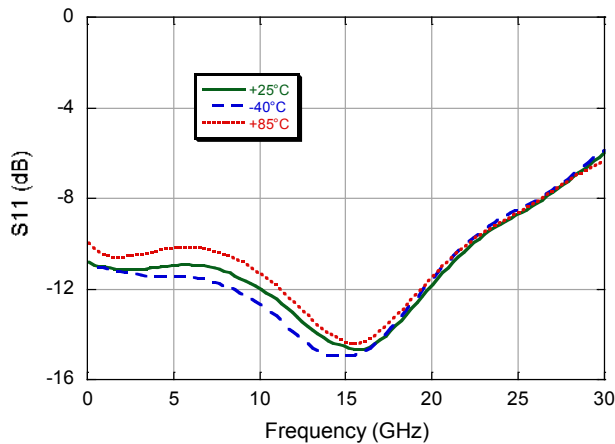

**Maximum Output Return Loss (all states)**

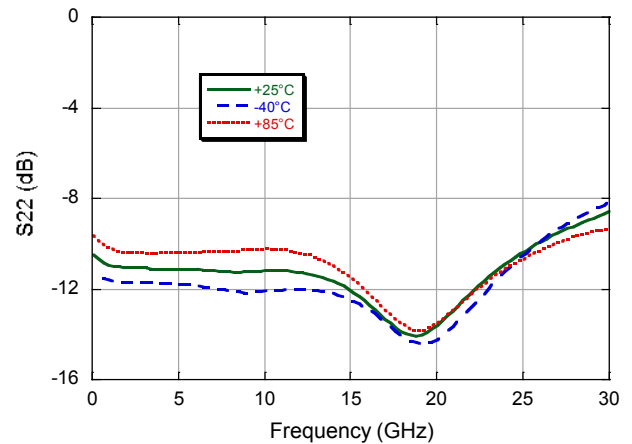

**Input IP3 (reference states)**

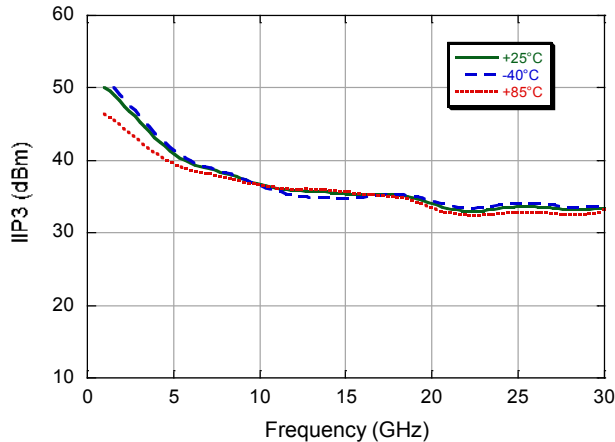

**Noise Figure (reference states)**

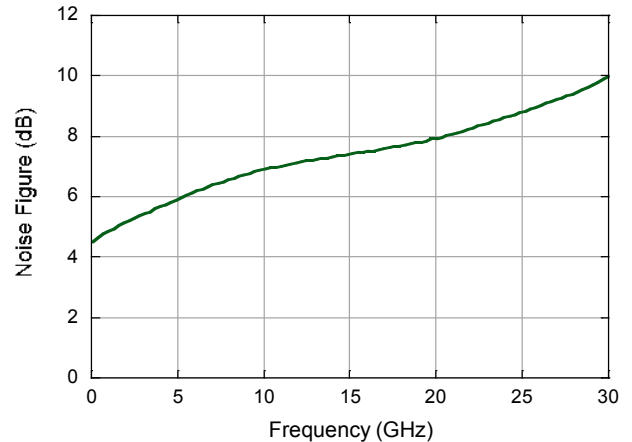

## Typical Performance Curves

**Attenuation**

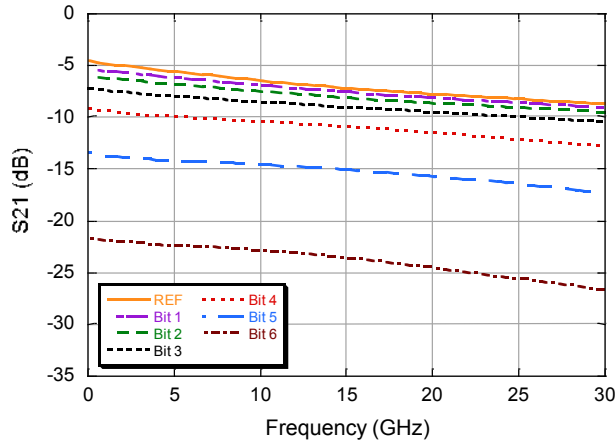

**Relative Attenuation**

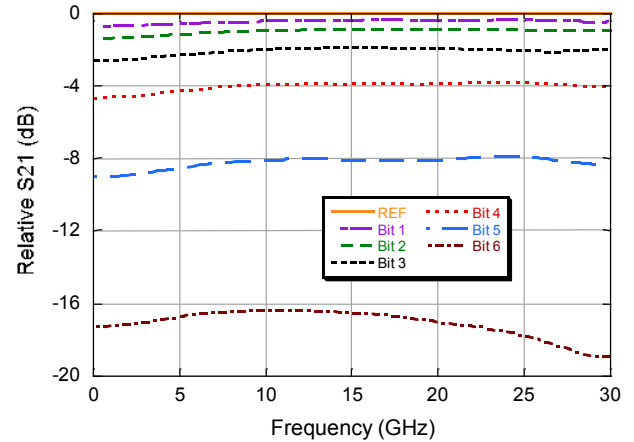

**RMS Attenuation Error**

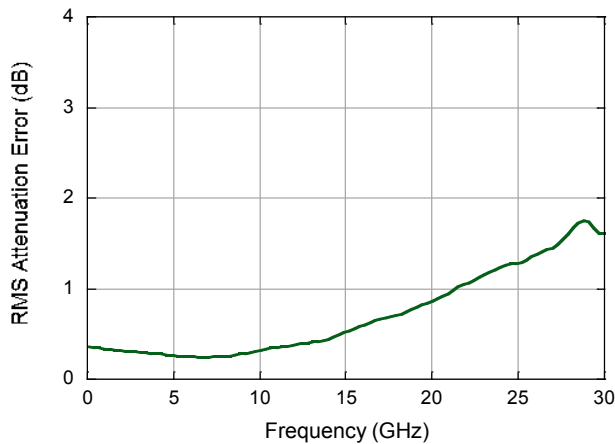

**RMS Phase Error**

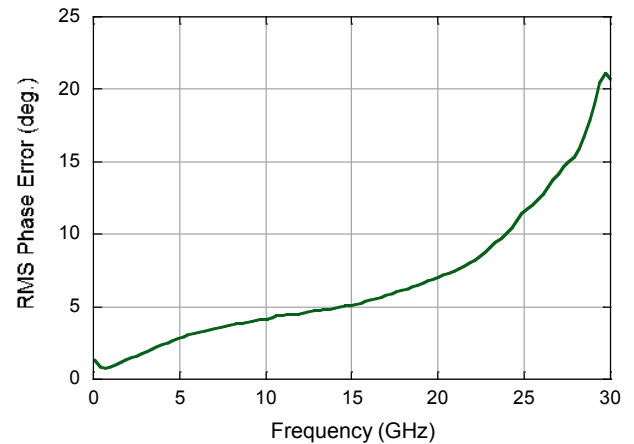

**Relative Attenuation Error**

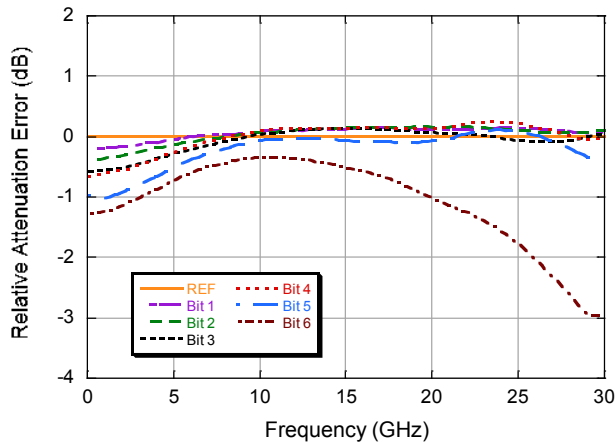

**Relative Phase Error**

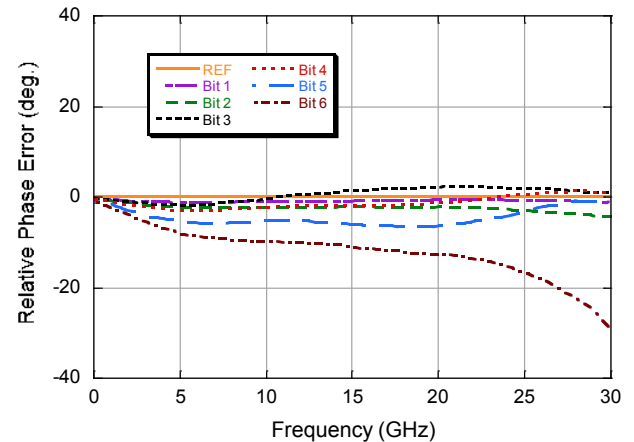

## Typical Performance Curves

Relative Attenuation Error (Bit 1, 2)

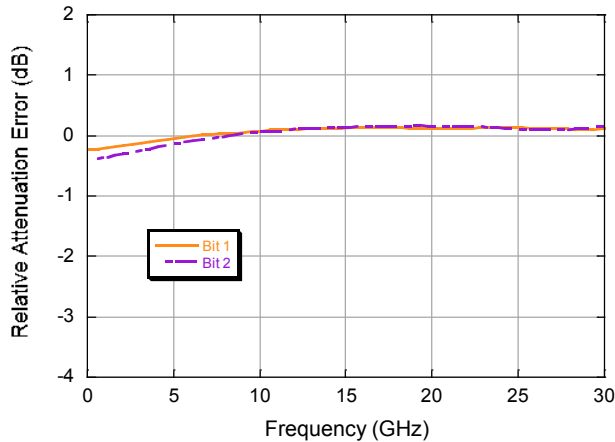

Relative Phase Error (Bit 1, 2)

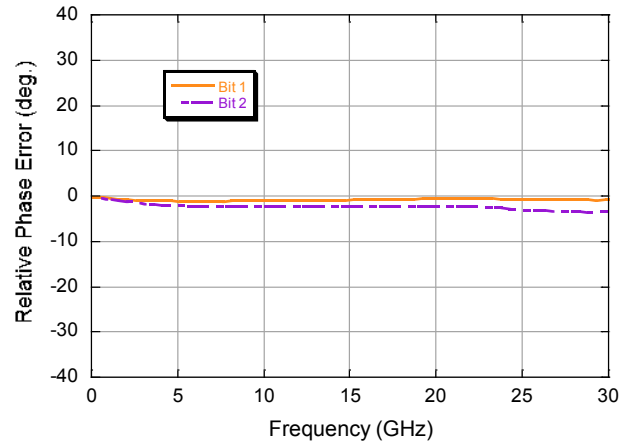

Relative Attenuation Error (Bit 3, 4)

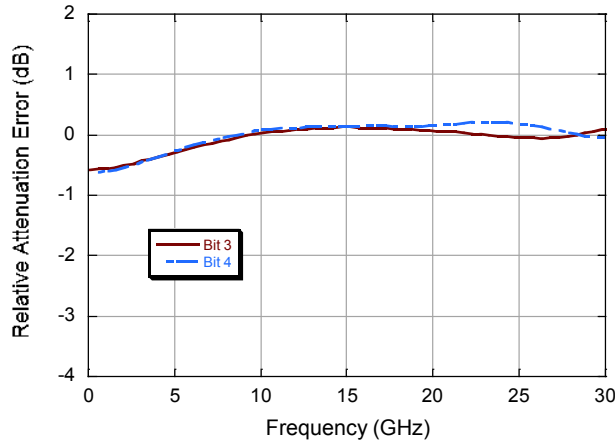

Relative Phase Error (Bit 3, 4)

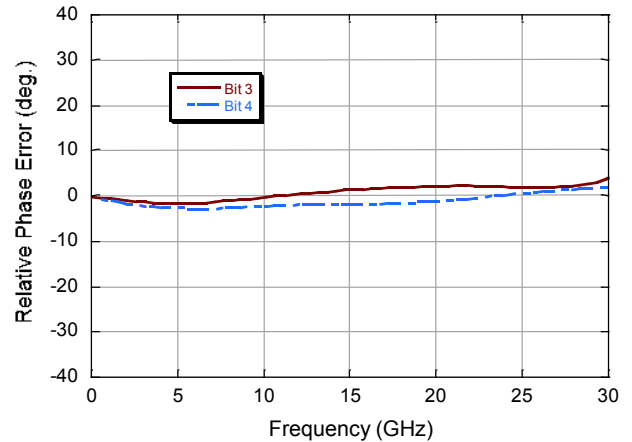

Relative Attenuation Error (Bit 5, 6)

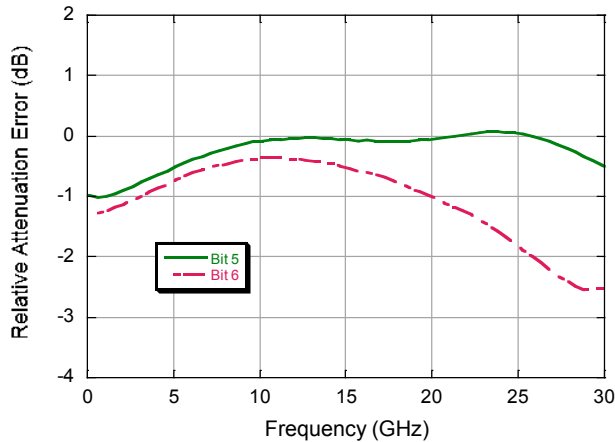

Relative Phase Error (Bit 5, 6)

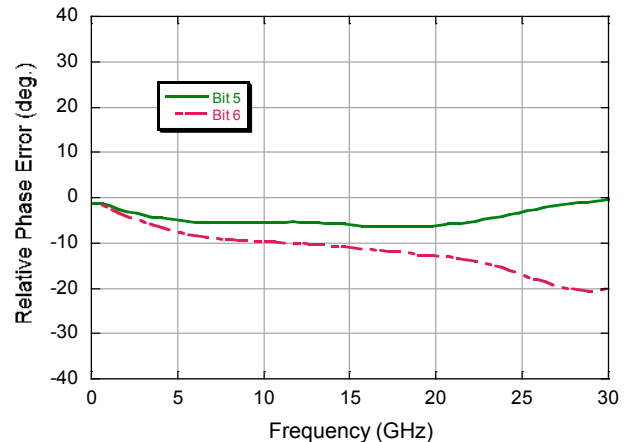

## Typical Performance Curves

**Step Error Between Successive States**

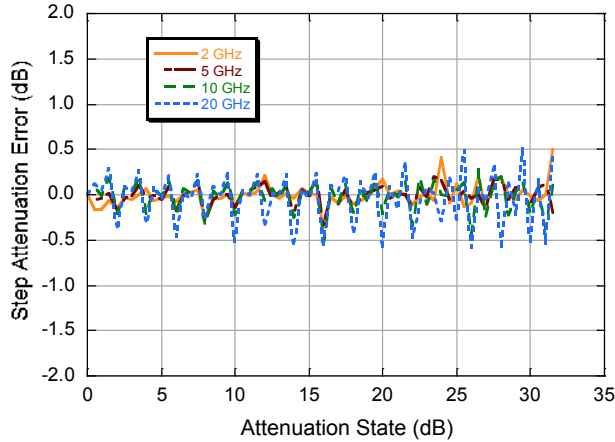

**Switching Time**

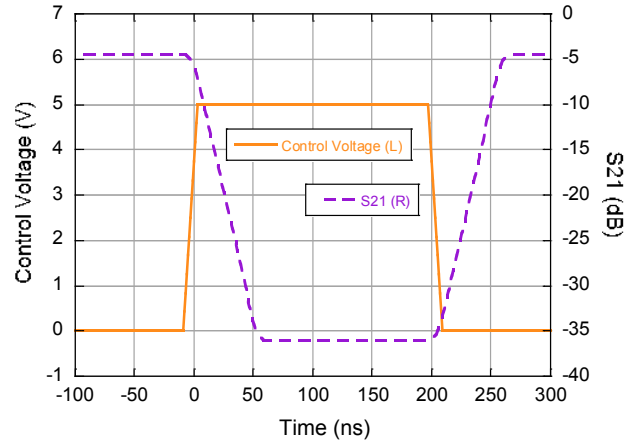

**Phase Error over Attenuation States**

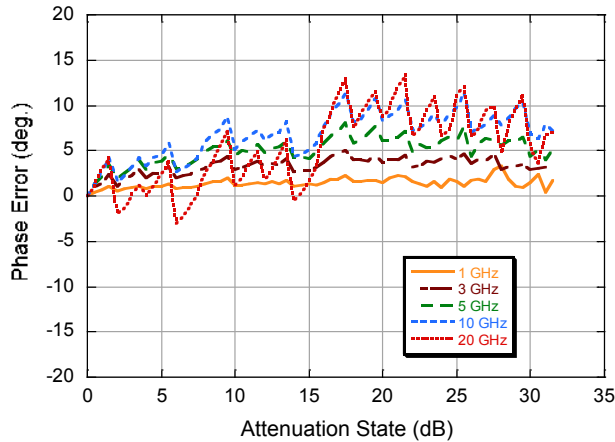

## Lead-Free 3 mm 16-Lead PQFN<sup>†</sup>

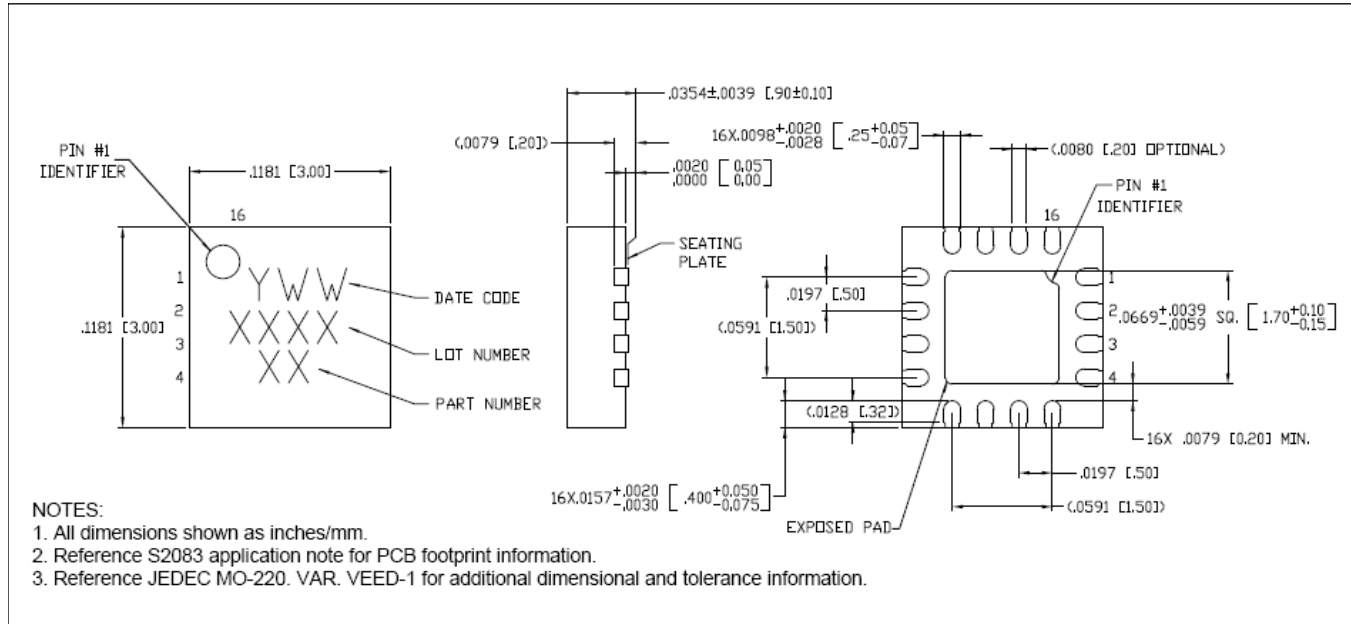

<sup>†</sup> Reference Application Note S2083 for lead-free solder reflow recommendations.  
Meets JEDEC moisture sensitivity level 1 requirements.  
Plating is 100% matte tin over copper.

## Application Information

The MAAD-011021 is designed for extremely wide band and robust attenuation applications. It uses a combination of series and shunt cold channel, multiple-gate FETs to achieve high linearity and accurate attenuation repeatability. We recommend using double bonds at both RF input and output, as well as keeping bondwires as short as possible. This part is the most accurate for X-band applications.

The MAAD-011021 has a built in inverter function which allows a single +5 V / 0 V single control for each bit. This is useful if you require very fast switching times and have +5 V / 0 V available.

The MAAD-011021 is DC-coupled at both RF<sub>IN</sub> and RF<sub>OUT</sub>. If operation at DC is desired, 0 Ω jumpers (or continuous 50 Ω RF lines) should be used in series with RF<sub>IN</sub> and RF<sub>OUT</sub>. Customer should take extra care to ensure that the voltage at both RF<sub>IN</sub> and RF<sub>OUT</sub> are 0 V; excess voltage can damage the part. If operation at DC is not required, simply use series blocking capacitors.





Компания «ЭлектроПласт» предлагает заключение долгосрочных отношений при поставках импортных электронных компонентов на взаимовыгодных условиях!

Наши преимущества:

- Оперативные поставки широкого спектра электронных компонентов отечественного и импортного производства напрямую от производителей и с крупнейших мировых складов;
- Поставка более 17-ти миллионов наименований электронных компонентов;
- Поставка сложных, дефицитных, либо снятых с производства позиций;
- Оперативные сроки поставки под заказ (от 5 рабочих дней);
- Экспресс доставка в любую точку России;
- Техническая поддержка проекта, помощь в подборе аналогов, поставка прототипов;
- Система менеджмента качества сертифицирована по Международному стандарту ISO 9001;
- Лицензия ФСБ на осуществление работ с использованием сведений, составляющих государственную тайну;
- Поставка специализированных компонентов (Xilinx, Altera, Analog Devices, Intersil, Interpoint, Microsemi, Aeroflex, Peregrine, Syfer, Eurofarad, Texas Instrument, Miteq, Cobham, E2V, MA-COM, Hittite, Mini-Circuits, General Dynamics и др.);

Помимо этого, одним из направлений компании «ЭлектроПласт» является направление «Источники питания». Мы предлагаем Вам помощь Конструкторского отдела:

- Подбор оптимального решения, техническое обоснование при выборе компонента;
- Подбор аналогов;
- Консультации по применению компонента;
- Поставка образцов и прототипов;
- Техническая поддержка проекта;
- Защита от снятия компонента с производства.



#### Как с нами связаться

**Телефон:** 8 (812) 309 58 32 (многоканальный)

**Факс:** 8 (812) 320-02-42

**Электронная почта:** [org@eplast1.ru](mailto:org@eplast1.ru)

**Адрес:** 198099, г. Санкт-Петербург, ул. Калинина, дом 2, корпус 4, литера А.