

FEATURES

- Output frequency:** <1 MHz to 1 GHz
- Start-up frequency accuracy:** $\leq \pm 100$ ppm (determined by VCXO reference accuracy)
- Zero delay operation**
 - Input-to-output edge timing:** <150 ps
- Dual VCO dividers**
- 14 outputs:** configurable LVPECL, LVDS, HSTL, and LVC MOS
- 14 dedicated output dividers with jitter-free adjustable delay**
- Adjustable delay:** 63 resolution steps of $\frac{1}{2}$ period of VCO output divider
- Output-to-output skew:** <50 ps
- Duty cycle correction for odd divider settings**
- Automatic synchronization of all outputs on power-up**
- Absolute output jitter:** <150 fs at 122.88 MHz
 - Integration range:** 12 kHz to 20 MHz
- Broadband timing jitter:** 124 fs
- Digital lock detect**
- Nonvolatile EEPROM stores configuration settings**
- SPI- and I²C-compatible serial control port**
- Dual PLL architecture**

PLL1

- Low bandwidth for reference input clock cleanup with external VCXO**
- Phase detector rate of 300 kHz to 75 MHz**
- Redundant reference inputs**
- Auto and manual reference switchover modes**
 - Revertive and nonrevertive switching**
- Loss of reference detection with holdover mode**
- Low noise LVC MOS output from VCXO used for RF/IF synthesizers**

PLL2

- Phase detector rate of up to 250 MHz**
- Integrated low noise VCO**

APPLICATIONS

- LTE and multicarrier GSM base stations**
- Wireless and broadband infrastructure**
- Medical instrumentation**
- Clocking high speed ADCs, DACs, DDSs, DDCs, DUCs, MxFEs**
- Low jitter, low phase noise clock distribution**
- Clock generation and translation for SONET, 10Ge, 10G FC, and other 10 Gbps protocols**
- Forward error correction (G.710)**
- High performance wireless transceivers**
- ATE and high performance instrumentation**

Rev. B

Information furnished by Analog Devices is believed to be accurate and reliable. However, no responsibility is assumed by Analog Devices for its use, nor for any infringements of patents or other rights of third parties that may result from its use. Specifications subject to change without notice. No license is granted by implication or otherwise under any patent or patent rights of Analog Devices. Trademarks and registered trademarks are the property of their respective owners.

FUNCTIONAL BLOCK DIAGRAM

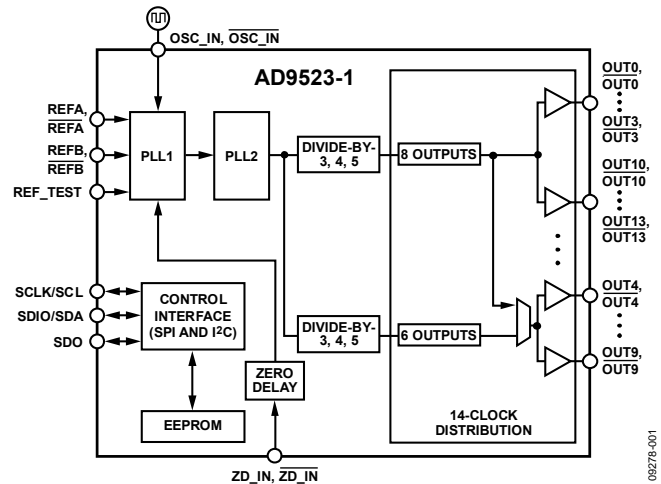

Figure 1.

GENERAL DESCRIPTION

The AD9523-1 provides a low power, multi-output, clock distribution function with low jitter performance, along with an on-chip PLL and VCO with two VCO dividers. The on-chip VCO tunes from 2.94 GHz to 3.1 GHz.

The AD9523-1 is defined to support the clock requirements for long term evolution (LTE) and multicarrier GSM base station designs. It relies on an external VCXO to provide the reference jitter cleanup to achieve the restrictive low phase noise requirements necessary for acceptable data converter SNR performance.

The input receivers, oscillator, and zero delay receiver provide both single-ended and differential operation. When connected to a recovered system reference clock and a VCXO, the device generates 14 low noise outputs with a range of 1 MHz to 1 GHz, and one dedicated buffered output from the input PLL (PLL1). The frequency and phase of one clock output relative to another clock output can be varied by means of a divider phase select function that serves as a jitter-free, coarse timing adjustment in increments that are equal to half the period of the signal coming out of the VCO.

An in-package EEPROM can be programmed through the serial interface to store user-defined register settings for power-up and chip reset.

TABLE OF CONTENTS

Features	1	Input/Output Termination Recommendations.....	19
Applications.....	1	Terminology.....	20
Functional Block Diagram	1	Theory of Operation	21
General Description	1	Detailed Block Diagram	21
Revision History	2	Overview	21
Specifications.....	3	Component Blocks—Input PLL (PLL1).....	22
Conditions.....	3	Component Blocks—Output PLL (PLL2)	23
Supply Current.....	3	Clock Distribution	25
Power Dissipation.....	5	Zero Delay Operation.....	27
REFA, REFA, REFB, REFB, OSC_IN, OSC_IN, and ZD_IN, ZD_IN Input Characteristics	6	Serial Control Port	28
OSC_CTRL Output Characteristics	6	SPI/I ² C Port Selection.....	28
REF_TEST Input Characteristics	6	I ² C Serial Port Operation.....	28
PLL1 Output Characteristics	7	SPI Serial Port Operation.....	31
OUT0, OUT0 to OUT13, OUT13 Distribution Output Characteristics	7	SPI Instruction Word (16 Bits).....	32
Timing Alignment Characteristics.....	8	SPI MSB/LSB First Transfers	32
Jitter and Noise Characteristics	9	EEPROM Operations.....	35
PLL2 Characteristics	9	Writing to the EEPROM	35
Logic Input Pins—PD, SYNC, RESET, EEPROM_SEL, REF_SEL	9	Reading from the EEPROM	35
Status Output Pins—STATUS1, STATUS0	10	Programming the EEPROM Buffer Segment.....	36
Serial Control Port—SPI Mode	10	Power Dissipation and Thermal Considerations	38
Serial Control Port—I ² C Mode	11	Clock Speed and Driver Mode	38
Absolute Maximum Ratings.....	12	Evaluation of Operating Conditions.....	38
Thermal Resistance	12	Thermally Enhanced Package Mounting Guidelines.....	39
ESD Caution.....	12	Control Registers.....	40
Pin Configuration and Function Descriptions.....	13	Control Register Map	40
Typical Performance Characteristics	16	Control Register Map Bit Descriptions	45
		Outline Dimensions	58
		Ordering Guide	58

REVISION HISTORY

3/11—Rev. A to Rev. B

Added Table Summary, Table 8	7
Changes to Figure 24.....	21
Changes to EEPROM Operations Section and Writing to the EEPROM Section.....	35
Changes to Addr (Hex) 0x01A, Bits[4:3], Table 30.....	40
Changes to Bits[4:3], Table 40.....	47

12/10—Rev. 0 to Rev. A

Changes to General Description Section	1
Changes to Frequency Range, Table 11	9
Changes to PLL2 General Description Section.....	23
Changes to Table 47, Address 0x0F3, Bit 1	48

10/10—Revision 0: Initial Version

SPECIFICATIONS

$f_{VCO} = 122.88$ MHz single-ended, REFA and REFB on differential at 30.72 MHz, $f_{VCO} = 2949.12$ MHz, doubler is on, unless otherwise noted. Typical is given for $VDD = 3.3$ V \pm 5%, and $T_A = 25^\circ\text{C}$, unless otherwise noted. Minimum and maximum values are given over the full VDD and T_A (-40°C to $+85^\circ\text{C}$) variation, as listed in Table 1.

CONDITIONS

Table 1.

Parameter	Min	Typ	Max	Unit	Test Conditions/Comments
SUPPLY VOLTAGE					
VDD3_PLL, Supply Voltage for PLL1 and PLL2	3.135	3.3	3.465	V	3.3 V \pm 5%
VDD3_VCO, Supply Voltage for VCO	3.135	3.3	3.465	V	3.3 V \pm 5%
VDD3_REF, Supply Voltage Clock Output Drivers Reference	3.135	3.3	3.465	V	3.3 V \pm 5%
VDD3_OUT[x:y], ¹ Supply Voltage Clock Output Drivers	3.135	3.3	3.465	V	3.3 V \pm 5%
VDD1.8_OUT[x:y], ¹ Supply Voltage Clock Dividers	1.768	1.8	1.832	V	1.8 V \pm 5%
TEMPERATURE RANGE, T_A	-40	+25	+85	$^\circ\text{C}$	

¹ x and y are the pair of differential outputs that share the same power supply. For example, VDD3_OUT[0:1] is Supply Voltage Clock Output OUT0, $\overline{\text{OUT0}}$ (Pin 68 and Pin 67, respectively) and Supply Voltage Clock Output OUT1, $\overline{\text{OUT1}}$ (Pin 65 and Pin 64, respectively).

SUPPLY CURRENT

Table 2.

Parameter	Min	Typ	Max	Unit	Test Conditions/Comments
SUPPLIES OTHER THAN CLOCK OUTPUT DRIVERS					
VDD3_PLL, Supply Voltage for PLL1 and PLL2		37	41.9	mA	Decreases by 9 mA typical if REFB is turned off
VDD3_VCO, Supply Voltage for VCO and VCO Divider M1		70	75.8	mA	All outputs use VCO Divider M1
VDD3_REF, Supply Voltage Clock Output Drivers Reference					
VCO Divider M1 Enabled					
LVPECL Mode, LVDS Mode		4	5.1	mA	Use VCO Divider M1; only one output driver is turned on; for each additional output that is turned on, the current increments by 1.2 mA maximum
HSTL Mode, CMOS Mode		3	3.6	mA	Use VCO Divider M1; values are independent of the number of outputs turned on
VCO Divider M2 Enabled					
LVPECL Mode, LVDS Mode		26	30.1	mA	Use VCO Divider M2; only one output driver is turned on; for each additional output that is turned on, the current increments by 1.2 mA maximum
HSTL Mode, CMOS Mode		24.5	28.6	mA	Use VCO Divider M2; values are independent of the number of outputs turned on
VDD1.8_OUT[x:y], ¹ Supply Voltage Clock Dividers		3.2	5.8	mA	Current for each divider: $f = 122.88$ MHz
VDD1.8_OUT[x:y], ¹ Supply Voltage Clock Dividers		6.4	12	mA	Current for each divider: $f = 983.04$ MHz
CLOCK OUTPUT DRIVERS—LOWER POWER MODE OFF					
LVDS Mode, 7 mA					Channel x control register, Bit 4 = 0
VDD3_OUT[x:y], ¹ Supply Voltage Clock Output Drivers		11.5	13.2	mA	$f = 122.88$ MHz
VDD3_OUT[x:y], ¹ Supply Voltage Clock Output Drivers		40	45	mA	$f = 983.04$ MHz
LVDS Mode, 3.5 mA					
VDD3_OUT[x:y], ¹ Supply Voltage Clock Output Drivers		6.5	7.5	mA	$f = 122.88$ MHz
VDD3_OUT[x:y], ¹ Supply Voltage Clock Output Drivers		23	26.3	mA	$f = 983.04$ MHz
LVPECL Mode					
VDD3_OUT[x:y], ¹ Supply Voltage Clock Output Drivers		13	14.4	mA	$f = 122.88$ MHz
VDD3_OUT[x:y], ¹ Supply Voltage Clock Output Drivers		41	46.5	mA	$f = 983.04$ MHz

AD9523-1

Parameter	Min	Typ	Max	Unit	Test Conditions/Comments
HSTL Mode, 16 mA					
VDD3_OUT[x:y], ¹ Supply Voltage Clock Output Drivers		20	24.2	mA	f = 122.88 MHz
VDD3_OUT[x:y], ¹ Supply Voltage Clock Output Drivers		50	59.1	mA	f = 983.04 MHz
HSTL Mode, 8 mA					
VDD3_OUT[x:y], ¹ Supply Voltage Clock Output Drivers		14	16.7	mA	f = 122.88 MHz
VDD3_OUT[x:y], ¹ Supply Voltage Clock Output Drivers		42.5	49	mA	f = 983.04 MHz
CMOS Mode (Single-Ended)					
VDD3_OUT[x:y], ¹ Supply Voltage Clock Output Drivers		2	2.4	mA	f = 15.36 MHz, 10 pF Load
CLOCK OUTPUT DRIVERS—LOWER POWER MODE ON					Channel x control register, Bit 4 = 1
LVDS Mode, 7 mA					
VDD3_OUT[x:y], ¹ Supply Voltage Clock Output Drivers		10	10.8	mA	f = 122.88 MHz
VDD3_OUT[x:y], ¹ Supply Voltage Clock Output Drivers		27	29.8	mA	f = 983.04 MHz
LVDS Mode, 3.5 mA					
VDD3_OUT[x:y], ¹ Supply Voltage Clock Output Drivers		6.5	7.5	mA	f = 122.88 MHz
VDD3_OUT[x:y], ¹ Supply Voltage Clock Output Drivers		23	26.3	mA	f = 983.04 MHz
LVPECL Mode					
VDD3_OUT[x:y], ¹ Supply Voltage Clock Output Drivers		11	12.4	mA	f = 122.88 MHz
VDD3_OUT[x:y], ¹ Supply Voltage Clock Output Drivers		28	31.2	mA	f = 983.04 MHz
HSTL Mode, 16 mA					
VDD3_OUT[x:y], ¹ Supply Voltage Clock Output Drivers		20	24.3	mA	f = 122.88 MHz
VDD3_OUT[x:y], ¹ Supply Voltage Clock Output Drivers		50	59.1	mA	f = 983.04 MHz
HSTL Mode, 8 mA					
VDD3_OUT[x:y], ¹ Supply Voltage Clock Output Drivers		11	12.7	mA	f = 122.88 MHz
VDD3_OUT[x:y], ¹ Supply Voltage Clock Output Drivers		27	31.8	mA	f = 983.04 MHz

¹ x and y are the pair of differential outputs that share the same power supply. For example, VDD3_OUT[0:1] is Supply Voltage Clock Output OUT0, $\overline{\text{OUT0}}$ (Pin 68 and Pin 67, respectively) and Supply Voltage Clock Output OUT1, $\overline{\text{OUT1}}$ (Pin 65 and Pin 64, respectively).

POWER DISSIPATION

Table 3.

Parameter	Min	Typ	Max	Unit	Test Conditions/Comments
POWER DISSIPATION					Does not include power dissipated in termination resistors
Typical Configuration		898	984.7	mW	Clock distribution outputs running as follows: 7 LVPECL at 122.88 MHz, 3 LVDS (3.5 mA) at 61.44 MHz, 3 LVDS (3.5 mA) at 245.76 MHz, 1 single-ended CMOS 10 pF load at 122.88 MHz, 1 differential input reference at 30.72 MHz; $f_{VCO} = 122.88$ MHz, $f_{VCO} = 2949.12$ MHz, VCO Divider M1 at 3, and VCO Divider M2 is off; PLL2 BW = 530 kHz
\overline{PD} , Power-Down		74	98.2	mW	\overline{PD} pin pulled low, with typical configuration conditions
INCREMENTAL POWER DISSIPATION					
Base Typical Configuration		393	434.7	mW	Absolute total power with clock distribution; 1 LVPECL output (OUT0) running at 122.88 MHz; 1 differential input reference at 30.72 MHz; $f_{VCO} = 122.88$ MHz, $f_{VCO} = 2949.12$ MHz, VCO Divider M1 at 3; VCO Divider M2 is off
Switched to One Input, Reference Single-Ended Mode		-28.5	-8	mW	Running at 30.72 MHz
Switched to Two Inputs, Reference Differential Mode		26	44.6	mW	Running at 30.72 MHz
Switched to Two Inputs, Reference Single-Ended Mode		-27.5	-5.1	mW	Running at 30.72 MHz
VCO Divider M2		76	88.3	mW	Incremental power increase VCO Divider M2 (OUT4) from base typical
Output Distribution, Driver On LVDS Mode					Incremental power increase (OUT1) from base typical
3.5 mA		29	34.8	mW	Single 3.5 mA LVDS output at 122.88 MHz
		88	105.6	mW	Single 3.5 mA LVDS output at 983.04 MHz
7 mA		43	50	mW	Single 7 mA LVDS output at 122.88 MHz
		141	164	mW	Single 7 mA LVDS output at 983.04 MHz
LVPECL Mode		46	51	mW	Single LVPECL output at 122.88 MHz
		144	159	mW	Single LVPECL output at 983.04 MHz
HSTL Mode					
8 mA		44	51	mW	Single 8 mA HSTL output at 122.88 MHz
		143	165	mW	Single 8 mA HSTL output at 983.04 MHz
16 mA		48	55	mW	Single 16 mA HSTL output at 122.88 MHz
		153	176	mW	Single 16 mA HSTL output at 983.04 MHz
CMOS Mode		6.6	7.9	mW	Single 3.3 V CMOS output at 15.36 MHz
		9.9	11.9	mW	Dual complementary 3.3 V CMOS output at 15.36 MHz
		9.9	11.9	mW	Dual in-phase 3.3 V CMOS output at 15.36 MHz
Output Distribution, Driver On LVDS Mode					Lower power mode on, (Channel x control register, Bit 4 = 1)
3.5 mA		28.5	33.6	mW	Single 3.5 mA LVDS output at 122.88 MHz
		88	105.6	mW	Single 3.5 mA LVDS output at 983.04 MHz
7 mA		37	42.9	mW	Single 7 mA LVDS output at 122.88 MHz
		98	113.7	mW	Single 7 mA LVDS output at 983.04 MHz
LVPECL Mode		40.5	46	mW	Single LVPECL output at 122.88 MHz
		100	110	mW	Single LVPECL output at 983.04 MHz
HSTL Mode					
8 mA		34	39.1	mW	Single 8 mA HSTL output at 122.88 MHz
		94	108.1	mW	Single 8 mA HSTL output at 983.04 MHz
16 mA		48	55.2	mW	Single 16 mA HSTL output at 122.88 MHz
		153	176	mW	Single 16 mA HSTL output at 983.04 MHz

AD9523-1

REFA, REFA, REFB, REFB, OSC_IN, OSC_IN, AND ZD_IN, ZD_IN INPUT CHARACTERISTICS

Table 4.

Parameter	Min	Typ	Max	Unit	Test Conditions/Comments
DIFFERENTIAL MODE					
Input Frequency Range			400	MHz	Minimum limit imposed for jitter performance
Input Slew Rate (OSC_IN)	400			V/ μ s	
Common-Mode Internally Generated Input Voltage	0.6	0.7	0.8	V	For dc-coupled LVDS (maximum swing) Capacitive coupling required; can accommodate single-ended input by ac grounding of unused input; instantaneous voltage on either pin must not exceed the 1.8V dc supply rails
Input Common-Mode Range	1.025		1.475	V	
Differential Input Voltage, Sensitivity Frequency < 250 MHz	100			mV p-p	
Differential Input Voltage, Sensitivity Frequency > 250 MHz	200			mV p-p	
Differential Input Resistance		4.8		k Ω	Duty cycle limits are set by pulse width high and pulse width low
Differential Input Capacitance		1		pF	
Duty Cycle					
Pulse Width Low	1			ns	
Pulse Width High	1			ns	
CMOS MODE, SINGLE-ENDED INPUT					
Input Frequency Range			250	MHz	Duty cycle limits are set by pulse width high and pulse width low
Input High Voltage	2.0			V	
Input Low Voltage			0.8	V	
Input Capacitance		1		pF	
Duty Cycle					
Pulse Width Low	1.6			ns	
Pulse Width High	1.6			ns	

OSC_CTRL OUTPUT CHARACTERISTICS

Table 5.

Parameter	Min	Typ	Max	Unit	Test Conditions/Comments
OUTPUT VOLTAGE					
High	VDD3_PLL – 0.15			V	R _{LOAD} > 20 k Ω
Low			150	mV	

REF_TEST INPUT CHARACTERISTICS

Table 6.

Parameter	Min	Typ	Max	Unit	Test Conditions/Comments
REF_TEST INPUT					
Input Frequency Range			250	MHz	
Input High Voltage	2.0			V	
Input Low Voltage			0.8	V	

PLL1 OUTPUT CHARACTERISTICS

Table 7.

Parameter ¹	Min	Typ	Max	Unit	Test Conditions/Comments
MAXIMUM OUTPUT FREQUENCY		250		MHz	
Rise Time/Fall Time (20% to 80%)		387	665	ps	15 pF load
Duty Cycle	45	50	55	%	f = 250 MHz
OUTPUT VOLTAGE HIGH	VDD3_PLL – 0.25			V	Output driver static Load current = 10 mA
	VDD3_PLL – 0.1			V	Load current = 1 mA
OUTPUT VOLTAGE LOW			0.2	V	Output driver static Load current = 10 mA
			0.1	V	Load current = 1 mA

¹ CMOS driver strength: strong (see Table 52).

OUT0, OUT0 TO OUT13, OUT13 DISTRIBUTION OUTPUT CHARACTERISTICS

Duty cycle performance is specified with the invert divider bit set to 1, and the divider phase bits set to 0.5. (For example, for Channel 0, 0x190[7] = 1 and 0x192[7:2] = 1.)

Table 8.

Parameter	Min	Typ	Max	Unit	Test Conditions/Comments
LVPECL MODE					
Maximum Output Frequency		1		GHz	Minimum VCO/maximum dividers
Rise Time/Fall Time (20% to 80%)		117	147	ps	100 Ω termination across output pair
Duty Cycle	47	50	52	%	f < 500 MHz
	43	48	52	%	f = 500 MHz to 800 MHz
	40	49	54	%	f = 800 MHz to 1 GHz
Differential Output Voltage Swing	643	775	924	mV	Magnitude of voltage across pins; output driver static
Common-Mode Output Voltage	VDD – 1.5	VDD – 1.4	VDD – 1.25	V	Output driver static
SCALED HSTL MODE, 16 mA					
Maximum Output Frequency		1		GHz	Minimum VCO/maximum dividers
Rise Time/Fall Time (20% to 80%)		112	141	ps	100 Ω termination across output pair
Duty Cycle	47	50	52	%	f < 500 MHz
	44	48	51	%	f = 500 MHz to 800 MHz
	40	49	54	%	f = 800 MHz to 1 GHz
Differential Output Voltage Swing	1.3	1.6	1.7	mV	Nominal supply
Supply Sensitivity		0.6		mV/ mV	Change in output swing vs. VDD3_OUT[x;y] ($\Delta V_{od}/\Delta VDD3$)
Common-Mode Output Voltage	VDD – 1.76	VDD – 1.6	VDD – 1.42	V	
LVDS MODE, 3.5 mA					
Maximum Output Frequency		1		GHz	
Rise Time/Fall Time (20% to 80%)		138	161	ps	100 Ω termination across output pair
Duty Cycle	48	51	53	%	f < 500 MHz
	43	49	53	%	f = 500 MHz to 800 MHz
	41	49	55	%	f = 800 MHz to 1 GHz
Differential Output Voltage Swing					
Balanced	247		454	mV	Voltage swing between output pins; output driver static
Unbalanced			50	mV	Absolute difference between voltage swing of normal pin and inverted pin
Common-Mode Output Voltage	1.125		1.375	V	Output driver static
Common-Mode Difference			50	mV	Voltage difference between output pins; output driver static
Short-Circuit Output Current		3.5	24	mA	Output driver static

AD9523-1

Parameter	Min	Typ	Max	Unit	Test Conditions/Comments
CMOS MODE					
Maximum Output Frequency		250		MHz	
Rise Time/Fall Time (20% to 80%)		387	665	ps	15 pF load
Duty Cycle	45	50	55	%	f = 250 MHz
Output Voltage High	VDD – 0.25			V	Output driver static Load current = 10 mA
	VDD – 0.1			V	Load current = 1 mA
Output Voltage Low			0.2	V	Output driver static Load current = 10 mA
			0.1	V	Load current = 1 mA

TIMING ALIGNMENT CHARACTERISTICS

Table 9.

Parameter	Min	Typ	Max	Unit	Test Conditions/Comments
OUTPUT TIMING SKEW					Delay off on all outputs; maximum deviation between rising edges of outputs; all outputs are on, unless otherwise noted
Between Outputs in Same Group ¹ LVPECL, HSTL, and LVDS		30	183	ps	
Between LVPECL, HSTL, and LVDS Outputs					
CMOS					
Between CMOS Outputs		100	300	ps	Single-ended, true phase, high-Z mode
Mean Delta Between Groups ¹		50			
Adjustable Delay	0		63	Steps	Resolution step; for example, 8 × 0.5/1 GHz
Resolution Step		500		ps	½ period of 1 GHz
Zero Delay					
Between Input Clock Edge on REFA or REFB to ZD_IN Input		150	500	ps	PLL1 settings: PFD = 7.68 MHz, I _{CP} = 63.5 μA, R _{ZERO} = 10 kΩ, antibacklash pulse width is at maximum, BW = 40 Hz, REFA and ZD_IN are set to differential mode
Clock Edge, External Zero Delay Mode					

¹ There are three groups of outputs. They are as follows: the top outputs group, consisting of OUT0, OUT1, OUT2, and OUT3; the right outputs group, consisting of OUT4, OUT5, OUT6, OUT7, OUT8, and OUT9; and the bottom outputs group, consisting of OUT10, OUT11, OUT12, and OUT13.

JITTER AND NOISE CHARACTERISTICS

Table 10.

Parameter	Min	Typ	Max	Unit	Test Conditions/Comments
OUTPUT ABSOLUTE RMS TIME JITTER					Application example based on a typical setup (see Table 3); f = 122.88 MHz
LVPECL Mode, HSTL Mode, LVDS Mode					
		109		fs	Integrated BW = 200 kHz to 5 MHz
		115		fs	Integrated BW = 200 kHz to 10 MHz
		150		fs	Integrated BW = 12 kHz to 20 MHz
		177		fs	Integrated BW = 10 kHz to 61 MHz
		187		fs	Integrated BW = 1 kHz to 61 MHz
		124		fs	Integrated BW = 1 MHz to 61 MHz

PLL2 CHARACTERISTICS

Table 11.

Parameter	Min	Typ	Max	Unit	Test Conditions/Comments
VCO (ON CHIP)					
Frequency Range	2940		3100	MHz	
Gain		45		MHz/V	
PLL2 FIGURE OF MERIT (FOM)		-226		dBc/Hz	
MAXIMUM PFD FREQUENCY					
Antibacklash Pulse Width					
Minimum and Low			250	MHz	
Maximum and High			125	MHz	

LOGIC INPUT PINS— $\overline{\text{PD}}$, $\overline{\text{SYNC}}$, $\overline{\text{RESET}}$, $\overline{\text{EEPROM_SEL}}$, $\overline{\text{REF_SEL}}$

Table 12.

Parameter	Min	Typ	Max	Unit	Test Conditions/Comments
VOLTAGE					
Input High	2.0			V	
Input Low			0.8	V	
INPUT LOW CURRENT		±80	±250	μA	The minus sign indicates that, due to the internal pull-up resistor, current is flowing out of the AD9523-1
CAPACITANCE		3		pF	
RESET TIMING					
Pulse Width Low	50			ns	
Inactive to Start of Register Programming	100			ns	
SYNC TIMING					
Pulse Width Low	1.5			ns	High speed clock is the CLK input signal

AD9523-1

STATUS OUTPUT PINS—STATUS1, STATUS0

Table 13.

Parameter	Min	Typ	Max	Unit	Test Conditions/Comments
VOLTAGE					
Output High	2.94			V	
Output Low			0.4	V	

SERIAL CONTROL PORT—SPI MODE

Table 14.

Parameter	Min	Typ	Max	Unit	Test Conditions/Comments
$\overline{\text{CS}}$ (INPUT)					$\overline{\text{CS}}$ has an internal 40 k Ω pull-up resistor
Voltage					
Input Logic 1		2.0		V	
Input Logic 0		0.8		V	
Current					
Input Logic 1		30		μA	The minus sign indicates that, due to the internal pull-up resistor, current is flowing out of the AD9523-1
Input Logic 0		-110		μA	
Input Capacitance		2		pF	
SCLK (INPUT) IN SPI MODE					
Voltage					
Input Logic 1		2.0		V	
Input Logic 0		0.8		V	
Current					
Input Logic 1		240		μA	
Input Logic 0		1		μA	
Input Capacitance		2		pF	
SDIO (WHEN INPUT IS IN BIDIRECTIONAL MODE)					
Voltage					
Input Logic 1		2.0		V	
Input Logic 0		0.8		V	
Current					
Input Logic 1		1		μA	
Input Logic 0		1		μA	
Input Capacitance		2		pF	
SDIO, SDO (OUTPUTS)					
Output Logic 1 Voltage	2.7			V	
Output Logic 0 Voltage			0.4	V	
TIMING					
Clock Rate (SCLK, $1/t_{\text{SCLK}}$)			25	MHz	
Pulse Width High, t_{HIGH}	8			ns	
Pulse Width Low, t_{LOW}	12			ns	
SDIO to SCLK Setup, t_{DS}	3.3			ns	
SCLK to SDIO Hold, t_{DH}	0			ns	
SCLK to Valid SDIO and SDO, t_{DV}			14	ns	
$\overline{\text{CS}}$ to SCLK Setup, t_{s}	10			ns	
$\overline{\text{CS}}$ to SCLK Setup and Hold, $t_{\text{s}}, t_{\text{c}}$	0			ns	
$\overline{\text{CS}}$ Minimum Pulse Width High, t_{PWH}	6			ns	

SERIAL CONTROL PORT—I²C MODE

VDD = VDD3_REF, unless otherwise noted.

Table 15.

Parameter	Min	Typ	Max	Unit	Test Conditions/Comments
SDA, SCL (WHEN INPUTTING DATA)					
Input Logic 1 Voltage	0.7 × VDD			V	
Input Logic 0 Voltage			0.3 × VDD	V	
Input Current with an Input Voltage Between 0.1 × VDD and 0.9 × VDD	-10		+10	μA	
Hysteresis of Schmitt Trigger Inputs	0.015 × VDD			V	
Pulse Width of Spikes That Must Be Suppressed by the Input Filter, t _{SPIKE}			50	ns	
SDA (WHEN OUTPUTTING DATA)					
Output Logic 0 Voltage at 3 mA Sink Current			0.4	V	
Output Fall Time from VIH _{MIN} to VIL _{MAX} with a Bus Capacitance from 10 pF to 400 pF	20 + 0.1 C _B ¹		250	ns	
TIMING					
Clock Rate (SCL, f _{I2C})			400	kHz	Note that all I ² C timing values are referred to VIH _{MIN} (0.3 × VDD) and VIL _{MAX} levels (0.7 × VDD)
Bus Free Time Between a Stop and Start Condition, t _{IDLE}	1.3			μs	
Setup Time for a Repeated Start Condition, t _{SET; STR}	0.6			μs	After this period, the first clock pulse is generated
Hold Time (Repeated) Start Condition, t _{HLD; STR}	0.6			μs	
Setup Time for a Stop Condition, t _{SET; STP}	0.6			μs	
Low Period of the SCL Clock, t _{LOW}	1.3			μs	
High Period of the SCL Clock, t _{HIGH}	0.6			μs	
SCL, SDA Rise Time, t _{RISE}	20 + 0.1 C _B ¹		300	ns	This is a minor deviation from the original I ² C specification of 0 ns minimum ²
SCL, SDA Fall Time, t _{FALL}	20 + 0.1 C _B ¹		300	ns	
Data Setup Time, t _{SET; DAT}	100			ns	
Data Hold Time, t _{HLD; DAT}	100		880	ns	
Capacitive Load for Each Bus Line, C _B ¹			400	pF	

¹ C_B is the capacitance of one bus line in picofarads (pF).² According to the original I²C specification, an I²C master must also provide a minimum hold time of 300 ns for the SDA signal to bridge the undefined region of the SCL falling edge.

ABSOLUTE MAXIMUM RATINGS

Table 16.

Parameter	Rating
VDD3_PLL, VDD3_REF, VDD3_OUT[x;y], LDO_VCO to GND	−0.3 V to +3.6 V
REFA, REF \bar{A} , REFB, REF \bar{B} to GND	−0.3 V to +3.6 V
SCLK/SCL, SDIO/SDA, SDO, \bar{CS} to GND	−0.3 V to +3.6 V
OUT0, $\bar{OUT0}$, OUT1, $\bar{OUT1}$, OUT2, $\bar{OUT2}$, OUT3, $\bar{OUT3}$, OUT4, $\bar{OUT4}$, OUT5, $\bar{OUT5}$, OUT6, $\bar{OUT6}$, OUT7, $\bar{OUT7}$, OUT8, $\bar{OUT8}$, OUT9, $\bar{OUT9}$, OUT10, $\bar{OUT10}$, OUT11, $\bar{OUT11}$, OUT12, $\bar{OUT12}$, OUT13, $\bar{OUT13}$ to GND	−0.3 V to +3.6 V
SYNC, \bar{RESET} , \bar{PD} , REF_SEL to GND	−0.3 V to +3.6 V
STATUS0, STATUS1 to GND	−0.3 V to +3.6 V
SP0, SP1, EEPROM_SEL to GND	−0.3 V to +3.6 V
VDD1.8_OUT[x;y], LDO_PLL1, LDO_DIV_M1 to GND	2 V
Junction Temperature ¹	115°C
Storage Temperature Range	−65°C to +150°C
Lead Temperature (10 sec)	300°C

¹ See Table 17 for θ_{JA} .

Stresses above those listed under Absolute Maximum Ratings may cause permanent damage to the device. This is a stress rating only; functional operation of the device at these or any other conditions above those indicated in the operational section of this specification is not implied. Exposure to absolute maximum rating conditions for extended periods may affect device reliability.

THERMAL RESISTANCE

θ_{JA} is specified for the worst-case conditions, that is, a device soldered in a circuit board for surface-mount packages.

Table 17. Thermal Resistance

Package Type	Airflow Velocity (m/sec)	θ_{JA} ^{1,2}	θ_{JC} ^{1,3}	θ_{JB} ^{1,4}	Ψ_{JT} ^{1,2}	Unit
72-Lead LFCSP, 10 mm × 10 mm	0	21.3	1.7	12.6	0.1	°C/W
	1.0	20.1			0.2	°C/W
	2.5	18.1			0.3	°C/W

¹ Per JEDEC 51-7, plus JEDEC 51-5 2S2P test board.² Per JEDEC JESD51-2 (still air) or JEDEC JESD51-6 (moving air).³ Per MIL-Std 883, Method 1012.1.⁴ Per JEDEC JESD51-8 (still air).

Additional power dissipation information can be found in the Power Dissipation and Thermal Considerations section.

ESD CAUTION



ESD (electrostatic discharge) sensitive device.

Charged devices and circuit boards can discharge without detection. Although this product features patented or proprietary protection circuitry, damage may occur on devices subjected to high energy ESD. Therefore, proper ESD precautions should be taken to avoid performance degradation or loss of functionality.

PIN CONFIGURATION AND FUNCTION DESCRIPTIONS

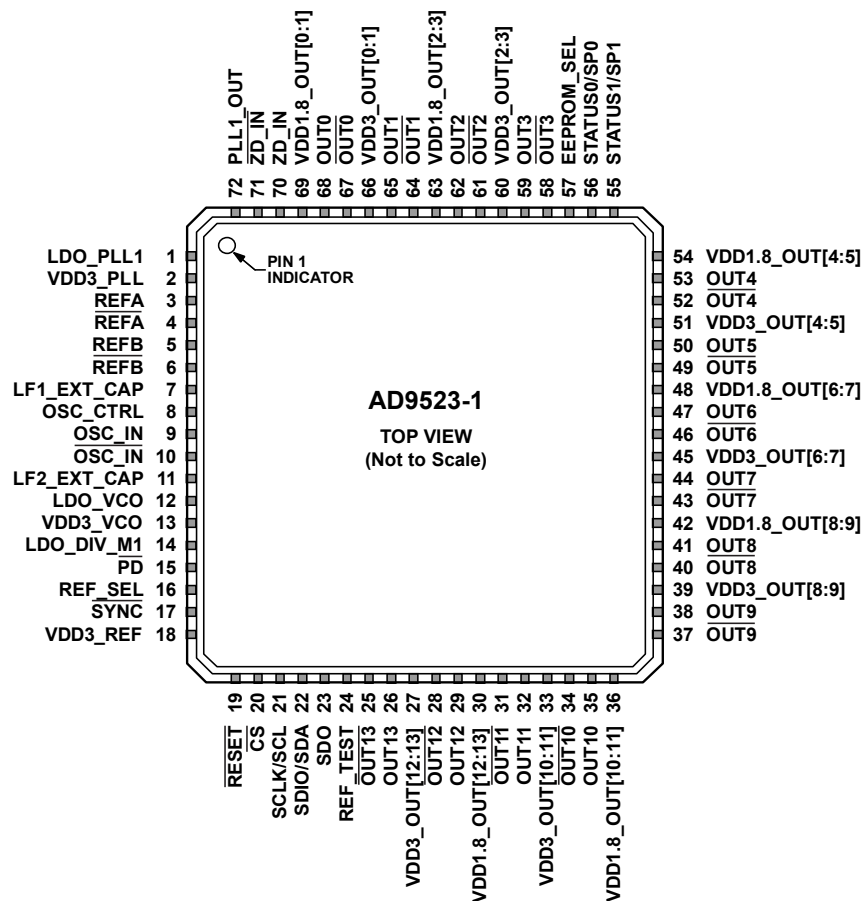

NOTES

1. THE EXPOSED PADDLE IS THE GROUND CONNECTION ON THE CHIP. IT MUST BE SOLDERED TO THE ANALOG GROUND OF THE PCB TO ENSURE PROPER FUNCTIONALITY AND HEAT DISSIPATION, NOISE, AND MECHANICAL STRENGTH BENEFITS.

00276-002

Figure 2. Pin Configuration

Table 18. Pin Function Descriptions

Pin No.	Mnemonic	Type ¹	Description
1	LDO_PLL1	P/O	1.8 V Internal LDO Regulator Decoupling Pin for PLL1. Connect a 0.47 μF decoupling capacitor from this pin to ground. Note that for best performance, the LDO bypass capacitor must be placed in close proximity to the device.
2	VDD3_PLL	P	3.3 V Supply PLL1 and PLL2. Use the same supply as VCXO.
3	REFA	I	Reference Clock Input A. Along with REFA, this pin is the differential input for the PLL reference. Alternatively, this pin can be programmed as a single-ended 3.3 V CMOS input.
4	REFA	I	Complementary Reference Clock Input A. Along with REFA, this pin is the differential input for the PLL reference. Alternatively, this pin can be programmed as a single-ended 3.3V CMOS input.
5	REFB	I	Reference Clock Input B. Along with REFB, this pin is the differential input for the PLL reference. Alternatively, this pin can be programmed as a single-ended 3.3 V CMOS input.
6	REFB	I	Complementary Reference Clock Input B. Along with REFB, this pin is the differential input for the PLL reference. Alternatively, this pin can be programmed as a single-ended 3.3 V CMOS input.
7	LF1_EXT_CAP	O	PLL1 External Loop Filter Capacitor. Connect this pin to ground.
8	OSC_CTRL	O	Oscillator Control Voltage. Connect this pin to the voltage control pin of the external oscillator.
9	OSC_IN	I	PLL1 Oscillator Input. Along with OSC_IN, this pin is the differential input for the PLL reference. Alternatively, this pin can be programmed as a single-ended 3.3 V CMOS input.
10	OSC_IN	I	Complementary PLL1 Oscillator Input. Along with OSC_IN, this pin is the differential input for the PLL reference. Alternatively, this pin can be programmed as a single-ended 3.3 V CMOS input.

AD9523-1

Pin No.	Mnemonic	Type ¹	Description
11	LF2_EXT_CAP	O	PLL2 External Loop Filter Capacitor Connection. Connect capacitor to this pin and the LDO_VCO pin.
12	LDO_VCO	P/O	2.5 V LDO Internal Regulator Decoupling Pin for VCO. Connect a 0.47 μ F decoupling capacitor from this pin to ground. Note that, for best performance, the LDO bypass capacitor must be placed in close proximity to the device.
13	VDD3_VCO	P	3.3 V Supply for VCO and VCO M1 Divider.
14	LDO_DIV_M1	P/O	1.8 V LDO Regulator Decoupling Pin for VCO Divider M1. Connect a 0.47 μ F decoupling capacitor from this pin to ground. Note that, for best performance, the LDO bypass capacitor must be placed in close proximity to the device.
15	$\overline{\text{PD}}$	I	Chip Power-Down, Active Low. This pin has an internal 40 k Ω pull-up resistor.
16	REF_SEL	I	Reference Input Select. This pin has an internal 40 k Ω pull-down resistor.
17	$\overline{\text{SYNC}}$	I	Manual Synchronization. This pin initiates a manual synchronization and has an internal 40 k Ω pull-up resistor.
18	VDD3_REF	P	3.3 V Supply for Output Clock Drivers Reference and VCO Divider M2.
19	$\overline{\text{RESET}}$	I	Digital Input, Active Low. Resets internal logic to default states. This pin has an internal 40 k Ω pull-up resistor.
20	$\overline{\text{CS}}$	I	Serial Control Port Chip Select, Active Low. This pin has an internal 40 k Ω pull-up resistor.
21	SCLK/SCL	I	Serial Control Port Clock Signal for SPI Mode (SCLK) or I ² C Mode (SCL). Data clock for serial programming. This pin has an internal 40 k Ω pull-down resistor in SPI mode but is high impedance in I ² C mode.
22	SDIO/SDA	I/O	Serial Control Port Bidirectional Serial Data In/Data Out for SPI Mode (SDIO) or I ² C Mode (SDA).
23	SDO	O	Serial Data Output. Use this pin to read data in 4-wire mode (high impedance in 3-wire mode). There is no internal pull-up/pull-down resistor on this pin.
24	$\overline{\text{REF_TEST}}$	I	Test Input to PLL1 Phase Detector.
25	$\overline{\text{OUT13}}$	O	Complementary Square Wave Clocking Output 13. This pin can be configured as one side of a differential LVPECL/LVDS/HSTL output or as a single-ended CMOS output.
26	OUT13	O	Square Wave Clocking Output 13. This pin can be configured as one side of a differential LVPECL/LVDS/HSTL output or as a single-ended CMOS output.
27	VDD3_OUT[12:13]	P	3.3 V Supply for Output 12 and Output 13 Clock Drivers.
28	$\overline{\text{OUT12}}$	O	Complementary Square Wave Clocking Output 12. This pin can be configured as one side of a differential LVPECL/LVDS/HSTL output or as a single-ended CMOS output.
29	OUT12	O	Square Wave Clocking Output 12. This pin can be configured as one side of a differential LVPECL/LVDS/HSTL output or as a single-ended CMOS output.
30	VDD1.8_OUT[12:13]	P	1.8 V Supply for Output 12 and Output 13 Clock Dividers.
31	$\overline{\text{OUT11}}$	O	Complementary Square Wave Clocking Output 11. This pin can be configured as one side of a differential LVPECL/LVDS/HSTL output or as a single-ended CMOS output.
32	OUT11	O	Square Wave Clocking Output 11. This pin can be configured as one side of a differential LVPECL/LVDS/HSTL output or as a single-ended CMOS output.
33	VDD3_OUT[10:11]	P	3.3 V Supply for Output 10 and Output 11 Clock Drivers.
34	$\overline{\text{OUT10}}$	O	Complementary Square Wave Clocking Output 10. This pin can be configured as one side of a differential LVPECL/LVDS/HSTL output or as a single-ended CMOS output.
35	OUT10	O	Square Wave Clocking Output 10. This pin can be configured as one side of a differential LVPECL/LVDS/HSTL output or as a single-ended CMOS output.
36	VDD1.8_OUT[10:11]	P	1.8 V Supply for Output 10 and Output 11 Clock Dividers.
37	$\overline{\text{OUT9}}$	O	Complementary Square Wave Clocking Output 9. This pin can be configured as one side of a differential LVPECL/LVDS/HSTL output or as a single-ended CMOS output.
38	OUT9	O	Square Wave Clocking Output 9. This pin can be configured as one side of a differential LVPECL/LVDS/HSTL output or as a single-ended CMOS output.
39	VDD3_OUT[8:9]	P	3.3 V Supply for Output 8 and Output 9 Clock Drivers.
40	$\overline{\text{OUT8}}$	O	Complementary Square Wave Clocking Output 8. This pin can be configured as one side of a differential LVPECL/LVDS/HSTL output or as a single-ended CMOS output.
41	OUT8	O	Square Wave Clocking Output 8. This pin can be configured as one side of a differential LVPECL/LVDS/HSTL output or as a single-ended CMOS output.
42	VDD1.8_OUT[8:9]	P	1.8 V Supply for Output 8 and Output 9 Clock Dividers.
43	$\overline{\text{OUT7}}$	O	Complementary Square Wave Clocking Output 7. This pin can be configured as one side of a differential LVPECL/LVDS/HSTL output or as a single-ended CMOS output.
44	OUT7	O	Square Wave Clocking Output 7. This pin can be configured as one side of a differential LVPECL/LVDS/HSTL output or as a single-ended CMOS output.

Pin No.	Mnemonic	Type ¹	Description
45	VDD3_OUT[6:7]	P	3.3 V Supply for Output 6 and Supply Output 7 Clock Drivers.
46	$\overline{\text{OUT6}}$	O	Complementary Square Wave Clocking Output 6. This pin can be configured as one side of a differential LVPECL/LVDS/HSTL output or as a single-ended CMOS output.
47	OUT6	O	Square Wave Clocking Output 6. This pin can be configured as one side of a differential LVPECL/LVDS/HSTL output or as a single-ended CMOS output.
48	VDD1.8_OUT[6:7]	P	1.8 V Supply for Output 6 and Output 7 Clock Dividers.
49	$\overline{\text{OUT5}}$	O	Complementary Square Wave Clocking Output 5. This pin can be configured as one side of a differential LVPECL/LVDS/HSTL output or as a single-ended CMOS output.
50	OUT5	O	Square Wave Clocking Output 5. This pin can be configured as one side of a differential LVPECL/LVDS/HSTL output or as a single-ended CMOS output.
51	VDD3_OUT[4:5]	P	3.3 V Supply for Output 4 and Output 5 Clock Drivers.
52	$\overline{\text{OUT4}}$	O	Complementary Square Wave Clocking Output 4. This pin can be configured as one side of a differential LVPECL/LVDS/HSTL output or as a single-ended CMOS output.
53	OUT4	O	Square Wave Clocking Output 4. This pin can be configured as one side of a differential LVPECL/LVDS/HSTL output or as a single-ended CMOS output.
54	VDD1.8_OUT[4:5]	P	1.8 V Supply for Output 4 and Output 5 Clock Dividers.
55	STATUS1/SP1	I/O	Lock Detect and Other Status Signals (STATUS1)/I ² C Address (SP1). This pin has an internal 40 k Ω pull-down resistor.
56	STATUS0/SP0	I/O	Lock Detect and Other Status Signals (STATUS0)/I ² C Address (SP0). This pin has an internal 40 k Ω pull-down resistor.
57	EEPROM_SEL	I	EEPROM Select. Setting this pin high selects the register values stored in the internal EEPROM to be loaded at reset and/or power-up. Setting this pin low causes the AD9523-1 to load the hard-coded default register values at power-up/reset. This pin has an internal 40 k Ω pull-down resistor.
58	$\overline{\text{OUT3}}$	O	Complementary Square Wave Clocking Output 3. This pin can be configured as one side of a differential LVPECL/LVDS/HSTL output or as a single-ended CMOS output.
59	OUT3	O	Square Wave Clocking Output 3. This pin can be configured as one side of a differential LVPECL/LVDS/HSTL output or as a single-ended CMOS output.
60	VDD3_OUT[2:3]	P	3.3 V Supply for Output 2 and Output 3 Clock Drivers.
61	$\overline{\text{OUT2}}$	O	Complementary Square Wave Clocking Output 2. This pin can be configured as one side of a differential LVPECL/LVDS/HSTL output or as a single-ended CMOS output.
62	OUT2	O	Square Wave Clocking Output 2. This pin can be configured as one side of a differential LVPECL/LVDS/HSTL output or as a single-ended CMOS output.
63	VDD1.8_OUT[2:3]	P	1.8 V Supply for Output 2 and Output 3 Clock Dividers.
64	$\overline{\text{OUT1}}$	O	Complementary Square Wave Clocking Output 1. This pin can be configured as one side of a differential LVPECL/LVDS/HSTL output or as a single-ended CMOS output.
65	OUT1	O	Square Wave Clocking Output 1. This pin can be configured as one side of a differential LVPECL/LVDS/HSTL output or as a single-ended CMOS output.
66	VDD3_OUT[0:1]	P	3.3 V Supply for Output 0 and Output 1 Clock Drivers.
67	$\overline{\text{OUT0}}$	O	Complementary Square Wave Clocking Output 0. This pin can be configured as one side of a differential LVPECL/LVDS/HSTL output or as a single-ended CMOS output.
68	OUT0	O	Square Wave Clocking Output 0. This pin can be configured as one side of a differential LVPECL/LVDS/HSTL output or as a single-ended CMOS output.
69	VDD1.8_OUT[0:1]	P	1.8 V Supply for Output 0 and Output 1 Clock Dividers.
70	ZD_IN	I	External Zero Delay Clock Input. Along with $\overline{\text{ZD_IN}}$, this pin is the differential input for the PLL reference. Alternatively, this pin can be programmed as a single-ended 3.3 V CMOS input.
71	$\overline{\text{ZD_IN}}$	I	Complementary External Zero Delay Clock Input. Along with ZD_IN, this pin is the differential input for the PLL reference. Alternatively, this pin can be programmed as a single-ended 3.3 V CMOS input.
72	PLL1_OUT	O	Single-Ended CMOS Output from PLL1. This pin has settings for weak and strong in Register 0x1BA, Bit 4 (see Table 52).
EP	EP, GND	GND	Exposed Paddle. The exposed paddle is the ground connection on the chip. It must be soldered to the analog ground of the PCB to ensure proper functionality and heat dissipation, noise, and mechanical strength benefits.

¹ P = power, I = input, O = output, I/O = input/output, P/O = power/output, GND = ground.

TYPICAL PERFORMANCE CHARACTERISTICS

$f_{VCO} = 122.88$ MHz, REFA differential at 30.72 MHz, $f_{VCO} = 2949.12$ MHz, and doubler is off, unless otherwise noted.

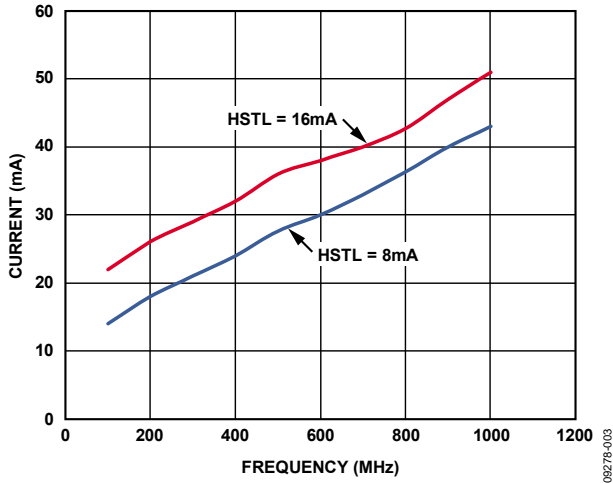

Figure 3. VDD3_OUT[x;y] Current (Typical) vs. Frequency; HSTL Mode at 16 mA and 8 mA

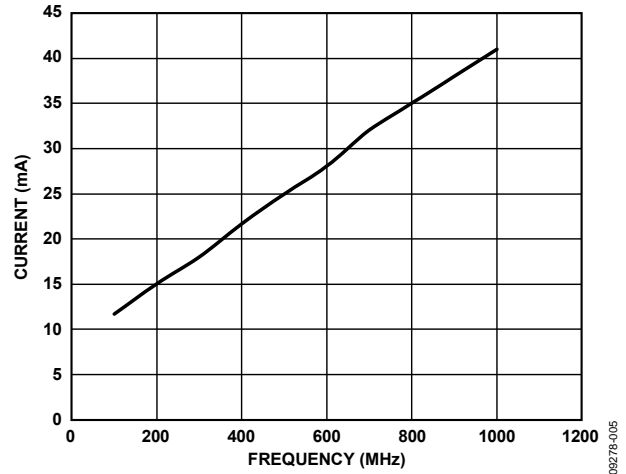

Figure 5. VDD3_OUT[x;y] Current (Typical) vs. Frequency, LVPECL Mode

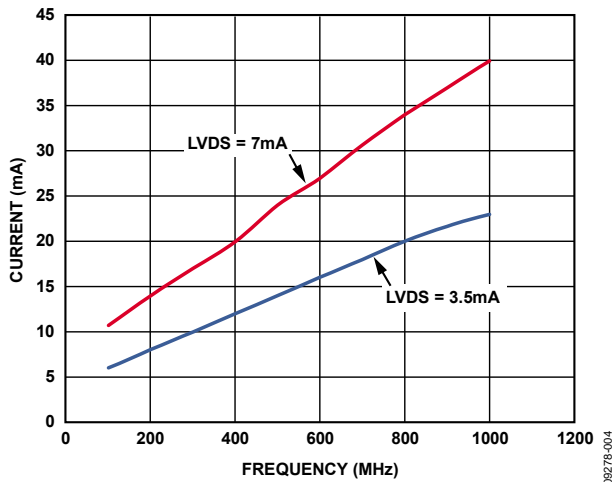

Figure 4. VDD3_OUT[x;y] Current (Typical) vs. Frequency; LVDS Mode at 7 mA and 3.5 mA

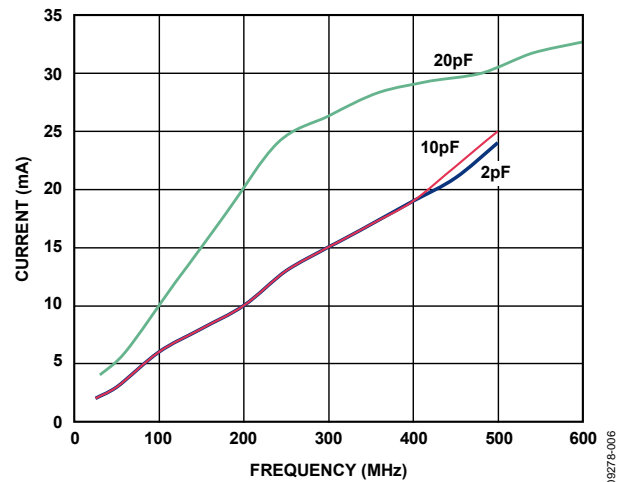

Figure 6. VDD3_OUT[x;y] Current (Typical) vs. Frequency; CMOS Mode at 20 pF, 10 pF, and 2 pF Load

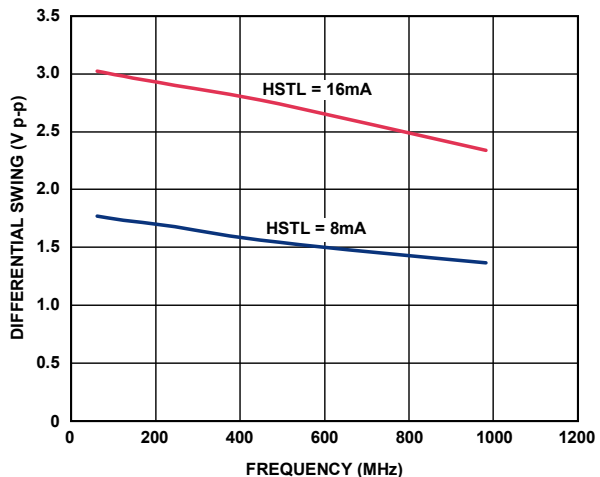

Figure 7. Differential Voltage Swing vs. Frequency; HSTL Mode at 16 mA and 8 mA

09278-007

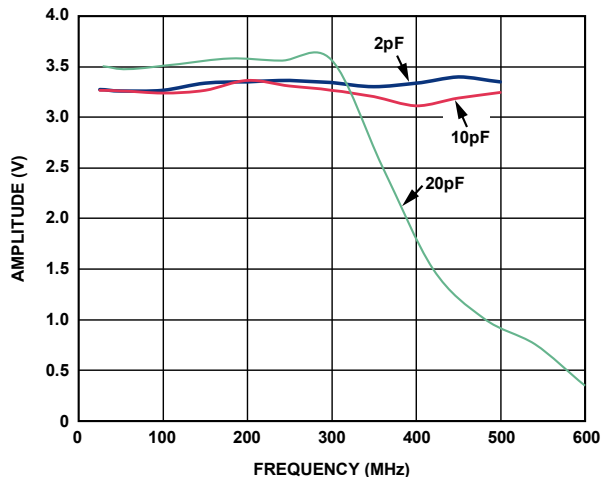

Figure 10. Amplitude vs. Frequency and Capacitive Load; CMOS Mode at 2 pF, 10 pF, and 20 pF Load

09278-010

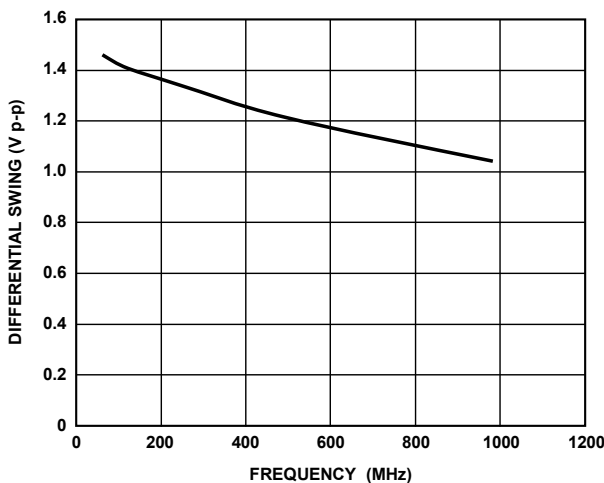

Figure 8. Differential Voltage Swing vs. Frequency, LVPECL Mode

09278-008

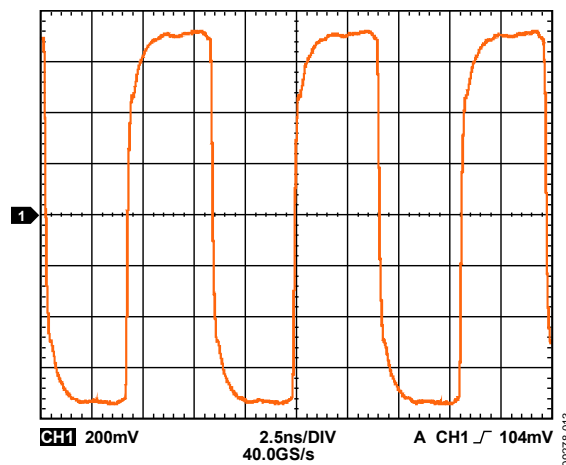

Figure 11. Output Waveform (Differential), LVPECL at 122.88 MHz

09278-013

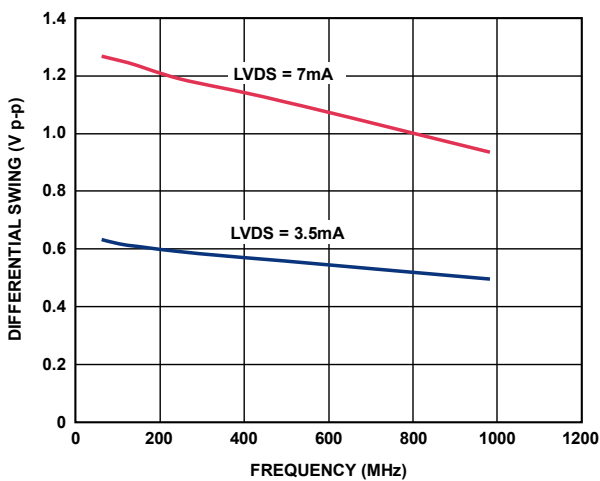

Figure 9. Differential Voltage Swing vs. Frequency; LVDS Mode at 7 mA and 3.5 mA

09278-009

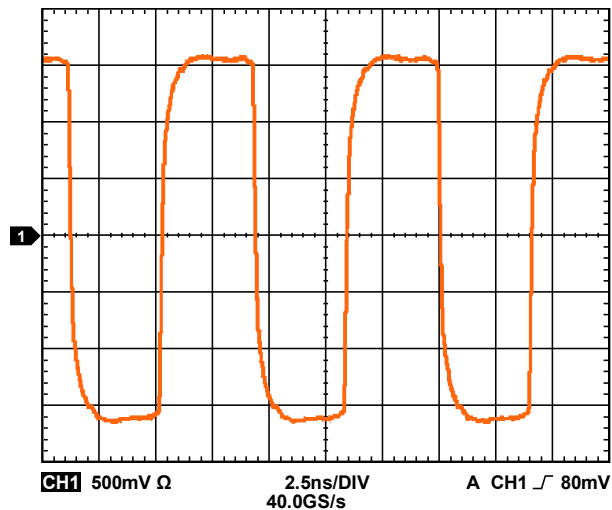

Figure 12. Output Waveform (Differential), HSTL at 16 mA, 122.88 MHz

09278-049

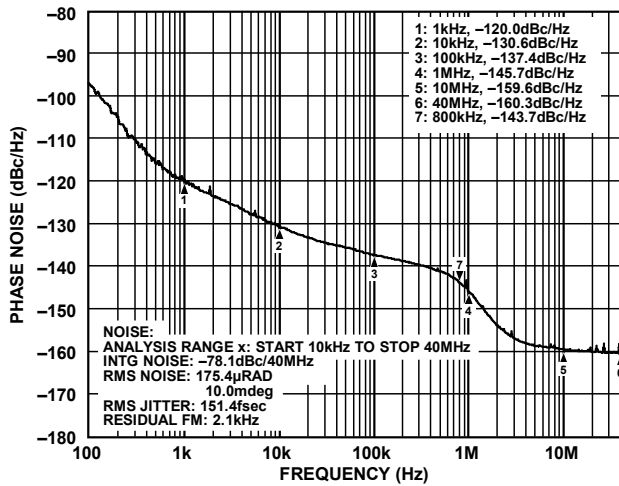

Figure 13. Phase Noise, Output = 184.32 MHz
(VCXO = 122.88 MHz, Crystek VCXO CVHD-950); Doubler On

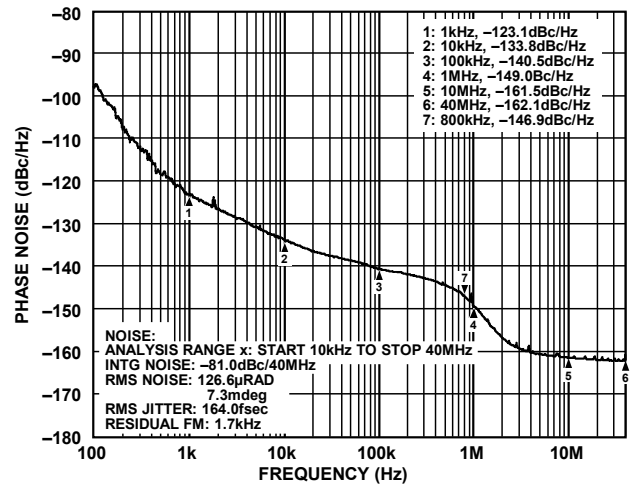

Figure 15. Phase Noise, Output = 122.88 MHz
(VCXO = 122.88 MHz, Crystek VCXO CVHD-950); Doubler On

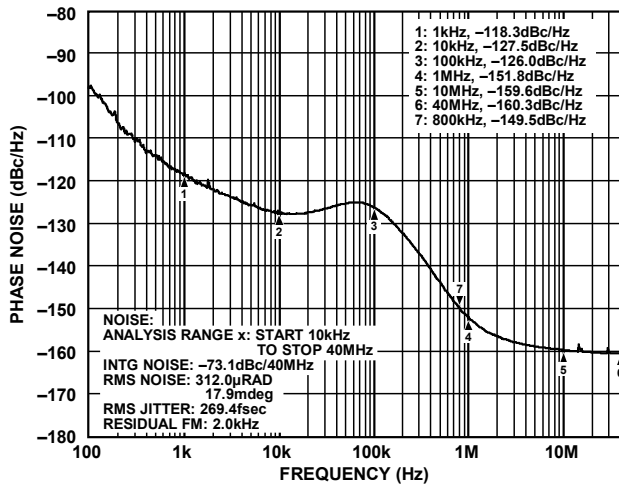

Figure 14. Phase Noise, Output = 184.32 MHz
(VCXO = 122.88 MHz, Crystek VCXO CVHD-950); Doubler On;
Optimized for Low 800 kHz Offset Noise

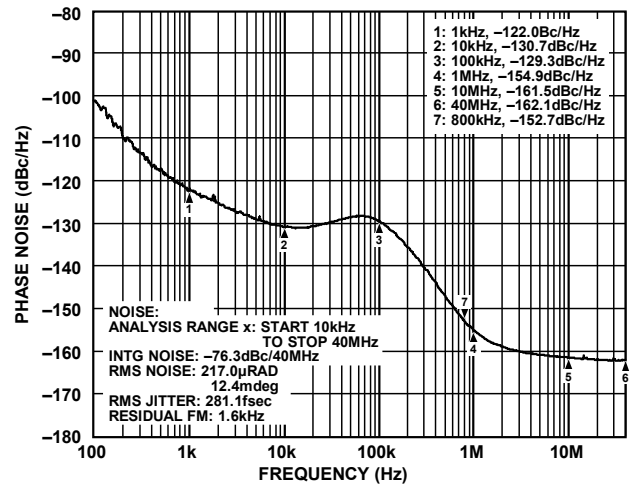

Figure 16. Phase Noise, Output = 122.88 MHz
(VCXO = 122.88 MHz, Crystek VCXO CVHD-950); Doubler On;
Optimized for Low 800 kHz Offset Noise

INPUT/OUTPUT TERMINATION RECOMMENDATIONS

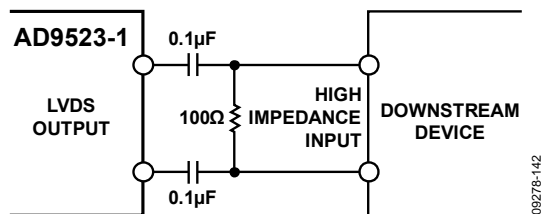

Figure 17. AC-Coupled LVDS Output Driver

09278-142

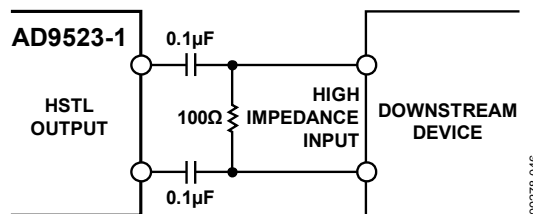

Figure 21. AC-Coupled HSTL Output Driver

09278-046

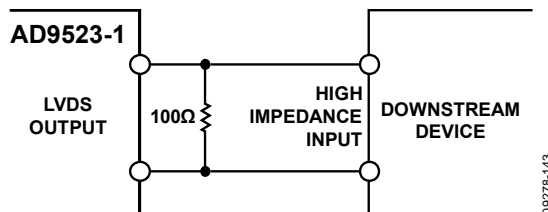

Figure 18. DC-Coupled LVDS Output Driver

09278-143

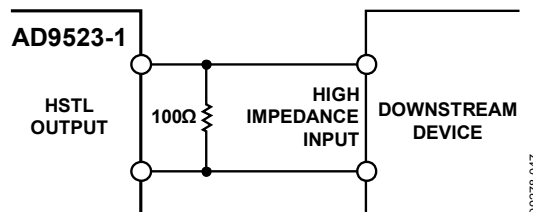

Figure 22. DC-Coupled HSTL Output Driver

09278-047

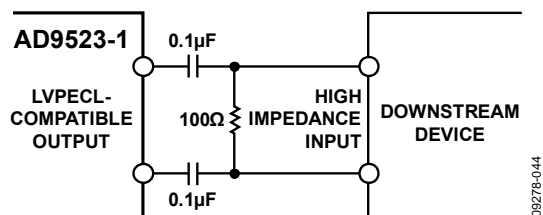
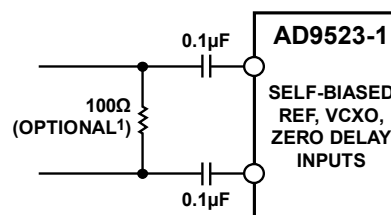

Figure 19. AC-Coupled LVPECL Output Driver

09278-044



¹RESISTOR VALUE DEPENDS UPON REQUIRED TERMINATION OF SOURCE.

Figure 23. REF_x, VCXO, and Zero Delay Input Differential Mode

09278-048

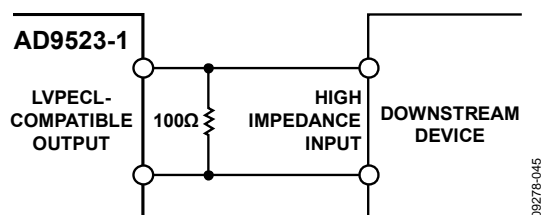

Figure 20. DC-Coupled LVPECL Output Driver

09278-045

TERMINOLOGY

Phase Jitter and Phase Noise

An ideal sine wave can be thought of as having a continuous and even progression of phase with time from 0° to 360° for each cycle. Actual signals, however, display a certain amount of variation from ideal phase progression over time. This phenomenon is called phase jitter. Although many causes can contribute to phase jitter, one major cause is random noise, which is characterized statistically as being Gaussian (normal) in distribution.

This phase jitter leads to a spreading out of the energy of the sine wave in the frequency domain, producing a continuous power spectrum. This power spectrum is usually reported as a series of values whose units are dBc/Hz at a given offset in frequency from the sine wave (carrier). The value is a ratio (expressed in decibels) of the power contained within a 1 Hz bandwidth with respect to the power at the carrier frequency. For each measurement, the offset from the carrier frequency is also given.

It is meaningful to integrate the total power contained within some interval of offset frequencies (for example, 10 kHz to 10 MHz). This is called the integrated phase noise over that frequency offset interval and can be readily related to the time jitter due to the phase noise within that offset frequency interval.

Phase noise has a detrimental effect on the performance of ADCs, DACs, and RF mixers. It lowers the achievable dynamic range of the converters and mixers, although they are affected in somewhat different ways.

Time Jitter

Phase noise is a frequency domain phenomenon. In the time domain, the same effect is exhibited as time jitter. When observing a sine wave, the time of successive zero crossings varies. In a square

wave, the time jitter is a displacement of the edges from their ideal (regular) times of occurrence. In both cases, the variations in timing from the ideal are the time jitter. Because these variations are random in nature, the time jitter is specified in seconds root mean square (rms) or 1 sigma of the Gaussian distribution.

Time jitter that occurs on a sampling clock for a DAC or an ADC decreases the signal-to-noise ratio (SNR) and dynamic range of the converter. A sampling clock with the lowest possible jitter provides the highest performance from a given converter.

Additive Phase Noise

Additive phase noise is the amount of phase noise that is attributable to the device or subsystem being measured. The phase noise of any external oscillators or clock sources is subtracted. This makes it possible to predict the degree to which the device impacts the total system phase noise when used in conjunction with the various oscillators and clock sources, each of which contributes its own phase noise to the total. In many cases, the phase noise of one element dominates the system phase noise. When there are multiple contributors to phase noise, the total is the square root of the sum of squares of the individual contributors.

Additive Time Jitter

Additive time jitter is the amount of time jitter that is attributable to the device or subsystem being measured. The time jitter of any external oscillators or clock sources is subtracted. This makes it possible to predict the degree to which the device impacts the total system time jitter when used in conjunction with the various oscillators and clock sources, each of which contributes its own time jitter to the total. In many cases, the time jitter of the external oscillators and clock sources dominates the system time jitter.

THEORY OF OPERATION

DETAILED BLOCK DIAGRAM

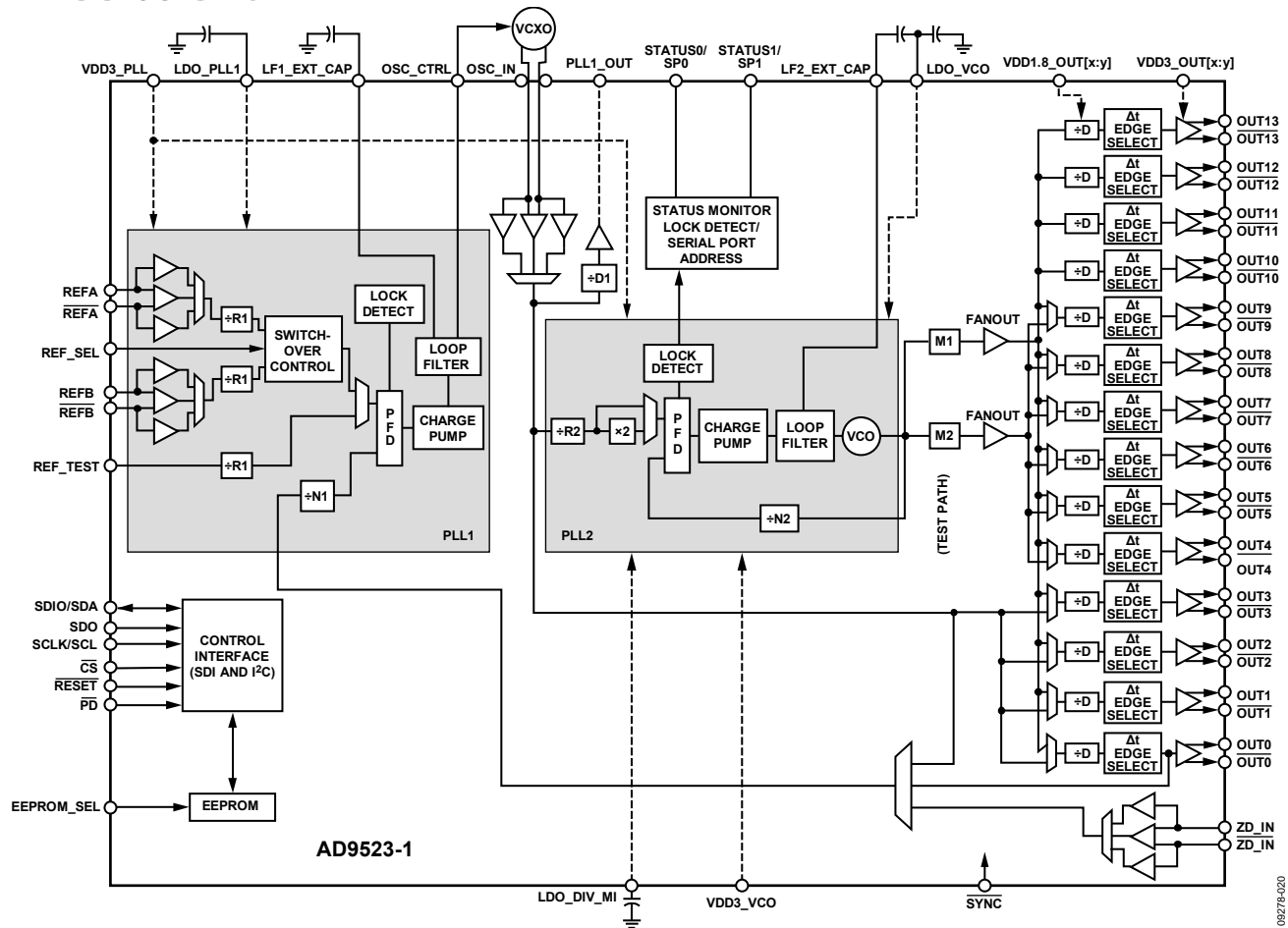

Figure 24. Top Level Diagram

OVERVIEW

The AD9523-1 is a clock generator that employs integer-N-based phase-locked loops (PLL). The device architecture consists of two cascaded PLL stages. The first stage, PLL1, consists of an integer division PLL that uses an external voltage-controlled crystal oscillator (VCXO) from 15 MHz to 250 MHz. PLL1 has a narrow-loop bandwidth that provides initial jitter cleanup of the input reference signal. The second stage, PLL2, is a frequency multiplying PLL that translates the first stage output frequency to a range of 2.94 GHz to 2.96 GHz. PLL2 incorporates an integer-based feedback divider that enables integer frequency multiplication. Programmable integer dividers (1 to 1024) follow PLL2, establishing a final output frequency of 1 GHz or less.

The AD9523-1 includes reference signal processing blocks that enable a smooth switching transition between two reference inputs. This circuitry automatically detects the presence of the reference input signals. If only one input is present, the device uses it as the active reference. If both are present, one becomes the active reference and the other becomes the backup reference. If the active reference fails, the circuitry automatically switches to the backup reference (if available), making it the new active reference.

A register setting determines what action to take if the failed reference is once again available: either stay on Reference B or revert to Reference A. If neither reference is usable, the AD9523-1 supports a holdover mode. A reference select pin (REF_SEL, Pin 16) is available to manually select which input reference is active (see Table 42). The accuracy of the holdover is dependent on the external VCXO frequency stability at half supply voltage.

Any of the divider settings are programmable via the serial programming port, enabling a wide range of input/output frequency ratios under program control. The dividers also include a programmable delay to adjust timing of the output signals, if required.

The output is compatible with LVPECL, LVDS, or HSTL logic levels (see the Input/Output Termination Recommendations section); however, the AD9523-1 is implemented only in CMOS.

The loop filters of each PLL are integrated and programmable. Only a single external capacitor for each of the two PLL loop filters is required.

The AD9523-1 operates over the extended industrial temperature range of -40°C to $+85^{\circ}\text{C}$.

COMPONENT BLOCKS—INPUT PLL (PLL1)

PLL1 General Description

Fundamentally, the input PLL (referred to as PLL1) consists of a phase-frequency detector (PFD), charge pump, passive loop filter, and an external VCXO operating in a closed loop (see Figure 26).

PLL1 has the flexibility to operate with a loop bandwidth of approximately 10 Hz to 100 Hz. This relatively narrow loop bandwidth gives the AD9523-1 the ability to suppress jitter that appears on the input references (REFA and REFB). The output of PLL1 then becomes a low jitter phase-locked version of the reference input system clock.

PLL1 Reference Clock Inputs

The AD9523-1 features two separate differential reference clock inputs, REFA and REFB. These inputs can be configured to operate in full differential mode or single-ended CMOS mode.

In differential mode, these pins are internally self-biased. If REFA or REFB is driven single-ended, the unused side (REFA, REFB) should be decoupled via a suitable capacitor to a quiet ground. Figure 23 shows the equivalent circuit of REFA or REFB. It is possible to dc-couple to these inputs, but the dc operation point should be set as specified in the Specifications tables.

To operate either the REFA input or the REFB input in 3.3 V CMOS mode, the user must set Bit 5 or Bit 6, respectively, in Register 0x01A (see Table 40). The single-ended inputs can be driven by either a dc-coupled CMOS level signal or an ac-coupled sine wave or square wave.

The differential reference input receiver is powered down when the differential reference input is not selected, or when the PLL is powered down. The single-ended buffers power down when the PLL is powered down, when their respective individual power-down registers are set, or when the differential receiver is selected.

The REFB R divider uses the same value as the REFA R divider unless Bit 7, the enable REFB R divider independent division control bit in Register 0x01C, is programmed as shown in Table 42.

PLL1 Loop Filter

The PLL1 loop filter requires the connection of an external capacitor from LF1_EXT_CAP (Pin 7) to ground. The value of the external capacitor depends on the use of an external VCXO and the configuration parameters, such as input clock rate and desired bandwidth. Normally, a 0.3 μF capacitor allows the loop bandwidth to range from 10 Hz to 100 Hz and ensures loop stability over the intended operating parameters of the device (see Table 43 for R_{ZERO} values).

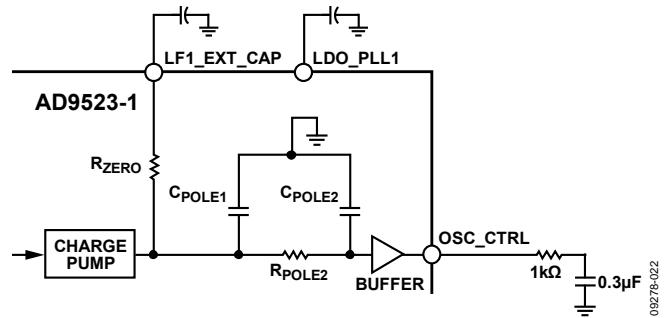

Figure 25. PLL1 Loop Filter

Table 19. PLL1 Loop Filter Programmable Values

R_{ZERO} (k Ω)	C_{POLE1} (nF)	R_{POLE2} (k Ω)	C_{POLE2} (nF)	LF1_EXT_CAP ¹ (μF)
883	1.5 fixed	165 fixed	0.337 fixed	0.3
677				
341				
135				
10				
External				

¹ External loop filter capacitor.

An external R-C low-pass filter should be used at the OSC_CTRL output. The values shown in Figure 25 add an additional low-pass pole at ~ 530 Hz. This R-C network filters the noise associated with the OSC_CTRL buffer to achieve the best noise performance at the 1 kHz offset region.

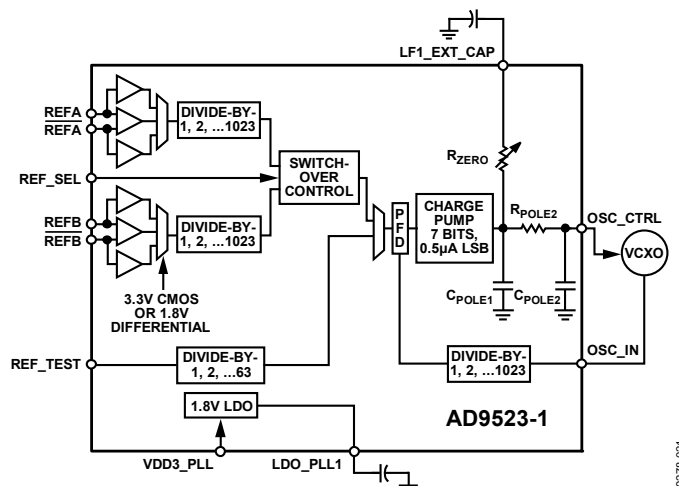

Figure 26. Input PLL (PLL1) Block Diagram

PLL1 Input Dividers

Each reference input feeds a dedicated reference divider block. The input dividers provide division of the reference frequency in integer steps from 1 to 1023. They provide the bulk of the frequency prescaling that is necessary to reduce the reference frequency to accommodate the bandwidth that is typically desired for PLL1.

PLL1 Reference Switchover

The reference monitor verifies the presence/absence of the prescaled REFA and REFB signals (that is, after division by the input dividers). The status of the reference monitor guides the activity of the switchover control logic. The AD9523-1 supports automatic and manual PLL reference clock switching between REFA (the REFA and REFA pins) and REFB (the REFB and REFB pins). This feature supports networking and infrastructure applications that require redundant references.

There are several configurable modes of reference switchover. The manual switchover is achieved either via a programming register setting or by using the REF_SEL pin. The automatic switchover occurs when REFA disappears and there is a reference on REFB.

The reference automatic switchover can be set to work as follows:

- Nonrevertive: stay on REFB. Switch from REFA to REFB when REFA disappears, but do not switch back to REFA if it reappears. If REFB disappears, then go back to REFA.
- Revert to REFA. Switch from REFA to REFB when REFA disappears. Return to REFA from REFB when REFA returns.

See Table 42 for the PLL1 miscellaneous control register bit settings.

PLL1 Holdover

In the absence of both input references, the device enters holdover mode. Holdover is a secondary function that is provided by PLL1. Because PLL1 has an external VCXO available as a frequency source, it continues to operate in the absence of the input reference signals. When the device switches to holdover,

the charge pump tristates. The device continues operating in this mode until a reference signal becomes available. Then the device exits holdover mode, and PLL1 resynchronizes with the active reference. In addition to tristate, the charge pump can be forced to VCC/2 during holdover (Register 0x01C, Bit 6; see Table 42).

COMPONENT BLOCKS—OUTPUT PLL (PLL2)

PLL2 General Description

The output PLL (referred to as PLL2) consists of an optional input reference doubler, reference divider, phase-frequency detector (PFD), a partially integrated analog loop filter (see Figure 27), an integrated voltage-controlled oscillator (VCO), and a feedback divider. The VCO produces a nominal 3.0 GHz signal with an output divider that is capable of division ratios of 3, 4, and 5.

The PFD of the output PLL drives a charge pump that increases, decreases, or holds constant the charge stored on the loop filter capacitors (both internal and external). The stored charge results in a voltage that sets the output frequency of the VCO. The feedback loop of the PLL causes the VCO control voltage to vary in a way that phase locks the PFD input signals.

The gain of PLL2 is proportional to the current delivered by the charge pump. The loop filter bandwidth is chosen to reduce noise contributions from PLL sources that could degrade phase noise requirements.

The output PLL has a VCO with multiple bands spanning a range of 2.94 GHz to 3.1 GHz. However, the actual operating frequency within a particular band depends on the control voltage that appears on the loop filter capacitor. The control voltage causes the VCO output frequency to vary linearly within the selected band. This frequency variability allows the control loop of the output PLL to synchronize the VCO output signal with the reference signal applied to the PFD. Typically, the device automatically selects the appropriate band as part of its calibration process (invoked via the VCO control register at Address 0x0F3, shown in Table 47).

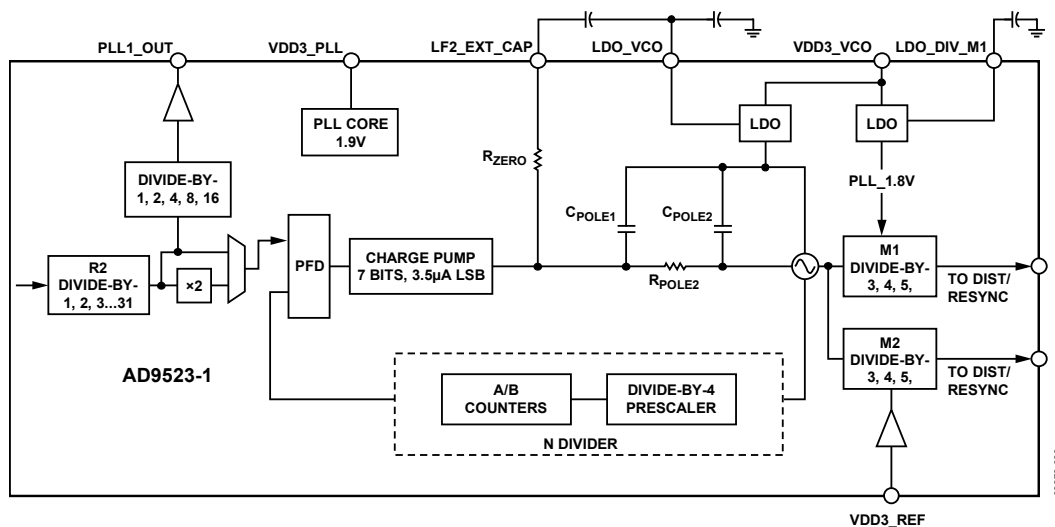

Figure 27. Output PLL (PLL2) Block Diagram

Input 2× Frequency Multiplier

The 2× frequency multiplier provides the option to double the frequency at the PLL2 input. This allows the user to take advantage of a higher frequency at the input to the PLL (PFD) and, thus, allows for reduced in-band phase noise and greater separation between the frequency generated by the PLL and the modulation spur associated with PFD. However, increased reference spur separation results in harmonic spurs, introduced by the frequency multiplier, that increase as the duty cycle deviates from 50% at the OSC_IN inputs. As such, beneficial use of the frequency multiplier is application-specific. Typically, a VCXO with proper interfacing has a duty cycle that is approximately 50% at the OSC_IN inputs. Note that the maximum output frequency of the 2× frequency multipliers must not exceed the maximum PFD rate that is specified in Table 11.

PLL2 Feedback Divider

PLL2 has a feedback divider (N divider) that enables it to provide integer frequency up-conversion. The PLL2 N divider is a combination of a prescaler (P) and two counters, A and B. The total divider value is

$$N = (P \times B) + A$$

where $P = 4$.

The feedback divider is a dual modulus prescaler architecture, with a nonprogrammable P that is equal to 4. The value of the B counter can be from 3 to 63, and the value of the A counter can be from 0 to 3. However, due to the architecture of the divider, there are constraints, as listed in Table 45.

PLL2 Loop Filter

The PLL2 loop filter requires the connection of an external capacitor from LF2_EXT_CAP (Pin 11) to LDO_VCO (Pin 12), as illustrated in Figure 27. The value of the external capacitor depends on the operating mode and the desired phase noise performance. For example, a loop bandwidth of approximately 500 kHz produces the lowest integrated jitter. A lower bandwidth produces lower phase noise at 1 MHz but increases the total integrated jitter.

Table 20. PLL2 Loop Filter Programmable Values

RZERO (Ω)	CPOLE1 (pF)	RPOLE2 (Ω)	CPOLE2 (pF)	LF2_EXT_CAP ¹ (pF)
3250	48	900	Fixed at 16	Typical at 1000
3000	40	450		
2750	32	300		
2500	24	225		
2250	16			
2100	8			
2000	0			
1850				

¹ External loop filter capacitor.

VCO Divider M1 and VCO Divider M2

The VCO dividers provide frequency division between the internal VCO and the clock distribution. Each VCO divider can be set to divide by 3, 4, or 5. When the AD9523-1 is used without any zero delay feedback (internal or external), the phase relationship between the reference inputs and the outputs is a function of the phase relationship between the OSC input and the reference inputs. Because the VCO divider is not reset by SYNC, there is an additional phase variability of up to x VCO periods, where $x = \text{VCO divider setting}$.

VCO Calibration

The AD9523-1 on-chip VCO must be manually calibrated to ensure proper operation over process and temperature. This is accomplished by setting the calibrate VCO bit (Register 0x0F3, Bit 1) to 1. (This bit is not self-clearing.) The setting can be performed as part of the initial setup before executing the IO_Update bit (Register 0x234, Bit 0 = 1). A readback bit, VCO calibration in progress (Register 0x22D, Bit 0), indicates when a VCO calibration is in progress by returning a logic true (that is, Bit 0 = 1). If the EEPROM is in use, setting the calibrate VCO bit to 1 before saving the register settings to the EEPROM ensures that the VCO calibrates automatically after the EEPROM has loaded. After calibration, it is recommended that a sync be initiated (see the Clock Distribution Synchronization section).

Note that the calibrate VCO bit defaults to 0. This bit must change from 0 to 1 to initiate a calibration sequence. Therefore, any subsequent calibrations require the following sequence:

1. Register 0x0F3, Bit 1 (calibrate VCO bit) = 0
2. Register 0x234, Bit 0 (IO_Update bit) = 1
3. Register 0x0F3, Bit 1 (calibrate VCO bit) = 1
4. Register 0x234, Bit 0 (IO_Update bit) = 1

VCO calibration is controlled by a calibration controller that runs off the VCXO input clock. The calibration requires that PLL2 be set up properly to lock the PLL2 loop and that the VCXO clock be present.

During power-up or reset, the distribution section is automatically held in sync until the first VCO calibration is finished. Therefore, no outputs can occur until VCO calibration is complete and PLL2 is locked.

Initiate a VCO calibration under the following conditions:

- After changing any of the PLL2 B counter and A counter settings or after a change in the PLL2 reference clock frequency. This means that a VCO calibration should be initiated any time that a PLL2 register or reference clock changes such that a different VCO frequency is the result.
- Whenever system calibration is desired. The VCO is designed to operate properly over extremes of temperature even when it is first calibrated at the opposite extreme. However, a VCO calibration can be initiated at any time, if desired.

CLOCK DISTRIBUTION

The clock distribution block provides an integrated solution for generating multiple clock outputs based on frequency dividing the PLL2 VCO divider output. OUT4 to OUT9 can use either VCO Divider M1 or VCO Divider M2, selectable via the register settings. The distribution output consists of 14 channels (OUT0 to OUT13). Each of the output channels has a dedicated divider and output driver, as shown in Figure 29. The AD9523-1 also has the capability to route the VCXO output to four of the outputs (OUT0 to OUT3).

Clock Dividers

The output clock distribution dividers are referred to as D0 to D13, corresponding to output channels OUT0 through OUT13, respectively. Each divider is programmable with 10 bits of division depth that is equal to 1 to 1024. Dividers have duty cycle correction to always give 50% duty cycle, even for odd divides.

Output Power-Down

Each of the output channels offers independent control of the power-down functionality via the Channel 0 to Channel 13 control registers (see Table 51). Each output channel has a dedicated power-down bit for powering down the output driver. However, if all 14 outputs are powered down, the entire distribution output enters a deep sleep mode. Although each channel has a channel power-down control signal, it may sometimes be desirable to power down an output driver while maintaining the divider's synchronization with the other channel dividers. This is accomplished by placing the output in tristate mode (this works in CMOS mode, as well).

Multimode Output Drivers

The user has independent control of the operating mode of each of the fourteen output channels via the Channel 0 to Channel 13 control registers (see Table 51). The operating mode control includes the following:

- Logic family and pin functionality
- Output drive strength
- Output polarity

The four least significant bits (LSBs) of each of the 14 Channel 0 to Channel 13 control registers comprise the driver mode bits. The mode value selects the desired logic family and pin functionality of an output channel, as listed in Table 51. This driver design allows a common 100 Ω external resistor for all the different driver modes of operation that are illustrated in Figure 28.

If the output channel is ac-coupled to the circuit to be clocked, changing the mode varies the voltage swing to determine sensitivity to the drive level. For example, in LVDS mode, a current of 3.5 mA causes a 350 mV peak voltage. Likewise, in LVPECL mode, a current of 8 mA causes an 800 mV peak voltage at the 100 Ω load resistor.

In addition to the four mode bits, each of the 14 Channel 0 to Channel 13 control registers includes the following control bits:

- Invert divider output. Enables the user to choose between normal polarity and inverted polarity. Normal polarity is the default state. Inverted polarity reverses the representation of Logic 0 and Logic 1, regardless of the logic family.
- Ignore sync. Makes the divider ignore the SYNC signal from any source.
- Power down channel. Powers down the entire channel.
- Lower power mode.
- Driver mode.
- Channel divider.
- Divider phase.

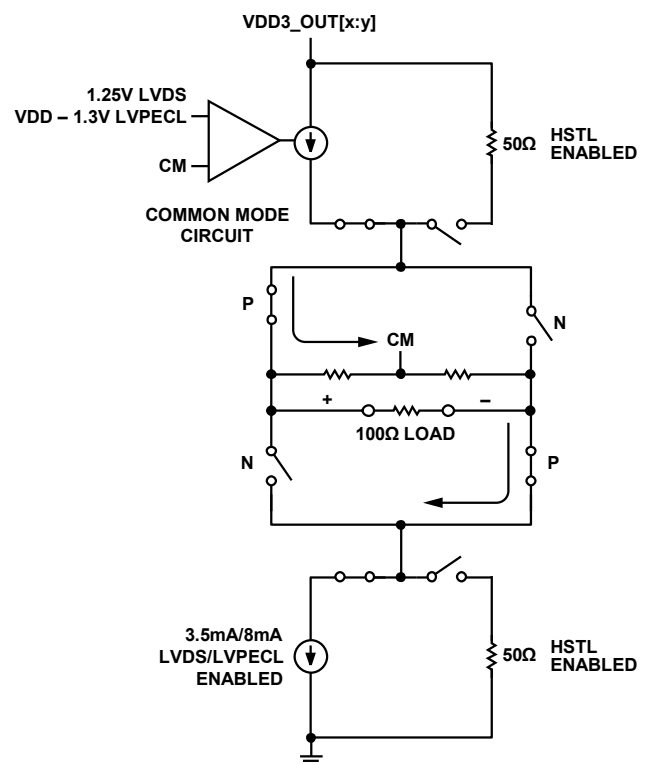

Figure 28. Multimode Driver

08278-031

Clock Distribution Synchronization

A block diagram of the clock distribution synchronization functionality is shown in Figure 29. The synchronization sequence begins with the primary synchronization signal, which ultimately results in delivery of a synchronization strobe to the clock distribution logic.

As indicated, the primary synchronization signal originates from one of the following sources:

- Direct synchronization source via the sync dividers bit (see Table 55, Register 0x232, Bit 0)
- Device pin, SYNC (Pin 17)

An automatic synchronization of the divider is initiated the first time that PLL2 locks after a power-up or reset event. Subsequent lock/unlock events do not initiate a resynchronization of the distribution dividers unless they are preceded by a power-down or reset of the part.

Both sources of the primary synchronization signal are logic OR'd; therefore, any one of them can synchronize the clock distribution output at any time. When using the sync dividers bit, the user

first sets and then clears the bit. The synchronization event is the clearing operation (that is, the Logic 1 to Logic 0 transition of the bit). The dividers are all automatically synchronized to each other when PLL2 is ready. The dividers support programmable phase offsets from 0 to 63 steps, in half periods of the input clock (for example, the VCO divider output clock). The phase offsets are incorporated into the dividers through a preset for the first output clock period of each divider. Phase offsets are supported only by programming the initial phase and divide value and then issuing a sync to the distribution (automatically at startup or manually, if desired).

In normal operation, the phase offsets are already programmed through the EEPROM or the SPI/I²C port before the AD9523-1 starts to provide outputs. Although the user cannot adjust the phase offsets while the dividers are operating, it is possible to adjust the phase of all the outputs together without powering down PLL1 and PLL2. This is accomplished by programming the new phase offset, using Bits[7:2] in Register 0x192 (see Table 51) and then issuing a divide sync signal by using the SYNC pin or the sync dividers bit (Register 0x232, Bit 0).

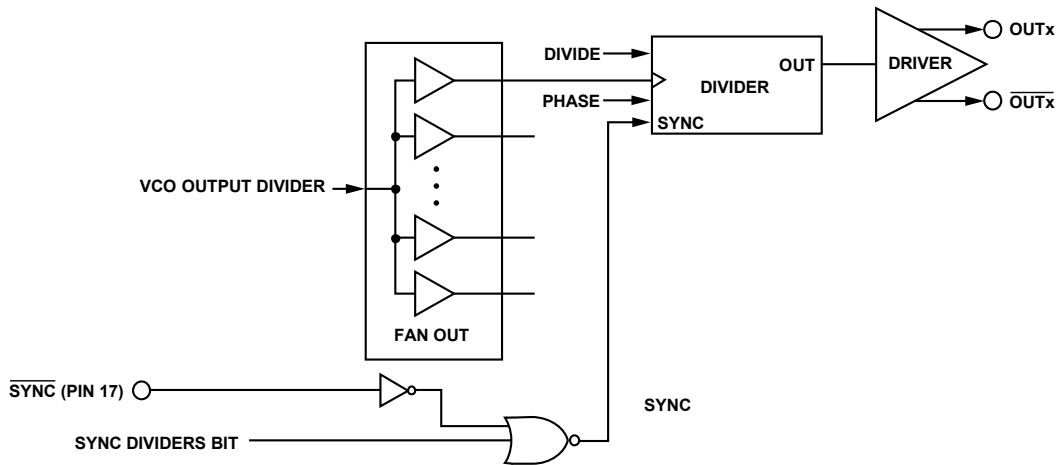

Figure 29. Clock Distribution Synchronization Block Diagram

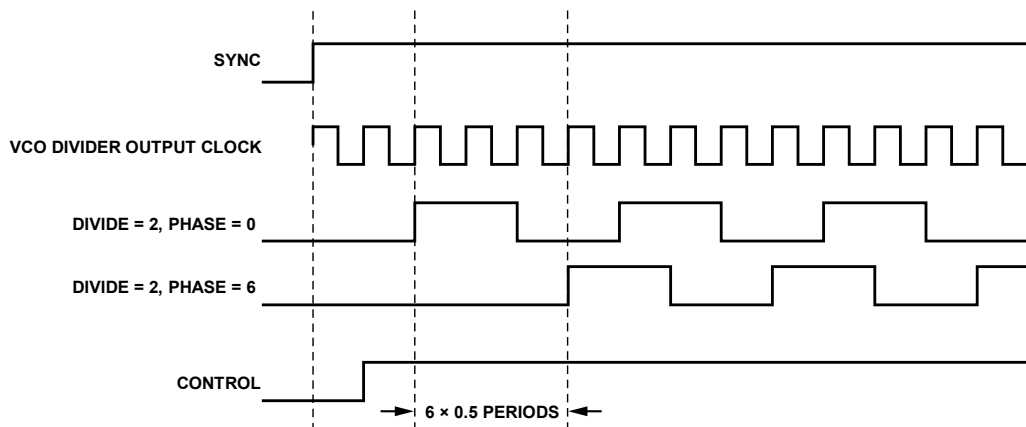

Figure 30. Clock Output Synchronization Timing Diagram

All outputs that are not programmed to ignore the sync are disabled temporarily while the sync is active. Note that, if an output is used for the zero delay path, it also disappears momentarily. However, this is desirable because it ensures that all the synchronized outputs have a deterministic phase relationship with respect to the zero delay output and, therefore, also with respect to the input.

ZERO DELAY OPERATION

Zero delay operation aligns the phase of the output clocks with the phase of the external PLL reference input. The OUT0 output is designed to be used as the output for zero delay. There are two zero delay modes on the AD9523-1: internal and external (see Figure 31). Note that the external delay mode provides better matching than the internal delay mode because the output drivers are included in the zero delay path. Setting the antitbacklash pulse width control of PLL1 to maximum gives the best zero delay matching.

Internal Zero Delay Mode

The internal zero delay function of the AD9523-1 is achieved by feeding the output of Channel Divider 0 back to the PLL1 N divider. Bit 5 in Register 0x01B is used to select internal zero delay mode (see Table 41). In the internal zero delay mode, the output

of Channel Divider 0 is routed back to the PLL1 (N divider) through a mux. PLL1 synchronizes the phase/edge of the output of Channel Divider 0 with the phase/edge of the reference input.

Because the channel dividers are synchronized to each other, the outputs of the channel divider are synchronous with the reference input.

External Zero Delay Mode

The external zero delay function of the AD9523-1 is achieved by feeding OUT0 back to the ZD_IN input and, ultimately, back to the PLL1 N divider. In Figure 31, the change in signal routing for external zero delay is external to the AD9523-1.

Bit 5 in Register 0x01B is used to select the external zero delay mode. In external zero delay mode, OUT0 must be routed back to PLL1 (the N divider) through the ZD_IN and $\overline{ZD_IN}$ pins.

PLL1 synchronizes the phase/edge of the feedback output clock with the phase/edge of the reference input. Because the channel dividers are synchronized to each other, the clock outputs are synchronous with the reference input. Both the reference path delay and the feedback delay from ZD_IN are designed to have the same propagation delay from the output drivers and PLL components to minimize the phase offset between the clock output and the reference input to achieve zero delay.

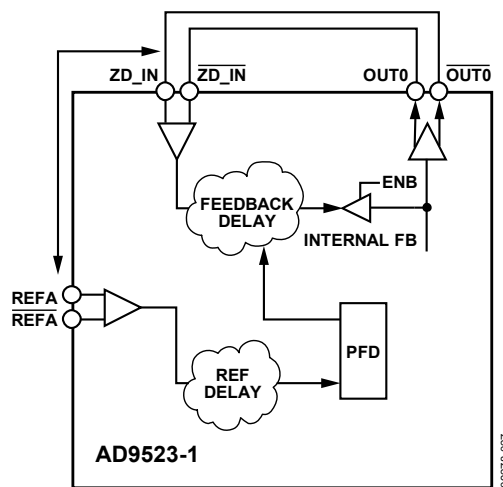

Figure 31. Zero Delay Function

SERIAL CONTROL PORT

The AD9523-1 serial control port is a flexible, synchronous serial communications port that allows an easy interface with many industry-standard microcontrollers and microprocessors. The AD9523-1 serial control port is compatible with most synchronous transfer formats, including Philips I²C®, Motorola® SPI, and Intel® SSR protocols. The AD9523-1 I²C implementation deviates from the classic I²C specification in two specifications, and these deviations are documented in Table 15 of this data sheet. The serial control port allows read/write access to all registers that configure the AD9523-1.

SPI/I²C PORT SELECTION

The AD9523-1 has two serial interfaces, SPI and I²C. Users can select either the SPI or I²C, depending on the states (logic high, logic low) of the two logic level input pins, SP1 and SP0, when power is applied or after a **RESET** (each pin has an internal 40 kΩ pull-down resistor). When both SP1 and SP0 are low, the SPI interface is active. Otherwise, I²C is active with three different I²C slave address settings (seven bits wide), as shown in Table 21. The five MSBs of the slave address are hardware coded as 11000, and the two LSBs are determined by the logic levels of the SP1 and SP0 pins.

Table 21. Serial Port Mode Selection

SP1	SP0	Address
Low	Low	SPI
Low	High	I ² C: 1100000
High	Low	I ² C: 1100001
High	High	I ² C: 1100010

I²C SERIAL PORT OPERATION

The AD9523-1 I²C port is based on the I²C fast mode standard. The AD9523-1 supports both I²C protocols: standard mode (100 kHz) and fast mode (400 kHz).

The AD9523-1 I²C port has a 2-wire interface consisting of a serial data line (SDA) and a serial clock line (SCL). In an I²C bus system, the AD9523-1 is connected to the serial bus (data bus SDA and clock bus SCL) as a slave device, meaning that no clock is generated by the AD9523-1. The AD9523-1 uses direct 16-bit (two bytes) memory addressing instead of traditional 8-bit (one byte) memory addressing.

I²C Bus Characteristics

Table 22. I²C Bus Definitions

Abbreviation	Definition
S	Start
Sr	Repeated start
P	Stop
A	Acknowledge
\bar{A}	No acknowledge
W	Write
R	Read

One pulse on the SCL clock line is generated for each data bit that is transferred.

The data on the SDA line must not change during the high period of the clock. The state of the data line can change only when the clock on the SCL line is low.

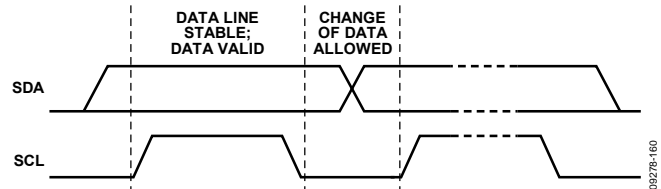

Figure 32. Valid Bit Transfer

A start condition is a transition from high to low on the SDA line while SCL is high. The start condition is always generated by the master to initialize the data transfer.

A stop condition is a transition from low to high on the SDA line while SCL is high. The stop condition is always generated by the master to end the data transfer.

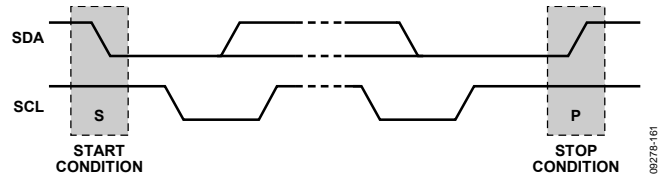

Figure 33. Start and Stop Conditions

A byte on the SDA line is always eight bits long. An acknowledge bit must follow every byte. Bytes are sent MSB first.

The acknowledge bit is the ninth bit attached to any 8-bit data byte (see Figure 34). An acknowledge bit is always generated by the receiving device (receiver) to inform the transmitter that the byte has been received. It is accomplished by pulling the SDA line low during the ninth clock pulse after each 8-bit data byte.

The no acknowledge bit is the ninth bit attached to any 8-bit data byte. A no acknowledge bit is always generated by the receiving device (receiver) to inform the transmitter that the byte has not been received. It is accomplished by leaving the SDA line high during the ninth clock pulse after each 8-bit data byte.

Data Transfer Process

The master initiates data transfer by asserting a start condition. This indicates that a data stream follows. All I²C slave devices connected to the serial bus respond to the start condition.

The master then sends an 8-bit address byte over the SDA line, consisting of a 7-bit slave address (MSB first), plus an R/W bit. This bit determines the direction of the data transfer, that is, whether data is written to or read from the slave device (0 = write, 1 = read).

The peripheral whose address corresponds to the transmitted address responds by sending an acknowledge bit. All other devices on the bus remain idle while the selected device waits for data to be read from or written to it. If the R/W bit is 0, the master (transmitter) writes to the slave device (receiver). If the R/W bit is 1, the master (receiver) reads from the slave device (transmitter). The format for these commands is described in the Data Transfer Format section.

Data is then sent over the serial bus in the format of nine clock pulses, one data byte (eight bits) from either master (write mode) or slave (read mode), followed by an acknowledge bit from the receiving device. The number of bytes that can be transmitted per transfer is unrestricted. In write mode, the first two data bytes immediately after the slave address byte are the internal memory (control registers) address bytes with the high address byte first. This addressing scheme gives a memory address of up to $2^{16} - 1 = 65,535$. The data bytes after these two memory address bytes are register data written into the control registers. In read mode, the data bytes after the slave address byte are register data read from the control registers. A single I²C transfer can contain multiple data bytes that can be read from or written to control registers whose address is automatically incremented starting from the base memory address.

When all data bytes are read or written, stop conditions are established. In write mode, the master (transmitter) asserts a stop condition to end data transfer during the 10th clock pulse following the acknowledge bit for the last data byte from the slave device (receiver). In read mode, the master device (receiver) receives the last data byte from the slave device (transmitter) but does not pull it low during the ninth clock pulse. This is known as a no acknowledge bit. Upon receiving the no acknowledge bit, the slave device knows that the data transfer is finished and releases the SDA line. The master then takes the data line low during the low period before the 10th clock pulse and high during the 10th clock pulse to assert a stop condition.

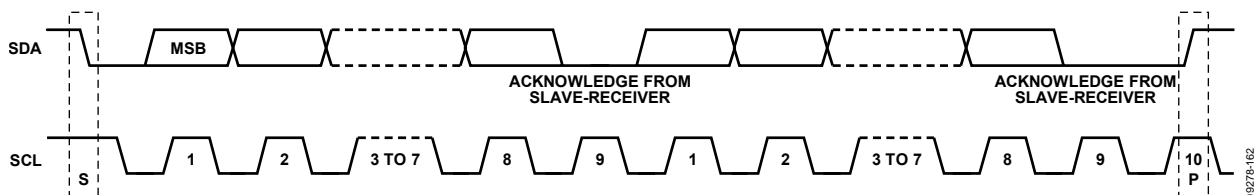

Figure 34. Acknowledge Bit

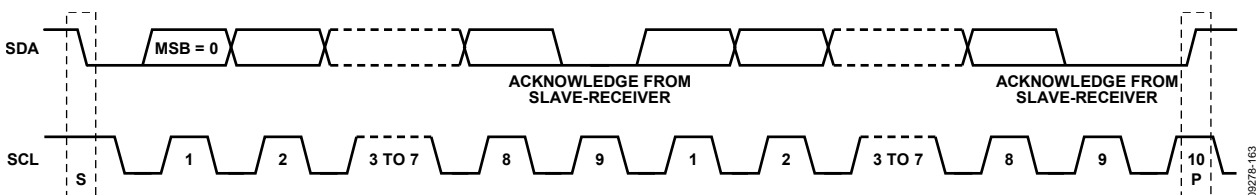

Figure 35. Data Transfer Process (Master Write Mode, 2-Byte Transfer Used for Illustration)

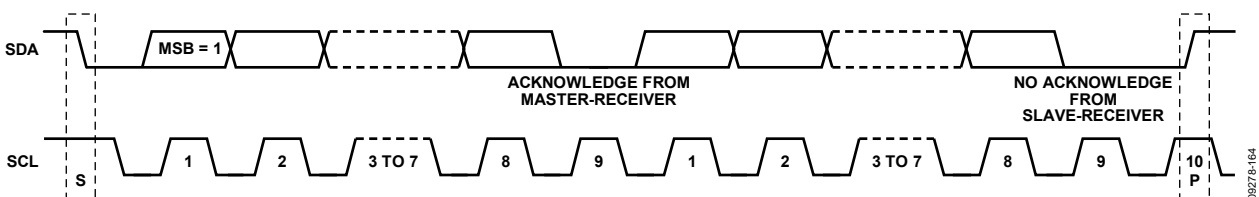

Figure 36. Data Transfer Process (Master Read Mode, 2-Byte Transfer Used for Illustration)

AD9523-1

A repeated start (Sr) condition can be used in place of a stop condition. Furthermore, a start or stop condition can occur at any time; partially transferred bytes are discarded.

For an I²C data write transfer containing multiple data bytes, the peripheral drives a no acknowledge for the data byte that

follows a write to Register 0x234, thereby ending the I²C transfer. For an I²C data read transfer containing multiple data bytes, the peripheral drives data bytes of 0x00 for subsequent reads that follow a read from Register 0x234.

Data Transfer Format

Send byte format. The send byte protocol is used to set up the register address for subsequent commands.

S	Slave Address	W	A	RAM Address High Byte	A	RAM Address Low Byte	A	P
---	---------------	---	---	-----------------------	---	----------------------	---	---

Write byte format. The write byte protocol is used to write a register address to the RAM, starting from the specified RAM address.

S	Slave Address	W	A	RAM Address High Byte	A	RAM Address Low Byte	A	RAM Data 0	A	RAM Data 1	A	RAM Data 2	A	P
---	---------------	---	---	-----------------------	---	----------------------	---	------------	---	------------	---	------------	---	---

Receive byte format. The receive byte protocol is used to read the data byte(s) from the RAM, starting from the current address.

S	Slave Address	R	A	RAM Data 0	A	RAM Data 1	A	RAM Data 2	\bar{A}	P
---	---------------	---	---	------------	---	------------	---	------------	-----------	---

Read byte format. The combined format of the send byte and the receive byte.

S	Slave Address	W	A	RAM Address High Byte	A	RAM Address Low Byte	A	Sr	Slave Address	R	A	RAM Data 0	A	RAM Data 1	A	RAM Data 2	\bar{A}	P
---	---------------	---	---	-----------------------	---	----------------------	---	----	---------------	---	---	------------	---	------------	---	------------	-----------	---

I²C Serial Port Timing

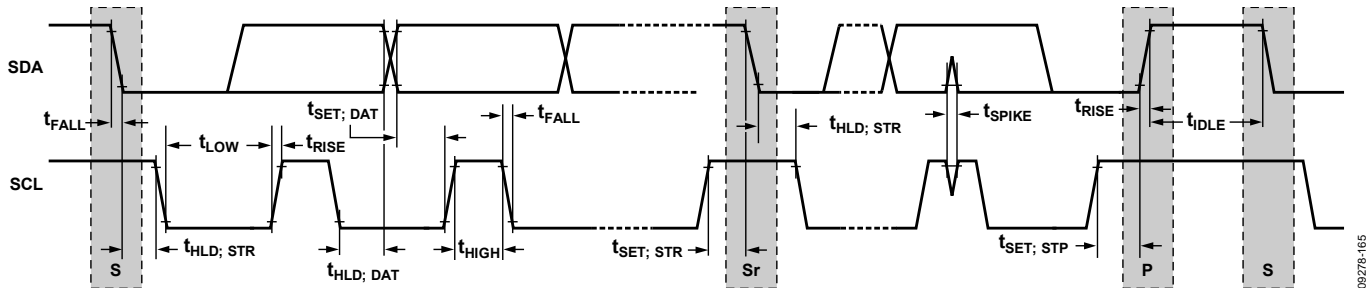

Figure 37. I²C Serial Port Timing

Table 23. I²C Timing Definitions

Parameter	Description
f _{I2C}	I ² C clock frequency
t _{IDLE}	Bus idle time between stop and start conditions
t _{HLD; STR}	Hold time for repeated start condition
t _{SET; STR}	Setup time for repeated start condition
t _{SET; STP}	Setup time for stop condition
t _{HLD; DAT}	Hold time for data
t _{SET; DAT}	Setup time for data
t _{LOW}	Duration of SCL clock low
t _{HIGH}	Duration of SCL clock high
t _{RISE}	SCL/SDA rise time
t _{FALL}	SCL/SDA fall time
t _{SPIKE}	Voltage spike pulse width that must be suppressed by the input filter

SPI SERIAL PORT OPERATION

Pin Descriptions

SCLK (serial clock) is the serial shift clock. This pin is an input. SCLK is used to synchronize serial control port reads and writes. Write data bits are registered on the rising edge of this clock, and read data bits are registered on the falling edge. This pin is internally pulled down by a 40 k Ω resistor to ground.

SDIO (serial data input/output) is a dual-purpose pin and acts either as an input only (unidirectional mode) or as an input/output (bidirectional mode). The AD9523-1 defaults to the bidirectional I/O mode.

SDO (serial data out) is used only in the unidirectional I/O mode as a separate output pin for reading back data. SDO is always active; therefore, the unidirectional I/O mode should not be used in a multislave environment.

$\overline{\text{CS}}$ (chip select bar) is an active low control that gates the read and write cycles. When $\overline{\text{CS}}$ is high, SDIO is in a high impedance state. This pin is internally pulled up by a 40 k Ω resistor to VDD3_REF.

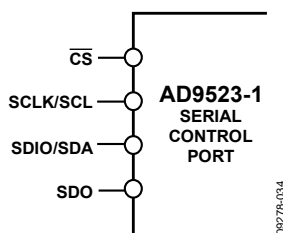

Figure 38. Serial Control Port

SPI Mode Operation

In SPI mode, single or multiple byte transfers are supported, as well as MSB first or LSB first transfer formats. The AD9523-1 serial control port can be configured for a single bidirectional I/O pin (SDIO only) or for two unidirectional I/O pins (SDIO/SDO). By default, the AD9523-1 is in bidirectional mode. Short instruction mode (8-bit instructions) is not supported. Only long (16-bit) instruction mode is supported.

A write or a read operation to the AD9523-1 is initiated by pulling $\overline{\text{CS}}$ low.

The $\overline{\text{CS}}$ stalled high mode is supported in data transfers where three or fewer bytes of data (plus instruction data) are transferred (see Table 24). In this mode, the $\overline{\text{CS}}$ pin can temporarily return high on any byte boundary, allowing time for the system controller to process the next byte. $\overline{\text{CS}}$ can go high only on byte boundaries; however, it can go high during either phase (instruction or data) of the transfer.

During this period, the serial control port state machine enters a wait state until all data is sent. If the system controller decides to abort the transfer before all of the data is sent, the state machine must be reset either by completing the remaining transfers or by returning $\overline{\text{CS}}$ low for at least one complete SCLK cycle (but fewer

than eight SCLK cycles). Raising the $\overline{\text{CS}}$ pin on a nonbyte boundary terminates the serial transfer and flushes the buffer.

In streaming mode (see Table 24), any number of data bytes can be transferred in a continuous stream. The register address is automatically incremented or decremented (see the SPI MSB/LSB First Transfers section). $\overline{\text{CS}}$ must be raised at the end of the last byte to be transferred, thereby ending streaming mode.

Communication Cycle—Instruction Plus Data

There are two parts to a communication cycle with the AD9523-1. The first part writes a 16-bit instruction word into the AD9523-1, coincident with the first 16 SCLK rising edges. The instruction word provides the AD9523-1 serial control port with information regarding the data transfer, which is the second part of the communication cycle. The instruction word defines whether the upcoming data transfer is a read or a write, the number of bytes in the data transfer, and the starting register address for the first byte of the data transfer.

Write

If the instruction word is for a write operation, the second part is the transfer of data into the serial control port buffer of the AD9523-1. Data bits are registered on the rising edge of SCLK.

The length of the transfer (one, two, or three bytes or streaming mode) is indicated by two bits (W1, W0) in the instruction byte. When the transfer is one, two, or three bytes but not streaming, $\overline{\text{CS}}$ can be raised after each sequence of eight bits to stall the bus (except after the last byte, where it ends the cycle). When the bus is stalled, the serial transfer resumes when $\overline{\text{CS}}$ is lowered. Raising the $\overline{\text{CS}}$ pin on a nonbyte boundary resets the serial control port. During a write, streaming mode does not skip over reserved or blank registers, and the user can write 0x00 to the reserved register addresses.

Because data is written into a serial control port buffer area, and not directly into the actual control registers of the AD9523-1, an additional operation is needed to transfer the serial control port buffer contents to the actual control registers of the AD9523-1, thereby causing them to become active. The update registers operation consists of setting the self-clearing IO_Update bit, Bit 0 of Register 0x234 (see Table 57). Any number of data bytes can be changed before executing an update registers operation. The update registers simultaneously actuates all register changes that have been written to the buffer since any previous update.

Read

The AD9523-1 supports only the long instruction mode. If the instruction word is for a read operation, the next $N \times 8$ SCLK cycles clock out the data from the address specified in the instruction word, where N is 1 to 3 as determined by Bits[W1:W0]. If $N = 4$, the read operation is in streaming mode, continuing until $\overline{\text{CS}}$ is raised. Streaming mode does not skip over reserved or blank registers. The readback data is valid on the falling edge of SCLK.

AD9523-1

The default mode of the AD9523-1 serial control port is the bidirectional mode. In bidirectional mode, both the sent data and the readback data appear on the SDIO pin. It is also possible to set the AD9523-1 to unidirectional mode. In unidirectional mode, the readback data appears on the SDO pin.

A readback request reads the data that is in the serial control port buffer area or the data that is in the active registers (see Figure 39).

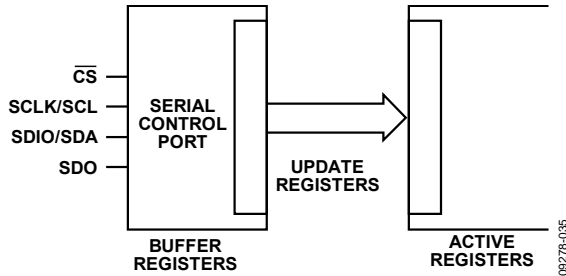

Figure 39. Relationship Between Serial Control Port Buffer Registers and Active Registers

SPI INSTRUCTION WORD (16 BITS)

The MSB of the instruction word is R/\overline{W} , which indicates whether the instruction is a read or a write. The next two bits ([W1:W0]) indicate the length of the transfer in bytes. The final 13 bits are the address ([A12:A0]) at which to begin the read or write operation.

For a write, the instruction word is followed by the number of bytes of data indicated by Bits[W1:W0] (see Table 24).

Table 24. Byte Transfer Count

W1	W0	Bytes to Transfer
0	0	1
0	1	2
1	0	3
1	1	Streaming mode

Bits[A12:A0] select the address within the register map that is written to or read from during the data transfer portion of the communications cycle. Only Bits[A11:A0] are needed to cover the range of the 0x234 registers used by the AD9523-1. Bit A12 must always be 0. For multibyte transfers, this address is the starting byte address. In MSB first mode, subsequent bytes decrement the address.

Table 26. Serial Control Port, 16-Bit Instruction Word, MSB First

MSB															LSB
I15	I14	I13	I12	I11	I10	I9	I8	I7	I6	I5	I4	I3	I2	I1	I0
R/ \overline{W}	W1	W0	A12 = 0	A11	A10	A9	A8	A7	A6	A5	A4	A3	A2	A1	A0

SPI MSB/LSB FIRST TRANSFERS

The AD9523-1 instruction word and byte data can be MSB first or LSB first. Any data written to Register 0x000 must be mirrored: Bit 7 is mirrored to Bit 0, Bit 6 to Bit 1, Bit 5 to Bit 2, and Bit 4 to Bit 3. This makes it irrelevant whether LSB first or MSB first is in effect. The default for the AD9523-1 is MSB first.

When LSB first is set by Register 0x000, Bit 1, and Register 0x000, Bit 6, it takes effect immediately because it affects only the operation of the serial control port and does not require that an update be executed.

When MSB first mode is active, the instruction and data bytes must be written from MSB to LSB. Multibyte data transfers in MSB first format start with an instruction byte that includes the register address of the most significant data byte. Subsequent data bytes must follow in order from the high address to the low address. In MSB first mode, the serial control port internal address generator decrements for each data byte of the multibyte transfer cycle.

When LSB first mode is active, the instruction and data bytes must be written from LSB to MSB. Multibyte data transfers in LSB first format start with an instruction byte that includes the register address of the least significant data byte, followed by multiple data bytes. In a multibyte transfer cycle, the internal byte address generator of the serial port increments for each byte.

The AD9523-1 serial control port register address decrements from the register address just written toward 0x000 for multibyte I/O operations if the MSB first mode is active (default). If the LSB first mode is active, the register address of the serial control port increments from the address just written toward 0x234 for multibyte I/O operations. Unused addresses are not skipped for these operations.

For multibyte accesses that cross Address 0x234 or Address 0x000 in MSB first mode, the SPI internally disables writes to subsequent registers and returns zeros for reads to subsequent registers.

Streaming mode always terminates when crossing address boundaries (as shown in Table 25).

Table 25. Streaming Mode (No Addresses Are Skipped)

Write Mode	Address Direction	Stop Sequence
MSB First	Decrement	..., 0x001, 0x000, stop

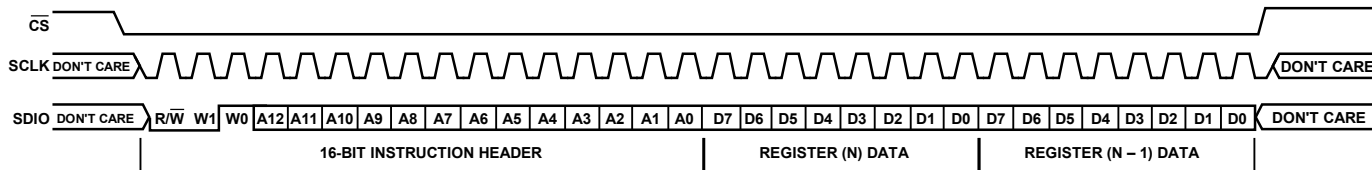

Figure 40. Serial Control Port Write—MSB First, 16-Bit Instruction, Two Bytes of Data

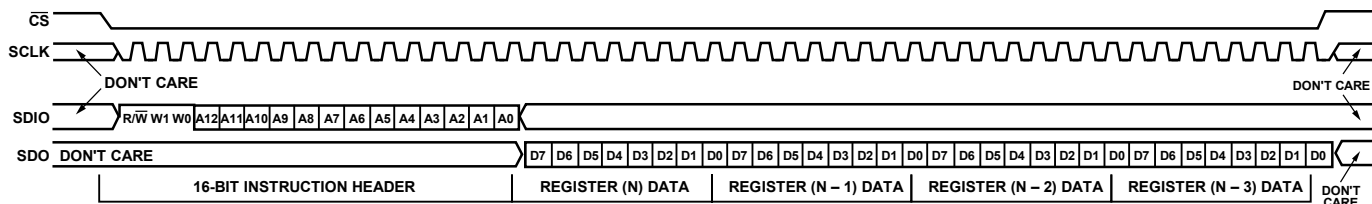

Figure 41. Serial Control Port Read—MSB First, 16-Bit Instruction, Four Bytes of Data

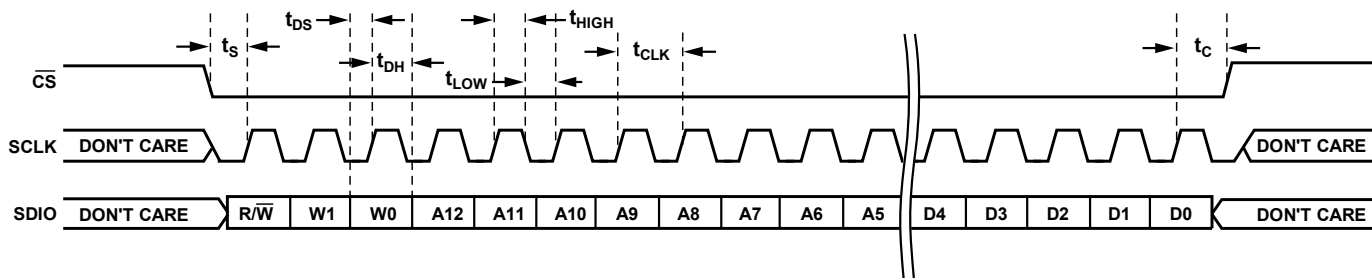

Figure 42. Serial Control Port Write—MSB First, 16-Bit Instruction, Timing Measurements

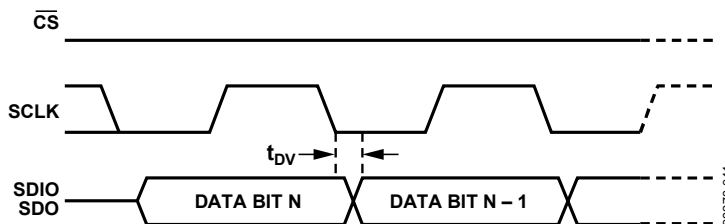

Figure 43. Timing Diagram for Serial Control Port Register Read

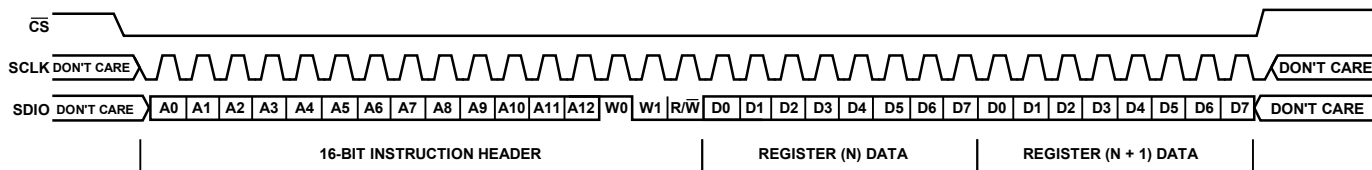

Figure 44. Serial Control Port Write—LSB First, 16-Bit Instruction, Two Bytes of Data

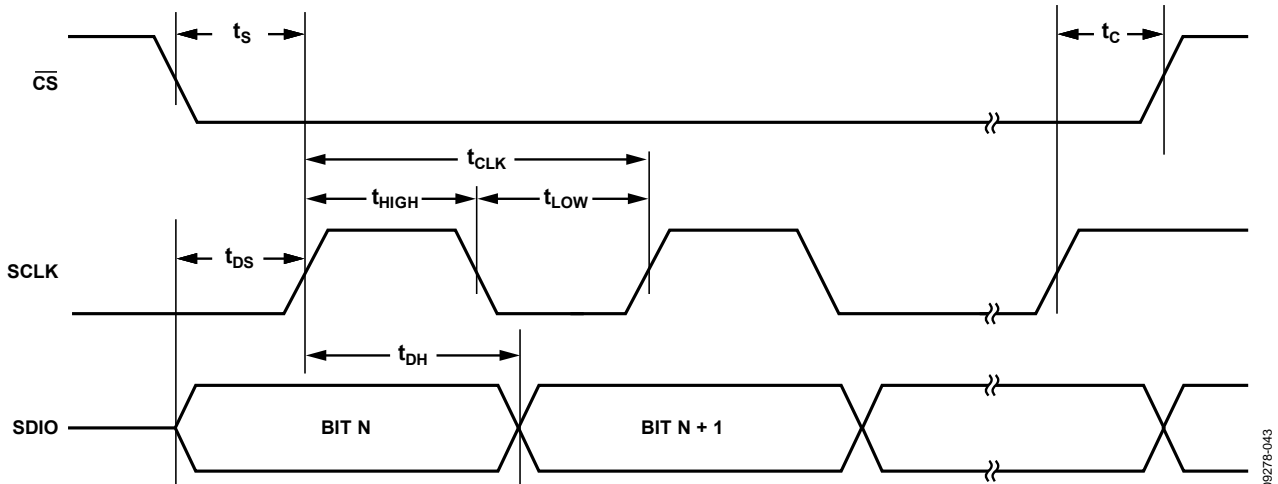

Figure 45. Serial Control Port Timing—Write

09278-043

Table 27. Serial Control Port Timing

Parameter	Description
t_{DS}	Setup time between data and rising edge of SCLK
t_{DH}	Hold time between data and rising edge of SCLK
t_{CLK}	Period of the clock
t_s	Setup time between the \overline{CS} falling edge and SCLK rising edge (start of communication cycle)
t_c	Setup time between the SCLK rising edge and \overline{CS} rising edge (end of communication cycle)
t_{HIGH}	Minimum period that SCLK should be in a logic high state
t_{LOW}	Minimum period that SCLK should be in a logic low state
t_{DV}	SCLK to valid SDIO and SDO (see Figure 43)

EEPROM OPERATIONS

The AD9523-1 contains an internal EEPROM (nonvolatile memory). The EEPROM can be programmed by the user to create and store a user-defined register setting file when the power is off. This setting file can be used for power-up and chip reset as a default setting. The EEPROM size is 512 bytes. See Table 58 and Table 59 for descriptions of the EEPROM registers that control EEPROM operation.

During the data transfer process, the write and read registers are generally not available via the serial port, except for one readback bit: Status_EEPROM (Register 0xB00, Bit 0).

To determine the data transfer state through the serial port in SPI mode, users can read the value of the Status_EEPROM bit (1 = data transfer in process and 0 = data transfer complete).

In I²C mode, the user can address the AD9523-1 slave port with the external I²C master (send an address byte to the AD9523-1). If the AD9523-1 responds with a no acknowledge bit, the data transfer was not received. If the AD9523-1 responds with an acknowledge bit, the data transfer process is complete. The user can monitor the Status_EEPROM bit or use Register 0x232, Bit 4, to program the STATUS0 pin to monitor the status of the data transfer (see Table 55).

To transfer all 512 bytes to the EEPROM, it takes approximately 46 ms. To transfer the contents of the EEPROM to the active register, it takes approximately 40 ms.

RESET, a hard reset (an asynchronous hard reset is executed by briefly pulling **RESET** low), restores the chip either to the setting stored in EEPROM (the EEPROM pin = 1) or to the on-chip setting (the EEPROM pin = 0). A hard reset also executes a SYNC operation that brings the outputs into phase alignment according to the default settings. When EEPROM is inactive (the EEPROM pin = 0), it takes ~2 μ s for the outputs to begin toggling after **RESET** is issued. When EEPROM is active (the EEPROM pin = 1), it takes ~40 ms for the outputs to toggle after **RESET** is brought high.

WRITING TO THE EEPROM

The EEPROM cannot be programmed directly through the serial port interface. To program the EEPROM and store a register setting file, follow these steps:

1. Program the AD9523-1 registers to the desired circuit state. If the user wants PLL2 to lock automatically after power-up, the calibrate VCO bit (Register 0x0F3, Bit 1) must be set to 1. This allows VCO calibration to start automatically after register loading. Note that a valid input reference signal must be present during VCO calibration.
2. Set the IO_Update bit (Bit 0, Register 0x234) to 1.
3. Program the EEPROM buffer registers, if necessary (see the Programming the EEPROM Buffer Segment section). This step is necessary only if users want to use the EEPROM to control the default settings of some (but not all) of the AD9523-1 registers, or if they want to control the register setting update sequence during power-up or chip reset.
4. Set the enable EEPROM write bit (Bit 0, Register 0xB02) to 1 to enable the EEPROM.
5. Set the REG2EEPROM bit (Bit 0, Register 0xB03) to 1. This starts the process of writing data into the EEPROM to create the EEPROM setting file. This enables the EEPROM controller to transfer the current register values, as well as the memory address and instruction bytes from the EEPROM buffer segment, into the EEPROM. After the write process is completed, the internal controller sets bit REG2EEPROM back to 0. Bit 0 of the Status_EEPROM register (Register 0xB00) is used to indicate the data transfer status between the EEPROM and the control registers (1 = data transfer in process, and 0 = data transfer complete). At the beginning of the data transfer, the Status_EEPROM bit is set to 1 by the EEPROM controller and cleared to 0 at the end of the data transfer. The user can access Status_EEPROM via the STATUS0 pin when the STATUS0 pin is programmed to monitor the Status_EEPROM bit. Alternatively, the user can monitor the Status_EEPROM bit directly.
6. When the data transfer is complete (Status_EEPROM = 0), set the enable EEPROM write bit (Register 0xB02, Bit 0) to 1. Clearing the enable EEPROM write bit to 0 disables writing to the EEPROM.

To ensure that the data transfer has completed correctly, verify that the EEPROM data error bit (Register 0xB01, Bit 0) = 0. A value of 1 in this bit indicates a data transfer error.

READING FROM THE EEPROM

The following reset-related events can start the process of restoring the settings stored in the EEPROM to the control registers. When the EEPROM_SEL pin is set high, do any of the following to initiate an EEPROM read:

- Power up the AD9523-1.
- Perform a hardware chip reset by pulling the **RESET** pin low and then releasing **RESET**.
- Set the self-clearing soft reset bit (Bit 5, Register 0x000) to 1.

When the EEPROM_SEL pin is set low, set the self-clearing Soft_EEPROM bit (Bit 1, Register 0xB02) to 1. The AD9523-1 then starts to read the EEPROM and loads the values into the AD9523-1 registers. If the EEPROM_SEL pin is low during reset or power-up, the EEPROM is not active, and the AD9523-1 default values are loaded instead.

When using the EEPROM to automatically load the AD9523-1 register values and lock the PLL, the calibrate VCO bit (Bit 1, Register 0x0F3) must be set to 1 when the register values are written to the EEPROM. This allows VCO calibration to start automatically after register loading. A valid input reference signal must be present during VCO calibration.

To ensure that the data transfer has completed correctly, verify that the EEPROM data error bit (Register 0xB01, Bit 0) is set to 0. A value of 1 in this bit indicates a data transfer error.

PROGRAMMING THE EEPROM BUFFER SEGMENT

The EEPROM buffer segment is a register space that allows the user to specify which groups of registers are stored to the EEPROM during EEPROM programming. Normally, this segment does not need to be programmed by the user. Instead, the default power-up values for the EEPROM buffer segment allow the user to store all of the register values from Register 0x000 to Register 0x234 to the EEPROM.

For example, if the user wants to load only the output driver settings from the EEPROM without disturbing the PLL register settings currently stored in the EEPROM, the EEPROM buffer segment can be modified to include only the registers that apply to the output drivers and exclude the registers that apply to the PLL configuration.

There are two parts to the EEPROM buffer segment: register section definition groups and operational codes. Each register section definition group contains the starting address and number of bytes to be written to the EEPROM.

If the AD9523-1 register map were continuous from Address 0x000 to Address 0x234, only one register section definition group would consist of a starting address of 0x000 and a length of 563 bytes. However, this is not the case. The AD9523-1 register map is noncontiguous, and the EEPROM is only 512 bytes long. Therefore, the register section definition group tells the EEPROM controller how the AD9523-1 register map is segmented.

There are three operational codes: IO_Update, end-of-data, and pseudo-end-of-data. It is important that the EEPROM buffer segment always have either an end-of-data or a pseudo-end-of-data operational code and that an IO_Update operation code appear at least once before the end-of-data operational code.

Register Section Definition Group

The register section definition group is used to define a continuous register section for the EEPROM profile. It consists of three bytes. The first byte defines how many continuous register bytes are in this group. If the user puts 0x000 in the first byte, it means there is only one byte in this group. If the user puts 0x001, it means there are two bytes in this group. The maximum number of registers in one group is 128.

The next two bytes are the low byte and high byte of the memory address (16 bits) of the first register in this group.

IO_Update (Operational Code 0x80)

The EEPROM controller uses this operational code to generate an IO_Update signal to update the active control register bank from the buffer register bank during the download process.

At a minimum, there should be at least one IO_Update operational code after the end of the final register section definition group. This is needed so that at least one IO_Update occurs after all of the AD9523-1 registers are loaded when the EEPROM is read. If this operational code is absent during a write to the EEPROM, the register values loaded from the EEPROM are not transferred to the active register space, and these values do not take effect after they are loaded from the EEPROM to the AD9523-1.

End-of-Data (Operational Code 0xFF)

The EEPROM controller uses this operational code to terminate the data transfer process between EEPROM and the control register during the upload and download processes. The last item appearing in the EEPROM buffer segment should be either this operational code or the pseudo-end-of-data operational code.

Pseudo-End-of-Data (Operational Code 0xFE)

The AD9523-1 EEPROM buffer segment has 23 bytes that can contain up to seven register section definition groups. If the user wants to define more than seven register section definition groups, the pseudo-end-of-data operational code can be used. During the upload process, when the EEPROM controller receives the pseudo-end-of-data operational code, it halts the data transfer process, clears the REG2EEPROM bit (Bit 0, Register 0xB03), and enables the AD9523-1 serial port. The user can then program the EEPROM buffer segment again and reinitiate the data transfer process by setting the REG2EEPROM bit to 1 and the IO_Update bit (Register 0x234, Bit 0) to 1. The internal I²C master then begins writing to the EEPROM, starting from the EEPROM address held from the last writing.

This sequence enables more discrete instructions to be written to the EEPROM than would otherwise be possible due to the limited size of the EEPROM buffer segment. It also permits the user to write to the same register multiple times with a different value each time.

Table 28. Example of an EEPROM Buffer Segment

Register Address (Hex)	Bit 7 (MSB)	Bit 6	Bit 5	Bit 4	Bit 3	Bit 2	Bit 1	Bit 0 (LSB)
Start EEPROM Buffer Segment								
0xA00	0	Number of bytes of the first group of registers (Bits[6:0])						
0xA01	Address of the first group of registers (Bits[15:8])							
0xA02	Address of the first group of registers (Bits[7:0])							
0xA03	0	Number of bytes of the second group of registers (Bits[6:0])						
0xA04	Address of the second group of registers (Bits[15:8])							
0xA05	Address of the second group of registers (Bits[7:0])							
0xA06	0	Number of bytes of the third group of registers (Bits[6:0])						
0xA07	Address of the third group of registers (Bits[15:8])							
0xA08	Address of the third group of registers (Bits[7:0])							
0xA09	IO_Update operational code (0x80)							
0xA0A	End-of-data operational code (0xFF)							

POWER DISSIPATION AND THERMAL CONSIDERATIONS

The AD9523-1 is a multifunctional, high speed device that targets a wide variety of clock applications. The numerous innovative features contained in the device each consume incremental power. If all outputs are enabled in the maximum frequency and mode that have the highest power, the safe thermal operating conditions of the device may be exceeded. Careful analysis and consideration of power dissipation and thermal management are critical elements in the successful application of the AD9523-1 device.

The AD9523-1 device is specified to operate within the industrial temperature range of -40°C to $+85^{\circ}\text{C}$. This specification is conditional, however, such that the absolute maximum junction temperature is not exceeded (as specified in Table 16). At high operating temperatures, extreme care must be taken when operating the device to avoid exceeding the junction temperature and potentially damaging the device.

Many variables contribute to the operating junction temperature within the device, including

- Selected driver mode of operation
- Output clock speed
- Supply voltage
- Ambient temperature

The combination of these variables determines the junction temperature within the AD9523-1 device for a given set of operating conditions.

The AD9523-1 is specified for an ambient temperature (T_A). To ensure that T_A is not exceeded, an airflow source can be used.

Use the following equation to determine the junction temperature on the application PCB:

$$T_j = T_{CASE} + (\Psi_{JT} \times PD)$$

where:

T_j is the junction temperature ($^{\circ}\text{C}$).

T_{CASE} is the case temperature ($^{\circ}\text{C}$) measured by the user at the top center of the package.

Ψ_{JT} is the value from Table 17.

PD is the power dissipation of the AD9523-1.

Values of θ_{JA} are provided for package comparison and PCB design considerations. θ_{JA} can be used for a first-order approximation of T_j by the equation

$$T_j = T_A + (\theta_{JA} \times PD)$$

where T_A is the ambient temperature ($^{\circ}\text{C}$).

Values of θ_{JC} are provided for package comparison and PCB design considerations when an external heat sink is required.

Values of Ψ_{JB} are provided for package comparison and PCB design considerations.

CLOCK SPEED AND DRIVER MODE

Clock speed directly and linearly influences the total power dissipation of the device and, therefore, the junction temperature. Two operating frequencies are listed under the incremental power dissipation parameter in Table 3. Using linear interpretation is a sufficient approximation for frequency not listed in the table. When calculating power dissipation for thermal consideration, the amount of power dissipated in the $100\ \Omega$ resistor should be removed. If using the data in Table 2, this power is already removed. If using the current vs. frequency graphs provided in the Typical Performance Characteristics section, the power into the load must be subtracted, using the following equation:

$$\frac{\text{Differential Output Voltage Swing}^2}{100\ \Omega}$$

EVALUATION OF OPERATING CONDITIONS

The first step in evaluating the operating conditions is to determine the maximum power consumption (PD) internal to the AD9523-1. The maximum PD excludes power dissipated in the load resistors of the drivers because such power is external to the device. Use the power dissipation specifications listed in Table 3 to calculate the total power dissipated for the desired configuration. The base typical configuration parameter in Table 3 lists a maximum power of 434.7 mW, which includes one LVPECL output at 122.88 MHz. For one LVDS output that is operating at 122.88 MHz, the power is 35 mW; for operation at 983.04 MHz, the power is 106 mW. Using linear interpolation, the power for operation at 245.76 MHz is 45 mW. Table 29 summarizes the incremental power dissipation from the base power configuration for two different examples.

Table 29. Temperature Gradient Examples

Description	Mode	Frequency (MHz)	Maximum Power (mW)
Example 1			
Base Typical Configuration			434.7
Output Driver	6 × LVPECL	122.88	306
Output Driver	3 × LVDS	61.44	89
Output Driver	3 × LVDS	245.76	135
Total Power			966
Example 2			
Base Typical Configuration			434.7
Output Driver	13 × LVPECL	983.04	2066
Total Power			2500

The second step is to multiply the power dissipated by the thermal impedance to determine the maximum power gradient. For this example, a thermal impedance of $\theta_{JA} = 20.1^{\circ}\text{C}/\text{W}$ was used.

Example 1

$$(966 \text{ mW} \times 20.1^{\circ}\text{C}/\text{W}) = 19.4^{\circ}\text{C}$$

With an ambient temperature of 85°C , the junction temperature is

$$T_j = 85^{\circ}\text{C} + 19.4^{\circ}\text{C} = 104^{\circ}\text{C}$$

This junction temperature is below the maximum allowable.

Example 2

$$(2500 \text{ mW} \times 20.1^{\circ}\text{C}/\text{W}) = 50.2^{\circ}\text{C}$$

With an ambient temperature of 85°C , the junction temperature is

$$T_j = 85^{\circ}\text{C} + 50^{\circ}\text{C} = 135^{\circ}\text{C}$$

This junction temperature is above the maximum allowable. The ambient temperature must be lowered by 20°C to operate in the condition of Example 2.

THERMALLY ENHANCED PACKAGE MOUNTING GUIDELINES

Refer to the [AN-772 Application Note](#), *A Design and Manufacturing Guide for the Lead Frame Chip Scale Package (LFCSP)*, for more information about mounting devices with an exposed paddle.

CONTROL REGISTERS

CONTROL REGISTER MAP

Register addresses that are not listed in Table 30 are not used, and writing to those registers has no effect. Registers that are marked as reserved should never have their values changed. When writing to registers with bits that are marked reserved, the user should take care to always write the default value for the reserved bits.

Table 30. Control Register Map

Addr (Hex)	Register Name	(MSB) Bit 7	Bit 6	Bit 5	Bit 4	Bit 3	Bit 2	Bit 1	(LSB) Bit 0	Default Value (Hex)	
Serial Port Configuration											
0x000	SPI mode serial port configuration	SDO active	LSB first/address increment	Soft reset	Reserved	Reserved	Soft reset	LSB first/address increment	SDO active	0x00	
	I ² C mode serial port configuration	Reserved	Reserved	Soft reset	Reserved	Reserved	Soft reset	Reserved	Reserved	0x00	
0x004	Readback control	Reserved	Reserved	Reserved	Reserved	Reserved	Reserved	Reserved	Read back active registers	0x00	
0x005	EEPROM customer version ID	EEPROM customer version ID[7:0] (LSB)								0x00	
0x006		EEPROM customer version ID[15:8] (MSB)								0x00	
Input PLL (PLL1)											
0x010	PLL1 REFA R divider control	10-bit REFA R divider[7:0] (LSB)								0x00	
0x011		Reserved						10-bit REFA R divider[9:8] (MSB)		0x00	
0x012	PLL1 REFB R divider control	10-bit REFB R divider[7:0] (LSB)								0x00	
0x013		Reserved						10-bit REFB R divider[9:8] (MSB)		0x00	
0x014	PLL1 reference test divider	Reserved	Reserved	REF_TEST divider						0x00	
0x015	PLL1 reserved	Reserved	Reserved	Reserved	Reserved	Reserved	Reserved	Reserved	Reserved	0x00	
0x016	PLL1 feedback N divider control	10-bit PLL1 feedback divider[7:0] (LSB)								0x00	
0x017		Reserved						10-bit PLL1 feedback divider[9:8] (MSB)		0x00	
0x018	PLL1 charge pump control	PLL1 charge pump tristate	PLL1 charge pump control								0x0C
0x019		Reserved	Reserved	Reserved	Enable SPI control of antibacklash pulse width	Antibacklash pulse width control		PLL1 charge pump mode		0x00	
0x01A	PLL1 input receiver control	REF_TEST input receiver enable	REFB differential receiver enable	REFA differential receiver enable	REFB receiver enable	REFA receiver enable	Input REFA, REFB receiver power-down control enable	OSC_IN single-ended receiver mode enable (CMOS mode)	OSC_IN differential receiver mode enable	0x00	
0x01B	REF_TEST, REFA, REFB, and ZD_IN control	Bypass REF_TEST divider	Bypass feedback divider	Zero delay mode	OSC_IN signal feedback for PLL1	ZD_IN single-ended receiver mode enable (CMOS mode)	ZD_IN differential receiver mode enable	REFB single-ended receiver mode enable (CMOS mode)	REFA single-ended receiver mode enable (CMOS mode)	0x00	
0x01C	PLL1 miscellaneous control	Enable REFB R divider independent division control	OSC_CTRL control voltage to VCC/2 when ref clock fails	Reserved	Reference selection mode			Bypass REFB R divider	Bypass REFA R divider	0x00	

Addr (Hex)	Register Name	(MSB) Bit 7	Bit 6	Bit 5	Bit 4	Bit 3	Bit 2	Bit 1	(LSB) Bit 0	Default Value (Hex)	
0x01D	PLL1 loop filter zero resistor control	Reserved	Reserved	Reserved	Reserved	PLL1 loop filter, R _{ZERO}				0x00	
Output PLL (PLL2)											
0x0F0	PLL2 charge pump control	PLL2 charge pump control								0x00	
0x0F1	PLL2 feedback N divider control	A counter			B counter						0x04
0x0F2	PLL2 control	PLL2 lock detector power-down	Reserved	Enable frequency doubler	Enable SPI control of antibacklash pulse width	Antibacklash pulse width control		PLL2 charge pump mode		0x03	
0x0F3	VCO control	Reserved	Reserved	Reserved	Force release of distribution sync when PLL2 is unlocked	Treat reference as valid	Force VCO to midpoint frequency	Calibrate VCO (not auto-clearing)	Reserved	0x00	
0x0F4	VCO dividers	Reserved	VCO Divider M2 power-down	VCO Divider M2		Reserved	VCO Divider M1 power-down	VCO Divider M1		0x00	
0x0F5	PLL2 loop filter control	Pole 2 resistor (R _{POLE2})		Zero resistor (R _{ZERO})			Pole 1 capacitor (C _{POLE1})			0x00	
0x0F6	(9 bits)	Reserved	Reserved	Reserved	Reserved	Reserved	Reserved	Reserved	Bypass internal R _{ZERO} resistor	0x00	
0x0F7	PLL2 R2 divider	Reserved	Reserved	Reserved	PLL R2 divider					0x00	
Clock Distribution											
0x190	Channel 0 control	Invert divider output	Ignore sync	Power down channel	Lower power mode	Driver mode				0x00	
0x191		10-bit channel divider[7:0] (LSB)								0x1F	
0x192		Divider phase[5:0]					10-bit channel divider[9:8] (MSB)			0x04	
0x193	Channel 1 control	Invert divider output	Ignore sync	Power down channel	Lower power mode	Driver mode				0x20	
0x194		10-bit channel divider[7:0] (LSB)								0x1F	
0x195		Divider phase[5:0]					10-bit channel divider[9:8] (MSB)			0x04	
0x196	Channel 2 control	Invert divider output	Ignore sync	Power down channel	Lower power mode	Driver mode				0x00	
0x197		10-bit channel divider[7:0] (LSB)								0x1F	
0x198		Divider phase[5:0]					10-bit channel divider[9:8] (MSB)			0x04	
0x199	Channel 3 control	Invert divider output	Ignore sync	Power down channel	Lower power mode	Driver mode				0x20	
0x19A		10-bit channel divider[7:0] (LSB)								0x1F	
0x19B		Divider phase[5:0]					10-bit channel divider[9:8] (MSB)			0x04	
0x19C	Channel 4 control	Invert divider output	Ignore sync	Power down channel	Lower power mode	Driver mode				0x00	
0x19D		10-bit channel divider[7:0] (LSB)								0x1F	
0x19E		Divider phase[5:0]					10-bit channel divider[9:8] (MSB)			0x04	
0x19F	Channel 5 control	Invert divider output	Ignore sync	Power down channel	Lower power mode	Driver mode				0x20	
0x1A0		10-bit channel divider[7:0] (LSB)								0x1F	
0x1A1		Divider phase[5:0]					10-bit channel divider[9:8] (MSB)			0x04	

AD9523-1

Addr (Hex)	Register Name	(MSB) Bit 7	Bit 6	Bit 5	Bit 4	Bit 3	Bit 2	Bit 1	(LSB) Bit 0	Default Value (Hex)	
0x1A2	Channel 6 control	Invert divider output	Ignore sync	Power down channel	Lower power mode	Driver mode				0x00	
0x1A3		10-bit channel divider[7:0] (LSB)									0x1F
0x1A4		Divider phase[5:0]							10-bit channel divider[9:8] (MSB)		
0x1A5	Channel 7 control	Invert divider output	Ignore sync	Power down channel	Lower power mode	Driver mode				0x20	
0x1A6		10-bit channel divider[7:0] (LSB)									0x1F
0x1A7		Divider phase[5:0]							10-bit channel divider[9:8] (MSB)		
0x1A8	Channel 8 control	Invert divider output	Ignore sync	Power down channel	Lower power mode	Driver mode				0x00	
0x1A9		10-bit channel divider[7:0] (LSB)									0x1F
0x1AA		Divider phase[5:0]							10-bit channel divider[9:8] (MSB)		
0x1AB	Channel 9 control	Invert divider output	Ignore sync	Power down channel	Lower power mode	Driver mode				0x20	
0x1AC		10-bit channel divider[7:0] (LSB)									0x1F
0x1AD		Divider phase[5:0]							10-bit channel divider[9:8] (MSB)		
0x1AE	Channel 10 control	Invert divider output	Ignore sync	Power down channel	Lower power mode	Driver mode				0x00	
0x1AF		10-bit channel divider[7:0] (LSB)									0x1F
0x1B0		Divider phase[5:0]							10-bit channel divider[9:8] (MSB)		
0x1B1	Channel 11 control	Invert divider output	Ignore sync	Power down channel	Lower power mode	Driver mode				0x20	
0x1B2		10-bit channel divider[7:0] (LSB)									0x1F
0x1B3		Divider phase[5:0]							10-bit channel divider[9:8] (MSB)		
0x1B4	Channel 12 control	Invert divider output	Ignore sync	Power down channel	Lower power mode	Driver mode				0x00	
0x1B5		10-bit channel divider[7:0] (LSB)									0x1F
0x1B6		Divider phase[5:0]							10-bit channel divider[9:8] (MSB)		
0x1B7	Channel 13 control	Invert divider output	Ignore sync	Power down channel	Lower power mode	Driver mode				0x20	
0x1B8		10-bit channel divider[7:0] (LSB)									0x1F
0x1B9		Divider phase[5:0]							10-bit channel divider[9:8] (MSB)		
0x1BA	PLL1 output control	CLK2 select[2:0]			PLL1 output CMOS driver strength	Out PLL1 output				0x00	
0x1BB	PLL1 output channel control	PLL1 output driver power-down	CLK2 select[5:3]		Reserved	Route VCXO clock to Ch 3 divider input	Route VCXO clock to Ch 2 divider input	Route VCXO clock to Ch 1 divider input	Route VCXO clock to Ch 0 divider input	0x80	
Readback											
0x22C	Readback 0	Status PLL2 reference clock	Status PLL2 feedback clock	Status VCXO	Status REF_TEST	Status REFB	Status REFA	Lock detect PLL2	Lock detect PLL1		
0x22D	Readback 1	Reserved	Reserved	Reserved	Reserved	Holdover active	Selected reference (in auto mode)	Reserved	VCO calibration in progress		
0x22E	Readback 2	Reserved	Reserved	Reserved	Reserved	Reserved	Reserved	Reserved	Reserved		
0x22F	Readback 3	Reserved	Reserved	Reserved	Reserved	Reserved	Reserved	Reserved	Reserved		

Addr (Hex)	Register Name	(MSB) Bit 7	Bit 6	Bit 5	Bit 4	Bit 3	Bit 2	Bit 1	(LSB) Bit 0	Default Value (Hex)
Other										
0x230	Status signals	Reserved	Reserved	Status Monitor 0 control						0x00
0x231		Reserved	Reserved	Status Monitor 1 control						0x00
0x232		Reserved	Reserved	Reserved	Enable Status_ EEPROM on STATUS0 pin	STATUS1 pin divider enable	STATUS0 pin divider enable	Reserved	Sync dividers (manual control) 0: sync signal inactive 1: dividers held in sync (same as SYNC pin low)	0x00
0x233	Power-down control	Reserved	Reserved	Reserved	Reserved	Reserved	PLL1 power-down	PLL2 power-down	Distribution power-down	0x07
0x234	Update all registers	Reserved							IO_Update	0x00
EEPROM Buffer										
0xA00	EEPROM Buffer Segment Register 1 to EEPROM Buffer Segment Register 3	Instruction (data)[7:0] (serial port configuration register)								0x00
0xA01		High byte of register address (serial port configuration register)								0x00
0xA02		Low byte of register address (serial port configuration register)								0x00
0xA03	EEPROM Buffer Segment Register 4 to EEPROM Buffer Segment Register 6	Instruction (data)[7:0] (reback control register)								0x02
0xA04		High byte of register address (reback control register)								0x00
0xA05		Low byte of register address (reback control register)								0x04
0xA06	EEPROM Buffer Segment Register 7 to EEPROM Buffer Segment Register 9	Instruction (data)[7:0] (PLL segment)								0x0E
0xA07		High byte of register address (PLL segment)								0x00
0xA08		Low byte of register address (PLL segment)								0x10
0xA09	EEPROM Buffer Segment Register 10 to EEPROM Buffer Segment Register 12	Instruction (data)[7:0] (PECL/CMOS output segment)								0x0E
0xA0A		High byte of register address (PECL/CMOS output segment)								0x00
0xA0B		Low byte of register address (PECL/CMOS output segment)								0xF0
0xA0C	EEPROM Buffer Segment Register 13 to EEPROM Buffer Segment Register 15	Instruction (data)[7:0] (divider segment)								0x2B
0xA0D		High byte of register address (divider segment)								0x01
0xA0E		Low byte of register address (divider segment)								0x90
0xA0F	EEPROM Buffer Segment Register 16 to EEPROM Buffer Segment Register 18	Instruction (data)[7:0] (clock input and REF segment)								0x01
0xA10		High byte of register address (clock input and REF segment)								0x01
0xA11		Low byte of register address (clock input and REF segment)								0xE0
0xA12	EEPROM Buffer Segment Register 19 to EEPROM Buffer Segment Register 21	Instruction (data)[7:0] (other segment)								0x03
0xA13		High byte of register address (other segment)								0x02
0xA14		Low byte of register address (other segment)								0x30
0xA15	EEPROM Buffer Segment Register 22	I/O update								0x80

AD9523-1

Addr (Hex)	Register Name	(MSB) Bit 7	Bit 6	Bit 5	Bit 4	Bit 3	Bit 2	Bit 1	(LSB) Bit 0	Default Value (Hex)
0xA16	EEPROM Buffer Segment Register 23	End of data								0xFF
EEPROM Control										
0xB00	Status_ EEPROM (read only)	Reserved	Reserved	Reserved	Reserved	Reserved	Reserved	Reserved	Status_ EEPROM (read only)	0x00
0xB01	EEPROM error checking readback (read only)	Reserved	Reserved	Reserved	Reserved	Reserved	Reserved	Reserved	EEPROM data error (read only)	0x00
0xB02	EEPROM Control 1	Reserved	Reserved	Reserved	Reserved	Reserved	Reserved	Soft_EEPROM	Enable EEPROM write	0x00
0xB03	EEPROM Control 2	Reserved	Reserved	Reserved	Reserved	Reserved	Reserved	Reserved	REG2EEPROM	0x00

CONTROL REGISTER MAP BIT DESCRIPTIONS**Serial Port Configuration (Address 0x000 to Address 0x006)****Table 31. SPI Mode Serial Port Configuration**

Address	Bits	Bit Name	Description
0x000	7	SDO active	Selects unidirectional or bidirectional data transfer mode. This bit is ignored in I ² C mode. 0: SDIO pin used for write and read; SDO is high impedance (default). 1: SDO used for read; SDIO used for write; unidirectional mode.
	6	LSB first/ address increment	SPI MSB or LSB data orientation. This bit is ignored in I ² C mode. 0: data-oriented MSB first; addressing decrements (default). 1: data-oriented LSB first; addressing increments.
	5	Soft reset	Soft reset. 1 (self-clearing): soft reset; restores default values to internal registers.
	4	Reserved	Reserved.
	[3:0]	Mirror[7:4]	Bits[3:0] should always mirror Bits[7:4] so that it does not matter whether the part is in MSB first or LSB first mode (see Register 0x000, Bit 6). Set bits as follows: Bit 0 = Bit 7. Bit 1 = Bit 6. Bit 2 = Bit 5. Bit 3 = Bit 4.
0x004	0	Read back active registers	For buffered registers, serial port readback reads from actual (active) registers instead of from the buffer. 0 (default): reads values currently applied to the internal logic of the device. 1: reads buffered values that take effect on the next assertion of the I/O update.

Table 32. I²C Mode Serial Port Configuration

Address	Bits	Bit Name	Description
0x000	[7:6]	Reserved	Reserved.
	5	Soft reset	Soft reset. 1 (self-clearing): soft reset; restores default values to internal registers.
	4	Reserved	Reserved.
	[3:0]	Mirror[7:4]	Bits[3:0] should always mirror Bits[7:4]. Set bits as follows: Bit 0 = Bit 7. Bit 1 = Bit 6. Bit 2 = Bit 5. Bit 3 = Bit 4.
0x004	0	Read back active registers	For buffered registers, serial port readback reads from actual (active) registers instead of from the buffer. 0 (default): reads values currently applied to the internal logic of the device. 1: reads buffered values that take effect on the next assertion of the I/O update.

Table 33. EEPROM Customer Version ID

Address	Bits	Bit Name	Description
0x005	[7:0]	EEPROM customer version ID (LSB)	16-bit EEPROM ID, Bits[7:0]. This register, along with Register 0x006, allows the user to store a unique ID to identify which version of the AD9523-1 register settings is stored in the EEPROM. It does not affect AD9523-1 operation in any way (default: 0x00).
0x006	[7:0]	EEPROM customer version ID (MSB)	16-bit EEPROM ID, Bits[15:8]. This register, along with Register 0x005, allows the user to store a unique ID to identify which version of the AD9523-1 register settings is stored in the EEPROM. It does not affect AD9523-1 operation in any way (default: 0x00).

AD9523-1

Input PLL (PLL1) (Address 0x010 to Address 0x01D)

Table 34. PLL1 REFA R Divider Control

Address	Bits	Bit Name	Description
0x010	[7:0]	REFA R divider	10-bit REFA R divider, Bits[7:0] (LSB). Divide-by-1 to divide-by-1023. 00000000, 00000001: divide-by-1.
0x011	[1:0]		10-bit REFA R divider, Bits[9:8] (MSB).

Table 35. PLL1 REFB R Divider Control¹

Address	Bits	Bit Name	Description
0x012	[7:0]	REFB R divider	10-bit REFB R divider, Bits[7:0] (LSB). Divide-by-1 to divide-by-1023. 00000000, 00000001: divide-by-1.
0x013	[1:0]		10-bit REFB R divider, Bits[9:8] (MSB).

¹ Requires Register 0x01C, Bit 7 = 1 for division that is independent of REFA division.

Table 36. PLL1 Reference Test Divider

Address	Bits	Bit Name	Description
0x014	[7:6]	Reserved	Reserved.
	[5:0]	REF_TEST divider	6-bit reference test divider. Divide-by-1 to divide-by-63. 000000, 000001: divide-by-1.

Table 37. PLL1 Reserved

Address	Bits	Bit Name	Description
0x015	[7:0]	Reserved	Reserved.

Table 38. PLL1 Feedback N Divider Control

Address	Bits	Bit Name	Description
0x016	[7:0]	PLL1 feedback N divider control (N_PLL1)	10-bit feedback divider, Bits[7:0] (LSB). Divide-by-1 to divide-by-1023. 00000000, 00000001: divide-by-1.
0x017	[1:0]		10-bit feedback divider, Bits[1:0] (MSB).

Table 39. PLL1 Charge Pump Control

Address	Bits	Bit Name	Description
0x018	7	PLL1 charge pump tristate	Tristates the PLL1 charge pump.
	[6:0]	PLL1 charge pump control	These bits set the magnitude of the PLL1 charge pump current. Granularity is ~0.5 μ A with a full-scale magnitude of ~63.5 μ A.
0x019	[7:5]	Reserved	Reserved.
	4	Enable SPI control of antibacklash pulse width	Controls the functionality of Register 0x019, Bits[3:2]. 0 (default): the device automatically controls the antibacklash period. 1: antibacklash period defined by Register 0x019, Bits[3:2].
	[3:2]	Antibacklash pulse width control	Controls the PFD antibacklash period. 00 (default): minimum. 01: low. 10: high. 11: maximum. These bits are ineffective unless Register 0x019, Bit 4 = 1.
	[1:0]	PLL1 charge pump mode	Controls the mode of the PLL1 charge pump. 00: tristate. 01: pump up. 10: pump down. 11 (default): normal.

Table 40. PLL1 Input Receiver Control

Address	Bits	Bit Name	Description
0x01A	7	REF_TEST input receiver enable	1: enabled. 0: disabled (default).
	6	REFB differential receiver enable	1: differential receiver mode. 0: single-ended receiver mode (also depends on Register 0x01B, Bit 1) (default).
	5	REFA differential receiver enable	1: differential receiver mode. 0: single-ended receiver mode (also depends on Register 0x01B, Bit 0) (default).
	4	REFB receiver enable	REFB receiver power-down control mode only when Bit 2 = 1. 1: enable REFB receiver. 0: power-down (default).
	3	REFA receiver enable	REFA receiver power-down control mode only when Bit 2 = 1. 1: enable REFA receiver. 0: power-down (default).
	2	Input REFA and REFB receiver power-down control enable	Enables control over power-down of the input receivers, REFA and REFB. 1: power-down control enabled. 0: both receivers enabled (default).
	1	OSC_IN single-ended receiver mode enable (CMOS mode)	Selects which single-ended input pin is enabled when in the single-ended receiver mode (Register 0x01A, Bit 0 = 0). 1: negative receiver from oscillator input ($\overline{\text{OSC_IN}}$ pin) selected. 0: positive receiver from oscillator input (OSC_IN pin) selected (default).
	0	OSC_IN differential receiver mode enable	1: differential receiver mode. 0: single-ended receiver mode (also depends on Bit 1) (default).

Table 41. REF_TEST, REFA, REFB, and ZD_IN Control

Address	Bits	Bit Name	Description
0x01B	7	Bypass REF_TEST divider	Puts the divider into bypass mode (same as programming the divider word to 0 or 1). 1: divider in bypass mode (divide = 1). 0: divider normal operation.
	6	Bypass feedback divider	Puts the divider into bypass mode (same as programming the divider word to 0 or 1). 1: divider in bypass mode (divide = 1). 0: divider normal operation.
	5	Zero delay mode	Selects the zero delay mode used (via the ZD_IN pin) when Register 0x01B, Bit 4 = 0. Otherwise, this bit is ignored. 1: internal zero delay mode. The zero delay receiver is powered down. The internal zero delay path from Distribution Divider Channel 0 is used. 0: external zero delay mode. The ZD_IN receiver is enabled.
	4	OSC_IN signal feedback for PLL1	Controls the input PLL feedback path, local feedback from the OSC_IN receiver or zero delay mode. 1: OSC_IN receiver input used for the input PLL feedback (non-zero delay mode). 0: zero delay mode enabled (also depends on Register 0x01B, Bit 4 to select the zero delay path).
	3	ZD_IN single-ended receiver mode enable (CMOS mode)	Selects which single-ended input pin is enabled when in the single-ended receiver mode (Register 0x01B, Bit 2 = 0). 1: ZD_IN pin enabled. 0: ZD_IN pin enabled.
	2	ZD_IN differential receiver mode enable	1: differential receiver mode. 0: single-ended receiver mode (also depends on Register 0x01B, Bit 3).
	1	REFB single-ended receiver mode enable (CMOS mode)	Selects which single-ended input pin is enabled when in single-ended receiver mode (Register 0x01A, Bit 6 = 0). 1: REFB pin enabled. 0: REFB pin enabled.
	0	REFA single-ended receiver mode enable (CMOS mode)	Selects which single-ended input pin is enabled when in single-ended receiver mode (Register 0x01A, Bit 5 = 0). 1: REFA pin enabled. 0: REFA pin enabled.

AD9523-1

Table 42. PLL1 Miscellaneous Control

Address	Bits	Bit Name	Description																																			
0x01C	7	Enable REFB R divider independent division control	1: REFB R divider is controlled by Register 0x012 and Register 0x013. 0: REFB R divider is set to the same setting as the REFA R divider (Register 0x010 and Register 0x011). This requires that, for the loop to stay locked, the REFA and REFB input frequencies must be the same.																																			
	6	OSC_CTRL control voltage to VCC/2 when reference clock fails	High permits the OSC_CTRL control voltage to be forced to midsupply when the feedback or input clocks fail. Low tristates the charge pump output. 1: OSC_CTRL control voltage goes to VCC/2. 0: OSC_CTRL control voltage tracks the tristated (high impedance) charge pump (through the buffer).																																			
	5	Reserved	Reserved.																																			
	[4:2]	Reference selection mode	Programs the REFA, REFB mode selection (default = 000).																																			
			<table border="1"> <thead> <tr> <th>REF_SEL Pin</th> <th>Bit 4</th> <th>Bit 3</th> <th>Bit 2</th> <th>Description</th> </tr> </thead> <tbody> <tr> <td>X¹</td> <td>0</td> <td>0</td> <td>0</td> <td>Nonrevertive: stay on REFB.</td> </tr> <tr> <td>X¹</td> <td>0</td> <td>0</td> <td>1</td> <td>Revert to REFA.</td> </tr> <tr> <td>X¹</td> <td>0</td> <td>1</td> <td>0</td> <td>Select REFA.</td> </tr> <tr> <td>X¹</td> <td>0</td> <td>1</td> <td>1</td> <td>Select REFB.</td> </tr> <tr> <td>0</td> <td>1</td> <td>X¹</td> <td>X¹</td> <td>REF_SEL pin = 0 (low): REFA.</td> </tr> <tr> <td>1</td> <td>1</td> <td>X¹</td> <td>X¹</td> <td>REF_SEL pin = 1 (high): REFB.</td> </tr> </tbody> </table>	REF_SEL Pin	Bit 4	Bit 3	Bit 2	Description	X ¹	0	0	0	Nonrevertive: stay on REFB.	X ¹	0	0	1	Revert to REFA.	X ¹	0	1	0	Select REFA.	X ¹	0	1	1	Select REFB.	0	1	X ¹	X ¹	REF_SEL pin = 0 (low): REFA.	1	1	X ¹	X ¹	REF_SEL pin = 1 (high): REFB.
REF_SEL Pin	Bit 4	Bit 3	Bit 2	Description																																		
X ¹	0	0	0	Nonrevertive: stay on REFB.																																		
X ¹	0	0	1	Revert to REFA.																																		
X ¹	0	1	0	Select REFA.																																		
X ¹	0	1	1	Select REFB.																																		
0	1	X ¹	X ¹	REF_SEL pin = 0 (low): REFA.																																		
1	1	X ¹	X ¹	REF_SEL pin = 1 (high): REFB.																																		
	1	Bypass REFB R divider	Puts the divider into bypass mode (same as programming divider word to 0 or 1). 1: divider in bypass mode (divide = 1). 0: divider normal operation.																																			
	0	Bypass REFA R divider	Puts the divider into bypass mode (same as programming divider word to 0 or 1). 1: divider in bypass mode (divide = 1). 0: divider normal operation.																																			

¹ X = don't care.

Table 43. PLL1 Loop Filter Zero Resistor Control

Address	Bits	Bit Name	Description																																																		
0x01D	[7:4]	Reserved	Reserved.																																																		
	[3:0]	PLL1 loop filter, R _{ZERO}	Programs the value of the zero resistor, R _{ZERO} .																																																		
			<table border="1"> <thead> <tr> <th>Bit 3</th> <th>Bit 2</th> <th>Bit 1</th> <th>Bit 0</th> <th>R_{ZERO} Value (kΩ)</th> </tr> </thead> <tbody> <tr> <td>0</td> <td>0</td> <td>0</td> <td>0</td> <td>883</td> </tr> <tr> <td>0</td> <td>0</td> <td>0</td> <td>1</td> <td>677</td> </tr> <tr> <td>0</td> <td>0</td> <td>1</td> <td>0</td> <td>341</td> </tr> <tr> <td>0</td> <td>0</td> <td>1</td> <td>1</td> <td>135</td> </tr> <tr> <td>0</td> <td>1</td> <td>0</td> <td>0</td> <td>10</td> </tr> <tr> <td>0</td> <td>1</td> <td>0</td> <td>1</td> <td>10</td> </tr> <tr> <td>0</td> <td>1</td> <td>1</td> <td>0</td> <td>10</td> </tr> <tr> <td>0</td> <td>1</td> <td>1</td> <td>1</td> <td>10</td> </tr> <tr> <td>1</td> <td>0</td> <td>0</td> <td>0</td> <td>Use external resistor</td> </tr> </tbody> </table>	Bit 3	Bit 2	Bit 1	Bit 0	R _{ZERO} Value (kΩ)	0	0	0	0	883	0	0	0	1	677	0	0	1	0	341	0	0	1	1	135	0	1	0	0	10	0	1	0	1	10	0	1	1	0	10	0	1	1	1	10	1	0	0	0	Use external resistor
Bit 3	Bit 2	Bit 1	Bit 0	R _{ZERO} Value (kΩ)																																																	
0	0	0	0	883																																																	
0	0	0	1	677																																																	
0	0	1	0	341																																																	
0	0	1	1	135																																																	
0	1	0	0	10																																																	
0	1	0	1	10																																																	
0	1	1	0	10																																																	
0	1	1	1	10																																																	
1	0	0	0	Use external resistor																																																	

Output PLL (PLL2) (Address 0x0F0 to Address 0x0F7)**Table 44. PLL2 Charge Pump Control**

Address	Bits	Bit Name	Description
0x0F0	[7:0]	PLL2 charge pump control	These bits set the magnitude of the PLL2 charge pump current. Granularity is ~3.5 μ A with a full-scale magnitude of ~900 μ A.

Table 45. PLL2 Feedback N Divider Control

Address	Bits	Bit Name	Description
0x0F1	[7:6]	A counter	A counter word.
	[5:0]	B counter	B counter word.
	Feedback Divider Constraints		
	A Counter (Bits[7:6])	B Counter (Bits[5:0])	Allowed N Division ($4 \times B + A$)
	A = 0	B = 3	12
	A = 0 or A = 1	B = 4	16, 17
	A = 0 to A = 2	B = 5	20, 21, 22
	A = 0 to A = 2	B = 6	24, 25, 26
	A = 0 to A = 3	B \geq 7	28, 29 ... continuous to 255

Table 46. PLL2 Control

Address	Bits	Bit Name	Description
0x0F2	7	PLL2 lock detector power-down	Controls power-down of the PLL2 lock detector. 1: lock detector powered down. 0: lock detector active.
	6	Reserved	Default = 0; value must remain 0.
	5	Enable frequency doubler	Enables doubling of the PLL2 reference input frequency. 1: enabled. 0: disabled.
	4	Enable SPI control of antibacklash pulse width	Controls the functionality of Register 0x0F2, Bits[2:1]. 0 (default): device automatically controls the antibacklash period. 1: antibacklash period defined by Register 0x0F2, Bits[2:1].
	[3:2]	Antibacklash pulse width control	Controls the PFD antibacklash period of PLL2. 00 (default): minimum. 01: low. 10: high. 11: maximum. These bits are ineffective unless Register 0x0F2, Bit 4 = 1.
	[1:0]	PLL2 charge pump mode	Controls the mode of the PLL2 charge pump. 00: tristate. 01: pump up. 10: pump down. 11 (default): normal.

Table 47. VCO Control

Address	Bits	Bit Name	Description
0x0F3	[7:5]	Reserved	Reserved.
	4	Force release of distribution sync when PLL2 is unlocked	0 (default): distribution is held in sync (static) until the output PLL locks. Then it is automatically released from sync with all dividers synchronized. 1: overrides the PLL2 lock detector state; forces release of the distribution from sync.
	3	Treat reference as valid	0 (default): uses the PLL1 VCXO indicator to determine when the reference clock to the PLL2 is valid. 1: treats the reference clock as valid even if PLL1 does not consider it to be valid.
	2	Force VCO to midpoint frequency	Selects VCO control voltage functionality. 0 (default): normal VCO operation. 1: forces VCO control voltage to midscale.
	1	Calibrate VCO (not autoclearing)	1: initiates VCO calibration (this is not an autoclearing bit). 0: resets the VCO calibration.
	0	Reserved	Reserved.

AD9523-1

Table 48. VCO Divider Control

Address	Bits	Bit Name	Description		
0x0F4	7	Reserved	Reserved.		
	6	VCO Divider M2 power-down	1: powers down the divider. 0: normal operation.		
	[5:4]	VCO Divider M2	Note that VCO Divider M2 connects to Output Channel 4 through Output Channel 9.		
			Bit 5	Bit 4	Divider Value
			0	0	Divide-by-3
			0	1	Divide-by-4
			1	0	Divide-by-5
	1	1	Divide-by-3		
	3	Reserved	Reserved.		
	2	VCO Divider M1 power-down	1: powers down the divider. 0: normal operation.		
[1:0]	VCO Divider M1	Note that VCO Divider M1 connects to all output channels.			
		Bit 1	Bit 0	Divider Value	
		0	0	Divide-by-3	
		0	1	Divide-by-4	
		1	0	Divide-by-5	
1	1	Divide-by-3			

Table 49. PLL2 Loop Filter Control

Address	Bits	Bit Name	Description			
0x0F5	[7:6]	Pole 2 resistor (R_{POLE2})	Bit 7	Bit 6	R_{POLE2} (Ω)	
			0	0	900	
			0	1	450	
			1	0	300	
			1	1	225	
	[5:3]	Zero resistor (R_{ZERO})	Bit 5	Bit 4	Bit 3	R_{ZERO} (Ω)
			0	0	0	3250
			0	0	1	2750
			0	1	0	2250
			0	1	1	2100
			1	0	0	3000
			1	0	1	2500
			1	1	0	2000
	1	1	1	1850		
	[2:0]	Pole 1 capacitor (C_{POLE1})	Bit 2	Bit 1	Bit 0	C_{POLE1} (pF)
			0	0	0	0
			0	0	1	8
			0	1	0	16
			0	1	1	24
			1	0	0	24
1			0	1	32	
1			1	0	40	
1			1	1	48	
0x0F6	[7:1]	Reserved	Reserved.			
	0	Bypass internal R_{ZERO} resistor	Bypasses the internal R_{ZERO} resistor ($R_{ZERO} = 0 \Omega$). Requires the use of a series external zero resistor. This bit is the MSB of the loop filter control register (Address 0x0F5 and Address 0x0F6).			

Table 50. PLL2 R2 Divider

Address	Bits	Bit Name	Description
0x0F7	[7:5]	Reserved	Reserved.
	[4:0]	PLL2 R2 divider	Divide-by-1 to divide-by-31. 00000, 00001: divide-by-1.

Clock Distribution (Register 0x190 to Register 0x1B9)

Table 51. Channel 0 to Channel 13 Control (This Same Map Applies to All 14 Channels)

Address	Bits	Bit Name	Description				
0x190	7	Invert divider output	Inverts the polarity of the divider's output clock.				
	6	Ignore sync	0: obeys chip-level SYNC signal (default). 1: ignores chip-level SYNC signal.				
	5	Power down channel	1: powers down the entire channel. 0: normal operation.				
	4	Lower power mode (differential modes only)	Reduces power used in the differential output modes (LVDS/LVPECL/HSTL). This reduction may result in power savings but at the expense of performance. Note that this bit does not affect output swing and current, just the internal driver power. 1: low strength/lower power. 0: normal operation.				
	[3:0]	Driver mode	Driver mode.				
			Bit 3	Bit 2	Bit 1	Bit 0	Driver Mode
			0	0	0	0	Tristate output
			0	0	0	1	LVPECL (8 mA)
			0	0	1	0	LVDS (3.5 mA)
			0	0	1	1	LVDS (7 mA)
			0	1	0	0	HSTL-0 (16 mA)
			0	1	0	1	HSTL-1 (8 mA)
			0	1	1	0	CMOS (both outputs in phase) + Pin: true phase relative to divider output – Pin: true phase relative to divider output
			0	1	1	1	CMOS (opposite phases on outputs) + Pin: true phase relative to divider output – Pin: complement phase relative to divider output
1			0	0	0	CMOS + Pin: true phase relative to divider output – Pin: high-Z	
1			0	0	1	CMOS + Pin: high-Z – Pin: true phase relative to divider output	
1			0	1	0	CMOS + Pin: high-Z – Pin: high-Z	
1	0	1	1	CMOS (both outputs in phase) + Pin: complement phase relative to divider output – Pin: complement phase relative to divider output			
1	1	0	0	CMOS (both outputs out of phase) + Pin: complement phase relative to divider output – Pin: true phase relative to divider output			
1	1	0	1	CMOS + Pin: complement phase relative to divider output – Pin: high-Z			
1	1	1	0	CMOS + Pin: high-Z – Pin: complement phase relative to divider output			
1	1	1	1	Tristate output			

AD9523-1

Address	Bits	Bit Name	Description
0x191	[7:0]	Channel divider, Bits[7:0] (LSB)	Division = Channel Divider Bits[9:0] + 1. For example, [9:0] = 0 is divided by 1, [9:0] = 1 is divided by 2 ... [9:0] = 1023 is divided by 1024. 10-bit channel divider, Bits[7:0] (LSB).
0x192	[7:2]	Divider phase	Divider initial phase after a sync is asserted relative to the divider input clock (from the VCO divider output). LSB = ½ of a period of the divider input clock. Phase = 0: no phase offset. Phase = 1: ½ period offset, ... Phase = 63: 31.5 period offset.
	[1:0]	Channel divider, Bits[9:8] (MSB)	10-bit channel divider, Bits[9:8] (MSB).

Table 52. PLL1 Output Control (PLL1_OUT, Pin 72)

Address	Bits	Bit Name	Description
0x1BA	[7:5]	CLK2 select[2:0]	Bits[2:0] of the VCO divider channel select. Bit 7 selects Channel Output 6. Bit 6 selects Channel Output 5. Bit 5 selects Channel Output 4. 0: VCO Divider M1. 1: VCO Divider M2.
	4	PLL1 output CMOS driver strength	CMOS driver strength. 1: weak. 0: strong.
	[3:0]	PLL1 output divider	0000: divide-by-1. 0001: divide-by-2 (default). 0010: divide-by-4. 0100: divide-by-8. 1000: divide-by-16. No other inputs permitted.

Table 53. PLL1 Output Channel Control

Address	Bits	Bit Name	Description
0x1BB	7	PLL1 output driver power-down	PLL1 output driver power-down.
	[6:4]	CLK2 select[5:3]	Bits[5:3] of the VCO divider channel select. Bit 6 selects Channel Output 9. Bit 5 selects Channel Output 8. Bit 4 selects Channel Output 7. 0: VCO Divider M1. 1: VCO Divider M2.
	3	Route VCXO clock to Channel 3 divider input	1: channel uses VCXO clock. Routes VCXO clock to divider input. 0: channel uses VCO divider output clock.
	2	Route VCXO clock to Channel 2 divider input	1: channel uses VCXO clock. Routes VCXO clock to divider input. 0: channel uses VCO divider output clock.
	1	Route VCXO clock to Channel 1 divider input	1: channel uses VCXO clock. Routes VCXO clock to divider input. 0: channel uses VCO divider output clock.
	0	Route VCXO clock to Channel 0 divider input	1: channel uses VCXO clock. Routes VCXO clock to divider input. 0: channel uses VCO divider output clock.

Readback (Address 0x22C to Address 0x22D)**Table 54. Readback Registers (Readback 0 and Readback 1)**

Address	Bits	Bit Name	Description
0x22C	7	Status PLL2 reference clock	1: OK. 0: off/clocks are missing.
	6	Status PLL2 feedback clock	1: OK. 0: off/clocks are missing.
	5	Status VCXO	1: OK. 0: off/clocks are missing.
	4	Status REF_TEST	1: OK. 0: off/clocks are missing.
	3	Status REFB	1: OK. 0: off/clocks are missing.
	2	Status REFA	1: OK. 0: off/clocks are missing.
	1	Lock detect PLL2	1: locked. 0: unlocked.
	0	Lock detect PLL1	1: locked. 0: unlocked.
0x22D	[7:4]	Reserved	Reserved.
	3	Holdover active	1: holdover is active (both references are missing). 0: normal operation.
	2	Selected reference (in auto mode)	Selected reference (applies only when the device automatically selects the reference; for example, not in manual control mode). 1: REFB. 0: REFA.
	1	Reserved	Reserved.
	0	VCO calibration in progress	1: VCO calibration in progress. 0: VCO calibration not in progress.

AD9523-1

Other (Address 0x230 to Address 0x234)

Table 55. Status Signals

Address	Bits	Bit Name	Description						
0x230	[7:6]	Reserved	Reserved.						
	[5:0]	Status Monitor 0 control	Bit 5	Bit 4	Bit 3	Bit 2	Bit 1	Bit 0	Muxout
			0	0	0	0	0	0	GND
			0	0	0	0	0	1	PLL1 and PLL2 locked
			0	0	0	0	1	0	PLL1 locked
			0	0	0	0	1	1	PLL2 locked
			0	0	0	1	0	0	Both references are missing (REFA and REFB)
			0	0	0	1	0	1	Both references are missing and PLL2 is locked
			0	0	0	1	1	0	REFB selected (applies only to auto select mode)
			0	0	0	1	1	1	REFA is OK
			0	0	1	0	0	0	REFB is OK
			0	0	1	0	0	1	REF_TEST is OK
			0	0	1	0	1	0	VCXO is OK
			0	0	1	0	1	1	PLL1 feedback is OK
			0	0	1	1	0	0	PLL2 reference clock is OK
			0	0	1	1	0	1	Reserved
			0	0	1	1	1	0	REFA and REFB are OK
			0	0	1	1	1	1	All clocks are OK (except REF_TEST)
			0	1	0	0	0	0	PLL1 feedback is divide-by-2
			0	1	0	0	0	1	PLL1 PFD down divide-by-2
			0	1	0	0	1	0	PLL1 REF divide-by-2
			0	1	0	0	1	1	PLL1 PFD up divide-by-2
			0	1	0	1	0	0	GND
			0	1	0	1	0	1	GND
			0	1	0	1	1	0	GND
			0	1	0	1	1	1	GND

Note that all bit combinations after 010111 are reserved.

Address	Bits	Bit Name	Description																																																																																																																																																																														
0x231	[7:6]	Reserved	Reserved.																																																																																																																																																																														
	[5:0]	Status Monitor 1 control	<table border="1"> <thead> <tr> <th>Bit 5</th> <th>Bit 4</th> <th>Bit 3</th> <th>Bit 2</th> <th>Bit 1</th> <th>Bit 0</th> <th>Muxout</th> </tr> </thead> <tbody> <tr><td>0</td><td>0</td><td>0</td><td>0</td><td>0</td><td>0</td><td>GND</td></tr> <tr><td>0</td><td>0</td><td>0</td><td>0</td><td>0</td><td>1</td><td>PLL1 and PLL2 locked</td></tr> <tr><td>0</td><td>0</td><td>0</td><td>0</td><td>1</td><td>0</td><td>PLL1 locked</td></tr> <tr><td>0</td><td>0</td><td>0</td><td>0</td><td>1</td><td>1</td><td>PLL2 locked</td></tr> <tr><td>0</td><td>0</td><td>0</td><td>1</td><td>0</td><td>0</td><td>Both references are missing (REFA and REFB)</td></tr> <tr><td>0</td><td>0</td><td>0</td><td>1</td><td>0</td><td>1</td><td>Both references are missing and PLL2 is locked</td></tr> <tr><td>0</td><td>0</td><td>0</td><td>1</td><td>1</td><td>0</td><td>REFB selected (applies only to auto select mode)</td></tr> <tr><td>0</td><td>0</td><td>0</td><td>1</td><td>1</td><td>1</td><td>REFA is OK</td></tr> <tr><td>0</td><td>0</td><td>1</td><td>0</td><td>0</td><td>0</td><td>REFB is OK</td></tr> <tr><td>0</td><td>0</td><td>1</td><td>0</td><td>0</td><td>1</td><td>REF_TEST is OK</td></tr> <tr><td>0</td><td>0</td><td>1</td><td>0</td><td>1</td><td>0</td><td>VCXO is OK</td></tr> <tr><td>0</td><td>0</td><td>1</td><td>0</td><td>1</td><td>1</td><td>PLL1 feedback is OK</td></tr> <tr><td>0</td><td>0</td><td>1</td><td>1</td><td>0</td><td>0</td><td>PLL2 reference clock is OK</td></tr> <tr><td>0</td><td>0</td><td>1</td><td>1</td><td>0</td><td>1</td><td>Reserved</td></tr> <tr><td>0</td><td>0</td><td>1</td><td>1</td><td>1</td><td>0</td><td>REFA and REFB are OK</td></tr> <tr><td>0</td><td>0</td><td>1</td><td>1</td><td>1</td><td>1</td><td>All clocks are OK (except REF_TEST)</td></tr> <tr><td>0</td><td>1</td><td>0</td><td>0</td><td>0</td><td>0</td><td>GND</td></tr> <tr><td>0</td><td>1</td><td>0</td><td>0</td><td>0</td><td>1</td><td>GND</td></tr> <tr><td>0</td><td>1</td><td>0</td><td>0</td><td>1</td><td>0</td><td>GND</td></tr> <tr><td>0</td><td>1</td><td>0</td><td>0</td><td>1</td><td>1</td><td>GND</td></tr> <tr><td>0</td><td>1</td><td>0</td><td>1</td><td>0</td><td>0</td><td>PLL2 feedback is divide-by-2</td></tr> <tr><td>0</td><td>1</td><td>0</td><td>1</td><td>0</td><td>1</td><td>PLL2 PFD down divide-by-2</td></tr> <tr><td>0</td><td>1</td><td>0</td><td>1</td><td>1</td><td>0</td><td>PLL2 REF divide-by-2</td></tr> <tr><td>0</td><td>1</td><td>0</td><td>1</td><td>1</td><td>1</td><td>PLL2 PFD up divide-by-2</td></tr> </tbody> </table> <p>Note that all bit combinations after 010111 are reserved.</p>	Bit 5	Bit 4	Bit 3	Bit 2	Bit 1	Bit 0	Muxout	0	0	0	0	0	0	GND	0	0	0	0	0	1	PLL1 and PLL2 locked	0	0	0	0	1	0	PLL1 locked	0	0	0	0	1	1	PLL2 locked	0	0	0	1	0	0	Both references are missing (REFA and REFB)	0	0	0	1	0	1	Both references are missing and PLL2 is locked	0	0	0	1	1	0	REFB selected (applies only to auto select mode)	0	0	0	1	1	1	REFA is OK	0	0	1	0	0	0	REFB is OK	0	0	1	0	0	1	REF_TEST is OK	0	0	1	0	1	0	VCXO is OK	0	0	1	0	1	1	PLL1 feedback is OK	0	0	1	1	0	0	PLL2 reference clock is OK	0	0	1	1	0	1	Reserved	0	0	1	1	1	0	REFA and REFB are OK	0	0	1	1	1	1	All clocks are OK (except REF_TEST)	0	1	0	0	0	0	GND	0	1	0	0	0	1	GND	0	1	0	0	1	0	GND	0	1	0	0	1	1	GND	0	1	0	1	0	0	PLL2 feedback is divide-by-2	0	1	0	1	0	1	PLL2 PFD down divide-by-2	0	1	0	1	1	0	PLL2 REF divide-by-2	0	1	0	1	1	1
Bit 5	Bit 4	Bit 3	Bit 2	Bit 1	Bit 0	Muxout																																																																																																																																																																											
0	0	0	0	0	0	GND																																																																																																																																																																											
0	0	0	0	0	1	PLL1 and PLL2 locked																																																																																																																																																																											
0	0	0	0	1	0	PLL1 locked																																																																																																																																																																											
0	0	0	0	1	1	PLL2 locked																																																																																																																																																																											
0	0	0	1	0	0	Both references are missing (REFA and REFB)																																																																																																																																																																											
0	0	0	1	0	1	Both references are missing and PLL2 is locked																																																																																																																																																																											
0	0	0	1	1	0	REFB selected (applies only to auto select mode)																																																																																																																																																																											
0	0	0	1	1	1	REFA is OK																																																																																																																																																																											
0	0	1	0	0	0	REFB is OK																																																																																																																																																																											
0	0	1	0	0	1	REF_TEST is OK																																																																																																																																																																											
0	0	1	0	1	0	VCXO is OK																																																																																																																																																																											
0	0	1	0	1	1	PLL1 feedback is OK																																																																																																																																																																											
0	0	1	1	0	0	PLL2 reference clock is OK																																																																																																																																																																											
0	0	1	1	0	1	Reserved																																																																																																																																																																											
0	0	1	1	1	0	REFA and REFB are OK																																																																																																																																																																											
0	0	1	1	1	1	All clocks are OK (except REF_TEST)																																																																																																																																																																											
0	1	0	0	0	0	GND																																																																																																																																																																											
0	1	0	0	0	1	GND																																																																																																																																																																											
0	1	0	0	1	0	GND																																																																																																																																																																											
0	1	0	0	1	1	GND																																																																																																																																																																											
0	1	0	1	0	0	PLL2 feedback is divide-by-2																																																																																																																																																																											
0	1	0	1	0	1	PLL2 PFD down divide-by-2																																																																																																																																																																											
0	1	0	1	1	0	PLL2 REF divide-by-2																																																																																																																																																																											
0	1	0	1	1	1	PLL2 PFD up divide-by-2																																																																																																																																																																											
0x232	[7:5]	Reserved	Reserved.																																																																																																																																																																														
	4	Enable Status_EEPROM on STATUS0 pin	Enables the EEPROM status on the STATUS0 pin. 1: enable status.																																																																																																																																																																														
	3	STATUS1 pin divider enable	Enables a divide-by-4 on the STATUS1 pin, allowing dynamic signals to be viewed at a lower frequency (such as the PFD input clocks). Not to be used with dc states on the status pins, which occur when the settings of Register 0x231, Bits[5:0] are in the range of 000000 to 001111. 1: enabled. 0: disabled.																																																																																																																																																																														
	2	STATUS0 pin divider enable	Enables a divide-by-4 on the STATUS0 pin, allowing dynamic signals to be viewed at a lower frequency (such as the PFD input clocks). Not to be used with dc states on the status pins, which occur when the settings of Register 0x230, Bits[5:0] are in the range of 000000 to 001111. 1: enable. 0: disable.																																																																																																																																																																														
	1	Reserved	Reserved.																																																																																																																																																																														
0	Sync dividers (manual control)	Set bit to put dividers in sync; clear bit to release. Functions like SYNC pin low. 1: sync. 0: normal.																																																																																																																																																																															

AD9523-1

Table 56. Power-Down Control

Address	Bits	Bit Name	Description
0x233	[7:3]	Reserved	Reserved.
	2	PLL1 power-down	1: power-down (default). 0: normal operation.
	1	PLL2 power-down	1: power-down (default). 0: normal operation.
	0	Distribution power-down	Powers down the distribution. 1: power-down (default). 0: normal operation.

Table 57. Update All Registers

Address	Bits	Bit Name	Description
0x234	[7:1]	Reserved	Reserved.
	0	IO_Update	This bit must be set to 1 to transfer the contents of the buffer registers into the active registers, which happens on the next SCLK rising edge. This bit is self-clearing; that is, it does not have to be set back to 0. 1 (self-clearing): update all active registers to the contents of the buffer registers.

EEPROM Buffer (Address 0xA00 to Address 0xA16)

Table 58. EEPROM Buffer Segment

Address	Bits	Bit Name	Description
0xA00 to 0xA16	[7:0]	EEPROM Buffer Segment Register 1 to EEPROM Buffer Segment Register 23	The EEPROM buffer segment section stores the starting address and number of bytes that are to be stored and read back to and from the EEPROM. Because the register space is noncontiguous, the EEPROM controller needs to know the starting address and number of bytes in the register space to store and retrieve from the EEPROM. In addition, there are special instructions for the EEPROM controller: operational codes (that is, IO_Update and end-of-data) that are also stored in the EEPROM buffer segment. The on-chip default setting of the EEPROM buffer segment registers is designed such that all registers are transferred to/from the EEPROM, and an IO_Update is issued after the transfer (see the Programming the EEPROM Buffer Segment section).

EEPROM Control (Address 0xB00 to Address 0xB03)

Table 59. Status_EEPROM

Address	Bits	Bit Name	Description
0xB00	[7:1]	Reserved	Reserved.
	0	Status_EEPROM (read only)	This read-only bit indicates the status of the data transferred between the EEPROM and the buffer register bank during the writing and reading of the EEPROM. This signal is also available at the STATUS0 pin when Register 0x232, Bit 4, is set. 0: data transfer is complete. 1: data transfer is not complete.

Table 60. EEPROM Error Checking Readback

Address	Bits	Bit Name	Description
0xB01	[7:1]	Reserved	Reserved.
	0	EEPROM data error (read only)	This read-only bit indicates an error during the data transfer between the EEPROM and the buffer. 0: no error; data is correct. 1: incorrect data detected.

Table 61. EEPROM Control 1

Address	Bits	Bit Name	Description
0xB02	[7:2]	Reserved	Reserved.
	1	Soft_EEPROM	When the EEPROM_SEL pin is tied low, setting the Soft_EEPROM bit resets the AD9523-1 using the settings saved in EEPROM. 1: soft reset with EEPROM settings (self-clearing).
	0	Enable EEPROM write	Enables the user to write to the EEPROM. 0: EEPROM write protection is enabled. User cannot write to EEPROM (default). 1: EEPROM write protection is disabled. User can write to EEPROM.

Table 62. EEPROM Control 2

Address	Bits	Bit Name	Description
0xB03	[7:1]	Reserved	Reserved.
	0	REG2EEPROM	Transfers data from the buffer register to the EEPROM (self-clearing). 1: setting this bit initiates the data transfer from the buffer register to the EEPROM (writing process); it is reset by the I ² C master after the data transfer is done.

OUTLINE DIMENSIONS

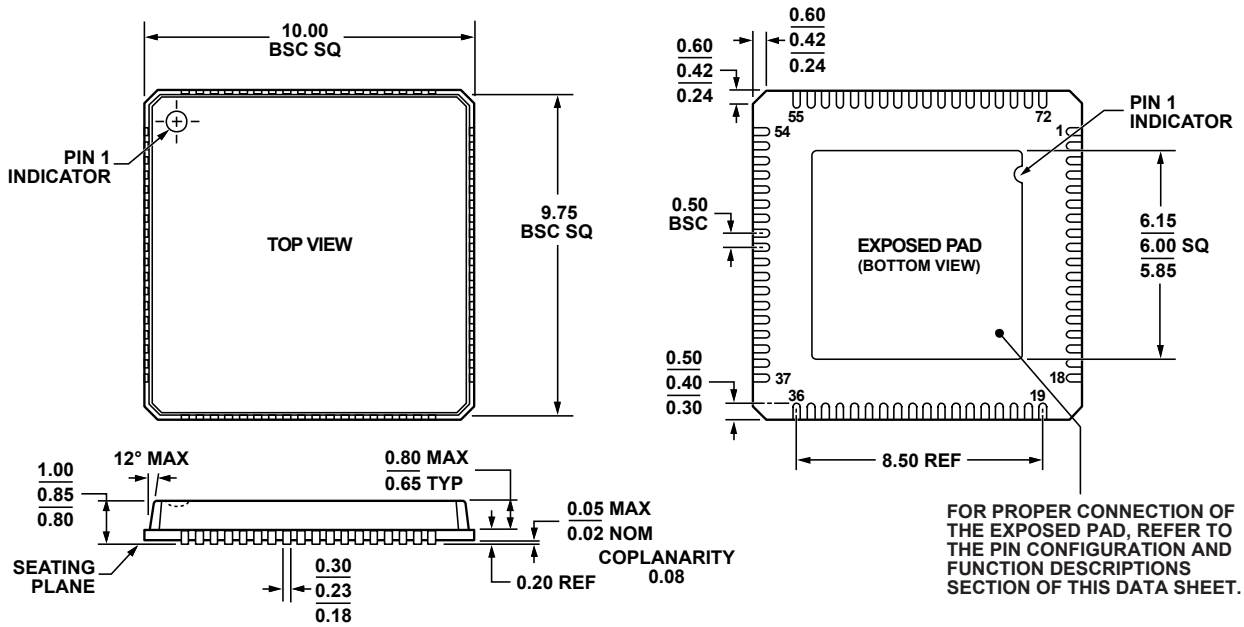

COMPLIANT TO JEDEC STANDARDS MO-220-VNND-4

Figure 46. 72-Lead Lead Frame Chip Scale Package [LFCSP_VQ]
 10 mm × 10 mm Body, Very Thin Quad
 (CP-72-7)
 Dimensions shown in millimeters

052809-A

ORDERING GUIDE

Model ¹	Temperature Range	Package Description	Package Option
AD9523-1BCPZ	-40°C to +85°C	72-Lead Lead Frame Chip Scale Package [LFCSP_VQ]	CP-72-7
AD9523-1BCPZ-REEL7	-40°C to +85°C	72-Lead Lead Frame Chip Scale Package [LFCSP_VQ]	CP-72-7
AD9523-1/PCBZ		Evaluation Board	

¹ Z = RoHS Compliant Part.

NOTES

NOTES

I²C refers to a communications protocol originally developed by Philips Semiconductors (now NXP Semiconductors).



Компания «ЭлектроПласт» предлагает заключение долгосрочных отношений при поставках импортных электронных компонентов на взаимовыгодных условиях!

Наши преимущества:

- Оперативные поставки широкого спектра электронных компонентов отечественного и импортного производства напрямую от производителей и с крупнейших мировых складов;
- Поставка более 17-ти миллионов наименований электронных компонентов;
- Поставка сложных, дефицитных, либо снятых с производства позиций;
- Оперативные сроки поставки под заказ (от 5 рабочих дней);
- Экспресс доставка в любую точку России;
- Техническая поддержка проекта, помощь в подборе аналогов, поставка прототипов;
- Система менеджмента качества сертифицирована по Международному стандарту ISO 9001;
- Лицензия ФСБ на осуществление работ с использованием сведений, составляющих государственную тайну;
- Поставка специализированных компонентов (Xilinx, Altera, Analog Devices, Intersil, Interpoint, Microsemi, Aeroflex, Peregrine, Syfer, Eurofarad, Texas Instrument, Miteq, Cobham, E2V, MA-COM, Hittite, Mini-Circuits, General Dynamics и др.);

Помимо этого, одним из направлений компании «ЭлектроПласт» является направление «Источники питания». Мы предлагаем Вам помощь Конструкторского отдела:

- Подбор оптимального решения, техническое обоснование при выборе компонента;
- Подбор аналогов;
- Консультации по применению компонента;
- Поставка образцов и прототипов;
- Техническая поддержка проекта;
- Защита от снятия компонента с производства.



Как с нами связаться

Телефон: 8 (812) 309 58 32 (многоканальный)

Факс: 8 (812) 320-02-42

Электронная почта: org@eplast1.ru

Адрес: 198099, г. Санкт-Петербург, ул. Калинина, дом 2, корпус 4, литера А.