

## NPN-SWITCHING SILICON TRANSISTOR

Qualified per MIL-PRF-19500/251

### DEVICES

<b>2N2218</b>	<b>2N2219</b>
<b>2N2218A</b>	<b>2N2219A</b>
<b>2N2218AL</b>	<b>2N2219AL</b>

### LEVELS

**JAN**  
**JANTX**  
**JANTXV**  
**JANS \***

\* Also available in Radiation Hardened versions. See datasheet for JANSR2N2218 & JANSR2N2219

### ABSOLUTE MAXIMUM RATINGS ( $T_C = +25^\circ\text{C}$ unless otherwise noted)

Parameters / Test Conditions	Symbol	2N2218 2N2219	2N221A; L 2N2219A; L	Unit
Collector-Emitter Voltage	$V_{CEO}$	30	50	Vdc
Collector-Base Voltage	$V_{CBO}$	60	75	Vdc
Emitter-Base Voltage	$V_{EBO}$	5.0	6.0	Vdc
Collector Current	$I_C$	800		mA
Total Power Dissipation	$P_T$	@ $T_A = +25^\circ\text{C}$	0.8	W
		@ $T_C = +25^\circ\text{C}$	3.0	W
Operating & Storage Junction Temp. Range	$T_{op}, T_{stg}$	-55 to +200		$^\circ\text{C}$

### THERMAL CHARACTERISTICS

Parameters / Test Conditions	Symbol	Value	Unit
Thermal Resistance, Junction-to-Case	$R_{\theta JC}$	59	$^\circ\text{C}/\text{W}$

**Note:** (1) Derate linearly 4.6mW/ $^\circ\text{C}$  above  $T_A > +25^\circ\text{C}$   
 (2) Derate linearly 17.0mW/ $^\circ\text{C}$  above  $T_C > +25^\circ\text{C}$

### ELECTRICAL CHARACTERISTICS ( $T_A = +25^\circ\text{C}$ , unless otherwise noted)

Parameters / Test Conditions	Symbol	Min.	Max.	Unit
<b>OFF CHARACTERISTICS</b>				
Collector-Emitter Breakdown Voltage $I_E = 10\text{mA}$	$V_{(BR)CEO}$	30	50	Vdc
2N2218; 2N2219 2N2218A; 2N2219A / AL				
Emitter-Base Cutoff Current $V_{EB} = 5.0\text{Vdc}$	$I_{EBO}$		10	$\mu\text{A}$
$V_{EB} = 6.0\text{Vdc}$			10	$\eta\text{A}$
$V_{EB} = 4.0\text{Vdc}$			10	
Collector-Base Cutoff Current $V_{CE} = 30\text{Vdc}$	$I_{CES}$		10	$\eta\text{A}$
$V_{CE} = 50\text{Vdc}$			10	

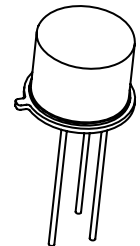

**TO-39 (TO-205AD)**  
 2N2218, 2N2218A  
 2N2219, 2N2219A

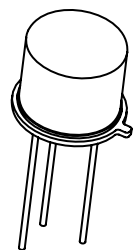

**TO-5**  
 2N2218AL  
 2N2219AL

**ELECTRICAL CHARACTERISTICS ( $T_A = +25^\circ\text{C}$ , unless otherwise noted) (Con't)**

Parameters / Test Conditions	Symbol	Min.	Max.	Unit	
Collector-Base Cutoff Current					
$V_{CB} = 50\text{Vdc}$ 2N2218; 2N2219	$I_{CBO}$		10	$\eta\text{Adc}$	
$V_{CB} = 60\text{Vdc}$ 2N2218; 2N2219			10	$\mu\text{Adc}$	
$V_{CB} = 60\text{Vdc}$ 2N2218A; 2N2219A / AL			10	$\eta\text{Adc}$	
$V_{CB} = 75\text{Vdc}$ 2N2218A; 2N2219A / AL			10	$\mu\text{Adc}$	
<b>ON CHARACTERISTICS (3)</b>					
Forward-Current Transfer Ratio					
$I_C = 0.1\text{mA}$ , $V_{CE} = 10\text{Vdc}$ 2N2218 2N2219 2N2218A; 2N2218AL 2N2219A; 2N2219AL	$h_{FE}$	20 35 30 50			
$I_C = 1.0\text{mA}$ , $V_{CE} = 10\text{Vdc}$ 2N2218 2N2219 2N2218A; 2N2218AL 2N2219A; 2N2219AL		25 50 35 75	150 325 150 325		
$I_C = 10\text{mA}$ , $V_{CE} = 10\text{Vdc}$ 2N2218 2N2219 2N2218A; 2N2218AL 2N2219A; 2N2219AL		35 75 40 100			
$I_C = 150\text{mA}$ , $V_{CE} = 10\text{Vdc}$ 2N2218; A; AL 2N2219; A; AL		40 100	120 300		
$I_C = 500\text{mA}$ , $V_{CE} = 10\text{Vdc}$ 2N2218; A; AL 2N2219; A; AL		20 30			
Collector-Emitter Saturation Voltage					
$I_C = 150\text{mA}$ , $I_B = 15\text{mA}$ 2N2218; 2N2219 2N2218A; 2N2219A / AL		$V_{CE(sat)}$		0.4 0.3	Vdc
$I_C = 500\text{mA}$ , $I_B = 50\text{mA}$ 2N2218; 2N2219 2N2218A; 2N2219A / AL				1.6 1.0	
Base-Emitter Saturation Voltage					
$I_C = 150\text{mA}$ , $I_B = 15\text{mA}$ 2N2218; 2N2219 2N2218A; 2N2219A / AL		$V_{BE(sat)}$	0.6 0.6	1.3 1.2	Vdc
$I_C = 500\text{mA}$ , $I_B = 50\text{mA}$ 2N2218; 2N2219 2N2218A; 2N2219A / AL				2.6 2.0	

## DYNAMIC CHARACTERISTICS

Parameters / Test Conditions	Symbol	Min.	Max.	Unit
Magnitude of Small-Signal Forward Current Transfer Ratio $I_C = 20\text{mA}$ , $V_{CE} = 20\text{V}$ , $f = 100\text{MHz}$	$ h_{fe} $	2.5	12	
Small-Signal Forward Current Transfer Ratio $I_C = 1.0\text{mA}$ , $V_{CE} = 10\text{V}$ , $f = 1.0\text{kHz}$	$h_{fe}$	2N2218	25	
		2N2219	50	
		2N2218A, AL	35	
		2N2219A, AL	75	
Output Capacitance $V_{CB} = 10\text{V}$ , $I_E = 0$ , $100\text{kHz} \leq f \leq 1.0\text{MHz}$	$C_{obo}$		8.0	pF
Input Capacitance $V_{EB} = 0.5\text{V}$ , $I_C = 0$ , $100\text{kHz} \leq f \leq 1.0\text{MHz}$	$C_{ibo}$		25	pF

## SWITCHING CHARACTERISTICS

Parameters / Test Conditions	Symbol	Min.	Max.	Unit
$V_{CC} = 30\text{V}$ ; $I_C = 150\text{mA}$ ; $I_{B1} = 15\text{mA}$				
Turn-On Time (See Figure 3 of MIL-PRF-19500/251)	$t_{on}$	2N2218, 2N2219	40	$\eta\text{s}$
		2N2218A, 2N2219A / AL	35	
Turn-Off Time (See Figure 4 of MIL-PRF-19500/251)	$t_{off}$	2N2218, 2N2219	250	$\eta\text{s}$
		2N2218A, 2N2219A / AL	300	

(3) Pulse Test: Pulse Width = 300 $\mu\text{s}$ , Duty Cycle  $\leq 2.0\%$ .

## PACKAGE DIMENSIONS

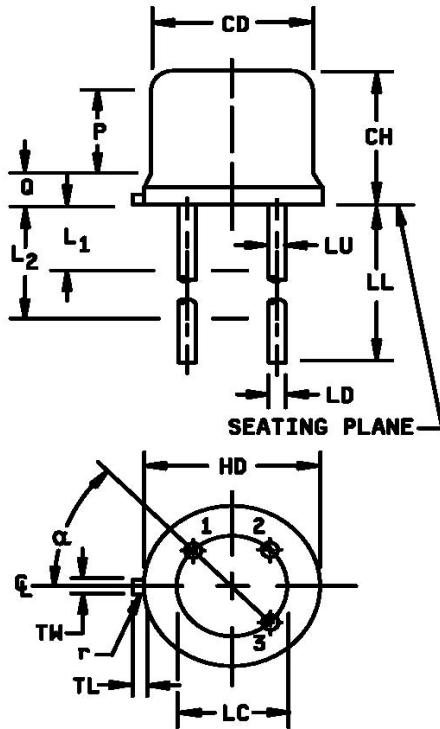

Symbol	Dimensions				Notes
	Inches		Millimeters		
	Min	Max	Min	Max	
CD	.305	.335	7.75	8.51	
CH	.240	.260	6.10	6.60	
HD	.335	.370	8.51	9.40	
LC	.200 TP		5.08 TP		7
LD	.016	.019	0.41	0.48	8, 9
LL	See note 14				
LU	.016	.019	0.41	0.48	8, 9
L <sub>1</sub>		.050		1.27	8, 9
L <sub>2</sub>	.250		6.35		8, 9
P	.100		2.54		7
Q		.030		0.76	5
TL	.029	.045	0.74	1.14	3, 4
TW	.028	.034	0.71	0.86	3
r		.010		0.25	10
α	45° TP		45° TP		7

### NOTES:

- Dimensions are in inches.
- Millimeters are given for general information only.
- Beyond r (radius) maximum, TW shall be held for a minimum length of .011 (0.28 mm).
- Dimension TL measured from maximum HD.
- Body contour optional within zone defined by HD, CD, and Q.
- CD shall not vary more than .010 inch (0.25 mm) in zone P. This zone is controlled for automatic handling.
- Leads at gauge plane .054 +.001 -.000 inch (1.37 +0.03 -0.00 mm) below seating plane shall be within .007 inch (0.18 mm) radius of true position (TP) at maximum material condition (MMC) relative to tab at MMC.
- Dimension LU applies between L1 and L2. Dimension LD applies between L2 and LL minimum. Diameter is uncontrolled in L1 and beyond LL minimum.
- All three leads.
- The collector shall be internally connected to the case.
- Dimension r (radius) applies to both inside corners of tab.
- In accordance with ASME Y14.5M, diameters are equivalent to  $\phi x$  symbology.
- Lead 1 = emitter, lead 2 = base, lead 3 = collector.
- For L suffix devices (TO-5), dimension LL = 1.5 inches (38.10 mm) min. and 1.75 inches (44.45 mm) max. For non-L suffix types (TO-39), dimension LL = .5 inch (12.70 mm) min. and .750 inch (19.05 mm) max.

**FIGURE 1.** Physical dimensions (similar to TO-39, TO-5).



Компания «ЭлектроПласт» предлагает заключение долгосрочных отношений при поставках импортных электронных компонентов на взаимовыгодных условиях!

Наши преимущества:

- Оперативные поставки широкого спектра электронных компонентов отечественного и импортного производства напрямую от производителей и с крупнейших мировых складов;
- Поставка более 17-ти миллионов наименований электронных компонентов;
- Поставка сложных, дефицитных, либо снятых с производства позиций;
- Оперативные сроки поставки под заказ (от 5 рабочих дней);
- Экспресс доставка в любую точку России;
- Техническая поддержка проекта, помощь в подборе аналогов, поставка прототипов;
- Система менеджмента качества сертифицирована по Международному стандарту ISO 9001;
- Лицензия ФСБ на осуществление работ с использованием сведений, составляющих государственную тайну;
- Поставка специализированных компонентов (Xilinx, Altera, Analog Devices, Intersil, Interpoint, Microsemi, Aeroflex, Peregrine, Syfer, Eurofarad, Texas Instrument, Miteq, Cobham, E2V, MA-COM, Hittite, Mini-Circuits, General Dynamics и др.);

Помимо этого, одним из направлений компании «ЭлектроПласт» является направление «Источники питания». Мы предлагаем Вам помощь Конструкторского отдела:

- Подбор оптимального решения, техническое обоснование при выборе компонента;
- Подбор аналогов;
- Консультации по применению компонента;
- Поставка образцов и прототипов;
- Техническая поддержка проекта;
- Защита от снятия компонента с производства.



#### Как с нами связаться

**Телефон:** 8 (812) 309 58 32 (многоканальный)

**Факс:** 8 (812) 320-02-42

**Электронная почта:** [org@eplast1.ru](mailto:org@eplast1.ru)

**Адрес:** 198099, г. Санкт-Петербург, ул. Калинина, дом 2, корпус 4, литера А.