

# Certified low-power, low-voltage accelerometer

## LPA100T-D2

### SPECIFICATIONS

<b>Sensitivity, ±5%, 25°C</b>	50 mV/g
<b>Acceleration range</b>	25 g peak
<b>Amplitude nonlinearity</b>	1%
<b>Frequency response:</b>	
±5%	3 - 5,000 Hz
±10%	1 - 9,000 Hz
±3 dB	0.3 - 15,000 Hz
<b>Resonance frequency</b>	30 kHz
<b>Transverse sensitivity, max</b>	5% of axial
<b>Sensitivity variation with temp:</b>	
-25°C	-10%
+120°C	+10%
<b>Temperature sensor:</b>	
<b>Temperature range</b>	-40°C to +120°C
<b>Voltage range</b>	+2.52 to +0.77 V
<b>Temperature signal sensitivity</b>	-10.9 mV/°C
<b>Voltage at 0°C</b>	+2.1 V
<b>Power requirement:</b>	
<b>Voltage source</b>	3.0 - 5.5 VDC
<b>Current (no cable)</b>	100 µA, max
<b>Electrical noise, equiv. g:</b>	
<b>Broadband</b>	2.5 Hz to 25 kHz
<b>Spectral</b>	
10 Hz	660 µg
100 Hz	60 µg/√Hz
1,000 Hz	16 µg/√Hz
	5 µg/√Hz
<b>Output impedance, max</b>	1,000 Ω
<b>Bias output voltage, settling time, 25°C</b>	<10 ms
<b>Including temp effects</b>	1.5 VDC ±5%
<b>Grounding</b>	case isolated, internally shielded
<b>Vibration limit</b>	500 g peak
<b>Shock limit</b>	5,000 g peak
<b>Electromagnetic sensitivity, equiv. g, max</b>	150 µg/gauss
<b>Sealing</b>	hermetic
<b>Base strain sensitivity, max</b>	0.0002 g/µstrain
<b>Sensing element design</b>	PZT, shear
<b>Weight</b>	90 grams
<b>Case material</b>	316L stainless steel
<b>Mounting</b>	1/4-28 UNF tapped hole
<b>Mating connector</b>	M12 style, socket
<b>Recommended cabling</b>	J99



### Key features

- 300 µW power consumption
- BOV settling time of <10 ms
- Certified for use in hazardous areas
- Internal temperature sensor
- Manufactured in ISO 9001 facility

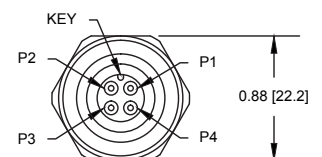
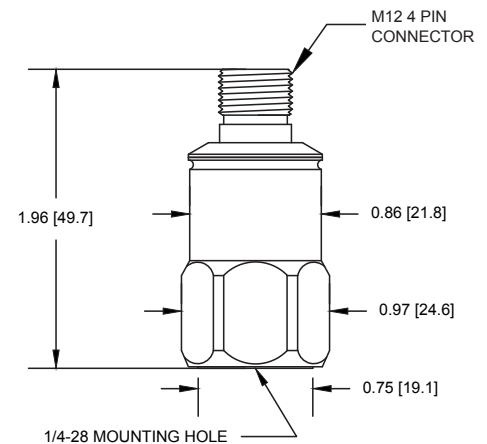

Connections	
Function	Connector pin
power	1
common	2
accel signal	3
temp signal	4
shield*	shell

\*For installations requiring CE conformance, cable shield must be tied to sensor case.

### Certifications

**NOTE:** See reverse for installation requirements.



Class I, Div 2 Groups A, B, C, D  
Class II, Div 2 Groups E, F, G  
Class III; T5  
Ex nL IIC T



II 3 G  
Ex nA nC IIC T5 Gc  
Ex ic IIC T5 Gc  
Ta = -50°C to +85°C



Note: Due to continuous process improvement, specifications are subject to change without notice. This document is cleared for public release.

# Certified low-power, low-voltage accelerometer

## LPA100T-D2



### Hazardous area installation requirements

The mating connection shall be made using an M12 connector in compliance with IEC 61076-2-101. This standard requires that the connectors be kept from separating using a lock nut or threaded sleeve on the mating connection. The M12 connector must have a minimum creepage distance of 1.0 mm between adjacent contacts and a minimum distance of 0.2 mm through the solid insulation between adjacent contacts. The M12 connector must use a socket designed to maintain positive compressive force on the connector pin with a minimum diameter of 0.889 mm and maintain a degree of ingress protection of at least IP54 when mated with the integral plug arrangement provided for the Accelerometer.

The equipment does not incorporate an earth bonding facility. It is the responsibility of the user to ensure that earth continuity is maintained, for example, by means of the mounting arrangement.

To limit the supply current to a maximum of 100  $\mu$ A, both the acceleration output and the temperature output must be connected to input circuits with a minimum impedance of 150,000 ohms.

The 5.5 Vdc rated supply shall be protected such that transients are limited to a maximum of 90 Vdc.

A degree of ingress protection of at least IP54 shall be maintained even when the cable connector is removed, for example by means of the fitting of a suitable cap.

### Conditions for type protection Ex ic IIC T5 Gc installations:

The monitoring equipment must have an input impedance of at least 150,000 ohms for both the accelerometer and the temperature signals.

The cable installed must be suitable for the installation temperature and the voltage of any intermingled circuits.

Where the installation requires that the Accelerometer enclosure be grounded, this is to be done using a metal mounting stud as described in document 78013.

Note: Due to continuous process improvement, specifications are subject to change without notice. This document is cleared for public release.



Компания «ЭлектроПласт» предлагает заключение долгосрочных отношений при поставках импортных электронных компонентов на взаимовыгодных условиях!

Наши преимущества:

- Оперативные поставки широкого спектра электронных компонентов отечественного и импортного производства напрямую от производителей и с крупнейших мировых складов;
- Поставка более 17-ти миллионов наименований электронных компонентов;
- Поставка сложных, дефицитных, либо снятых с производства позиций;
- Оперативные сроки поставки под заказ (от 5 рабочих дней);
- Экспресс доставка в любую точку России;
- Техническая поддержка проекта, помощь в подборе аналогов, поставка прототипов;
- Система менеджмента качества сертифицирована по Международному стандарту ISO 9001;
- Лицензия ФСБ на осуществление работ с использованием сведений, составляющих государственную тайну;
- Поставка специализированных компонентов (Xilinx, Altera, Analog Devices, Intersil, Interpoint, Microsemi, Aeroflex, Peregrine, Syfer, Eurofarad, Texas Instrument, Miteq, Cobham, E2V, MA-COM, Hittite, Mini-Circuits, General Dynamics и др.);

Помимо этого, одним из направлений компании «ЭлектроПласт» является направление «Источники питания». Мы предлагаем Вам помощь Конструкторского отдела:

- Подбор оптимального решения, техническое обоснование при выборе компонента;
- Подбор аналогов;
- Консультации по применению компонента;
- Поставка образцов и прототипов;
- Техническая поддержка проекта;
- Защита от снятия компонента с производства.



#### Как с нами связаться

**Телефон:** 8 (812) 309 58 32 (многоканальный)

**Факс:** 8 (812) 320-02-42

**Электронная почта:** [org@eplast1.ru](mailto:org@eplast1.ru)

**Адрес:** 198099, г. Санкт-Петербург, ул. Калинина, дом 2, корпус 4, литера А.