

2.5 x 2.0 x 1.2mm BUILT-IN CAPACITANCE CERAMIC RESONATOR



2.5 x 2.0 x 1.2mm

AWSCR-CW

Pb in ceramic
(exempt per RoHS 2002/95/EC Annex (7))

RoHS
Compliant

FEATURES:

- Low resonant impedance
- Built-in load capacitors
- IR reflow capable

APPLICATIONS:

- Remote controls, Microprocessor clocks, Mobile phones, DVD & CD-Roms, Electric appliances, Industrial controllers
- Consumer electronics

STANDARD SPECIFICATIONS:

Item	Requirement
Frequency Range	20.00MHz to 48.00 MHz
Resonant Impedance	See Table 2.1
Frequency Tolerance	± 0.5% (at 25°C)
Frequency stability	±0.2% (-25°C~+85°C) max*
Withstanding Voltage (V)	50 (DC , 1 min)
Rating Voltage	
(1) D.C. Voltage	6 V DC max
(2) A.C. Voltage	15 Vp-p. max
Built-in Capacitance (C1=C2)	10pF± 20% (20.00 to 25.99 MHz) 5pF± 20% (26.00 to 48.00 MHz)
Insulation Resistance	100MΩ min. (10V, 1min)
Operating Temperature	-25°C to +85°C*
Storage Temperature	-55°C to +85°C
Aging Rate (Fosc)	±0.2% max. (From initial value)

Table 2.1

Frequency range (MHz)	Resonant Impedance (Ro)(Ω) max
20.00 MHz - 25.99 MHz	60
26.00 MHz - 35.00 MHz	50
35.01 MHz - 48.00 MHz	50

* Please contact ABRACON for tighter stability and/or wider temperature range

TEST CIRCUIT:

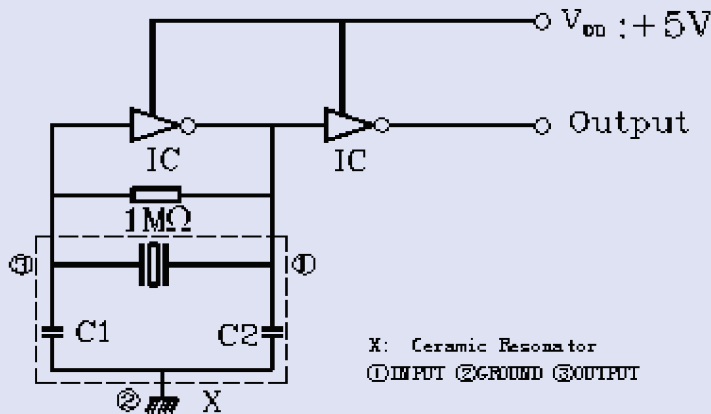

OPTIONS AND PART IDENTIFICATION:

AWSCR - XX.XXCW - C□□ - □

Frequency
Frequency in MHz

Load Capacitance
Contact ABRACON for Load Capacitance options

Packaging
T for Tape and Reel

2.5 x 2.0 x 1.2mm BUILT-IN CAPACITANCE CERAMIC RESONATOR



2.5 x 2.0 x 1.2mm

AWSCR-CW

Pb in ceramic
(exempt per RoHS 2002/95/EC Annex (7))

RoHS
Compliant

OUTLINE DRAWING:

Dimensions: mm

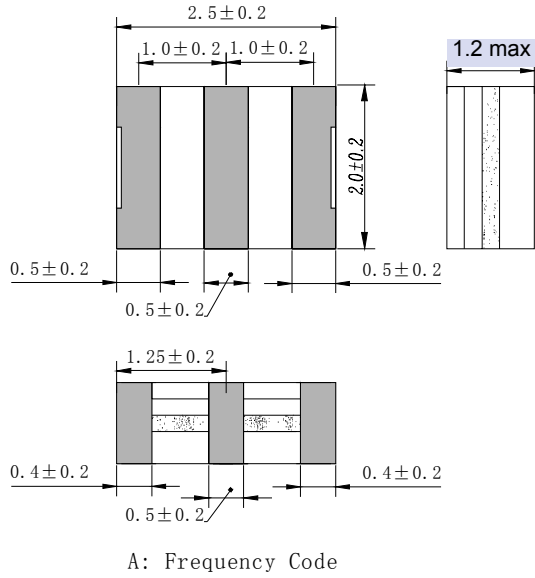

RECOMMENDED LAND PATTERN

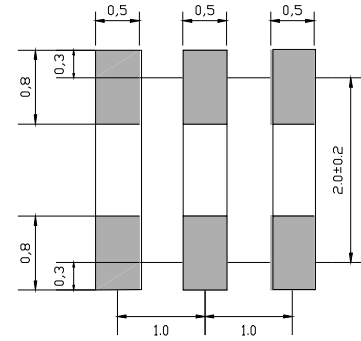

TAPE & REEL:

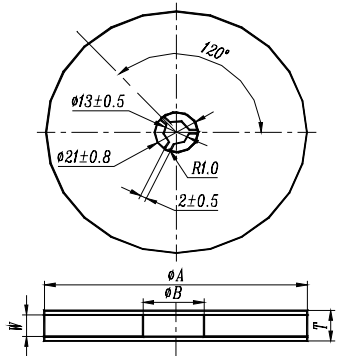

ϕA	ϕB	W	T	Pieces per reel	Carrier tape size
180 ± 3	60min	8.4min	12.4max	3000typ.	8

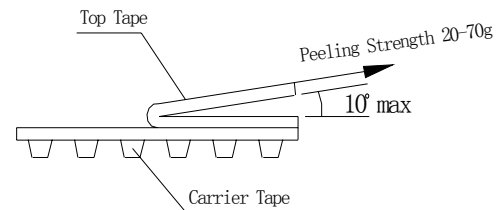
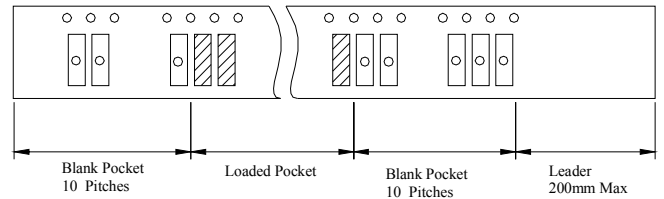

Dimension : mm

2.5 x 2.0 x 1.2mm BUILT-IN CAPACITANCE CERAMIC RESONATOR



AWSCR-CW

Pb in ceramic
(exempt per RoHS 2002/95/EC Annex (7))

RoHS
Compliant

2.5 x 2.0 x 1.2mm

REFLOW PROFILE:

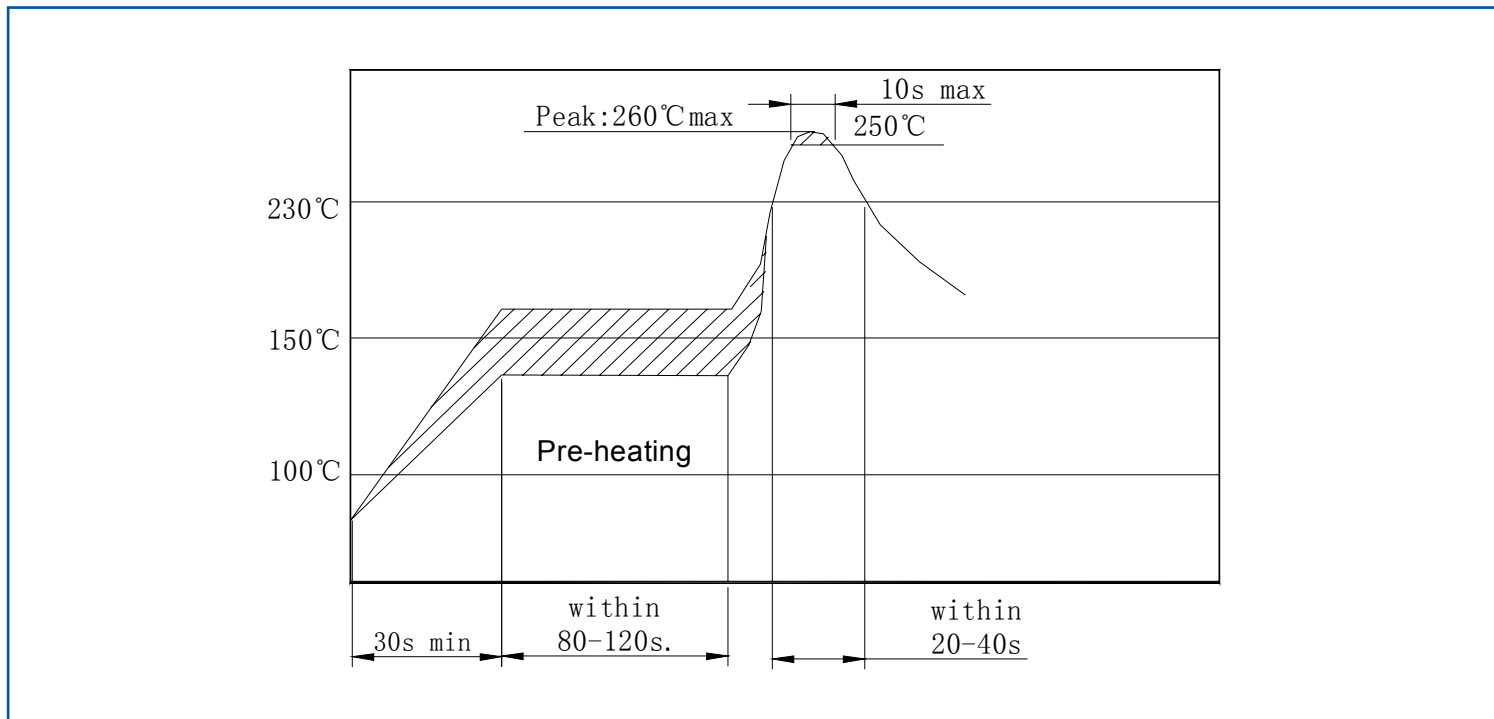

CAUTION

- Do not apply excess mechanical stress to the component body or terminations. Do not attempt to re-form or bend the components as this will cause damage to the component.
- This component is not hermetically sealed. Do not clean or wash the component.
- Reflow soldering: Do not use strong acidity flux, such as flux with chlorine content of greater than 0.2wt% during reflow Soldering.
- Do not expose the component to open flame.
- This specification applies to the functionality of the component as a single unit. Customers are advised to insure that the component is thoroughly evaluated in the particular application.
- Shelf life: The warranted shelf life of this product is six months after the delivery date under the conditions of sealed, unopened, original packaging.
- Storage conditions: If the product is to be stored for a period greater than six months after the delivery date, it is recommended that customers confirm the solderability and characteristics for the product prior to use.
- This product is not recommended for use in the following applications: Automotive, Medical, Military, Safety, or any other high-reliability, life-dependant application. Contact Abracon Corporation prior to using this product when in doubt.

ATTENTION: Abracon Corporation's products are COTS – Commercial-Off-The-Shelf products; suitable for Commercial, Industrial and, where designated, Automotive Applications. Abracon's products are not specifically designed for Military, Aviation, Aerospace, Life-dependant Medical applications or any application requiring high reliability where component failure could result in loss of life and/or property. For applications requiring high reliability and/or presenting an extreme operating environment, written consent and authorization from Abracon Corporation is required. Please contact Abracon Corporation for more information.

ABRACON IS
ISO9001:2008
CERTIFIED



Visit www.abracon.com for Terms & Conditions of Sale **Revised: 09.12.10**
30332 Esperanza, Rancho Santa Margarita, California 92688
tel 949-546-8000 | fax 949-546-8001 | www.abracon.com



Компания «ЭлектроПласт» предлагает заключение долгосрочных отношений при поставках импортных электронных компонентов на взаимовыгодных условиях!

Наши преимущества:

- Оперативные поставки широкого спектра электронных компонентов отечественного и импортного производства напрямую от производителей и с крупнейших мировых складов;
- Поставка более 17-ти миллионов наименований электронных компонентов;
- Поставка сложных, дефицитных, либо снятых с производства позиций;
- Оперативные сроки поставки под заказ (от 5 рабочих дней);
- Экспресс доставка в любую точку России;
- Техническая поддержка проекта, помощь в подборе аналогов, поставка прототипов;
- Система менеджмента качества сертифицирована по Международному стандарту ISO 9001;
- Лицензия ФСБ на осуществление работ с использованием сведений, составляющих государственную тайну;
- Поставка специализированных компонентов (Xilinx, Altera, Analog Devices, Intersil, Interpoint, Microsemi, Aeroflex, Peregrine, Syfer, Eurofarad, Texas Instrument, Miteq, Cobham, E2V, MA-COM, Hittite, Mini-Circuits, General Dynamics и др.);

Помимо этого, одним из направлений компании «ЭлектроПласт» является направление «Источники питания». Мы предлагаем Вам помощь Конструкторского отдела:

- Подбор оптимального решения, техническое обоснование при выборе компонента;
- Подбор аналогов;
- Консультации по применению компонента;
- Поставка образцов и прототипов;
- Техническая поддержка проекта;
- Защита от снятия компонента с производства.



Как с нами связаться

Телефон: 8 (812) 309 58 32 (многоканальный)

Факс: 8 (812) 320-02-42

Электронная почта: org@eplast1.ru

Адрес: 198099, г. Санкт-Петербург, ул. Калинина, дом 2, корпус 4, литера А.