



RLDRAM 3

IS49RL18320– 2 Meg x 18 x 16 Banks

IS49RL36160– 1 Meg x 36 x 16 Banks

Features

- 1066 MHz DDR operation (2133 Mb/s/ball data rate)
- 76.8 Gb/s peak bandwidth (x36 at 1066 MHz clock frequency)
- Organization
 - 32 Meg x 18, and 16 Meg x 36 common I/O (CIO)
 - 16 banks
- 1.2V center-terminated push/pull I/O
- 2.5V V_{EXT}, 1.35V V_{DD}, 1.2V V_{DDQ} I/O
- Reduced cycle time (t_{RC} (MIN) = 8 - 12ns)
- SDR addressing
- Programmable READ/WRITE latency (RL/WL) and burst length
- Data mask for WRITE commands
- Differential input clocks (CK, CK#)
- Free-running differential input data clocks (DK x, DK x#) and output data clocks (QK x, QK x#)
- On-die DLL generates CK edge-aligned data and differential output data clock signals
- 64ms refresh (128K refresh per 64ms)
- 168-ball FBGA package
- 40Ω or 60Ω matched impedance outputs
- Integrated on-die termination (ODT)
- Single or multibank writes
- Extended operating range (200–1066 MHz)
- READ training register
- Multiplexed and non-multiplexed addressing capabilities
- Mirror function
- Output driver and ODT calibration
- JTAG interface (IEEE 1149.1-2001)

Options

- Clock cycle and t_{RC} timing
 - 0.93ns and t_{RC} (MIN) = 8ns (RL3-2133)
 - 0.93ns and t_{RC} (MIN) = 10ns (RL3-2133)
 - 1.07ns and t_{RC} (MIN) = 8ns (RL3-1866)
 - 1.07ns and t_{RC} (MIN) = 10ns (RL3-1866)
 - 1.25ns and t_{RC} (MIN) = 8ns (RL3-1600)
 - 1.25ns and t_{RC} (MIN) = 10ns (RL3-1600)
 - 1.25ns and t_{RC} (MIN) = 12ns (RL3-1600)
- Configuration
 - 32 Meg x 18
 - 16 Meg x 36
- Operating Temperature
 - Commercial (T_C = 0° to +95°C)
 - Industrial (T_C = –40°C to +95°C)
- Package
 - 168-ball FBGA
 - 168-ball FBGA (Pb-free)
- Revision

Copyright © 2014 Integrated Silicon Solution, Inc. All rights reserved. ISSI reserves the right to make changes to this specification and its products at any time without notice. ISSI assumes no liability arising out of the application or use of any information, products or services described herein. Customers are advised to obtain the latest version of this device specification before relying on any published information and before placing orders for product

Integrated Silicon Solution, Inc. does not recommend the use of any of its products in life support applications where the failure or malfunction of the product can reasonably be expected to cause failure of the life support system or to significantly affect its safety or effectiveness. Products are not authorized for use in such applications unless Integrated Silicon Solution, Inc. receives written assurance to its satisfaction, that:

- a.) the risk of injury or damage has been minimized;
- b.) the user assume all such risks; and
- c.) potential liability of Integrated Silicon Solution, Inc is adequately protected under the circumstances

RLDRAM® is a registered trademark of Micron Technology, Inc.

Figure 1: 576Mb RLD RAM 3 Part Numbers

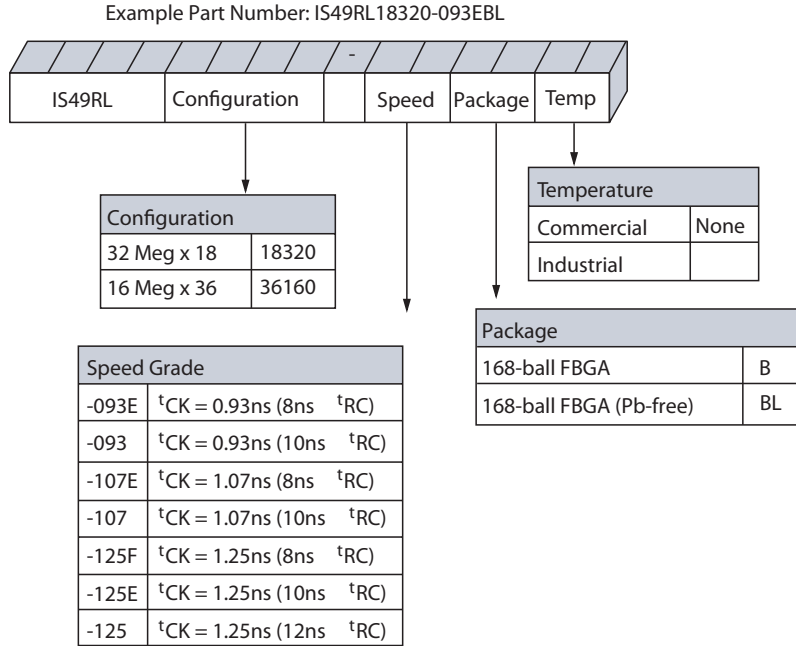

BGA Part Marking Decoder

Due to space limitations, BGA-packaged components have an abbreviated part marking that is different from the part number. ISSI'S BGA Part Marking Decoder is available on ISSI'S Web site at www.issi.com



Contents

| | |
|--|----|
| General Description | 8 |
| General Notes | 8 |
| State Diagram | 9 |
| Functional Block Diagrams | 10 |
| Ball Assignments and Descriptions | 12 |
| Package Dimensions | 16 |
| Electrical Characteristics – I _{DD} Specifications | 17 |
| Electrical Specifications – Absolute Ratings and I/O Capacitance | 21 |
| Absolute Maximum Ratings | 21 |
| Input/Output Capacitance | 21 |
| AC and DC Operating Conditions | 22 |
| AC Overshoot/Undershoot Specifications | 24 |
| Slew Rate Definitions for Single-Ended Input Signals | 27 |
| Slew Rate Definitions for Differential Input Signals | 29 |
| ODT Characteristics | 30 |
| ODT Resistors | 30 |
| ODT Sensitivity | 32 |
| Output Driver Impedance | 33 |
| Output Driver Sensitivity | 35 |
| Output Characteristics and Operating Conditions | 36 |
| Reference Output Load | 39 |
| Slew Rate Definitions for Single-Ended Output Signals | 40 |
| Slew Rate Definitions for Differential Output Signals | 41 |
| Speed Bin Tables | 42 |
| AC Electrical Characteristics | 44 |
| Temperature and Thermal Impedance Characteristics | 49 |
| Command and Address Setup, Hold, and Derating | 51 |
| Data Setup, Hold, and Derating | 57 |
| Commands | 63 |
| MODE REGISTER SET (MRS) Command | 64 |
| Mode Register 0 (MR0) | 65 |
| ^t RC | 66 |
| Data Latency | 66 |
| DLL Enable/Disable | 66 |
| Address Multiplexing | 66 |
| Mode Register 1 (MR1) | 68 |
| Output Drive Impedance | 68 |
| DQ On-Die Termination (ODT) | 68 |
| DLL Reset | 68 |
| ZQ Calibration | 69 |
| ZQ Calibration Long | 70 |
| ZQ Calibration Short | 70 |
| AUTO REFRESH Protocol | 71 |
| Burst Length (BL) | 71 |
| Mode Register 2 (MR2) | 73 |
| READ Training Register (RTR) | 73 |
| WRITE Protocol | 75 |
| WRITE Command | 75 |
| Multibank WRITE | 76 |
| READ Command | 76 |



| | |
|---|-----|
| AUTO REFRESH Command | 78 |
| INITIALIZATION Operation | 80 |
| WRITE Operation | 83 |
| READ Operation | 87 |
| AUTO REFRESH Operation | 90 |
| Multiplexed Address Mode | 93 |
| Data Latency in Multiplexed Address Mode | 98 |
| REFRESH Command in Multiplexed Address Mode | 98 |
| Mirror Function | 102 |
| RESET Operation | 102 |
| IEEE 1149.1 Serial Boundary Scan (JTAG) | 103 |
| Disabling the JTAG Feature | 103 |
| Test Access Port (TAP) | 103 |
| TAP Controller | 104 |
| Performing a TAP RESET | 106 |
| TAP Registers | 106 |
| TAP Instruction Set | 107 |
| Revision History | 114 |
| Rev. C, Production – 12/12 | 114 |
| Rev. B, Advance – 1/12 | 114 |
| Rev. A, Advance – 6/11 | 115 |



List of Figures

| | |
|---|----|
| Figure 1: 576Mb RLD RAM [®] 3 Part Numbers | 2 |
| Figure 2: Simplified State Diagram | 9 |
| Figure 3: 32 Meg x 18 Functional Block Diagram | 10 |
| Figure 4: 16 Meg x 36 Functional Block Diagram | 11 |
| Figure 5: 168-Ball FBGA | 16 |
| Figure 6: Single-Ended Input Signal | 23 |
| Figure 7: Overshoot | 24 |
| Figure 8: Undershoot | 24 |
| Figure 9: V _{IX} for Differential Signals | 25 |
| Figure 10: Single-Ended Requirements for Differential Signals | 26 |
| Figure 11: Definition of Differential AC Swing and ^t DVAC | 26 |
| Figure 12: Nominal Slew Rate Definition for Single-Ended Input Signals | 28 |
| Figure 13: Nominal Differential Input Slew Rate Definition for CK, CK#, DKx, and DKx# | 29 |
| Figure 14: ODT Levels and I-V Characteristics | 30 |
| Figure 15: Output Driver | 33 |
| Figure 16: DQ Output Signal | 38 |
| Figure 17: Differential Output Signal | 39 |
| Figure 18: Reference Output Load for AC Timing and Output Slew Rate | 39 |
| Figure 19: Nominal Slew Rate Definition for Single-Ended Output Signals | 40 |
| Figure 20: Nominal Differential Output Slew Rate Definition for QKx, QKx# | 41 |
| Figure 21: Example Temperature Test Point Location | 50 |
| Figure 22: Nominal Slew Rate and ^t VAC for ^t IS (Command and Address - Clock) | 53 |
| Figure 23: Nominal Slew Rate for ^t IH (Command and Address - Clock) | 54 |
| Figure 24: Tangent Line for ^t IS (Command and Address - Clock) | 55 |
| Figure 25: Tangent Line for ^t IH (Command and Address - Clock) | 56 |
| Figure 26: Nominal Slew Rate and ^t VAC for ^t DS (DQ - Strobe) | 59 |
| Figure 27: Nominal Slew Rate for ^t DH (DQ - Strobe) | 60 |
| Figure 28: Tangent Line for ^t DS (DQ - Strobe) | 61 |
| Figure 29: Tangent Line for ^t DH (DQ - Strobe) | 62 |
| Figure 30: MRS Command Protocol | 64 |
| Figure 31: MR0 Definition for Non-Multiplexed Address Mode | 65 |
| Figure 32: MR1 Definition for Non-Multiplexed Address Mode | 68 |
| Figure 33: ZQ Calibration Timing (ZQCL and ZQCS) | 70 |
| Figure 34: Read Burst Lengths | 72 |
| Figure 35: MR2 Definition for Non-Multiplexed Address Mode | 73 |
| Figure 36: READ Training Function - Back-to-Back Readout | 74 |
| Figure 37: WRITE Command | 75 |
| Figure 38: READ Command | 77 |
| Figure 39: Bank Address-Controlled AUTO REFRESH Command | 78 |
| Figure 40: Multibank AUTO REFRESH Command | 79 |
| Figure 41: Power-Up/Initialization Sequence | 81 |
| Figure 42: WRITE Burst | 83 |
| Figure 43: Consecutive WRITE Bursts | 84 |
| Figure 44: WRITE-to-READ | 84 |
| Figure 45: WRITE - DM Operation | 85 |
| Figure 46: Consecutive Quad Bank WRITE Bursts | 86 |
| Figure 47: Interleaved READ and Quad Bank WRITE Bursts | 86 |
| Figure 48: Basic READ Burst | 87 |
| Figure 49: Consecutive READ Bursts (BL = 2) | 88 |
| Figure 50: Consecutive READ Bursts (BL = 4) | 88 |



| | |
|---|-----|
| Figure 51: READ-to-WRITE (BL = 2) | 89 |
| Figure 52: Read Data Valid Window | 89 |
| Figure 53: Bank Address-Controlled AUTO REFRESH Cycle | 90 |
| Figure 54: Multibank AUTO REFRESH Cycle | 90 |
| Figure 55: READ Burst with ODT | 91 |
| Figure 56: READ-NOP-READ with ODT | 92 |
| Figure 57: Command Description in Multiplexed Address Mode | 93 |
| Figure 58: Power-Up/Initialization Sequence in Multiplexed Address Mode | 94 |
| Figure 59: MR0 Definition for Multiplexed Address Mode | 95 |
| Figure 60: MR1 Definition for Multiplexed Address Mode | 96 |
| Figure 61: MR2 Definition for Multiplexed Address Mode | 97 |
| Figure 62: Bank Address-Controlled AUTO REFRESH Operation with Multiplexed Addressing | 98 |
| Figure 63: Multibank AUTO REFRESH Operation with Multiplexed Addressing | 98 |
| Figure 64: Consecutive WRITE Bursts with Multiplexed Addressing | 99 |
| Figure 65: WRITE-to-READ with Multiplexed Addressing | 100 |
| Figure 66: Consecutive READ Bursts with Multiplexed Addressing | 100 |
| Figure 67: READ-to-WRITE with Multiplexed Addressing | 101 |
| Figure 68: TAP Controller State Diagram | 105 |
| Figure 69: TAP Controller Functional Block Diagram | 105 |
| Figure 70: JTAG Operation - Loading Instruction Code and Shifting Out Data | 108 |
| Figure 71: TAP Timing | 109 |



List of Tables

| | |
|--|-----|
| Table 1: 32 Meg x 18 Ball Assignments – 168-Ball FBGA (Top View) | 12 |
| Table 2: 16 Meg x 36 Ball Assignments – 168-Ball FBGA (Top View) | 13 |
| Table 3: Ball Descriptions | 14 |
| Table 4: I _{DD} Operating Conditions and Maximum Limits | 17 |
| Table 5: Absolute Maximum Ratings | 21 |
| Table 6: Input/Output Capacitance | 21 |
| Table 7: DC Electrical Characteristics and Operating Conditions..... | 22 |
| Table 8: Input AC Logic Levels | 22 |
| Table 9: Control and Address Balls | 24 |
| Table 10: Clock, Data, Strobe, and Mask Balls | 24 |
| Table 11: Differential Input Operating Conditions (CK, CK# and DK _x , DK _x #) | 25 |
| Table 12: Allowed Time Before Ringback (t _{DVAC}) for CK, CK#, DK _x , and DK _x # | 27 |
| Table 13: Single-Ended Input Slew Rate Definition | 27 |
| Table 14: Differential Input Slew Rate Definition | 29 |
| Table 15: ODT DC Electrical Characteristics | 30 |
| Table 16: R _{TT} Effective Impedances | 31 |
| Table 17: ODT Sensitivity Definition | 32 |
| Table 18: ODT Temperature and Voltage Sensitivity | 32 |
| Table 19: Driver Pull-Up and Pull-Down Impedance Calculations | 34 |
| Table 20: Output Driver Sensitivity Definition | 35 |
| Table 21: Output Driver Voltage and Temperature Sensitivity | 35 |
| Table 22: Single-Ended Output Driver Characteristics | 36 |
| Table 23: Differential Output Driver Characteristics | 37 |
| Table 24: Single-Ended Output Slew Rate Definition | 40 |
| Table 25: Differential Output Slew Rate Definition | 41 |
| Table 26: RL3 2133/1866 Speed Bins | 42 |
| Table 27: RL3 1600 Speed Bins | 43 |
| Table 28: AC Electrical Characteristics | 44 |
| Table 29: Temperature Limits | 49 |
| Table 30: Thermal Impedance | 49 |
| Table 31: Command and Address Setup and Hold Values Referenced at 1 V/ns – AC/DC-Based | 51 |
| Table 32: Derating Values for t _{IS} / t _{IH} – AC150/DC100-Based | 52 |
| Table 33: Minimum Required Time t _{VAC} Above V _{IH(AC)} (or Below V _{IL(AC)}) for Valid Transition..... | 52 |
| Table 34: Data Setup and Hold Values at 1 V/ns (DK _x , DK _x # at 2V/ns) – AC/DC-Based | 57 |
| Table 35: Derating Values for t _{DS} / t _{DH} – AC150/DC100-Based..... | 58 |
| Table 36: Minimum Required Time t _{VAC} Above V _{IH(AC)} (or Below V _{IL(AC)}) for Valid Transition..... | 58 |
| Table 37: Command Descriptions | 63 |
| Table 38: Command Table | 63 |
| Table 39: t _{RC_MRS} MR0[3:0] values | 66 |
| Table 40: Address Widths of Different Burst Lengths..... | 71 |
| Table 41: Address Mapping in Multiplexed Address Mode | 97 |
| Table 42: 32 Meg x 18 Ball Assignments with MF Ball Tied HIGH | 102 |
| Table 43: TAP Input AC Logic Levels | 109 |
| Table 44: TAP AC Electrical Characteristics | 109 |
| Table 45: TAP DC Electrical Characteristics and Operating Conditions..... | 110 |
| Table 46: Identification Register Definitions | 110 |
| Table 47: Scan Register Sizes | 111 |
| Table 48: Instruction Codes | 111 |
| Table 49: Boundary Scan (Exit) | 111 |
| Table 50: Ordering information | 113 |



General Description

The ISSI® RLDRAM® 3 is a high-speed memory device designed for high-bandwidth data storage—telecommunications, networking, cache applications, etc. The chip's 16-bank architecture is optimized for sustainable high-speed operation.

The DDR I/O interface transfers two data bits per clock cycle at the I/O balls. Output data is referenced to the READ strobes.

Commands, addresses, and control signals are also registered at every positive edge of the differential input clock, while input data is registered at both positive and negative edges of the input data strobes.

Read and write accesses to the RL3 device are burst-oriented. The burst length (BL) is programmable to 2, 4, or 8 by a setting in the mode register.

The device is supplied with 1.35V for the core and 1.2V for the output drivers. The 2.5V supply is used for an internal supply.

Bank-scheduled refresh is supported with the row address generated internally.

The 168-ball FBGA package is used to enable ultra-high-speed data transfer rates.

General Notes

- The functionality and the timing specifications discussed in this data sheet are for the DLL enable mode of operation.
- Any functionality not specifically stated is considered undefined, illegal, and not supported, and can result in unknown operation.
- Nominal conditions are assumed for specifications not defined within the figures shown in this data sheet.
- Throughout this data sheet, the terms "RLDRAM," "DRAM," and "RLDRAM 3" are all used interchangeably and refer to the RLDRAM 3 SDRAM device.
- References to DQ, DK, QK, DM, and QVLD are to be interpreted as each group collectively, unless specifically stated otherwise. This includes true and complement signals of differential signals.
- Non-multiplexed operation is assumed if not specified as multiplexed.
- A X36 Device supplies four QK/QK# sets. One per 9 DQs. If a user only wants to use two QK/QK# sets, this is allowed. The user needs to use QK0/QK0# and QK1/QK1#. QK0/QK0# will control DQ[8:0] & DQ[26:18]. QK1/QK1# will control DQ[17:9] & DQ[35:27]. The QK to DQ timing parameter to be used would be t_{QKQ02} , t_{QKQ13} . The unused QK/QK# pins should be left floating.

State Diagram

Figure 2: Simplified State Diagram

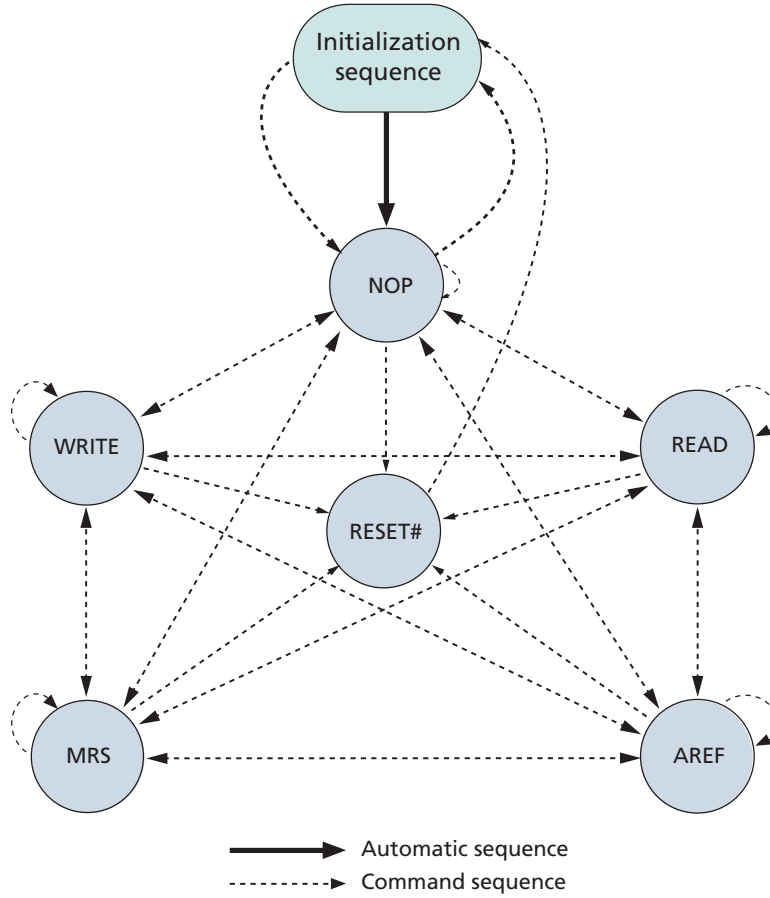

Functional Block Diagrams

Figure 3: 32 Meg x 18 Functional Block Diagram

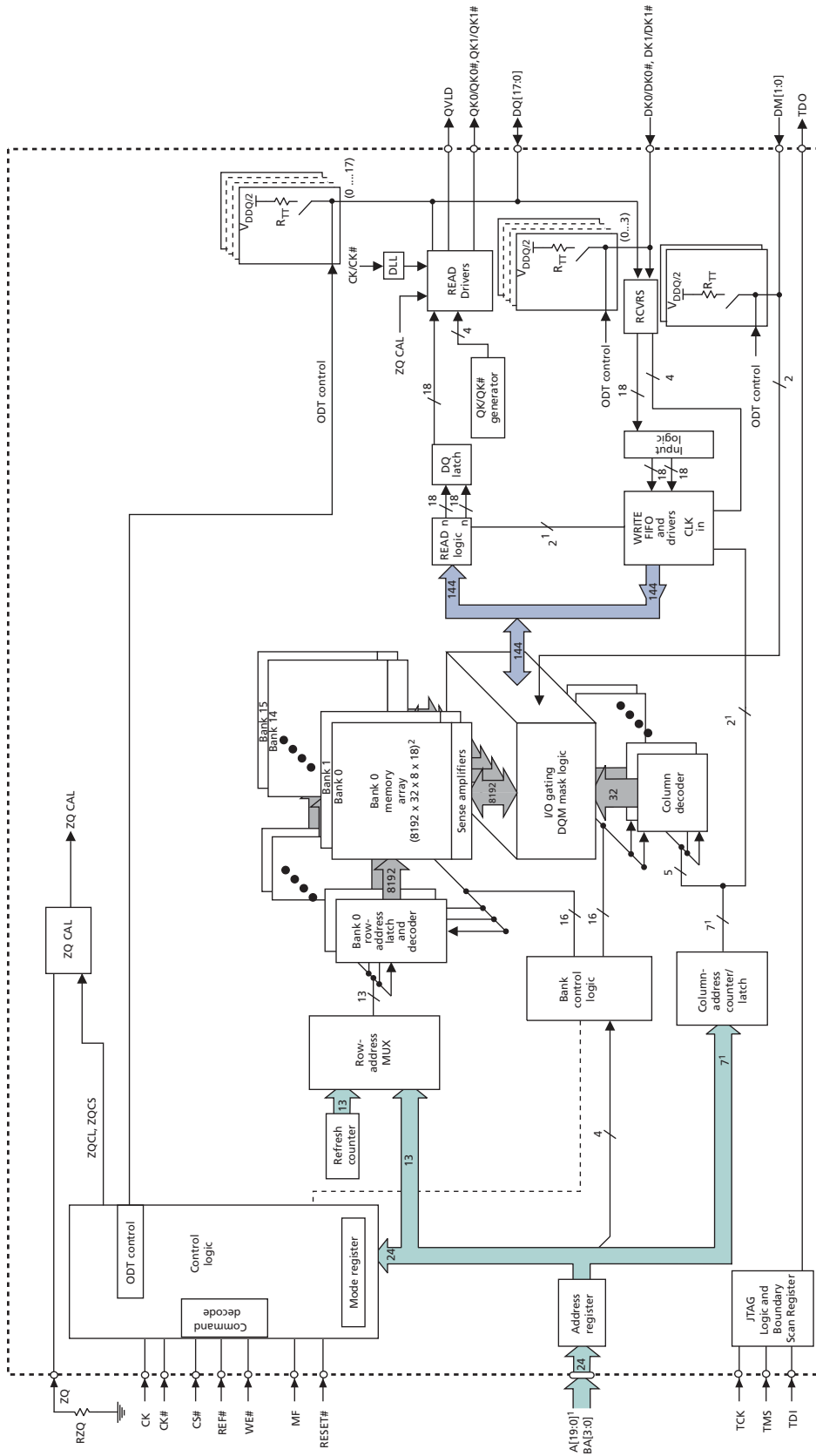

- Notes:
1. Example for BL = 2; column address will be reduced with an increase in burst length.
 2. $8 = (\text{length of burst}) \times 2^{\wedge} (\text{number of column addresses to WRITE FIFO and READ logic})$.

Functional Block Diagrams

Figure 4: 16 Meg x 36 Functional Block Diagram

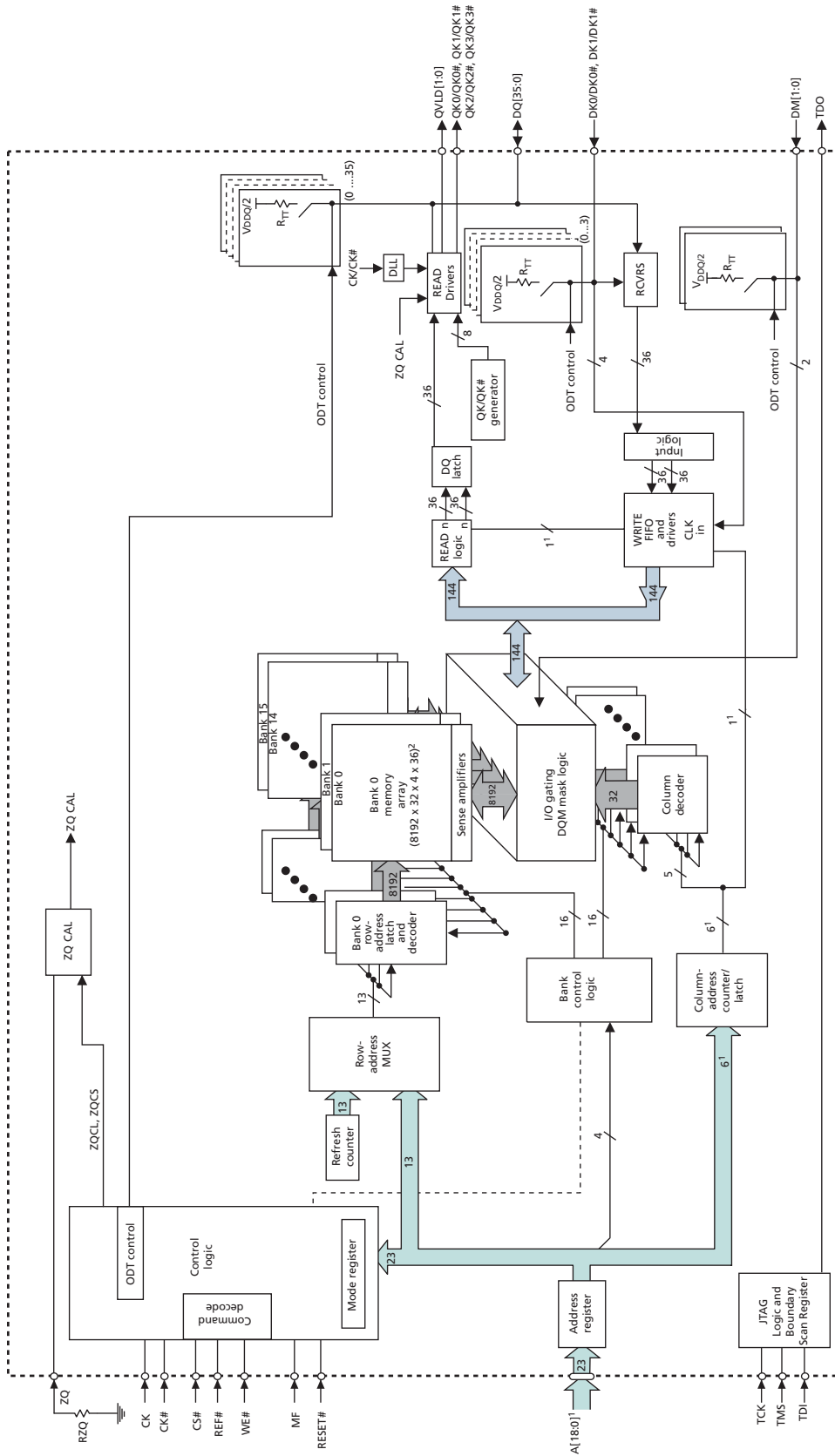

- Notes:
1. Example for BL = 2; column address will be reduced with an increase in burst length.
 2. 4 = (length of burst) x 2ⁿ (number of column addresses to WRITE FIFO and READ logic).



Ball Assignments and Descriptions

Table 1: 32 Meg x 18 Ball Assignments – 168-Ball FBGA (Top View)

| | 1 | 2 | 3 | 4 | 5 | 6 | 7 | 8 | 9 | 10 | 11 | 12 | 13 |
|----------|-----------------------------------|----------------------------------|------------------|------------------|------------------|------------------|------------------|------------------|------------------|------------------|------------------|------------------|-----------------------------------|
| A | | V _{SS} | V _{DD} | NF | V _{DDQ} | NF | V _{REF} | DQ7 | V _{DDQ} | DQ8 | V _{DD} | V _{SS} | RESET# |
| B | V _{EXT} | V _{SS} | NF | V _{SSQ} | NF | V _{DDQ} | DM0 | V _{DDQ} | DQ5 | V _{SSQ} | DQ6 | V _{SS} | V _{EXT} |
| C | V _{DD} | NF | V _{DDQ} | NF | V _{SSQ} | NF | DK0# | DQ2 | V _{SSQ} | DQ3 | V _{DDQ} | DQ4 | V _{DD} |
| D | A11 | V _{SSQ} | NF | V _{DDQ} | NF | V _{SSQ} | DK0 | V _{SSQ} | QK0 | V _{DDQ} | DQ0 | V _{SSQ} | A13 |
| E | V _{SS} | A0 | V _{SSQ} | NF | V _{DDQ} | NF | MF | QK0# | V _{DDQ} | DQ1 | V _{SSQ} | CS# | V _{SS} |
| F | A7 | NF _(CS1) ¹ | V _{DD} | A2 | A1 | WE# | ZQ | REF# | A3 | A4 | V _{DD} | A5 | A9 |
| G | V _{SS(A20)} ¹ | A15 | A6 | V _{SS} | BA1 | V _{SS} | CK# | V _{SS} | BA0 | V _{SS} | A8 | A18 | V _{SS(A21)} ¹ |
| H | A19 | V _{DD} | A14 | A16 | V _{DD} | BA3 | CK | BA2 | V _{DD} | A17 | A12 | V _{DD} | A10 |
| J | V _{DDQ} | NF | V _{SSQ} | NF | V _{DDQ} | NF | V _{SS} | QK1# | V _{DDQ} | DQ9 | V _{SSQ} | QVLD | V _{DDQ} |
| K | NF | V _{SSQ} | NF | V _{DDQ} | NF | V _{SSQ} | DK1 | V _{SSQ} | QK1 | V _{DDQ} | DQ10 | V _{SSQ} | DQ11 |
| L | V _{DD} | NF | V _{DDQ} | NF | V _{SSQ} | NF | DK1# | DQ12 | V _{SSQ} | DQ13 | V _{DDQ} | DQ14 | V _{DD} |
| M | V _{EXT} | V _{SS} | NF | V _{SSQ} | NF | V _{DDQ} | DM1 | V _{DDQ} | DQ15 | V _{SSQ} | DQ16 | V _{SS} | V _{EXT} |
| N | V _{SS} | TCK | V _{DD} | TDO | V _{DDQ} | NF | V _{REF} | DQ17 | V _{DDQ} | TDI | V _{DD} | TMS | V _{SS} |

- Notes:
1. F2 is the Location of the extra CS (CS1) needed to support the x18 DDP device. G1 & G13 are the locations of the additional address signals (A20 & A21 respectfully) needed to support the 2Gb monolithic device. F2 is Internally connected and will mirror the A5 address signal when MF is asserted HIGH and has parasitic characteristics of an address pin. G1 & G13 are VSS pins for this device, but have been designated as the location of A20 & A21 for the future 2Gb device.
 2. NF balls for the x18 configuration are internally connected and have parasitic characteristics of an I/O. Balls may be connected to V_{SSQ}.
 3. MF is assumed to be tied LOW for this ball assignment.



576Mb: x18, x36 RLD RAM 3 Ball Assignments and Descriptions

Table 2: 16 Meg x 36 Ball Assignments – 168-Ball FBGA (Top View)

| | 1 | 2 | 3 | 4 | 5 | 6 | 7 | 8 | 9 | 10 | 11 | 12 | 13 |
|----------|-----------------------------------|----------------------------------|------------------|------------------|------------------|------------------|------------------|------------------|------------------|------------------|------------------|------------------|-----------------------------------|
| A | | V _{SS} | V _{DD} | DQ26 | V _{DDQ} | DQ25 | V _{REF} | DQ7 | V _{DDQ} | DQ8 | V _{DD} | V _{SS} | RESET# |
| B | V _{EXT} | V _{SS} | DQ24 | V _{SSQ} | DQ23 | V _{DDQ} | DM0 | V _{DDQ} | DQ5 | V _{SSQ} | DQ6 | V _{SS} | V _{EXT} |
| C | V _{DD} | DQ22 | V _{DDQ} | DQ21 | V _{SSQ} | DQ20 | DK0# | DQ2 | V _{SSQ} | DQ3 | V _{DDQ} | DQ4 | V _{DD} |
| D | A11 | V _{SSQ} | DQ18 | V _{DDQ} | QK2 | V _{SSQ} | DK0 | V _{SSQ} | QK0 | V _{DDQ} | DQ0 | V _{SSQ} | A13 |
| E | V _{SS} | A0 | V _{SSQ} | DQ19 | V _{DDQ} | QK2# | MF | QK0# | V _{DDQ} | DQ1 | V _{SSQ} | CS# | V _{SS} |
| F | A7 | NF _(CS1) ¹ | V _{DD} | A2 | A1 | WE# | ZQ | REF# | A3 | A4 | V _{DD} | A5 | A9 |
| G | V _{SS(A20)} ¹ | A15 | A6 | V _{SS} | BA1 | V _{SS} | CK# | V _{SS} | BA0 | V _{SS} | A8 | A18 | V _{SS(A21)} ¹ |
| H | NF _(A19) ² | V _{DD} | A14 | A16 | V _{DD} | BA3 | CK | BA2 | V _{DD} | A17 | A12 | V _{DD} | A10 |
| J | V _{DDQ} | QVLD1 | V _{SSQ} | DQ27 | V _{DDQ} | QK3# | V _{SS} | QK1# | V _{DDQ} | DQ9 | V _{SSQ} | QVLD0 | V _{DDQ} |
| K | DQ29 | V _{SSQ} | DQ28 | V _{DDQ} | QK3 | V _{SSQ} | DK1 | V _{SSQ} | QK1 | V _{DDQ} | DQ10 | V _{SSQ} | DQ11 |
| L | V _{DD} | DQ32 | V _{DDQ} | DQ31 | V _{SSQ} | DQ30 | DK1# | DQ12 | V _{SSQ} | DQ13 | V _{DDQ} | DQ14 | V _{DD} |
| M | V _{EXT} | V _{SS} | DQ34 | V _{SSQ} | DQ33 | V _{DDQ} | DM1 | V _{DDQ} | DQ15 | V _{SSQ} | DQ16 | V _{SS} | V _{EXT} |
| N | V _{SS} | TCK | V _{DD} | TDO | V _{DDQ} | DQ35 | V _{REF} | DQ17 | V _{DDQ} | TDI | V _{DD} | TMS | V _{SS} |

- Notes:
1. F2 is the Location of the extra CS (CS1) needed to support the x18 DDP device. G1 & G13 are the locations of the additional address signals (A20 & A21 respectfully) needed to support the 2Gb monolithic device. F2 is Internally connected so it can mirror the A5 address signal when MF is asserted HIGH and has parasitic characteristics of an address pin. G1 & G13 are just place holders for the future device.
 2. NF ball for x36 configuration is internally connected and has parasitic characteristics of an address (A19 for x18 configuration). Ball may be connected to V_{SSQ}.
 3. MF is assumed to be tied LOW for this ball assignment.



Table 3: Ball Descriptions

| Symbol | Type | Description |
|-----------|--------|---|
| A[19:0] | Input | Address inputs: A[19:0] define the row and column addresses for READ and WRITE operations. During a MODE REGISTER SET, the address inputs define the register settings along with BA[3:0]. They are sampled at the rising edge of CK. |
| BA[3:0] | Input | Bank address inputs: Select the internal bank to which a command is being applied. |
| CK/CK# | Input | Input clock: CK and CK# are differential input clocks. Addresses and commands are latched on the rising edge of CK. |
| CS# | Input | Chip select: CS# enables the command decoder when LOW and disables it when HIGH. When the command decoder is disabled, new commands are ignored, but internal operations continue. |
| DQ[35:0] | I/O | Data input: The DQ signals form the 36-bit data bus. During READ commands, the data is referenced to both edges of QK. During WRITE commands, the data is sampled at both edges of DK. |
| DKx, DKx# | Input | Input data clock: DKx and DKx# are differential input data clocks. All input data is referenced to both edges of DKx. For the x36 device, DQ[8:0] and DQ[26:18] are referenced to DK0 and DK0#, and DQ[17:9] and DQ[35:27] are referenced to DK1 and DK1#. For the x18 device, DQ[8:0] are referenced to DK0 and DK0#, and DQ[17:9] are referenced to DK1 and DK1#. DKx and DKx# are free-running signals and must always be supplied to the device. |
| DM[1:0] | Input | Input data mask: DM is the input mask signal for WRITE data. Input data is masked when DM is sampled HIGH. DM0 is used to mask the lower byte for the x18 device and DQ[8:0] and DQ[26:18] for the x36 device. DM1 is used to mask the upper byte for the x18 device and DQ[17:9] and DQ[35:27] for the x36 device. Tie DM[1:0] to V _{SS} if not used. |
| TCK | Input | IEEE 1149.1 clock input: This ball must be tied to V _{SS} if the JTAG function is not used. |
| TMS, TDI | Input | IEEE 1149.1 test inputs: These balls may be left as no connects if the JTAG function is not used. |
| WE#, REF# | Input | Command inputs: Sampled at the positive edge of CK, WE# and REF# (together with CS#) define the command to be executed. |
| RESET# | Input | Reset: RESET# is an active LOW CMOS input referenced to V _{SS} . RESET# assertion and deassertion are asynchronous. RESET# is a CMOS input defined with DC HIGH $\geq 0.8 \times V_{DD}$ and DC LOW $\leq 0.2 \times V_{DDQ}$. |
| ZQ | Input | External impedance: This signal is used to tune the device's output impedance and ODT. RZQ needs to be 240 Ω , where RZQ is a resistor from this signal to ground. |
| QKx, QKx# | Output | Output data clocks: QK and QK# are opposite-polarity output data clocks. They are free-running signals and during READ commands are edge-aligned with the DQs. For the x36 device, QK0, QK0# align with DQ[8:0]; QK1, QK1# align with DQ[17:9]; QK2, QK2# align with DQ[26:18]; QK3, QK3# align with DQ[35:27]. For the x18 device, QK0, QK0# align with DQ[8:0]; QK1, QK1# align with DQ[17:9]. |
| QVLDx | Output | Data valid: The QVLD ball indicates that valid output data will be available on the subsequent rising clock edge. There is a single QVLD ball for the x18 device and two, QVLD0 and QVLD1, for the x36 device. QVLD0 aligns with DQ[17:0]; QVLD1 aligns with DQ[35:18]. |
| MF | Input | Mirror function: The mirror function ball is a DC input used to create mirrored ballouts for simple dual-loaded clamshell mounting. If the ball is tied to V _{SS} , the address and command balls are in their true layout. If the ball is tied to V _{DDQ} , they are in the complement location. MF must be tied HIGH or LOW and cannot be left floating. MF is a CMOS input defined with DC HIGH $\geq 0.8 \times V_{DD}$ and DC LOW $\leq 0.2 \times V_{DDQ}$. |



Table 3: Ball Descriptions (Continued)

| Symbol | Type | Description |
|------------------|--------|--|
| TDO | Output | IEEE 1149.1 test output: JTAG output. This ball may be left as no connect if the JTAG function is not used. |
| V _{DD} | Supply | Power supply: 1.35V nominal. See Table 7 (page 22) for range. |
| V _{DDQ} | Supply | DQ power supply: 1.2V nominal. Isolated on the device for improved noise immunity. See Table 7 (page 22) for range. |
| V _{EXT} | Supply | Power supply: 2.5V nominal. See Table 7 (page 22) for range. |
| V _{REF} | Supply | Input reference voltage: V _{DDQ} /2 nominal. Provides a reference voltage for the input buffers. |
| V _{SS} | Supply | Ground. |
| V _{SSQ} | Supply | DQ ground: Isolated on the device for improved noise immunity. |
| NC | – | No connect: These balls are not connected to the DRAM. |
| NF | – | No function: These balls are connected to the DRAM, but provide no functionality. |



Package Dimensions

Figure 5: 168-Ball FBGA

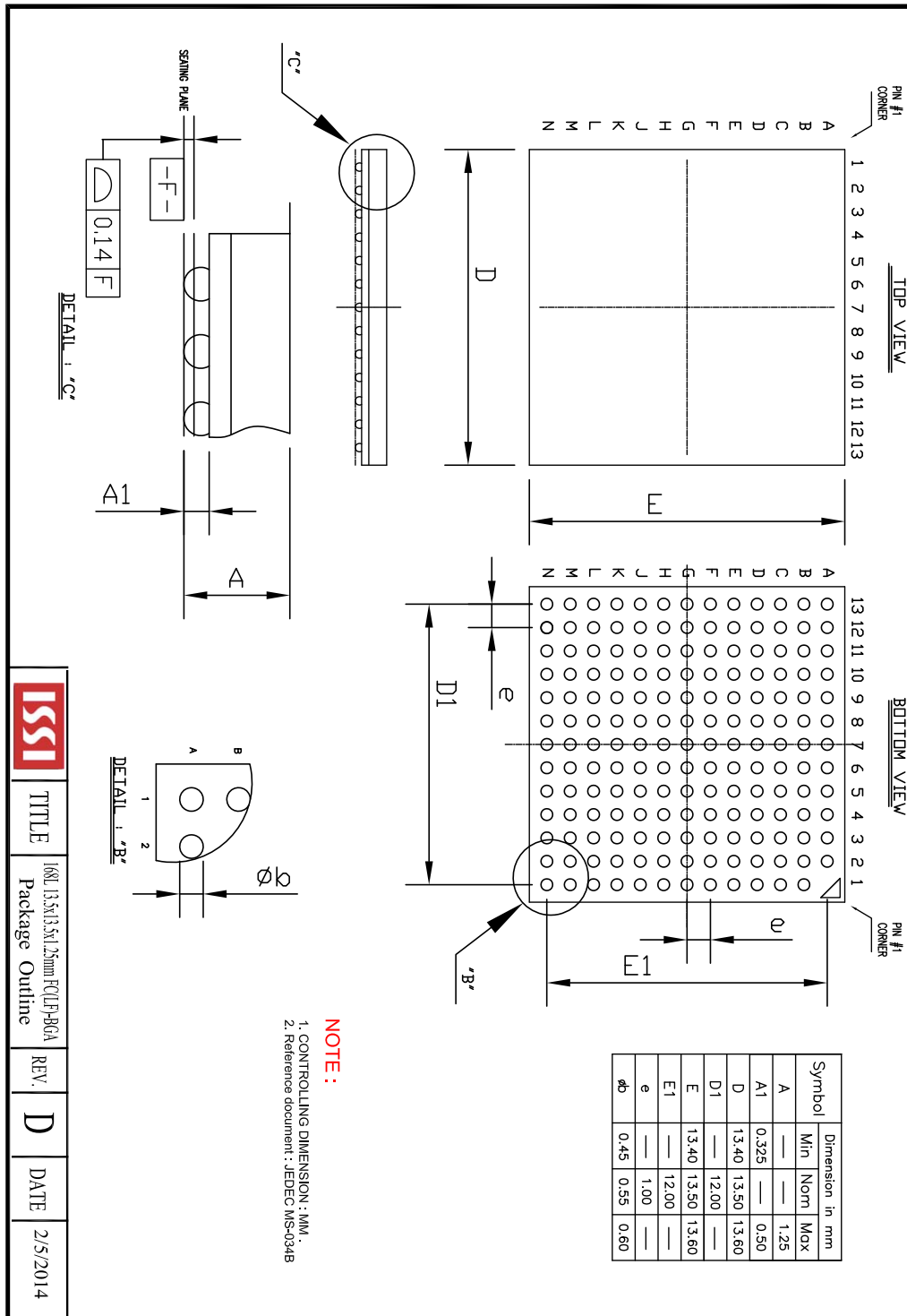



Electrical Characteristics – I_{DD} Specifications

Table 4: I_{DD} Operating Conditions and Maximum Limits

Notes 1–6 apply to the entire table

| Description | Condition | Symbol | -093E | -093 | -107E | -107 | -125F | -125E | -125 | Units | Notes |
|------------------------------|--|--|-------|------|-------|------|-------|-------|------|-------|-------|
| Standby current | t ^{CK} = idle; All banks idle; No inputs toggling | I _{SB1} (V _{DD}) x18 | 125 | 125 | 125 | 125 | 125 | 125 | 125 | mA | 7 |
| | | I _{SB1} (V _{DD}) x36 | 125 | 125 | 125 | 125 | 125 | 125 | 125 | | |
| | | I _{SB1} (V _{EXT}) | 30 | 30 | 30 | 30 | 30 | 30 | 30 | | |
| Clock active standby current | CS# = 1; No commands; Bank address incremented and half address/data change once every four clock cycles | I _{SB2} (V _{DD}) x18 | 870 | 870 | 815 | 815 | 725 | 725 | 725 | mA | |
| | | I _{SB2} (V _{DD}) x36 | 895 | 895 | 835 | 835 | 740 | 740 | 740 | | |
| | | I _{SB2} (V _{EXT}) | 30 | 30 | 30 | 30 | 30 | 30 | 30 | | |
| Operational current: BL2 | BL = 2; Sequential bank access; Bank transitions once every t ^{RC} ; Half address transitions once every t ^{RC} ; Read followed by write sequence; Continuous data during WRITE commands | I _{DD1} (V _{DD}) x18 | 1175 | 1115 | 1100 | 1045 | 990 | 940 | 915 | mA | |
| | | I _{DD1} (V _{DD}) x36 | 1185 | 1125 | 1110 | 1055 | 1000 | 950 | 925 | | |
| | | I _{DD1} (V _{EXT}) | 35 | 35 | 35 | 35 | 35 | 35 | 35 | | |
| Operational current: BL4 | BL = 4; Sequential bank access; Bank transitions once every t ^{RC} ; Half address transitions once every t ^{RC} ; Read followed by write sequence; Continuous data during WRITE commands | I _{DD2} (V _{DD}) x18 | 1205 | 1145 | 1130 | 1075 | 1020 | 970 | 945 | mA | |
| | | I _{DD2} (V _{DD}) x36 | 1215 | 1155 | 1140 | 1080 | 1030 | 980 | 950 | | |
| | | I _{DD2} (V _{EXT}) | 35 | 35 | 35 | 35 | 35 | 35 | 35 | | |
| Operational current: BL8 | BL = 8; Sequential bank access; Bank transitions once every t ^{RC} ; Half address transitions once every t ^{RC} ; Read followed by write sequence; Continuous data during WRITE commands | I _{DD3} (V _{DD}) x18 | 1300 | 1220 | 1200 | 1130 | 1085 | 1030 | 1000 | mA | |
| | | I _{DD3} (V _{DD}) x36 | NA | NA | NA | NA | N/A | NA | NA | | |
| | | I _{DD3} (V _{EXT}) | 35 | 35 | 35 | 35 | 35 | 35 | 35 | | |
| Burst refresh current | Sixteen bank cyclic refresh using Bank Address Control AREF protocol; Command bus remains in refresh for all sixteen banks; DQs are High-Z and at V _{DDQ/2} ; Addresses are at V _{DDQ/2} | I _{REF1} (V _{DD}) x18 | 1550 | 1550 | 1400 | 1400 | 1230 | 1230 | 1230 | mA | |
| | | I _{REF1} (V _{DD}) x36 | 1570 | 1570 | 1420 | 1420 | 1245 | 1245 | 1245 | | |
| | | I _{REF1} (V _{EXT}) | 80 | 80 | 75 | 75 | 70 | 70 | 70 | | |



Table 4: I_{DD} Operating Conditions and Maximum Limits (Continued)

Notes 1–6 apply to the entire table

| Description | Condition | Symbol | -093E | -093 | -107E | -107 | -125F | -125E | -125 | Units | Notes |
|---|---|---|-------|------|-------|------|-------|-------|------|-------|-------|
| Distributed refresh current | Single bank refresh using Bank Address Control AREF protocol; Sequential bank access every 0.489µs; DQs are High-Z and at V _{DDQ/2} ; Addresses are at V _{DDQ/2} | I _{REF2} (V _{DD}) x18 | 875 | 875 | 820 | 820 | 730 | 730 | 730 | mA | |
| | | I _{REF2} (V _{DD}) x36 | 900 | 900 | 840 | 840 | 745 | 745 | 745 | | |
| | | I _{REF2} (V _{EXT}) | 30 | 30 | 30 | 30 | 30 | 30 | 30 | | |
| Multibank refresh current: 4 bank refresh | Quad bank refresh using Multibank AREF protocol; BL = 4; Cyclic bank access; Subject to tSAW and tMMD specifications; DQs are High-Z and at V _{DDQ/2} ; Bank addresses are at V _{DDQ/2} | I _{MREF4} (V _{DD}) x18 | 2130 | 1925 | 2030 | 1810 | 1885 | 1885 | 1645 | mA | |
| | | I _{MREF4} (V _{DD}) x36 | 2155 | 1950 | 2050 | 1830 | 1900 | 1900 | 1660 | | |
| | | I _{MREF4} (V _{EXT}) | 130 | 130 | 115 | 115 | 105 | 105 | 105 | | |
| Operating burst write current : BL2 | BL = 2; Cyclic bank access; Half of address bits change every clock cycle; Continuous data; Measurement is taken during continuous WRITE | I _{DD2W} (V _{DD}) x18 | 2110 | 2110 | 1910 | 1910 | 1665 | 1665 | 1665 | mA | |
| | | I _{DD2W} (V _{DD}) x36 | 2290 | 2290 | 2070 | 2070 | 1805 | 1805 | 1805 | | |
| | | I _{DD2W} (V _{EXT}) | 80 | 80 | 75 | 75 | 70 | 70 | 70 | | |
| Operating burst write current : BL4 | BL = 4; Cyclic bank access; Half of address bits change every two clock cycles; Continuous data; Measurement is taken during continuous WRITE | I _{DD4W} (V _{DD}) x18 | 1730 | 1730 | 1590 | 1590 | 1395 | 1395 | 1395 | mA | |
| | | I _{DD4W} (V _{DD}) x36 | 1815 | 1815 | 1665 | 1665 | 1460 | 1460 | 1460 | | |
| | | I _{DD4W} (V _{EXT}) | 55 | 55 | 55 | 55 | 50 | 50 | 50 | | |
| Operating burst write current : BL8 | BL = 8; Cyclic bank access; Half of address bits change every four clock cycles; Continuous data; Measurement is taken during continuous WRITE | I _{DD8W} (V _{DD}) x18 | 1475 | 1475 | 1335 | 1335 | 1190 | 1190 | 1190 | mA | |
| | | I _{DD8W} (V _{DD}) x36 | NA | NA | NA | NA | NA | NA | NA | | |
| | | I _{DD8W} (V _{EXT}) | 45 | 45 | 40 | 40 | 40 | 40 | 40 | | |
| Multibank write current: Dual bank write | BL = 4; Cyclic bank access using Dual Bank WRITE; Half of address bits change every two clock cycles; Continuous data; Measurement is taken during continuous WRITE | I _{DBWR} (V _{DD}) x18 | 2305 | 2305 | 2170 | 2170 | 1885 | 1885 | 1885 | mA | |
| | | I _{DBWR} (V _{DD}) x36 | 2400 | 2400 | 2250 | 2250 | 1960 | 1960 | 1960 | | |
| | | I _{DBWR} (V _{EXT}) | 80 | 80 | 75 | 75 | 70 | 70 | 70 | | |
| Multibank write current: Quad bank write | BL = 4; Cyclic bank access using Quad Bank WRITE; Half of address bits change every two clock cycles; Continuous data; Measurement is taken during continuous WRITE; Subject to tSAW specification | I _{QBWR} (V _{DD}) x18 | 2965 | 2965 | 2890 | 2890 | 2525 | 2525 | 2525 | mA | |
| | | I _{QBWR} (V _{DD}) x36 | 3195 | 3195 | 3000 | 3000 | 2615 | 2615 | 2615 | | |
| | | I _{QBWR} (V _{EXT}) | 130 | 130 | 115 | 115 | 100 | 100 | 100 | | |



Table 4: I_{DD} Operating Conditions and Maximum Limits (Continued)

Notes 1–6 apply to the entire table

| Description | Condition | Symbol | -093E | -093 | -107E | -107 | -125F | -125E | -125 | Units | Notes |
|--------------------------------------|---|--|-------|------|-------|------|-------|-------|------|-------|-------|
| Operating burst read current example | BL = 2; Cyclic bank access; Half of address bits change every clock cycle; Continuous data; Measurement is taken during continuous READ | I _{DD2R} (V _{DD}) x18 | 2250 | 2250 | 2045 | 2045 | 1785 | 1785 | 1785 | mA | |
| | | I _{DD2R} (V _{DD}) x36 | 2395 | 2395 | 2180 | 2180 | 1895 | 1895 | 1895 | | |
| | | I _{DD2R} (V _{EXT}) | 80 | 80 | 75 | 75 | 70 | 70 | 70 | | |
| Operating burst read current example | BL = 4; Cyclic bank access; Half of address bits change every two clock cycles; Continuous data; Measurement is taken during continuous READ | I _{DD4R} (V _{DD}) x18 | 1740 | 1740 | 1595 | 1595 | 1400 | 1400 | 1400 | mA | |
| | | I _{DD4R} (V _{DD}) x36 | 1835 | 1835 | 1685 | 1685 | 1475 | 1475 | 1475 | | |
| | | I _{DD4R} (V _{EXT}) | 55 | 55 | 55 | 55 | 50 | 50 | 50 | | |
| Operating burst read current example | BL = 8; Cyclic bank access; Half of address bits change every four clock cycles; Continuous data; Measurement is taken during continuous READ | I _{DD8R} (V _{DD}) x18 | 1450 | 1450 | 1315 | 1315 | 1175 | 1175 | 1175 | mA | |
| | | I _{DD8R} (V _{DD}) x36 | NA | NA | NA | NA | NA | NA | NA | | |
| | | I _{DD8R} (V _{EXT}) | 45 | 45 | 40 | 40 | 40 | 40 | 40 | | |



576Mb: x18, x36 RLDRAM 3 Electrical Characteristics – I_{DD} Specifications

- Notes:
1. I_{DD} specifications are tested after the device is properly initialized. $0^{\circ}\text{C} \leq T_C \leq +95^{\circ}\text{C}$;
 $+1.28\text{V} \leq V_{DD} \leq +1.42\text{V}$, $+1.14\text{V} \leq V_{DDQ} \leq +1.26\text{V}$, $+2.38\text{V} \leq V_{EXT} \leq +2.63\text{V}$, $V_{REF} = V_{DDQ}/2$.
 2. I_{DD} measurements use t_{CK} (MIN), t_{RC} (MIN), and minimum data latency (RL and WL).
 3. Input slew rate is 1V/ns for single ended signals and 2V/ns for differential signals.
 4. Definitions for I_{DD} conditions:
 - LOW is defined as $V_{IN} \leq V_{IL(AC)MAX}$.
 - HIGH is defined as $V_{IN} \geq V_{IH(AC)MIN}$.
 - Continuous data is defined as half the DQ signals changing between HIGH and LOW every half clock cycle (twice per clock).
 - Continuous address is defined as half the address signals changing between HIGH and LOW every clock cycle (once per clock).
 - Sequential bank access is defined as the bank address incrementing by one every t_{RC} .
 - Cyclic bank access is defined as the bank address incrementing by one for each command access. For BL = 2 this is every clock, for BL = 4 this is every other clock, and for BL = 8 this is every fourth clock.
 5. CS# is HIGH unless a READ, WRITE, AREF, or MRS command is registered. CS# never transitions more than once per clock cycle.
 6. I_{DD} parameters are specified with ODT disabled.
 7. Upon exiting standby current conditions, at least one NOP command must be issued with stable clock prior to issuing any other valid command.



Electrical Specifications – Absolute Ratings and I/O Capacitance

Absolute Maximum Ratings

Stresses greater than those listed may cause permanent damage to the device. This is a stress rating only, and functional operation of the device at these or any other conditions outside those indicated in the operational sections of this specification is not implied. Exposure to absolute maximum rating conditions for extended periods may adversely affect reliability.

Table 5: Absolute Maximum Ratings

| Symbol | Parameter | Min | Max | Units |
|------------------------------------|--|------|-------|-------|
| V _{DD} | V _{DD} supply voltage relative to V _{SS} | -0.4 | 1.975 | V |
| V _{DDQ} | Voltage on V _{DDQ} supply relative to V _{SS} | -0.4 | 1.66 | V |
| V _{IN} , V _{OUT} | Voltage on any ball relative to V _{SS} | -0.4 | 1.66 | V |
| V _{EXT} | Voltage on V _{EXT} supply relative to V _{SS} | -0.4 | 2.8 | V |

Input/Output Capacitance

Table 6: Input/Output Capacitance

Notes 1 and 2 apply to entire table

| Capacitance Parameters | Symbol | RL3-2133 | | RL3-1866 | | RL3-1600 | | Units | Notes |
|-----------------------------|--------------------------|----------|------|----------|------|----------|------|-------|-------|
| | | Min | Max | Min | Max | Min | Max | | |
| CK/CK# | C _{CK} | 1.3 | 2.1 | 1.3 | 2.1 | 1.3 | 2.2 | pF | |
| ΔC: CK to CK# | C _{DCK} | 0 | 0.15 | 0 | 0.15 | 0 | 0.15 | pF | |
| Single-ended I/O: DQ, DM | C _{IO} | 1.9 | 2.9 | 1.9 | 3.0 | 2.0 | 3.1 | pF | 3 |
| Input strobe: DK/DK# | C _{IO} | 1.9 | 2.9 | 1.9 | 3.0 | 2.0 | 3.1 | pF | |
| Output strobe: QK/QK#, QVLD | C _{IO} | 1.9 | 2.9 | 1.9 | 3.0 | 2.0 | 3.1 | pF | |
| ΔC: DK to DK# | C _{DDK} | 0 | 0.15 | 0 | 0.15 | 0 | 0.15 | pF | |
| ΔC: QK to QK# | C _{DQK} | 0 | 0.15 | 0 | 0.15 | 0 | 0.15 | pF | |
| ΔC: DQ to QK or DQ to DK | C _{DIO} | -0.5 | 0.3 | -0.5 | 0.3 | -0.5 | 0.3 | pF | 4 |
| Inputs (CMD, ADDR) | C _I | 1.25 | 2.25 | 1.25 | 2.25 | 1.25 | 2.25 | pF | 5 |
| ΔC: CMD_ADDR to CK | C _{DI_CMD_ADDR} | -0.5 | 0.3 | -0.5 | 0.3 | -0.4 | 0.4 | pF | 6 |
| JTAG balls | C _{JTAG} | 1.5 | 4.5 | 1.5 | 4.5 | 1.5 | 4.5 | pF | 7 |
| RESET#, MF balls | C _I | - | 3.0 | - | 3.0 | - | 3.0 | pF | |

- Notes:
1. $+1.28V \leq V_{DD} \leq +1.42V$, $+1.14V \leq V_{DDQ} \leq 1.26V$, $+2.38V \leq V_{EXT} \leq +2.63V$, $V_{REF} = V_{SS}$, $f = 100$ MHz, $T_C = 25^\circ C$, $V_{OUT(DC)} = 0.5 \times V_{DDQ}$, V_{OUT} (peak-to-peak) = 0.1V.
 2. Capacitance is not tested on ZQ ball.
 3. DM input is grouped with the I/O balls, because they are matched in loading.
 4. $C_{DIO} = C_{IO(DQ)} - 0.5 \times (C_{IO} [QK] + C_{IO} [QK\#])$.
 5. Includes CS#, REF#, WE#, A[19:0], and BA[3:0].
 6. $C_{DI_CMD_ADDR} = C_I$ (CMD_ADDR) - $0.5 \times (C_{CK} [CK] + C_{CK} [CK\#])$.
 7. JTAG balls are tested at 50 MHz.



AC and DC Operating Conditions

Table 7: DC Electrical Characteristics and Operating Conditions

Note 1 applies to the entire table; Unless otherwise noted: $0^{\circ}\text{C} \leq T_C \leq +95^{\circ}\text{C}$; $+1.28\text{V} \leq V_{DD} \leq +1.42\text{V}$

| Description | Symbol | Min | Max | Units | Notes |
|--|--------------|-----------------------|-----------------------|---------------|-------|
| Supply voltage | V_{EXT} | 2.38 | 2.63 | V | |
| Supply voltage | V_{DD} | 1.28 | 1.42 | V | |
| Isolated output buffer supply | V_{DDQ} | 1.14 | 1.26 | V | |
| Reference voltage | V_{REF} | $0.49 \times V_{DDQ}$ | $0.51 \times V_{DDQ}$ | V | 2, 3 |
| Input HIGH (logic 1) voltage | $V_{IH(DC)}$ | $V_{REF} + 0.10$ | V_{DDQ} | V | |
| Input LOW (logic 0) voltage | $V_{IL(DC)}$ | V_{SS} | $V_{REF} - 0.10$ | V | |
| Input leakage current: Any input $0\text{V} \leq V_{IN} \leq V_{DD}$, V_{REF} ball $0\text{V} \leq V_{IN} \leq 1.1\text{V}$ (All other balls not under test = 0V) | I_{LI} | -2 | 2 | μA | |
| Reference voltage current (All other balls not under test = 0V) | I_{REF} | -5 | 5 | μA | |

- Notes:
1. All voltages referenced to V_{SS} (GND).
 2. The nominal value of V_{REF} is expected to be $0.5 \times V_{DDQ}$ of the transmitting device. V_{REF} is expected to track variations in V_{DDQ} .
 3. Peak-to-peak noise (non-common mode) on V_{REF} may not exceed $\pm 2\%$ of the DC value. DC values are determined to be less than 20 MHz. Peak-to-peak AC noise on V_{REF} should not exceed $\pm 2\%$ of $V_{REF(DC)}$. Thus, from $V_{DDQ}/2$, V_{REF} is allowed $\pm 2\% V_{DDQ}/2$ for DC error and an additional $\pm 2\% V_{DDQ}/2$ for AC noise. The measurement is to be taken at the nearest V_{REF} bypass capacitor.

Table 8: Input AC Logic Levels

Notes 1-3 apply to entire table; Unless otherwise noted: $0^{\circ}\text{C} \leq T_C \leq +95^{\circ}\text{C}$; $+1.28\text{V} \leq V_{DD} \leq +1.42\text{V}$

| Description | Symbol | Min | Max | Units |
|------------------------------|--------------|------------------|------------------|-------|
| Input HIGH (logic 1) voltage | $V_{IH(AC)}$ | $V_{REF} + 0.15$ | - | V |
| Input LOW (logic 0) voltage | $V_{IL(AC)}$ | - | $V_{REF} - 0.15$ | V |

- Notes:
1. All voltages referenced to V_{SS} (GND).
 2. The receiver will effectively switch as a result of the signal crossing the AC input level, and will remain in that state as long as the signal does not ring back above/below the DC input LOW/HIGH level.
 3. Single-ended input slew rate = 1 V/ns; maximum input voltage swing under test is 900mV (peak-to-peak).

Figure 6: Single-Ended Input Signal

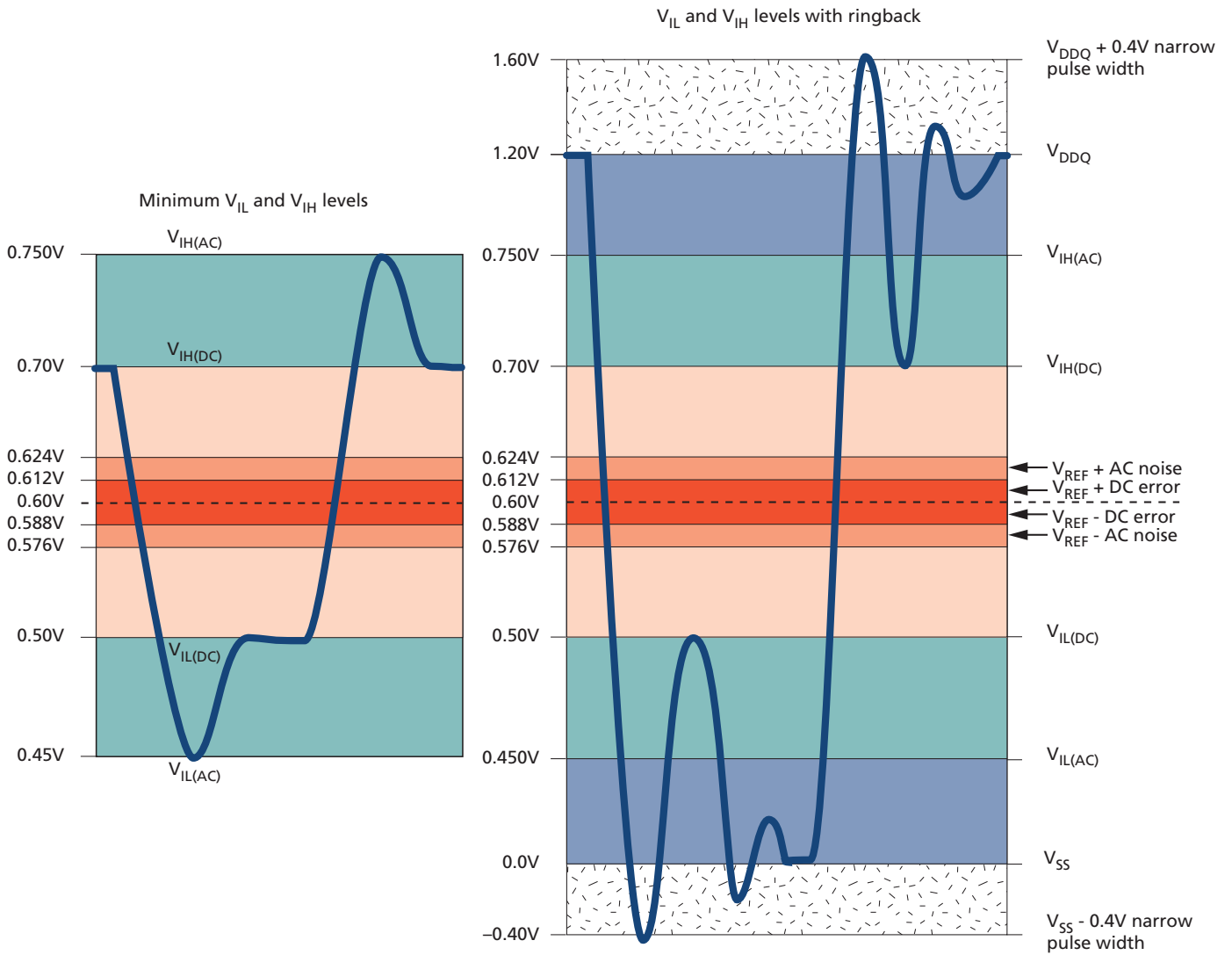



AC Overshoot/Undershoot Specifications

Table 9: Control and Address Balls

| Parameter | RL3-2133 | RL3-1866 | RL3-1600 |
|--|----------|----------|----------|
| Maximum peak amplitude allowed for overshoot area | 0.4V | 0.4V | 0.4V |
| Maximum peak amplitude allowed for undershoot area | 0.4V | 0.4V | 0.4V |
| Maximum overshoot area above V_{DDQ} | 0.25 Vns | 0.28 Vns | 0.33 Vns |
| Maximum undershoot area below V_{SS}/V_{SSQ} | 0.25 Vns | 0.28 Vns | 0.33 Vns |

Table 10: Clock, Data, Strobe, and Mask Balls

| Parameter | RL3-2133 | RL3-1866 | RL3-1600 |
|--|----------|----------|----------|
| Maximum peak amplitude allowed for overshoot area | 0.4V | 0.4V | 0.4V |
| Maximum peak amplitude allowed for undershoot area | 0.4V | 0.4V | 0.4V |
| Maximum overshoot area above V_{DDQ} | 0.10 Vns | 0.11 Vns | 0.13 Vns |
| Maximum undershoot area below V_{SS}/V_{SSQ} | 0.10 Vns | 0.11 Vns | 0.13 Vns |

Figure 7: Overshoot

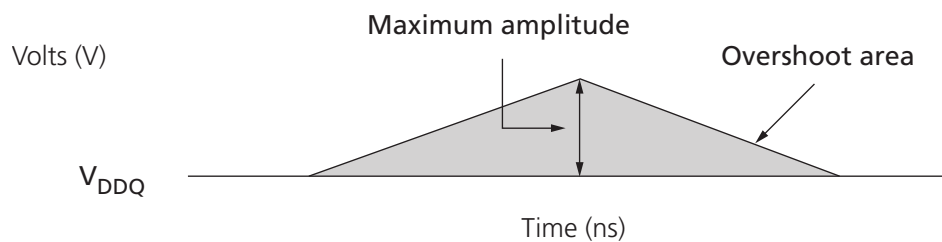

Figure 8: Undershoot

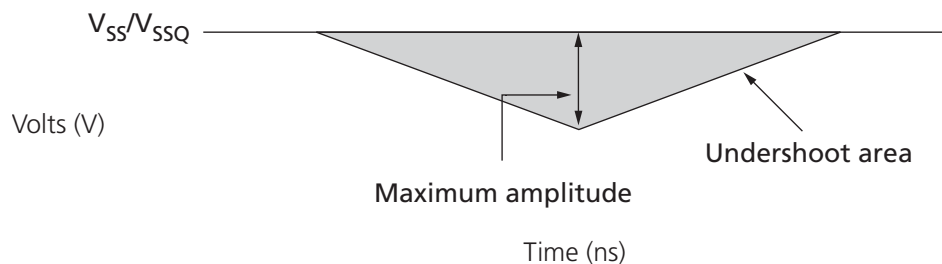

Table 11: Differential Input Operating Conditions (CK, CK# and DKx, DKx#)

Notes 1 and 2 apply to entire table

| Parameter/Condition | Symbol | Min | Max | Units | Notes |
|--|---------------------|-----------------------------------|-----------------------------------|-------|-------|
| Differential input voltage logic HIGH – slew | $V_{IH,diff_slew}$ | +200 | n/a | mV | 3 |
| Differential input voltage logic LOW – slew | $V_{IL,diff_slew}$ | n/a | -200 | mV | 3 |
| Differential input voltage logic HIGH | $V_{IH,diff(AC)}$ | $2 \times (V_{IH(AC)} - V_{REF})$ | V_{DDQ} | mV | 4 |
| Differential input voltage logic LOW | $V_{IL,diff(AC)}$ | V_{SSQ} | $2 \times (V_{IL(AC)} - V_{REF})$ | mV | 5 |
| Differential input crossing voltage relative to $V_{DD}/2$ | V_{IX} | $V_{REF(DC)} - 150$ | $V_{REF(DC)} + 150$ | mV | 6 |
| Single-ended HIGH level | V_{SEH} | $V_{IH(AC)}$ | V_{DDQ} | mV | 4 |
| Single-ended LOW level | V_{SEL} | V_{SSQ} | $V_{IL(AC)}$ | mV | 5 |

- Notes:
1. CK/CK# and DKx/DKx# are referenced to V_{DDQ} and V_{SSQ} .
 2. Differential input slew rate = 2 V/ns.
 3. Defines slew rate reference points, relative to input crossing voltages.
 4. Maximum limit is relative to single-ended signals; overshoot specifications are applicable.
 5. Minimum limit is relative to single-ended signals; undershoot specifications are applicable.
 6. The typical value of V_{IX} is expected to be about $0.5 \times V_{DDQ}$ of the transmitting device and V_{IX} is expected to track variations in V_{DDQ} . V_{IX} indicates the voltage at which differential input signals must cross.

Figure 9: V_{IX} for Differential Signals

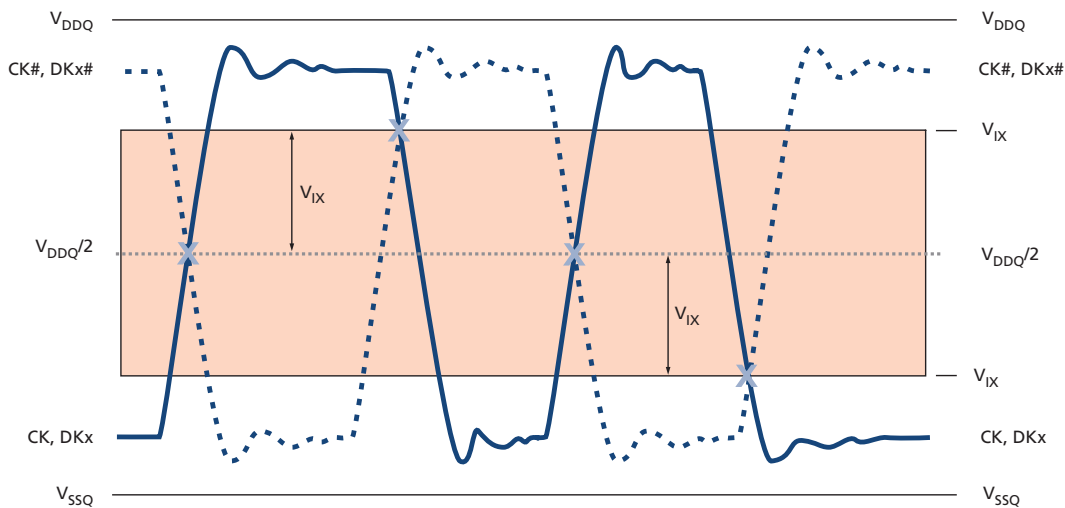

Figure 10: Single-Ended Requirements for Differential Signals

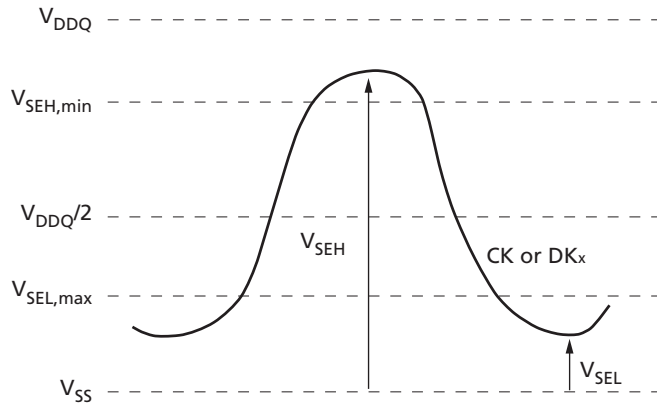

Figure 11: Definition of Differential AC Swing and t_{DVAC}

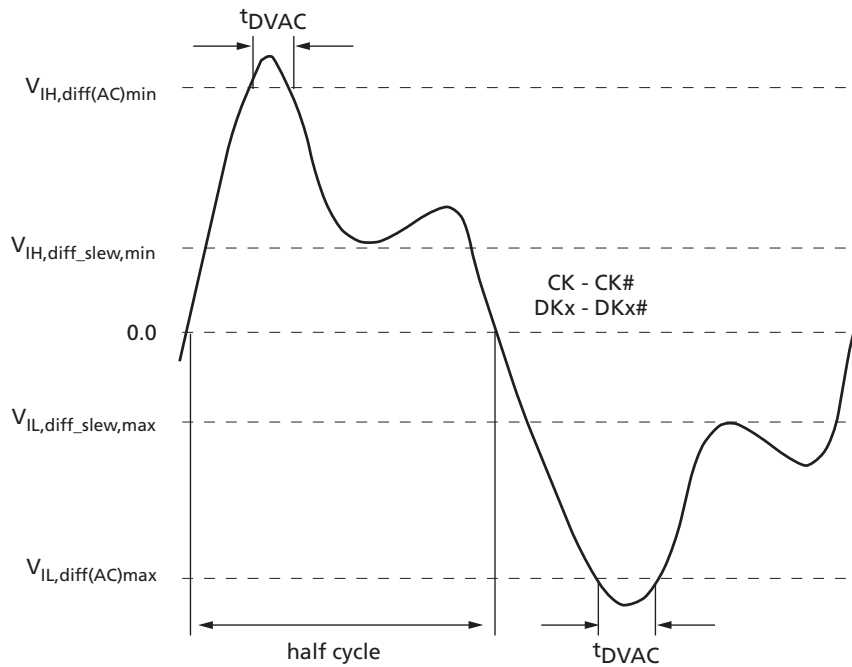



Table 12: Allowed Time Before Ringback (^tDVAC) for CK, CK#, DKx, and DKx#

| Slew Rate (V/ns) | MIN ^t DVAC (ps) at V _{IH} /V _{IL,diff(AC)} |
|------------------|--|
| >4.0 | 175 |
| 4.0 | 170 |
| 3.0 | 167 |
| 2.0 | 163 |
| 1.9 | 162 |
| 1.6 | 161 |
| 1.4 | 159 |
| 1.2 | 155 |
| 1.0 | 150 |
| <1.0 | 150 |

Slew Rate Definitions for Single-Ended Input Signals

Setup (^tIS and ^tDS) nominal slew rate for a rising signal is defined as the slew rate between the last crossing of V_{REF} and the first crossing of V_{IH(AC)min}. Setup (^tIS and ^tDS) nominal slew rate for a falling signal is defined as the slew rate between the last crossing of V_{REF} and the first crossing of V_{IL(AC)max}.

Hold (^tIH and ^tDH) nominal slew rate for a rising signal is defined as the slew rate between the last crossing of V_{IL(DC)max} and the first crossing of V_{REF}. Hold (^tIH and ^tDH) nominal slew rate for a falling signal is defined as the slew rate between the last crossing of V_{IH(DC)min} and the first crossing of V_{REF} (see Figure 12 (page 28)).

Table 13: Single-Ended Input Slew Rate Definition

| Input Slew Rates (Linear Signals) | | Measured | | Calculation |
|--------------------------------------|---------|------------------------|------------------------|--|
| Input | Edge | From | To | |
| Setup | Rising | V _{REF} | V _{IH(AC)min} | $[V_{IH(AC)min} - V_{REF}]/\Delta TRS$ |
| | Falling | V _{REF} | V _{IL(AC)max} | $[V_{REF} - V_{IL(AC)max}]/\Delta TFS$ |
| Hold | Rising | V _{IL(DC)max} | V _{REF} | $[V_{REF} - V_{IL(DC)max}]/\Delta TRH$ |
| | Falling | V _{IH(DC)min} | V _{REF} | $[V_{IH(DC)min} - V_{REF}]/\Delta TFH$ |

Figure 12: Nominal Slew Rate Definition for Single-Ended Input Signals

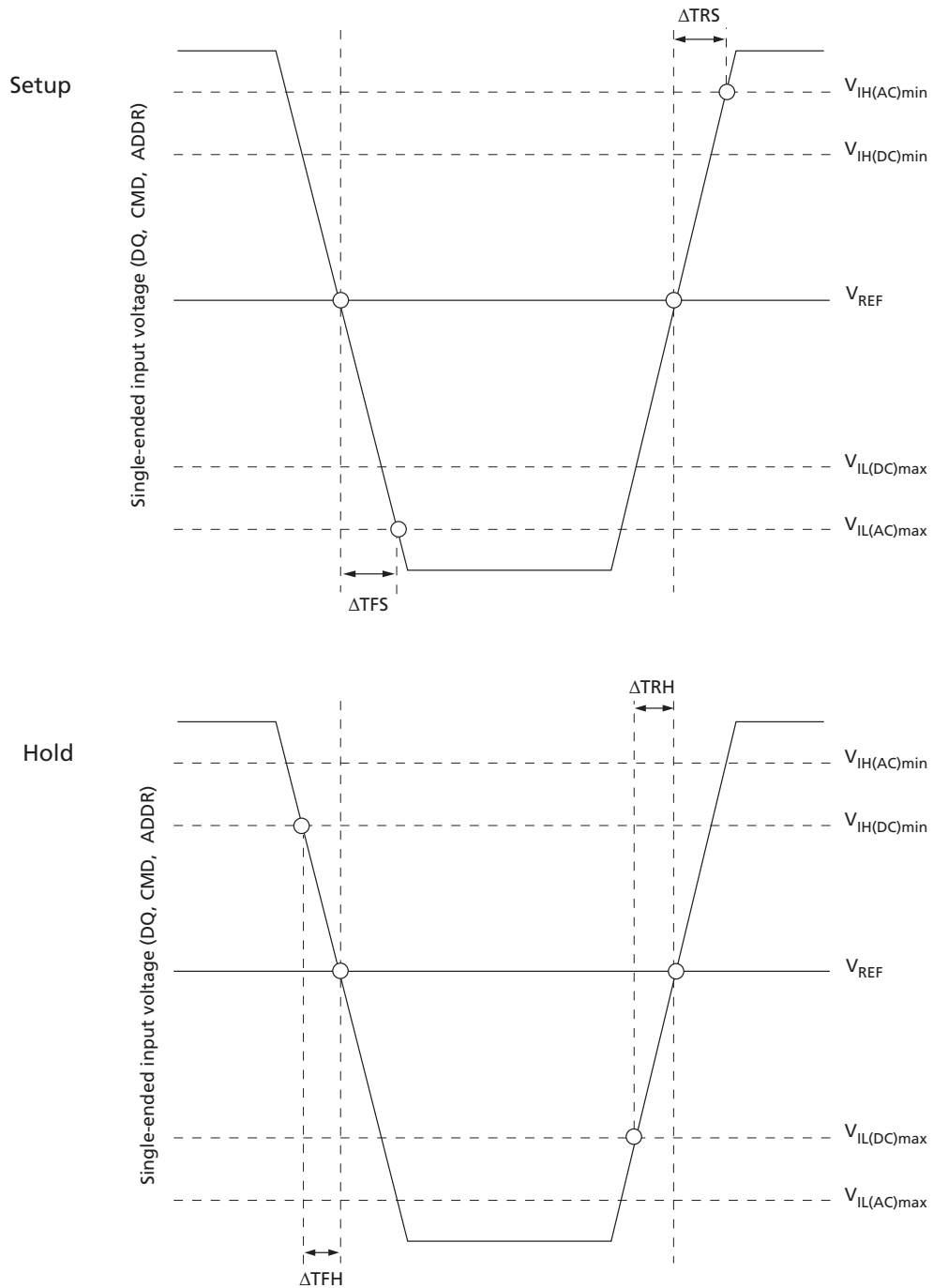



Slew Rate Definitions for Differential Input Signals

Input slew rate for differential signals (CK, CK# and DKx, DKx#) are defined and measured as shown in the following two tables. The nominal slew rate for a rising signal is defined as the slew rate between $V_{IL,diff,max}$ and $V_{IH,diff,min}$. The nominal slew rate for a falling signal is defined as the slew rate between $V_{IH,diff,min}$ and $V_{IL,diff,max}$.

Table 14: Differential Input Slew Rate Definition

| Differential Input Slew Rates (Linear Signals) | | Measured | | Calculation |
|--|---------|-------------------------|-------------------------|--|
| Input | Edge | From | To | |
| CK and DK reference | Rising | $V_{IL,diff_slew,max}$ | $V_{IH,diff_slew,min}$ | $[V_{IH,diff_slew,min} - V_{IL,diff_slew,max}] / \Delta TR_{diff}$ |
| | Falling | $V_{IH,diff_slew,min}$ | $V_{IL,diff_slew,max}$ | $[V_{IH,diff_slew,min} - V_{IL,diff_slew,max}] / \Delta TF_{diff}$ |

Figure 13: Nominal Differential Input Slew Rate Definition for CK, CK#, DKx, and DKx#

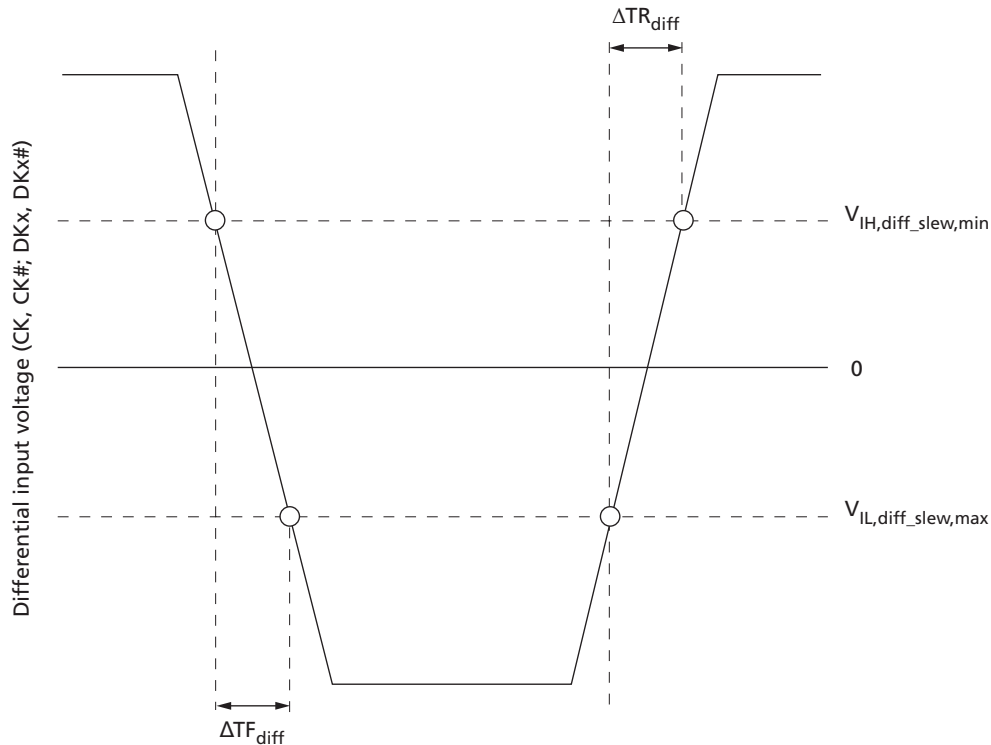

ODT Characteristics

ODT effective resistance, R_{TT} , is defined by MR1[4:2]. ODT is applied to the DQ, DM, and DKx, DKx# balls. The individual pull-up and pull-down resistors (R_{TTPU} and R_{TTPD}) are defined as follows:

$$R_{TTPU} = (V_{DDQ} - V_{OUT}) / |I_{OUT}|, \text{ under the condition that } R_{TTPD} \text{ is turned off}$$

$$R_{TTPD} = (V_{OUT}) / |I_{OUT}|, \text{ under the condition that } R_{TTPU} \text{ is turned off}$$

Figure 14: ODT Levels and I-V Characteristics

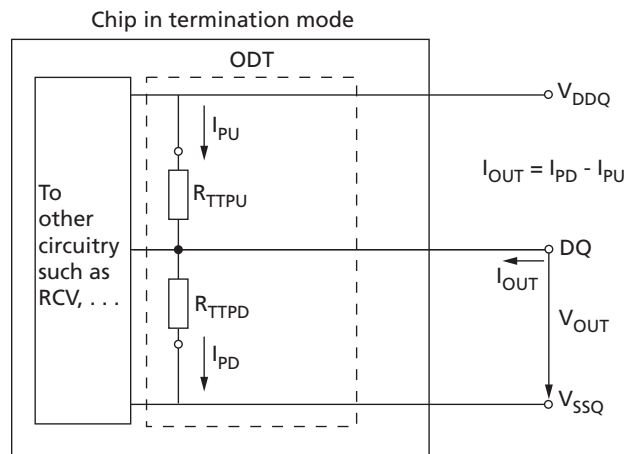

Table 15: ODT DC Electrical Characteristics

| Parameter/Condition | Symbol | Min | Nom | Max | Units | Notes |
|--|---------------|-------------------------|-----|-----|-------|-------|
| R_{TT} effective impedance from $V_{IL(AC)}$ to $V_{IH(AC)}$ | R_{TT_EFF} | See Table 16 (page 31). | | | | 1, 2 |
| Deviation of V_M with respect to $V_{DDQ}/2$ | ΔV_m | -5 | - | +5 | % | 3 |

- Notes:
1. Tolerance limits are applicable after proper ZQ calibration has been performed at a stable temperature and voltage. Refer to ODT Sensitivity (page 32) if either the temperature or voltage changes after calibration.
 2. Measurement definition for R_{TT} : Apply $V_{IH(AC)}$ to ball under test and measure current $I[V_{IH(AC)}]$, then apply $V_{IL(AC)}$ to ball under test and measure current $I[V_{IL(AC)}]$:

$$R_{TT} = \frac{V_{IH(AC)} - V_{IL(AC)}}{|I[V_{IH(AC)}] - I[V_{IL(AC)}]|}$$

3. Measure voltage (V_M) at the tested ball with no load:

$$\Delta VM = \left(\frac{2 \times VM}{V_{DDQ}} - 1 \right) \times 100$$

ODT Resistors

The on-die termination resistance is selected by MR1[4:2]. The following table provides an overview of the ODT DC electrical characteristics. The values provided are not speci-



fication requirements; however, they can be used as design guidelines to indicate what R_{TT} is targeted to provide:

- R_{TT} 120Ω is made up of $R_{TT120(PD240)}$ and $R_{TT120(PU240)}$.
- R_{TT} 60Ω is made up of $R_{TT60(PD120)}$ and $R_{TT60(PU120)}$.
- R_{TT} 40Ω is made up of $R_{TT40(PD80)}$ and $R_{TT40(PU80)}$.

Table 16: R_{TT} Effective Impedances

| R_{TT} | Resistor | V_{out} | Min | Nom | Max | Units |
|----------|--------------------|------------------------------|-----|-----|-----|-------|
| 120Ω | $R_{TT120(PD240)}$ | $0.2 \times V_{DDQ}$ | 0.6 | 1.0 | 1.1 | RZQ/1 |
| | | $0.5 \times V_{DDQ}$ | 0.9 | 1.0 | 1.1 | RZQ/1 |
| | | $0.8 \times V_{DDQ}$ | 0.9 | 1.0 | 1.4 | RZQ/1 |
| | $R_{TT120(PU240)}$ | $0.2 \times V_{DDQ}$ | 0.9 | 1.0 | 1.4 | RZQ/1 |
| | | $0.5 \times V_{DDQ}$ | 0.9 | 1.0 | 1.1 | RZQ/1 |
| | | $0.8 \times V_{DDQ}$ | 0.6 | 1.0 | 1.1 | RZQ/1 |
| 120Ω | | $V_{IL(AC)}$ to $V_{IH(AC)}$ | 0.9 | 1.0 | 1.6 | RZQ/2 |
| 60Ω | $R_{TT60(PD120)}$ | $0.2 \times V_{DDQ}$ | 0.6 | 1.0 | 1.1 | RZQ/2 |
| | | $0.5 \times V_{DDQ}$ | 0.9 | 1.0 | 1.1 | RZQ/2 |
| | | $0.8 \times V_{DDQ}$ | 0.9 | 1.0 | 1.4 | RZQ/2 |
| | $R_{TT60(PU120)}$ | $0.2 \times V_{DDQ}$ | 0.9 | 1.0 | 1.4 | RZQ/2 |
| | | $0.5 \times V_{DDQ}$ | 0.9 | 1.0 | 1.1 | RZQ/2 |
| | | $0.8 \times V_{DDQ}$ | 0.6 | 1.0 | 1.1 | RZQ/2 |
| 60Ω | | $V_{IL(AC)}$ to $V_{IH(AC)}$ | 0.9 | 1.0 | 1.6 | RZQ/4 |
| 40Ω | $R_{TT40(PD80)}$ | $0.2 \times V_{DDQ}$ | 0.6 | 1.0 | 1.1 | RZQ/3 |
| | | $0.5 \times V_{DDQ}$ | 0.9 | 1.0 | 1.1 | RZQ/3 |
| | | $0.8 \times V_{DDQ}$ | 0.9 | 1.0 | 1.4 | RZQ/3 |
| | $R_{TT40(PU80)}$ | $0.2 \times V_{DDQ}$ | 0.9 | 1.0 | 1.4 | RZQ/3 |
| | | $0.5 \times V_{DDQ}$ | 0.9 | 1.0 | 1.1 | RZQ/3 |
| | | $0.8 \times V_{DDQ}$ | 0.6 | 1.0 | 1.1 | RZQ/3 |
| 40Ω | | $V_{IL(AC)}$ to $V_{IH(AC)}$ | 0.9 | 1.0 | 1.6 | RZQ/6 |



ODT Sensitivity

If either temperature or voltage changes after I/O calibration, then the tolerance limits listed in Table 15 (page 30) and Table 16 (page 31) can be expected to widen according to Table 17 (page 32) and Table 18 (page 32).

Table 17: ODT Sensitivity Definition

| Symbol | Min | Max | Units |
|----------|---|---|-------------|
| R_{TT} | $0.9 - dR_{TT}dT \times DT - dR_{TT}dV \times DV $ | $1.6 + dR_{TT}dT \times DT + dR_{TT}dV \times DV $ | RZQ/(2,4,6) |

Note: 1. $DT = T - T(@ \text{calibration})$, $DV = V_{DDQ} - V_{DDQ}(@ \text{calibration})$ or $V_{DD} - V_{DD}(@ \text{calibration})$.

Table 18: ODT Temperature and Voltage Sensitivity

| Change | Min | Max | Units |
|-------------|-----|------|-------|
| $dR_{TT}dT$ | 0 | 1.5 | %/°C |
| $dR_{TT}dV$ | 0 | 0.15 | %/mV |

Output Driver Impedance

The output driver impedance is selected by MR1[1:0] during initialization. The selected value is able to maintain the tight tolerances specified if proper ZQ calibration is performed.

Output specifications refer to the default output driver unless specifically stated otherwise. A functional representation of the output buffer is shown below. The output driver impedance R_{ON} is defined by the value of the external reference resistor RZQ as follows:

- $R_{ON,x} = RZQ/y$ (with $RZQ = 240\Omega \pm 1\%$; $x = 40\Omega$ or 60Ω with $y = 6$ or 4 , respectively)

The individual pull-up and pull-down resistors ($R_{ON(PU)}$ and $R_{ON(PD)}$) are defined as follows:

- $R_{ON(PU)} = (V_{DDQ} - V_{OUT})/|I_{OUT}|$, when $R_{ON(PD)}$ is turned off
- $R_{ON(PD)} = (V_{OUT})/|I_{OUT}|$, when $R_{ON(PU)}$ is turned off

Figure 15: Output Driver

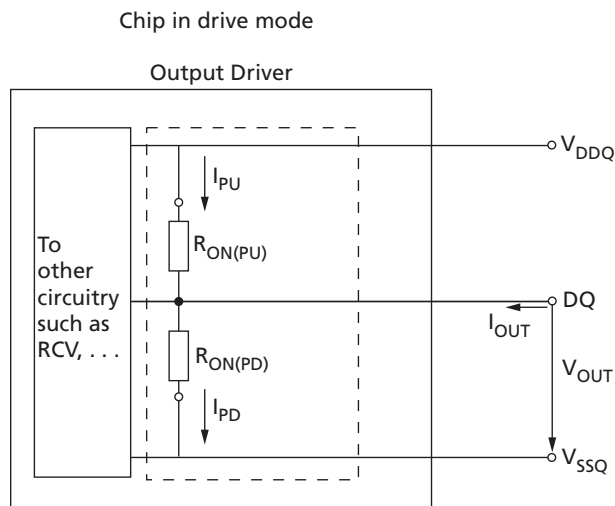



Table 19: Driver Pull-Up and Pull-Down Impedance Calculations

| R_{ON} | | Min | Nom | Max | Units |
|-----------------------|------------------------|------------|------------|------------|--------------|
| RZQ/6 = (240Ω ±1%)/6 | | 39.6 | 40 | 40.4 | Ω |
| RZQ/4 = (240Ω ±1%)/4 | | 59.4 | 60 | 60.6 | Ω |
| Driver | V_{OUT} | Min | Nom | Max | Units |
| 40Ω pull-down | 0.2 × V _{DDQ} | 24 | 40 | 44 | Ω |
| | 0.5 × V _{DDQ} | 36 | 40 | 44 | Ω |
| | 0.8 × V _{DDQ} | 36 | 40 | 56 | Ω |
| 40Ω pull-up | 0.2 × V _{DDQ} | 36 | 40 | 56 | Ω |
| | 0.5 × V _{DDQ} | 36 | 40 | 44 | Ω |
| | 0.8 × V _{DDQ} | 24 | 40 | 44 | Ω |
| 60Ω pull-down | 0.2 × V _{DDQ} | 36 | 60 | 66 | Ω |
| | 0.5 × V _{DDQ} | 54 | 60 | 66 | Ω |
| | 0.8 × V _{DDQ} | 54 | 60 | 84 | Ω |
| 60Ω pull-up | 0.2 × V _{DDQ} | 54 | 60 | 84 | Ω |
| | 0.5 × V _{DDQ} | 54 | 60 | 66 | Ω |
| | 0.8 × V _{DDQ} | 36 | 60 | 66 | Ω |



Output Driver Sensitivity

If either the temperature or the voltage changes after ZQ calibration, then the tolerance limits listed in Table 19 (page 34) can be expected to widen according to Table 20 (page 35) and Table 21 (page 35).

Table 20: Output Driver Sensitivity Definition

| Symbol | Min | Max | Units |
|-----------------------------------|---|---|------------|
| $R_{ON(PD)} @ 0.2 \times V_{DDQ}$ | $0.6 - dR_{ONdTH} \times DT - dR_{ONdVH} \times DV$ | $1.1 + dR_{ONdTH} \times DT + dR_{ONdVH} \times DV$ | RZQ/(6, 4) |
| $R_{ON(PD)} @ 0.5 \times V_{DDQ}$ | $0.9 - dR_{ONdTM} \times DT - dR_{ONdVM} \times DV$ | $1.1 + dR_{ONdTM} \times DT + dR_{ONdVM} \times DV$ | RZQ/(6, 4) |
| $R_{ON(PD)} @ 0.8 \times V_{DDQ}$ | $0.9 - dR_{ONdTL} \times DT - dR_{ONdVL} \times DV$ | $1.4 + dR_{ONdTL} \times DT + dR_{ONdVL} \times D$ | RZQ/(6, 4) |
| $R_{ON(PU)} @ 0.2 \times V_{DDQ}$ | $0.9 - dR_{ONdTH} \times DT - dR_{ONdVH} \times DV$ | $1.4 + dR_{ONdTH} \times DT + dR_{ONdVH} \times DV$ | RZQ/(6, 4) |
| $R_{ON(PU)} @ 0.5 \times V_{DDQ}$ | $0.9 - dR_{ONdTM} \times DT - dR_{ONdVM} \times DV$ | $1.1 + dR_{ONdTM} \times DT + dR_{ONdVM} \times DV$ | RZQ/(6, 4) |
| $R_{ON(PU)} @ 0.8 \times V_{DDQ}$ | $0.6 - dR_{ONdTL} \times DT - dR_{ONdVL} \times DV$ | $1.1 + dR_{ONdTL} \times DT + dR_{ONdVL} \times DV$ | RZQ/(6, 4) |

Note: 1. $DT = T - T(@ \text{ calibration})$, $DV = V_{DDQ} - V_{DDQ}(@ \text{ calibration})$ or $V_{DD} - V_{DD}(@ \text{ calibration})$.

Table 21: Output Driver Voltage and Temperature Sensitivity

| Change | Min | Max | Unit |
|--------------|-----|------|------|
| dR_{ONdTM} | 0 | 1.5 | %/°C |
| dR_{ONdVM} | 0 | 0.15 | %/mV |
| dR_{ONdTL} | 0 | 1.5 | %/°C |
| dR_{ONdVL} | 0 | 0.15 | %/mV |
| dR_{ONdTH} | 0 | 1.5 | %/°C |
| dR_{ONdVH} | 0 | 0.15 | %/mV |



Output Characteristics and Operating Conditions

Table 22: Single-Ended Output Driver Characteristics

Note 1 and 2 apply to entire table

| Parameter/Condition | Symbol | Min | Max | Units | Notes |
|--|---|-------------------------------|-----|---------|---------|
| Output leakage current; DQ are disabled; Any output ball $0V \leq V_{OUT} \leq V_{DDQ}$; ODT is disabled; All other balls not under test = 0V | I_{OZ} | -5 | 5 | μA | |
| Output slew rate: Single-ended; For rising and falling edges, measures between $V_{OL(AC)} = V_{REF} - 0.1 \times V_{DDQ}$ and $V_{OH(AC)} = V_{REF} + 0.1 \times V_{DDQ}$ | SRQ_{SE} | 2.5 | 6 | V/ns | 4, 5 |
| Single-ended DC high-level output voltage | $V_{OH(DC)}$ | $0.8 \times V_{DDQ}$ | | V | 6 |
| Single-ended DC mid-point level output voltage | $V_{OM(DC)}$ | $0.5 \times V_{DDQ}$ | | V | 6 |
| Single-ended DC low-level output voltage | $V_{OL(DC)}$ | $0.2 \times V_{DDQ}$ | | V | 6 |
| Single-ended AC high-level output voltage | $V_{OH(AC)}$ | $V_{TT} + 0.1 \times V_{DDQ}$ | | V | 7, 8, 9 |
| Single-ended AC low-level output voltage | $V_{OL(AC)}$ | $V_{TT} - 0.1 \times V_{DDQ}$ | | V | 7, 8, 9 |
| Impedance delta between pull-up and pull-down for DQ and QVLD | MM_{PUPD} | -10 | 10 | % | 3 |
| Test load for AC timing and output slew rates | Output to V_{TT} ($V_{DDQ}/2$) via 25 Ω resistor | | | | 9 |

- Notes:
- All voltages are referenced to V_{SS} .
 - RZQ is 240 Ω ($\pm 1\%$) and is applicable after proper ZQ calibration has been performed at a stable temperature and voltage.
 - Measurement definition for mismatch between pull-up and pull-down (MM_{PUPD}). Measure both $R_{ON(PU)}$ and $R_{ON(PD)}$ at $0.5 \times V_{DDQ}$:

$$MM_{PUPD} = \frac{R_{onPU} - R_{onPD}}{R_{onNOM}} \times 100$$

- The 6 V/ns maximum is applicable for a single DQ signal when it is switching either from HIGH to LOW or LOW to HIGH while the remaining DQ signals in the same byte lane are either all static or switching the opposite direction. For all other DQ signal switching combinations, the maximum limit of 6 V/ns is reduced to 5 V/ns.
- See Table 24 (page 40) for output slew rate.
- See the Driver Pull-Up and Pull-Down Impedance Calculations table for IV curve linearity. Do not use AC test load.
- $V_{TT} = V_{DDQ}/2$
- See Figure 16 (page 38) for an example of a single-ended output signal.
- See Figure 18 (page 39) for the test load configuration.



Table 23: Differential Output Driver Characteristics

Notes 1 and 2 apply to entire table

| Parameter/Condition | Symbol | Min | Max | Units | Notes |
|--|---|-----------------------|-----------------|---------|-------|
| Output leakage current; DQ are disabled; Any output ball $0V \leq V_{OUT} \leq V_{DDQ}$; ODT is disabled; All other balls not under test = 0V | I_{OZ} | -5 | 5 | μA | |
| Output slew rate: Differential; For rising and falling edges, measures between $V_{OL,diff(AC)} = -0.2 \times V_{DDQ}$ and $V_{OH,diff(AC)} = +0.2 \times V_{DDQ}$ | SRQ_{diff} | 5 | 12 | V/ns | 5 |
| Output differential cross-point voltage | $V_{OX(AC)}$ | $V_{REF} - 150$ | $V_{REF} + 150$ | mV | 6 |
| Differential high-level output voltage | $V_{OH,diff(AC)}$ | $+0.2 \times V_{DDQ}$ | | V | 6 |
| Differential low-level output voltage | $V_{OL,diff(AC)}$ | $-0.2 \times V_{DDQ}$ | | V | 6 |
| Delta resistance between pull-up and pull-down for QK/QK# | MM_{PUPD} | -10 | 10 | % | 3 |
| Test load for AC timing and output slew rates | Output to V_{TT} ($V_{DDQ}/2$) via 25 Ω resistor | | | | 4 |

- Notes:
1. All voltages are referenced to V_{SS} .
 2. RZQ is 240 Ω ($\pm 1\%$) and is applicable after proper ZQ calibration has been performed at a stable temperature and voltage.
 3. Measurement definition for mismatch between pull-up and pull-down (MM_{PUPD}). Measure both $R_{ON(PU)}$ and $R_{ON(PD)}$ at $0.5 \times V_{DDQ}$:

$$MM_{PUPD} = \frac{R_{onPU} - R_{onPD}}{R_{onNOM}} \times 100$$

4. See Figure 18 (page 39) for the test load configuration.
5. See Table 25 (page 41) for the output slew rate.
6. See Figure 17 (page 39) for an example of a differential output signal.

Figure 16: DQ Output Signal

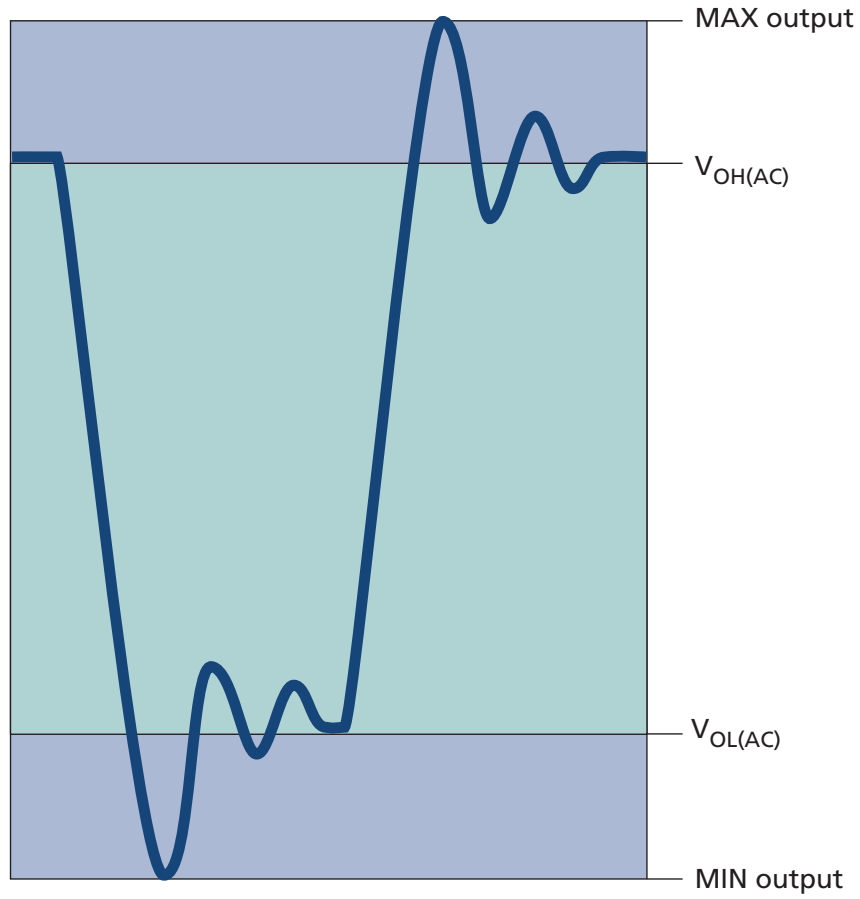
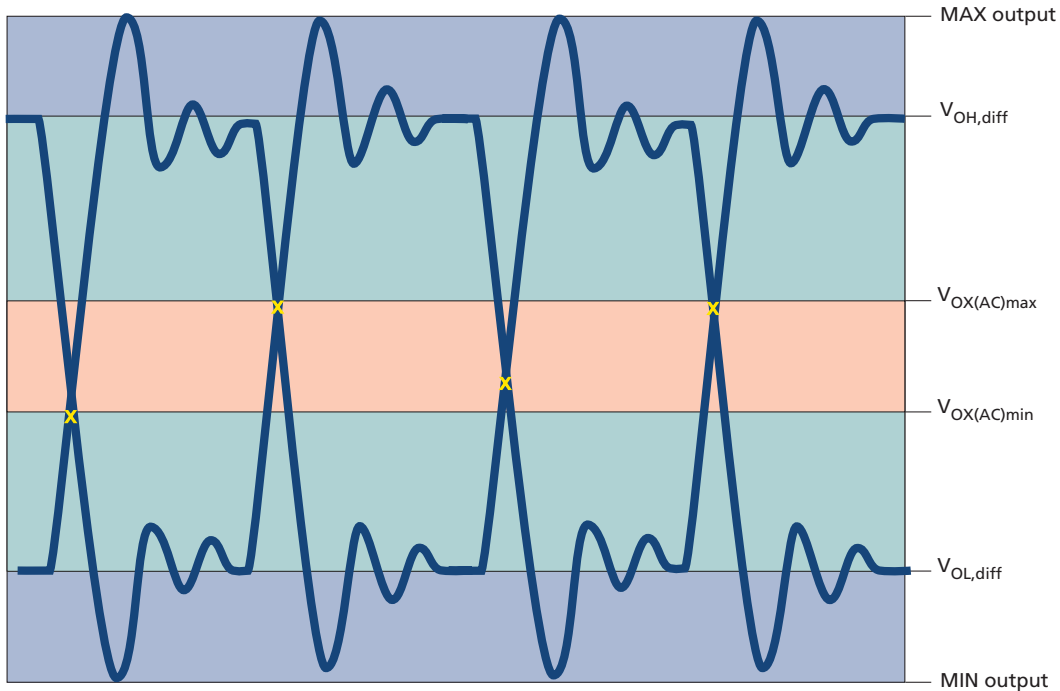

Figure 17: Differential Output Signal



Reference Output Load

The following figure represents the effective reference load of 25Ω used in defining the relevant device AC timing parameters as well as the output slew rate measurements. It is not intended to be a precise representation of a particular system environment or a depiction of the actual load presented by a production tester. System designers should use IBIS or other simulation tools to correlate the timing reference load to a system environment.

Figure 18: Reference Output Load for AC Timing and Output Slew Rate

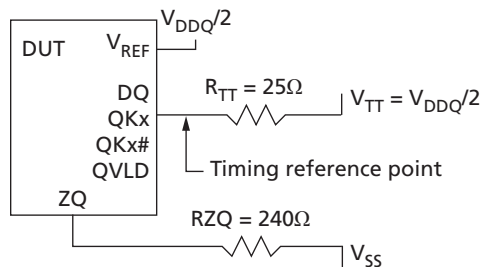



Slew Rate Definitions for Single-Ended Output Signals

The single-ended output driver is summarized in the following table. With the reference load for timing measurements, the output slew rate for falling and rising edges is defined and measured between $V_{OL(AC)}$ and $V_{OH(AC)}$ for single-ended signals.

Table 24: Single-Ended Output Slew Rate Definition

| Single-Ended Output Slew Rates (Linear Signals) | | Measured | | Calculation |
|---|---------|--------------|--------------|--|
| Output | Edge | From | To | |
| DQ and QVLD | Rising | $V_{OL(AC)}$ | $V_{OH(AC)}$ | $\frac{V_{OH(AC)} - V_{OL(AC)}}{\Delta TR_{SE}}$ |
| | Falling | $V_{OH(AC)}$ | $V_{OL(AC)}$ | $\frac{V_{OH(AC)} - V_{OL(AC)}}{\Delta TF_{SE}}$ |

Figure 19: Nominal Slew Rate Definition for Single-Ended Output Signals

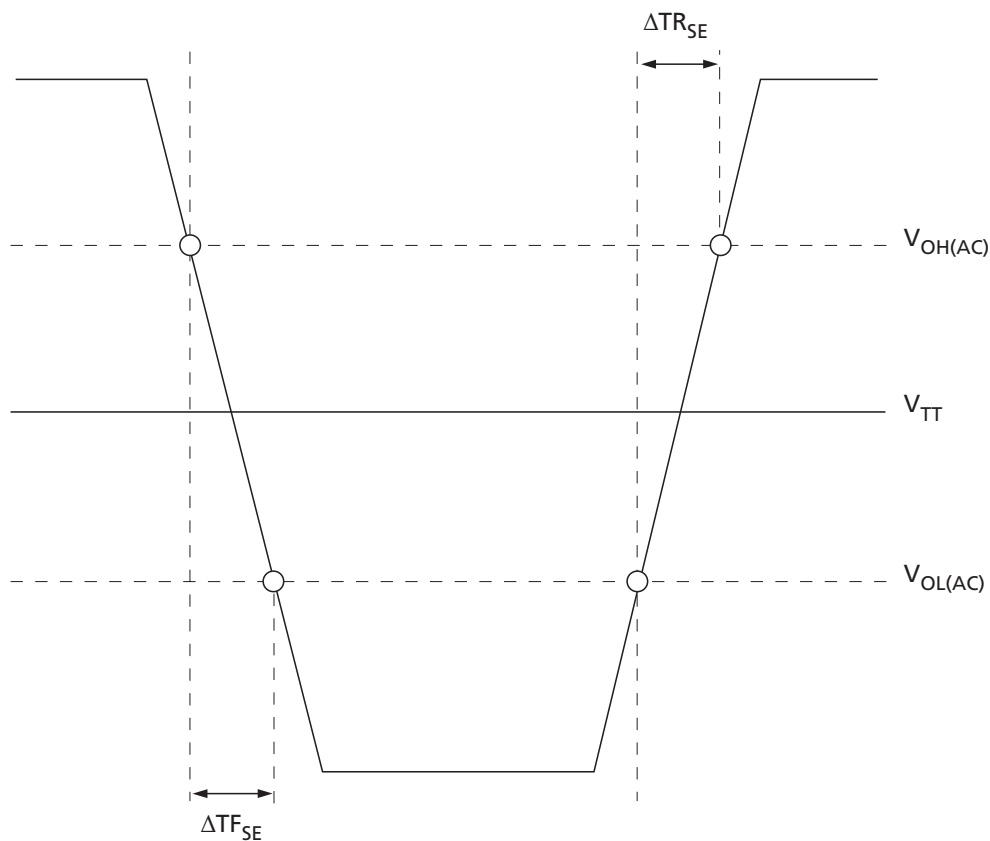



Slew Rate Definitions for Differential Output Signals

The differential output driver is summarized in the following table. With the reference load for timing measurements, the output slew rate for falling and rising edges is defined and measured between $V_{OL(AC)}$ and $V_{OH(AC)}$ for differential signals.

Table 25: Differential Output Slew Rate Definition

| Differential Output Slew Rates (Linear Signals) | | Measured | | Calculation |
|---|---------|-------------------|-------------------|---|
| Output | Edge | From | To | |
| QKx, QKx# | Rising | $V_{OL,diff(AC)}$ | $V_{OH,diff(AC)}$ | $\frac{V_{OH,diff(AC)max} - V_{OL,diff(AC)}}{\Delta TR_{diff}}$ |
| | Falling | $V_{OH,diff(AC)}$ | $V_{OL,diff(AC)}$ | $\frac{V_{OH,diff(AC)} - V_{OL,diff(AC)}}{\Delta TF_{diff}}$ |

Figure 20: Nominal Differential Output Slew Rate Definition for QKx, QKx#

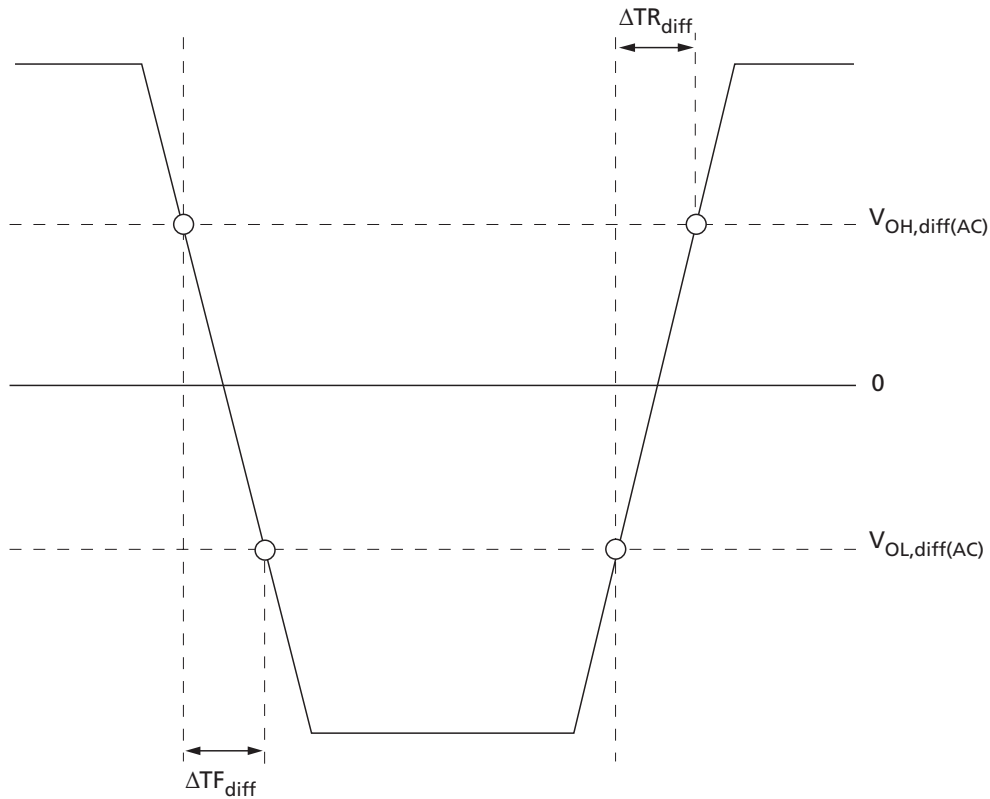



Speed Bin Tables

Table 26: RL3 2133/1866 Speed Bins

The MIN t_{CK} value for a given RL/WL parameter must be used to determine the t_{RC} mode register setting.

| Parameter | Symbol | -093E | | -093 | | -107E | | -107 | | Units |
|-------------------------|----------------|--------|-------|--------|-------|----------|-------|----------|-------|-------|
| | | Min | Max | Min | Max | Min | Max | Min | Max | |
| Clock Timing | | | | | | | | | | |
| RL = 3 ; WL = 4 | t_{CK} (avg) | 5 | 5 | 5 | 5 | Reserved | | Reserved | | ns |
| RL = 4 ; WL = 5 | t_{CK} (avg) | 4 | 5 | 4 | 5 | 4 | 5 | 4 | 5 | ns |
| RL = 5 ; WL = 6 | t_{CK} (avg) | 3 | 4.3 | 3 | 4.3 | 3.5 | 4.3 | 4 | 4.3 | ns |
| RL = 6 ; WL = 7 | t_{CK} (avg) | 2.5 | 3.5 | 2.5 | 4 | 3 | 3.5 | 3 | 4.3 | ns |
| RL = 7 ; WL = 8 | t_{CK} (avg) | 2.5 | 3 | 2.5 | 3 | 2.5 | 3 | 2.5 | 3 | ns |
| RL = 8 ; WL = 9 | t_{CK} (avg) | 1.875 | 2.5 | 1.875 | 3 | 2 | 2.5 | 2 | 3 | ns |
| RL = 9 ; WL = 10 | t_{CK} (avg) | 1.875 | 2 | 1.875 | 2 | 1.875 | 2 | 1.875 | 2 | ns |
| RL = 10 ; WL = 11 | t_{CK} (avg) | 1.5 | 2 | 1.5 | 2 | 1.875 | 2 | 1.875 | 2 | ns |
| RL = 11 ; WL = 12 | t_{CK} (avg) | 1.5 | 1.875 | 1.5 | 2 | 1.5 | 1.875 | 1.5 | 2 | ns |
| RL = 12 ; WL = 13 | t_{CK} (avg) | 1.25 | 1.5 | 1.25 | 1.875 | 1.5 | 1.66 | 1.5 | 1.875 | ns |
| RL = 13 ; WL = 14 | t_{CK} (avg) | 1.25 | 1.5 | 1.25 | 1.5 | 1.25 | 1.5 | 1.25 | 1.5 | ns |
| RL = 14 ; WL = 15 | t_{CK} (avg) | 1.07 | 1.25 | 1.07 | 1.5 | 1.25 | 1.33 | 1.25 | 1.5 | ns |
| RL = 15 ; WL = 16 | t_{CK} (avg) | 1.0 | 1.25 | 1.0 | 1.25 | 1.07 | 1.33 | 1.07 | 1.25 | ns |
| RL = 16 ; WL = 17 | t_{CK} (avg) | 0.9375 | 1.25 | 0.9375 | 1.25 | Reserved | | Reserved | | ns |
| Row Cycle Timing | | | | | | | | | | |
| Row cycle time | t_{RC} | 8 | – | 10 | – | 8 | – | 10 | – | ns |



Table 27: RL3 1600 Speed Bins

The MIN t_{CK} value for a given RL/WL parameter must be used to determine the t_{RC} mode register setting.

| Parameter | Symbol | -125F | | 125E | | -125 | | Units |
|-------------------------|----------------|----------|------|----------|-------|----------|-------|-------|
| | | Min | Max | Min | Max | Min | Max | |
| Clock Timing | | | | | | | | |
| RL = 3 ; WL = 4 | t_{CK} (avg) | Reserved | | Reserved | | Reserved | | ns |
| RL = 4 ; WL = 5 | t_{CK} (avg) | Reserved | | 4 | 5 | 5 | 5 | ns |
| RL = 5 ; WL = 6 | t_{CK} (avg) | Reserved | | 4 | 4.3 | 4 | 5 | ns |
| RL = 6 ; WL = 7 | t_{CK} (avg) | Reserved | | 3 | 4.3 | 3.5 | 4.3 | ns |
| RL = 7 ; WL = 8 | t_{CK} (avg) | Reserved | | 2.5 | 3 | 3 | 3.5 | ns |
| RL = 8 ; WL = 9 | t_{CK} (avg) | Reserved | | 2 | 3 | 2.5 | 3 | ns |
| RL = 9 ; WL = 10 | t_{CK} (avg) | Reserved | | 1.875 | 2 | 2.33 | 2.66 | ns |
| RL = 10 ; WL = 11 | t_{CK} (avg) | Reserved | | 1.875 | 2 | 2 | 2.33 | ns |
| RL = 11 ; WL = 12 | t_{CK} (avg) | Reserved | | 1.5 | 2 | 1.875 | 2.33 | ns |
| RL = 12 ; WL = 13 | t_{CK} (avg) | 1.33 | 1.66 | 1.5 | 1.875 | 1.875 | 2 | ns |
| RL = 13 ; WL = 14 | t_{CK} (avg) | 1.25 | 1.5 | 1.25 | 1.5 | 1.5 | 1.875 | ns |
| RL = 14 ; WL = 15 | t_{CK} (avg) | Reserved | | Reserved | | 1.4 | 1.66 | ns |
| RL = 15 ; WL = 16 | t_{CK} (avg) | Reserved | | Reserved | | 1.33 | 1.66 | ns |
| RL = 16 ; WL = 17 | t_{CK} (avg) | Reserved | | Reserved | | 1.25 | 1.33 | ns |
| Row Cycle Timing | | | | | | | | |
| Row cycle time | t_{RC} | 8 | – | 10 | – | 12 | – | ns |



AC Electrical Characteristics

Table 28: AC Electrical Characteristics

Notes 1–7 apply to entire table

| Parameter | Symbol | RL3–2133 | | RL3–1866 | | RL3–1600 | | Units | Notes | |
|--|------------------------------|---|--|----------|------|----------|------|---------------|-------|--------|
| | | Min | Max | Min | Max | Min | Max | | | |
| Clock Timing | | | | | | | | | | |
| Clock period average: DLL disable mode | $t_{CK}(DLL_DIS)$ | 8 | 488 | 8 | 488 | 8 | 488 | ns | 8 | |
| Clock period average: DLL enable mode | $t_{CK}(avg)$ | See t_{CK} values in the RL3 Speed Bins table. | | | | | | ns | 9, 10 | |
| High pulse width average | $t_{CH}(avg)$ | 0.47 | 0.53 | 0.47 | 0.53 | 0.47 | 0.53 | CK | 11 | |
| Low pulse width average | $t_{CL}(avg)$ | 0.47 | 0.53 | 0.47 | 0.53 | 0.47 | 0.53 | CK | 11 | |
| Clock period jitter | DLL locked | $t_{JIT}(per)$ | –50 | 50 | –60 | 60 | –70 | 70 | ps | 12 |
| | DLL locking | $t_{JIT}(per),lck$ | –40 | 40 | –50 | 50 | –60 | 60 | ps | 12 |
| Clock absolute period | $t_{CK}(abs)$ | MIN = $t_{CK}(avg),min + t_{JIT}(per),min$; MAX = $t_{CK}(avg),max + t_{JIT}(per),max$ | | | | | | ps | | |
| Clock absolute high pulse width | $t_{CH}(abs)$ | 0.43 | – | 0.43 | – | 0.43 | – | $t_{CK}(avg)$ | 13 | |
| Clock absolute low pulse width | $t_{CL}(abs)$ | 0.43 | – | 0.43 | – | 0.43 | – | $t_{CK}(avg)$ | 14 | |
| Cycle-to-cycle jitter | DLL locked | $t_{JIT}(cc)$ | 100 | | 120 | | 140 | | ps | 15 |
| | DLL locking | $t_{JIT}(cc),lck$ | 80 | | 100 | | 120 | | ps | 15 |
| Cumulative error across | 2 cycles | $t_{ERR}(2per)$ | –74 | 74 | –88 | 88 | –103 | 103 | ps | 16 |
| | 3 cycles | $t_{ERR}(3per)$ | –87 | 87 | –105 | 105 | –122 | 122 | ps | 16 |
| | 4 cycles | $t_{ERR}(4per)$ | –97 | 97 | –117 | 117 | –136 | 136 | ps | 16 |
| | 5 cycles | $t_{ERR}(5per)$ | –105 | 105 | –126 | 126 | –147 | 147 | ps | 16 |
| | 6 cycles | $t_{ERR}(6per)$ | –111 | 111 | –133 | 133 | –155 | 155 | ps | 16 |
| | 7 cycles | $t_{ERR}(7per)$ | –116 | 116 | –139 | 139 | –163 | 163 | ps | 16 |
| | 8 cycles | $t_{ERR}(8per)$ | –121 | 121 | –145 | 145 | –169 | 169 | ps | 16 |
| | 9 cycles | $t_{ERR}(9per)$ | –125 | 125 | –150 | 150 | –175 | 175 | ps | 16 |
| | 10 cycles | $t_{ERR}(10per)$ | –128 | 128 | –154 | 154 | –180 | 180 | ps | 16 |
| | 11 cycles | $t_{ERR}(11per)$ | –132 | 132 | –158 | 158 | –184 | 184 | ps | 16 |
| | 12 cycles | $t_{ERR}(12per)$ | –134 | 134 | –161 | 161 | –188 | 188 | ps | 16 |
| | n = 13, 14 ... 49, 50 cycles | $t_{ERR}(nper)$ | $t_{ERR}(nper),min = [1 + 0.68LN(n)] \times t_{JIT}(per),min$ $t_{ERR}(nper),max = [1 + 0.68LN(n)] \times t_{JIT}(per),max$ | | | | | | ps | 16 |
| DQ Input Timing | | | | | | | | | | |
| Data setup time to DK, DK# | Base (specification) | $t_{DS}(AC150)$ | –30 | – | –15 | – | 10 | – | ps | 17, 18 |
| | V_{REF} @ 1 V/ns | | 120 | – | 135 | – | 160 | – | ps | 18, 19 |



Table 28: AC Electrical Characteristics (Continued)

Notes 1–7 apply to entire table

| Parameter | Symbol | RL3-2133 | | RL3-1866 | | RL3-1600 | | Units | Notes | |
|--|---|---------------------------------|--------------------------------|---------------------------------|--------------------------------|---------------------------------|--------------------------------|----------------------|--------|--------|
| | | Min | Max | Min | Max | Min | Max | | | |
| Data hold time from DK, DK# | Base (specification) | ^t DH(DC100) | 5 | – | 20 | – | 45 | – | ps | 17, 18 |
| | V _{REF} @ 1 V/ns | | 105 | – | 120 | – | 145 | – | ps | |
| Minimum data pulse width | ^t DIPW | 280 | – | 320 | – | 360 | – | ps | 20 | |
| DQ Output Timing | | | | | | | | | | |
| QK, QK# edge to output data edge within byte group | ^t QKQ _x | – | 75 | – | 85 | – | 100 | ps | | |
| QK, QK# edge to any output data edge within specific data word grouping (only for x36) | ^t QKQ02, ^t QKQ13 | – | 125 | – | 135 | – | 150 | ps | 22 | |
| DQ output hold time from QK, QK# | ^t QH | 0.38 | – | 0.38 | – | 0.38 | – | ^t CK(avg) | 23 | |
| DQ Low-Z time from CK, CK# | ^t LZ | –360 | 180 | –390 | 195 | –450 | 225 | ps | 24, 26 | |
| DQ High-Z time from CK, CK# | ^t HZ | – | 180 | – | 195 | – | 225 | ps | 24, 26 | |
| Input and Output Strobe Timing | | | | | | | | | | |
| DK (rising), DK# (falling) edge to/from CK (rising), CK# (falling) edge | ^t CKDK | –0.27 | 0.27 | –0.27 | 0.27 | –0.27 | 0.27 | CK | 29 | |
| DK, DK# differential input HIGH width | ^t DKH | 0.45 | 0.55 | 0.45 | 0.55 | 0.45 | 0.55 | CK | | |
| DK, DK# differential input LOW width | ^t DKL | 0.45 | 0.55 | 0.45 | 0.55 | 0.45 | 0.55 | CK | | |
| QK (rising), QK# (falling) edge to CK (rising), CK# (falling) edge | ^t CKQK | –135 – 5% ^t CK | 135 + 5% ^t CK | –140 – 5% ^t CK | 140 + 5% ^t CK | –160 – 5% ^t CK | 160 + 5% ^t CK | ps | 26 | |
| QK (rising), QK# (falling) edge to CK (rising), CK# (falling) edge with DLL disabled | ^t CKQK DLL_DIS | 1 | 10 | 1 | 10 | 1 | 10 | ns | 27 | |
| QK, QK# differential output HIGH time | ^t QKH | 0.4 | – | 0.4 | – | 0.4 | – | CK | 23 | |
| QK, QK# differential output LOW time | ^t QKL | 0.4 | – | 0.4 | – | 0.4 | – | CK | 23 | |
| QK (falling), QK# (rising) edge to QVLD edge | ^t QKVLD | – | 125 | – | 135 | – | 150 | ps | 25 | |
| Command and Address Timing | | | | | | | | | | |
| CTRL, CMD, ADDR, set-up to CK, CK# | Base (specification) | ^t IS(AC150) | 85 | – | 120 | – | 170 | – | ps | 28, 30 |
| | V _{REF} @ 1 V/ns | | 235 | – | 270 | – | 320 | – | ps | 19, 30 |



Table 28: AC Electrical Characteristics (Continued)

Notes 1–7 apply to entire table

| Parameter | Symbol | RL3-2133 | | RL3-1866 | | RL3-1600 | | Units | Notes | |
|--|------------------------------|--|-----|-----------|-----|-----------|-----|-------|-------|--------|
| | | Min | Max | Min | Max | Min | Max | | | |
| CTRL, CMD, ADDR, hold from CK,CK# | Base (specification) | $t_{IH}(DC100)$ | 65 | – | 100 | – | 120 | – | ps | 28, 30 |
| | V_{REF} @ 1 V/ns | | 165 | – | 200 | – | 220 | – | ps | 19, 30 |
| Minimum CTRL, CMD, ADDR pulse width | t_{IPW} | 470 | – | 535 | – | 560 | – | ps | 20 | |
| Row cycle time | t_{RC} | See minimum t_{RC} values in the RL3 Speed Bins table. | | | | | | ns | 21 | |
| Refresh rate | t_{REF} | 64 | – | 64 | – | 64 | – | ms | | |
| Sixteen-bank access window | t_{SAW} | 8 | – | 8 | – | 8 | – | ns | | |
| Multibank access delay | t_{MMD} | 2 | – | 2 | – | 2 | – | CK | 33 | |
| WRITE-to-READ to same address | t_{WTR} | WL + BL/2 | – | WL + BL/2 | – | WL + BL/2 | – | CK | 32 | |
| Mode register set cycle time to any command | t_{MRSC} | 12 | – | 12 | – | 12 | – | CK | | |
| READ training register minimum READ time | t_{RTRS} | 2 | – | 2 | – | 2 | – | CK | | |
| READ training register burst end to mode register set for training register exit | t_{RTRE} | 1 | – | 1 | – | 1 | – | CK | | |
| Calibration Timing | | | | | | | | | | |
| ZQCL: Long calibration time | POWER-UP and RESET operation | t_{ZQinit} | 512 | – | 512 | – | 512 | – | CK | |
| | Normal operation | t_{ZQoper} | 256 | – | 256 | – | 256 | – | CK | |
| ZQCS: Short calibration time | | t_{ZQcs} | 64 | – | 64 | – | 64 | – | CK | |
| Initialization and Reset Timing | | | | | | | | | | |
| Begin power-supply ramp to power supplies stable | | $t_{V_{DDPR}}$ | – | 200 | – | 200 | – | 200 | ms | |
| RESET# LOW to power supplies stable | | t_{RPS} | – | 200 | – | 200 | – | 200 | ms | |
| RESET# LOW to I/O and R _{TT} High-Z | | t_{IOz} | – | 20 | – | 20 | – | 20 | ns | 31 |

- Notes:
- Parameters are applicable with $0^{\circ}\text{C} \leq T_C \leq +95^{\circ}\text{C}$; $+1.28\text{V} \leq V_{DD} \leq +1.42\text{V}$, $+2.38\text{V} \leq V_{EXT} \leq +2.63\text{V}$, $+1.14\text{V} \leq V_{DDQ} \leq 1.26\text{V}$.
 - All voltages are referenced to V_{SS} .
 - The unit $t_{CK}(\text{avg})$ represents the actual $t_{CK}(\text{avg})$ of the input clock under operation. The unit CK represents one clock cycle of the input clock, counting the actual clock edges.
 - AC timing and I_{DD} tests may use a V_{IL} -to- V_{IH} swing of up to 900mV in the test environment, but input timing is still referenced to V_{REF} (except t_{IS} , t_{IH} , t_{DS} , and t_{DH} use the AC/DC trip points and CK,CK# and DKx, DKx# use their crossing points). The minimum slew rate for the input signals used to test the device is 1 V/ns for single-ended inputs and 2 V/ns for differential inputs in the range between $V_{IL(AC)}$ and $V_{IH(AC)}$.



5. All timings that use time-based values (ns, μ s, ms) should use $t_{CK(avg)}$ to determine the correct number of clocks. In the case of noninteger results, all minimum limits should be rounded up to the nearest whole integer, and all maximum limits should be rounded down to the nearest whole integer.
6. The term "strobe" refers to the DK and DK# or QK and QK# differential crossing point when DK and QK, respectively, is the rising edge. Clock, or CK, refers to the CK and CK# differential crossing point when CK is the rising edge.
7. The output load defined in Figure 18 (page 39) is used for all AC timing and slew rates. The actual test load may be different. The output signal voltage reference point is $V_{DDQ}/2$ for single-ended signals and the crossing point for differential signals.
8. When operating in DLL disable mode, ISSI does not warrant compliance with normal mode timings or functionality.
9. The clock's $t_{CK(avg)}$ is the average clock over any 200 consecutive clocks and $t_{CK(avg),min}$ is the smallest clock rate allowed, with the exception of a deviation due to clock jitter. Input clock jitter is allowed provided it does not exceed values specified and must be of a random Gaussian distribution in nature.
10. Spread spectrum is not included in the jitter specification values. However, the input clock can accommodate spread spectrum at a sweep rate in the range of 20–60 kHz with an additional 1% of $t_{CK(avg)}$ as a long-term jitter component; however, the spread spectrum may not use a clock rate below $t_{CK(avg),min}$.
11. The clock's $t_{CH(avg)}$ and $t_{CL(avg)}$ are the average half-clock period over any 200 consecutive clocks and is the smallest clock half-period allowed, with the exception of a deviation due to clock jitter. Input clock jitter is allowed provided it does not exceed values specified and must be of a random Gaussian distribution in nature.
12. The period jitter, $t_{JIT(per)}$, is the maximum deviation in the clock period from the average or nominal clock. It is allowed in either the positive or negative direction.
13. $t_{CH(abs)}$ is the absolute instantaneous clock high pulse width as measured from one rising edge to the following falling edge.
14. $t_{CL(abs)}$ is the absolute instantaneous clock low pulse width as measured from one falling edge to the following rising edge.
15. The cycle-to-cycle jitter, $t_{JIT(cc)}$, is the amount the clock period can deviate from one cycle to the next. It is important to keep cycle-to-cycle jitter at a minimum during the DLL locking time.
16. The cumulative jitter error, $t_{ERR(nper)}$, where n is the number of clocks between 2 and 50, is the amount of clock time allowed to accumulate consecutively away from the average clock over n number of clock cycles.
17. $t_{DS(base)}$ and $t_{DH(base)}$ values are for a single-ended 1 V/ns DQ slew rate and 2 V/ns differential DK, DK# slew rate.
18. These parameters are measured from a data signal (DM, DQ0, DQ1, and so forth) transition edge to its respective data strobe signal (DK, DK#) crossing.
19. The setup and hold times are listed converting the base specification values (to which derating tables apply) to V_{REF} when the slew rate is 1 V/ns. These values, with a slew rate of 1 V/ns, are for reference only.
20. Pulse width of an input signal is defined as the width between the first crossing of $V_{REF(DC)}$ and the consecutive crossing of $V_{REF(DC)}$.
21. Bits MR0[3:0] select the number of clock cycles required to satisfy the minimum t_{RC} value. Minimum t_{RC} value must be divided by the clock period and rounded up to the next whole number to determine the earliest clock edge that the subsequent command can be issued to the bank.
22. t_{QKQ02} defines the skew between QK0 and DQ[26:18] and between QK2 and DQ[8:0]. t_{QKQ13} defines the skew between QK1 and DQ[35:27] and between QK3 and DQ[17:9].
23. When the device is operated with input clock jitter, this parameter needs to be derated by the actual $t_{JIT(per)}$ (the larger of $t_{JIT(per),min}$ or $t_{JIT(per),max}$ of the input clock; output deratings are relative to the SDRAM input clock).



24. Single-ended signal parameter.
25. For x36 device this specification references the skew between the falling edge of QK0 and QK1 to QVLD0 and the falling edge of QK2 and QK3 to QVLD1.
26. The DRAM output timing is aligned to the nominal or average clock. The following output parameters must be derated by the actual jitter error when input clock jitter is present, even when within specification. This results in each parameter becoming larger. The following parameters are required to be derated by subtracting $t^{ERR(10per),max}$: $t^{CKQK (MIN)}$, and $t^{LZ (MIN)}$. The following parameters are required to be derated by subtracting $t^{ERR(10per),min}$: $t^{CKQK (MAX)}$, $t^{HZ (MAX)}$, and $t^{LZ (MAX)}$.
27. The $t^{DQSCKdll_dis}$ parameter begins RL - 1 cycles after the READ command.
28. $t^{IS(base)}$ and $t^{IH(base)}$ values are for a single-ended 1 V/ns control/command/address slew rate and 2 V/ns CK, CK# differential slew rate.
29. These parameters are measured from the input data strobe signal (DK/DK#) crossing to its respective clock signal crossing (CK/CK#). The specification values are not affected by the amount of clock jitter applied as they are relative to the clock signal crossing. These parameters should be met whether or not clock jitter is present.
30. These parameters are measured from a command/address signal transition edge to its respective clock (CK, CK#) signal crossing. The specification values are not affected by the amount of clock jitter applied as the setup and hold times are relative to the clock signal crossing that latches the command/address. These parameters should be met whether or not clock jitter is present.
31. RESET# should be LOW as soon as power starts to ramp to ensure the outputs are in High-Z. Until RESET# is LOW, the outputs are at risk of driving and could result in excessive current, depending on bus activity.
32. If t^{WTR} is violated, the data just written will not be read out when a READ command is issued to the same address. Whatever data was previously written to the address will be output with the READ command.
33. This specification is defined as any bank command (READ, WRITE, AREF) to a multi-bank command or a multi-bank command to any bank command. This specification only applies to quad bank WRITE, 3-bank AREF and 4-bank AREF commands. Dual bank WRITE, 2-bank AREF, and all single bank access commands are not bound by this specification.



Temperature and Thermal Impedance Characteristics

It is imperative that the device's temperature specifications be maintained in order to ensure that the junction temperature is in the proper operating range to meet data sheet specifications. An important way to maintain the proper junction temperature is to use the device's thermal impedances correctly. Thermal impedances are listed for the available packages.

Incorrectly using thermal impedances can produce significant errors.

The device's safe junction temperature range can be maintained when the T_C specification is not exceeded. In applications where the device's ambient temperature is too high, use of forced air and/or heat sinks may be required in order to meet the case temperature specifications.

Table 29: Temperature Limits

| Parameter | | Symbol | Min | Max | Units | Notes |
|----------------------------------|------------|--------------|-----|-----|-------|-------|
| Storage temperature | | T_{STG} | -55 | 150 | °C | 1 |
| Reliability junction temperature | Commercial | $T_{J(REL)}$ | - | 110 | °C | 2 |
| | Industrial | | - | 110 | °C | 2 |
| Operating junction temperature | Commercial | $T_{J(OP)}$ | 0 | 100 | °C | 3 |
| | Industrial | | -40 | 100 | °C | 3 |
| Operating case temperature | Commercial | T_C | 0 | 95 | °C | 4, 5 |
| | Industrial | | -40 | 95 | °C | 4, 5 |

- Notes:
1. MAX storage case temperature; T_{STG} is measured in the center of the package (see Figure 21 (page 50)). This case temperature limit is allowed to be exceeded briefly during package reflow.
 2. Temperatures greater than 110°C may cause permanent damage to the device. This is a stress rating only and functional operation of the device at or above this is not implied. Exposure to absolute maximum rating conditions for extended periods may adversely affect the reliability of the part.
 3. Junction temperature depends upon package type, cycle time, loading, ambient temperature, and airflow.
 4. MAX operating case temperature; T_C is measured in the center of the package (see Figure 21 (page 50)).
 5. Device functionality is not guaranteed if the device exceeds maximum T_C during operation.

Table 30: Thermal Impedance

| Package | Substrate | θ_{JA} (°C/W) Airflow = 0m/s | θ_{JA} (°C/W) Airflow = 1m/s | θ_{JA} (°C/W) Airflow = 2m/s | θ_{JB} (°C/W) | θ_{JC} (°C/W) |
|---------|-----------|--|--|--|----------------------|----------------------|
| FBGA | 2-layer | 39.3 | 28.8 | 25.2 | 16.3 | 2.0 |
| | 4-layer | 22.0 | 17.2 | 15.9 | 10.3 | |

- Note:
1. Thermal impedance data is based on a number of samples from multiple lots, and should be viewed as a typical number.



Figure 21: Example Temperature Test Point Location

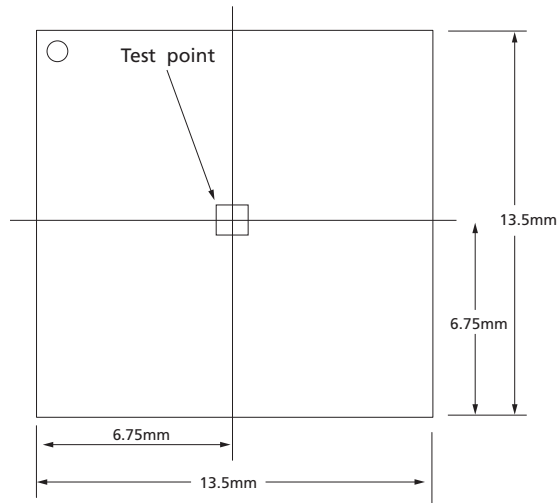



Command and Address Setup, Hold, and Derating

The total t_{IS} (setup time) and t_{IH} (hold time) required is calculated by adding the data sheet t_{IS} (base) and t_{IH} (base) values (see Table 31 (page 51); values come from Table 28 (page 44)) to the Δt_{IS} and Δt_{IH} derating values (see Table 32 (page 52)), respectively. Example: t_{IS} (total setup time) = t_{IS} (base) + Δt_{IS} . For a valid transition, the input signal must remain above/below $V_{IH(AC)}/V_{IL(AC)}$ for some time t_{VAC} (see Table 33 (page 52)).

Although the total setup time for slow slew rates might be negative (for example, a valid input signal will not have reached $V_{IH(AC)}/V_{IL(AC)}$ at the time of the rising clock transition), a valid input signal is still required to complete the transition and to reach $V_{IH(AC)}/V_{IL(AC)}$. For slew rates which fall between the values listed in Table 32 (page 52) and Table 33 (page 52) for Valid Transition, the derating values may be obtained by linear interpolation.

Setup (t_{IS}) nominal slew rate for a rising signal is defined as the slew rate between the last crossing of $V_{REF(DC)}$ and the first crossing of $V_{IH(AC)min}$. Setup (t_{IS}) nominal slew rate for a falling signal is defined as the slew rate between the last crossing of $V_{REF(DC)}$ and the first crossing of $V_{IL(AC)max}$. If the actual signal is always earlier than the nominal slew rate line between the shaded $V_{REF(DC)}$ -to-AC region, use the nominal slew rate for derating value (see Figure 22 (page 53)). If the actual signal is later than the nominal slew rate line anywhere between the shaded $V_{REF(DC)}$ -to-AC region, the slew rate of a tangent line to the actual signal from the AC level to the DC level is used for derating value (see Figure 24 (page 55)).

Hold (t_{IH}) nominal slew rate for a rising signal is defined as the slew rate between the last crossing of $V_{IL(DC)max}$ and the first crossing of $V_{REF(DC)}$. Hold (t_{IH}) nominal slew rate for a falling signal is defined as the slew rate between the last crossing of $V_{IH(DC)min}$ and the first crossing of $V_{REF(DC)}$. If the actual signal is always later than the nominal slew rate line between the shaded DC-to- $V_{REF(DC)}$ region, use the nominal slew rate for derating value (see Figure 23 (page 54)). If the actual signal is earlier than the nominal slew rate line anywhere between the shaded DC-to- $V_{REF(DC)}$ region, the slew rate of a tangent line to the actual signal from the DC level to the $V_{REF(DC)}$ level is used for derating value (see Figure 25 (page 56)).

Table 31: Command and Address Setup and Hold Values Referenced at 1 V/ns – AC/DC-Based

| Symbol | RL3-2133 | RL3-1866 | RL3-1600 | Units | Reference |
|----------------------|----------|----------|----------|-------|-------------------------|
| $t_{IS}(base),AC150$ | 85 | 120 | 170 | ps | $V_{IH(AC)}/V_{IL(AC)}$ |
| $t_{IH}(base),DC100$ | 65 | 100 | 120 | ps | $V_{IH(DC)}/V_{IL(DC)}$ |



Table 32: Derating Values for t_{IS}/t_{IH} – AC150/DC100-Based

| $\Delta t_{IS}, \Delta t_{IH}$ Derating (ps) - AC/DC-Based AC 150 Threshold: $V_{IH(AC)} = V_{REF(DC)} + 150mV, V_{IL(AC)} = V_{REF(DC)} - 150mV$ | | | | | | | | | | | | | | | | |
|---|--------------------------------|-----------------|-----------------|-----------------|-----------------|-----------------|-----------------|-----------------|-----------------|-----------------|-----------------|-----------------|-----------------|-----------------|-----------------|-----------------|
| CMD/ADDR Slew Rate (V/ns) | CK, CK# Differential Slew Rate | | | | | | | | | | | | | | | |
| | 4.0 V/ns | | 3.0 V/ns | | 2.0 V/ns | | 1.8 V/ns | | 1.6 V/ns | | 1.4 V/ns | | 1.2 V/ns | | 1.0 V/ns | |
| | Δt_{IS} | Δt_{IH} | Δt_{IS} | Δt_{IH} | Δt_{IS} | Δt_{IH} | Δt_{IS} | Δt_{IH} | Δt_{IS} | Δt_{IH} | Δt_{IS} | Δt_{IH} | Δt_{IS} | Δt_{IH} | Δt_{IS} | Δt_{IH} |
| 2.0 | 75 | 50 | 75 | 50 | 75 | 50 | 83 | 58 | 91 | 66 | 99 | 74 | 107 | 84 | 115 | 100 |
| 1.5 | 50 | 34 | 50 | 34 | 50 | 34 | 58 | 42 | 66 | 50 | 74 | 58 | 82 | 68 | 90 | 84 |
| 1.0 | 0 | 0 | 0 | 0 | 0 | 0 | 8 | 8 | 16 | 16 | 24 | 24 | 32 | 34 | 40 | 50 |
| 0.9 | 0 | -4 | 0 | -4 | 0 | -4 | 8 | 4 | 16 | 12 | 24 | 20 | 32 | 30 | 40 | 46 |
| 0.8 | 0 | -10 | 0 | -10 | 0 | -10 | 8 | -2 | 16 | 6 | 24 | 14 | 32 | 24 | 40 | 40 |
| 0.7 | 0 | -16 | 0 | -16 | 0 | -16 | 8 | -8 | 16 | 0 | 24 | 8 | 32 | 18 | 40 | 34 |
| 0.6 | -1 | -26 | -1 | -26 | -1 | -26 | 7 | -18 | 15 | -10 | 23 | -2 | 31 | 8 | 39 | 24 |
| 0.5 | -10 | -40 | -10 | -40 | -10 | -40 | -2 | -32 | 6 | -24 | 14 | -16 | 22 | -6 | 30 | 10 |
| 0.4 | -25 | -60 | -25 | -60 | -25 | -60 | -17 | -52 | -9 | -44 | -1 | -36 | 7 | -26 | 15 | -10 |

Table 33: Minimum Required Time t_{VAC} Above $V_{IH(AC)}$ (or Below $V_{IL(AC)}$) for Valid Transition

| Slew Rate (V/ns) | t_{VAC} (ps) |
|------------------|----------------|
| >2.0 | 175 |
| 2.0 | 170 |
| 1.5 | 167 |
| 1.0 | 163 |
| 0.9 | 162 |
| 0.8 | 161 |
| 0.7 | 159 |
| 0.6 | 155 |
| 0.5 | 150 |
| <0.5 | 150 |

Figure 22: Nominal Slew Rate and t_{VAC} for t_{IS} (Command and Address - Clock)

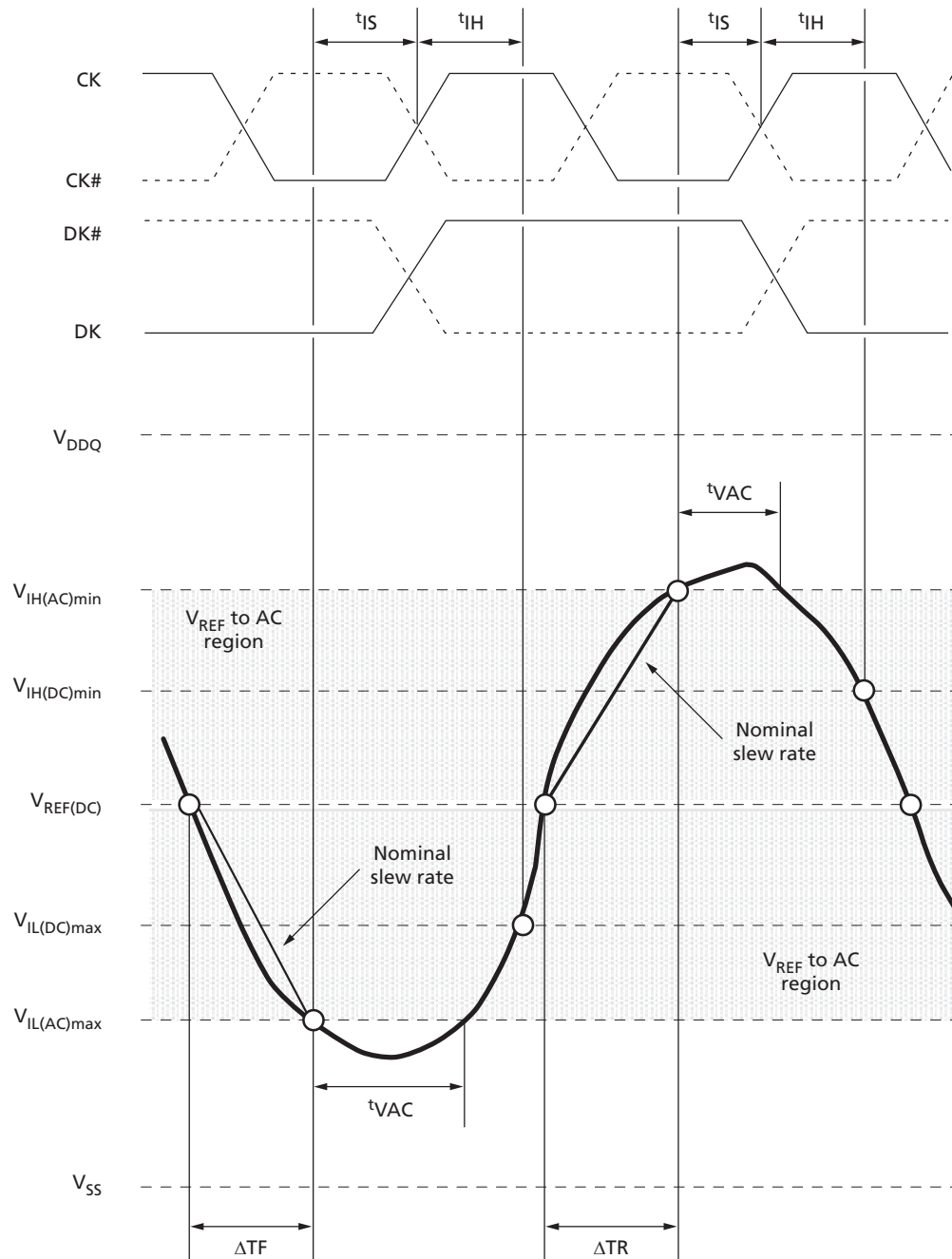

$$\text{Setup slew rate falling signal} = \frac{V_{REF(DC)} - V_{IL(AC)max}}{\Delta TF}$$

$$\text{Setup slew rate rising signal} = \frac{V_{IH(AC)min} - V_{REF(DC)}}{\Delta TR}$$

Note: 1. Both the clock and the data strobe are drawn on different time scales.

Figure 23: Nominal Slew Rate for t_{IH} (Command and Address - Clock)

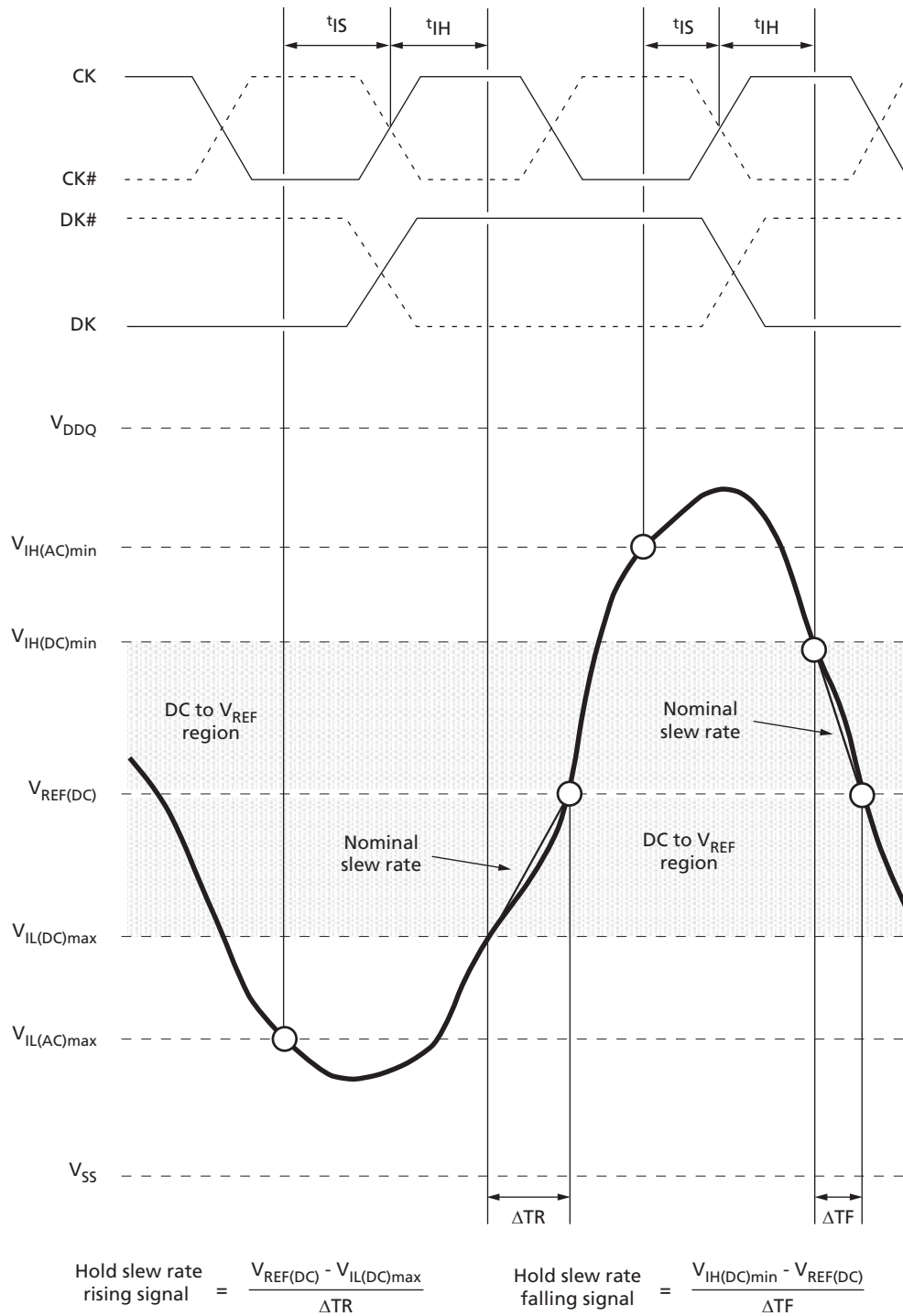

Note: 1. Both the clock and the data strobe are drawn on different time scales.

Figure 24: Tangent Line for t_{IS} (Command and Address - Clock)

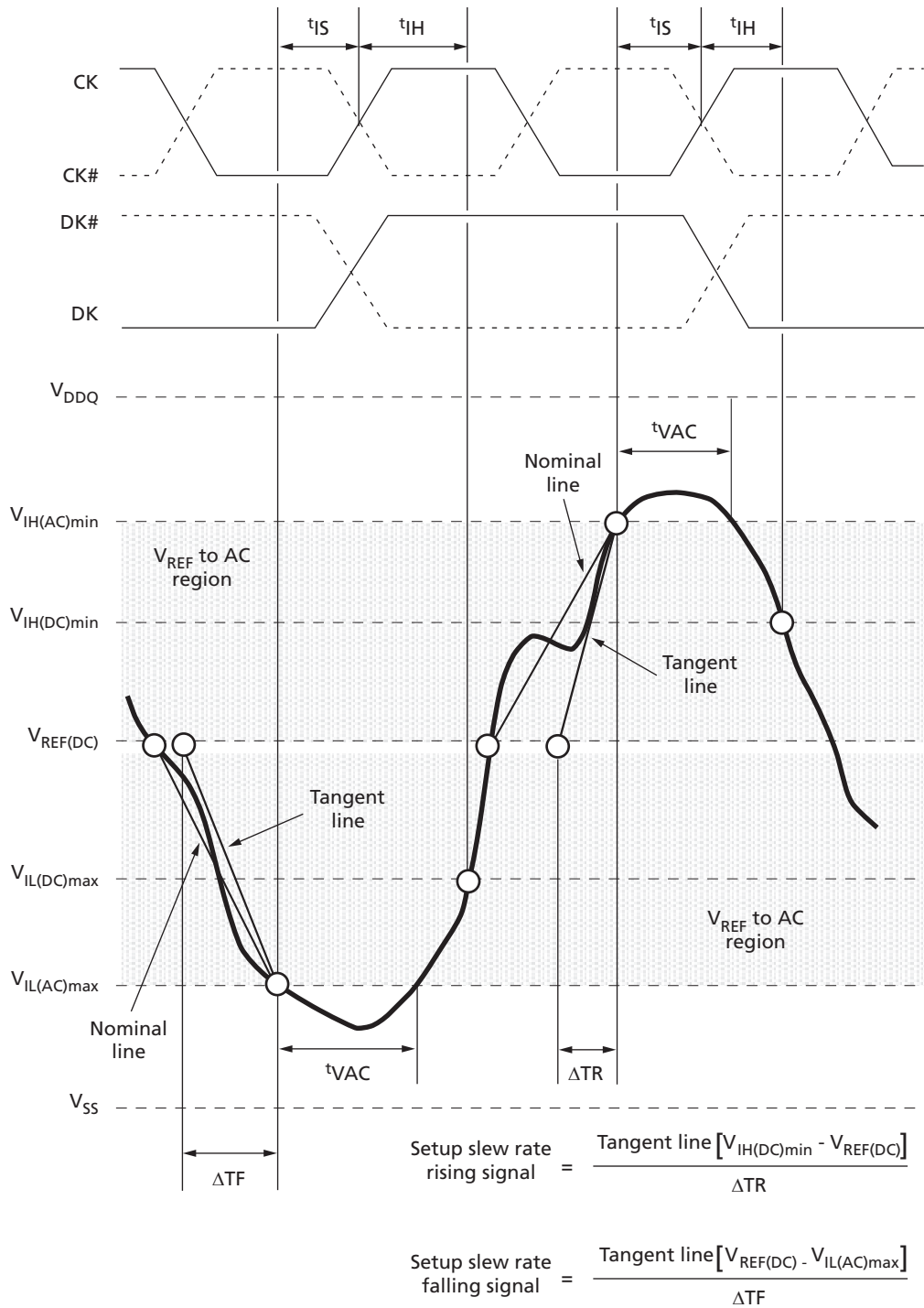

Note: 1. Both the clock and the data strobe are drawn on different time scales.

Figure 25: Tangent Line for t_{IH} (Command and Address - Clock)

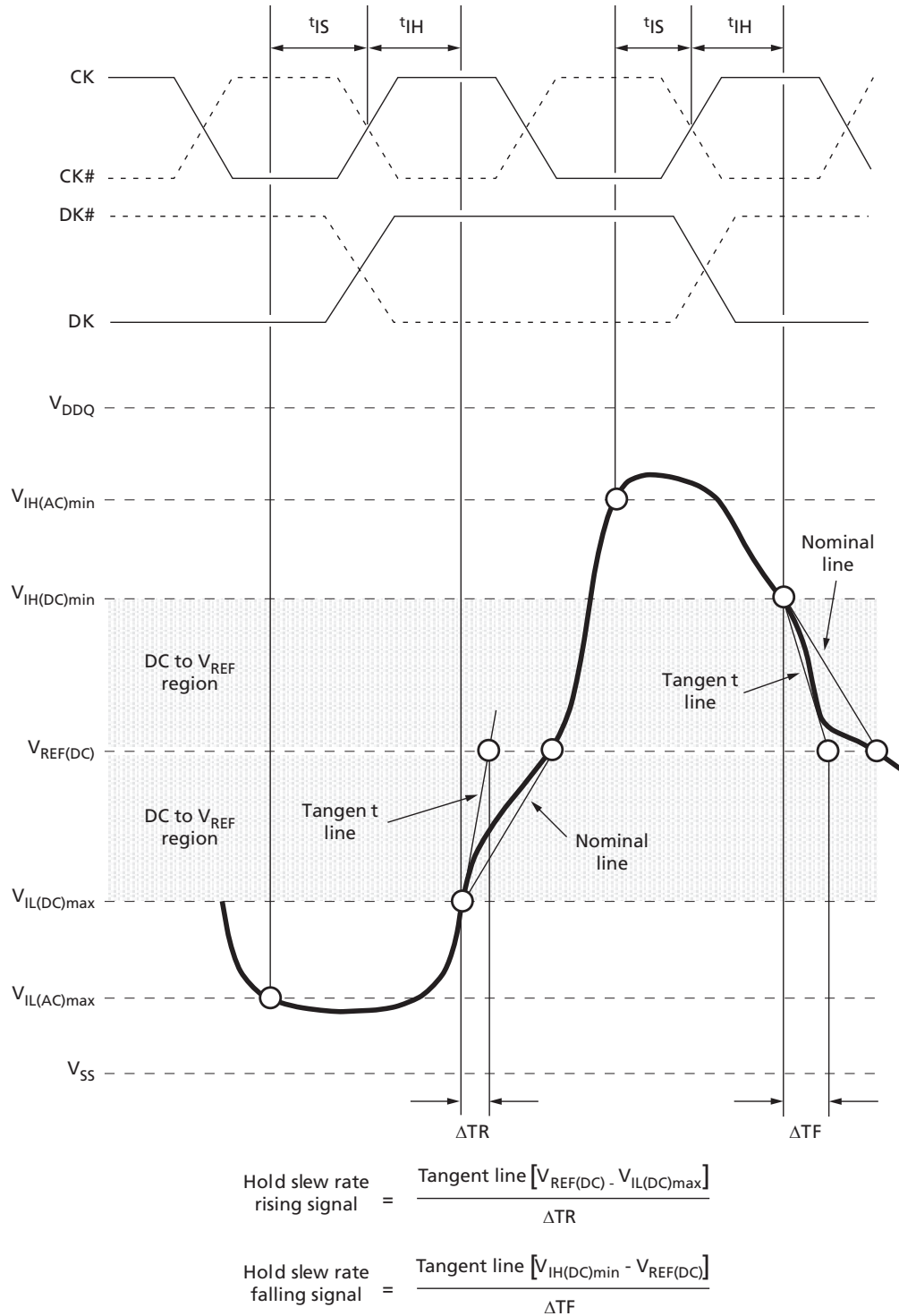

Note: 1. Both the clock and the data strobe are drawn on different time scales.



Data Setup, Hold, and Derating

The total t_{DS} (setup time) and t_{DH} (hold time) required is calculated by adding the data sheet t_{DS} (base) and t_{DH} (base) values (see the table below; values come from Table 28 (page 44)) to the Δt_{DS} and Δt_{DH} derating values (see Table 35 (page 58)), respectively. Example: t_{DS} (total setup time) = t_{DS} (base) + Δt_{DS} . For a valid transition, the input signal has to remain above/below $V_{IH(AC)}/V_{IL(AC)}$ for some time t_{VAC} (see Table 36 (page 58)).

Although the total setup time for slow slew rates might be negative (for example, a valid input signal will not have reached $V_{IH(AC)}/V_{IL(AC)}$ at the time of the rising clock transition), a valid input signal is still required to complete the transition and to reach $V_{IH}/V_{IL(AC)}$. For slew rates which fall between the values listed in Table 35 (page 58) and Table 36 (page 58), the derating values may be obtained by linear interpolation.

Setup (t_{DS}) nominal slew rate for a rising signal is defined as the slew rate between the last crossing of $V_{REF(DC)}$ and the first crossing of $V_{IH(AC)min}$. Setup (t_{DS}) nominal slew rate for a falling signal is defined as the slew rate between the last crossing of $V_{REF(DC)}$ and the first crossing of $V_{IL(AC)max}$. If the actual signal is always earlier than the nominal slew rate line between the shaded $V_{REF(DC)}$ -to-AC region, use the nominal slew rate for derating value (see Figure 26 (page 59)). If the actual signal is later than the nominal slew rate line anywhere between the shaded $V_{REF(DC)}$ -to-AC region, the slew rate of a tangent line to the actual signal from the AC level to the DC level is used for derating value (see Figure 28 (page 61)).

Hold (t_{DH}) nominal slew rate for a rising signal is defined as the slew rate between the last crossing of $V_{IL(DC)max}$ and the first crossing of $V_{REF(DC)}$. Hold (t_{DH}) nominal slew rate for a falling signal is defined as the slew rate between the last crossing of $V_{IH(DC)min}$ and the first crossing of $V_{REF(DC)}$. If the actual signal is always later than the nominal slew rate line between the shaded DC-to- $V_{REF(DC)}$ region, use the nominal slew rate for derating value (see Figure 27 (page 60)). If the actual signal is earlier than the nominal slew rate line anywhere between the shaded DC-to- $V_{REF(DC)}$ region, the slew rate of a tangent line to the actual signal from the DC-to- $V_{REF(DC)}$ region is used for derating value (see Figure 29 (page 62)).

Table 34: Data Setup and Hold Values at 1 V/ns (DKx, DKx# at 2V/ns) – AC/DC-Based

| Symbol | RL3-2133 | RL3-1866 | RL3-1600 | Units | Reference |
|----------------------|----------|----------|----------|-------|-------------------------|
| $t_{DS(base),AC150}$ | -30 | -15 | 10 | ps | $V_{IH(AC)}/V_{IL(AC)}$ |
| $t_{DH(base),DC100}$ | 5 | 20 | 45 | ps | $V_{IH(DC)}/V_{IL(DC)}$ |



Table 35: Derating Values for t_{DS}/t_{DH} – AC150/DC100-Based

Empty cells indicate slew rate combinations not supported

| $\Delta t_{DS}, \Delta t_{DH}$ Derating (ps) - AC/DC-Based | | | | | | | | | | | | | | | | |
|--|----------------------------------|-----------------|-----------------|-----------------|-----------------|-----------------|-----------------|-----------------|-----------------|-----------------|-----------------|-----------------|-----------------|-----------------|-----------------|-----------------|
| DQ Slew Rate (V/ns) | DKx, DKx# Differential Slew Rate | | | | | | | | | | | | | | | |
| | 4.0 V/ns | | 3.0 V/ns | | 2.0 V/ns | | 1.8 V/ns | | 1.6 V/ns | | 1.4 V/ns | | 1.2 V/ns | | 1.0 V/ns | |
| | Δt_{DS} | Δt_{DH} | Δt_{DS} | Δt_{DH} | Δt_{DS} | Δt_{DH} | Δt_{DS} | Δt_{DH} | Δt_{DS} | Δt_{DH} | Δt_{DS} | Δt_{DH} | Δt_{DS} | Δt_{DH} | Δt_{DS} | Δt_{DH} |
| 2.0 | 75 | 50 | 75 | 50 | 75 | 50 | | | | | | | | | | |
| 1.5 | 50 | 34 | 50 | 34 | 50 | 34 | 58 | 42 | | | | | | | | |
| 1.0 | 0 | 0 | 0 | 0 | 0 | 0 | 8 | 8 | 16 | 16 | | | | | | |
| 0.9 | | | 0 | -4 | 0 | -4 | 8 | 4 | 16 | 12 | 24 | 20 | | | | |
| 0.8 | | | | | 0 | -10 | 8 | -2 | 16 | 6 | 24 | 14 | 32 | 24 | | |
| 0.7 | | | | | | | 8 | -8 | 16 | 0 | 24 | 8 | 32 | 18 | 40 | 34 |
| 0.6 | | | | | | | | | 15 | -10 | 23 | -2 | 31 | 8 | 39 | 24 |
| 0.5 | | | | | | | | | | | 14 | -16 | 22 | -6 | 30 | 10 |
| 0.4 | | | | | | | | | | | | | 7 | -26 | 15 | -10 |

Table 36: Minimum Required Time t_{VAC} Above $V_{IH(AC)}$ (or Below $V_{IL(AC)}$) for Valid Transition

| Slew Rate (V/ns) | t_{VAC} (ps) |
|------------------|----------------|
| >2.0 | 175 |
| 2.0 | 170 |
| 1.5 | 167 |
| 1.0 | 163 |
| 0.9 | 162 |
| 0.8 | 161 |
| 0.7 | 159 |
| 0.6 | 155 |
| 0.5 | 150 |
| <0.5 | 150 |

Figure 26: Nominal Slew Rate and t_{VAC} for t_{DS} (DQ - Strobe)

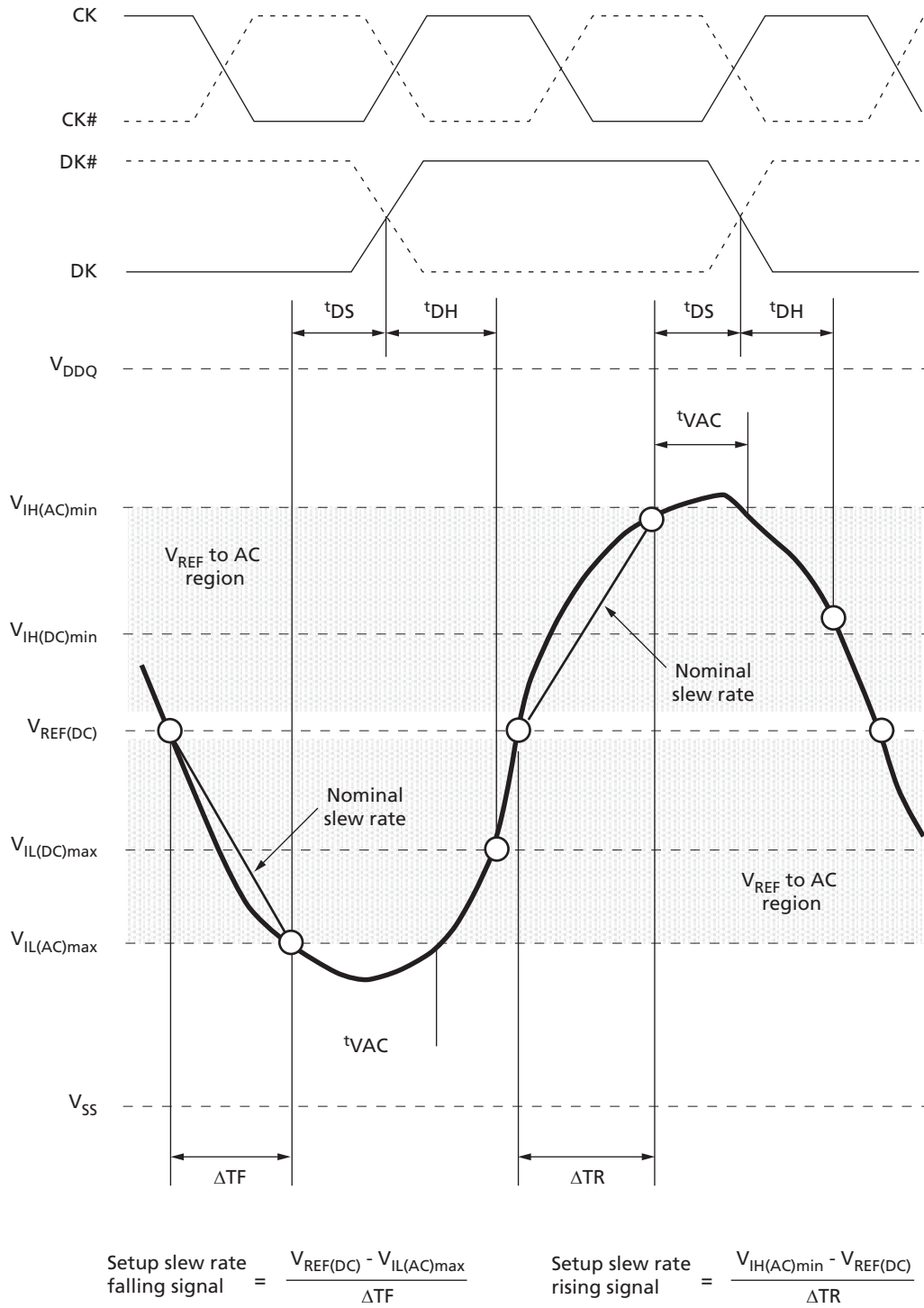

Note: 1. Both the clock and the strobe are drawn on different time scales.

Figure 27: Nominal Slew Rate for t_{DH} (DQ - Strobe)

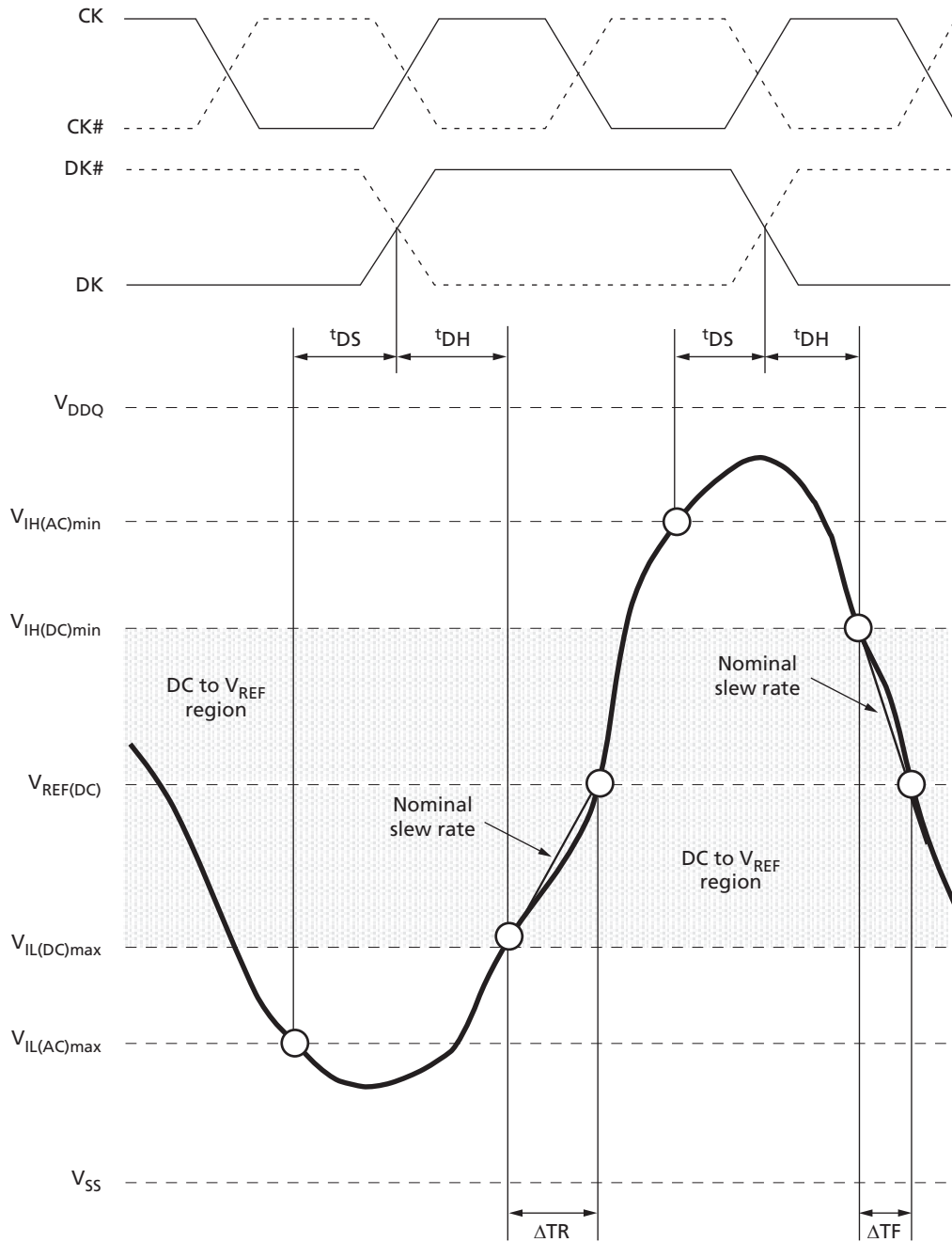

$$\text{Hold slew rate rising signal} = \frac{V_{REF(DC)} - V_{IL(DC)max}}{\Delta TR}$$

$$\text{Hold slew rate falling signal} = \frac{V_{IH(DC)min} - V_{REF(DC)}}{\Delta TF}$$

Note: 1. Both the clock and the strobe are drawn on different time scales.

Figure 28: Tangent Line for t_{DS} (DQ - Strobe)

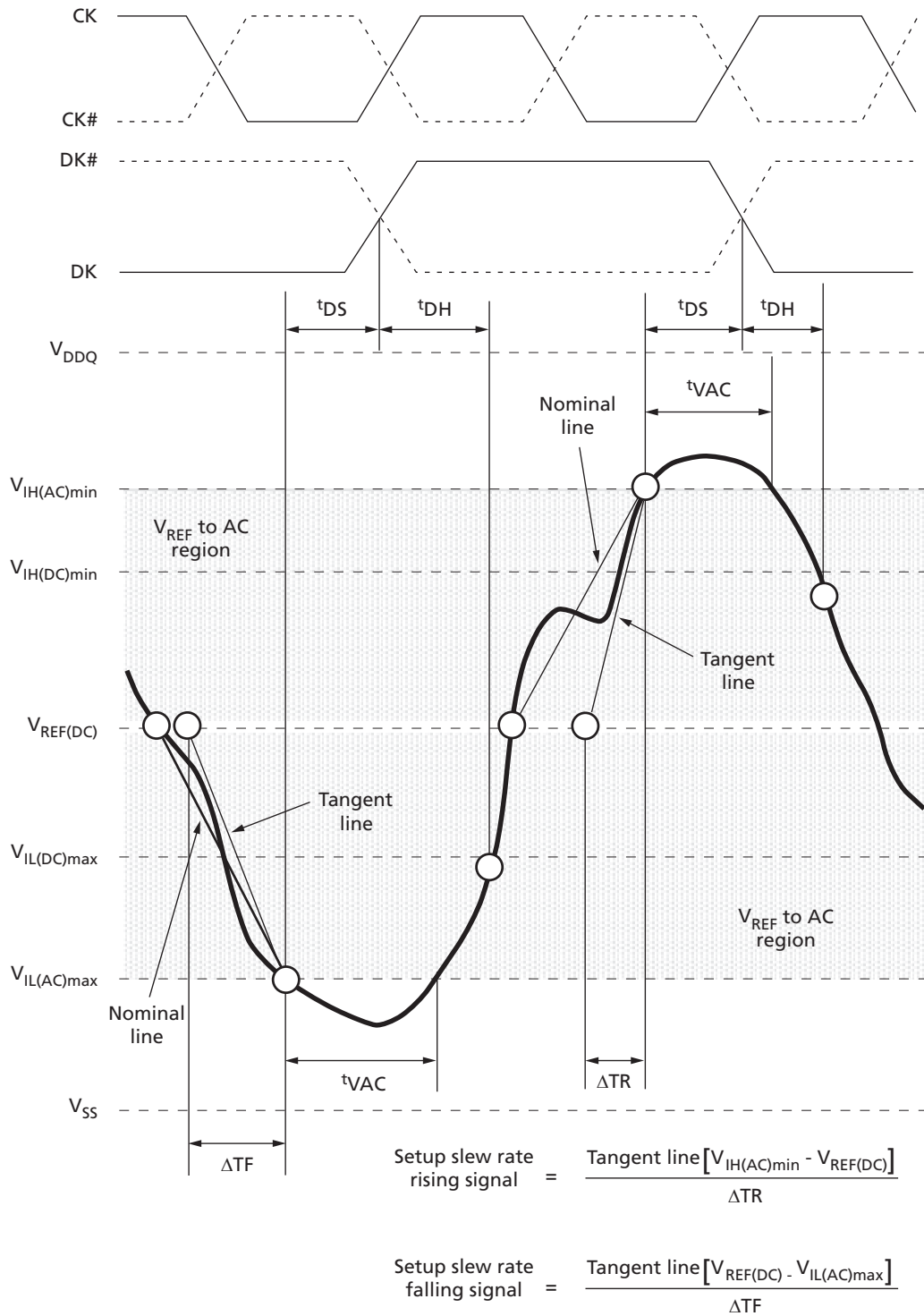

Note: 1. Both the clock and the strobe are drawn on different time scales.

Figure 29: Tangent Line for t_{DH} (DQ - Strobe)

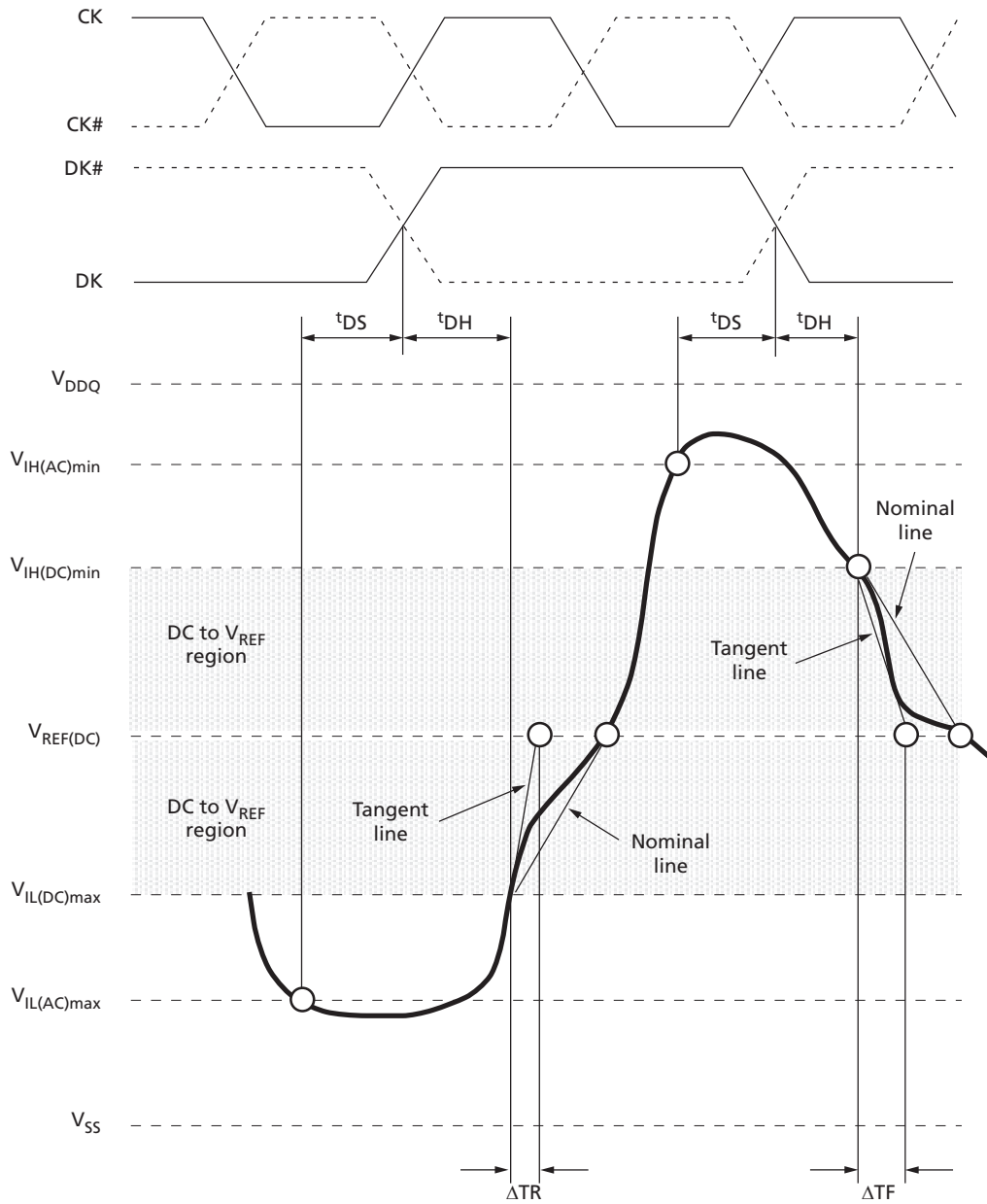

$$\text{Hold slew rate rising signal} = \frac{\text{Tangent line} [V_{REF(DC)} - V_{IL(DC)max}]}{\Delta TR}$$

$$\text{Hold slew rate falling signal} = \frac{\text{Tangent line} [V_{IH(DC)min} - V_{REF(DC)}]}{\Delta TF}$$

Note: 1. Both the clock and the strobe are drawn on different time scales.



Commands

The following table provides descriptions of the valid commands of the RLD RAM 3 device. All command and address inputs must meet setup and hold times with respect to the rising edge of CK.

Table 37: Command Descriptions

| Command | Description |
|---------|--|
| NOP | The NOP command prevents new commands from being executed by the DRAM. Operations already in progress are not affected by NOP commands. Output values depend on command history. |
| MRS | Mode registers MR0, MR1, and MR2 are used to define various modes of programmable operations of the DRAM. A mode register is programmed via the MODE REGISTER SET (MRS) command during initialization and retains the stored information until it is reprogrammed, RESET# goes LOW, or until the device loses power. The MRS command can be issued only when all banks are idle, and no bursts are in progress. |
| READ | The READ command is used to initiate a burst read access to a bank. The BA[3:0] inputs select a bank, and the address provided on inputs A[19:0] select a specific location within a bank. |
| WRITE | The WRITE command is used to initiate a burst write access to a bank (or banks). MRS bits MR2[4:3] select single, dual, or quad bank WRITE protocol. The BA[x:0] inputs select the bank(s) (x = 3, 2, or 1 for single, dual, or quad bank WRITE, respectively). The address provided on inputs A[19:0] select a specific location within the bank. Input data appearing on the DQ is written to the memory array subject to the DM input logic level appearing coincident with the data. If the DM signal is registered LOW, the corresponding data will be written to memory. If the DM signal is registered HIGH, the corresponding data inputs will be ignored (that is, this part of the data word will not be written). |
| AREF | The AREF command is used during normal operation of the RLD RAM 3 to refresh the memory content of a bank. There are two methods by which the RLD RAM 3 can be refreshed, both of which are selected within the mode register. The first method, bank address-controlled AREF, is identical to the method used in RLD RAM2. The second method, multibank AREF, enables refreshing of up to four banks simultaneously. More info is available in the Auto Refresh section. For both methods, the command is nonpersistent, so it must be issued each time a refresh is required. |

Table 38: Command Table

Note 1 applies to the entire table

| Operation | Code | CS# | WE# | REF# | A[19:0] | BA[3:0] | Notes |
|--------------|-------|-----|-----|------|---------|---------|-------|
| NOP | NOP | H | H | H | X | X | |
| MRS | MRS | L | L | L | OPCODE | OPCODE | |
| READ | READ | L | H | H | A | BA | 2 |
| WRITE | WRITE | L | L | H | A | BA | 2 |
| AUTO REFRESH | AREF | L | H | L | A | BA | 3 |

- Notes:
1. X = "Don't Care;" H = logic HIGH; L = logic LOW; A = valid address; BA = valid bank address; OPCODE = mode register bits
 2. Address width varies with burst length and configuration; see the Address Widths of Different Burst Lengths table for more information.
 3. Bank address signals (BA) are used only during bank address-controlled AREF; Address signals (A) are used only during multibank AREF.

MODE REGISTER SET (MRS) Command

The mode registers, MR0, MR1, and MR2, store the data for controlling the operating modes of the memory. The MODE REGISTER SET (MRS) command programs the RLD RAM 3 operating modes and I/O options. During an MRS command, the address inputs are sampled and stored in the mode registers. The BA[1:0] signals select between mode registers 0–2 (MR0–MR2). After the MRS command is issued, each mode register retains the stored information until it is reprogrammed, until RESET# goes LOW, or until the device loses power.

After issuing a valid MRS command, ^tMRSC must be met before any command can be issued to the RLD RAM 3. The MRS command can be issued only when all banks are idle, and no bursts are in progress.

Figure 30: MRS Command Protocol

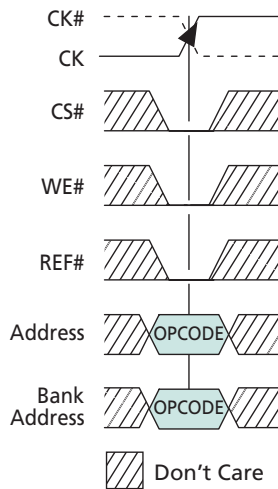

Mode Register 0 (MR0)

Figure 31: MR0 Definition for Non-Multiplexed Address Mode

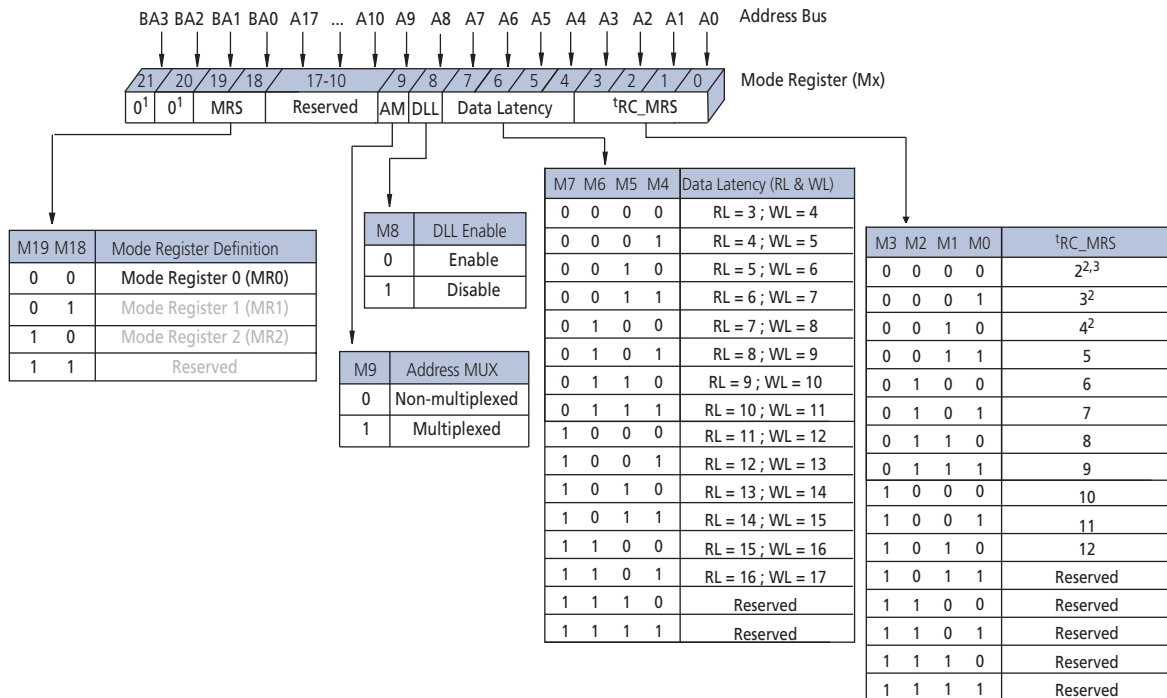

- Notes:
1. BA2, BA3, and all address balls corresponding to reserved bits must be held LOW during the MRS command.
 2. BL8 not allowed.
 3. BL4 not allowed.



t^{RC}

Bits MR0[3:0] select the number of clock cycles required to satisfy the t^{RC} specifications.

After a READ, WRITE, or AREF command is issued to a bank, a subsequent READ, WRITE, or AREF cannot be issued to the same bank until t^{RC} has been satisfied. The correct value (t^{RC}_MRS) to program into MR0[3:0] is shown in the table below.

Table 39: t^{RC}_MRS MR0[3:0] values

| Parameter | -093E | -093 | -107E | -107 | -125F | -125E | -125 |
|------------------|-------|------|----------|----------|----------|----------|----------|
| RL = 3; WL = 4 | 2 | 2 | Reserved | Reserved | Reserved | Reserved | Reserved |
| RL = 4; WL = 5 | 2 | 3 | 2 | 3 | Reserved | 3 | 3 |
| RL = 5; WL = 6 | 3 | 4 | 3 | 3 | Reserved | 3 | 3 |
| RL = 6; WL = 7 | 4 | 4 | 3 | 4 | Reserved | 4 | 4 |
| RL = 7; WL = 8 | 4 | 4 | 4 | 4 | Reserved | 4 | 4 |
| RL = 8; WL = 9 | 5 | 6 | 4 | 5 | Reserved | 5 | 5 |
| RL = 9; WL = 10 | 5 | 6 | 5 | 6 | Reserved | 6 | 6 |
| RL = 10; WL = 11 | 6 | 7 | 5 | 6 | Reserved | 6 | 6 |
| RL = 11; WL = 12 | 6 | 7 | 6 | 7 | Reserved | 7 | 7 |
| RL = 12; WL = 13 | 7 | 8 | 6 | 7 | 6 | 7 | 7 |
| RL = 13; WL = 14 | 7 | 8 | 7 | 8 | 7 | 8 | 8 |
| RL = 14; WL = 15 | 8 | 10 | 7 | 8 | Reserved | Reserved | 9 |
| RL = 15; WL = 16 | 8 | 10 | 8 | 10 | Reserved | Reserved | 10 |
| RL = 16; WL = 17 | 9 | 11 | Reserved | Reserved | Reserved | Reserved | 10 |

Data Latency

The data latency register uses MR0[7:4] to set both the READ and WRITE latency (RL and WL). The valid operating frequencies for each data latency register setting can be found in Table 28 (page 44).

DLL Enable/Disable

Through the programming of MR0[8], the DLL can be enabled or disabled.

The DLL must be enabled for normal operation. The DLL must be enabled during the initialization routine and upon returning to normal operation after having been disabled for the purpose of debugging or evaluation. To operate the RLD RAM with the DLL disabled, the t^{RC} MRS setting must equal the read latency (RL) setting. Enabling the DLL should always be followed by resetting the DLL using the appropriate MR1 command.

Address Multiplexing

Although the RLD RAM has the ability to operate similar to an SRAM interface by accepting the entire address in one clock (non-multiplexed, or broadside addressing), MR0[9] can be set to 1 so that it functions with multiplexed addressing, similar to a traditional DRAM. In multiplexed address mode, the address is provided to the RLD RAM in two parts that are latched into the memory with two consecutive rising edges of CK.



When in multiplexed address mode, only 11 address balls are required to control the RLD RAM, as opposed to 20 address balls when in non-multiplexed address mode. The data bus efficiency in continuous burst mode is only affected when using the BL = 2 setting because the device requires two clocks to read and write data. During multiplexed mode, the bank addresses as well as WRITE and READ commands are issued during the first address part, Ax. The Address Mapping in Multiplexed Address Mode table shows the addresses needed for both the first and second rising clock edges (Ax and Ay, respectively).

After MR0[9] is set HIGH, READ, WRITE, and MRS commands follow the format described in the Command Description in Multiplexed Address Mode figure. Refer to Multiplexed Address Mode for further information on operation with multiplexed addressing.

Mode Register 1 (MR1)

Figure 32: MR1 Definition for Non-Multiplexed Address Mode

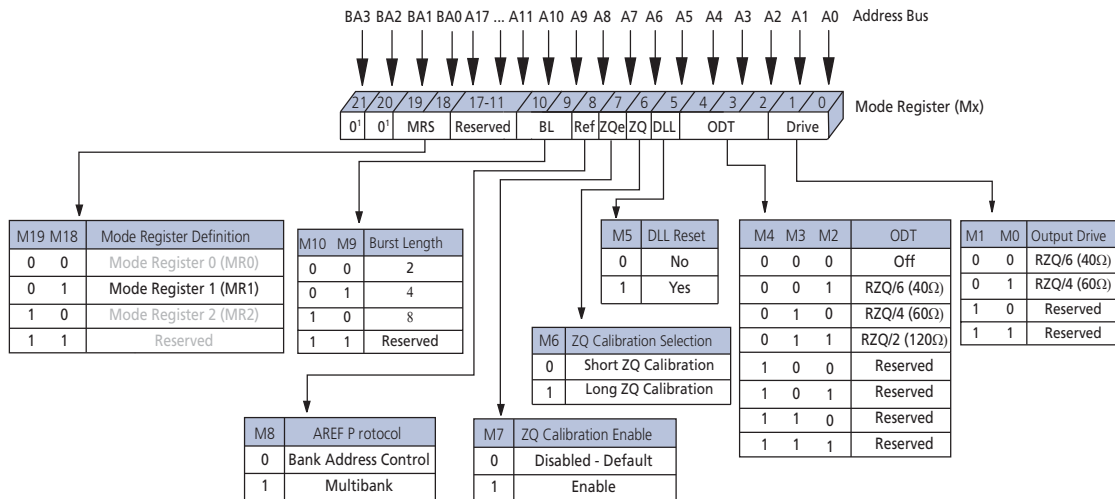

- Notes:
1. BA2, BA3, and all address balls corresponding to reserved bits must be held LOW during the MRS command.
 2. BL8 not available in x36.

Output Drive Impedance

The RLD RAM 3 uses programmable impedance output buffers, which enable the user to match the driver impedance to the system. MR1[0] and MR1[1] are used to select 40Ω or 60Ω output impedance, but the device powers up with an output impedance of 40Ω. The drivers have symmetrical output impedance. To calibrate the impedance a 240Ω ±1% external precision resistor (RZQ) is connected between the ZQ ball and V_{SSQ}.

The output impedance is calibrated during initialization through the ZQCL mode register setting. Subsequent periodic calibrations (ZQCS) may be performed to compensate for shifts in output impedance due to changes in temperature and voltage. More detailed information on calibration can be found in the ZQ Calibration section.

DQ On-Die Termination (ODT)

MR1[4:2] are used to select the value of the on-die termination (ODT) for the DQ, DK_x and DM balls. When enabled, ODT terminates these balls to V_{DDQ}/2. The RLD RAM 3 device supports 40Ω, 60Ω, or 120Ω ODT. The ODT function is dynamically switched off when a DQ begins to drive after a READ command has been issued. Similarly, ODT is designed to switch on at the DQs after the RLD RAM has issued the last piece of data. The DM and DK_x balls are always terminated after ODT is enabled.

DLL Reset

Programming MR1[5] to 1 activates the DLL RESET function. MR1[5] is self-clearing, meaning it returns to a value of 0 after the DLL RESET function has been initiated.



Whenever the DLL RESET function is initiated, CK/CK# must be held stable for 512 clock cycles before a READ command can be issued. This is to allow time for the internal clock to be synchronized with the external clock. Failing to wait for synchronization to occur may cause output timing specifications, such as t_{CKQK} , to be invalid.

ZQ Calibration

The ZQ CALIBRATION mode register command is used to calibrate the DRAM output drivers (R_{ON}) and ODT values (R_{TT}) over process, voltage, and temperature, provided a dedicated 240Ω ($\pm 1\%$) external resistor is connected from the DRAM's RZQ ball to V_{SSQ} . Bit MR1[6] selects between ZQ calibration long (ZQCL) and ZQ calibration short (ZQCS), each of which are described in detail below. When bit MR1[7] is set HIGH, it enables the calibration sequence. Upon completion of the ZQ calibration sequence, MR1[7] automatically resets LOW.

The RLD RAM 3 needs a longer time to calibrate R_{ON} and ODT at power-up initialization and a relatively shorter time to perform periodic calibrations. An example of ZQ calibration timing is shown below.

All banks must have t_{RC} met before ZQCL or ZQCS mode register settings can be issued to the DRAM. No other activities (other than loading another ZQCL or ZQCS mode register setting may be issued to another DRAM) can be performed on the DRAM channel by the controller for the duration of t_{ZQinit} or t_{ZQoper} . The quiet time on the DRAM channel helps accurately calibrate R_{ON} and ODT. After DRAM calibration is achieved, the DRAM will disable the ZQ ball's current consumption path to reduce power.

ZQ CALIBRATION mode register settings can be loaded in parallel to DLL reset and locking time.

In systems that share the ZQ resistor between devices, the controller must not allow overlap of t_{ZQinit} , t_{ZQoper} , or t_{ZQcs} between devices.

Figure 33: ZQ Calibration Timing (ZQCL and ZQCS)

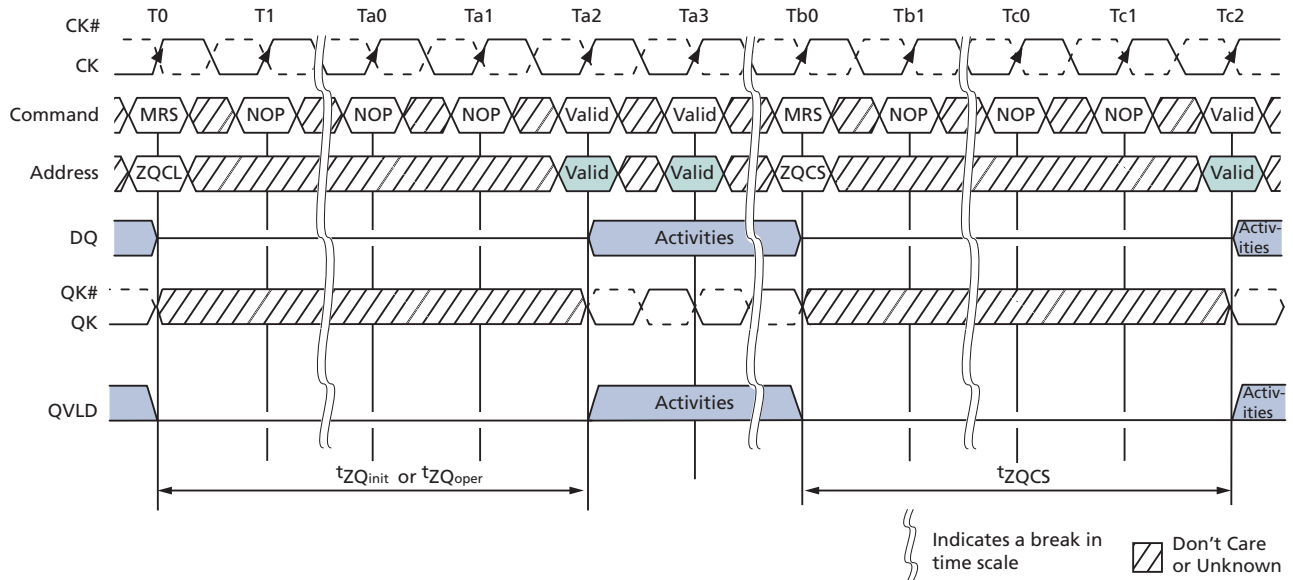

- Notes:
1. All devices connected to the DQ bus should be held High-Z during calibration.
 2. The state of QK and QK# are unknown during ZQ calibration.
 3. t_{MRSC} after loading the MR1 settings, QVLD output drive strength will be at the value selected or higher (lower resistance) until ZQ calibration is complete.

ZQ Calibration Long

The ZQ calibration long (ZQCL) mode register setting is used to perform the initial calibration during a power-up initialization and reset sequence. It may be loaded at any time by the controller depending on the system environment. ZQCL triggers the calibration engine inside the DRAM. After calibration is achieved, the calibrated values are transferred from the calibration engine to the DRAM I/O, which are reflected as updated R_{ON} and ODT values.

The DRAM is allowed a timing window defined by either t_{ZQinit} or t_{ZQoper} to perform the full calibration and transfer of values. When ZQCL is issued during the initialization sequence, the timing parameter t_{ZQinit} must be satisfied. When initialization is complete, subsequent loading of the ZQCL mode register setting requires the timing parameter t_{ZQoper} to be satisfied.

ZQ Calibration Short

The ZQ calibration short (ZQCS) mode register setting is used to perform periodic calibrations to account for small voltage and temperature variations. The shorter timing window is provided to perform the reduced calibration and transfer of values as defined by timing parameter t_{ZQCS} . ZQCS can effectively correct a minimum of 0.5% R_{ON} and R_{TT} impedance error within 64 clock cycles, assuming the maximum sensitivities specified in the ODT Temperature and Voltage Sensitivity and the Output Driver Voltage and Temperature Sensitivity tables.



AUTO REFRESH Protocol

The AUTO REFRESH (AREF) protocol is selected with bit MR1[8]. There are two ways in which AREF commands can be issued to the RLD RAM. Depending upon how bit MR1[8] is programmed, the memory controller can issue either bank address-controlled or multibank AREF commands. Bank address-controlled AREF uses the BA[3:0] inputs to refresh a single bank per command. Multibank AREF is enabled by setting bit MR1[8] HIGH during an MRS command. This refresh protocol enables the simultaneous refreshing of a row in up to four banks. In this method, the address pins A[15:0] represent banks 0–15, respectively. More information on both AREF protocols can be found in AUTO REFRESH Command (page 78).

Burst Length (BL)

Burst length is defined by MR1[9] and MR1[10]. Read and write accesses to the RLD RAM are burst-oriented, with the burst length being programmable to 2, 4, or 8. Figure 34 (page 72) shows the different burst lengths with respect to a READ command. Changes in the burst length affect the width of the address bus (see the following table for details).

The data written by the prior burst length is not guaranteed to be accurate when the burst length of the device is changed.

Table 40: Address Widths of Different Burst Lengths

| Burst Length | Configuration | |
|--------------|---------------|---------|
| | x18 | x36 |
| 2 | A[19:0] | A[18:0] |
| 4 | A[18:0] | A[17:0] |
| 8 | A[17:0] | NA |

Figure 34: Read Burst Lengths

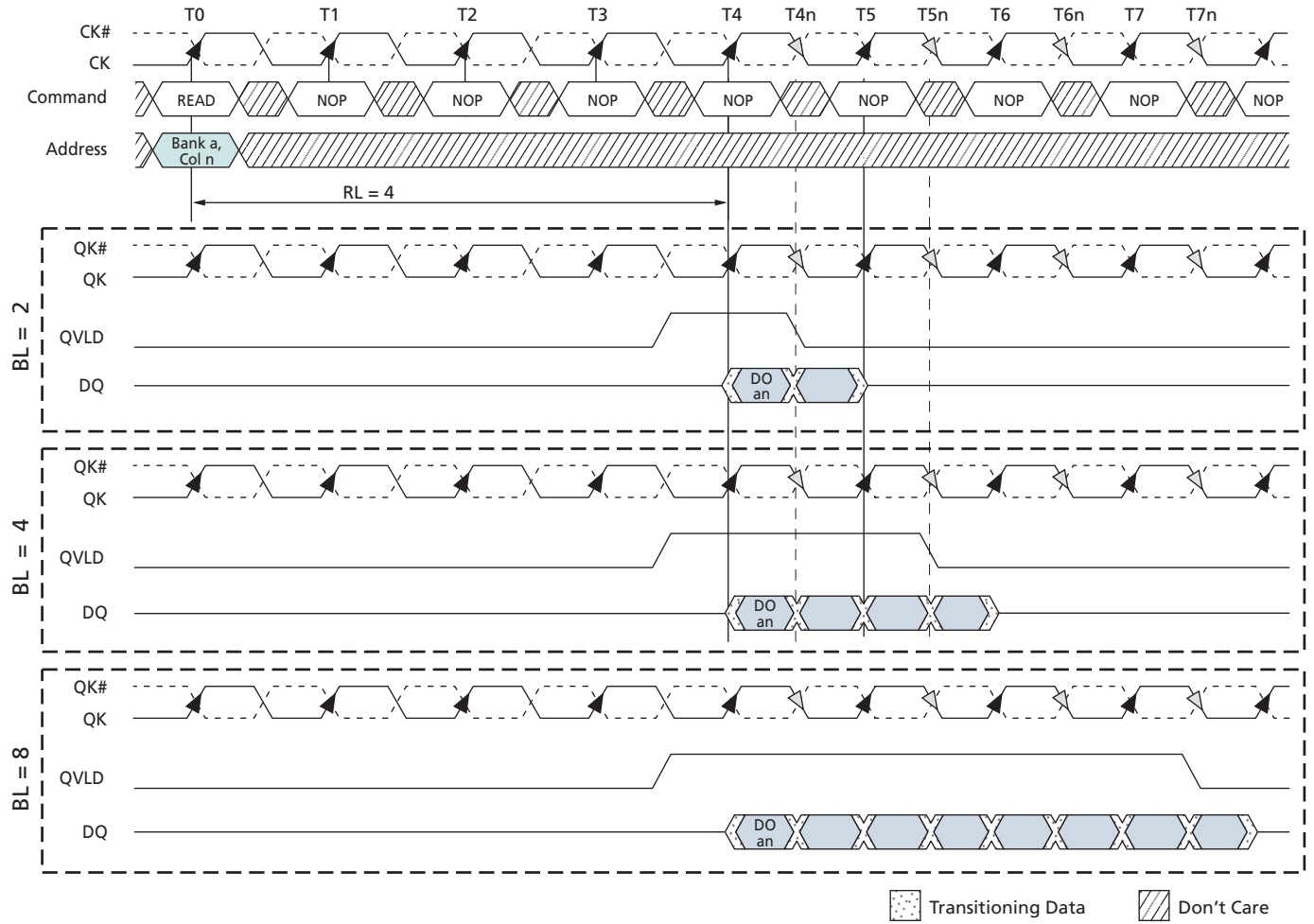

Note: 1. DO an = data-out from bank a and address an.

Mode Register 2 (MR2)

Figure 35: MR2 Definition for Non-Multiplexed Address Mode

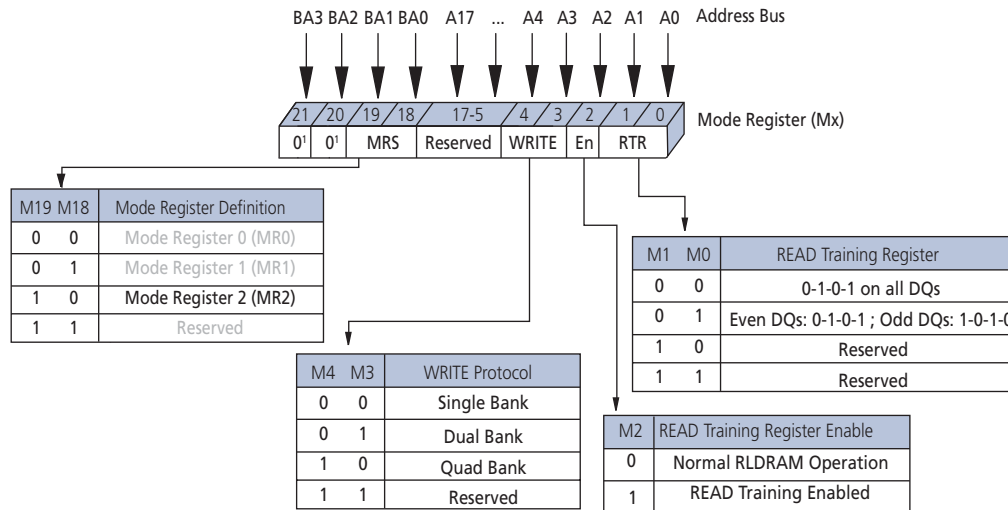

Note: 1. BA2, BA3, and all address balls corresponding to reserved bits must be held LOW during the MRS command.

READ Training Register (RTR)

The READ training register (RTR) is controlled through MR2[2:0]. It is used to output a predefined bit sequence on the output balls to aid in system timing calibration. MR2[2] is the master bit that enables or disables access to the READ training register, and MR2[1:0] determine which predefined pattern for system calibration is selected. If MR2[2] is set to 0, the RTR is disabled, and the DRAM operates in normal mode. When MR2[2] is set to 1, the DRAM no longer outputs normal read data, but a predefined pattern that is defined by MR2[1:0].

Prior to enabling the RTR, all banks must be in the idle state (^tRC met). When the RTR is enabled, all subsequent READ commands will output four bits of a predefined sequence from the RTR on all DQs. The READ latency during RTR is defined with the Data Latency bits in MR0. To loop on the predefined pattern when the RTR is enabled, successive READ commands must be issued and satisfy ^tRTRS. Address balls A[19:0] are considered "Don't Care" during RTR READ commands. Bank address bits BA[3:0] must access Bank 0 with each RTR READ command. ^tRC does not need to be met in between RTR READ commands to Bank 0. When the RTR is enabled, only READ commands are allowed. When the last RTR READ burst has completed and ^tRTRE has been satisfied, an MRS command can be issued to exit the RTR. Standard RLD RAM 3 operation may then start after ^tMRSC has been met. The RESET function is supported when the RTR is enabled.

If MR2[1:0] is set to 00 a 0-1-0-1 pattern will be output on all DQs with each RTR READ command. If MR2[1:0] is set to 01, a 0-1-0-1 pattern will output on all even DQs and the opposite pattern, a 1-0-1-0, will output on all odd DQs with each RTR READ command. **Note:** Enabling RTR may corrupt previously written data.

Figure 36: READ Training Function - Back-to-Back Readout

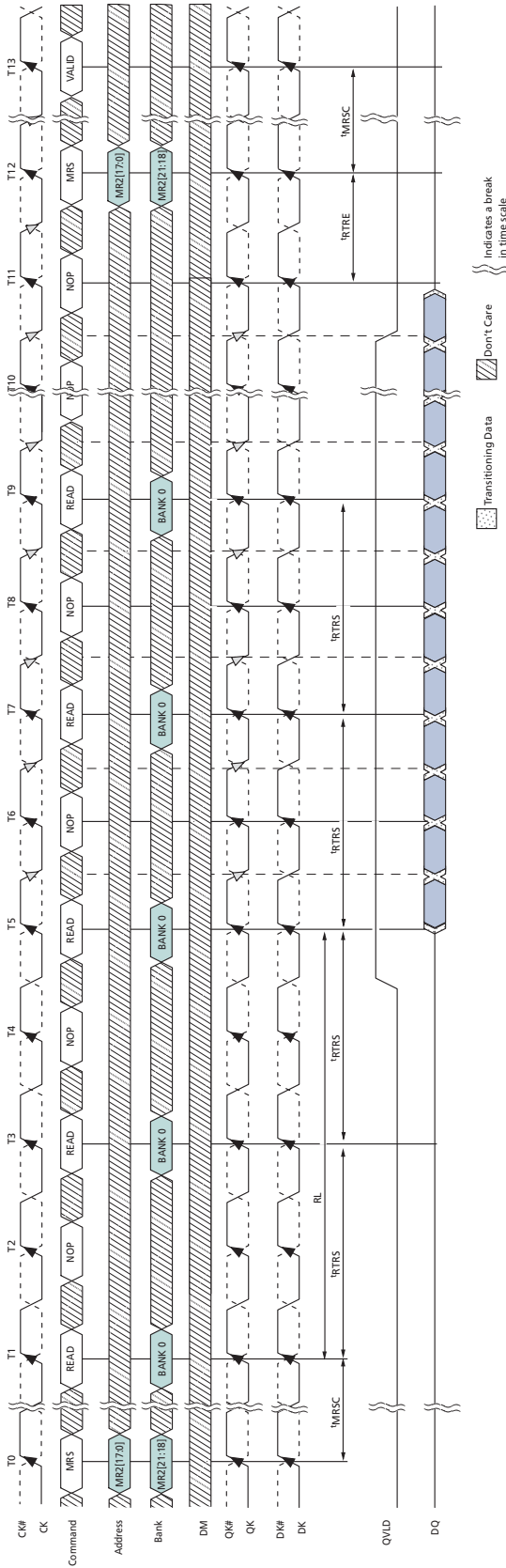

Note: 1. RL = READ latency defined with data latency MR0 setting.

WRITE Protocol

Single or multibank WRITE operation is programmed with bits MR2[4:3]. The purpose of multibank WRITE operation is to reduce the effective t_{RC} during READ commands. When dual- or quad-bank WRITE protocol is selected, identical data is written to two or four banks, respectively. With the same data stored in multiple banks on the RLD RAM, the memory controller can select the appropriate bank to READ the data from and minimize t_{RC} delay. Detailed information on the multibank WRITE protocol can be found in Multibank WRITE (page 76).

WRITE Command

Write accesses are initiated with a WRITE command. The address needs to be provided concurrent with the WRITE command.

During WRITE commands, data will be registered at both edges of DK, according to the programmed burst length (BL). The RLD RAM operates with a WRITE latency (WL) determined by the data latency bits within MR0. The first valid data is registered at the first rising DK edge WL cycles after the WRITE command.

Any WRITE burst may be followed by a subsequent READ command (assuming t_{RC} is met). Depending on the amount of input timing skew, an additional NOP command might be necessary between WRITE and READ commands to avoid external data bus contention (see Figure 44 (page 84)).

Setup and hold times for incoming DQ relative to the DK edges are specified as t_{DS} and t_{DH} . The input data is masked if the corresponding DM signal is HIGH.

Figure 37: WRITE Command

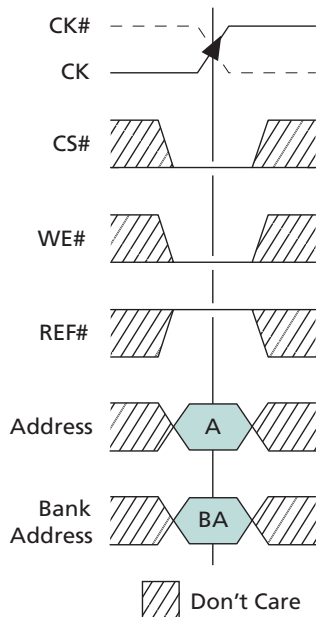



Multibank WRITE

All the information provided above in the WRITE section is applicable to a multibank WRITE operation as well. Either two or four banks can be simultaneously written to when the appropriate MR2[4:3] mode register bits are selected.

If a dual-bank WRITE has been selected through the mode register, both banks x and $x+8$ will be written to simultaneously with identical data provided during the WRITE command. For example, when a dual-bank WRITE has been loaded and the bank address for Bank 1 has been provided during the WRITE command, Bank 9 will also be written to at the same time. When a dual-bank WRITE command is issued, only bank address bits BA[2:0] are valid and BA3 is considered a “Don’t Care.”

The same methodology is used if the quad-bank WRITE has been selected through the mode register. Under these conditions, when a WRITE command is issued to Bank x , the data provided on the DQs will be issued to banks x , $x+4$, $x+8$, and $x+12$. When a quad-bank WRITE command is issued, only bank address bits BA[1:0] are valid and BA[3:2] are considered “Don’t Care.”

The timing parameter t_{SAW} must be adhered to when operating with multibank WRITE commands. This parameter limits the number of active banks at 16 within an 8ns window. The t_{MMD} specification must also be followed if the quad-bank WRITE is being used. This specification requires two clock cycles between any bank command (READ, WRITE, or AREF) to a quad-bank WRITE or a quad-bank WRITE to any bank command. The data bus efficiency is not compromised if BL4 or BL8 is being utilized.

READ Command

Read accesses are initiated with a READ command (see the figure below). Addresses are provided with the READ command.

During READ bursts, the memory device drives the read data so it is edge-aligned with the QK signals. After a programmable READ latency, data is available at the outputs. One half clock cycle prior to valid data on the read bus, the data valid signal(s), QVLD, transitions from LOW to HIGH. QVLD is also edge-aligned with the QK signals.

The skew between QK and the crossing point of CK is specified as t_{CKQK} . t_{QKQx} is the skew between a QK pair and the last valid data edge generated at the DQ signals in the associated byte group, such as DQ[7:0] and QK0. t_{QKQx} is derived at each QK clock edge and is not cumulative over time. For the x36 device, the t_{QKQ02} and t_{QKQ13} specifications define the relationship between the DQs and QK signals within specific data word groupings. t_{QKQ02} defines the skew between QK0 and DQ[26:18] and between QK2 and DQ[8:0]. t_{QKQ13} defines the skew between QK1 and DQ[35:17] and between QK3 and DQ[17:9].

After completion of a burst, assuming no other commands have been initiated, output data (DQ) will go High-Z. The QVLD signal transitions LOW on the last bit of the READ burst. The QK clocks are free-running and will continue to cycle after the read burst is complete. Back-to-back READ commands are possible, producing a continuous flow of output data.

Any READ burst may be followed by a subsequent WRITE command. Some systems having long line lengths or severe skews may need an additional idle cycle inserted between READ and WRITE commands to prevent data bus contention.

Figure 38: READ Command

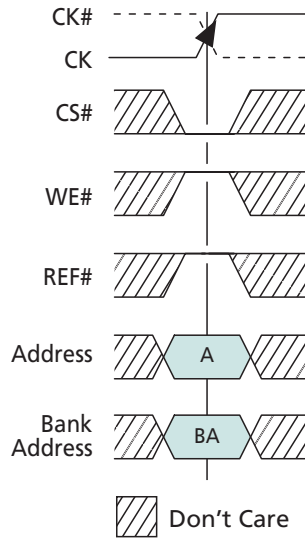

AUTO REFRESH Command

The RLD RAM 3 device uses two unique AUTO REFRESH (AREF) command protocols, bank address-controlled AREF and multibank AREF. The desired protocol is selected by setting MR1[8] LOW (for bank address-controlled AREF) or HIGH (for multibank AREF) during an MRS command. Bank address-controlled AREF is identical to the method used in RLD RAM2 devices, whereby banks are refreshed independently. The value on bank addresses BA[3:0], issued concurrently with the AREF command, define which bank is to be refreshed. The array address is generated by an internal refresh counter, effectively making each address bit a "Don't Care" during the AREF command. The delay between the AREF command and a subsequent command to the same bank must be at least t_{RC} .

Figure 39: Bank Address-Controlled AUTO REFRESH Command

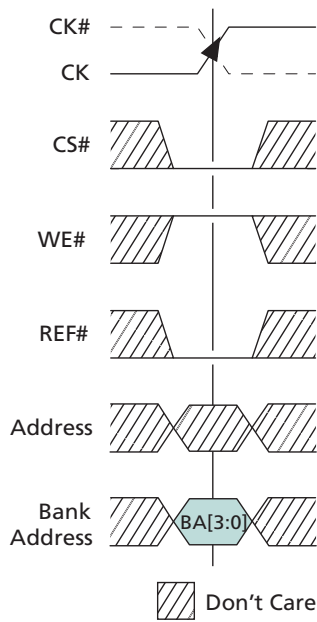

The multibank AREF protocol, enabled by setting bit MR1[8] HIGH during an MRS command, enables the simultaneous refresh of a row in up to four banks. In this method, address balls A[15:0] represent banks [15:0], respectively. The row addresses are generated by an internal refresh counter for each bank; therefore, the purpose of the address balls during an AREF command is only to identify the banks to be refreshed. The bank address balls BA[3:0] are considered "Don't Care" during a multibank AREF command.

A multibank AUTO REFRESH is performed for a given bank when its corresponding address ball is asserted HIGH during an AREF command. Any combination of up to four address balls can be asserted HIGH during the rising clock edge of an AREF command to simultaneously refresh a row in each corresponding bank. The delay between an AREF command and subsequent commands to the banks refreshed must be at least t_{RC} . Adherence to t_{SAW} must be followed when simultaneously refreshing multiple banks. If refreshing three or four banks with the multibank AREF command, t_{MMD} must be followed. This specification requires two clock cycles between any bank command (READ, WRITE, AREF) to the multibank AREF or the multibank AREF to any bank

command. Note that refreshing one or two banks with the multibank AREF command is not subject to the t_{MMD} specification.

The entire device must be refreshed every 64ms (t_{REF}). The RLD RAM device requires 128K cycles at an average periodic interval of 0.489 μ s MAX (64ms/[8K rows x 16 banks]).

Figure 40: Multibank AUTO REFRESH Command

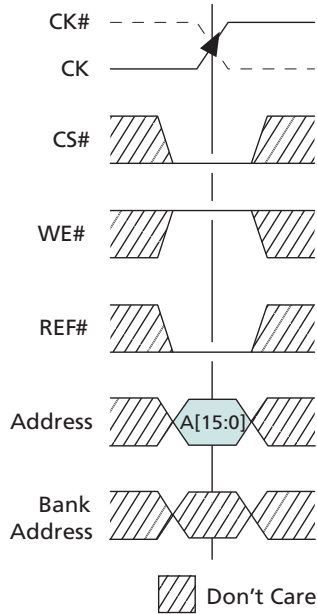



INITIALIZATION Operation

The RLD RAM 3 device must be powered up and initialized in a predefined manner. Operational procedures other than those specified may result in undefined operations or permanent damage to the device.

The following sequence is used for power-up:

1. Apply power (V_{EXT} , V_{DD} , V_{DDQ}). Apply V_{DD} and V_{EXT} before, or at the same time as, V_{DDQ} . V_{DD} must not exceed V_{EXT} during power supply ramp. V_{EXT} , V_{DD} , V_{DDQ} must all ramp to their respective minimum DC levels within 200ms.
2. Ensure that $RESET\#$ is below $0.2 \times V_{DDQ}$ during power ramp to ensure the outputs remain disabled (High-Z) and ODT is off (R_{TT} is also High-Z). DQs, and QK signals will remain High-Z until MR0 command. All other inputs may be undefined during the power ramp.
3. After the power is stable, $RESET\#$ must be LOW for at least 200 μ s to begin the initialization process.
4. After 100 or more stable input clock cycles with NOP commands, bring $RESET\#$ HIGH.
5. After $RESET\#$ goes HIGH, a stable clock must be applied in conjunction with NOP commands and all Address pins (A[19:0] & BA[3:0]) to be held low for 10,000 cycles.
6. Load desired settings into MR0.
7. MRSC after loading the MR0 settings, load operating parameters in MR1, including DLL Reset and Long ZQ Calibration.
8. After the DLL is reset and Long ZQ Calibration is enabled, the input clock must be stable for 512 clock cycles while NOPs are issued.
9. Load desired settings into MR2. If using the RTR, follow the procedure outlined in the READ Training Function – Back-to-Back Readout figure prior to entering normal operation.
10. The RLD RAM 3 is ready for normal operation.

Figure 41: Power-Up/Initialization Sequence

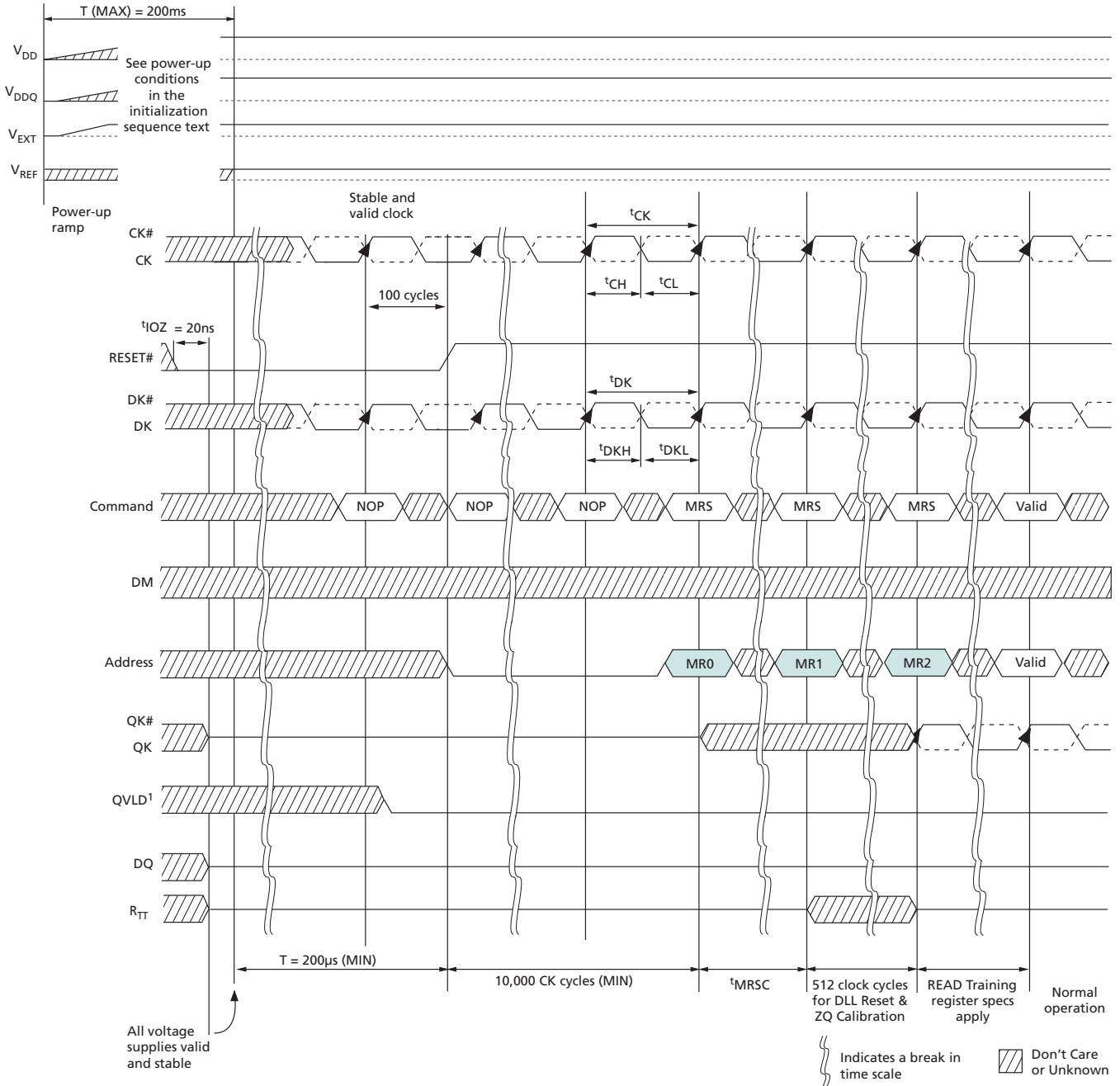

- Notes: 1. QVLD output drive status during power-up and initialization:
- QVLD remains High-Z until 20ns after power supplies are stable and TCK or CK have cycled 4 times.
 - QVLD will then drive LOW with 40Ω or lower until the output drive value selected in MR1 is enabled.



- c. ^tMRSC after loading the MR1 settings, QVLD output drive strength will be at the value selected or lower until ZQ calibration is complete.
 - d. QVLD will meet the output drive strength specifications upon completion of the ZQ calibration timing.
2. After MR2 has been issued, Rtt is either High-Z or enabled to the ODT value selected in MR1.

WRITE Operation

Figure 42: WRITE Burst

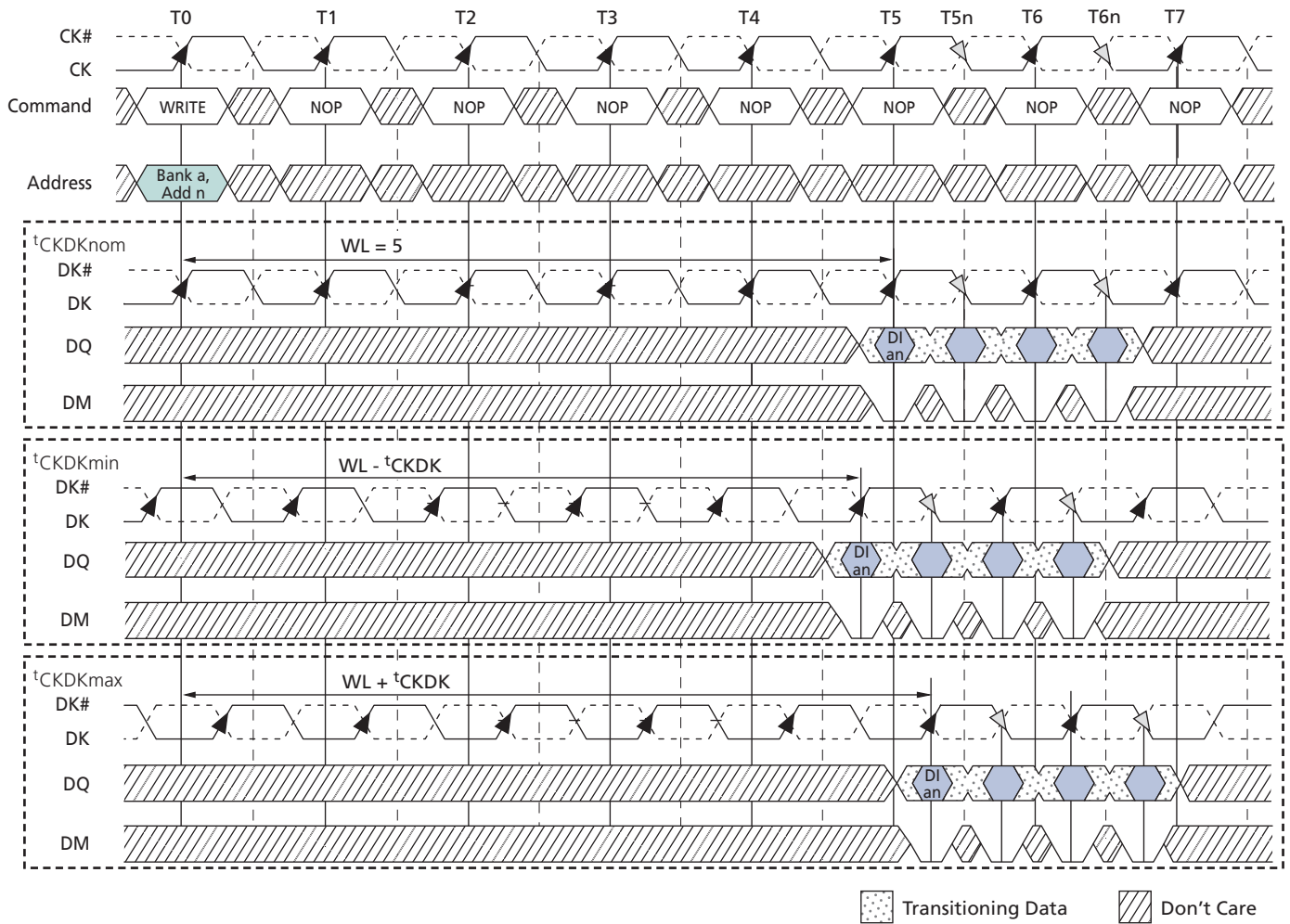

Note: 1. DI an = data-in for bank a and address n.

Figure 43: Consecutive WRITE Bursts

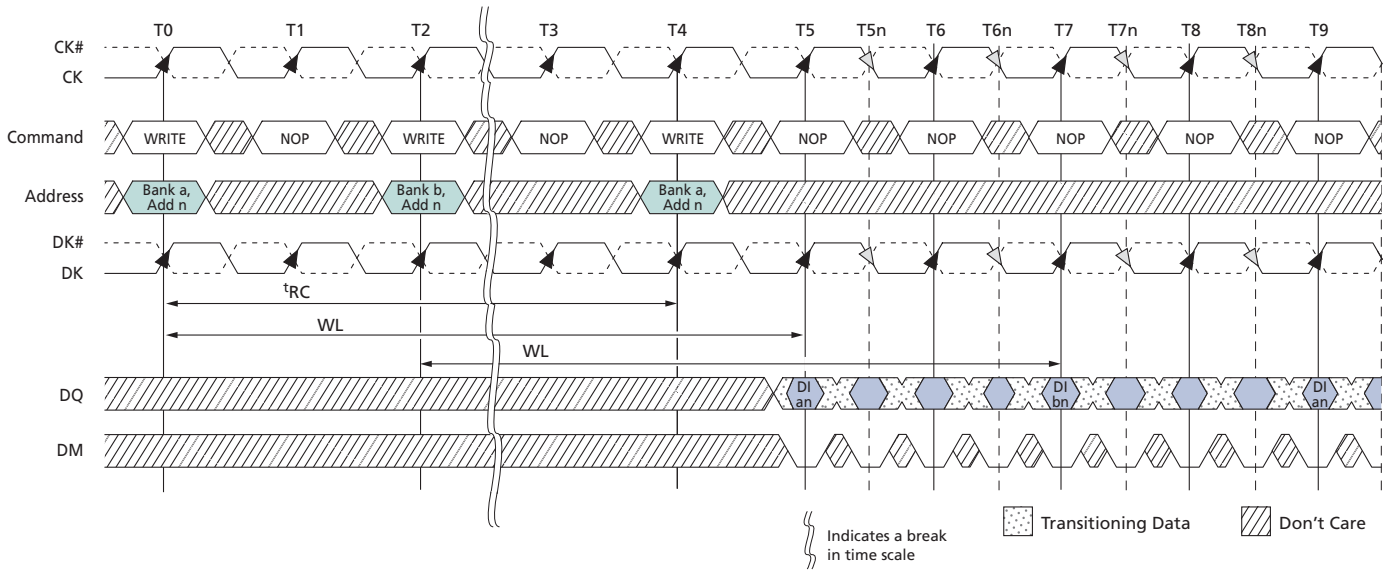

Note: 1. DI an (or bn or cn) = data-in for bank a (or b or c) and address n.

Figure 44: WRITE-to-READ

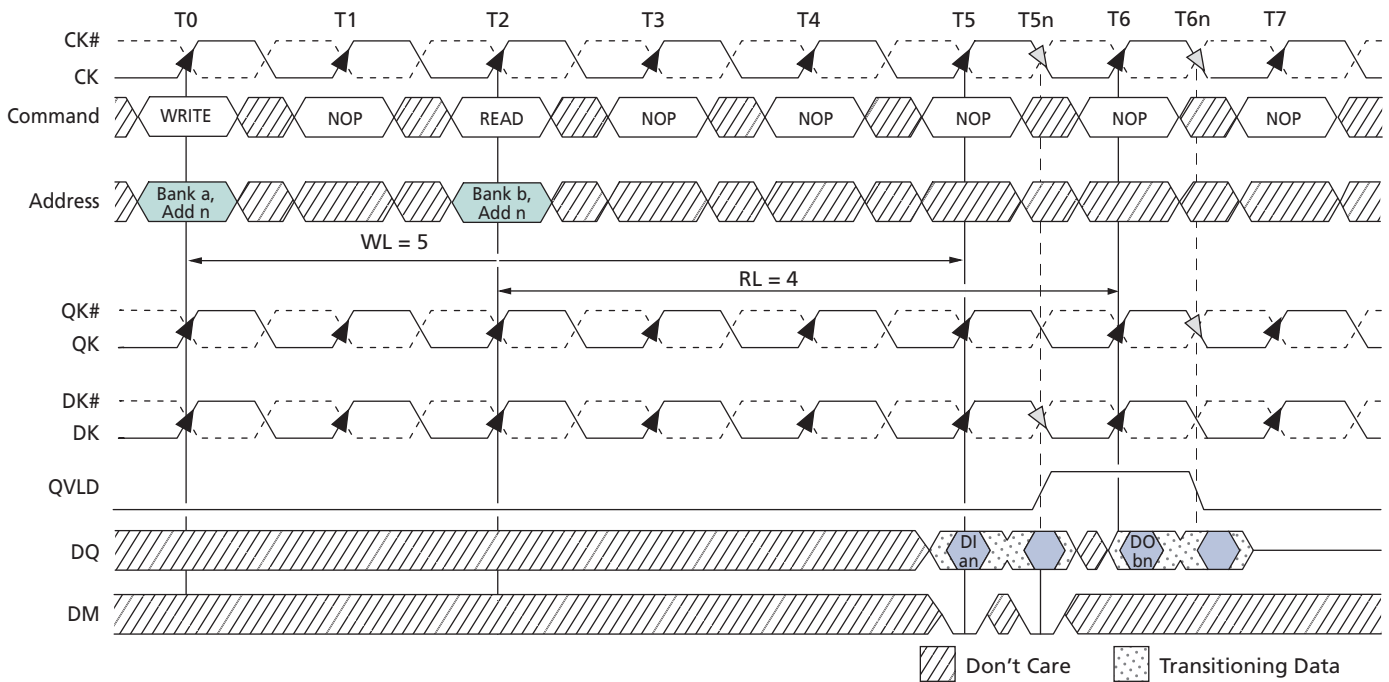

Notes: 1. DI an = data-in for bank a and address n.
2. DO bn = data-out from bank b and address n.

Figure 45: WRITE - DM Operation

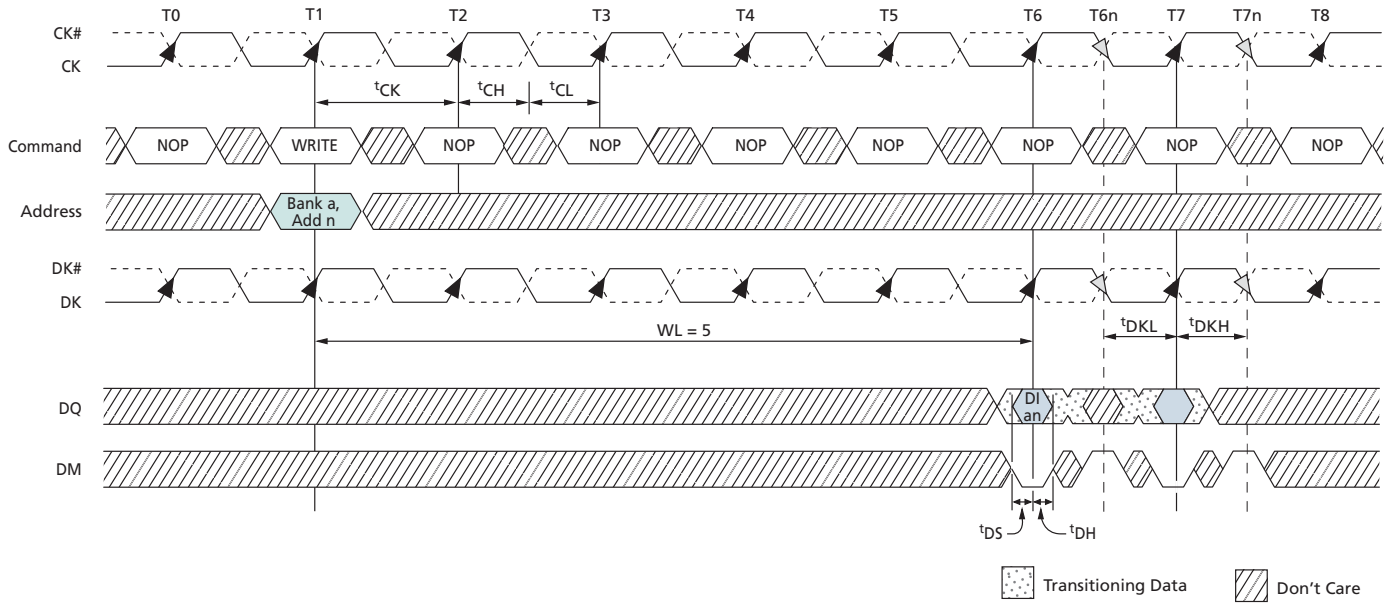

Note: 1. DI an = data-in for bank a and address n.

Figure 46: Consecutive Quad Bank WRITE Bursts

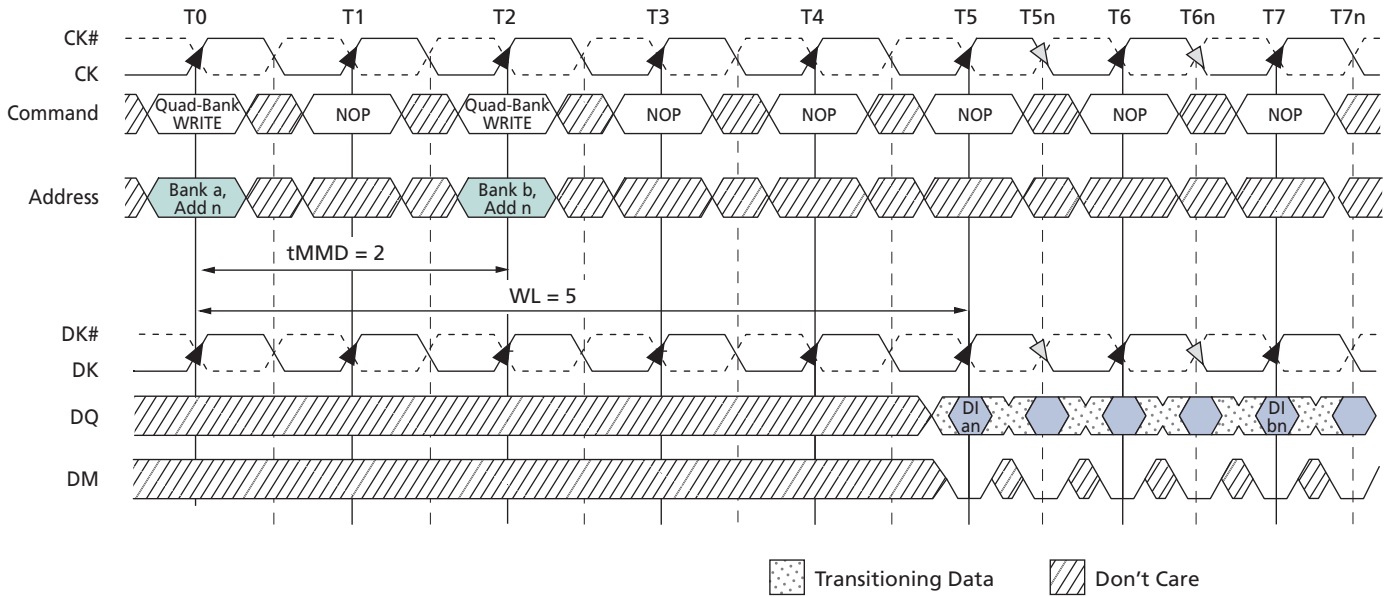

- Notes: 1. DI *an* = data-in for bank *a*, *a*+4, *a*+8, and *a*+12 and address *n*.
 2. DI *bn* = data-in for bank *b*, *b*+4, *b*+8, and *b*+12 and address *n*.

Figure 47: Interleaved READ and Quad Bank WRITE Bursts

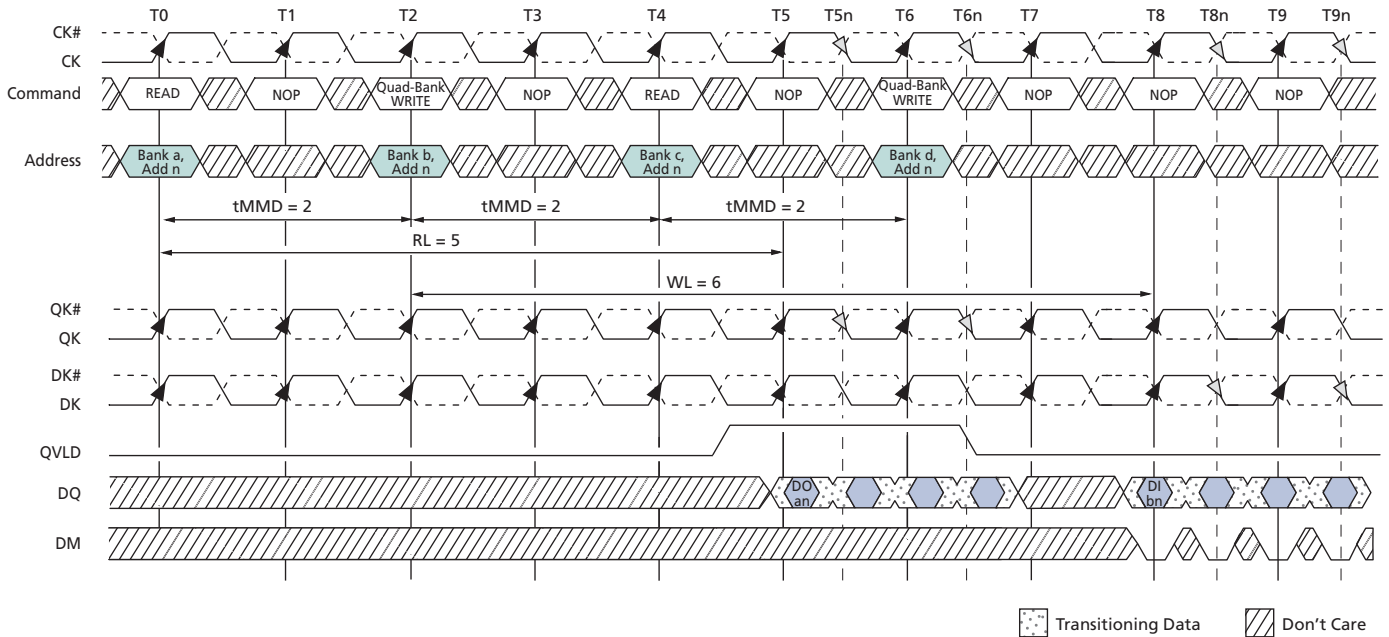

- Notes: 1. DO *an* = data-out for bank *a* and address *n*.
 2. DI *bn* = data-in for bank *b*, *b*+4, *b*+8, and *b*+12 and address *n*.

READ Operation

Figure 48: Basic READ Burst

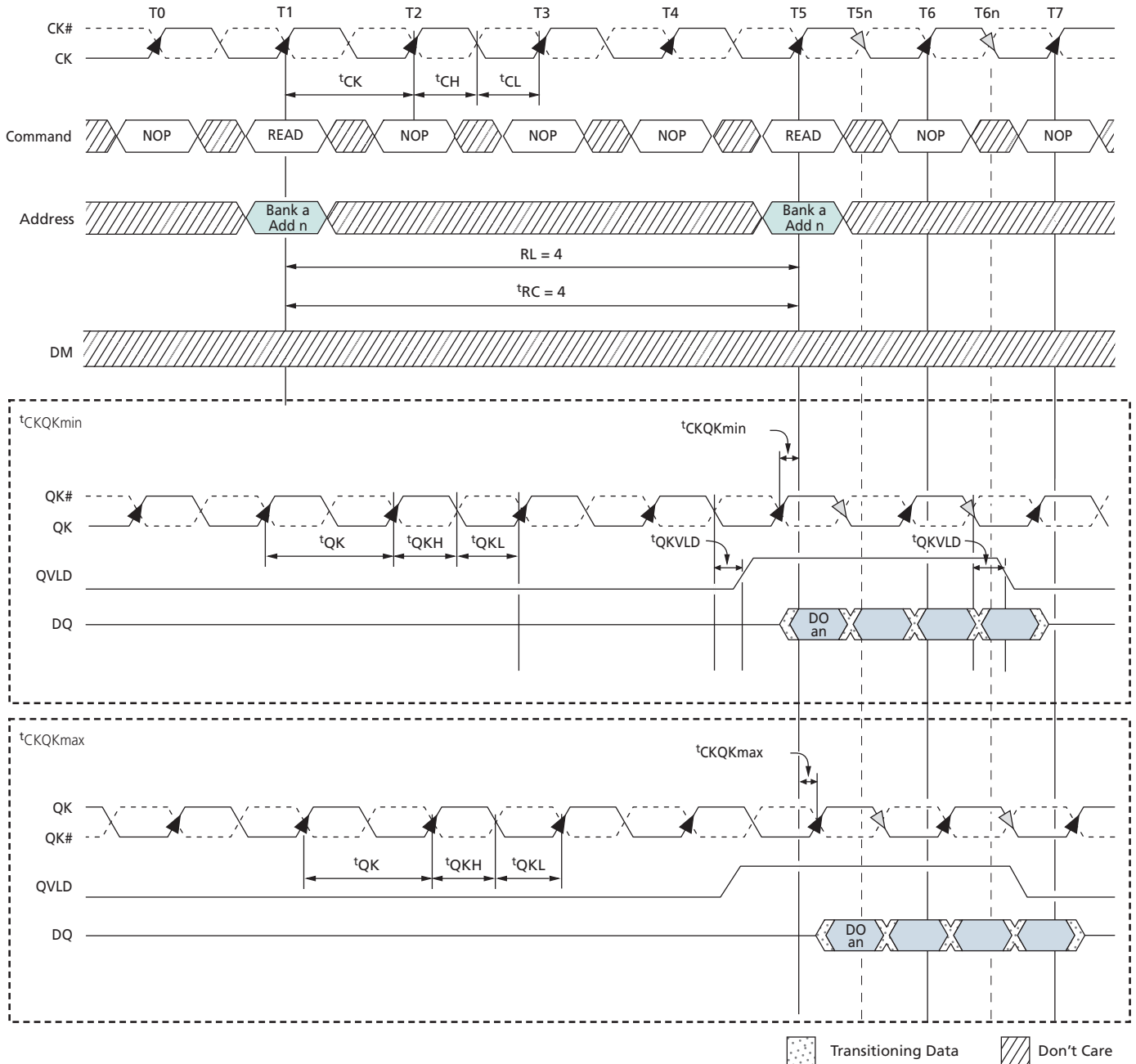

Note: 1. DO an = data-out from bank a and address an.

Figure 49: Consecutive READ Bursts (BL = 2)

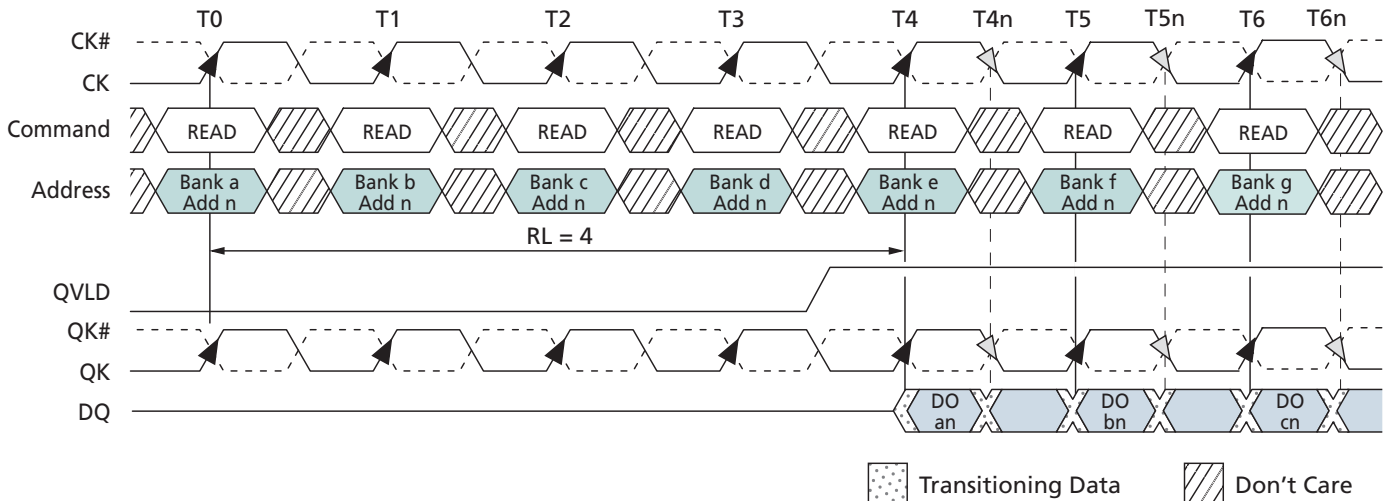

Note: 1. DO an (or bn, cn) = data-out from bank a (or bank b, c) and address n.

Figure 50: Consecutive READ Bursts (BL = 4)

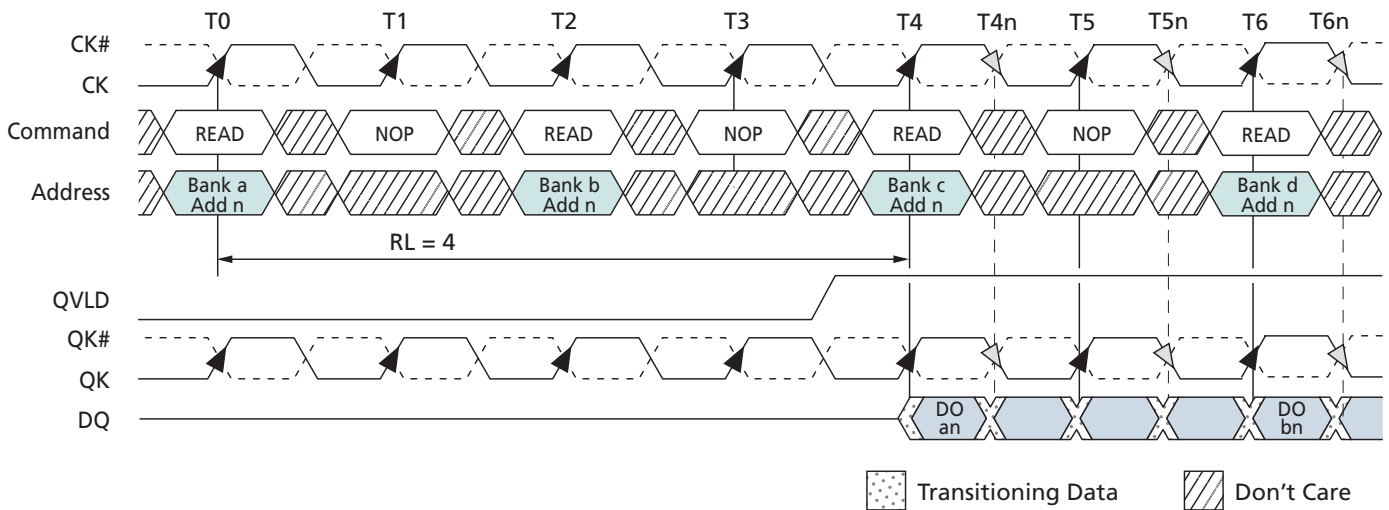

Note: 1. DO an (or bn) = data-out from bank a (or bank b) and address n.

Figure 51: READ-to-WRITE (BL = 2)

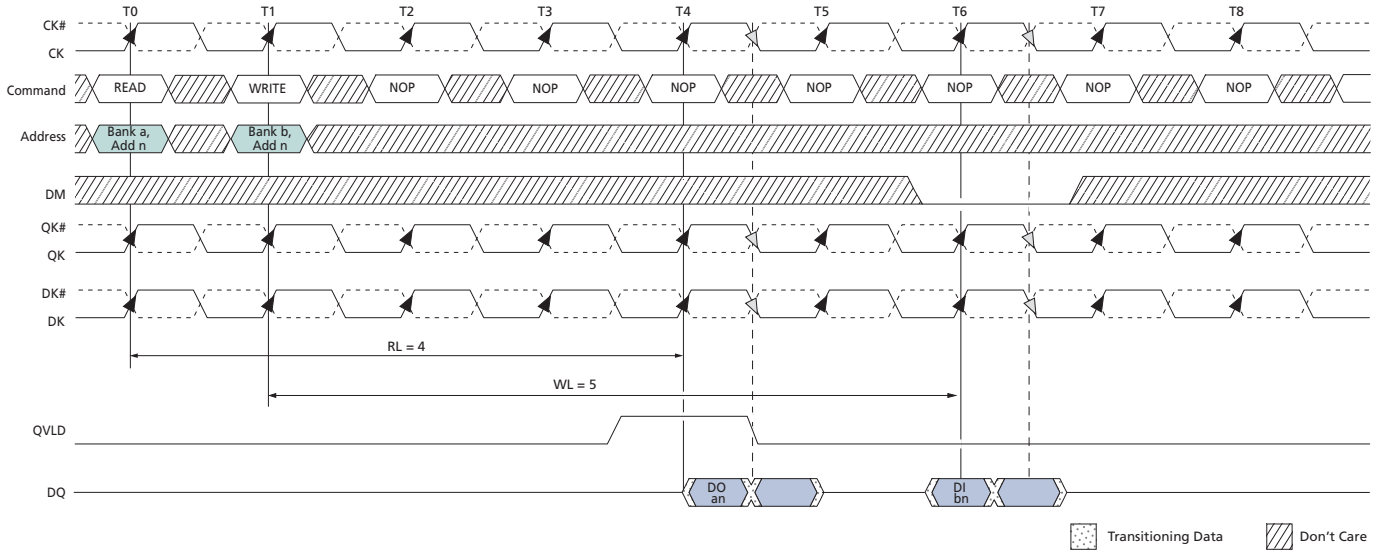

- Notes: 1. DO *an* = data-out from bank *a* and address *n*.
2. DI *bn* = data-in for bank *b* and address *n*.

Figure 52: Read Data Valid Window

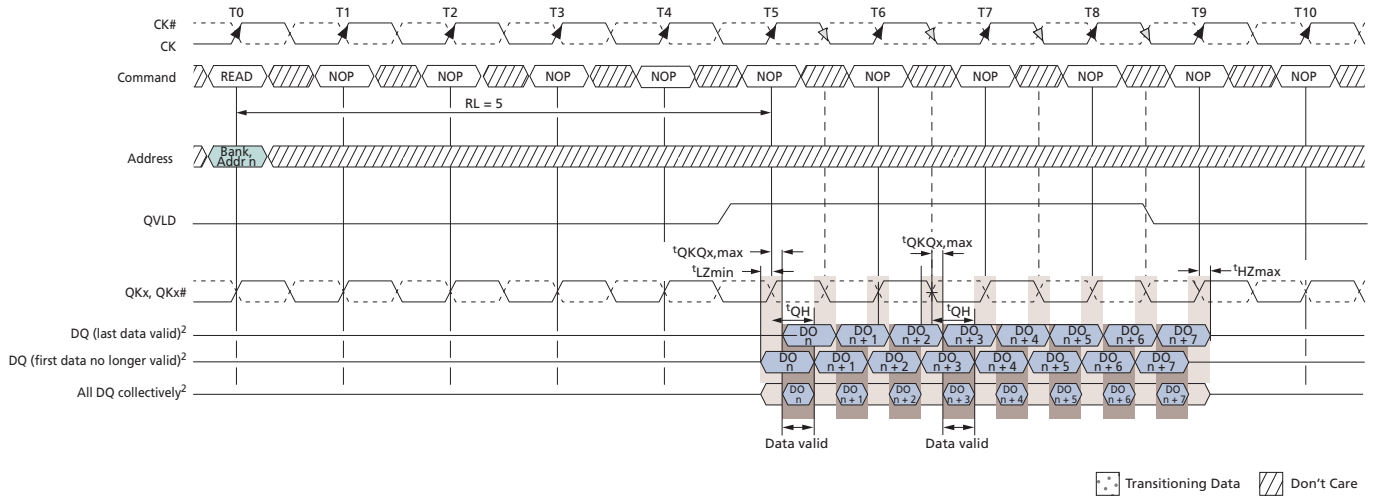

- Notes: 1. DO *n* = data-out from bank *a* and address *n*.
2. Represents DQs associated with a specific QK, QK# pair.
3. Output timings are referenced to $V_{DDQ}/2$ and DLL on and locked.
4. t_{QKQx} defines the skew between the QK0, QK0# pair to its respective DQs. t_{QKQx} does not define the skew between QK and CK.
5. Early data transitions may not always happen at the same DQ. Data transitions of a DQ can vary (either early or late) within a burst.

AUTO REFRESH Operation

Figure 53: Bank Address-Controlled AUTO REFRESH Cycle

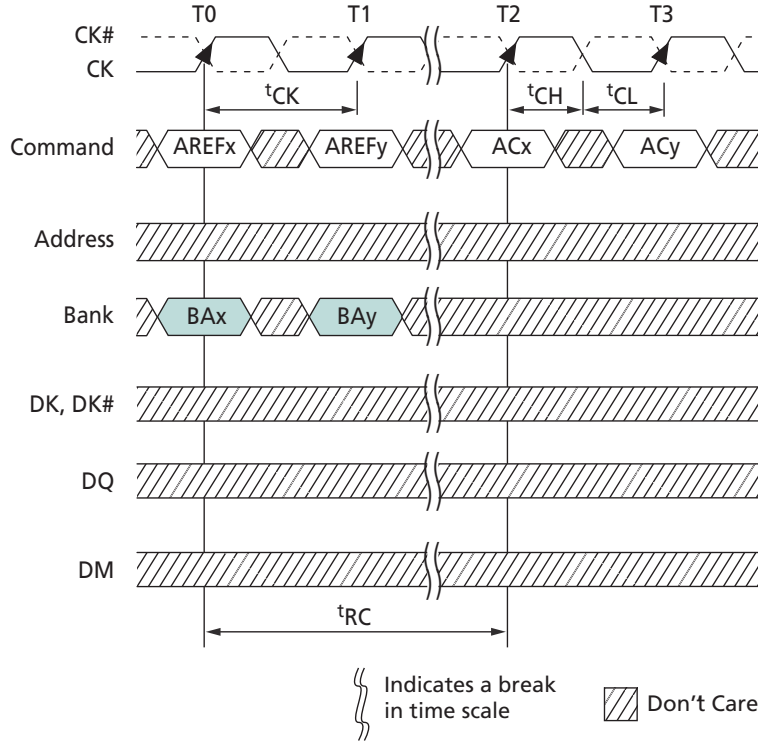

- Notes:
1. AREFx (or AREFy)= AUTO REFRESH command to bank x (or bank y).
 2. ACx = any command to bank x; ACy = any command to bank y.
 3. BAx = bank address to bank x; BAy = bank address to bank y.

Figure 54: Multibank AUTO REFRESH Cycle

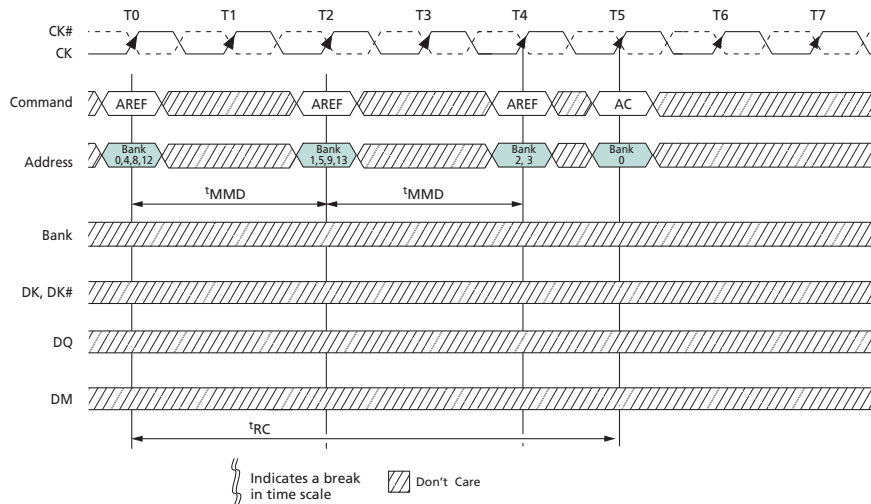
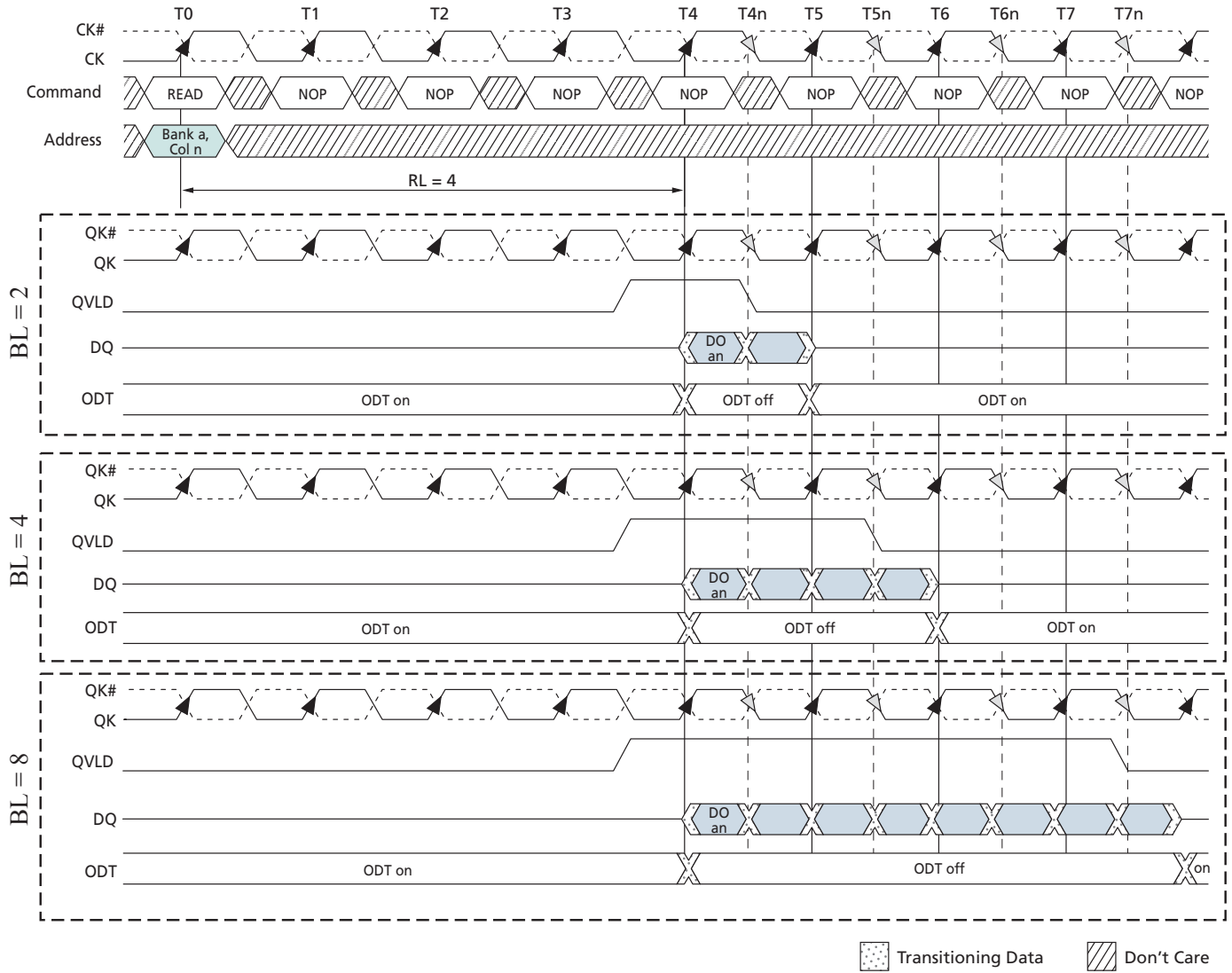
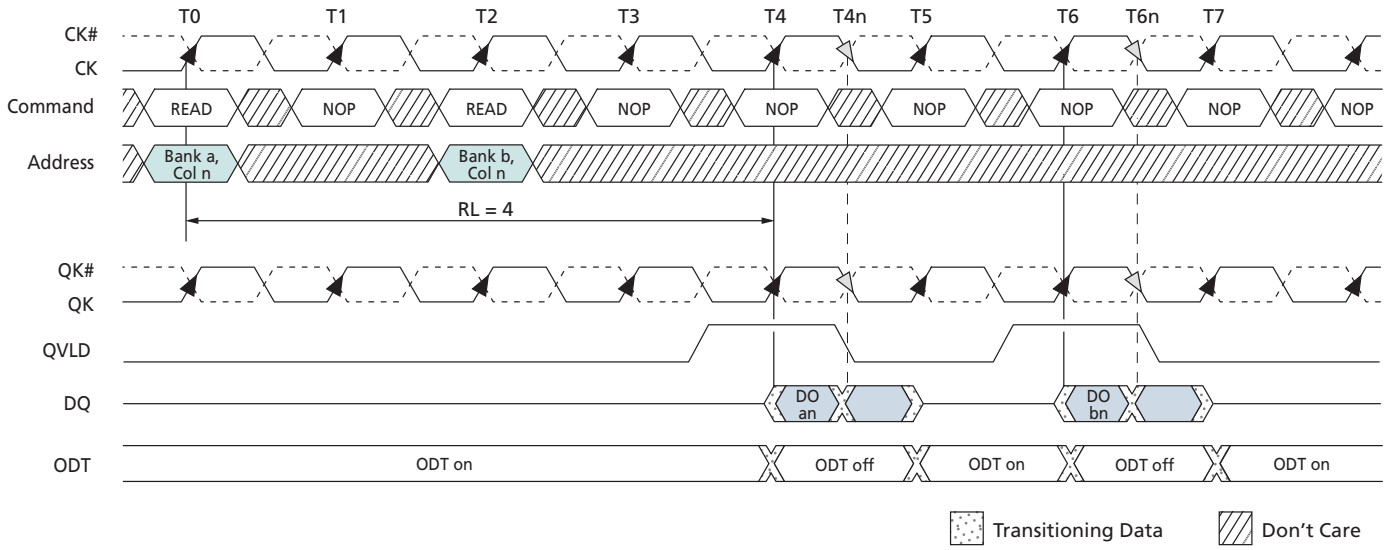

Figure 55: READ Burst with ODT



Note: 1. DO an = data out from bank a and address n.

Figure 56: READ-NOP-READ with ODT



Note: 1. DO an (or bn) = data-out from bank a (or bank b) and address n.

Multiplexed Address Mode

Figure 57: Command Description in Multiplexed Address Mode

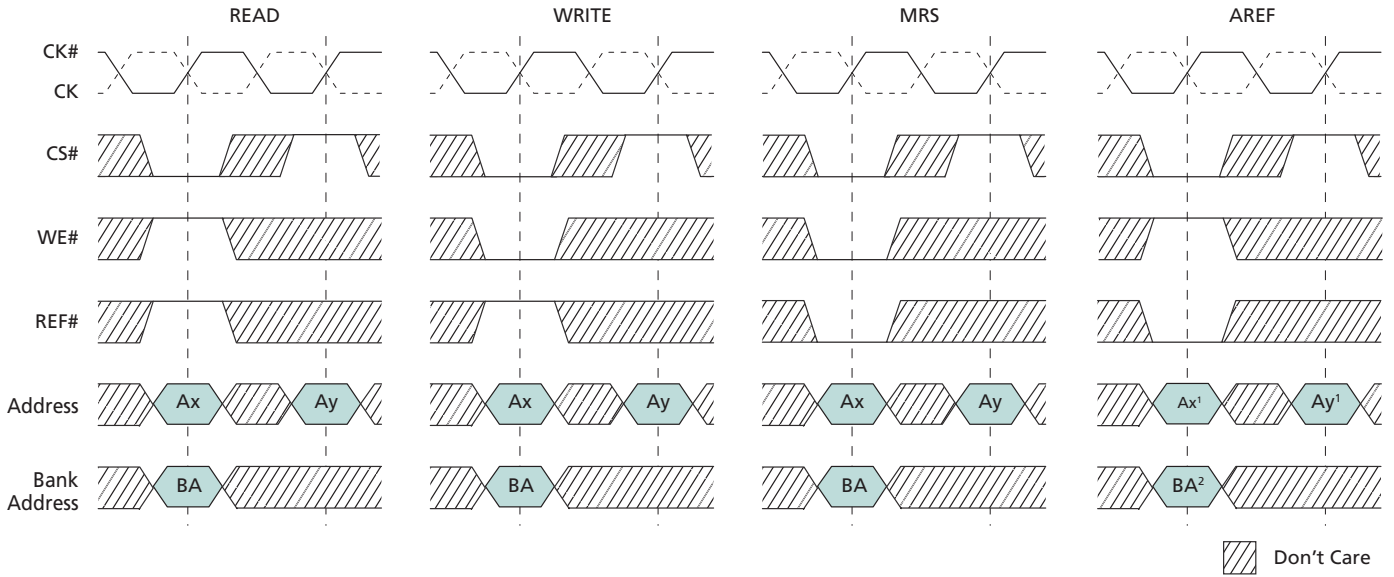

- Notes:
1. Addresses valid only during a multibank AUTO REFRESH command.
 2. Bank addresses valid only during a bank address-controlled AUTO REFRESH command.
 3. The minimum setup and hold times of the two address parts are defined as t_{IS} and t_{IH} .

Figure 58: Power-Up/Initialization Sequence in Multiplexed Address Mode

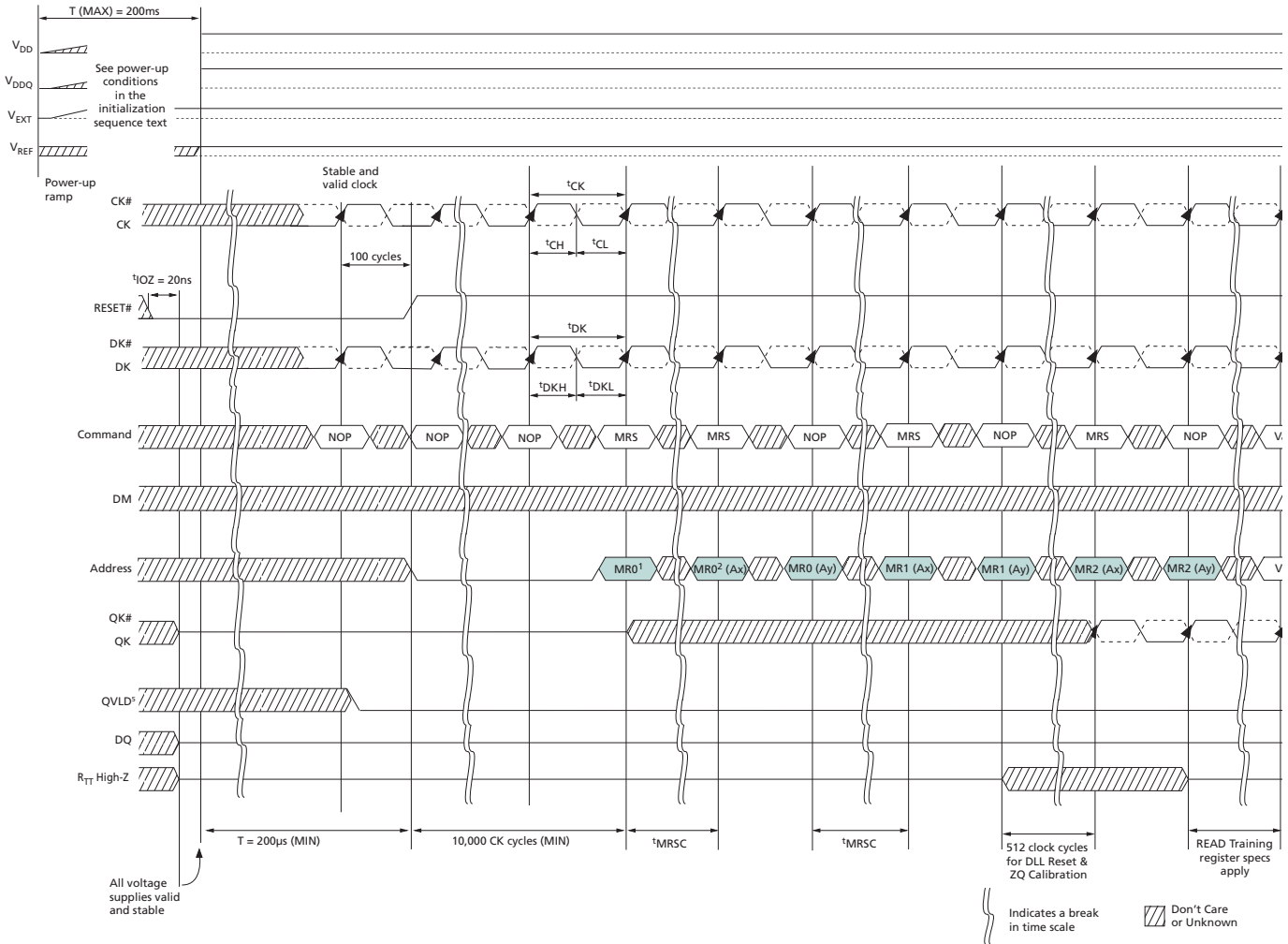

- Notes:
1. Set address bit MR0[9] HIGH. This enables the device to enter multiplexed address mode when in non-multiplexed mode operation. Multiplexed address mode can also be entered at a later time by issuing an MRS command with MR0[9] HIGH. After address bit MR0[9] is set HIGH, t_{MRSC} must be satisfied before the two-cycle multiplexed mode MRS command is issued.
 2. Address MR0[9] must be set HIGH. This and the following step set the desired MR0 setting after the RLD RAM device is in multiplexed address mode.
 3. MR1 (Ax), MR1 (Ay), MR2 (Ax), and MR2 (Ay) represent MR1 and MR2 settings in multiplexed address mode.
 4. The above sequence must be followed in order to power up the RLD RAM device in the multiplexed address mode.
 5. See QVLD output drive strength status during power up and initialization in non-multiplexed initialization operation section.
 6. After MR2 has been issued, R_{TT} is either High-Z or enabled to the ODT value selected in MR1.

Figure 59: MR0 Definition for Multiplexed Address Mode

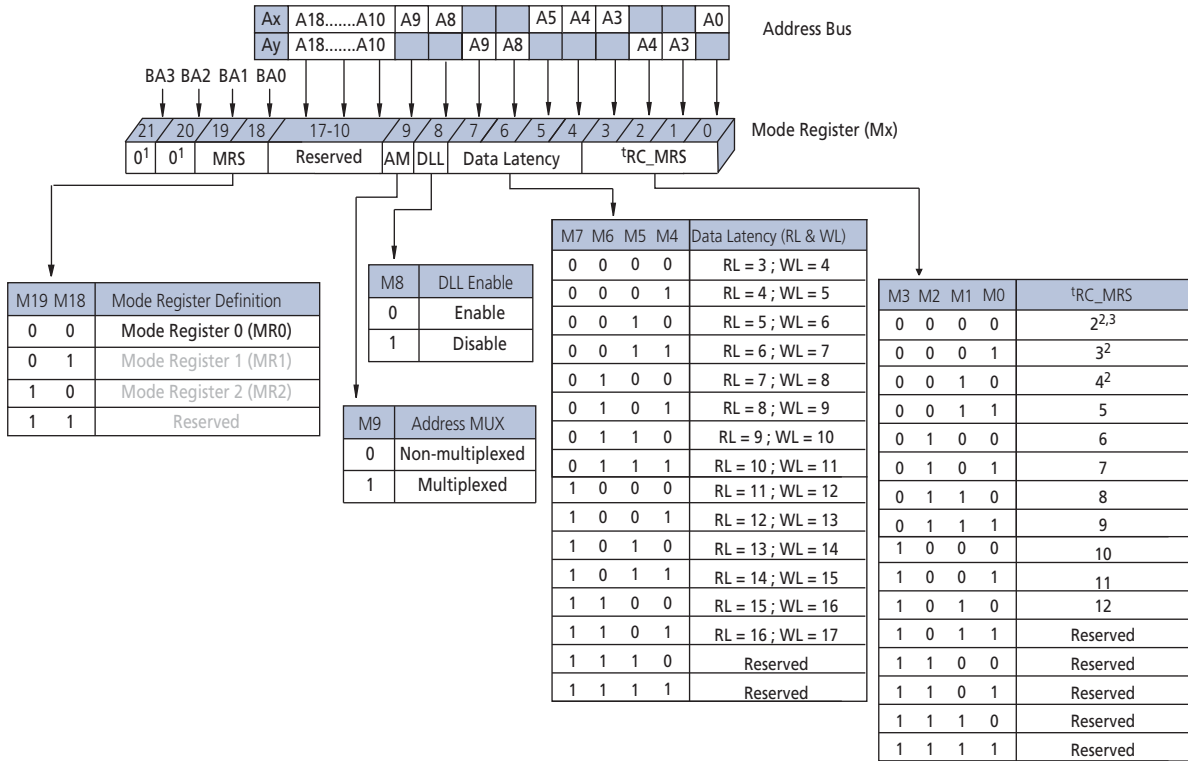

- Notes:
1. BA2, BA3, and all address balls corresponding to reserved bits must be held LOW during the MRS command.
 2. BL8 not allowed.
 3. BL4 not allowed.

Figure 60: MR1 Definition for Multiplexed Address Mode

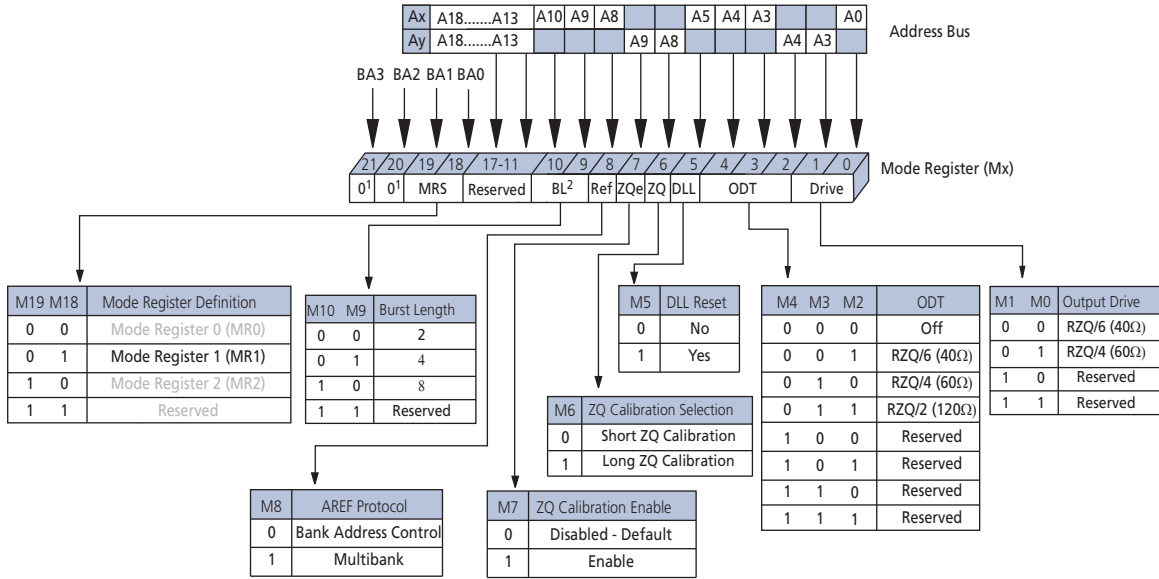

- Notes:
1. BA2, BA3, and all address balls corresponding to reserved bits must be held LOW during the MRS command.
 2. BL8 not available in x36.

Figure 61: MR2 Definition for Multiplexed Address Mode

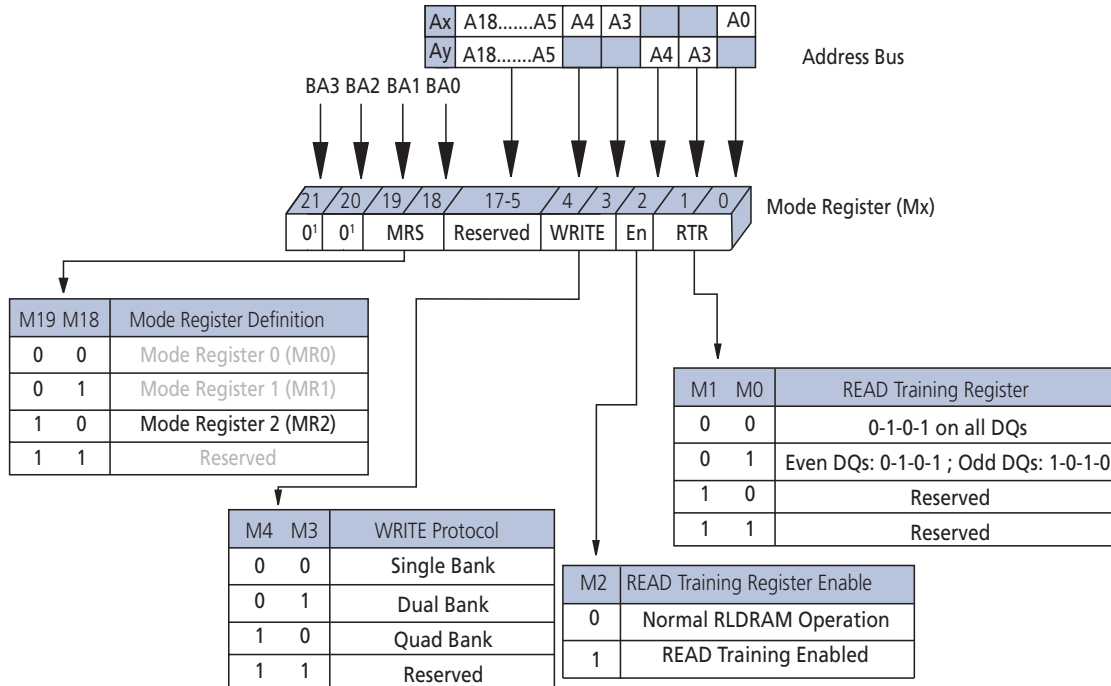

Note: 1. BA2, BA3, and all address balls corresponding to reserved bits must be held LOW during the MRS command.

Table 41: Address Mapping in Multiplexed Address Mode

| Data Width | Burst Length | Ball | Address | | | | | | | | | | |
|------------|--------------|------|---------|----|----|----|----|----|-----|-----|-----|-----|-----|
| | | | A0 | A3 | A4 | A5 | A8 | A9 | A10 | A13 | A14 | A17 | A18 |
| x36 | 2 | Ax | A0 | A3 | A4 | A5 | A8 | A9 | A10 | A13 | A14 | A17 | A18 |
| | | Ay | X | A1 | A2 | X | A6 | A7 | X | A11 | A12 | A16 | A15 |
| | 4 | Ax | A0 | A3 | A4 | A5 | A8 | A9 | A10 | A13 | A14 | A17 | X |
| | | Ay | X | A1 | A2 | X | A6 | A7 | X | A11 | A12 | A16 | A15 |
| x18 | 2 | Ax | A0 | A3 | A4 | A5 | A8 | A9 | A10 | A13 | A14 | A17 | A18 |
| | | Ay | X | A1 | A2 | X | A6 | A7 | A19 | A11 | A12 | A16 | A15 |
| | 4 | Ax | A0 | A3 | A4 | A5 | A8 | A9 | A10 | A13 | A14 | A17 | A18 |
| | | Ay | X | A1 | A2 | X | A6 | A7 | X | A11 | A12 | A16 | A15 |
| | 8 | Ax | A0 | A3 | A4 | A5 | A8 | A9 | A10 | A13 | A14 | A17 | X |
| | | Ay | X | A1 | A2 | X | A6 | A7 | X | A11 | A12 | A16 | A15 |

Note: 1. X = "Don't Care"

Data Latency in Multiplexed Address Mode

When in multiplexed address mode, data latency (READ and WRITE) begins when the A_y part of the address is issued with any READ or WRITE command. t_{RC} is measured from the clock edge in which the command and A_x part of the address is issued in both multiplexed and non-multiplexed address mode.

REFRESH Command in Multiplexed Address Mode

Similar to other commands when in multiplexed address mode, both modes of AREF (single and multibank) are executed on the rising clock edge, following the one on which the command is issued. However, when in bank address-controlled AREF, as only the bank address is required, the next command can be applied on the following clock. When using multibank AREF, the bank addresses are mapped across A_x and A_y so a subsequent command cannot be issued until two clock cycles later.

Figure 62: Bank Address-Controlled AUTO REFRESH Operation with Multiplexed Addressing

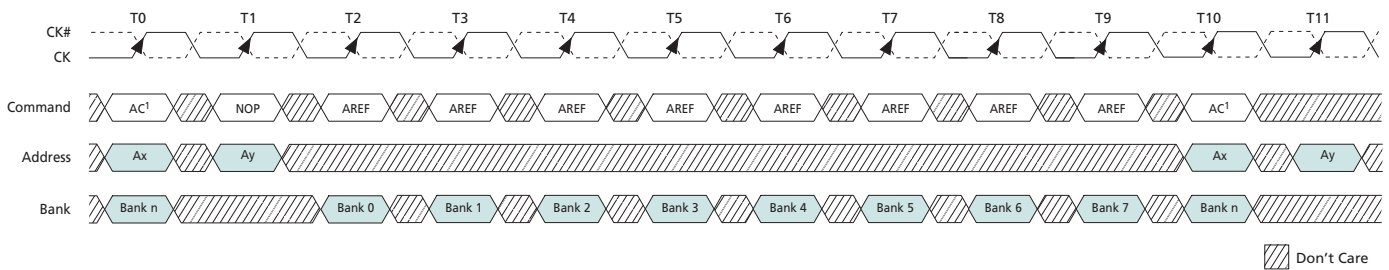

Note: 1. Any command subject to t_{RC} specification.

Figure 63: Multibank AUTO REFRESH Operation with Multiplexed Addressing

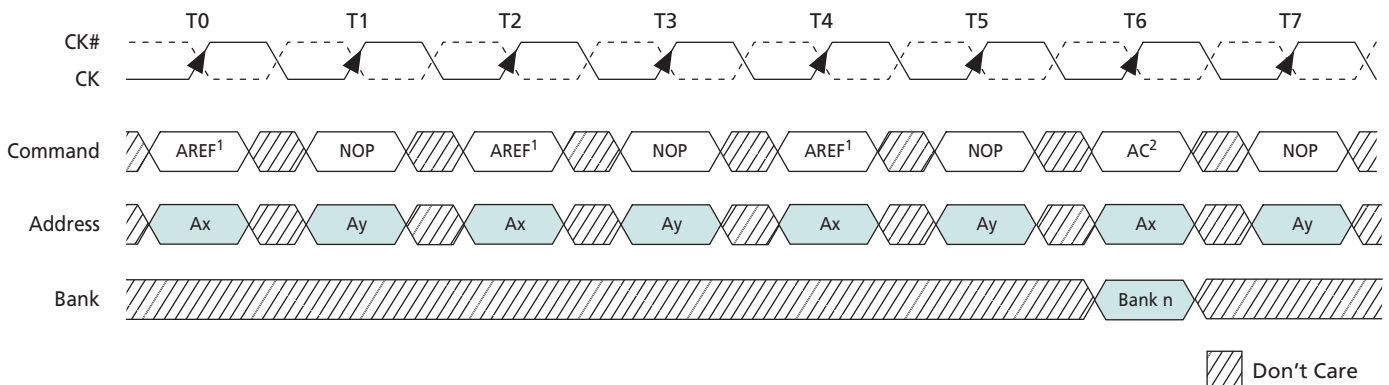

Notes: 1. Usage of multibank AREF subject to t_{SAW} and t_{MMD} specifications.
2. Any command subject to t_{RC} specification.

Figure 64: Consecutive WRITE Bursts with Multiplexed Addressing

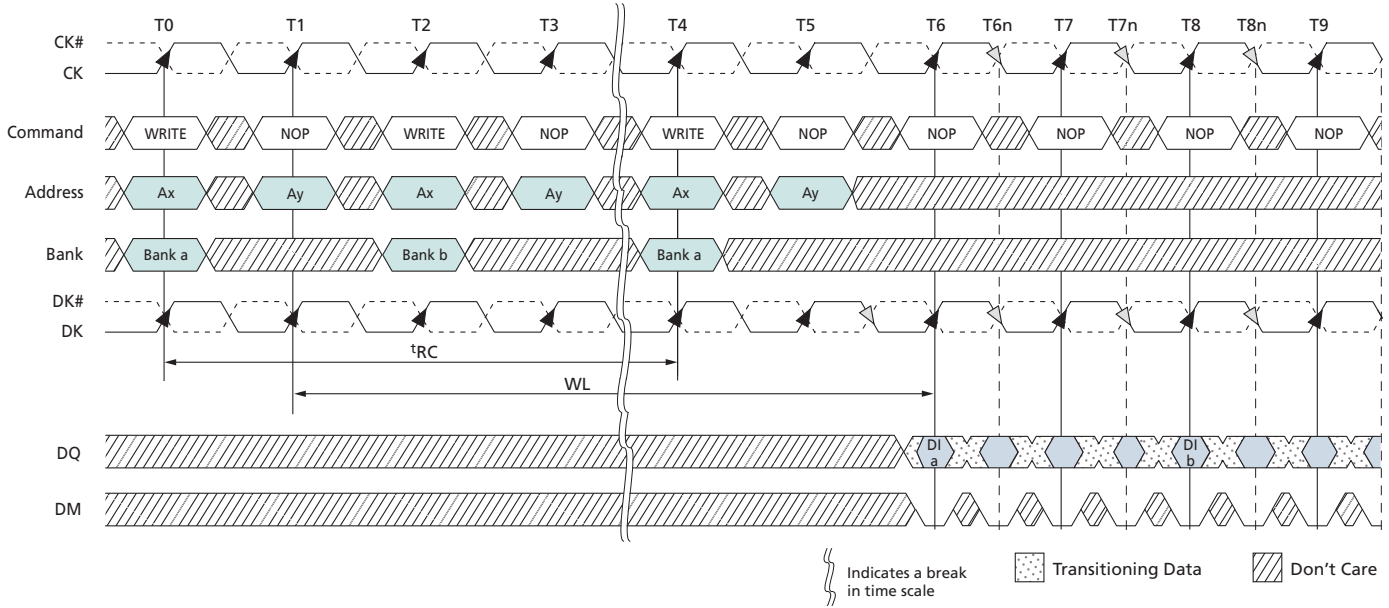

Note: 1. DI a = data-in for bank a; DI b = data-in for bank b.

Figure 65: WRITE-to-READ with Multiplexed Addressing

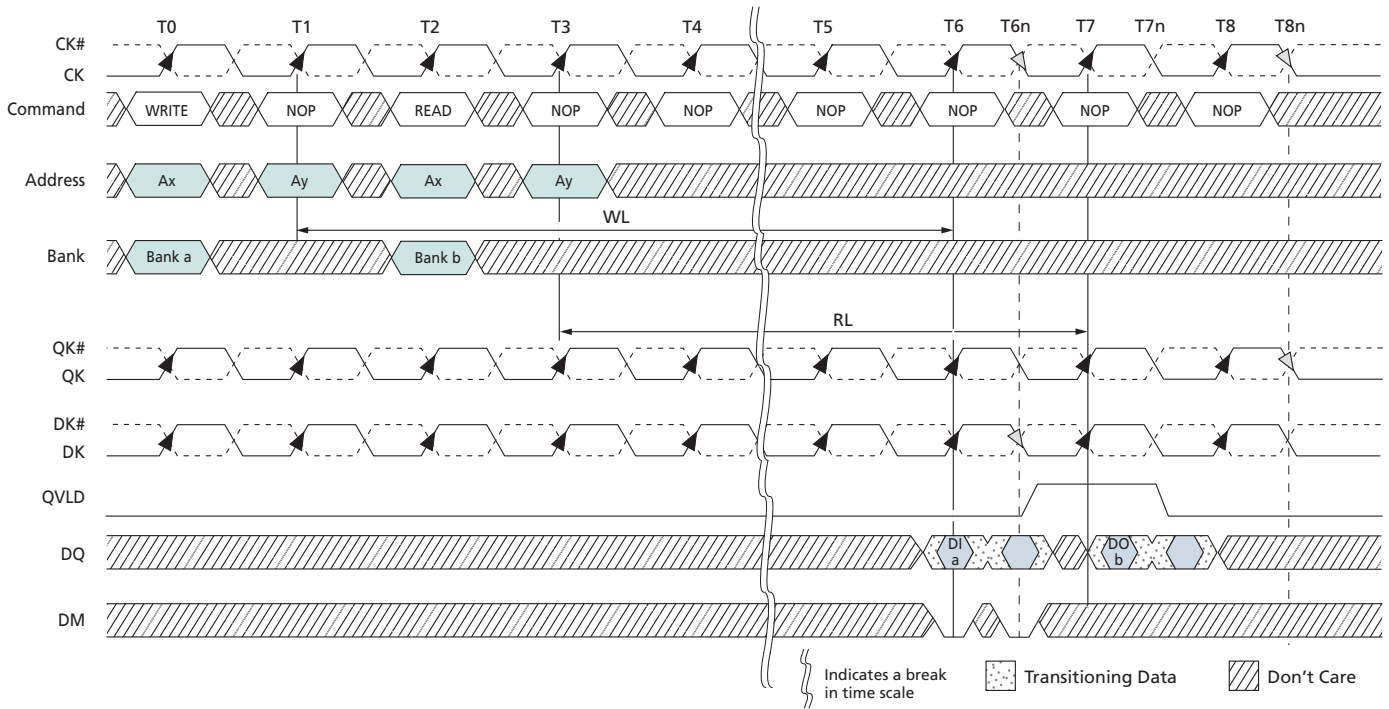

Note: 1. DI a = data-in for bank a; DI b = data-in for bank b.

Figure 66: Consecutive READ Bursts with Multiplexed Addressing

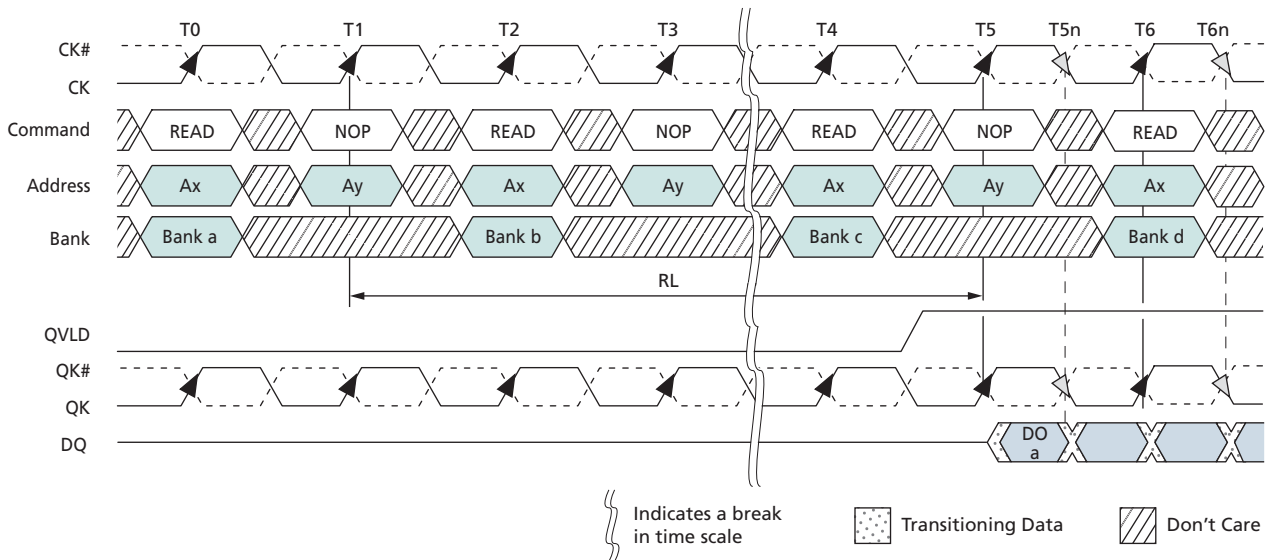

Note: 1. DO a = data-out for bank a.

Figure 67: READ-to-WRITE with Multiplexed Addressing

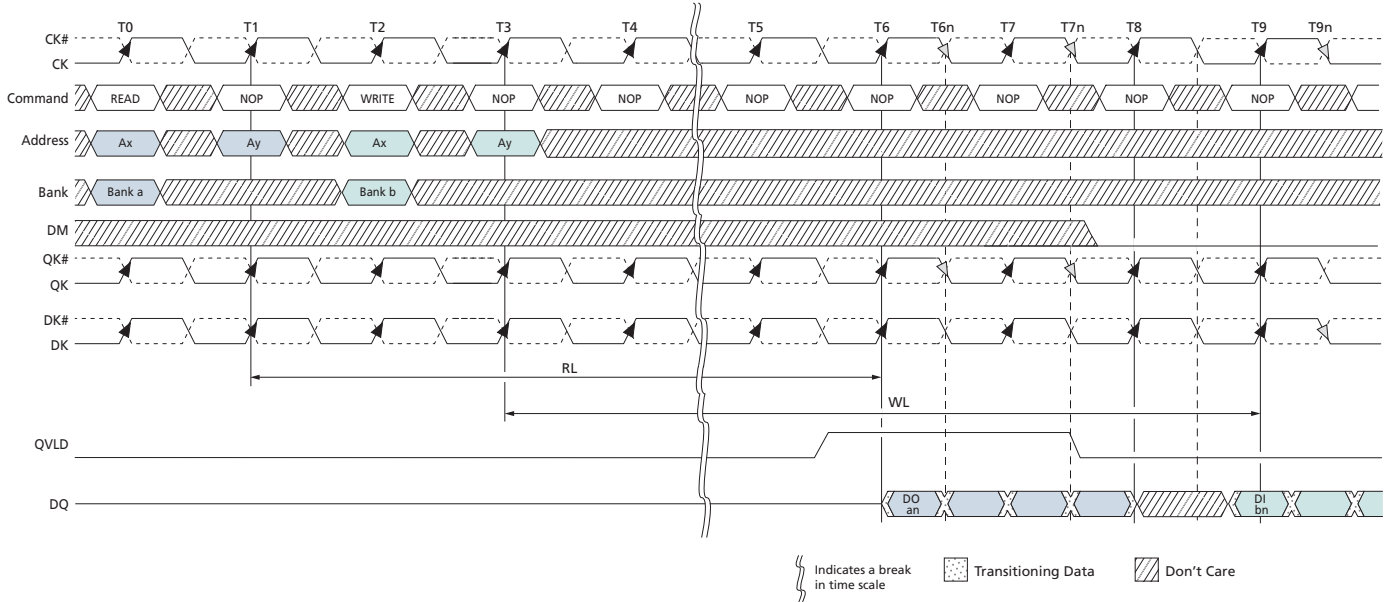

Note: 1. DO a = data-out for bank a; DI b = data-in for bank b.



Mirror Function

The mirror function ball (MF) is a DC input used to create mirrored ballouts for simple dual-loaded clamshell mounting. If the MF ball is tied LOW, the address and command balls are in their true layout. If the MF ball is tied HIGH, the address and command balls are mirrored around the central y-axis (column 7). The following table shows the ball assignments when the MF ball is tied HIGH for a x18 device. Compare that table to Table 1 (page 12) to see how the address and command balls are mirrored. The same balls are mirrored on the x36 device.

Table 42: 32 Meg x 18 Ball Assignments with MF Ball Tied HIGH

| | 1 | 2 | 3 | 4 | 5 | 6 | 7 | 8 | 9 | 10 | 11 | 12 | 13 |
|----------|------------------|------------------|------------------|------------------|------------------|------------------|------------------|------------------|------------------|------------------|------------------|------------------|------------------|
| A | | V _{SS} | V _{DD} | NF | V _{DDQ} | NF | V _{REF} | DQ7 | V _{DDQ} | DQ8 | V _{DD} | V _{SS} | RESET# |
| B | V _{EXT} | V _{SS} | NF | V _{SSQ} | NF | V _{DDQ} | DM0 | V _{DDQ} | DQ5 | V _{SSQ} | DQ6 | V _{SS} | V _{EXT} |
| C | V _{DD} | NF | V _{DDQ} | NF | V _{SSQ} | NF | DK0# | DQ2 | V _{SSQ} | DQ3 | V _{DDQ} | DQ4 | V _{DD} |
| D | A13 | V _{SSQ} | NF | V _{DDQ} | NF | V _{SSQ} | DK0 | V _{SSQ} | QK0 | V _{DDQ} | DQ0 | V _{SSQ} | A11 |
| E | V _{SS} | CS# | V _{SSQ} | NF | V _{DDQ} | NF | MF | QK0# | V _{DDQ} | DQ1 | V _{SSQ} | A0 | V _{SS} |
| F | A9 | A5 | V _{DD} | A4 | A3 | REF# | ZQ | WE# | A1 | A2 | V _{DD} | NC ¹ | A7 |
| G | V _{SS} | A18 | A8 | V _{SS} | BA0 | V _{SS} | CK# | V _{SS} | BA1 | V _{SS} | A6 | A15 | V _{SS} |
| H | A10 | V _{DD} | A12 | A17 | V _{DD} | BA2 | CK | BA3 | V _{DD} | A16 | A14 | V _{DD} | A19 |
| J | V _{DDQ} | NF | V _{SSQ} | NF | V _{DDQ} | NF | V _{SS} | QK1# | V _{DDQ} | DQ9 | V _{SSQ} | QVLD | V _{DDQ} |
| K | NF | V _{SSQ} | NF | V _{DDQ} | NF | V _{SSQ} | DK1 | V _{SSQ} | QK1 | V _{DDQ} | DQ10 | V _{SSQ} | DQ11 |
| L | V _{DD} | NF | V _{DDQ} | NF | V _{SSQ} | NF | DK1# | DQ12 | V _{SSQ} | DQ13 | V _{DDQ} | DQ14 | V _{DD} |
| M | V _{EXT} | V _{SS} | NF | V _{SSQ} | NF | V _{DDQ} | DM1 | V _{DDQ} | DQ15 | V _{SSQ} | DQ16 | V _{SS} | V _{EXT} |
| N | V _{SS} | TCK | V _{DD} | TDO | V _{DDQ} | NF | V _{REF} | DQ17 | V _{DDQ} | TDI | V _{DD} | TMS | V _{SS} |

RESET Operation

The RESET signal (RESET#) is an asynchronous signal that triggers any time it drops LOW. There are no restrictions for when it can go LOW. After RESET# goes LOW, it must remain LOW for 100ns. During this time, the outputs are disabled, ODT (R_{TT}) turns off (High-Z), and the DRAM resets itself. Prior to RESET# going HIGH, at least 100 stable CK cycles with NOP commands must be given to the RLD RAM. After RESET# goes HIGH, the DRAM must be reinitialized as though a normal power-up was executed. All refresh counters on the DRAM are reset, and data stored in the DRAM is assumed unknown after RESET# has gone LOW.



IEEE 1149.1 Serial Boundary Scan (JTAG)

The RLDRAM 3 device incorporates a serial boundary-scan test access port (TAP) for the purpose of testing the connectivity of the device after it has been mounted on a printed circuit board (PCB). As the complexity of PCB high-density surface mounting techniques increases, the boundary-scan architecture is a valuable resource for interconnectivity debug. This port operates in accordance with IEEE Standard 1149.1-2001 (JTAG) with the exception of the ZQ pin. To ensure proper boundary-scan testing of the ZQ pin, MR1[7] needs to be set to 0 until the JTAG testing of the pin is complete. Note that upon power up, the default state of the MRS bit M1[7] is low.

The JTAG test access port utilizes the TAP controller on the device, from which the instruction register, boundary-scan register, bypass register, and ID register can be selected. Each of these functions of the TAP controller is described in detail below.

Disabling the JTAG Feature

It is possible to operate an RLDRAM 3 device without using the JTAG feature. To disable the TAP controller, TCK must be tied LOW (V_{SS}) to prevent clocking of the device. TDI and TMS are internally pulled up and may be unconnected. They may alternately be connected to V_{DDQ} through a pull-up resistor. TDO should be left unconnected. Upon power-up, the device will come up in a reset state, which will not interfere with the operation of the device.

Test Access Port (TAP)

Test Clock (TCK)

The test clock is used only with the TAP controller. All inputs are captured on the rising edge of TCK. All outputs are driven from the falling edge of TCK.

Test Mode Select (TMS)

The TMS input is used to give commands to the TAP controller and is sampled on the rising edge of TCK.

All the states in Figure 68 (page 105) are entered through the serial input of the TMS ball. A 0 in the diagram represents a LOW on the TMS ball during the rising edge of TCK, while a 1 represents a HIGH on TMS.

Test Data-In (TDI)

The TDI ball is used to serially input test instructions and data into the registers and can be connected to the input of any of the registers. The register between TDI and TDO is chosen by the instruction that is loaded into the TAP instruction register. For information on loading the instruction register, see Figure 68 (page 105). TDI is connected to the most significant bit (MSB) of any register (see Figure 69 (page 105)).

Test Data-Out (TDO)

The TDO output ball is used to serially clock test instructions and data out from the registers. The TDO output driver is only active during the Shift-IR and Shift-DR TAP controller states. In all other states, the TDO ball is in a High-Z state. The output changes on the falling edge of TCK. TDO is connected to the least significant bit (LSB) of any register (see Figure 69 (page 105)).



TAP Controller

The TAP controller is a finite state machine that uses the state of the TMS ball at the rising edge of TCK to navigate through its various modes of operation (see Figure 68 (page 105)). Each state is described in detail below.

Test-Logic-Reset

The test-logic-reset controller state is entered when TMS is held HIGH for at least five consecutive rising edges of TCK. As long as TMS remains HIGH, the TAP controller will remain in the test-logic-reset state. The test logic is inactive during this state.

Run-Test/Idle

The run-test/idle is a controller state in between scan operations. This state can be maintained by holding TMS LOW. From there, either the data register scan, or subsequently, the instruction register scan, can be selected.

Select-DR-Scan

Select-DR-scan is a temporary controller state. All test data registers retain their previous state while here.

Capture-DR

The capture-DR state is where the data is parallel-loaded into the test data registers. If the boundary-scan register is the currently selected register, then the data currently on the balls is latched into the test data registers.

Shift-DR

Data is shifted serially through the data register while in this state. As new data is input through the TDI ball, data is shifted out of the TDO ball.

Exit1-DR, Pause-DR, and Exit2-DR

The purpose of exit1-DR is used to provide a path to return back to the run-test/idle state (through the update-DR state). The pause-DR state is entered when the shifting of data through the test registers needs to be suspended. When shifting is to reconvene, the controller enters the exit2-DR state and then can re-enter the shift-DR state.

Update-DR

When the EXTEST instruction is selected, there are latched parallel outputs of the boundary-scan shift register that only change state during the update-DR controller state.

Instruction Register States

The instruction register states of the TAP controller are similar to the data register states. The desired instruction is serially shifted into the instruction register during the shift-IR state and is loaded during the update-IR state.

Figure 68: TAP Controller State Diagram

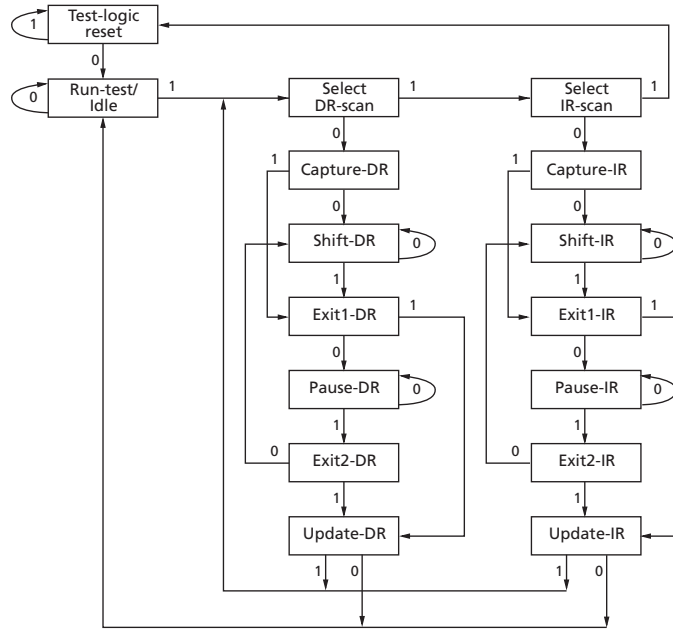
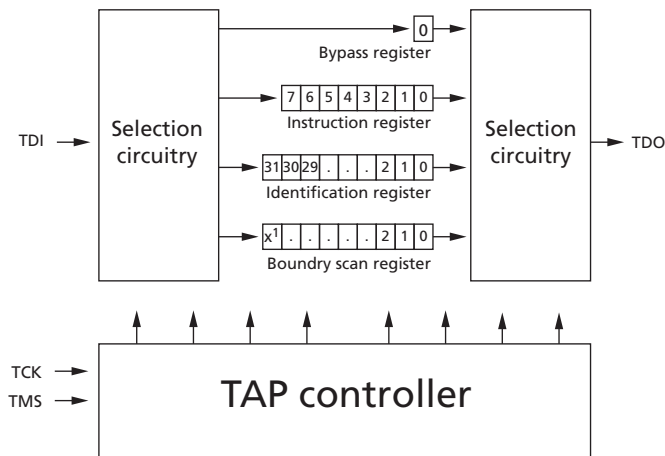

Figure 69: TAP Controller Functional Block Diagram



Note: 1. x = 121 for all configurations.



Performing a TAP RESET

A reset is performed by forcing TMS HIGH (V_{DDQ}) for five rising edges of t_{CK} . This RESET does not affect the operation of the device and may be performed while the device is operating.

At power-up, the TAP is reset internally to ensure that TDO comes up in a High-Z state. If JTAG inputs cannot be guaranteed to be stable during power-up it is recommended that TMS be held HIGH for at least 5 consecutive TCK cycles prior to boundary scan testing.

TAP Registers

Registers are connected between the TDI and TDO balls and allow data to be scanned into and out of the RLD RAM 3 device test circuitry. Only one register can be selected at a time through the instruction register. Data is serially loaded into the TDI ball on the rising edge of TCK. Data is output on the TDO ball on the falling edge of TCK.

Instruction Register

Eight-bit instructions can be serially loaded into the instruction register. This register is loaded during the update-IR state of the TAP controller. Upon power-up, the instruction register is loaded with the IDCODE instruction. It is also loaded with the IDCODE instruction if the controller is placed in a reset state as described in the previous section.

When the TAP controller is in the capture-IR state, the two LSBs are loaded with a binary 01 pattern to allow for fault isolation of the board-level serial test data path.

Bypass Register

To save time when serially shifting data through registers, it is sometimes advantageous to skip certain chips. The bypass register is a single-bit register that can be placed between the TDI and TDO balls. This enables data to be shifted through the device with minimal delay. The bypass register is set LOW (V_{SS}) when the BYPASS instruction is executed.

Boundary-Scan Register

The boundary-scan register is connected to all the input and bidirectional balls on the device. Several balls are also included in the scan register to reserved balls. The device has a 121-bit register.

The boundary-scan register is loaded with the contents of the RAM I/O ring when the TAP controller is in the capture-DR state and is then placed between the TDI and TDO balls when the controller is moved to the shift-DR state.

The order in which the bits are connected is shown in Table 49 (page 111). Each bit corresponds to one of the balls on the RLD RAM package. The MSB of the register is connected to TDI, and the LSB is connected to TDO.

Identification (ID) Register

The ID register is loaded with a vendor-specific, 32-bit code during the capture-DR state when the IDCODE command is loaded in the instruction register. The IDCODE is hardwired into the RLD RAM 3 and can be shifted out when the TAP controller is in the shift-DR state. The ID register has a vendor code and other information described in Table 46 (page 110).



TAP Instruction Set

Overview

There are 2^8 different instructions possible with the 8-bit instruction register. All combinations used are listed in Table 48 (page 111). These six instructions are described in detail below. The remaining instructions are reserved and should not be used.

The TAP controller used in this RLD RAM 3 device is fully compliant to the IEEE 1149.1 convention.

Instructions are loaded into the TAP controller during the shift-IR state when the instruction register is placed between TDI and TDO. During this state, instructions are shifted through the instruction register through the TDI and TDO balls. To execute the instruction after it is shifted in, the TAP controller needs to be moved into the update-IR state.

EXTEST

The EXTEST instruction enables circuitry external to the component package to be tested. Boundary-scan register cells at output balls are used to apply a test vector, while those at input balls capture test results. Typically, the first test vector to be applied using the EXTEST instruction will be shifted into the boundary-scan register using the PRELOAD instruction. Thus, during the update-IR state of EXTEST, the output driver is turned on, and the PRELOAD data is driven onto the output balls.

IDCODE

The IDCODE instruction causes a vendor-specific, 32-bit code to be loaded into the instruction register. It also places the instruction register between the TDI and TDO balls and enables the IDCODE to be shifted out of the device when the TAP controller enters the shift-DR state. The IDCODE instruction is loaded into the instruction register upon power-up or whenever the TAP controller is given a test logic reset state.

High-Z

The High-Z instruction causes the bypass register to be connected between the TDI and TDO. This places all RLD RAM outputs into a High-Z state.

CLAMP

When the CLAMP instruction is loaded into the instruction register, the data driven by the output balls are determined from the values held in the boundary-scan register.

SAMPLE/PRELOAD

When the SAMPLE/PRELOAD instruction is loaded into the instruction register and the TAP controller is in the capture-DR state, a snapshot can be taken of the states of the component's input and output signals without interfering with the normal operation of the assembled board. The snapshot is taken on the rising edge of TCK and is captured in the boundary-scan register. The data can then be viewed by shifting through the component's TDO output.

The user must be aware that the TAP controller clock can only operate at a frequency up to 50 MHz, while the RLD RAM 3 clock operates significantly faster. Because there is a large difference between the clock frequencies, it is possible that during the capture-DR state, an input or output will undergo a transition. The TAP may then try to capture a signal while in transition (metastable state). This will not harm the device, but there is

no guarantee as to the value that will be captured. Repeatable results may not be possible.

To ensure that the boundary-scan register will capture the correct value of a signal, the RLD RAM signal must be stabilized long enough to meet the TAP controller's capture setup plus hold time (t_{CS} plus t_{CH}). The RLD RAM clock input might not be captured correctly if there is no way in a design to stop (or slow) the clock during a SAMPLE/PRELOAD instruction. If this is an issue, it is still possible to capture all other signals and simply ignore the value of the CK and CK# captured in the boundary-scan register.

After the data is captured, it is possible to shift out the data by putting the TAP into the shift-DR state. This places the boundary-scan register between the TDI and TDO balls.

BYPASS

When the BYPASS instruction is loaded in the instruction register and the TAP is placed in a shift-DR state, the bypass register is placed between TDI and TDO. The advantage of the BYPASS instruction is that it shortens the boundary-scan path when multiple devices are connected together on a board.

Reserved for Future Use

The remaining instructions are not implemented but are reserved for future use. Do not use these instructions.

Figure 70: JTAG Operation - Loading Instruction Code and Shifting Out Data

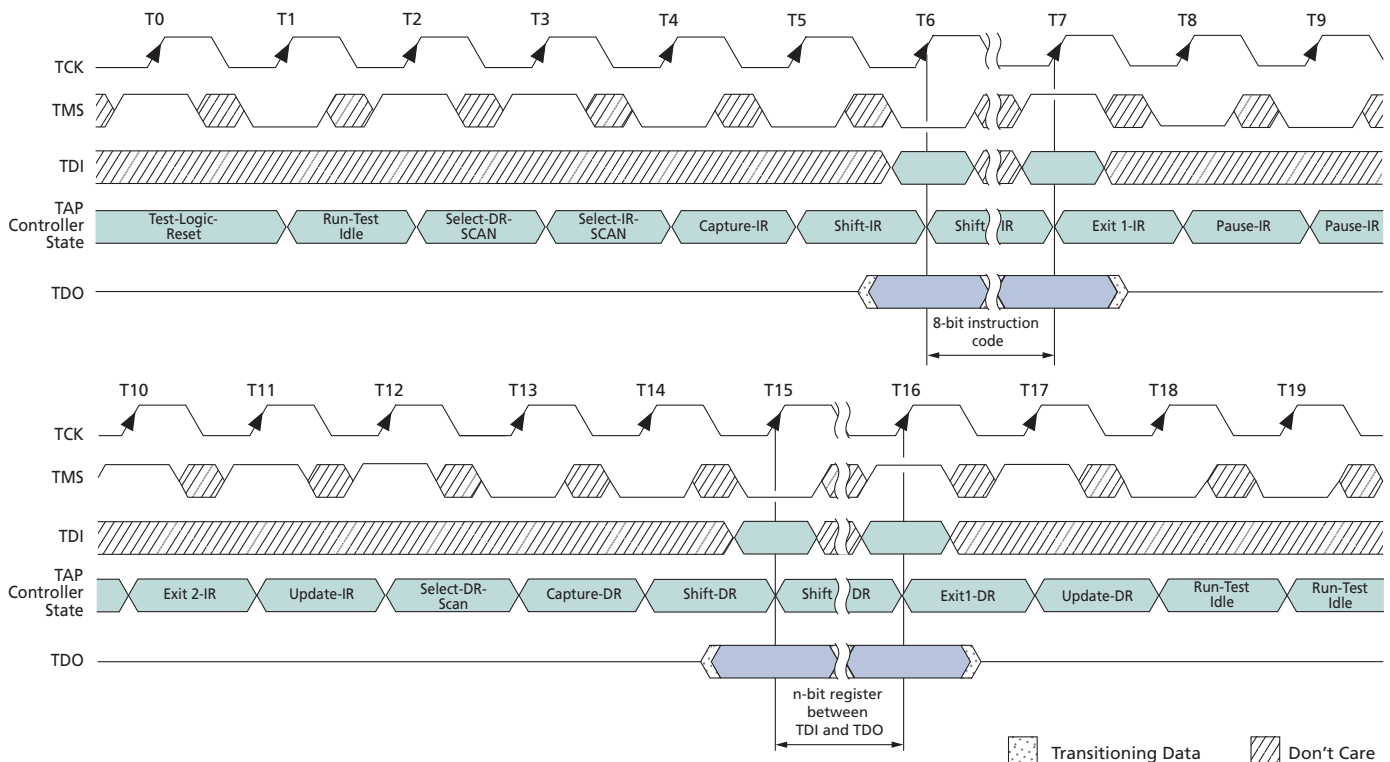

Figure 71: TAP Timing

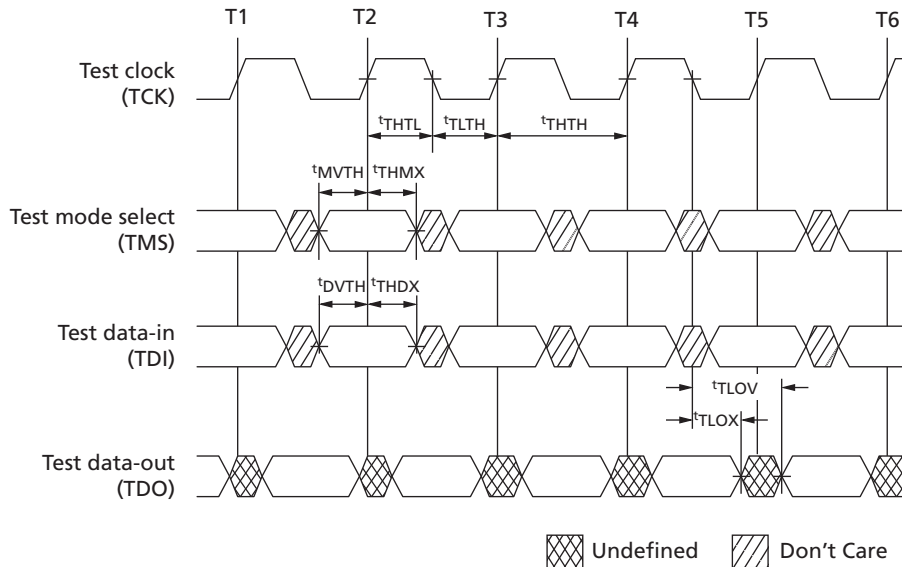

Table 43: TAP Input AC Logic Levels

0°C ≤ T_C ≤ +95°C; +1.28V ≤ V_{DD} ≤ +1.42V, unless otherwise noted

| Description | Symbol | Min | Max | Units |
|------------------------------|-----------------|--------------------------|--------------------------|-------|
| Input HIGH (logic 1) voltage | V _{IH} | V _{REF} + 0.225 | - | V |
| Input LOW (logic 0) voltage | V _{IL} | - | V _{REF} - 0.225 | V |

Note: 1. All voltages referenced to V_{SS} (GND).

Table 44: TAP AC Electrical Characteristics

0°C ≤ T_C ≤ +95°C; +1.28V ≤ V_{DD} ≤ +1.42V

| Description | Symbol | Min | Max | Units |
|-------------------------|-------------------|-----|-----|-------|
| Clock | | | | |
| Clock cycle time | t _{THTH} | 20 | | ns |
| Clock frequency | f _{TF} | | 50 | MHz |
| Clock HIGH time | t _{THTL} | 10 | | ns |
| Clock LOW time | t _{TLTH} | 10 | | ns |
| TDI/TDO times | | | | |
| TCK LOW to TDO unknown | t _{TLOX} | 0 | | ns |
| TCK LOW to TDO valid | t _{TLOV} | | 10 | ns |
| TDI valid to TCK HIGH | t _{DVTH} | 5 | | ns |
| TCK HIGH to TDI invalid | t _{DTHX} | 5 | | ns |
| Setup times | | | | |
| TMS setup | t _{MVTH} | 5 | | ns |



Table 44: TAP AC Electrical Characteristics (Continued)

$0^{\circ}\text{C} \leq T_C \leq +95^{\circ}\text{C}$; $+1.28\text{V} \leq V_{DD} \leq +1.42\text{V}$

| Description | Symbol | Min | Max | Units |
|---------------|-------------------|-----|-----|-------|
| Capture setup | t^{CS} | 5 | | ns |
| Hold times | | | | |
| TMS hold | t^{THMX} | 5 | | ns |
| Capture hold | t^{CH} | 5 | | ns |

Note: 1. t^{CS} and t^{CH} refer to the setup and hold time requirements of latching data from the boundary-scan register.

Table 45: TAP DC Electrical Characteristics and Operating Conditions

$0^{\circ}\text{C} \leq T_C \leq +95^{\circ}\text{C}$; $+1.28\text{V} \leq V_{DD} \leq +1.42\text{V}$, unless otherwise noted

| Description | Condition | Symbol | Min | Max | Units | Notes |
|------------------------------|---|-----------|------------------|------------------|---------------|-------|
| Input HIGH (logic 1) voltage | | V_{IH} | $V_{REF} + 0.15$ | V_{DDQ} | V | 1, 2 |
| Input LOW (logic 0) voltage | | V_{IL} | V_{SSQ} | $V_{REF} - 0.15$ | V | 1, 2 |
| Input leakage current | $0\text{V} \leq V_{IN} \leq V_{DD}$ | I_{LI} | -5.0 | 5.0 | μA | |
| Output leakage current | Output disabled, $0\text{V} \leq V_{IN} \leq V_{DDQ}$ | I_{LO} | -5.0 | 5.0 | μA | |
| Output low voltage | $I_{OLC} = 100\mu\text{A}$ | V_{OL1} | | 0.2 | V | 1 |
| Output low voltage | $I_{OLT} = 2\text{mA}$ | V_{OL2} | | 0.4 | V | 1 |
| Output high voltage | $ I_{OHC} = 100\mu\text{A}$ | V_{OH1} | $V_{DDQ} - 0.2$ | | V | 1 |
| OUTPUT HIGH VOLTAGE | $ I_{OHT} = 2\text{mA}$ | V_{OH2} | $V_{DDQ} - 0.4$ | | V | 1 |

Notes: 1. All voltages referenced to V_{SS} (GND).
2. See AC Overshoot/Undershoot Specifications section for overshoot and undershoot limits.

Table 46: Identification Register Definitions

| Instruction Field | All Devices | Description |
|------------------------------------|------------------|---|
| Revision number (31:28) | abcd | ab = 00 for Die Revision A cd = 00 for x18, 01 for x36 |
| Device ID (27:12) | 00jkidef10100111 | def = 000 for 576Mb, 001 for 1Gb Double Die Package, 010 for 1Gb Monolithic i = 0 for common I/O jk = 10 for RLDRAM 3 |
| ISSI JEDEC ID code (11:1) | 00011010101 | Enables unique identification of RLDRAM vendor |
| ID register presence indicator (0) | 1 | Indicates the presence of an ID register |



Table 47: Scan Register Sizes

| Register Name | Bit Size |
|---------------|----------|
| Instruction | 8 |
| Bypass | 1 |
| ID | 32 |
| Boundary scan | 121 |

Table 48: Instruction Codes

| Instruction | Code | Description |
|----------------|-----------|---|
| Extest | 0000 0000 | Captures I/O ring contents; Places the boundary-scan register between TDI and TDO; This operation does not affect RLDRAM 3 operations. |
| ID code | 0010 0001 | Loads the ID register with the vendor ID code and places the register between TDI and TDO; This operation does not affect RLDRAM 3 operations. |
| Sample/preload | 0000 0101 | Captures I/O ring contents; Places the boundary-scan register between TDI and TDO. |
| Clamp | 0000 0111 | Selects the bypass register to be connected between TDI and TDO; Data driven by output balls are determined from values held in the boundary-scan register. |
| High-Z | 0000 0011 | Selects the bypass register to be connected between TDI and TDO; All outputs are forced into High-Z. |
| Bypass | 1111 1111 | Places the bypass register between TDI and TDO; This operation does not affect RLDRAM operations. |

Table 49: Boundary Scan (Exit)

| Bit# | Ball | Bit# | Ball | Bit# | Ball |
|------|------|------|------|------|------|
| 1 | N8 | 42 | L7 | 83 | M3 |
| 2 | N8 | 43 | K7 | 84 | M3 |
| 3 | M11 | 44 | H1 | 85 | M5 |
| 4 | M11 | 45 | H4 | 86 | M5 |
| 5 | M9 | 46 | G2 | 87 | L2 |
| 6 | M9 | 47 | G3 | 88 | L2 |
| 7 | L12 | 48 | F1 | 89 | L4 |
| 8 | L12 | 49 | F5 | 90 | L4 |
| 9 | L10 | 50 | F4 | 91 | L6 |
| 10 | L10 | 51 | F2 | 92 | L6 |
| 11 | L8 | 52 | D1 | 93 | K1 |
| 12 | L8 | 53 | F7 | 94 | K1 |
| 13 | K13 | 54 | D7 | 95 | K3 |
| 14 | K13 | 55 | C7 | 96 | K3 |
| 15 | K11 | 56 | A13 | 97 | J4 |
| 16 | K11 | 57 | B7 | 98 | J4 |



Table 49: Boundary Scan (Exit) (Continued)

| Bit# | Ball | Bit# | Ball | Bit# | Ball |
|------|------|------|------|------|------|
| 17 | J10 | 58 | E7 | 99 | J6 |
| 18 | J10 | 59 | D13 | 100 | K5 |
| 19 | J8 | 60 | F12 | 101 | J2 |
| 20 | K9 | 61 | F10 | 102 | A4 |
| 21 | J12 | 62 | F9 | 103 | A4 |
| 22 | A10 | 63 | E2 | 104 | A6 |
| 23 | A10 | 64 | E12 | 105 | A6 |
| 24 | A8 | 65 | F6 | 106 | B3 |
| 25 | A8 | 66 | F8 | 107 | B3 |
| 26 | B11 | 67 | G7 | 108 | B5 |
| 27 | B11 | 68 | H7 | 109 | B5 |
| 28 | B9 | 69 | G5 | 110 | C2 |
| 29 | B9 | 70 | G9 | 111 | C2 |
| 30 | C12 | 71 | H6 | 112 | C4 |
| 31 | C12 | 72 | H8 | 113 | C4 |
| 32 | C10 | 73 | F13 | 114 | C6 |
| 33 | C10 | 74 | G11 | 115 | C6 |
| 34 | C8 | 75 | G12 | 116 | E4 |
| 35 | C8 | 76 | H10 | 117 | E4 |
| 36 | E10 | 77 | H3 | 118 | D3 |
| 37 | E10 | 78 | H11 | 119 | D3 |
| 38 | D11 | 79 | H13 | 120 | E6 |
| 39 | D11 | 80 | M7 | 121 | D5 |
| 40 | E8 | 81 | N6 | - | - |
| 41 | D9 | 82 | N6 | - | - |



Table 50: Ordering Information
Commercial Range: T_C = 0° to +95°C

| Frequency | Speed (tCK) | tRC(min) | Order Part No. | Organization | Package |
|-----------|-------------|----------|--------------------|--------------|---------------------|
| 1066 MHz | 0.93ns | 8ns | IS49RL18320-093EBL | 32M x 18 | 168 FBGA, Lead-free |
| | | | IS49RL36160-093EBL | 16M x 36 | 168 FBGA, Lead-free |
| | | 10ns | IS49RL18320-093BL | 32M x 18 | 168 FBGA, Lead-free |
| | | | IS49RL36160-093BL | 16M x 36 | 168 FBGA, Lead-free |
| 933 MHz | 1.07ns | 8ns | IS49RL18320-107EBL | 32M x 18 | 168 FBGA, Lead-free |
| | | | IS49RL36160-107EBL | 16M x 36 | 168 FBGA, Lead-free |
| | | 10ns | IS49RL18320-107BL | 32M x 18 | 168 FBGA, Lead-free |
| | | | IS49RL36160-107BL | 16M x 36 | 168 FBGA, Lead-free |
| 800 MHz | 1.25ns | 8ns | IS49RL18320-125FBL | 32M x 18 | 168 FBGA, Lead-free |
| | | | IS49RL36160-125FBL | 16M x 36 | 168 FBGA, Lead-free |
| | | 10ns | IS49RL18320-125EBL | 32M x 18 | 168 FBGA, Lead-free |
| | | | IS49RL36160-125EBL | 16M x 36 | 168 FBGA, Lead-free |
| | | 12ns | IS49RL18320-125BL | 32M x 18 | 168 FBGA, Lead-free |
| | | | IS49RL36160-125BL | 16M x 36 | 168 FBGA, Lead-free |

Industrial Range: T_C = -40° to +95°C

| Frequency | Speed (tCK) | tRC(min) | Order Part No. | Organization | Package |
|-----------|-------------|----------|---------------------|--------------|---------------------|
| 1066 MHz | 0.93ns | 8ns | IS49RL18320-093EBLI | 32M x 18 | 168 FBGA, Lead-free |
| | | | IS49RL36160-093EBLI | 16M x 36 | 168 FBGA, Lead-free |
| | | 10ns | IS49RL18320-093BLI | 32M x 18 | 168 FBGA, Lead-free |
| | | | IS49RL36160-093BLI | 16M x 36 | 168 FBGA, Lead-free |
| 933 MHz | 1.07ns | 8ns | IS49RL18320-107EBLI | 32M x 18 | 168 FBGA, Lead-free |
| | | | IS49RL36160-107EBLI | 16M x 36 | 168 FBGA, Lead-free |
| | | 10ns | IS49RL18320-107BLI | 32M x 18 | 168 FBGA, Lead-free |
| | | | IS49RL36160-107BLI | 16M x 36 | 168 FBGA, Lead-free |
| 800 MHz | 1.25ns | 8ns | IS49RL18320-125FBLI | 32M x 18 | 168 FBGA, Lead-free |
| | | | IS49RL36160-125FBLI | 16M x 36 | 168 FBGA, Lead-free |
| | | 10ns | IS49RL18320-125EBLI | 32M x 18 | 168 FBGA, Lead-free |
| | | | IS49RL36160-125EBLI | 16M x 36 | 168 FBGA, Lead-free |
| | | 12ns | IS49RL18320-125BLI | 32M x 18 | 168 FBGA, Lead-free |
| | | | IS49RL36160-125BLI | 16M x 36 | 168 FBGA, Lead-free |



Revision History

Rev. C, Production – 12/12

- Changed the units from nS to CK for tWTR specification
- Corrected values from 0.935 to 0.9375 in the speed bin table
- Added reference to -125F on front page, part number guide, speed bin table, and tRC_MRS table
- Added a -125F column into the IDD table
- Updated the I_{mbref4} IDD values for most fields. This increase is necessary because a mistake in the char test used to set these limits caused the values to be incorrect
- Corrected typo in the tIS/tIH derating table. (tIH - 0.4 CMD/ADDR slew rate, CK/CK# 4.0 V/ns)
- Changed definition of NOP command to specify the states of WE# & REF#
- Added note on the leaded (PA) package to "Consult factory"
- Updated READ-to-WRITE timing diagram from BL = 4 to BL = 2. The WRITE-to-READ timing diagram is BL = 2 (I did not want customers to think that a NOP was required when transitioning from a READ to a WRITE)
- Changed wording in Note 3 of ZQ calibration description
- Added note to general description, which explains using a X36 devices with only 2 QK/QK# sets instead of all 4.
- Modified ball out to reflect the ballout required to support the X18 DDP and the 2Gb monolithic devices
- Added note to Iref that states: "all other balls not under test = 0V"
- Added updates to -125F speed bin table and tRC_MRS table to meet customer request to support CL=12, tRC_MRS = 6 for tCK=1.334ns

Rev. B, Advance – 1/12

- Changed tQKQ_{x,min} to tQKQ_{x,max} in figure 52 read data valid window
- Added Vext information to Note 1 of Input/Output Capacitance table
- Added Table 38 tRC_MRS values
- Updated tIS/tIH(base) values on page 50 to 85,120,170 & 65,100, 120
- Corrected error in High-Z description. replaced "boundry-scan" with "bypass"
- Added verbage in SAMPLE/PRELOAD description, specifying which edge of TCK is used to capture the states of the pins.
- Changed JTAG boundary scan order. Now L7=bit 42, K7=bit 43, J6=bit 99, K5=bit 100
- Updated Figure 70 "JTAG Operation" to match actual operation of the device.
- Changed QK_x, QK_{x#} to DK_x, DK_{x#} in table 33 & 34 Derating values for tDS/tDH.
- Changed Cjtag min from 2.0 to 1.5.
- Corrected typo in X36 functional block diagram. Changed DQ1/DK1# to DK1/DK1#.
- Added RESET# and MF pin Ci Max spec into Input/Output Capacitance table 6.
- Listed QVLD with the QK/QK# signals in Table 6.
- Changed tDS Base value from 15 to -15 in Table 33.
- Corrected errors in VSEH min, VSEL max and VILdiff(AC) max definitions.
- Updated Speed bin table 26 to fill in tCK gaps by adjusting tCKmin values for -107E, RL=5, -125, RL=6,9,14,15.



- Updated table 38 tRC_MRS values to reflect the speed bin table changes
- Changed the Cimax (CMD, ADDR) spec from 2.1 to 2.25
- Changed the Cjtag max from 5.3 to 4.5
- Added X18 & X36 IDD values.
- updated tCKQK AC timing specifications.
- Added in the thermal impedance values

Rev. A, Advance – 6/11

- Initial release



Компания «ЭлектроПласт» предлагает заключение долгосрочных отношений при поставках импортных электронных компонентов на взаимовыгодных условиях!

Наши преимущества:

- Оперативные поставки широкого спектра электронных компонентов отечественного и импортного производства напрямую от производителей и с крупнейших мировых складов;
- Поставка более 17-ти миллионов наименований электронных компонентов;
- Поставка сложных, дефицитных, либо снятых с производства позиций;
- Оперативные сроки поставки под заказ (от 5 рабочих дней);
- Экспресс доставка в любую точку России;
- Техническая поддержка проекта, помощь в подборе аналогов, поставка прототипов;
- Система менеджмента качества сертифицирована по Международному стандарту ISO 9001;
- Лицензия ФСБ на осуществление работ с использованием сведений, составляющих государственную тайну;
- Поставка специализированных компонентов (Xilinx, Altera, Analog Devices, Intersil, Interpoint, Microsemi, Aeroflex, Peregrine, Syfer, Eurofarad, Texas Instrument, Miteq, Cobham, E2V, MA-COM, Hittite, Mini-Circuits, General Dynamics и др.);

Помимо этого, одним из направлений компании «ЭлектроПласт» является направление «Источники питания». Мы предлагаем Вам помощь Конструкторского отдела:

- Подбор оптимального решения, техническое обоснование при выборе компонента;
- Подбор аналогов;
- Консультации по применению компонента;
- Поставка образцов и прототипов;
- Техническая поддержка проекта;
- Защита от снятия компонента с производства.



Как с нами связаться

Телефон: 8 (812) 309 58 32 (многоканальный)

Факс: 8 (812) 320-02-42

Электронная почта: org@eplast1.ru

Адрес: 198099, г. Санкт-Петербург, ул. Калинина, дом 2, корпус 4, литера А.